

IN-90 111
32990
p.260

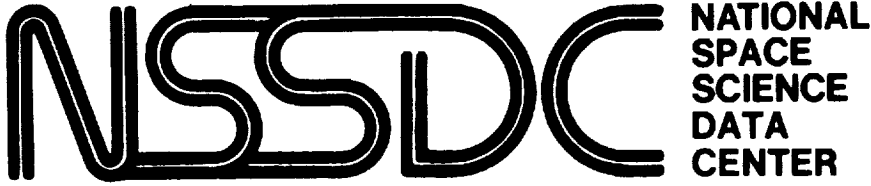

WORLD DATA CENTER A for ROCKETS AND SATELLITES

90-11

1983 TAIL-ERA DATA
SERIES
VOLUME 1

ISEE 3 Plasma

(NASA-TM-105048-Vol-1) THE 1983 TAIL-ERA
SERIES. VOLUME 1: ISEE 3 PLASMA (NASA)
260 p CSCL 03R

N91-31047

Unclas
G3/90 0032990



Goddard Space Flight Center

1
2
3
4
5
6
7
8
9
10
11
12
13
14
15
16
17
18
19
20
21
22
23
24
25
26
27
28
29
30
31
32
33
34
35
36
37
38
39
40
41
42
43
44
45
46
47
48
49
50
51
52
53
54
55
56
57
58
59
60
61
62
63
64
65
66
67
68
69
70
71
72
73
74
75
76
77
78
79
80
81
82
83
84
85
86
87
88
89
90
91
92
93
94
95
96
97
98
99
100

Faint, illegible text covering the majority of the page, appearing as a series of horizontal lines and scattered characters.

1983 TAIL-ERA DATA SERIES

VOLUME 1

ISEE 3 PLASMA

April 1990

Prepared by

D. H. Fairfield

**Lab. for Extraterrestrial Physics, NASA Goddard Space Flight Center
and**

J. L. Phillips

Los Alamos National Laboratory, Los Alamos, New Mexico



Foreword

This is the first in a series of volumes covering the period when the ISEE 3 spacecraft was within and near the earth's magnetic tail. Spacecraft trajectory projected into the equatorial plane is shown in figures 1 and 2 with figure 1 covering the data period December 21 1982-March 30 1983 and figure 2 covering the subsequent period March 30-September 27 1983.

Plots show observations from the ISEE-3 electron analyzer (Principal Investigator originally S. J. Bame, currently J. T. Gosling, LANL). The instrument measured electrons in 15 continuous energy levels between 8.5 and 1140 eV during individual three-second spacecraft spins. Depending on spacecraft mode, the samples occur at 84-second, or sometimes at 12-second intervals (Bame et al., IEEE Trans. Geosci. Electr., GE-16, p 160, 1978; Bame et al., GRL p 912, 1983). Times associated with each data point are the beginning times of the 3 second data collection interval. Moments calculated from the measured distribution function are shown in the figures as density, temperature, velocity, and velocity azimuthal angle. (0° is antisunward flow, $+90^\circ$ is dawnward flow and -90° is duskward flow degrees. Spacecraft ephemeris is shown at the bottom in GSE and GSM coordinates in units of Earth radii, with vertical ticks on the time axis corresponding to the printed positions. Data gaps occur when either plasma or magnetic field (see volume 2) are missing. Thus, in some cases there actually may be plasma data available that are not plotted here.

The principal investigators for the ISEE 3 plasma experiment, S. J. Bame and J. T. Gosling are gratefully acknowledged for allowing this use of their data. Merged data tapes from which these plots were made were prepared by R. D. Zwickl. It is planned to make the tapes available through the National Space Science Data Center. The full set of ISEE 3 electron data are available as NSSDC data set 78-079A-01M. Plots were prepared by K. J. Sofaly of LANL. Questions concerning the plots or requests for electron data should be addressed to J. L. Phillips, MS-D438, LANL, Los Alamos NM 87545; Phone 505-667-3101; Span ESSDP1::102657.

ISEE -3 GEOTAIL PASSES 1 AND 2

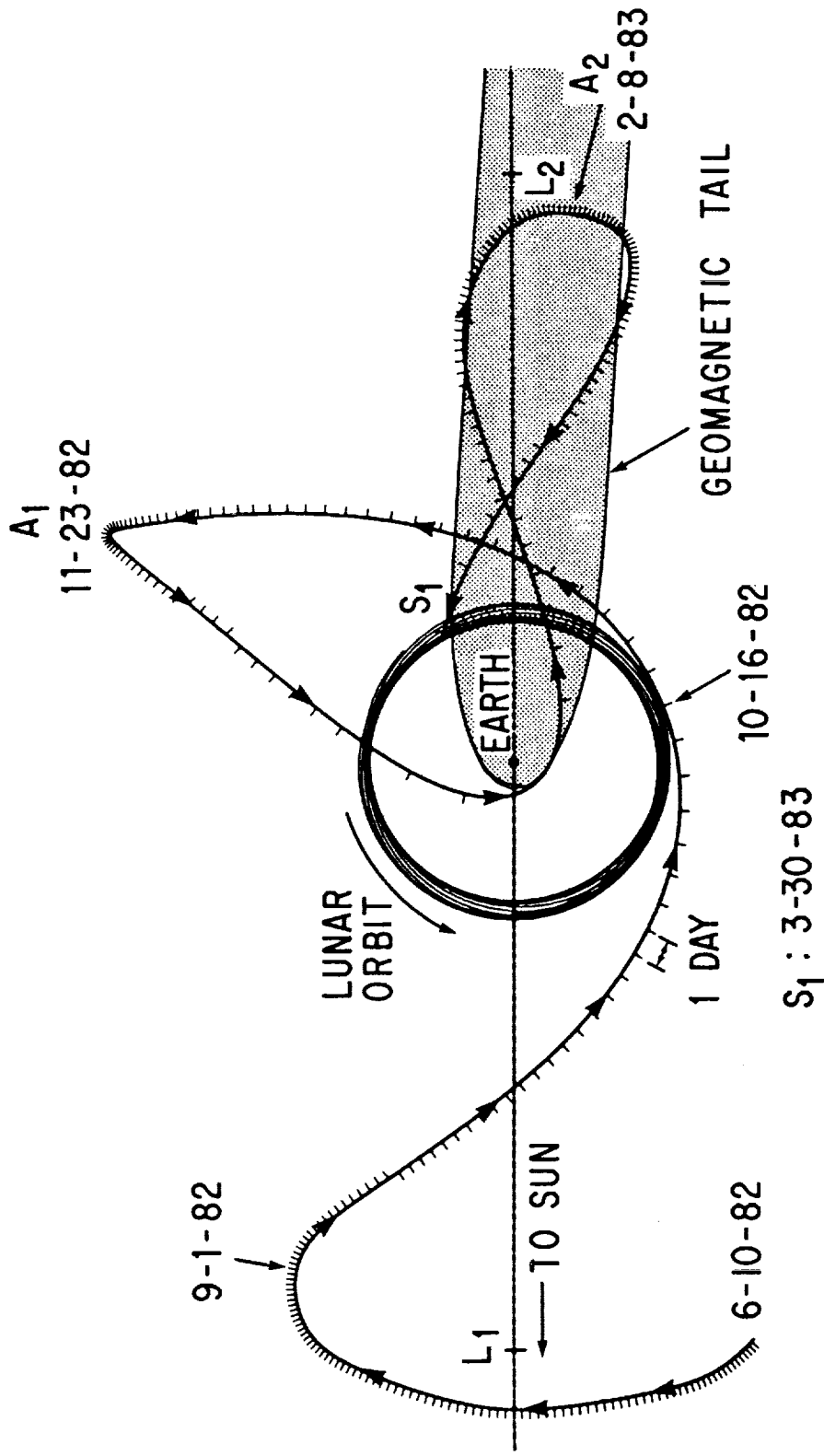

Figure 1

ISEE-3 GEOTAIL PASSES 3 AND 4

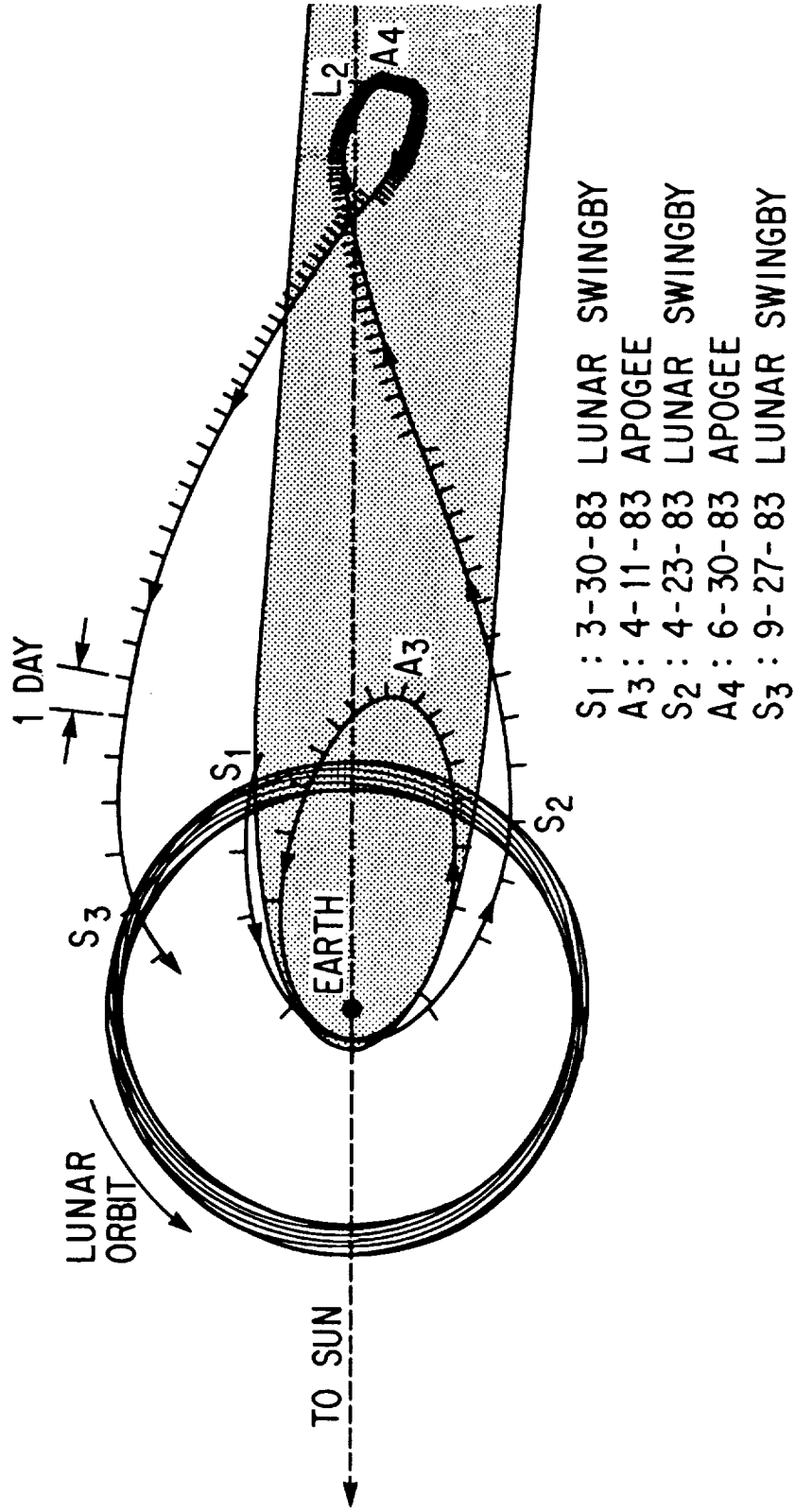
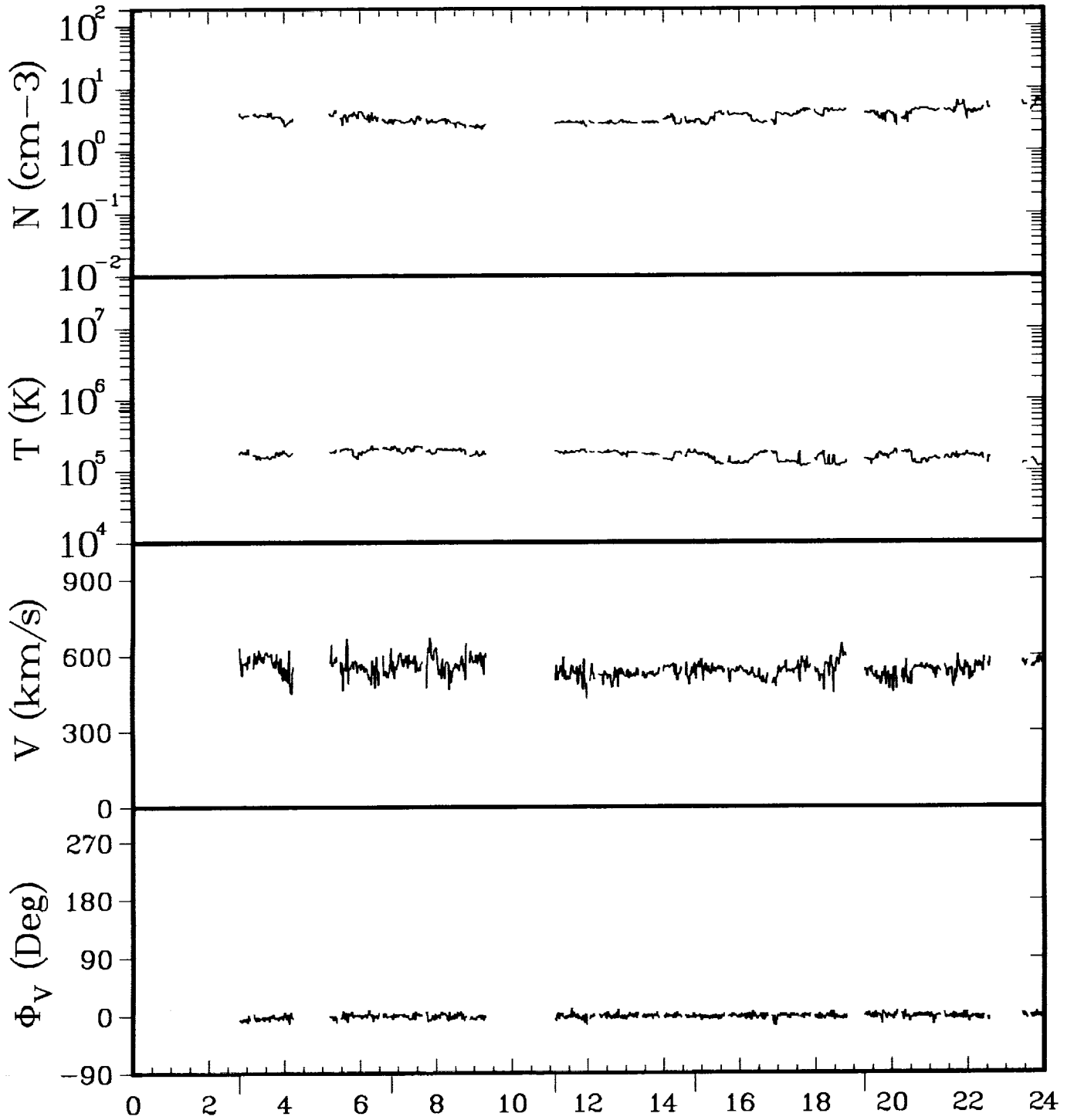
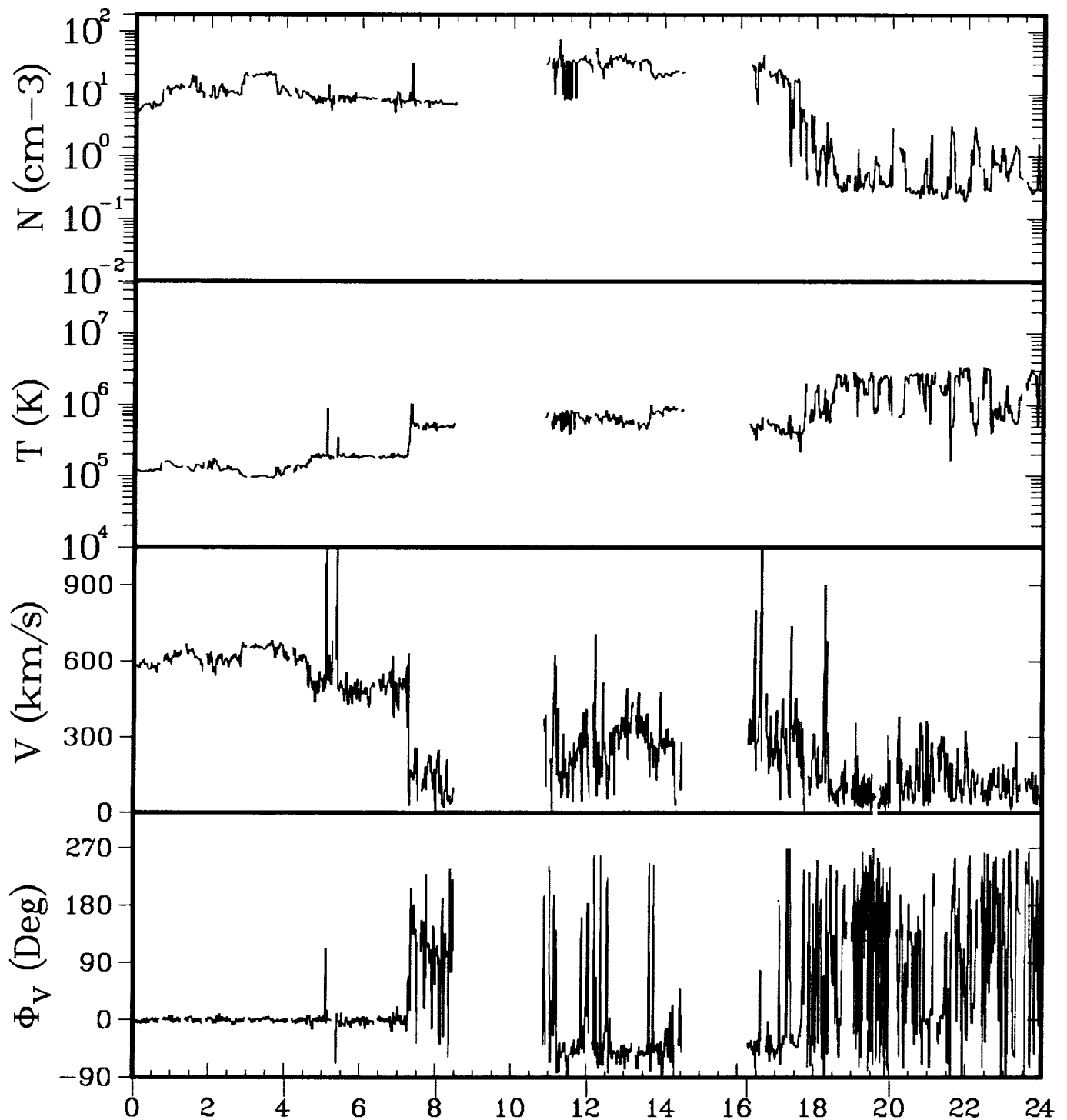

Figure 2



ISEE-3 ELECTRONS 12/21/82

GSEX	8.2	9.7	11.3	12.5	13.8
Y	-33.8	-30.3	-26.1	-22.2	-17.1
Z	-6.8	-6.3	-5.8	-5.3	-4.6
GSMY	-33.0	-30.9	-26.7	-22.7	-16.4
Z	-10.2	-2.0	0.1	-3.1	-6.8



ISEE-3 ELECTRONS 12/22/82

GSEX	14.6	14.5	13.3	10.4	5.5	0.4
Y	-11.1	-5.3	0.8	6.8	11.9	15.0
Z	-3.6	-2.6	-1.4	0.0	1.4	2.6
GSMY	-10.0	-5.2	0.5	6.6	12.0	14.4
Z	-5.9	-2.8	-1.5	-1.4	1.3	5.1

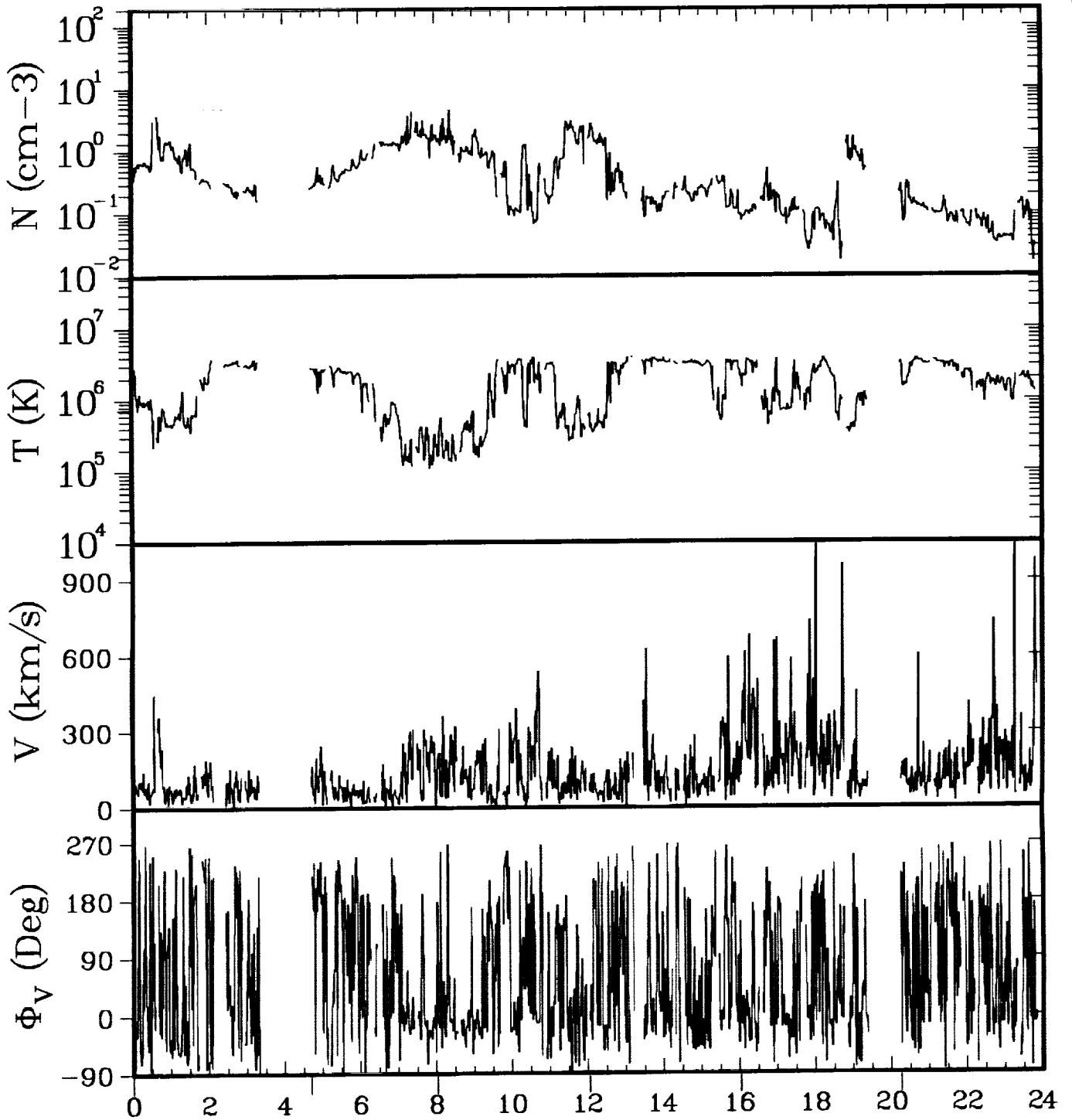

ISEE-3 ELECTRONS 12/23/82

GSEX	-5.0	-11.0	-15.0	-19.6	-23.8	-28.0
Y	17.1	18.4	18.8	19.0	19.0	18.7
Z	3.6	4.5	5.0	5.6	6.0	6.4
GSMY	15.9	18.4	19.4	19.7	19.1	17.2
Z	7.2	4.5	1.6	1.8	5.7	9.8

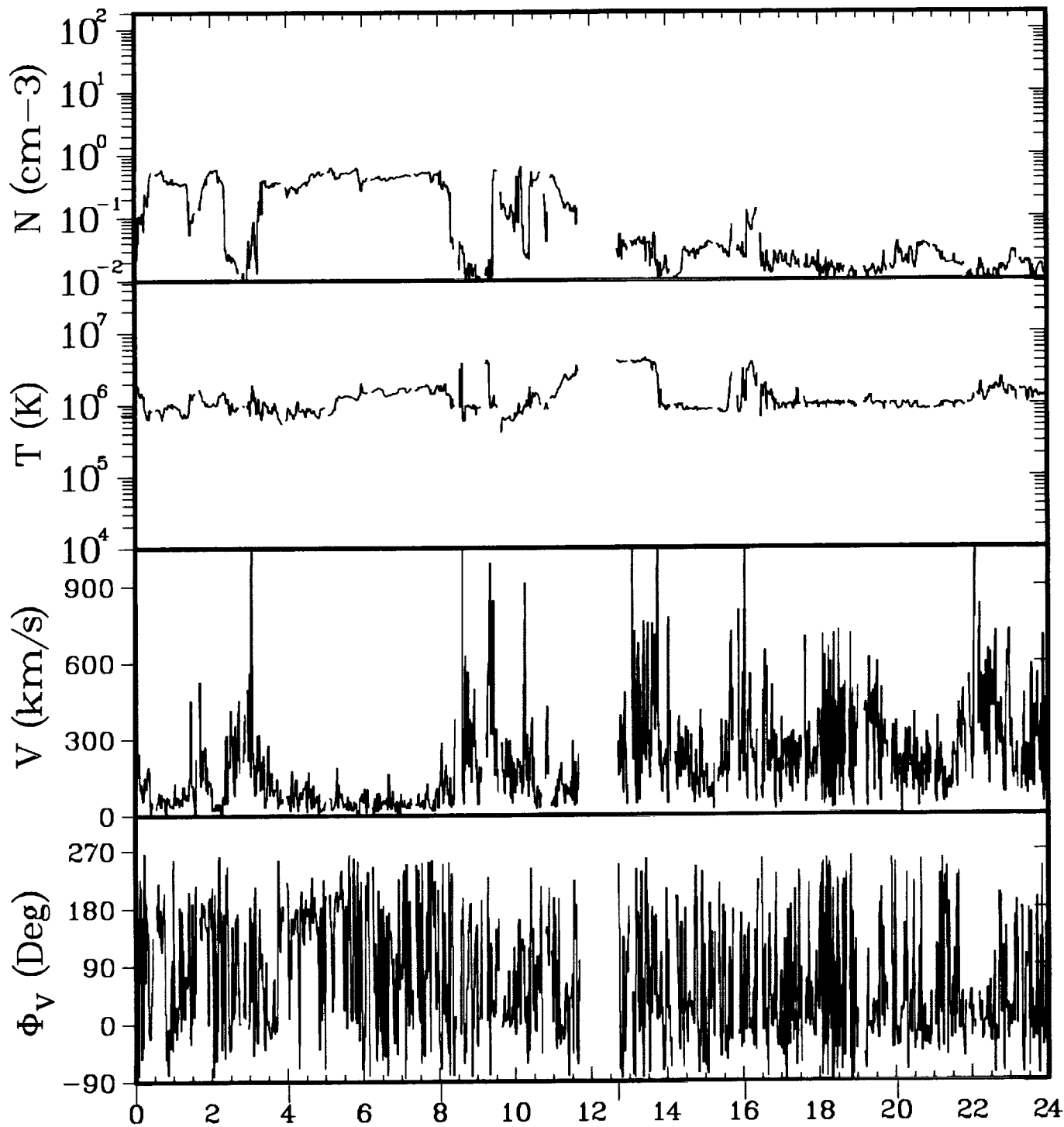

ISEE-3 ELECTRONS 12/24/82

GSEX	-31.5	-35.0	-38.4	-42.2	-44.8	-47.7
Y	18.3	17.9	17.3	16.6	16.1	15.5
Z	6.7	7.0	7.3	7.6	7.8	7.9
GSMY	16.3	17.5	18.3	17.7	16.2	13.7
Z	10.7	8.0	4.3	4.7	7.6	10.7

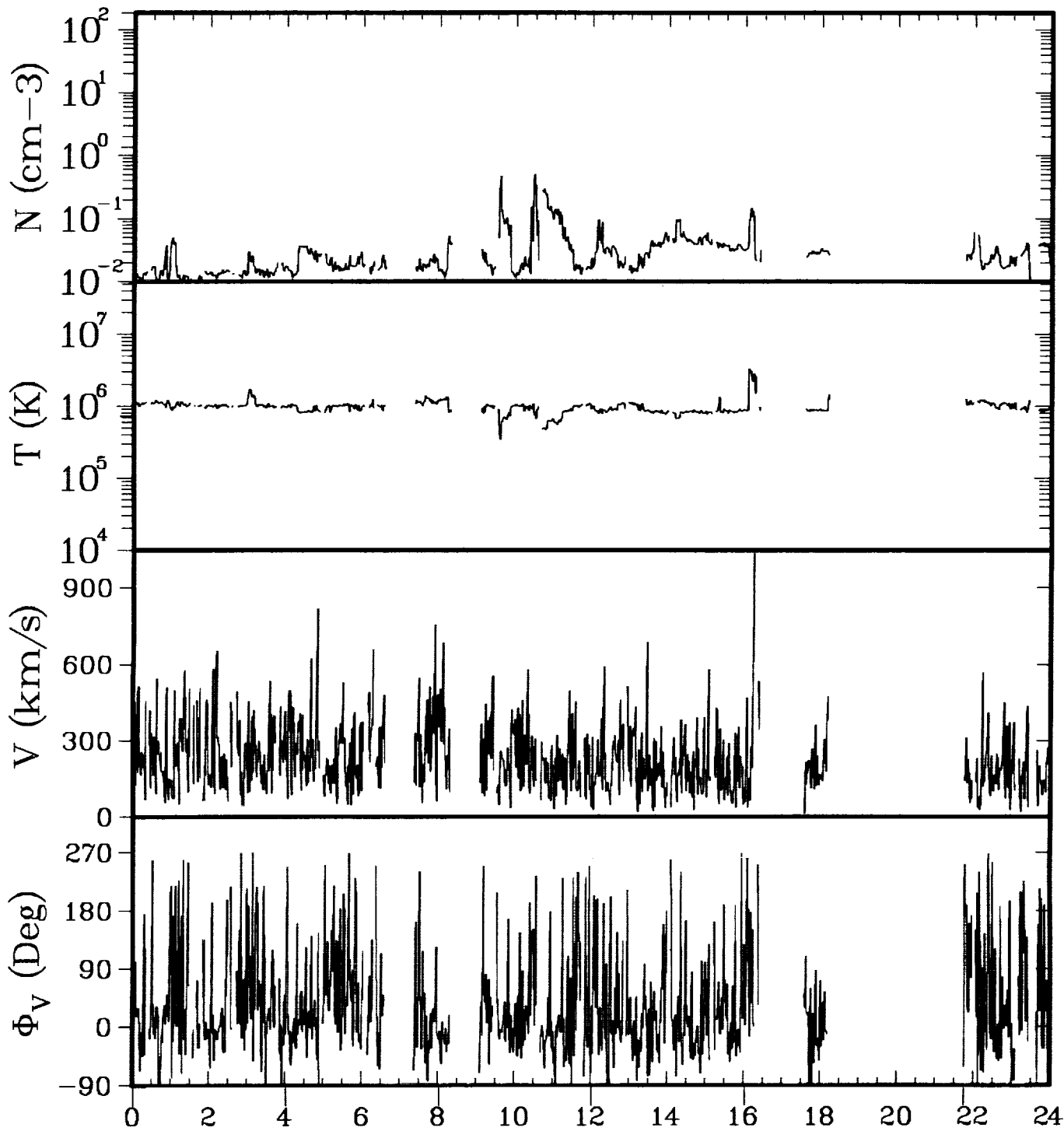

ISEE-3 ELECTRONS 12/25/82

GSEX	-50.6	-53.3	-56.0	-58.6	-61.1	-64.5
Y	14.8	14.1	13.4	12.7	12.0	11.0
Z	8.1	8.3	8.4	8.5	8.6	8.7
GSMY	12.5	13.6	14.6	14.0	12.0	8.5
Z	11.4	9.1	6.1	6.1	8.6	11.1

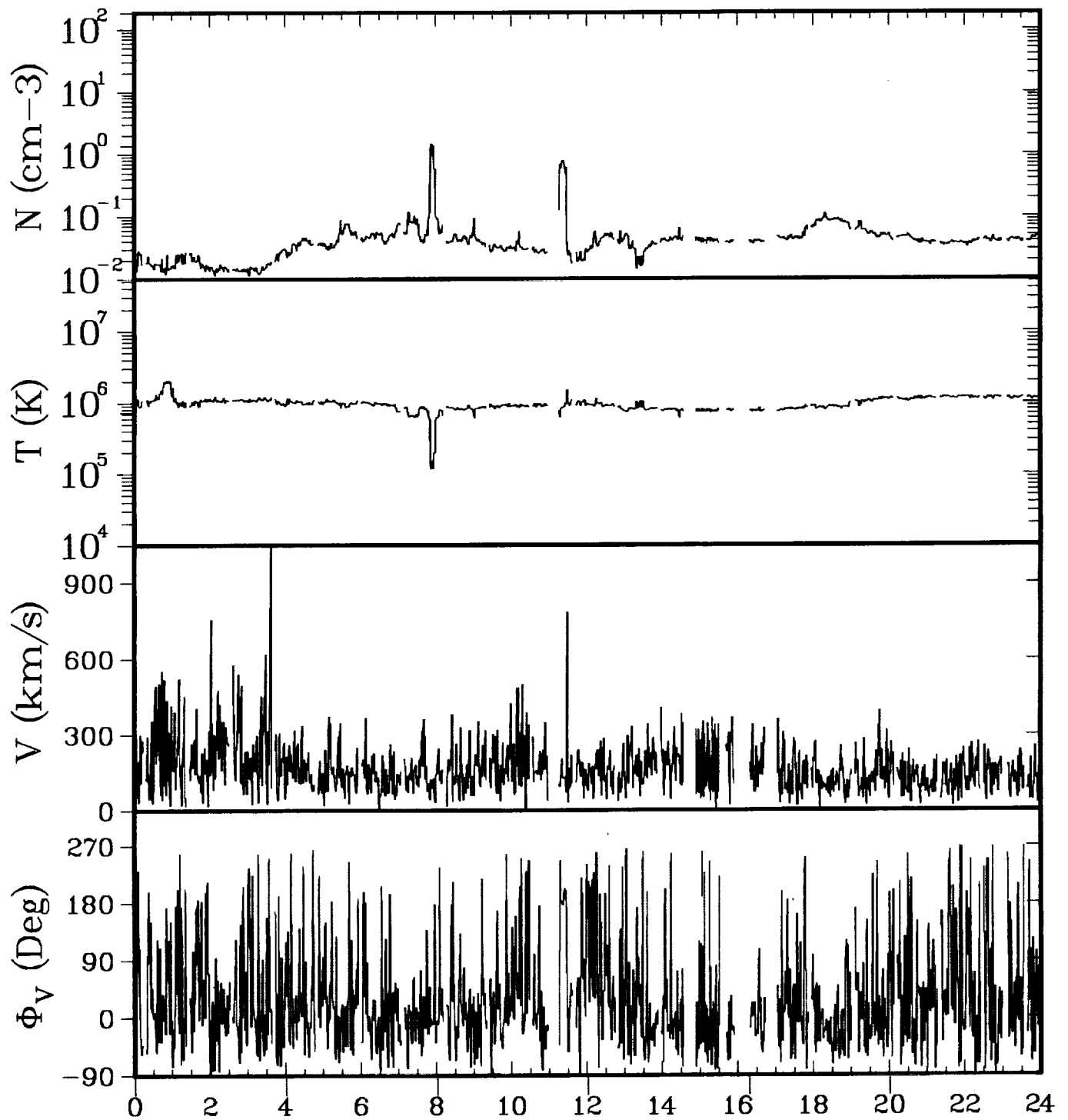

ISEE-3 ELECTRONS 12/26/82

GSEX	-65.8	-68.1	-70.3	-72.5	-74.8	-76.7
Y	10.5	9.8	9.1	8.4	7.7	7.1
Z	8.8	8.9	8.9	9.0	9.0	9.1
GSMY	8.1	9.2	10.4	9.8	7.5	5.1
Z	11.1	9.5	7.4	7.4	9.2	10.3

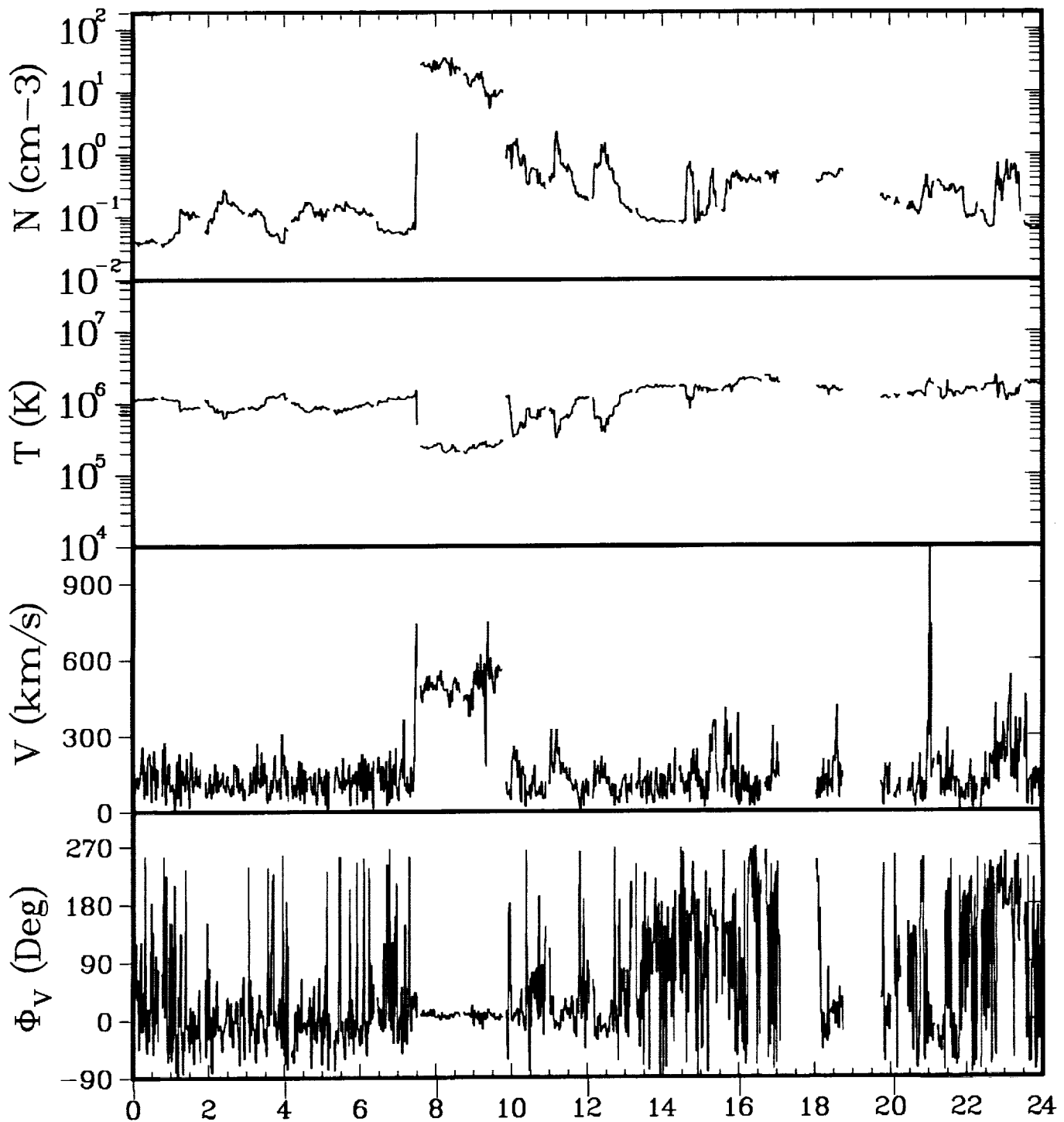

ISEE-3 ELECTRONS 12/27/82

GSEX	-78.7	-80.7	-82.6	-84.5	-86.3	-88.2
Y	6.4	5.7	5.0	4.4	3.7	3.1
Z	9.1	9.2	9.2	9.2	9.2	9.2
GSMY	3.9	5.0	6.3	5.8	3.6	1.1
Z	10.4	9.6	8.3	8.4	9.3	9.7

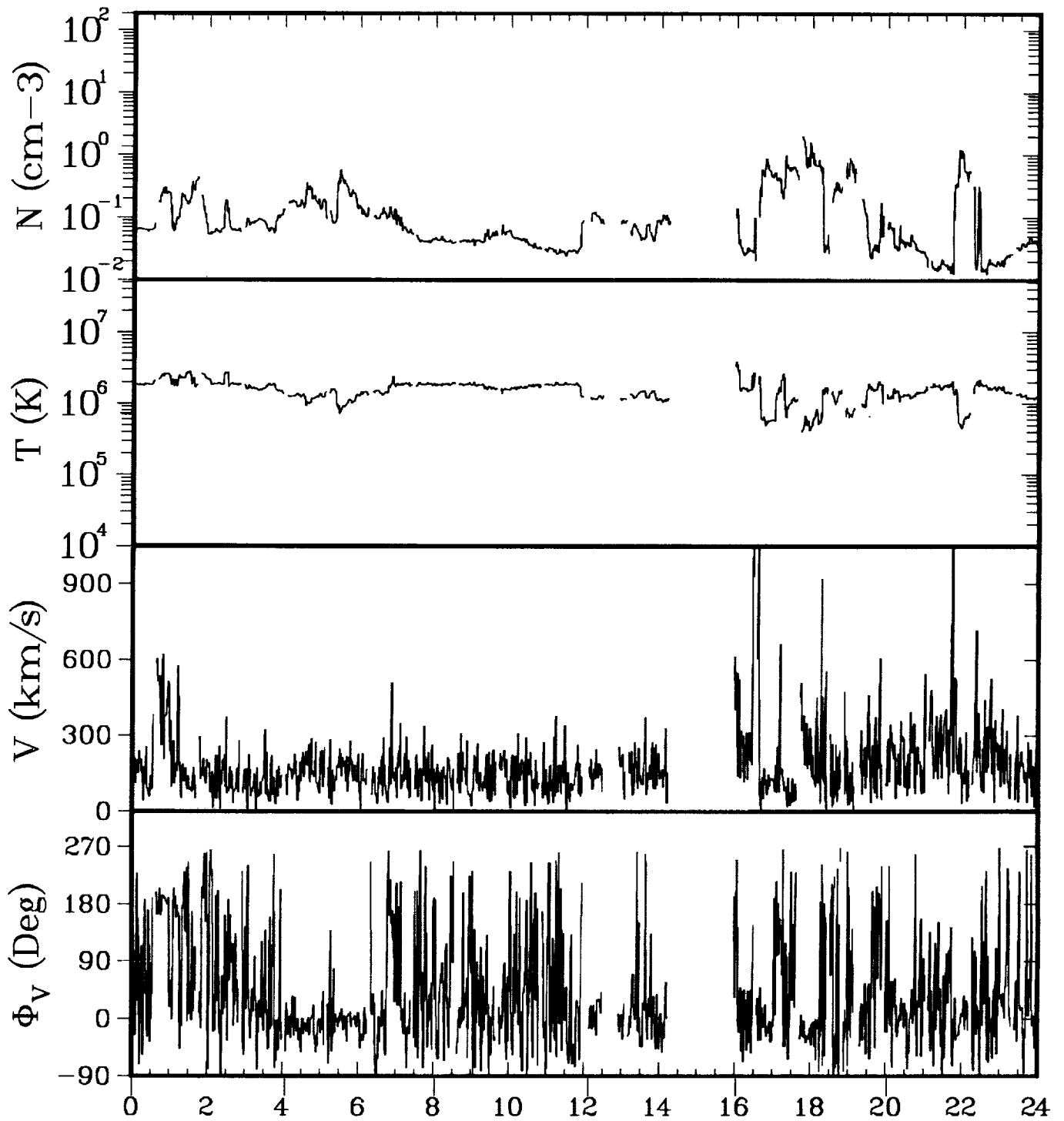

ISEE-3 ELECTRONS 12/28/82

GSEX	-89.9	-91.7	-93.3	-95.0	-96.7	-98.3
Y	2.5	1.8	1.2	0.6	0.0	-0.5
Z	9.2	9.2	9.2	9.2	9.2	9.2
GSMY	0.0	1.1	2.5	2.0	-0.1	-2.5
Z	9.6	9.3	9.0	9.0	9.2	8.9

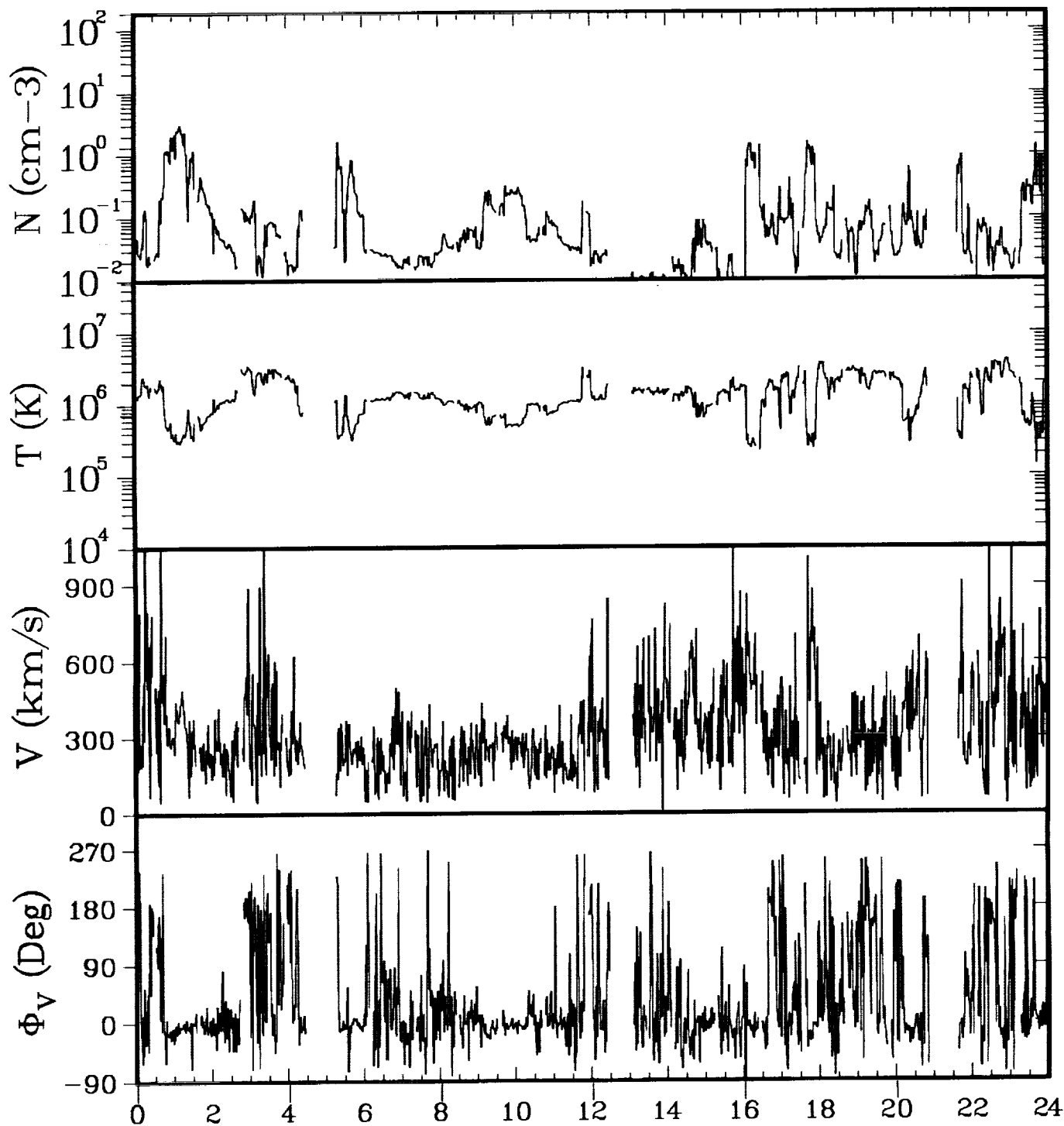

ISEE-3 ELECTRONS 12/29/82

GSEX	-99.8	-101.4	-102.9	-104.4	-105.9	-107.3
Y	-1.1	-1.7	-2.2	-2.8	-3.3	-3.8
Z	9.2	9.2	9.1	9.1	9.1	9.0
GSMY	-3.5	-2.5	-1.0	-1.4	-3.5	-5.7
Z	8.6	9.0	9.3	9.4	9.0	8.0

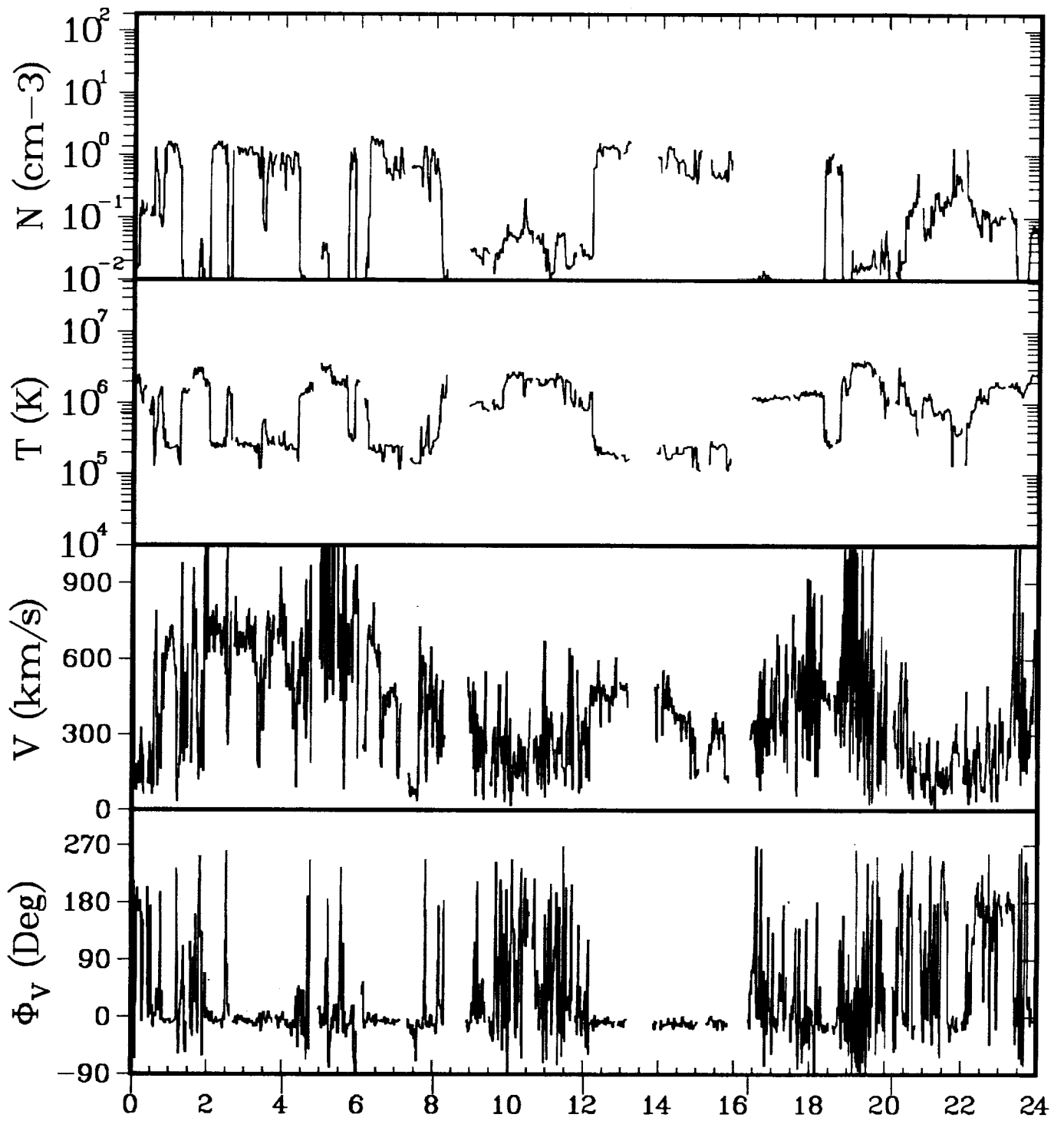

ISEE-3 ELECTRONS 12/30/82

GSEX	-108.7	-110.1	-111.5	-112.9	-114.3	-115.6
Y	-4.3	-4.8	-5.3	-5.8	-6.3	-6.8
Z	9.0	9.0	8.9	8.9	8.8	8.8
GSMY	-6.6	-5.7	-4.2	-4.5	-6.8	-8.6
Z	7.5	8.4	9.5	9.6	8.5	7.0

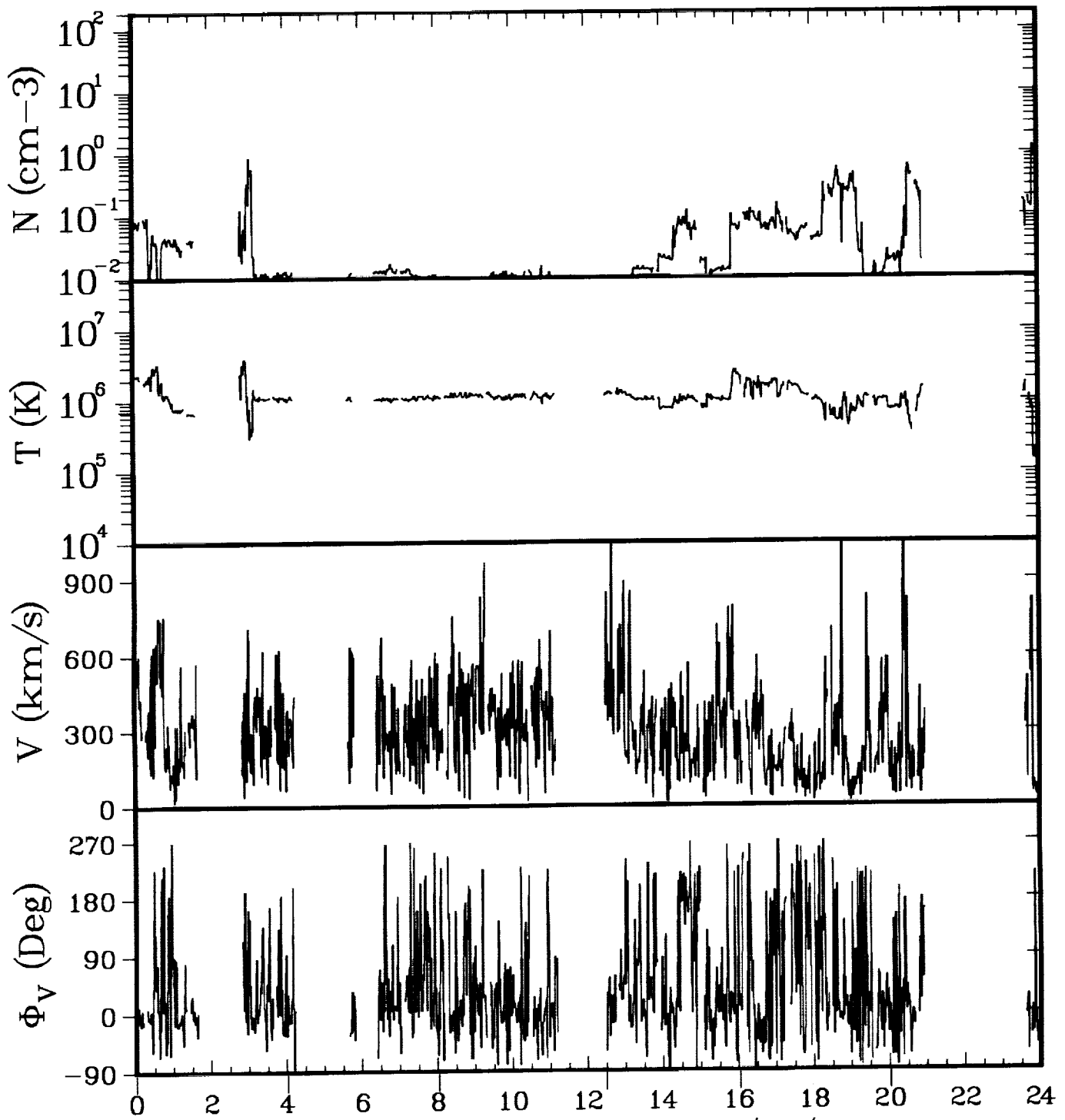

ISEE-3 ELECTRONS 12/31/82

GSEX	-116.8	-118.1	-119.3	-120.7	-121.8	-123.0
Y	-7.2	-7.7	-8.1	-8.6	-8.9	-9.4
Z	8.8	8.7	8.6	8.6	8.5	8.5
GSMY	-9.4	-8.6	-7.1	-7.5	-9.3	-11.1
Z	6.4	7.8	9.5	9.6	8.2	6.0

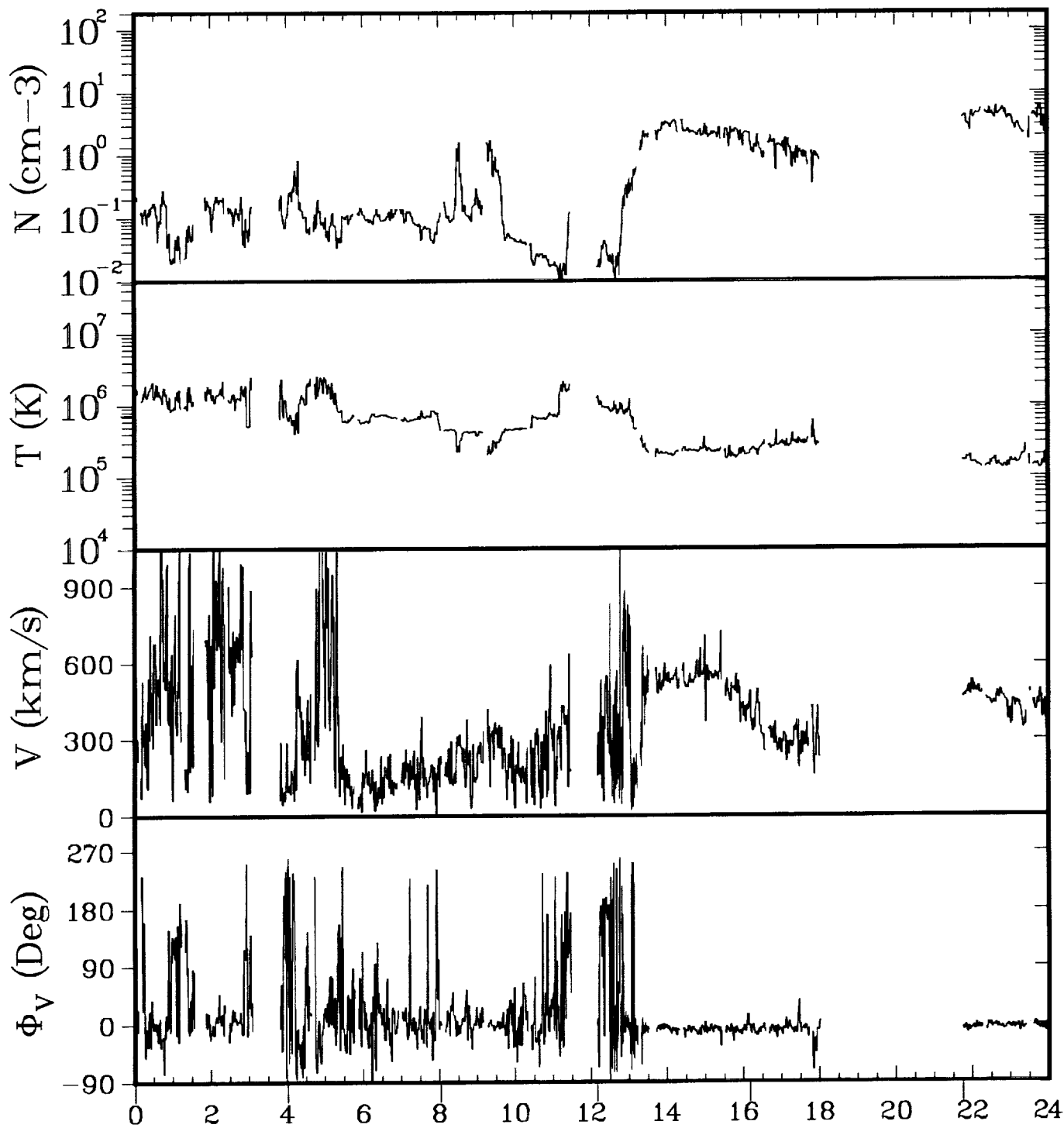

ISEE-3 ELECTRONS 01/01/83

GSEX	-124.2	-125.3	-126.5	-127.7	-128.8	-130.3
Y	-9.8	-10.2	-10.5	-10.9	-11.3	-11.8
Z	8.4	8.4	8.3	8.2	8.2	8.1
GSMY	-11.8	-11.1	-9.6	-9.9	-11.7	-13.6
Z	5.3	7.1	9.4	9.5	7.5	4.3

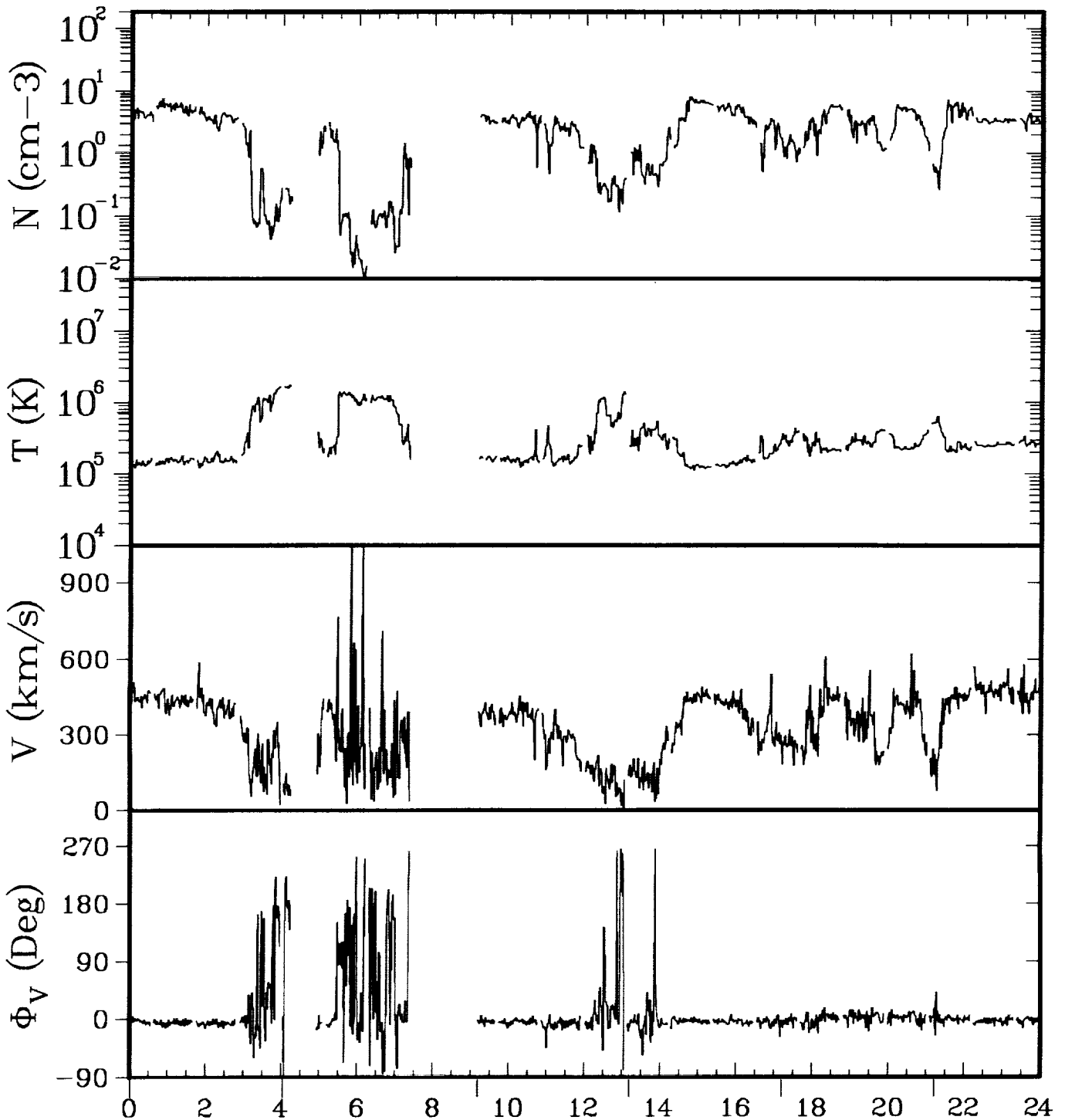

ISEE-3 ELECTRONS 01/02/83

GSEX	-130.9	-132.0	-133.4	-134.4	-135.4	-136.5
Y	-12.0	-12.3	-12.8	-13.1	-13.4	-13.7
Z	8.0	8.0	7.9	7.8	7.7	7.7
GSMY	-13.8	-13.2	-11.6	-12.4	-14.2	-15.3
Z	4.2	6.4	9.4	8.8	6.1	3.4

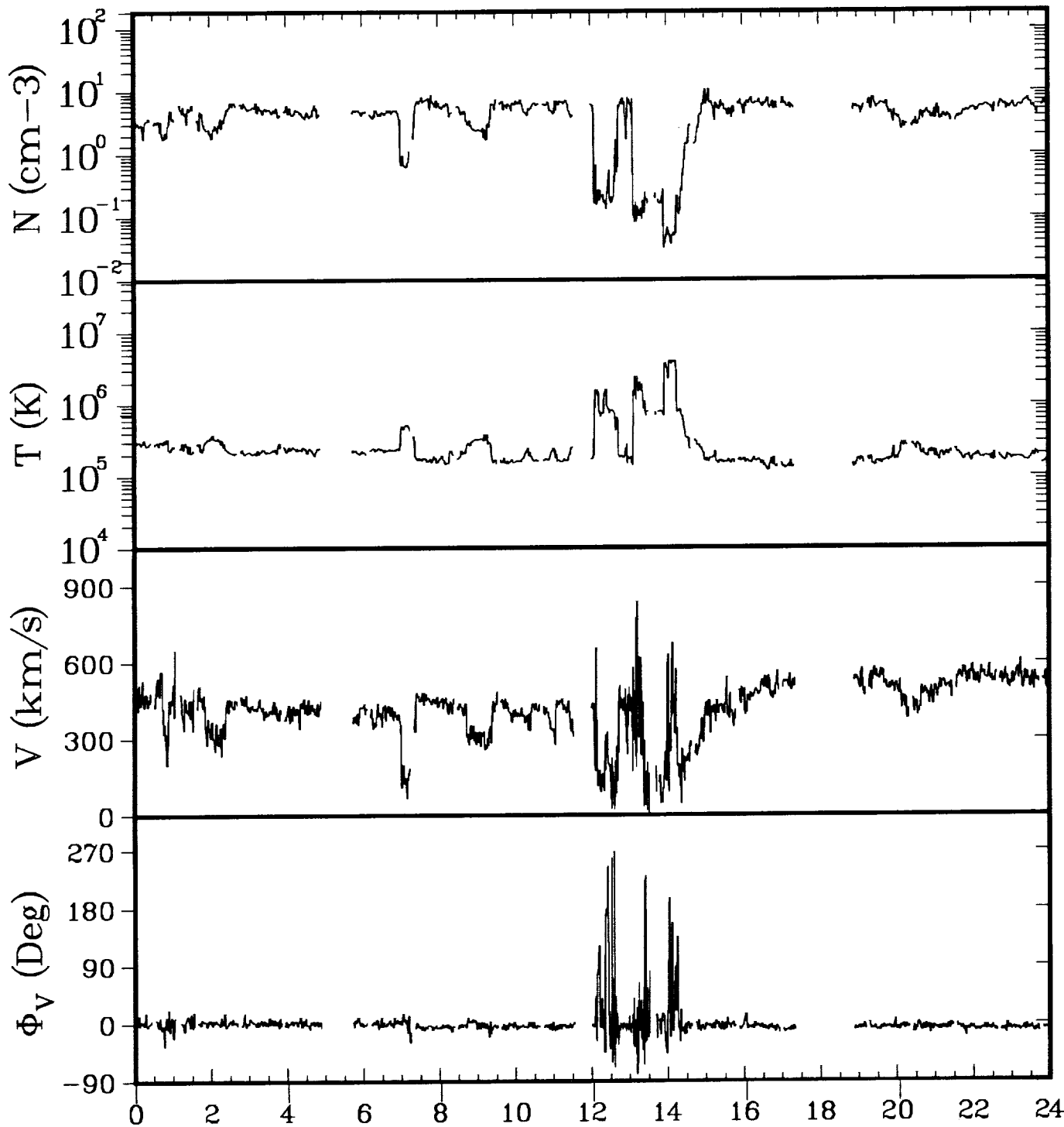

ISEE-3 ELECTRONS 01/03/83

GSEX	-137.2	-138.2	-139.1	-140.1	-141.1	-142.0
Y	-13.9	-14.2	-14.5	-14.7	-15.0	-15.3
Z	7.6	7.5	7.5	7.4	7.3	7.2
GSMY	-15.5	-15.1	-13.7	-13.9	-15.4	-16.6
Z	3.1	5.6	8.7	8.9	6.4	3.0

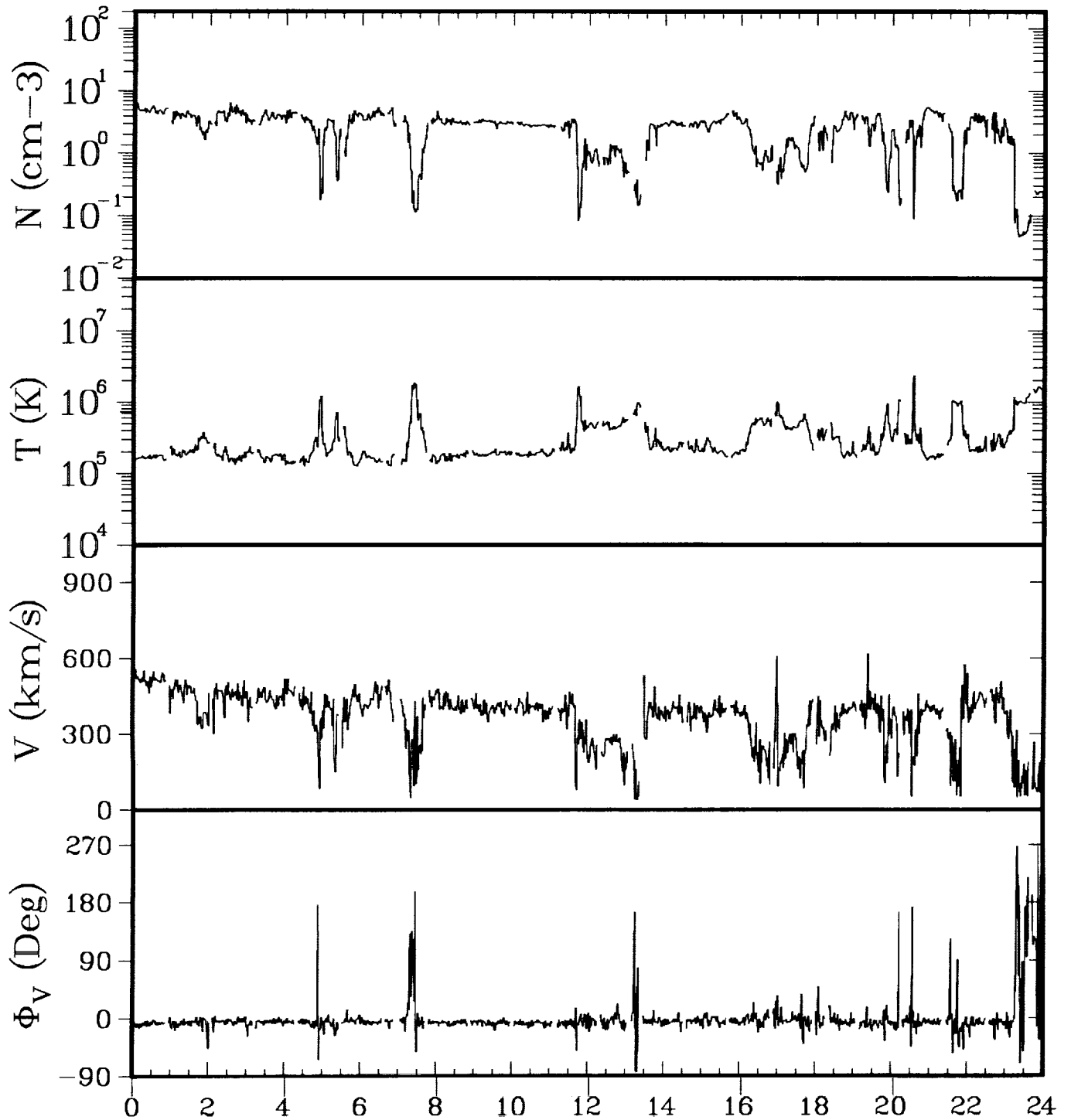

ISEE-3 ELECTRONS 01/04/83

GSEX	-143.0	-143.9	-144.8	-145.7	-146.6	-147.5
Y	-15.5	-15.8	-16.0	-16.2	-16.4	-16.6
Z	7.1	7.1	7.0	6.9	6.8	6.7
GSMY	-17.0	-16.6	-15.4	-15.4	-16.9	-17.8
Z	2.0	4.8	8.3	8.5	5.7	2.1

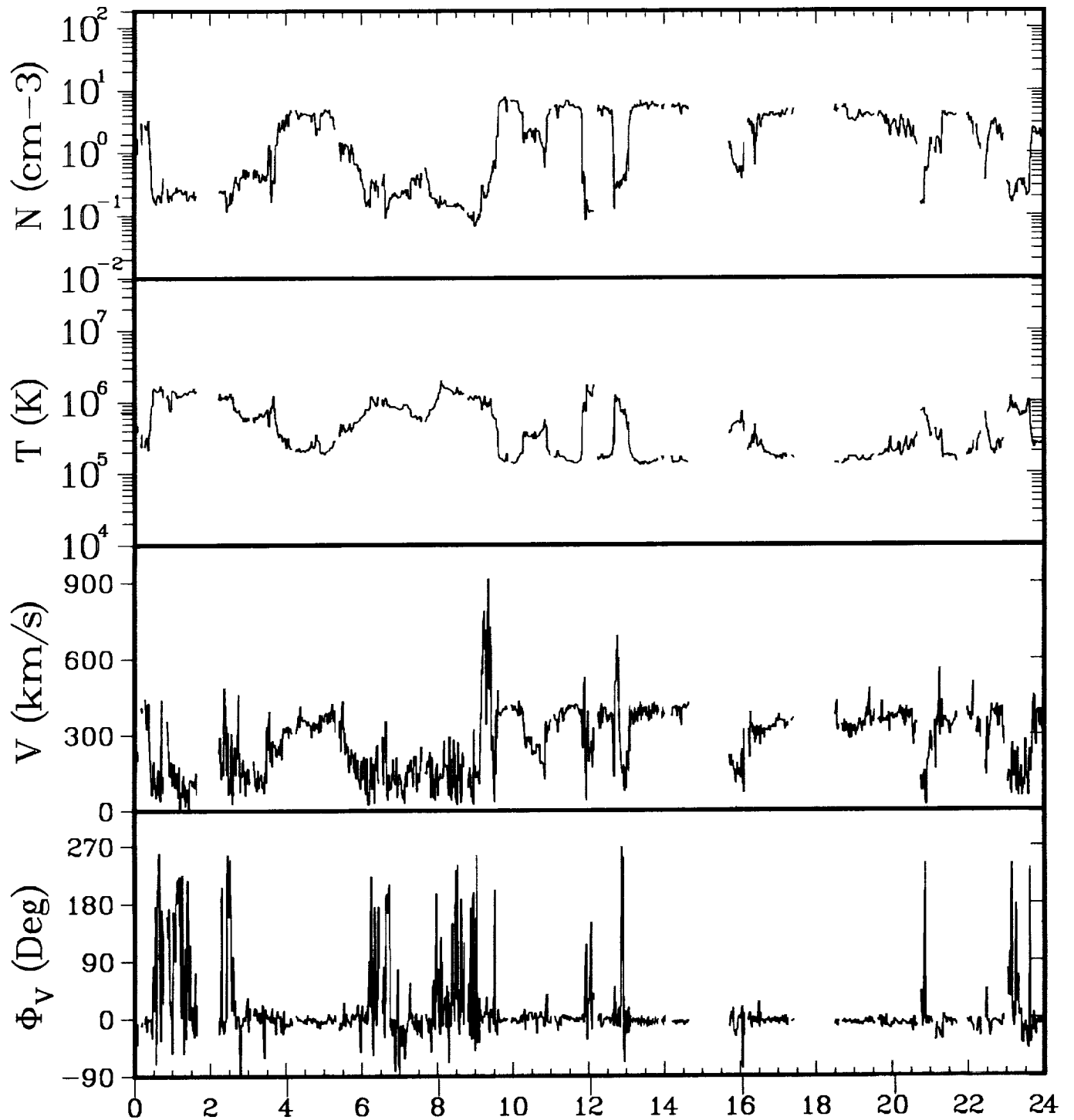

ISEE-3 ELECTRONS 01/05/83

GSEX	-148.3	-149.2	-150.1	-150.9	-151.8	-152.6
Y	-16.8	-17.0	-17.2	-17.4	-17.6	-17.7
Z	6.6	6.5	6.5	6.4	6.3	6.2
GSMY	-18.1	-17.8	-16.7	-16.7	-18.0	-18.7
Z	1.0	3.9	7.7	8.0	4.9	1.1

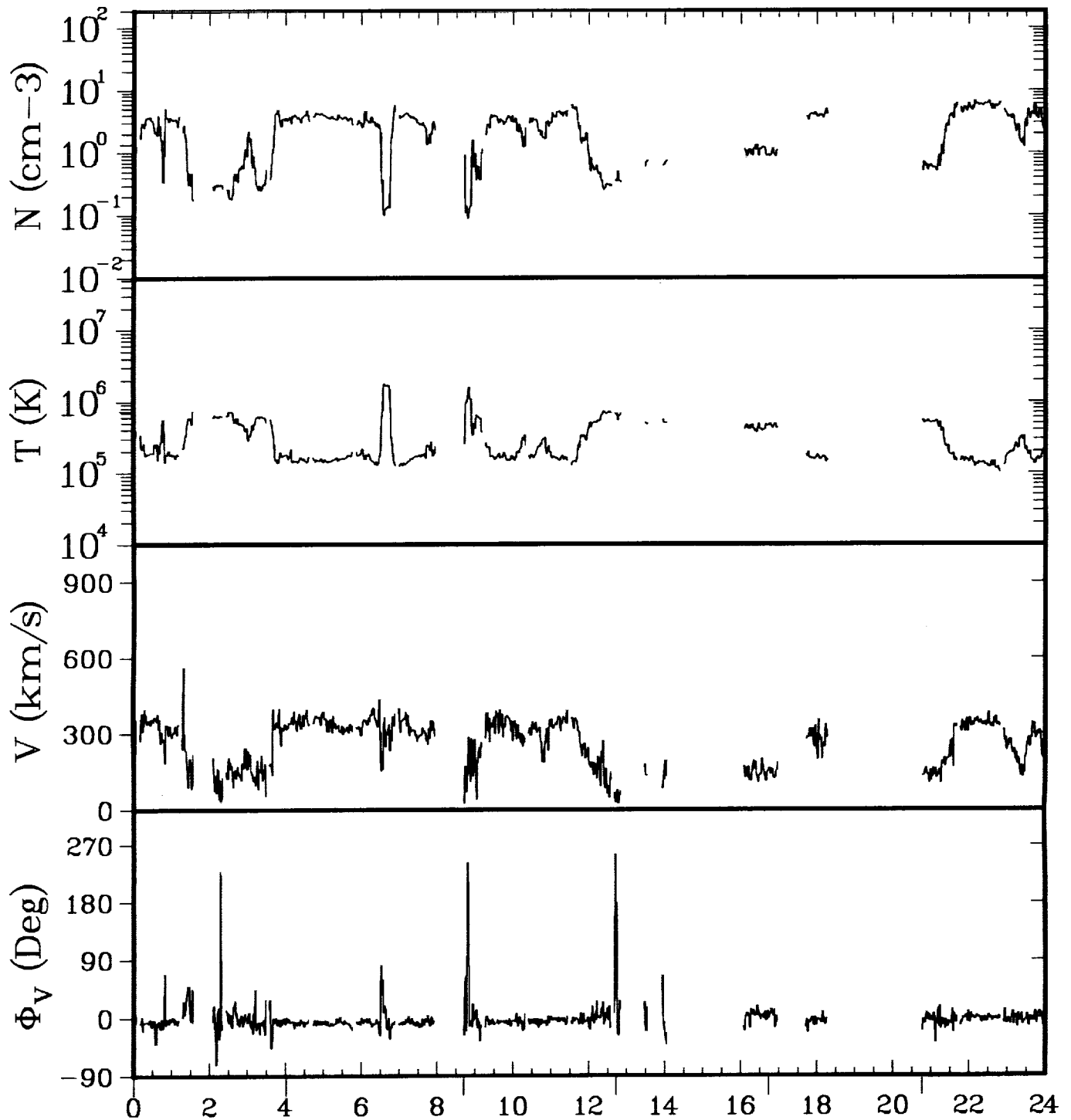

ISEE-3 ELECTRONS 01/06/83

GSEX	-153.4	-154.2	-155.1	-155.9	-156.7	-157.5
Y	-17.9	-18.0	-18.2	-18.3	-18.4	-18.6
Z	6.1	6.0	5.9	5.8	5.7	5.6
GSMY	-18.9	-18.7	-17.6	-17.9	-19.0	-19.4
Z	0.0	3.1	7.5	7.0	3.5	-0.2

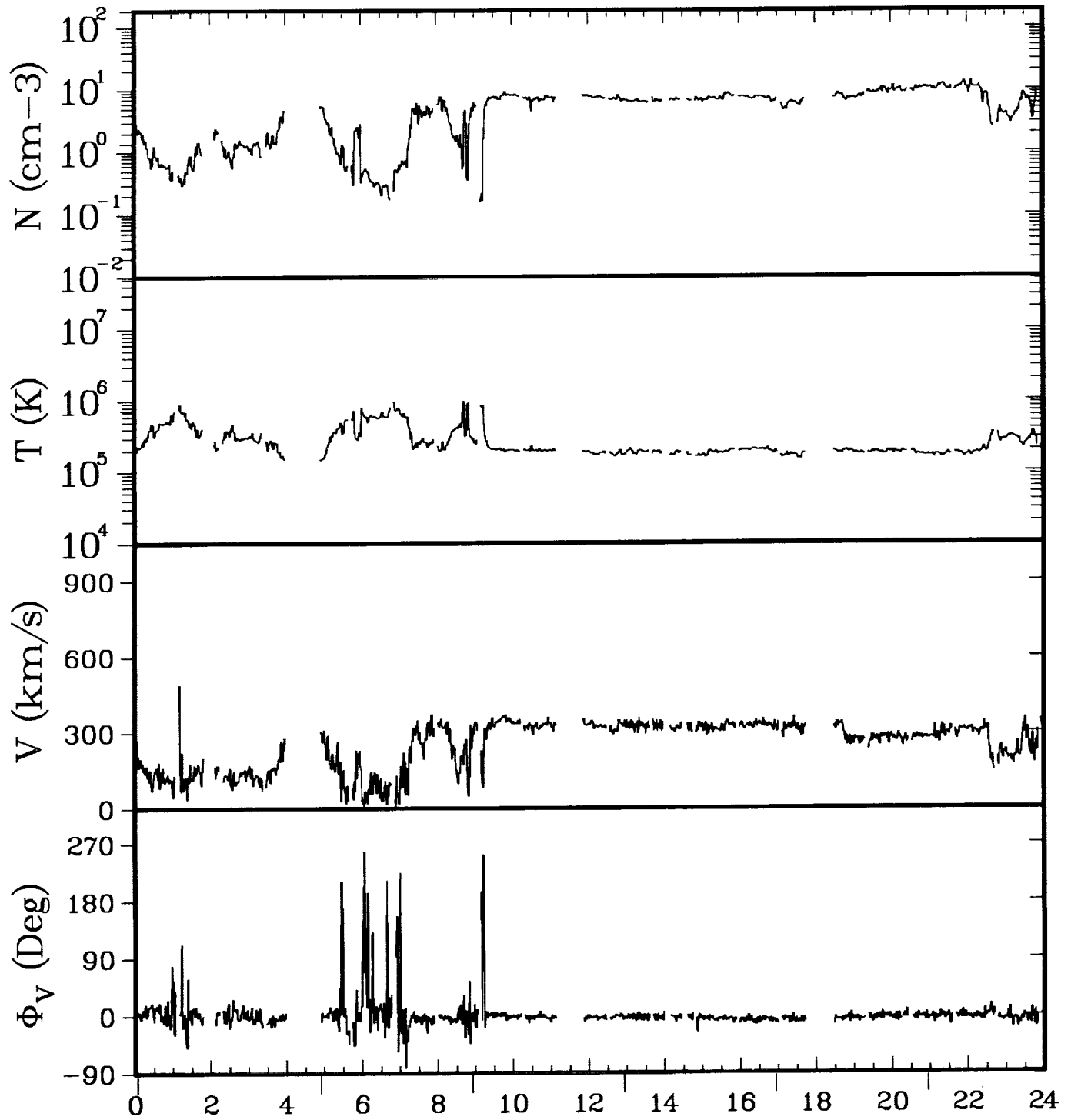

ISEE-3 ELECTRONS 01/07/83

GSEX	-158.1	-159.1	-159.8	-160.6	-161.3	-162.0
Y	-18.7	-18.8	-18.9	-19.0	-19.0	-19.1
Z	5.5	5.4	5.3	5.2	5.1	5.0
GSMY	-19.4	-19.3	-18.4	-18.6	-19.6	-19.7
Z	-0.9	3.4	6.9	6.2	2.5	-1.2

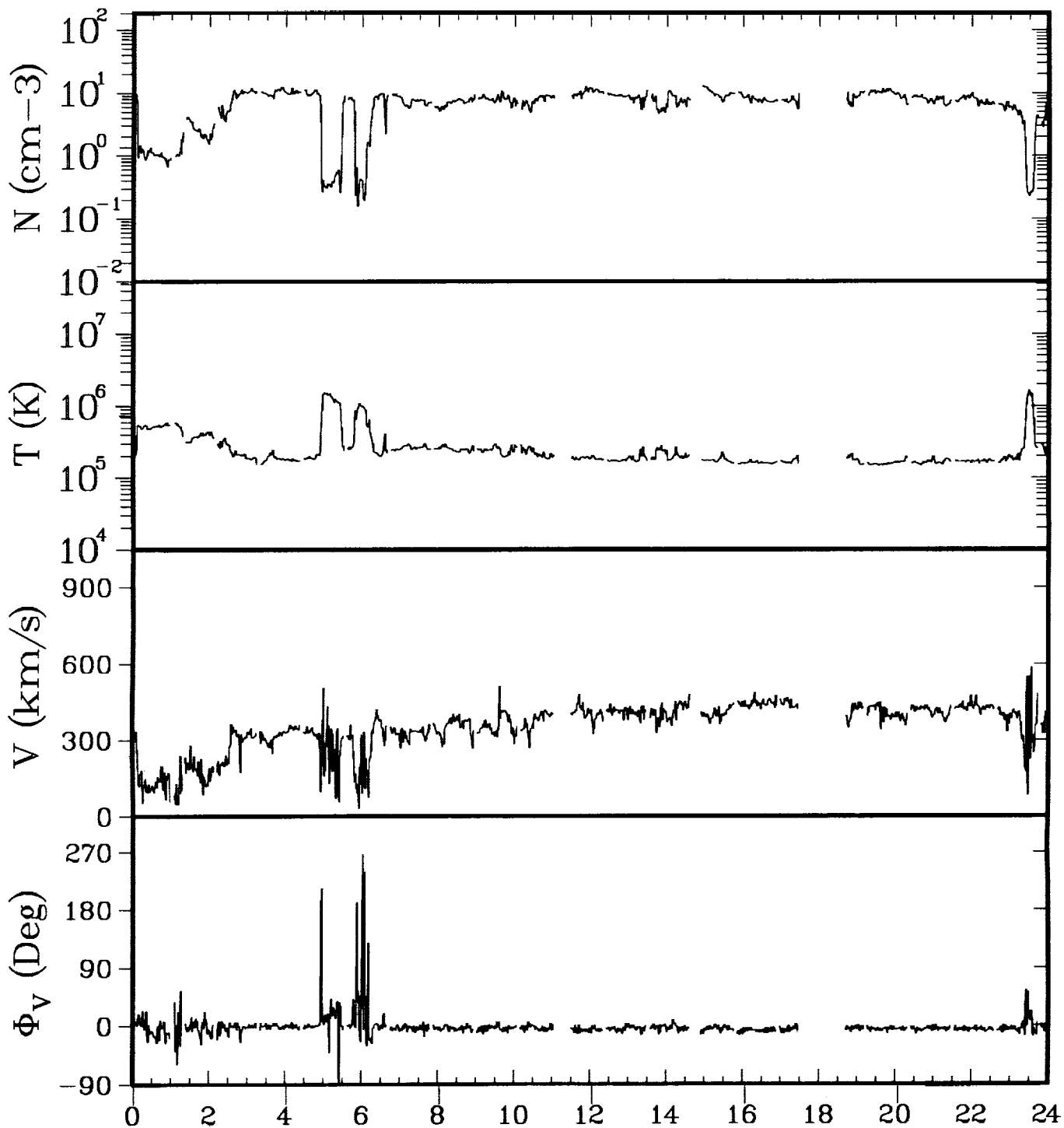

ISEE-3 ELECTRONS 01/08/83

GSEX	-162.6	-163.3	-164.0	-164.7	-165.4	-166.1
Y	-19.2	-19.2	-19.3	-19.3	-19.4	-19.4
Z	5.0	4.9	4.8	4.7	4.6	4.5
GSMY	-19.7	-19.8	-19.0	-19.0	-19.7	-19.9
Z	-1.8	1.5	5.7	6.0	2.7	-1.4

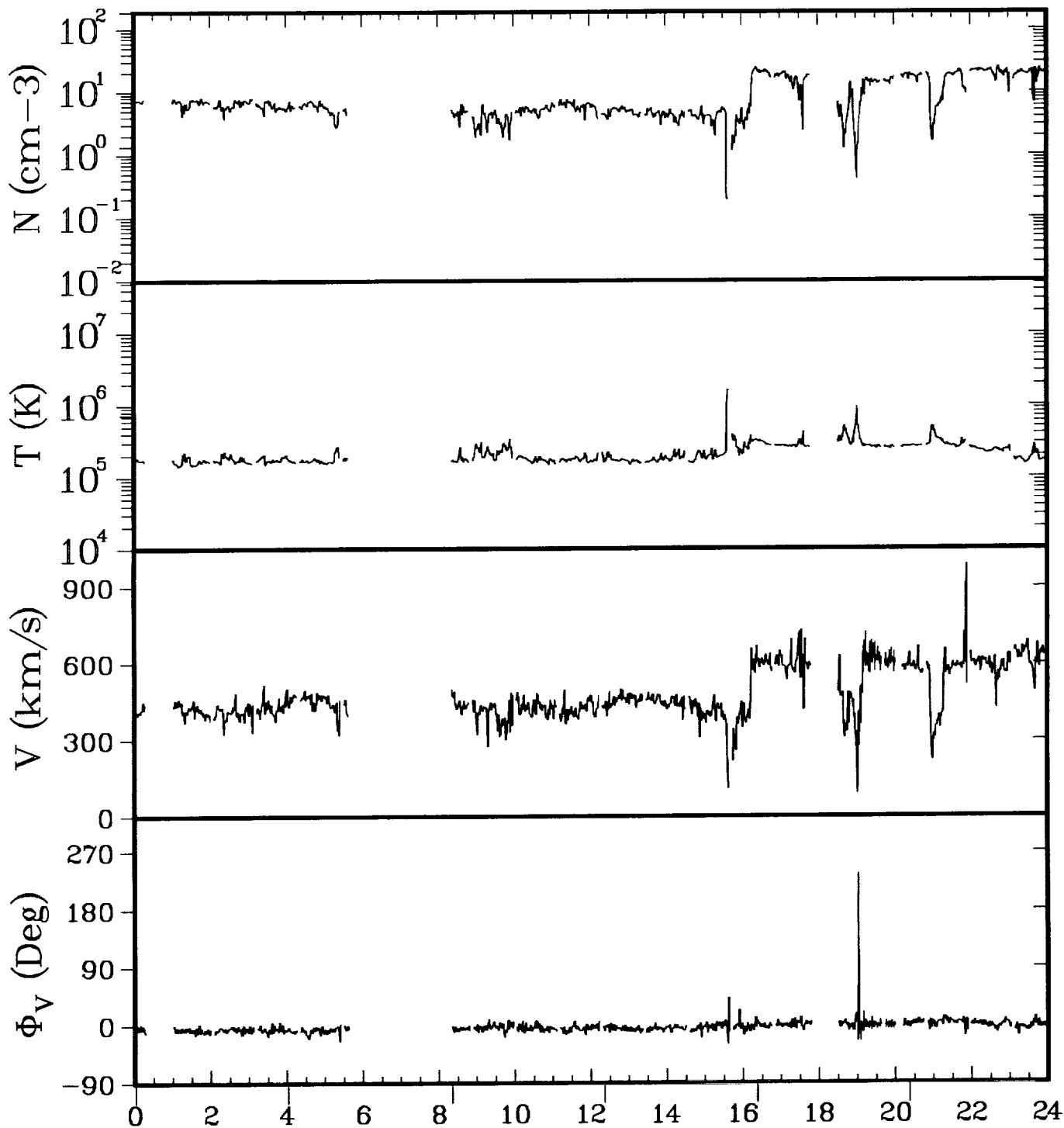

ISEE-3 ELECTRONS 01/09/83

GSEX	-166.8	-167.5	-168.2	-168.9	-169.5	-170.2
Y	-19.5	-19.5	-19.5	-19.5	-19.5	-19.5
Z	4.4	4.3	4.1	4.0	3.9	3.8
GSMY	-19.8	9.9	-19.2	-19.2	-19.8	-19.7
Z	-2.6	0.7	5.2	5.2	1.6	-2.4

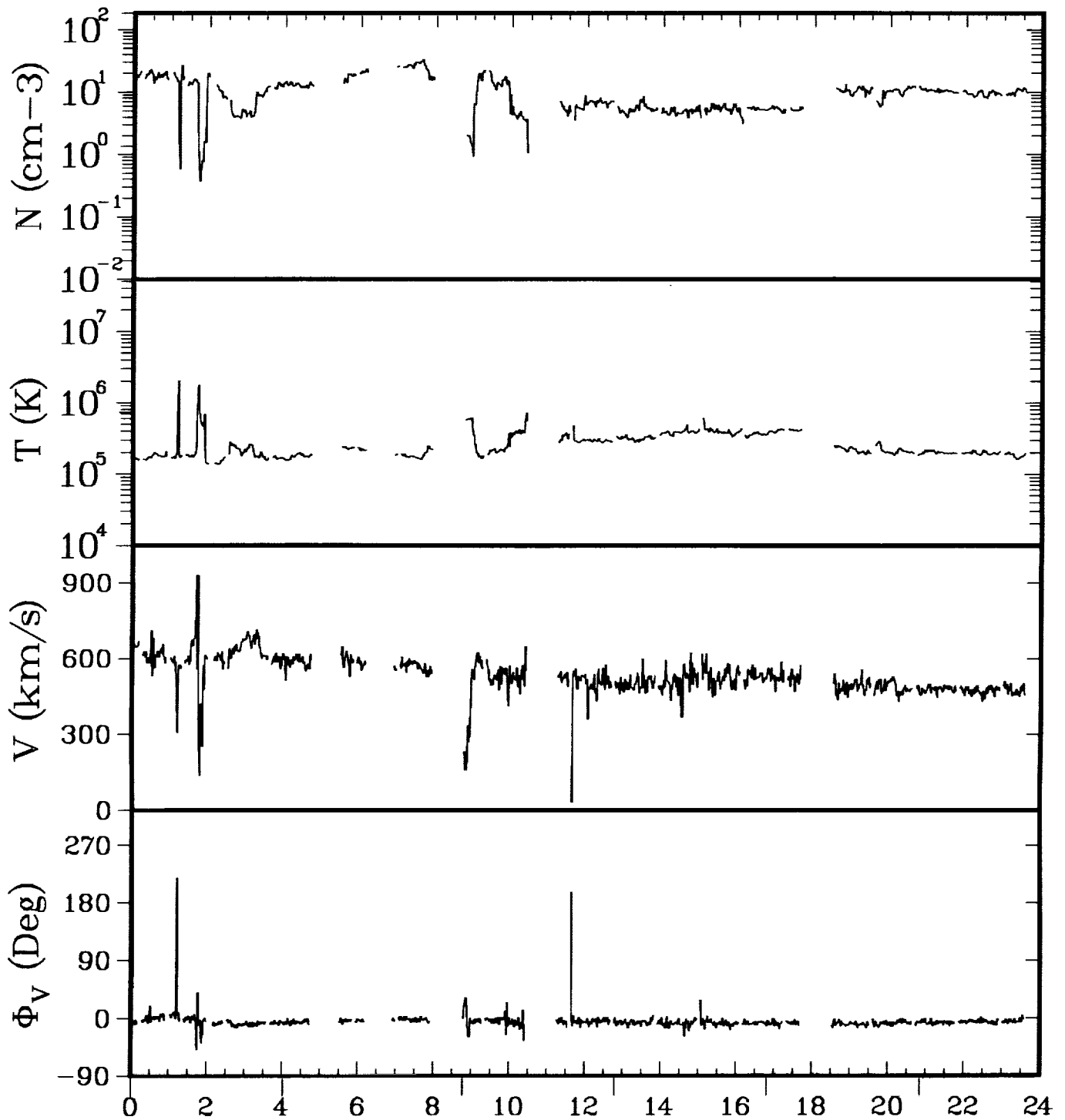

ISEE-3 ELECTRONS 01/10/83

GSEX	-170.8	-171.4	-172.2	-172.8	-173.4	-174.0
Y	-19.5	-19.5	-19.5	-19.5	-19.4	-19.4
Z	3.7	3.6	3.5	3.4	3.3	3.2
GSMY	-19.6	-19.8	-19.2	-19.3	-19.7	-19.4
Z	-3.3	-0.1	4.7	4.1	0.4	-3.4

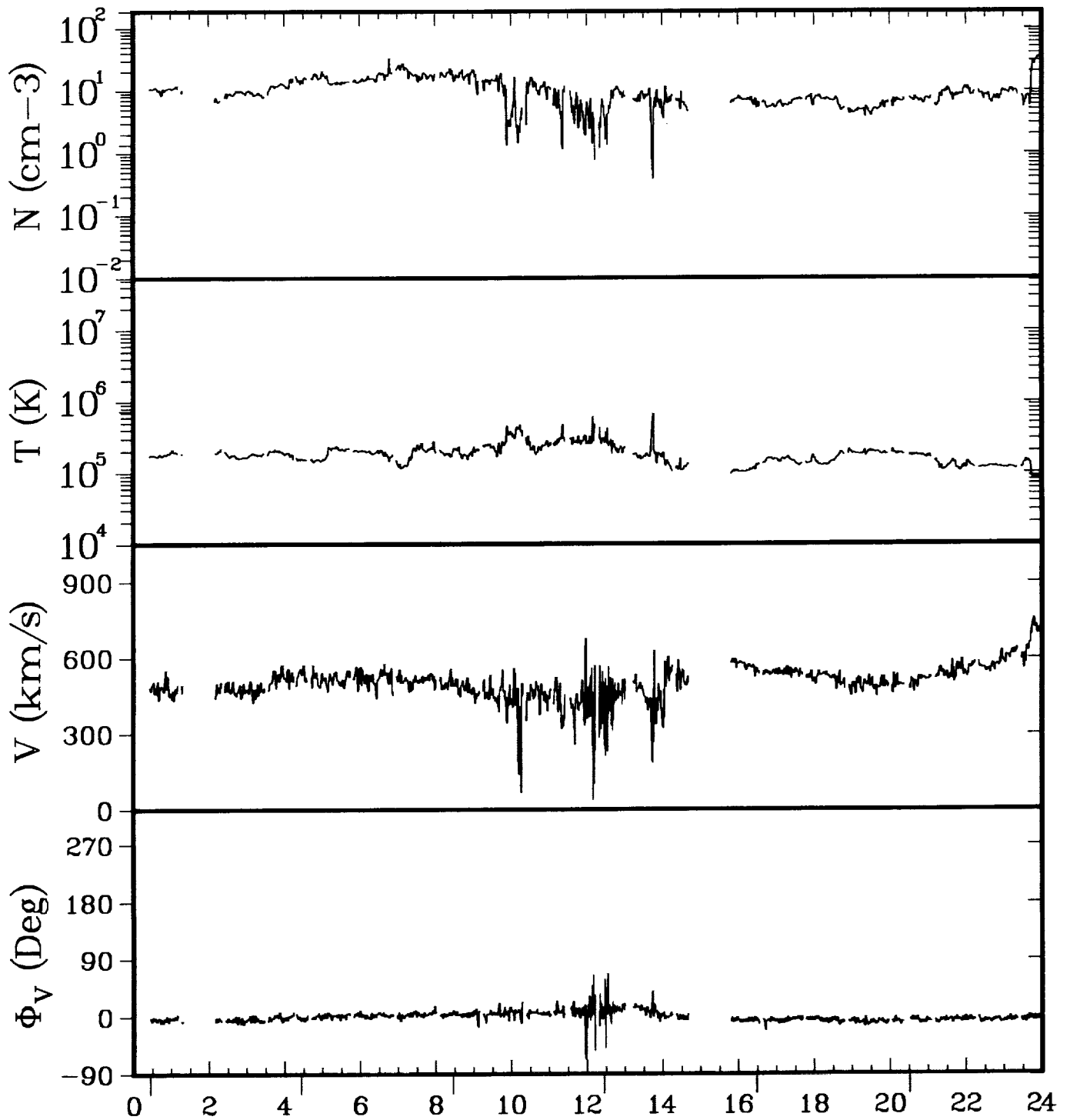

ISEE-3 ELECTRONS 01/11/83

GSEX	-174.6	-175.2	-175.8	-176.4	-177.0	-177.6
Y	-19.4	-19.3	-19.3	-19.2	-19.2	-19.1
Z	3.1	3.0	2.9	2.8	2.7	2.6
GSMY	-19.2	-19.6	-19.1	-19.1	-19.3	-18.9
Z	-3.8	-0.3	3.7	3.6	0.0	-3.8

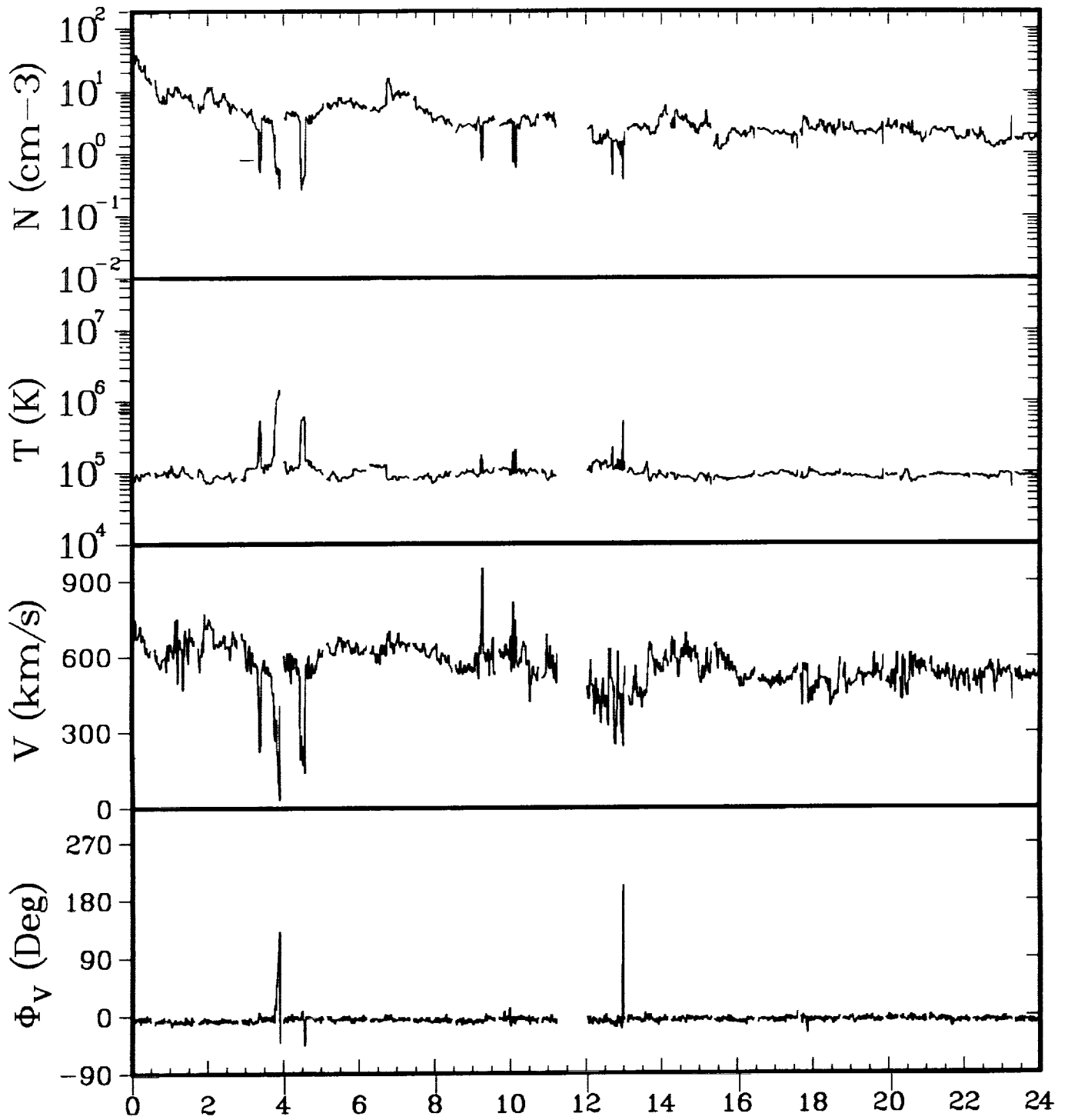

ISEE-3 ELECTRONS 01/12/83

GSEX	-178.1	-178.7	-179.3	-179.8	-180.4	-181.0
Y	-19.0	-19.0	-18.9	-18.8	-18.7	-18.6
Z	2.5	2.4	2.3	2.2	2.1	2.0
GSMY	-18.6	-19.0	-18.8	-18.7	-18.8	-18.3
Z	-4.6	-1.5	2.7	3.0	-0.2	-4.1

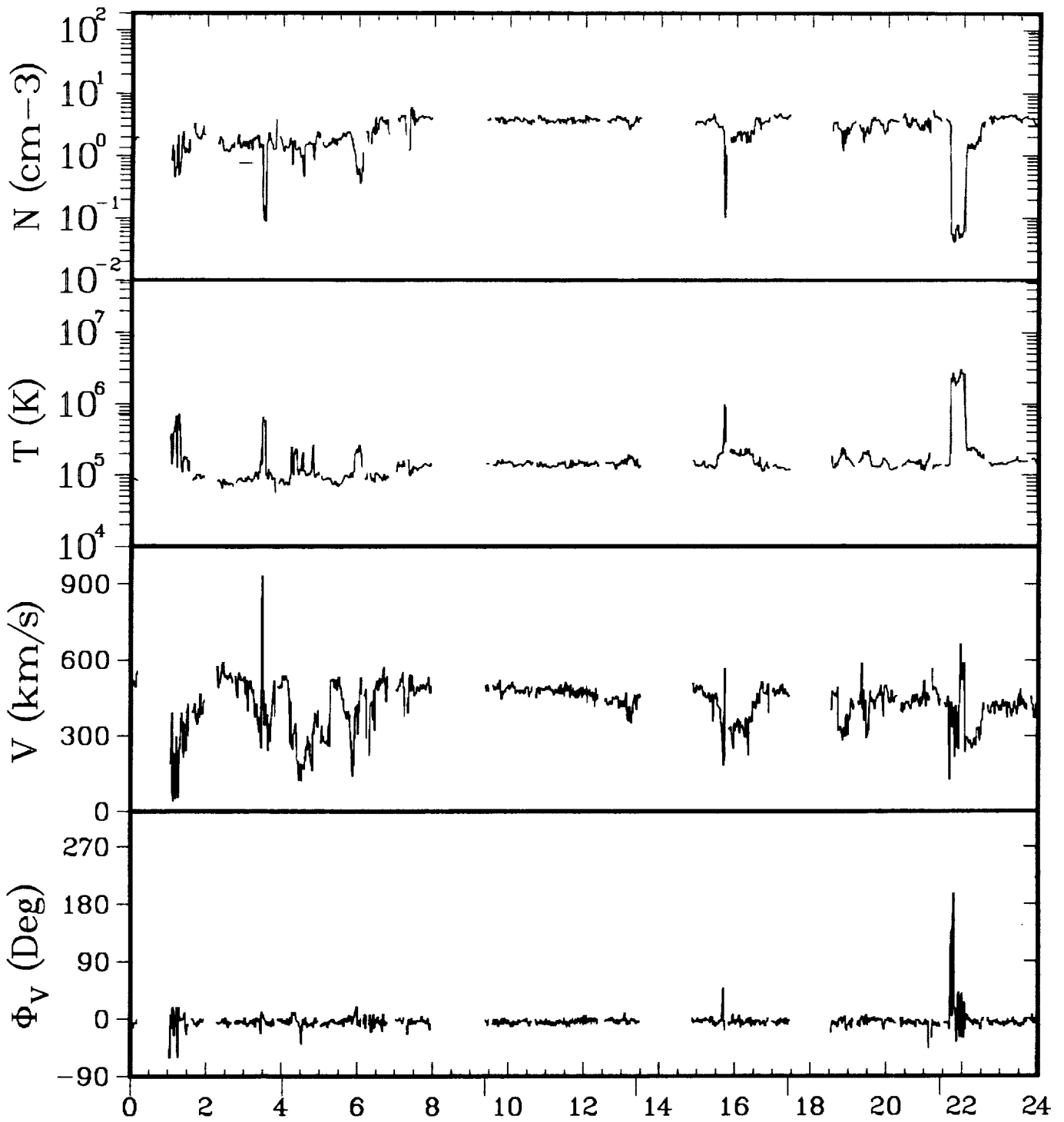

ISEE-3 ELECTRONS 01/13/83

GSEX	-181.5	-182.1	-182.8	-183.4	-183.9	-184.4
Y	-18.5	-18.4	-18.3	-18.2	-18.0	-17.9
Z	1.9	1.7	1.6	1.5	1.4	1.3
GSMY	-17.9	-18.4	-18.2	-18.2	-18.0	-17.2
Z	-5.1	-2.1	2.5	1.4	-2.3	-5.3

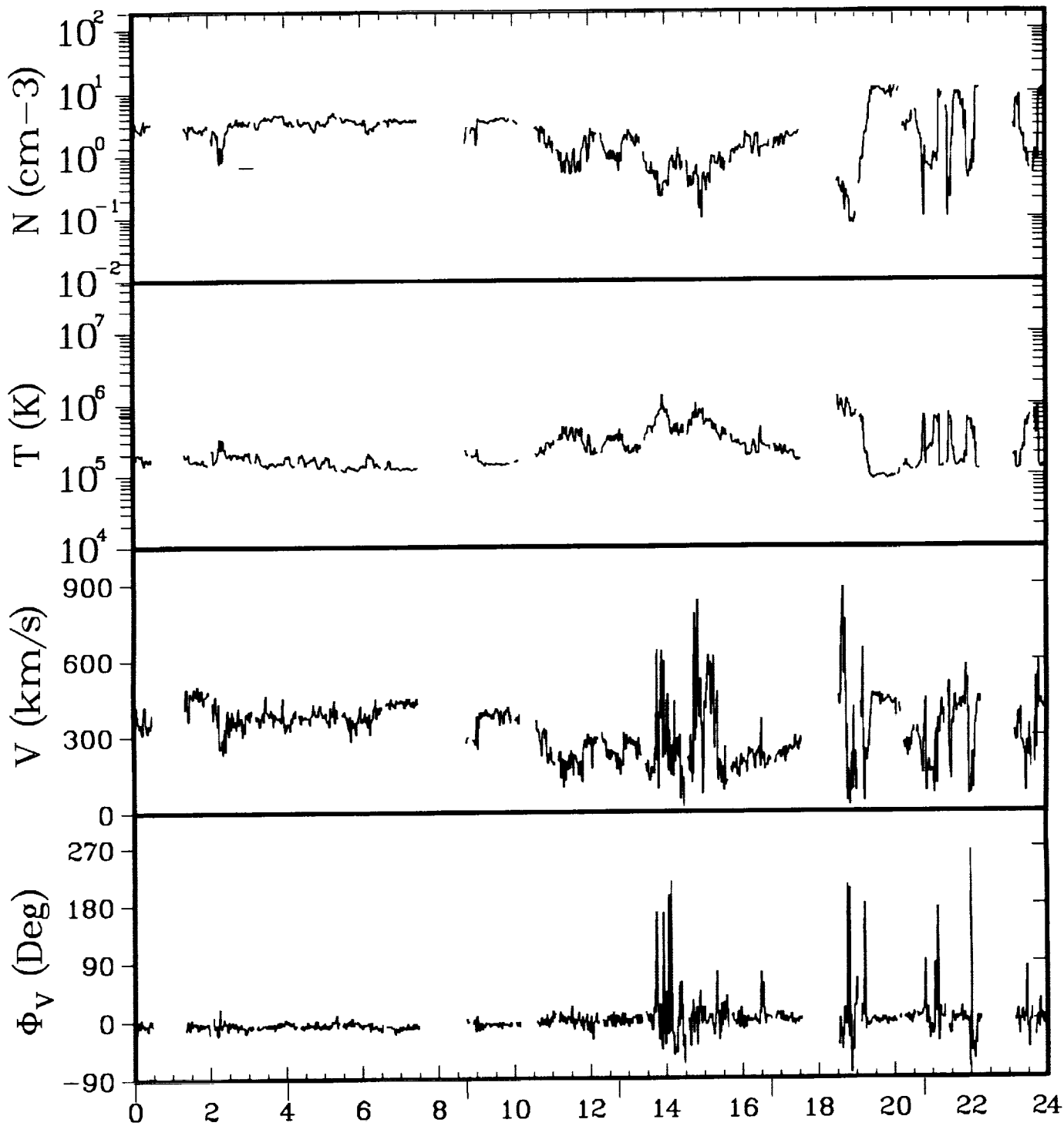

ISEE-3 ELECTRONS 01/14/83

GSEX	-184.8	-185.3	-185.9	-186.4	-186.9	-187.4
Y	-17.8	-17.7	-17.6	-17.4	-17.3	-17.1
Z	1.2	1.1	1.0	0.9	0.8	0.7
GSMY	-17.0	-17.5	-17.5	-17.4	-17.2	-16.3
Z	-5.6	-2.7	1.5	1.1	-2.3	-5.4

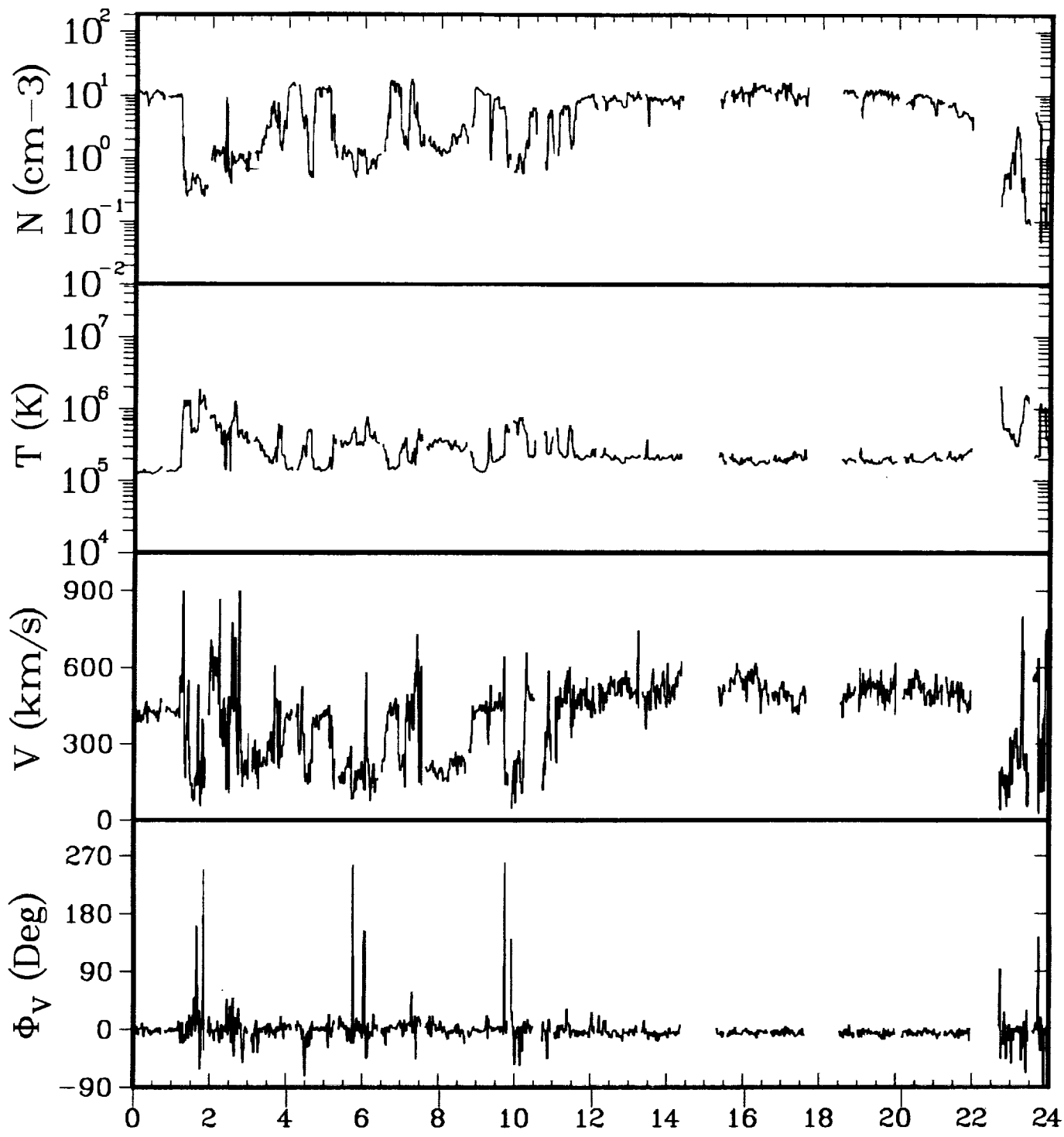

ISEE-3 ELECTRONS 01/15/83

GSEX	-187.8	-188.3	-188.8	-189.3	-189.8	-190.3
Y	-17.0	-16.9	-16.7	-16.6	-16.4	-16.2
Z	0.6	0.5	0.4	0.2	0.1	0.0
GSMY	-16.0	-16.6	-16.7	-16.6	-16.3	-15.3
Z	-6.0	-3.3	0.3	0.6	-2.2	-5.5

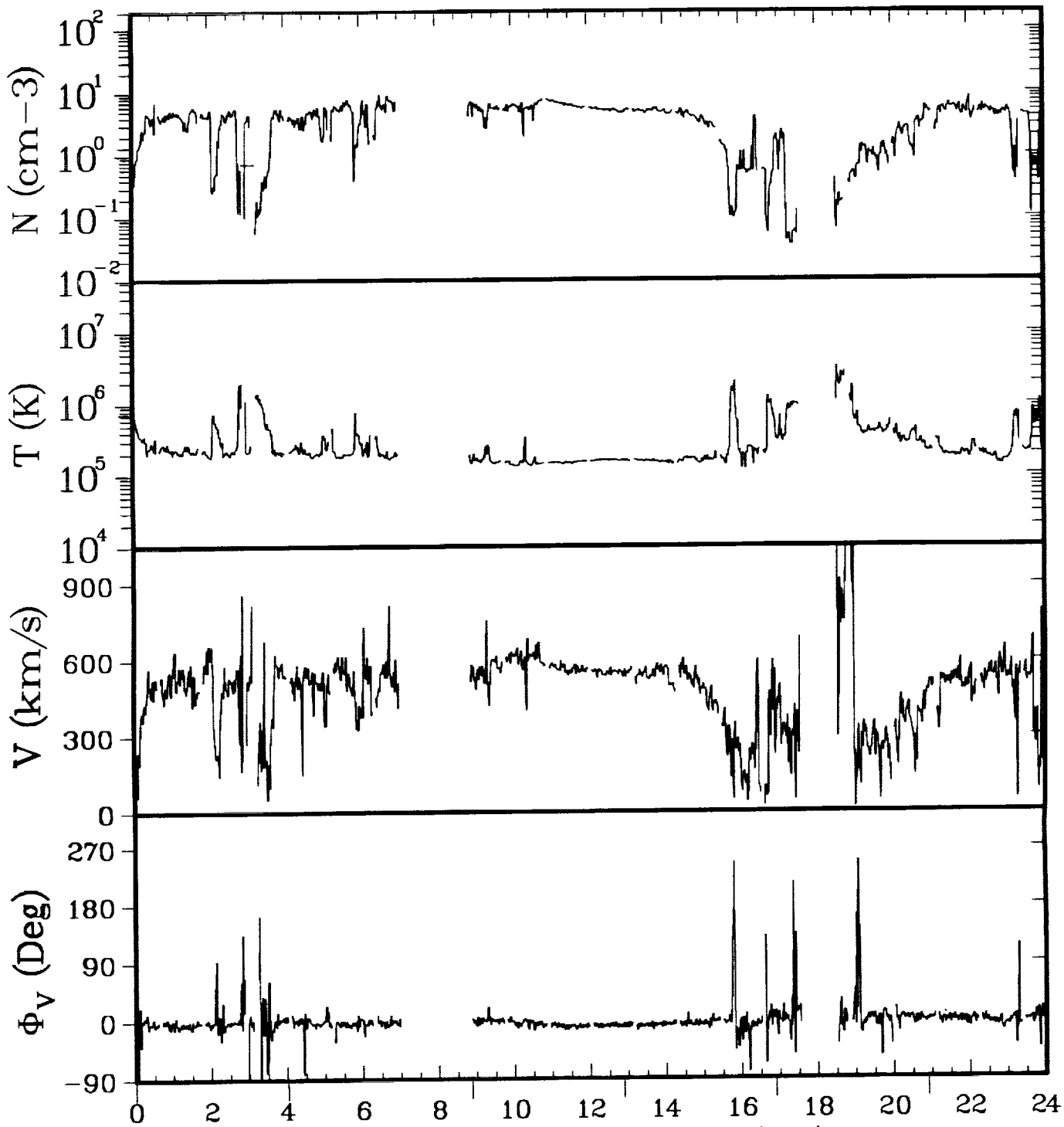

ISEE-3 ELECTRONS 01/16/83

GSEX	-190.8	-191.3	-191.8	-192.3	-192.8	-193.2
Y	-16.1	-15.9	-15.7	-15.5	-15.3	-15.2
Z	-0.1	-0.2	-0.3	-0.4	-0.5	-0.6
GSMY	-14.8	-15.4	-15.7	-15.5	-14.9	-13.9
Z	-6.3	-3.8	-0.1	-0.5	-3.5	-6.2

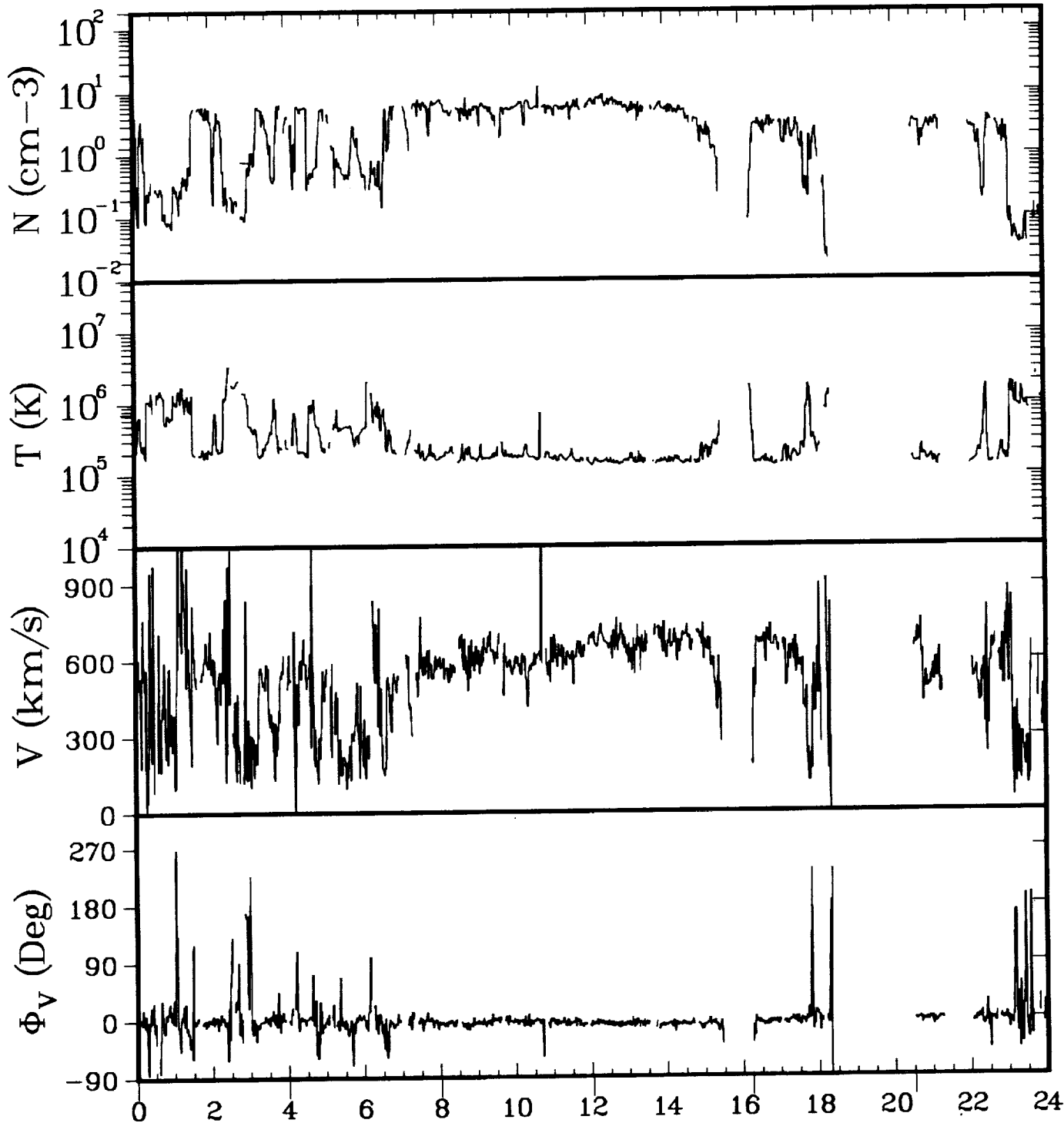

ISEE-3 ELECTRONS 01/17/83

GSEX	-193.6	-194.0	-194.5	-194.9	-195.4	-195.9
Y	-15.0	-14.8	-14.6	-14.4	-14.2	-14.0
Z	-0.7	-0.8	-0.9	-1.0	-1.1	-1.3
GSMY	-13.5	-14.2	-14.6	-14.4	-13.8	-12.6
Z	-6.6	-4.3	-1.2	-0.9	-3.5	-6.3

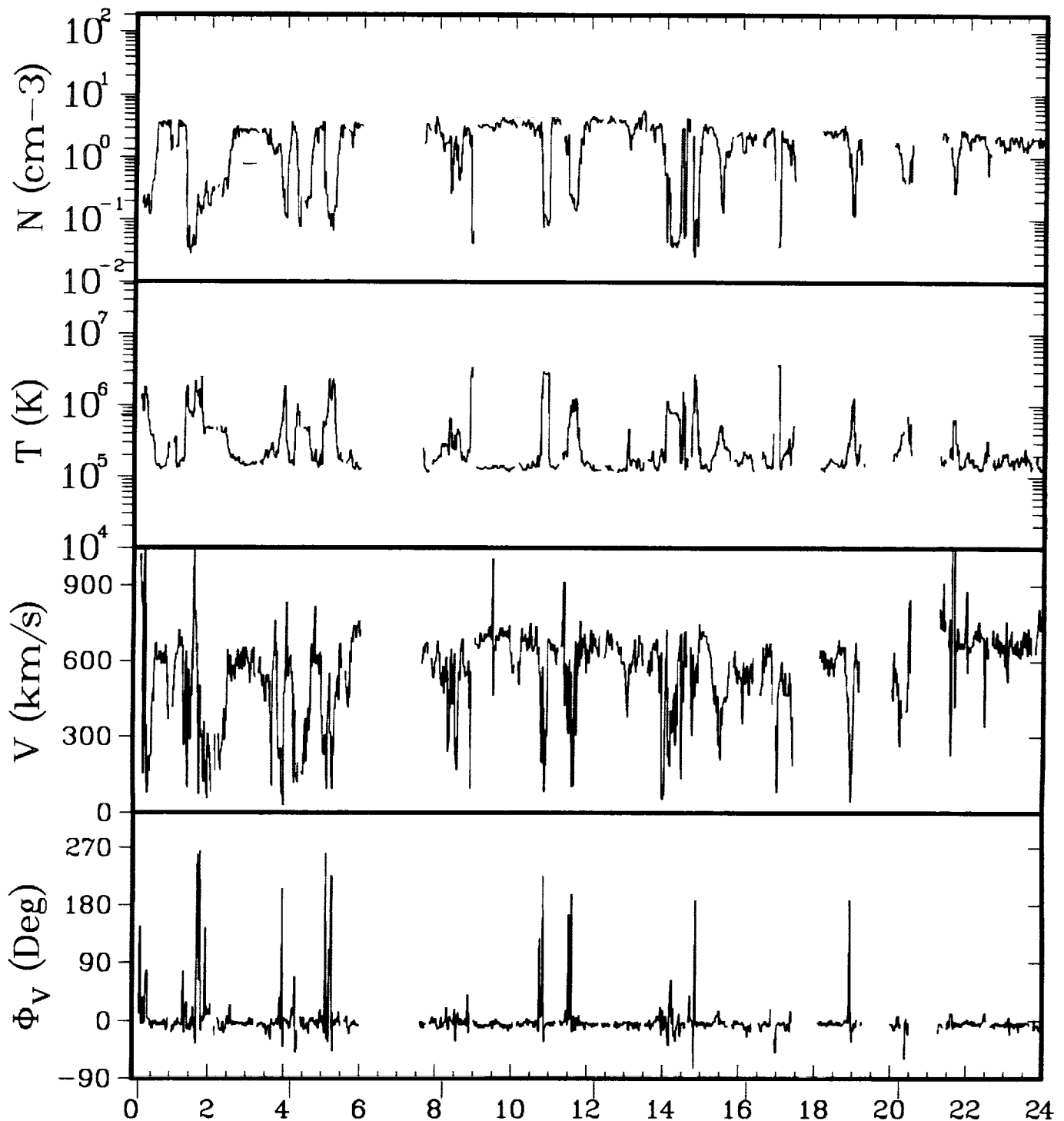

ISEE-3 ELECTRONS 01/18/83

GSEX	-196.3	-196.7	-197.1	-197.5	-198.0	-198.4
Y	-13.8	-13.6	-13.4	-13.2	-13.0	-12.8
Z	-1.4	-1.5	-1.6	-1.7	-1.8	-1.9
GSMY	-12.2	-12.9	-13.4	-13.2	-12.5	-11.2
Z	-6.7	-4.6	-1.8	-1.7	-4.0	-6.4

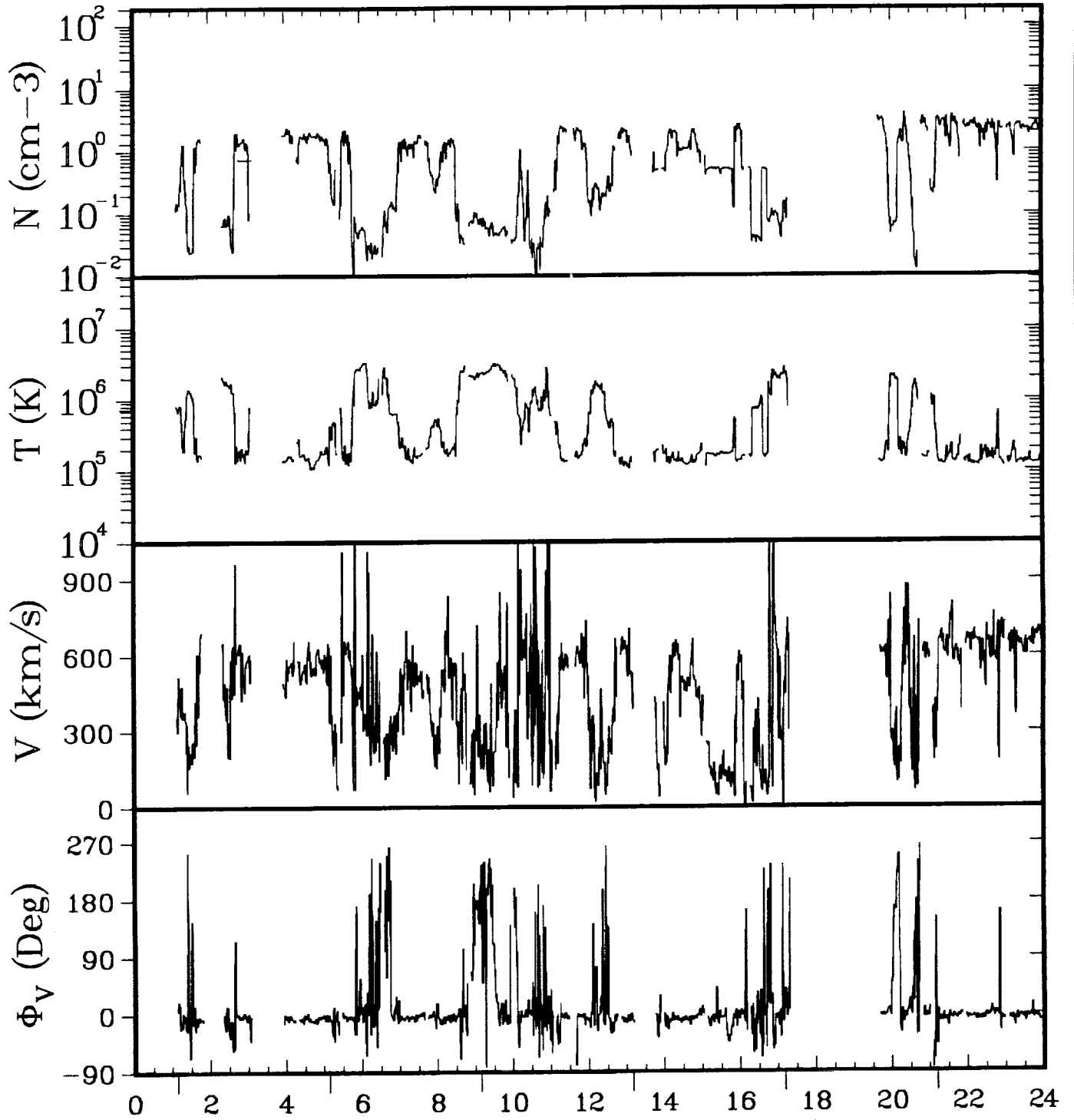

ISEE-3 ELECTRONS 01/19/83

GSEX	-198.9	-199.3	-199.7	-200.1	-200.5	-200.9
Y	-12.5	-12.3	-12.1	-11.9	-11.6	-11.4
Z	-2.0	-2.1	-2.2	-2.3	-2.4	-2.5
GSMY	-10.8	-11.7	-12.1	-11.8	-10.8	-9.5
Z	-6.6	-4.3	-2.2	-2.7	-5.0	-6.8

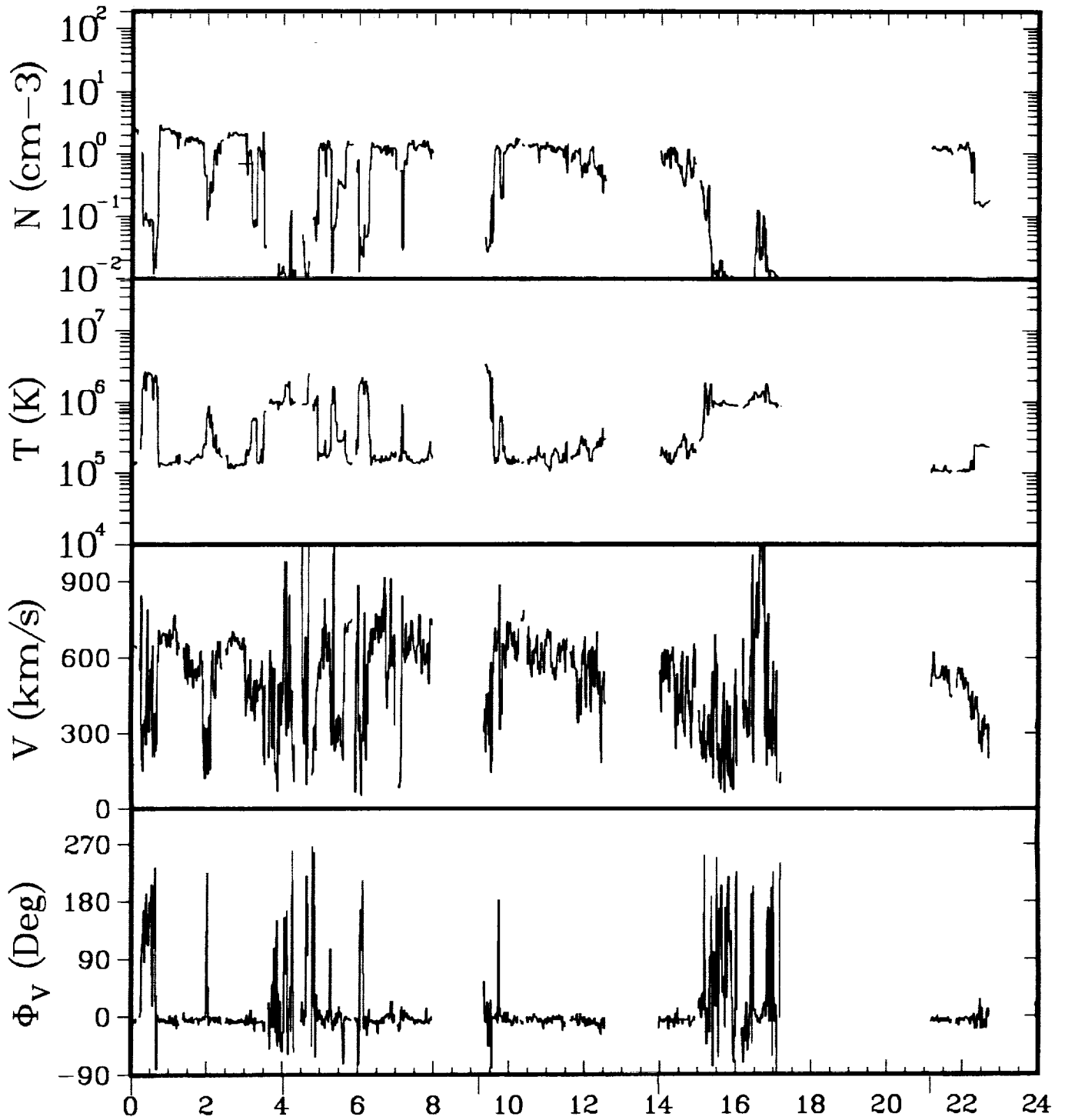

ISEE-3 ELECTRONS 01/20/83

GSEX	-201.2	-201.6	-202.1	-202.5	-203.2
Y	-11.2	-11.0	-10.7	-10.4	-10.0
Z	-2.6	-2.7	-2.8	-3.0	-3.2
GSMY	-9.2	-10.0	-10.7	-10.2	-7.9
Z	-7.0	-5.4	-2.9	-3.7	-6.9

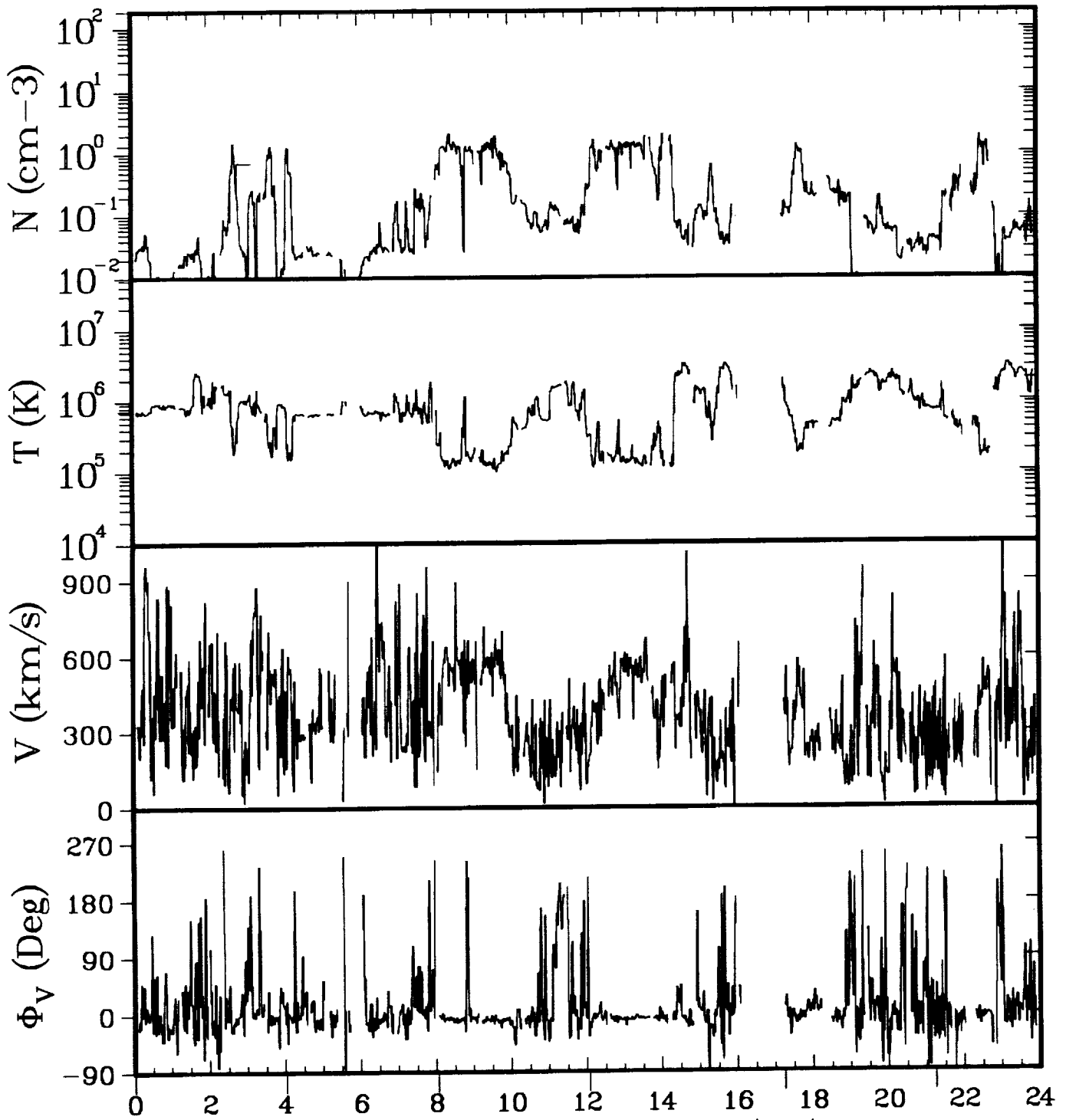

ISEE-3 ELECTRONS 01/21/83

GSEX	-203.4	-203.8	-204.2	-204.5	-205.0	-205.3
Y	-9.8	-9.6	-9.4	-9.1	-8.8	-8.6
Z	-3.2	-3.3	-3.4	-3.5	-3.7	-3.8
GSMY	-7.6	-8.4	-9.2	-9.1	-7.6	-6.3
Z	-7.0	-5.7	-3.8	-3.7	-5.7	-6.9

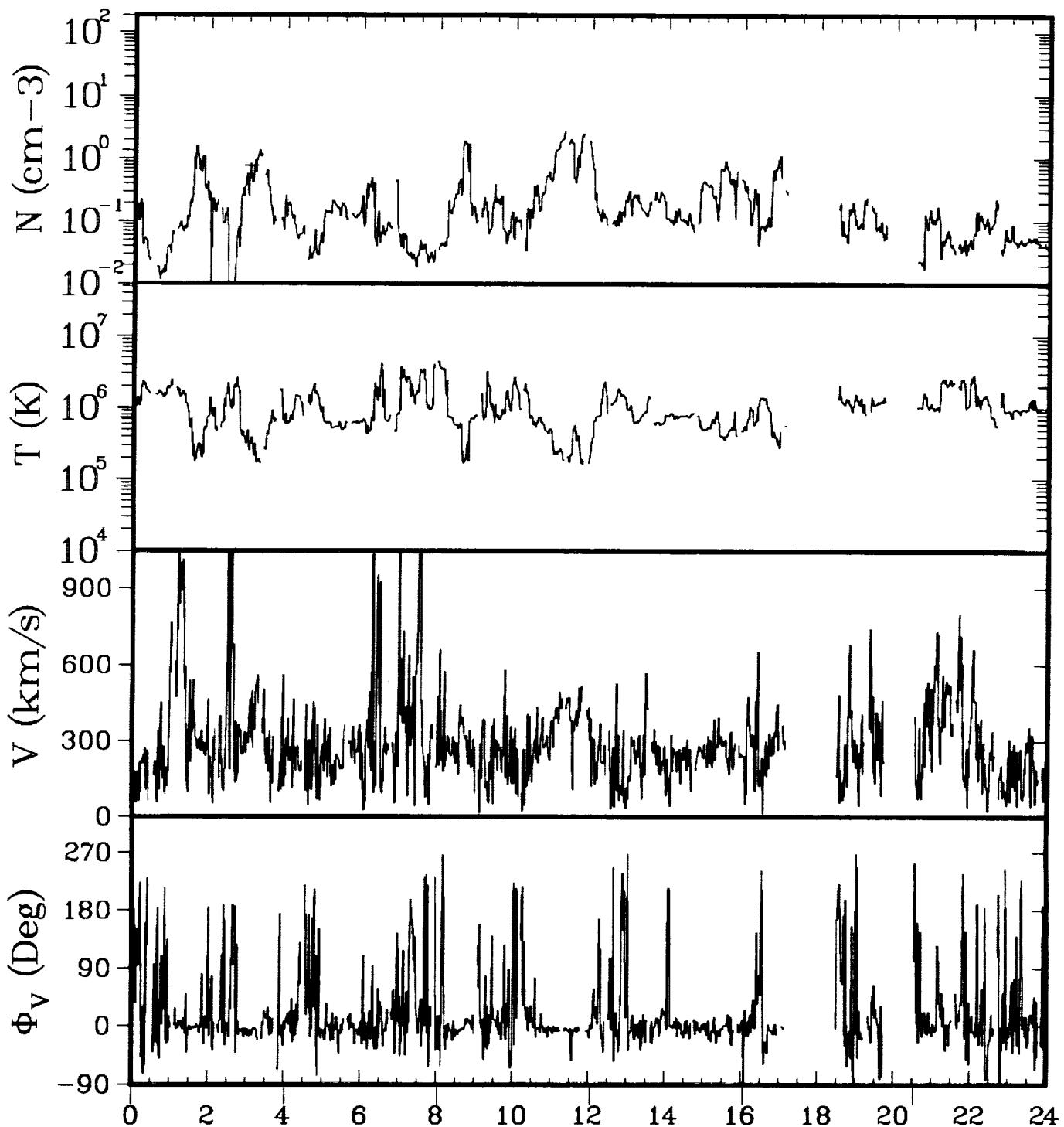

ISEE-3 ELECTRONS 01/22/83

GSEX	-205.6	-205.9	-206.3	-206.6	-206.9	-207.3
Y	-8.4	-8.1	-7.9	-7.6	-7.4	-7.1
Z	-3.8	-3.9	-4.0	-4.1	-4.2	-4.3
GSMY	-6.0	-6.8	-7.7	-7.5	-6.5	-4.8
Z	-7.0	-6.0	-4.4	-4.3	-5.5	-6.8

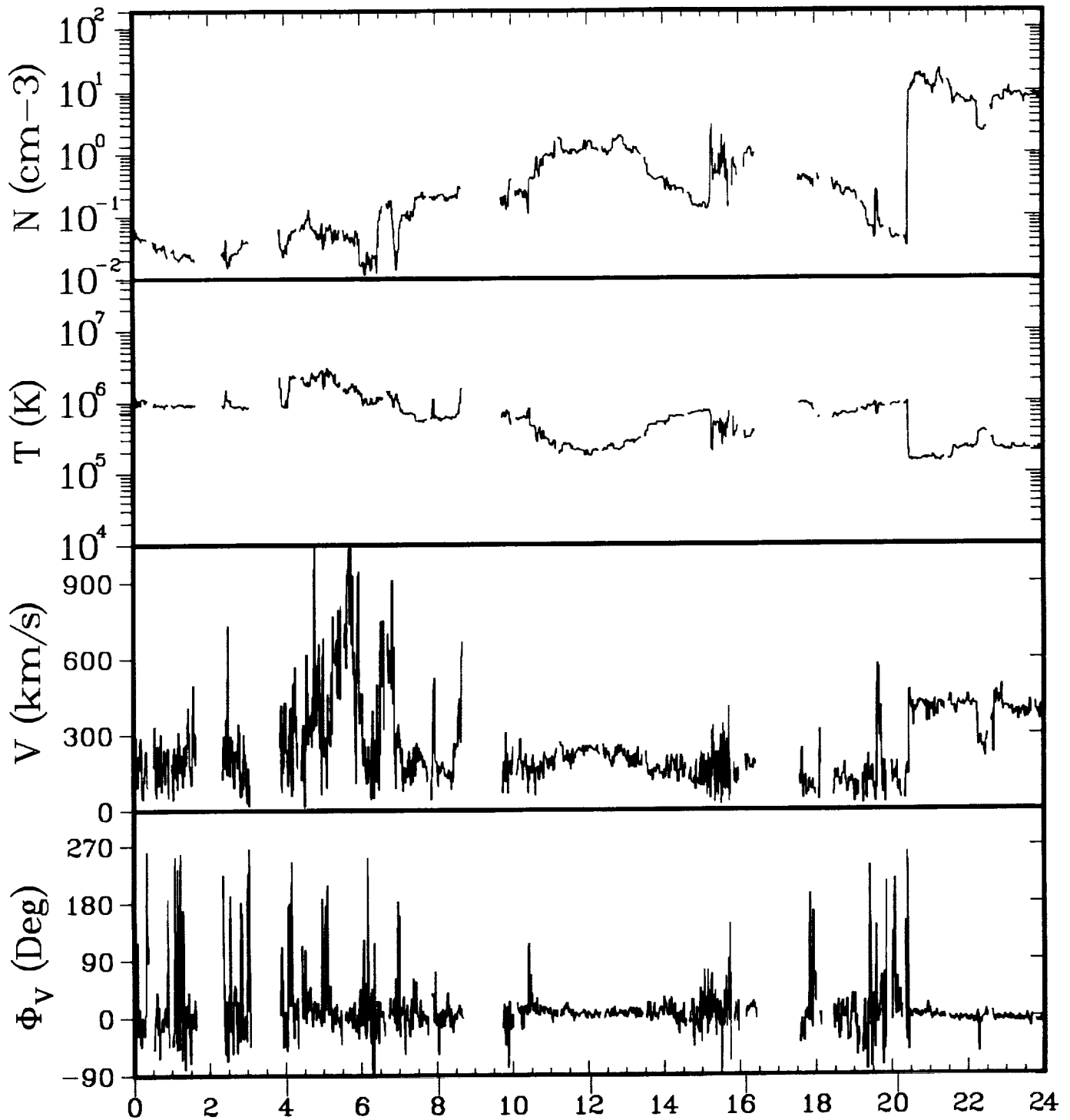

ISEE-3 ELECTRONS 01/23/83

GSEX	-207.6	-207.9	-208.2	-208.5	-208.8	-209.1
Y	-6.9	-6.6	-6.4	-6.1	-5.9	-5.6
Z	-4.4	-4.5	-4.6	-4.7	-4.8	-4.9
GSMY	-4.3	-5.1	-6.1	-6.0	-4.8	-3.3
Z	-6.9	-6.2	-5.0	-4.9	-5.9	-6.7

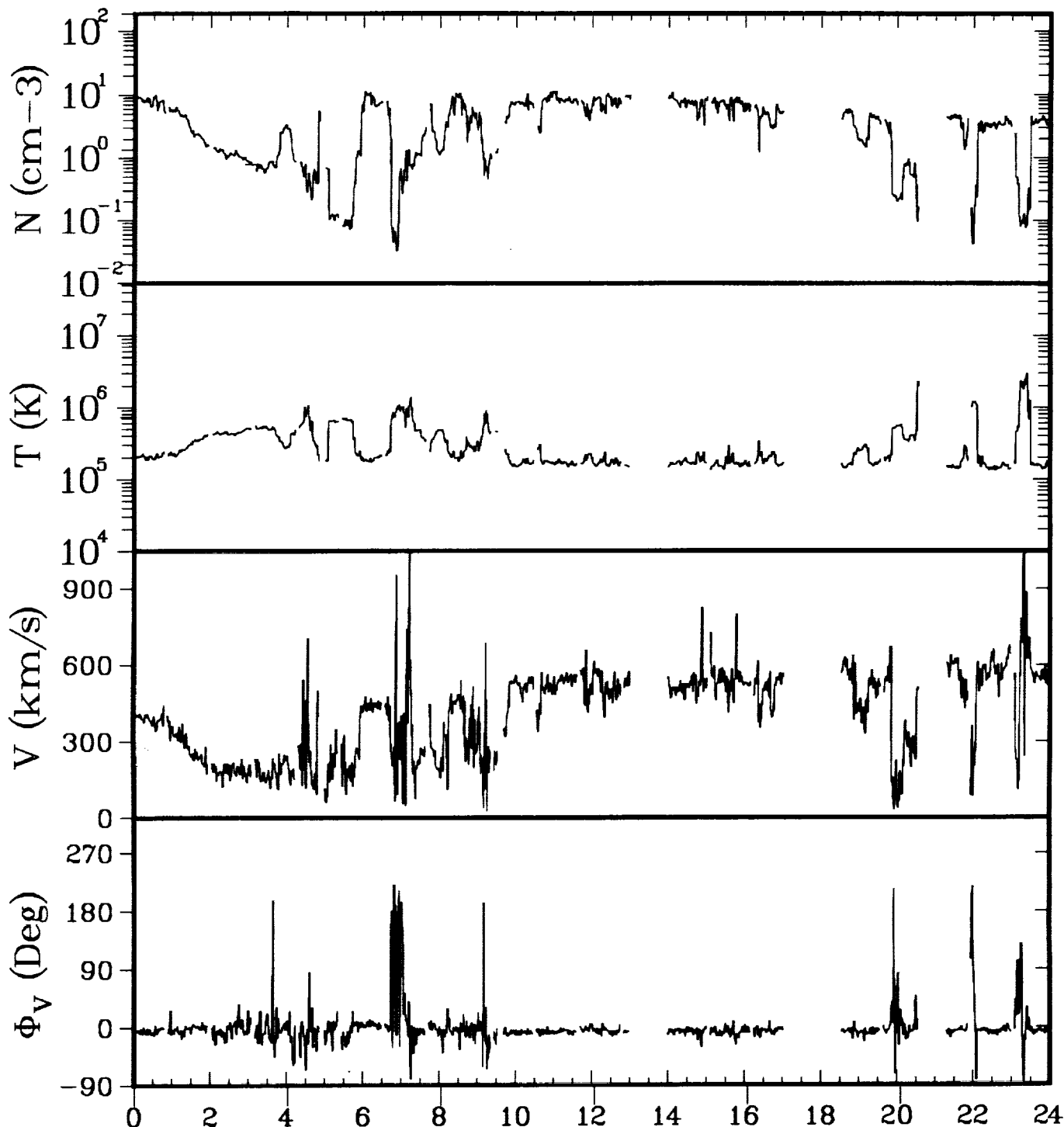

ISEE-3 ELECTRONS 01/24/83

GSEX	-209.4	-209.7	-210.0	-210.3	-210.6	-210.9
Y	-5.3	-5.1	-4.8	-4.6	-4.3	-4.0
Z	-5.0	-5.1	-5.2	-5.3	-5.4	-5.5
GSMY	-2.6	-3.4	-4.5	-4.4	-3.1	-1.6
Z	-6.8	-6.3	-5.5	-5.5	-6.2	-6.6

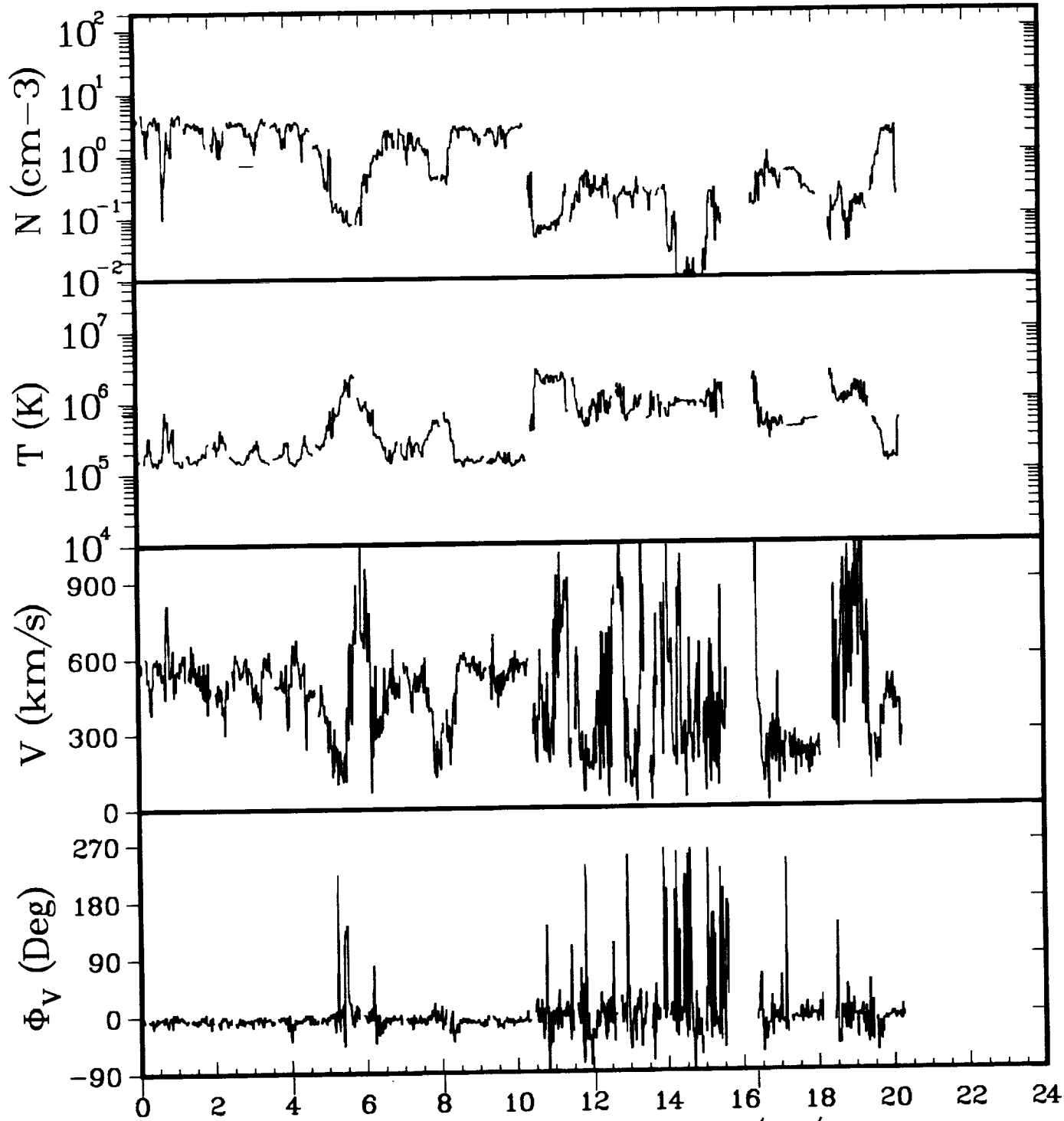

ISEE-3 ELECTRONS 01/25/83

GSEX	-211.2	-211.4	-211.7	-212.0	-212.2
Y	-3.8	-3.5	-3.2	-3.0	-2.7
Z	-5.6	-5.7	-5.8	-5.9	-6.0
GSMY	-0.9	-1.7	-2.8	-2.7	-1.3
Z	-6.7	-6.5	-6.0	-6.0	-6.4

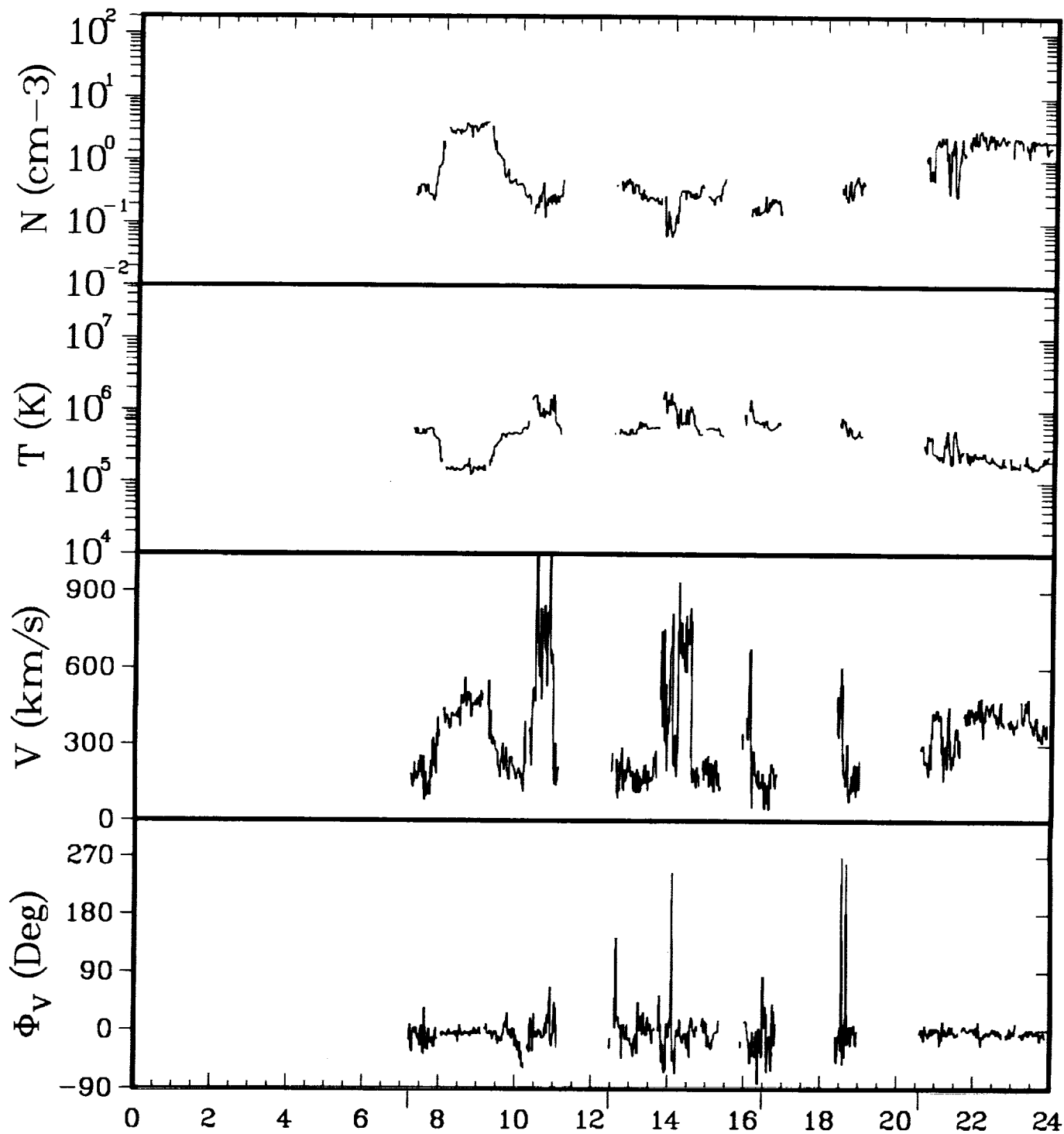

ISEE-3 ELECTRONS 01/26/83

GSEX	-213.2	-213.5	-213.7	-214.0
Y	-1.7	-1.3	-1.1	-0.8
Z	-6.3	-6.5	-6.6	-6.6
GSMY	-1.0	-1.0	0.5	2.0
Z	-6.5	-6.5	-6.6	-6.4

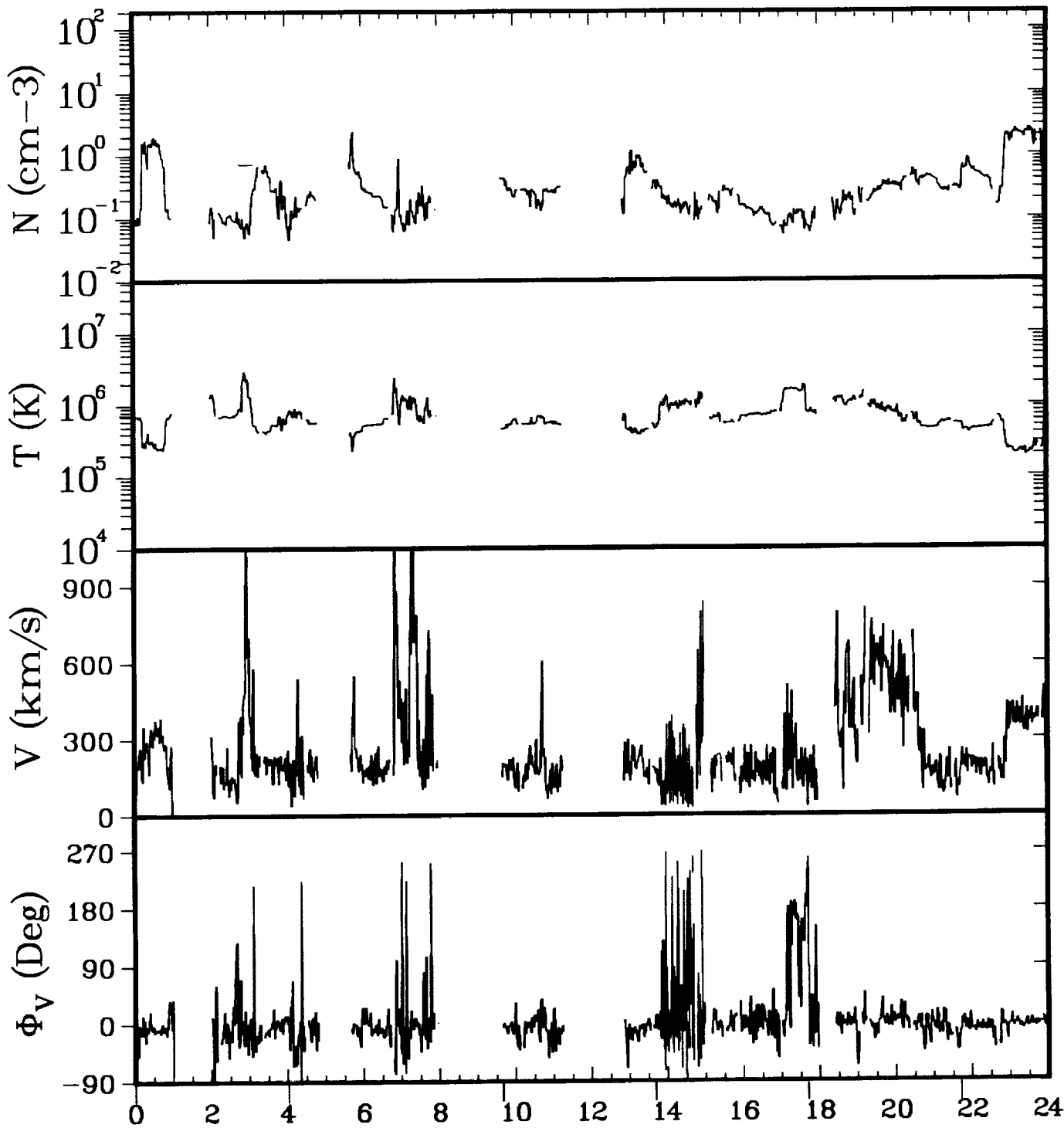

ISEE-3 ELECTRONS 01/27/83

GSEX	-214.2	-214.4	-214.7	-214.9	-215.1	-215.3
Y	-0.5	-0.3	0.1	0.4	0.7	1.0
Z	-6.7	-6.8	-6.9	-7.0	-7.1	-7.2
GSMY	2.5	1.8	0.4	1.1	2.8	4.1
Z	-6.3	-6.6	-6.9	-7.0	-6.6	-6.0

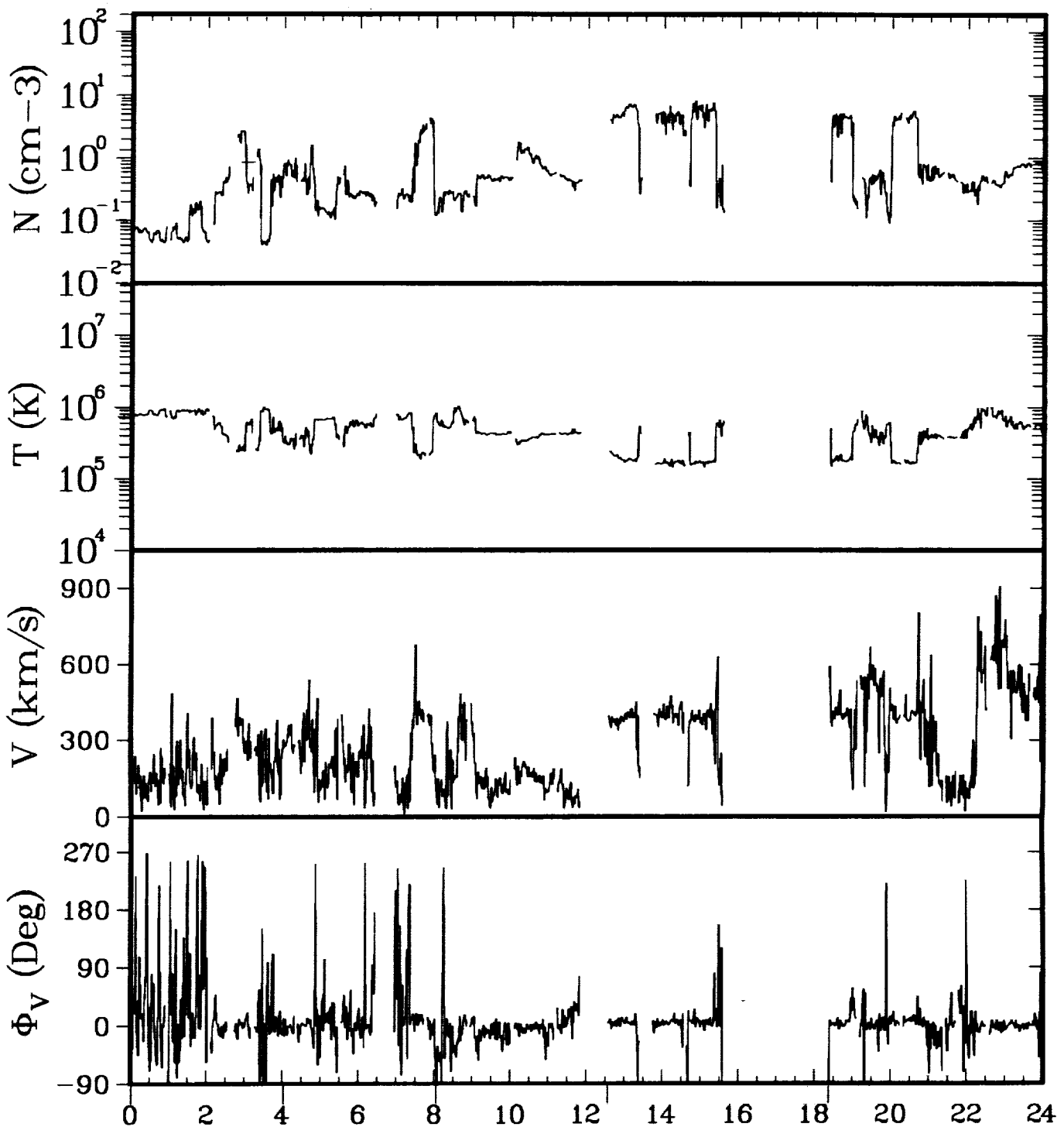

ISEE-3 ELECTRONS 01/28/83

GSEX	-215.4	-215.6	-215.8	-216.0	-216.3
Y	1.1	1.4	1.7	2.0	2.4
Z	-7.3	-7.4	-7.5	-7.6	-7.7
GSMY	4.3	3.6	2.3	2.5	4.9
Z	-6.0	-6.6	-7.3	-7.4	-6.4

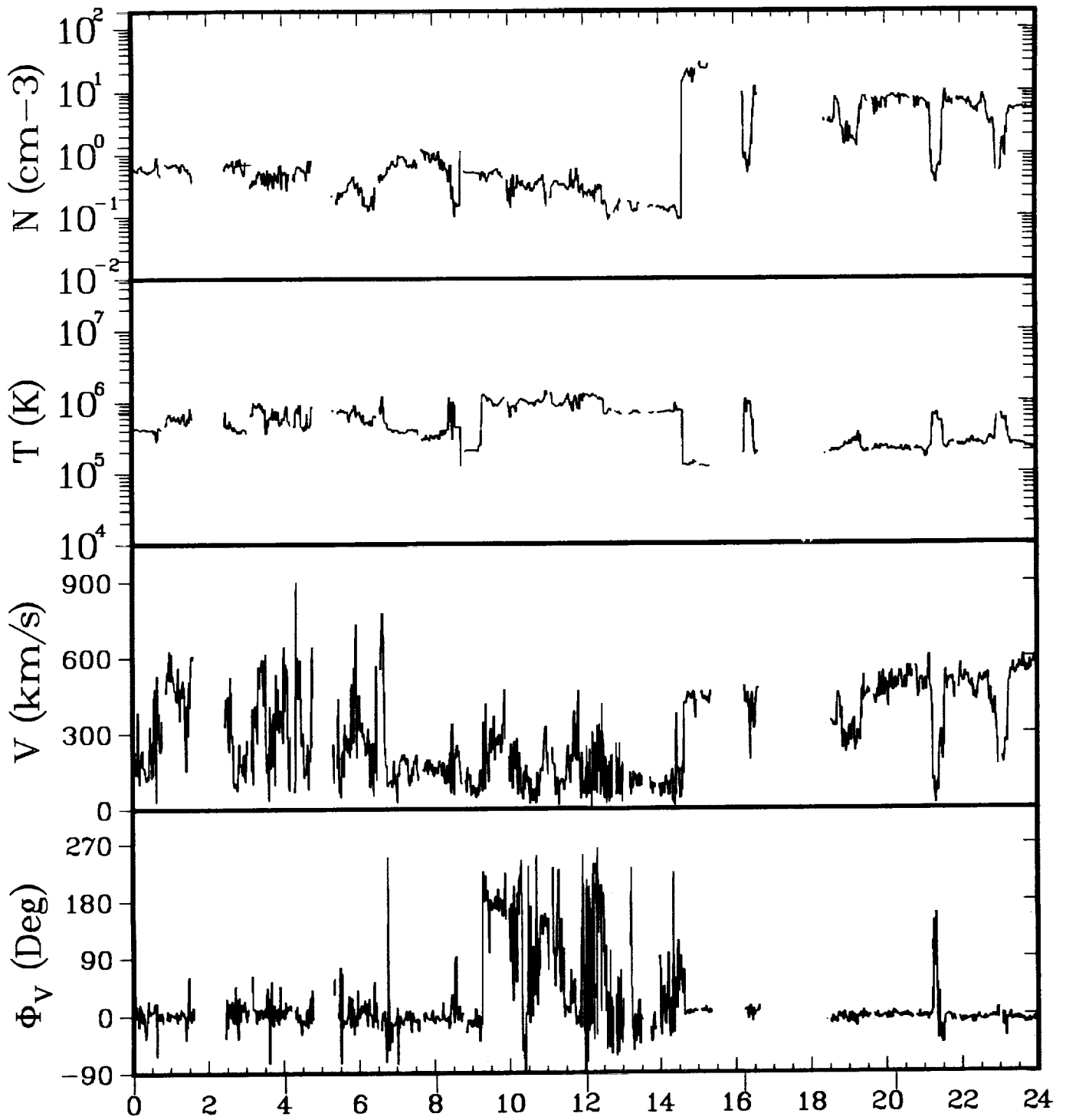

ISEE-3 ELECTRONS 01/29/83

GSEX	-216.5	-216.7	-216.9	-217.0	-217.2	-217.3
Y	2.8	3.1	3.4	3.7	4.0	4.2
Z	-7.8	-7.9	-8.0	-8.1	-8.2	-8.3
GSMY	6.1	5.4	4.1	4.2	5.8	7.3
Z	-5.7	-6.6	-7.6	-7.8	-7.0	-5.7

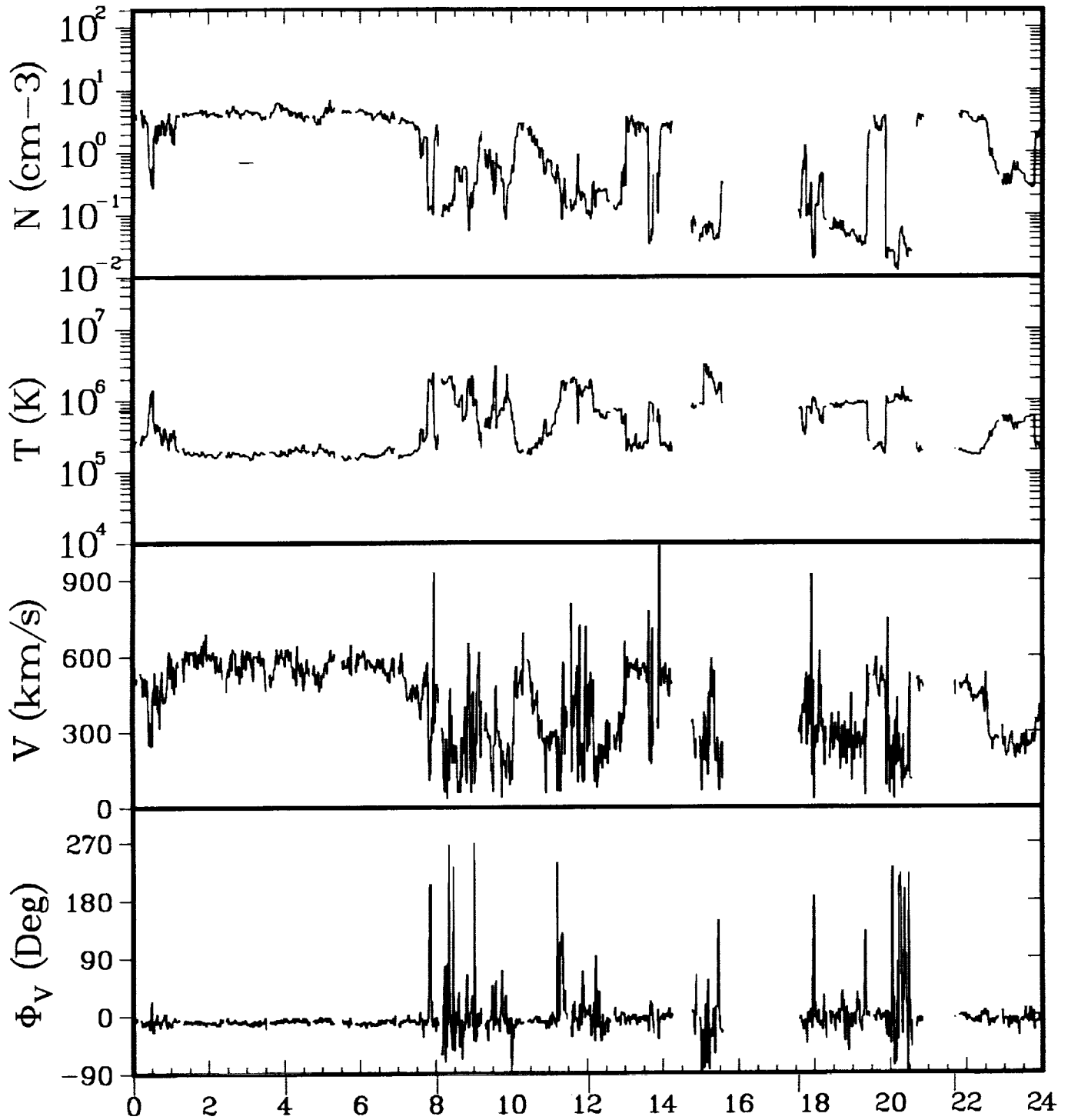

ISEE-3 ELECTRONS 01/30/83

GSEX	-217.5	-217.6	-217.8	-217.9	-218.1	-218.2
Y	4.5	4.8	5.1	5.4	5.8	6.1
Z	-8.3	-8.4	-8.5	-8.6	-8.7	-8.8
GSMY	7.9	7.2	5.9	6.0	8.2	9.5
Z	-5.3	-6.5	-8.0	-8.2	-6.5	-5.0

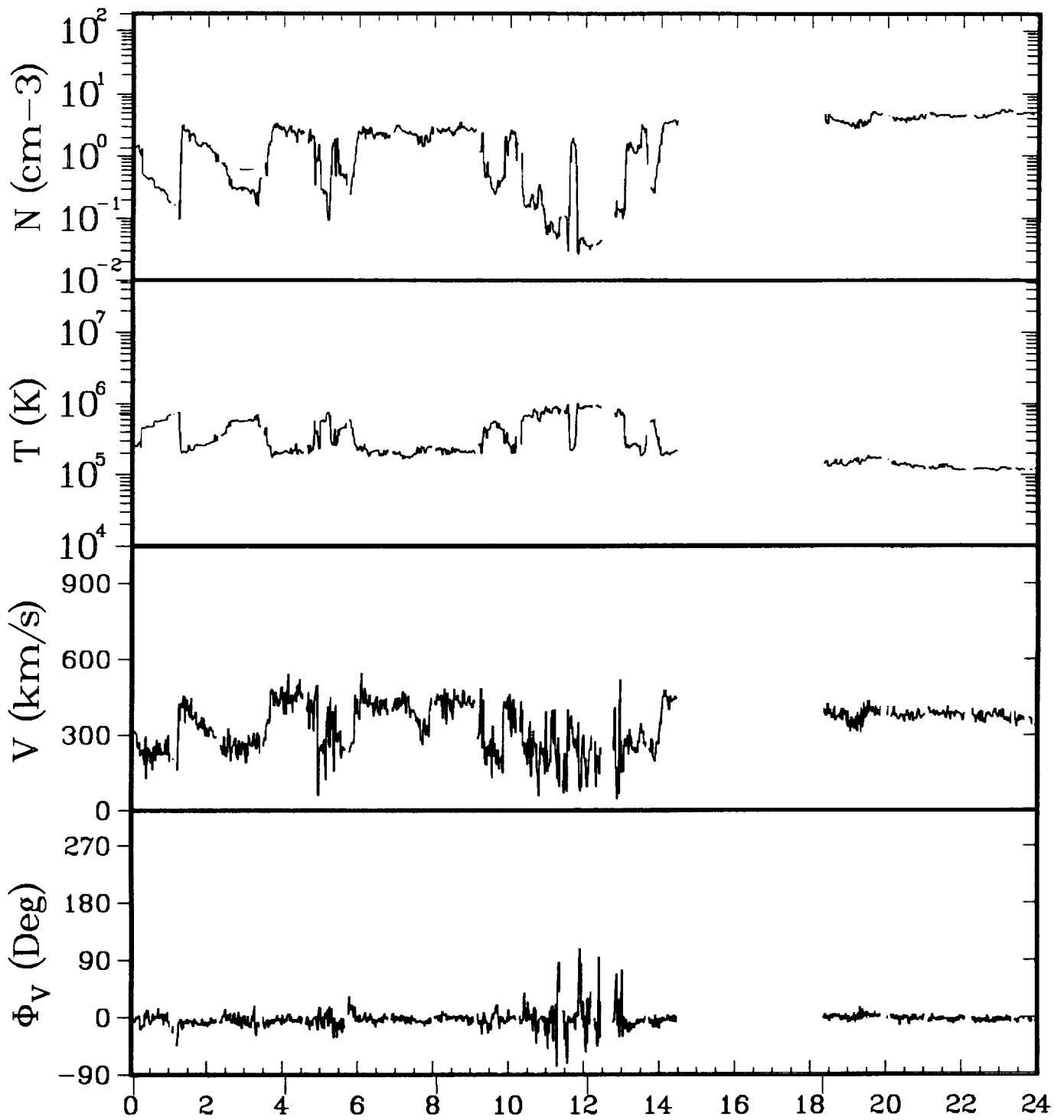

ISEE-3 ELECTRONS 01/31/83

GSEX	-218.3	-218.4	-218.5	-218.6	-218.8
Y	6.3	6.6	6.9	7.2	7.6
Z	-8.9	-9.0	-9.0	-9.1	-9.3
GSMY	9.7	9.1	7.8	7.9	10.4
Z	-4.9	-6.4	-8.3	-8.5	-6.0

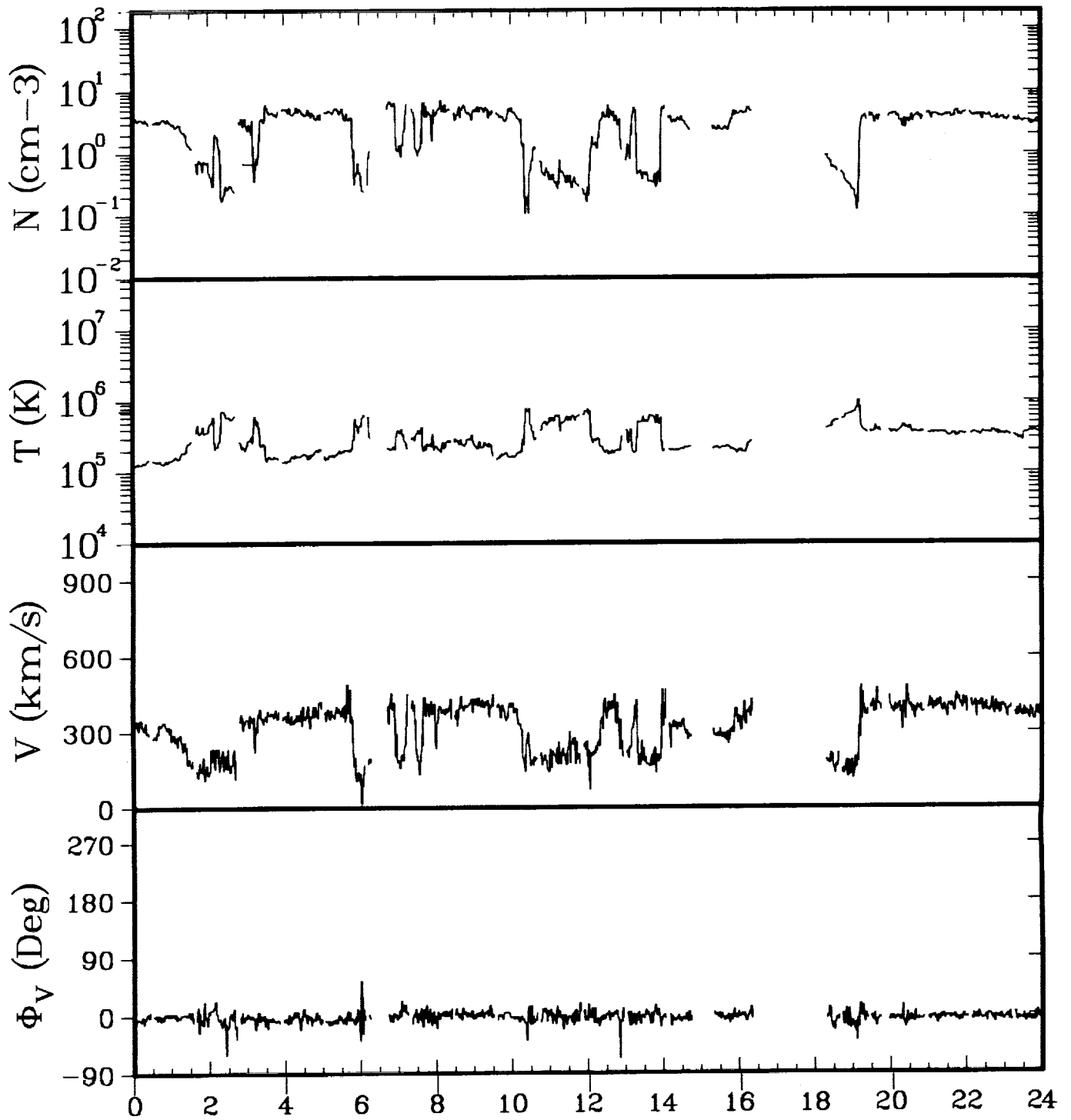

ISEE-3 ELECTRONS 02/01/83

GSEX	-219.0	-219.1	-219.1	-219.2	-219.3	-219.4
Y	8.1	8.4	8.7	9.0	9.3	9.6
Z	-9.4	-9.5	-9.5	-9.6	-9.7	-9.8
GSMY	11.5	11.0	9.7	9.7	11.3	12.9
Z	-4.5	-6.2	-8.5	-8.9	-7.2	-4.8

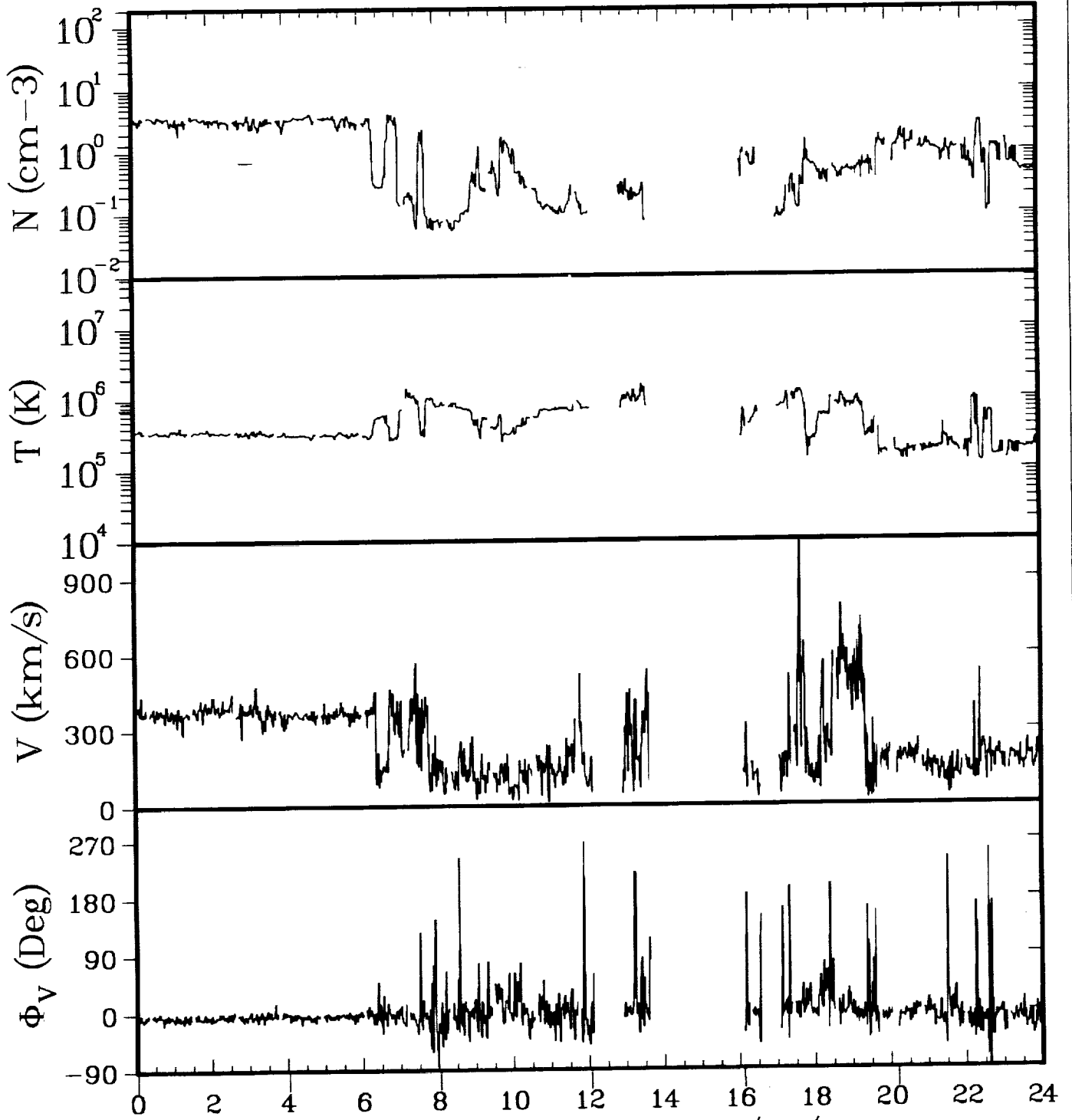

ISEE-3 ELECTRONS 02/02/83

GSEX	-219.5	-219.6	-219.6	-219.7	-219.8	-219.8
Y	9.9	10.2	10.5	10.8	11.2	11.5
Z	-9.9	-10.0	-10.0	-10.1	-10.2	-10.3
GSMY	13.4	12.9	11.6	11.7	13.3	14.8
Z	-4.0	-6.1	-8.7	-9.1	-7.1	-4.3

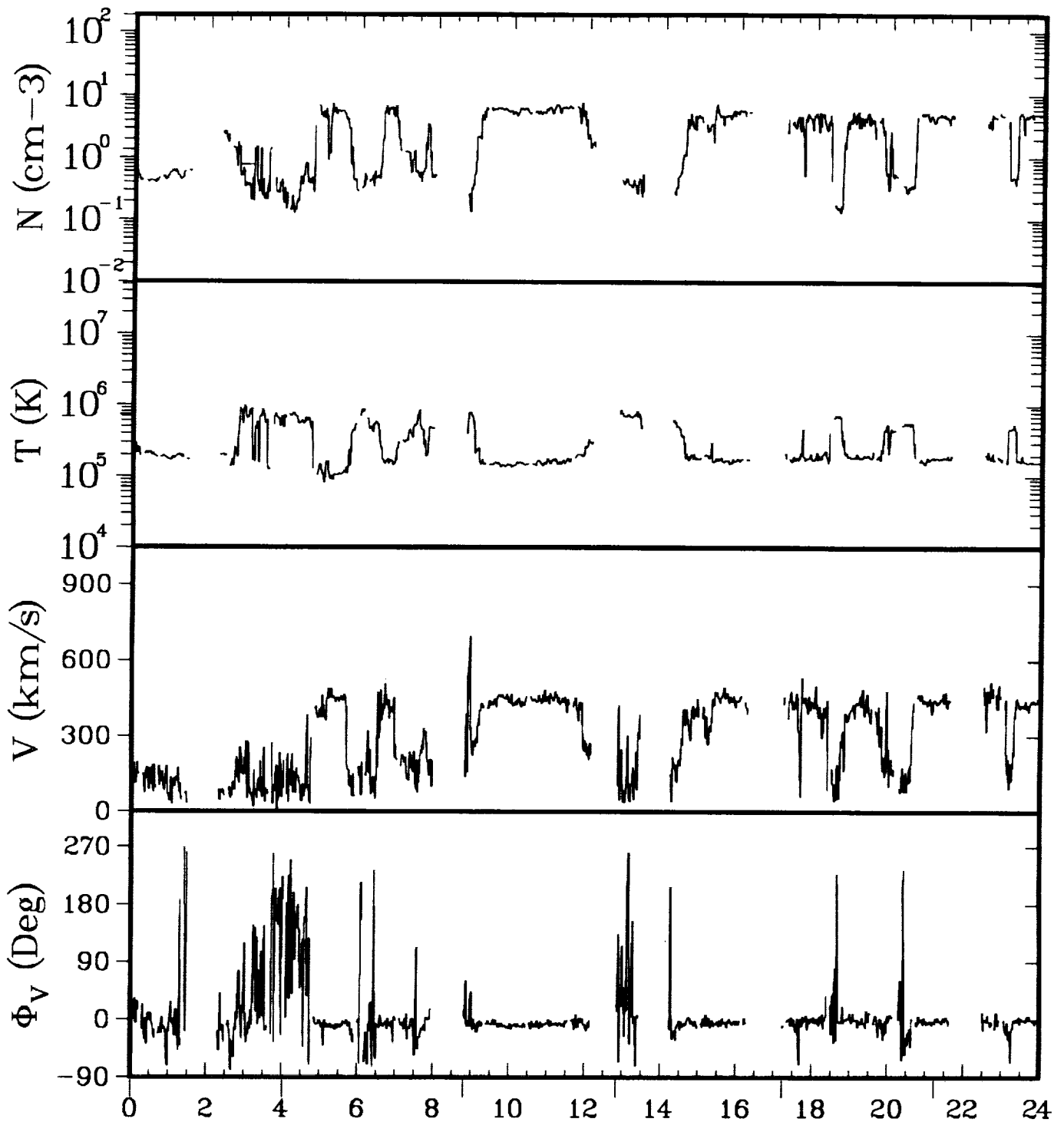

ISEE-3 ELECTRONS 02/03/83

GSEX	-219.9	-219.9	-220.0	-220.0	-220.1	-220.1
Y	11.8	12.1	12.5	12.8	13.1	13.5
Z	-10.4	-10.5	-10.6	-10.6	-10.7	-10.8
GSMY	15.3	14.9	13.5	13.9	15.8	16.9
Z	-3.5	-5.8	-9.2	-9.1	-6.1	-3.3

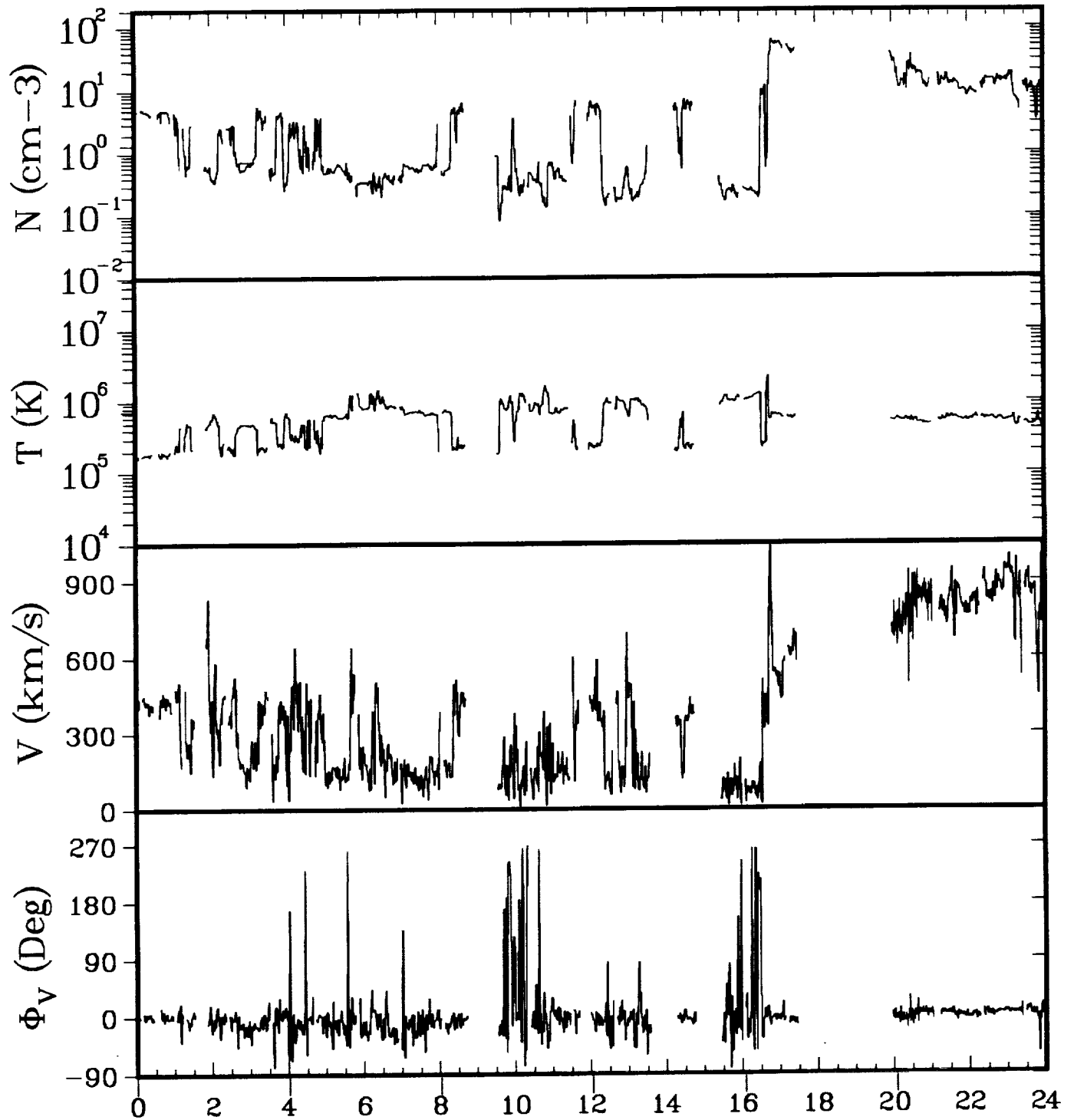

ISEE-3 ELECTRONS 02/04/83

GSEX	-220.2	-220.2	-220.2	-220.3	-220.3	-220.3
Y	13.7	14.0	14.3	14.6	15.0	15.3
Z	-10.9	-10.9	-11.0	-11.1	-11.2	-11.2
GSMY	17.2	16.9	15.6	15.7	17.3	18.7
Z	-2.9	-5.5	-9.1	-9.6	-7.0	-3.4

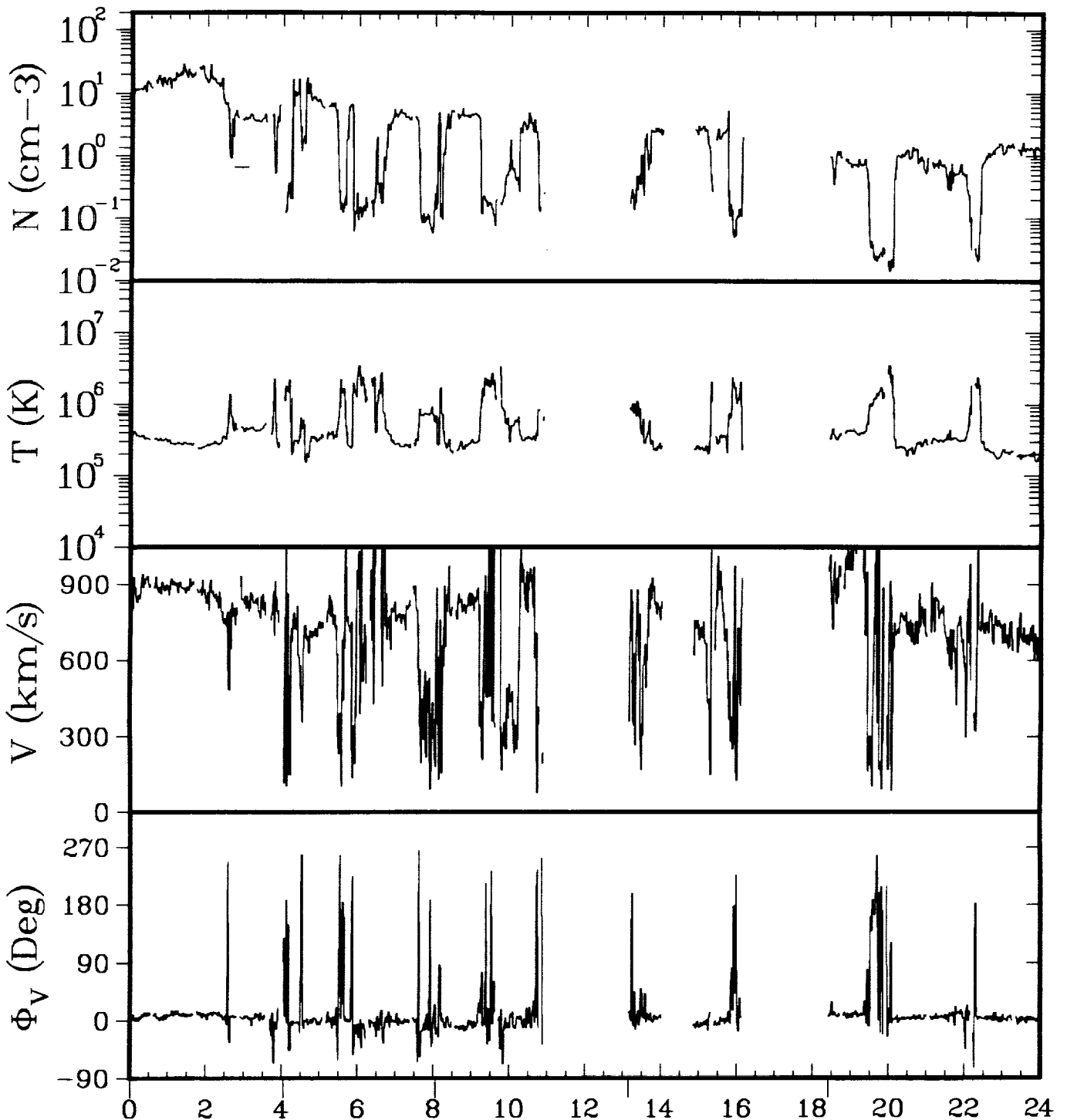

ISEE-3 ELECTRONS 02/05/83

GSEX	-220.3	-220.4	-220.4	-220.4	-220.4
Y	15.6	15.9	16.3	16.7	17.1
Z	-11.3	-11.4	-11.5	-11.6	-11.7
GSMY	19.1	18.9	17.7	18.1	20.2
Z	-2.3	-5.3	-9.2	-9.3	-4.4

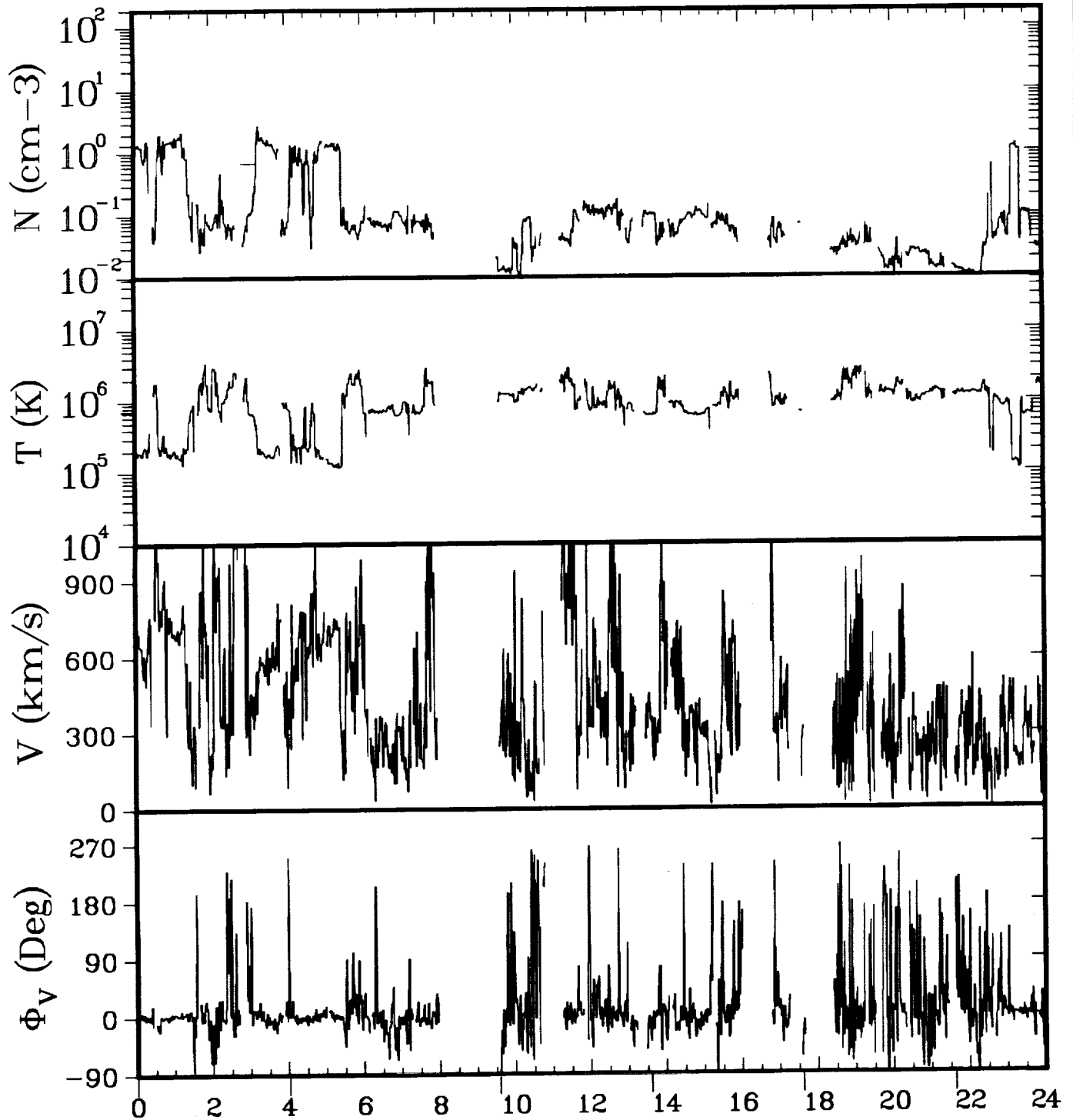

ISEE-3 ELECTRONS 02/06/83

GSEX	-220.4	-220.4	-220.4	-220.4	-220.4	-220.4
Y	17.6	17.9	18.4	18.7	19.0	19.3
Z	-11.8	-11.9	-12.0	-12.0	-12.1	-12.2
GSMY	21.1	20.9	19.5	20.3	22.0	22.8
Z	-1.6	-4.9	-10.1	-9.0	-4.8	-1.2

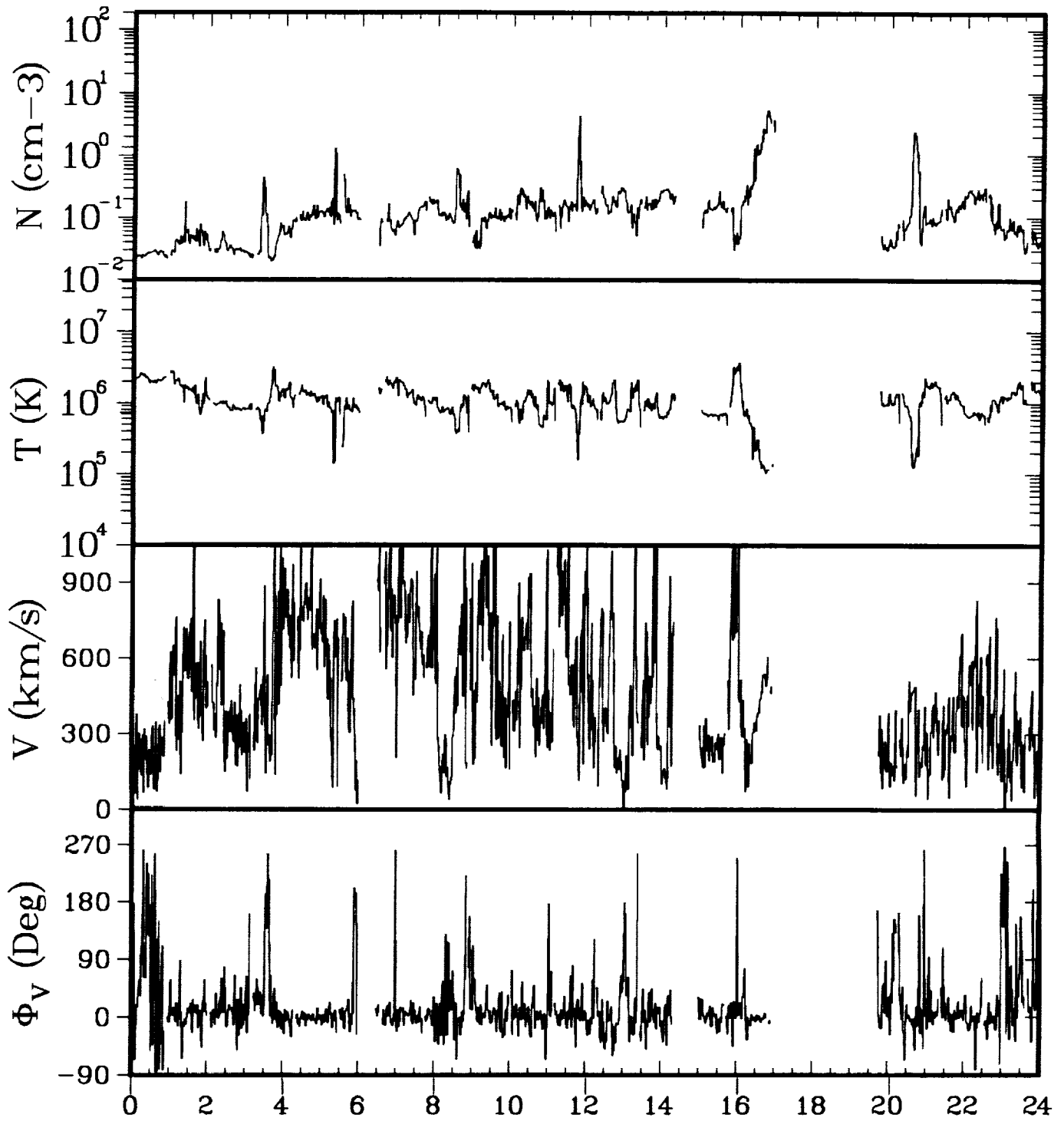

ISEE-3 ELECTRONS 02/07/83

GSEX	-220.4	-220.4	-220.4	-220.3	-220.3	-220.3
Y	19.5	19.9	20.2	20.5	20.9	21.2
Z	-12.2	-12.3	-12.4	-12.4	-12.5	-12.6
GSMY	23.0	22.9	21.8	21.8	23.5	24.6
Z	-1.0	-4.5	-9.3	-10.1	-6.5	-1.6

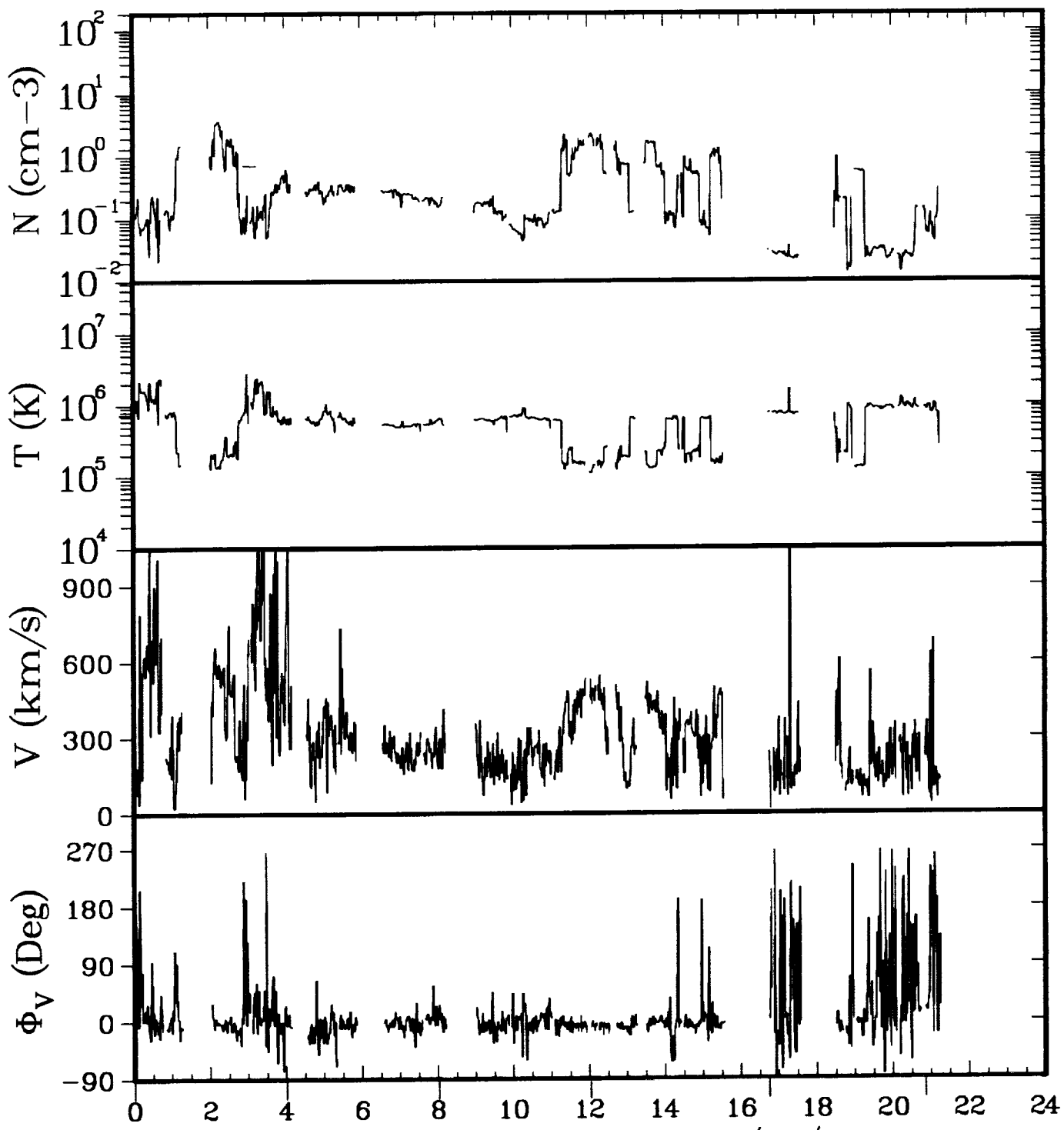

ISEE-3 ELECTRONS 02/08/83

GSEX	-220.3	-220.2	-220.2	-220.2	-220.1	-220.1
Y	21.5	21.9	22.2	22.5	22.9	23.2
Z	-12.6	-12.7	-12.8	-12.9	-12.9	-13.0
GSMY	25.0	24.9	23.9	23.9	25.8	26.6
Z	-0.2	-4.1	-9.3	-10.1	-5.2	-0.3

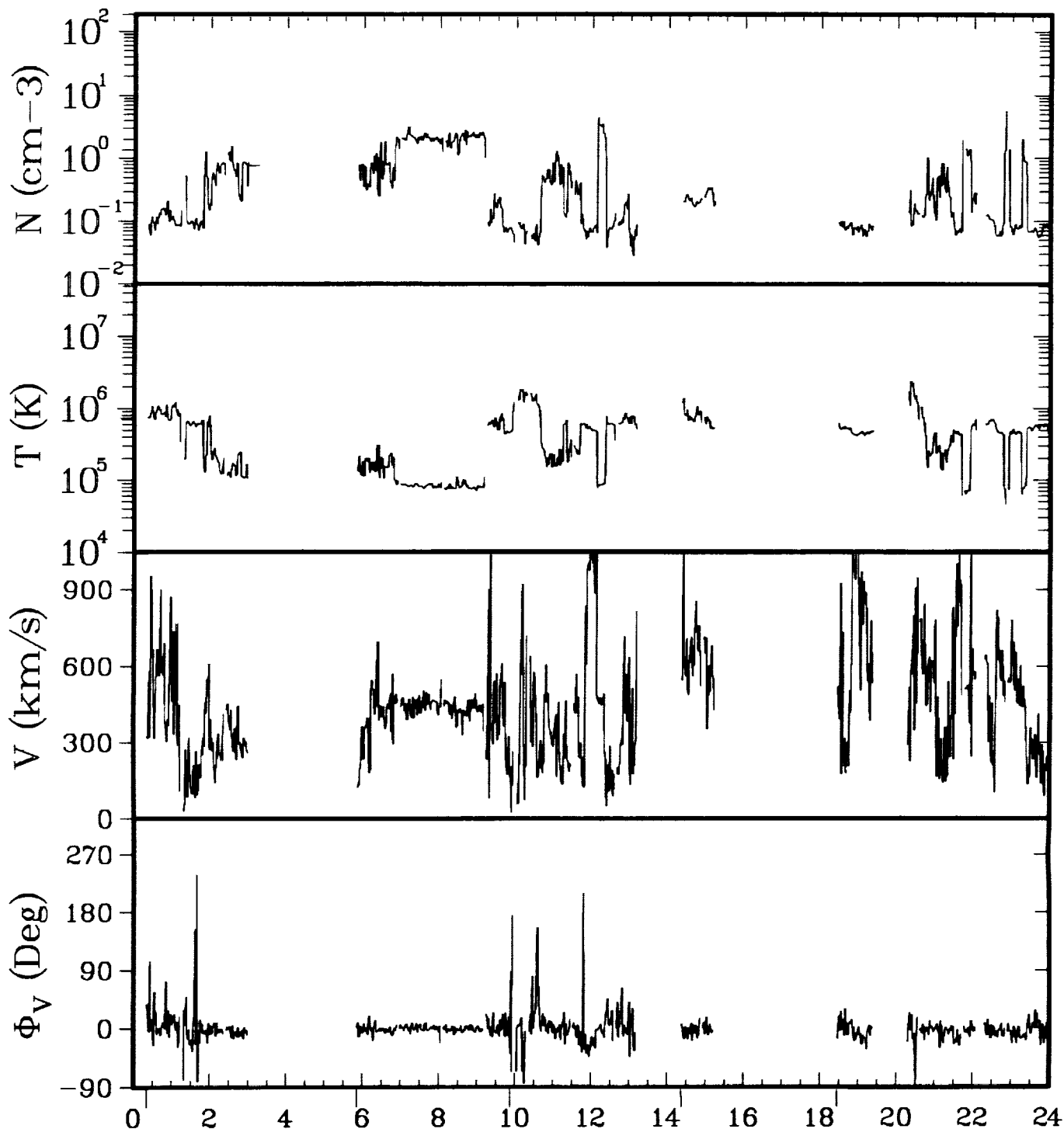

ISEE-3 ELECTRONS 02/09/83

GSEX	-220.1	-220.0	-220.0	-219.9	-219.9
Y	23.5	24.0	24.3	24.7	25.0
Z	-13.0	-13.0	-13.0	-13.0	-13.0
GSMY	26.9	26.5	25.6	26.7	28.1
Z	0.4	-6.4	-10.2	-7.9	-2.0

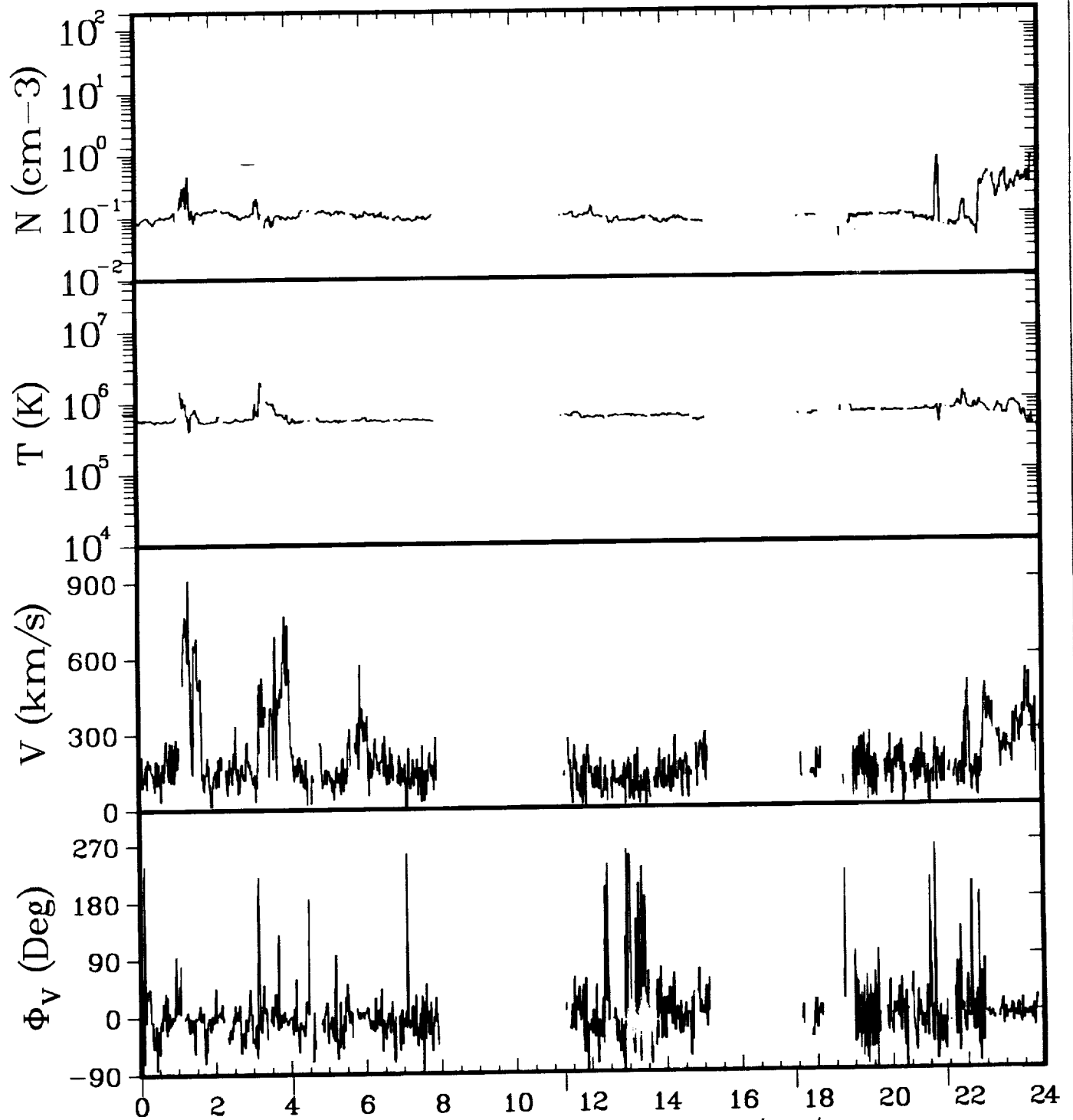

ISEE-3 ELECTRONS 02/10/83

GSEX	-219.8	-219.8	-219.7	-219.6	-219.5
Y	25.5	25.8	26.4	26.9	27.2
Z	-13.0	-12.9	-12.9	-12.9	-12.9
GSMY	28.5	28.7	27.7	29.7	30.0
Z	1.7	-2.7	-9.8	-2.7	2.4

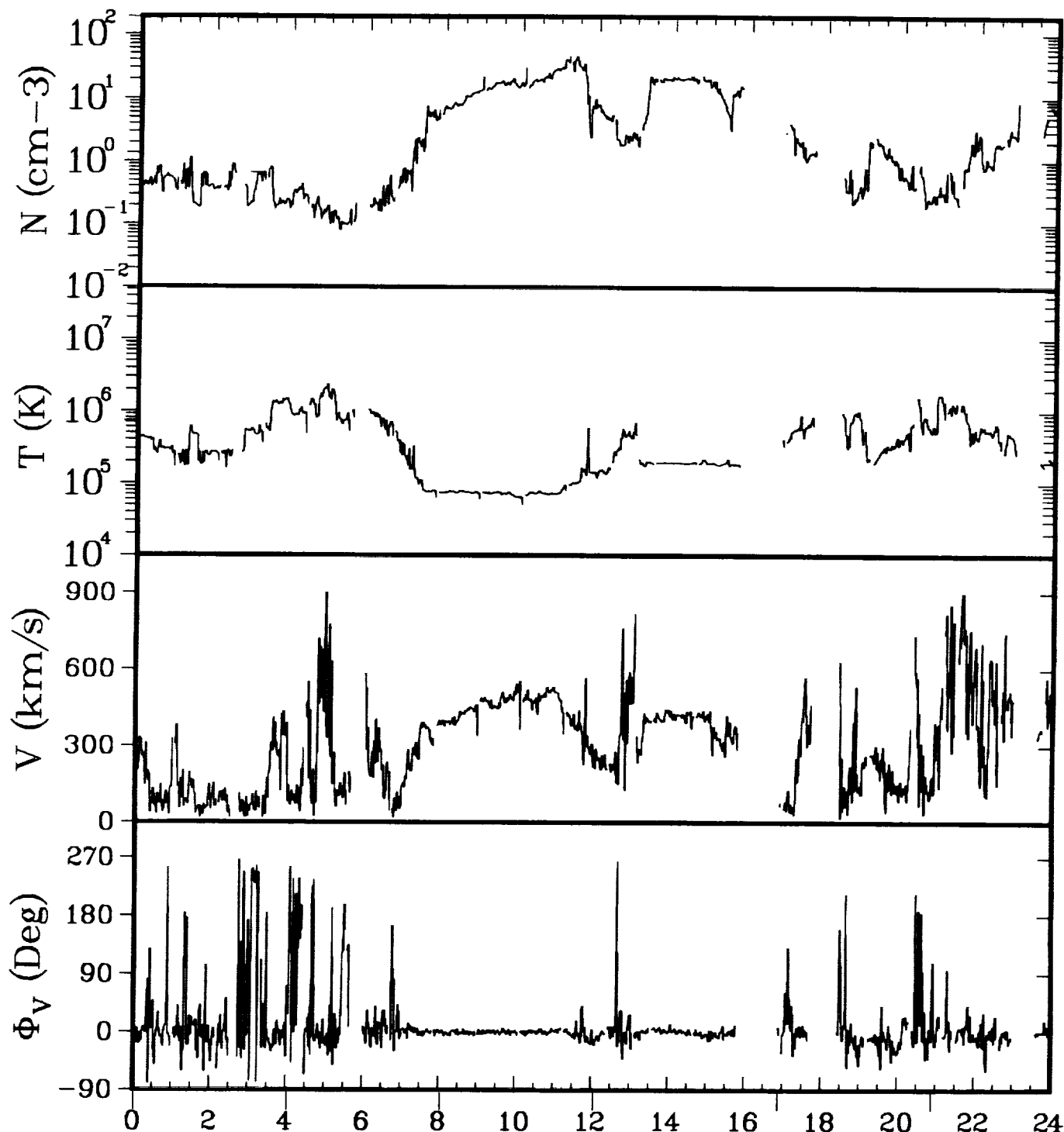

ISEE-3 ELECTRONS 02/11/83

GSEX	-219.5	-219.4	-219.3	-219.3	-219.2	-219.1
Y	27.4	27.7	28.1	28.4	28.8	29.1
Z	-12.9	-12.8	-12.8	-12.8	-12.8	-12.8
GSMY	30.1	30.5	29.8	29.8	31.4	31.6
Z	2.9	-1.8	-8.1	-9.0	-2.7	3.2

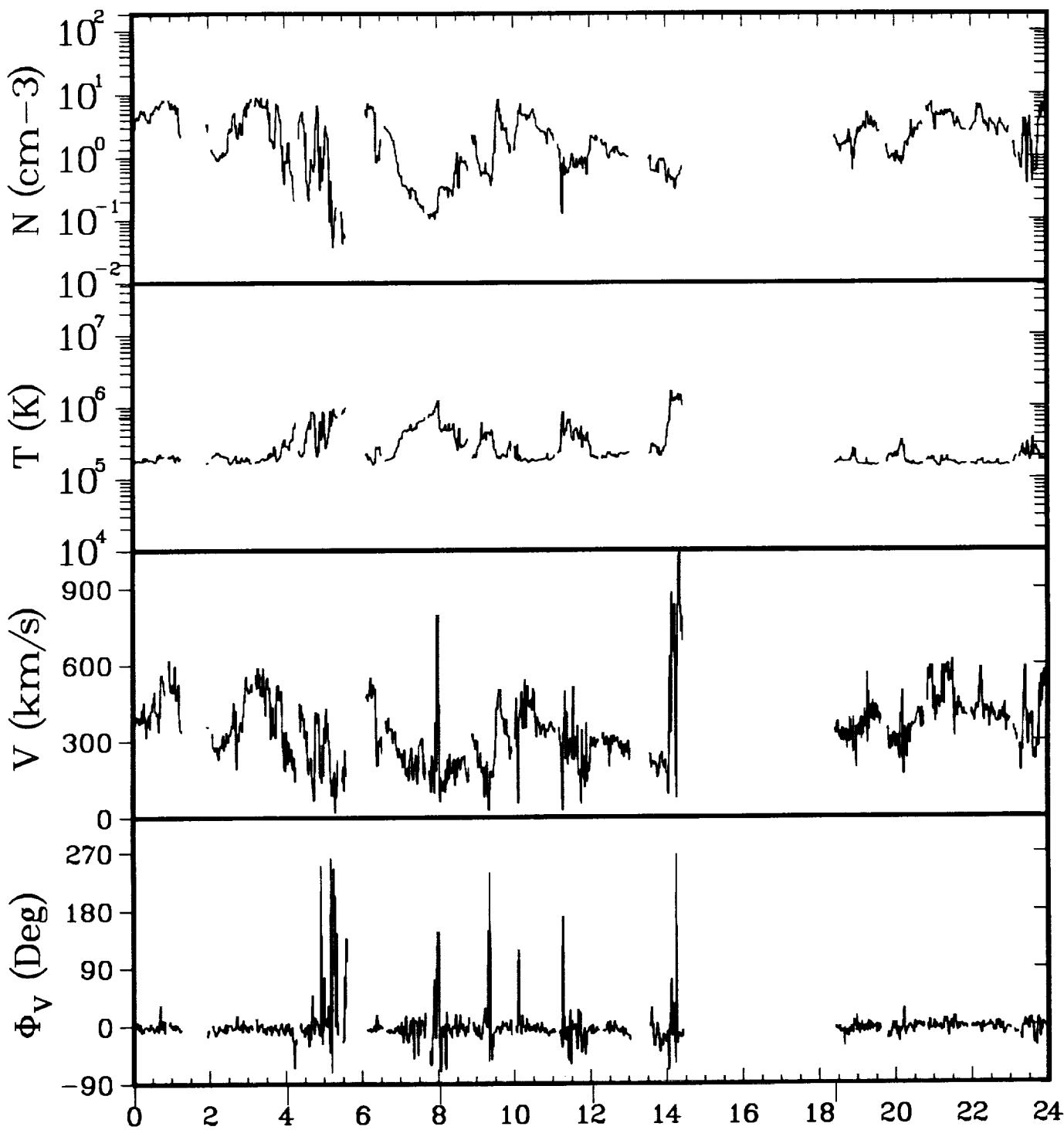

ISEE-3 ELECTRONS 02/12/83

GSEX	-219.1	-219.0	-218.9	-218.8	-218.7
Y	29.3	29.7	30.0	30.3	30.8
Z	-12.8	-12.7	-12.7	-12.7	-12.7
GSMY	31.7	32.3	31.7	31.7	33.3
Z	4.1	-0.8	-7.5	-8.5	0.9

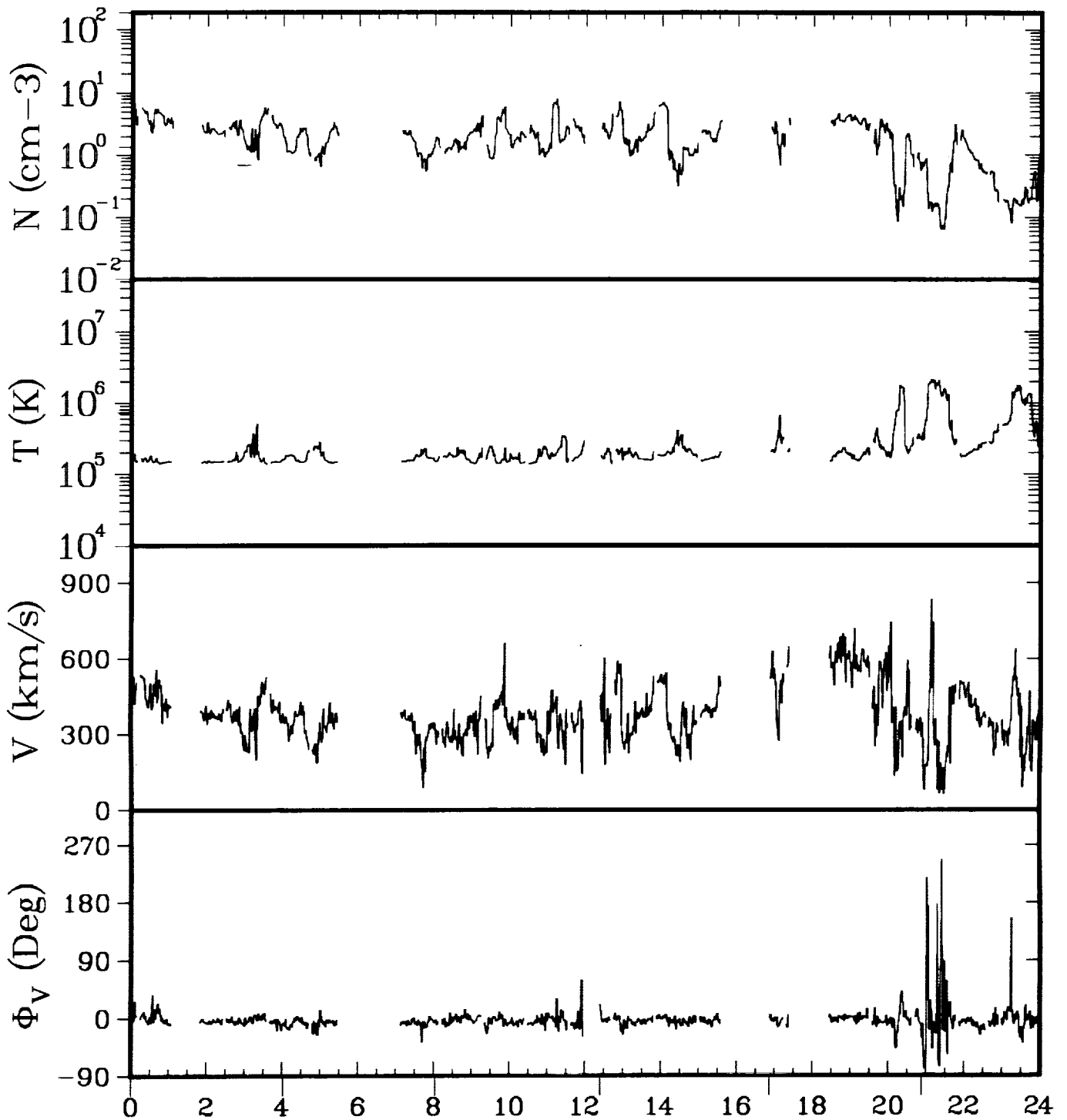

ISEE-3 ELECTRONS 02/13/83

GSEX	-218.6	-218.5	-218.4	-218.3	-218.2	-218.1
Y	31.2	31.5	31.8	32.2	32.5	32.8
Z	-12.6	-12.6	-12.6	-12.6	-12.5	-12.5
GSMY	33.3	34.0	33.5	33.7	34.8	34.7
Z	5.3	0.2	-6.9	-7.7	-1.0	5.5

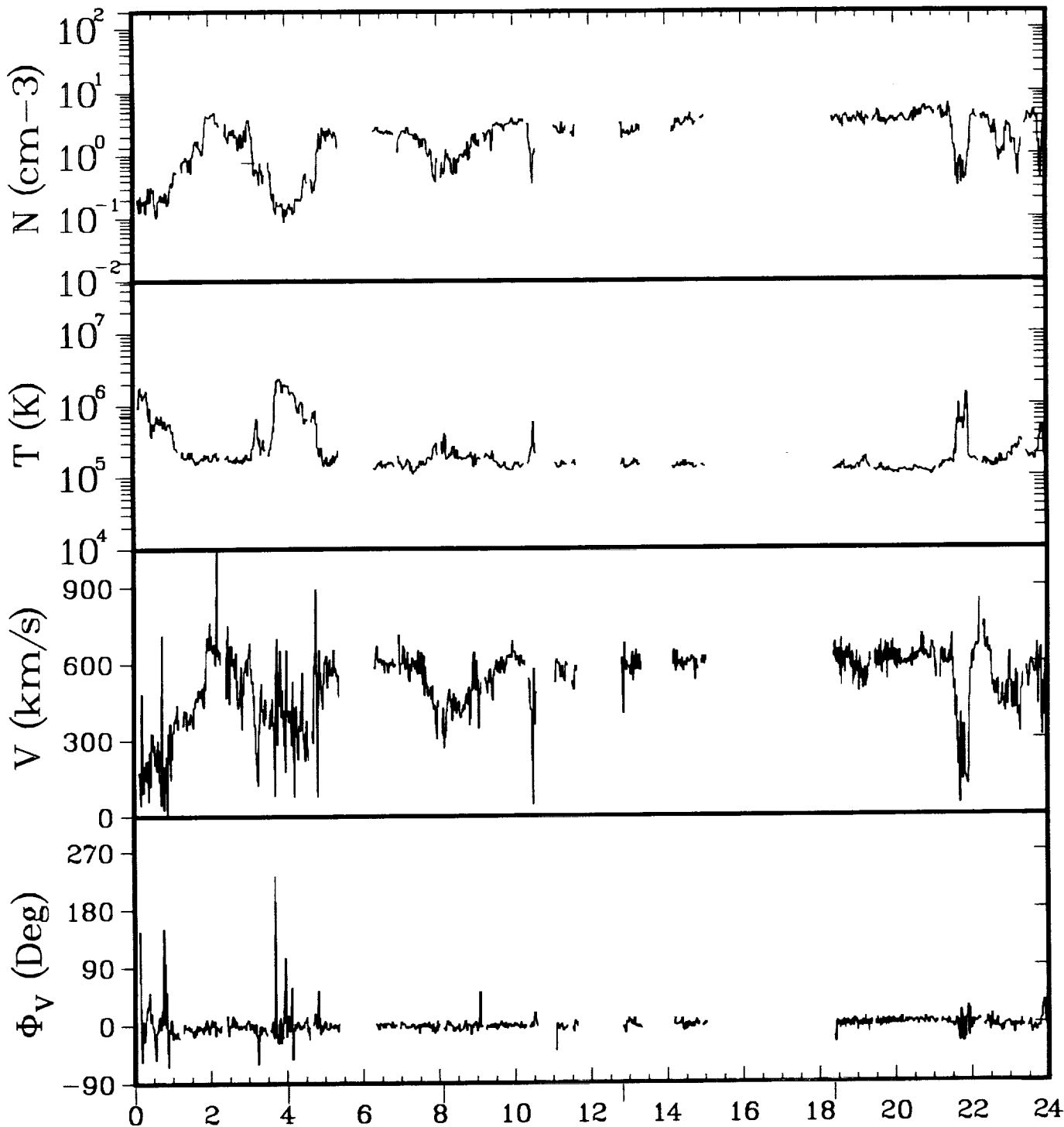

ISEE-3 ELECTRONS 02/14/83

GSEX	-218.1	-218.0	-217.9	-217.7	-217.6
Y	33.0	33.3	33.6	34.0	34.4
Z	-12.5	-12.5	-12.4	-12.4	-12.4
GSMY	34.7	35.6	35.3	35.5	36.4
Z	6.5	1.1	-6.3	-6.7	2.9

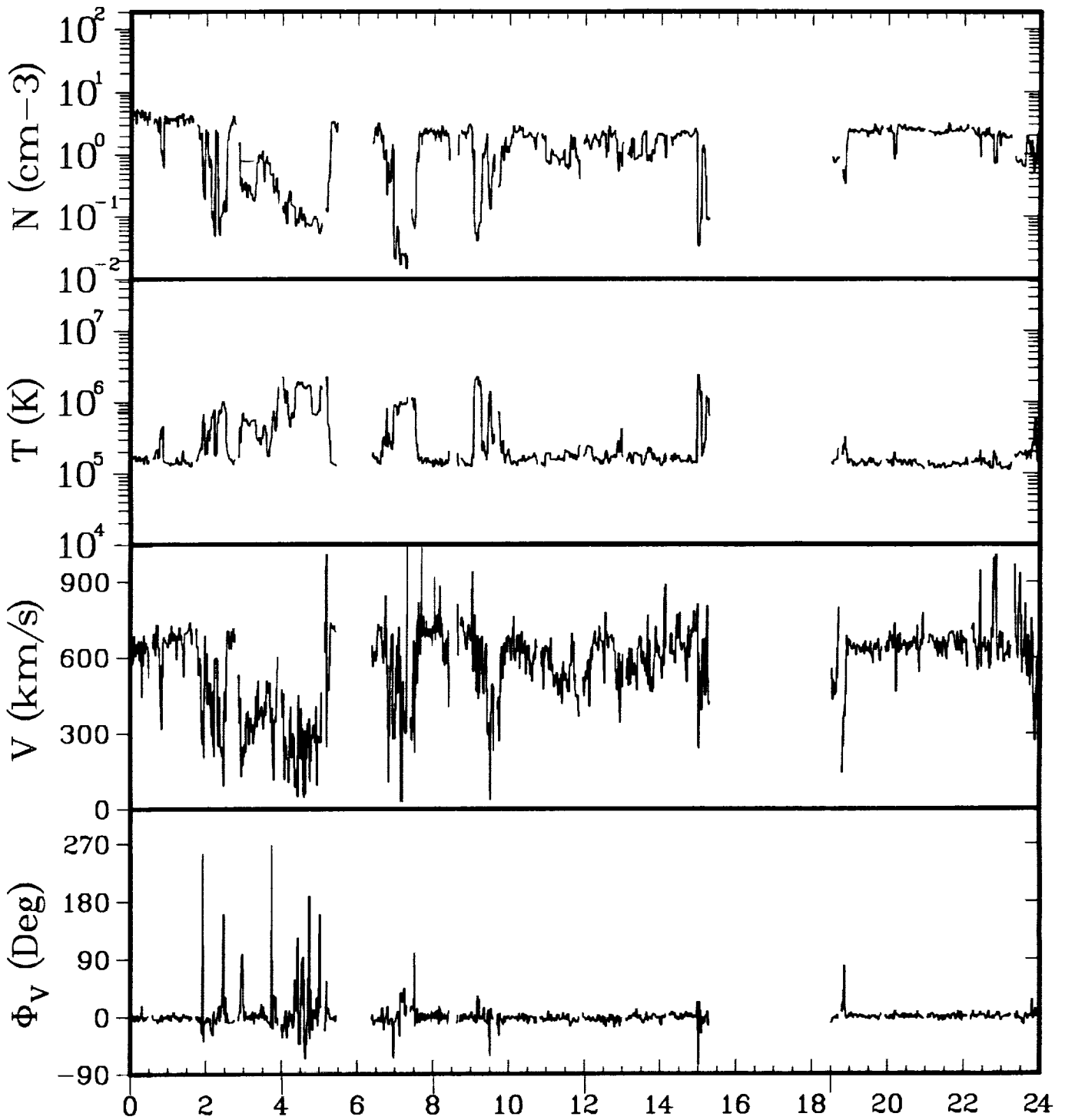

ISEE-3 ELECTRONS 02/15/83

GSEX	-217.5	-217.4	-217.2	-217.1	-217.0
Y	34.8	35.1	35.4	35.7	36.1
Z	-12.3	-12.3	-12.3	-12.2	-12.2
GSMY	36.1	37.1	37.0	37.1	37.9
Z	7.6	2.1	-5.6	-6.9	4.1

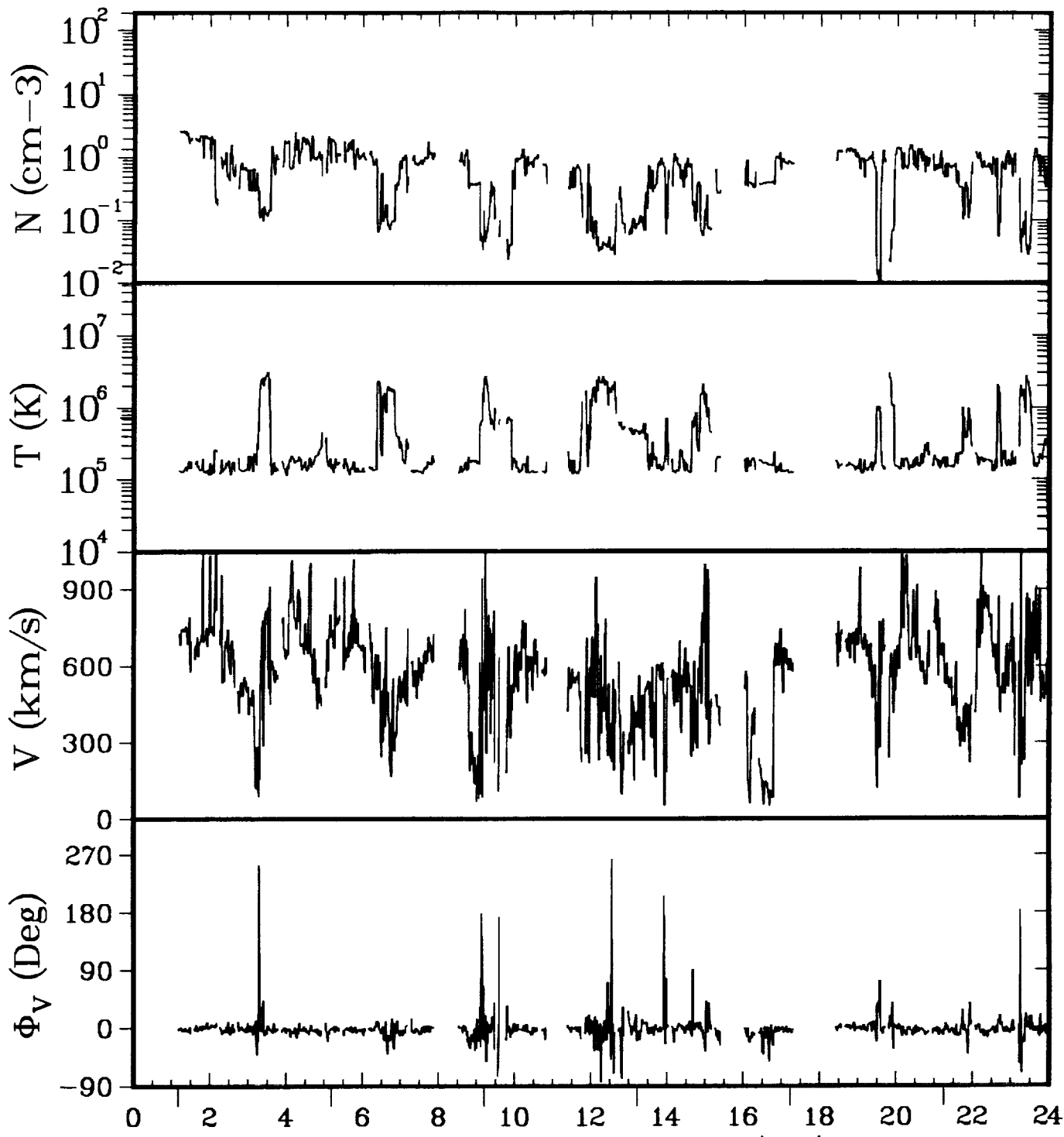

ISEE-3 ELECTRONS 02/16/83

GSEX	-216.8	-216.6	-216.5	-216.4	-216.3	-216.2
Y	36.6	36.8	37.1	37.4	37.6	37.9
Z	-12.1	-12.1	-12.1	-12.0	-12.0	-11.9
GSMY	37.7	38.8	38.5	38.9	39.4	38.7
Z	7.9	0.4	-6.2	-5.0	2.5	9.3

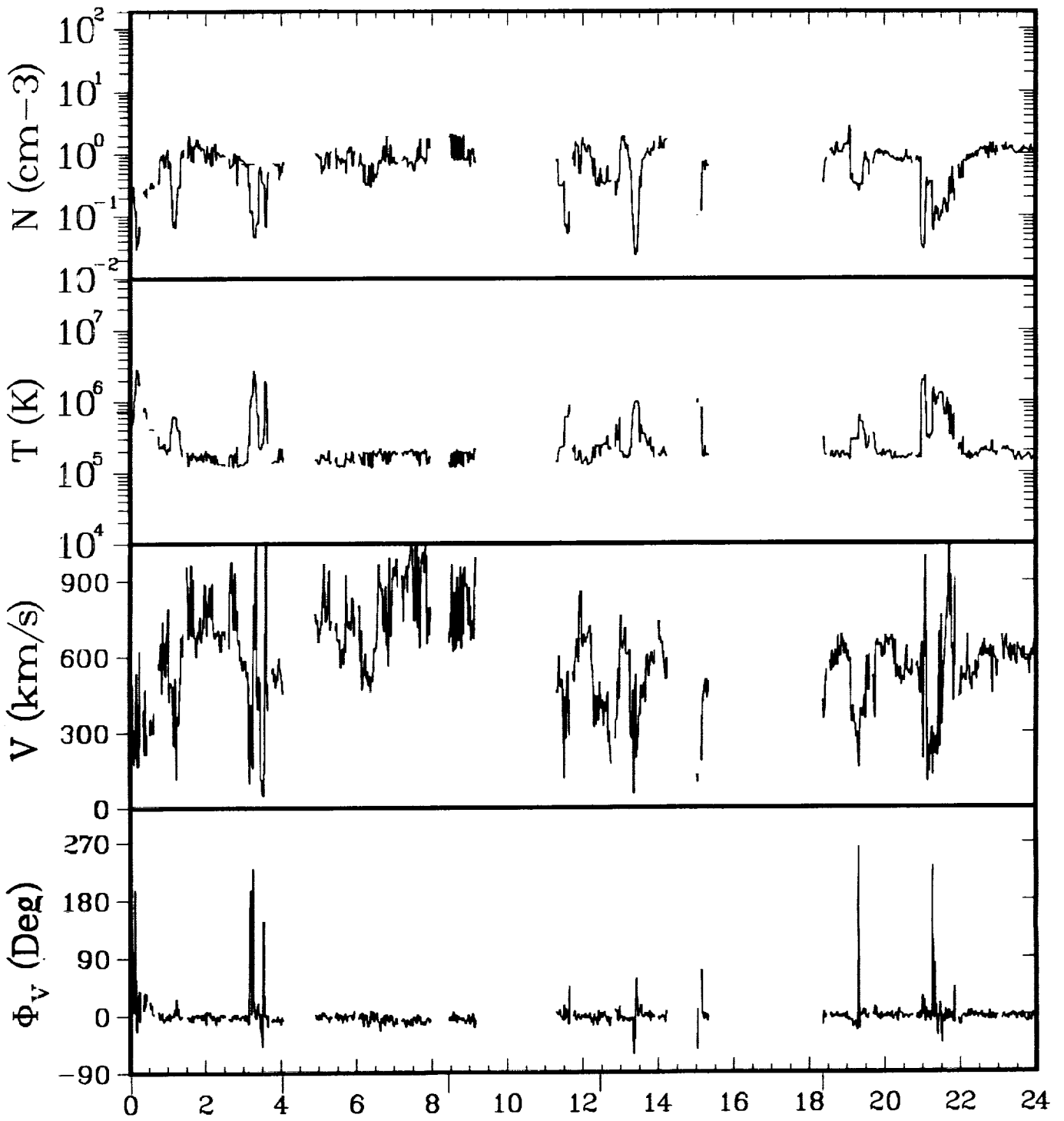

ISEE-3 ELECTRONS 02/17/83

GSEX	-216.1	-215.9	-215.8	-215.7	-215.5
Y	38.1	38.4	38.6	38.9	39.3
Z	-11.9	-11.9	-11.8	-11.8	-11.8
GSMY	38.7	40.0	40.1	40.3	40.6
Z	9.9	3.9	-4.9	-5.3	5.8

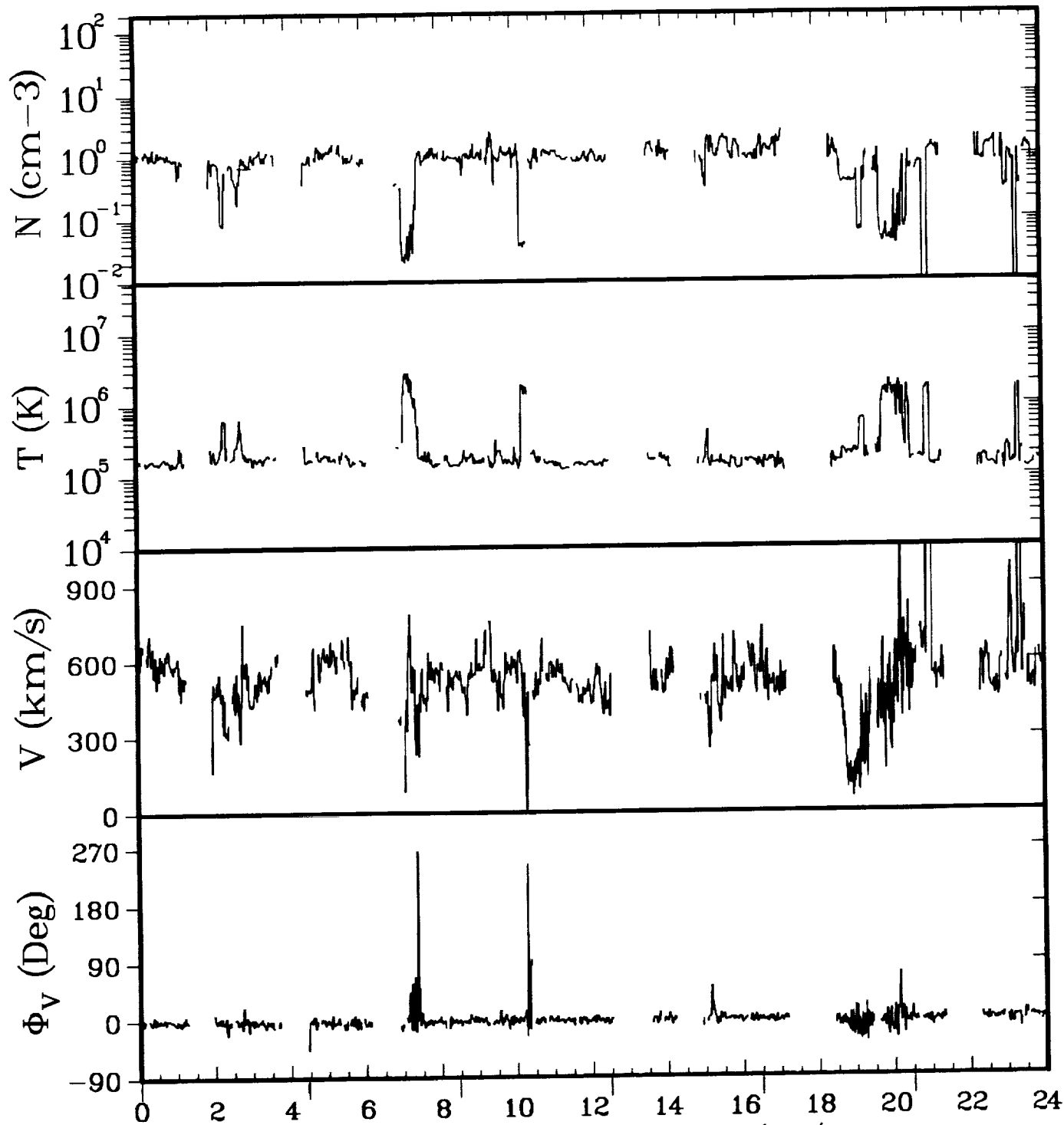

ISEE-3 ELECTRONS 02/18/83

GSEX	-215.3	-215.1	-215.0	-214.8	-214.7	-214.5
Y	39.6	39.9	40.1	40.3	40.6	40.8
Z	-11.7	-11.7	-11.6	-11.6	-11.5	-11.5
GSMY	39.8	41.4	41.5	41.7	42.1	41.0
Z	11.1	3.9	-4.2	-4.6	2.6	10.6

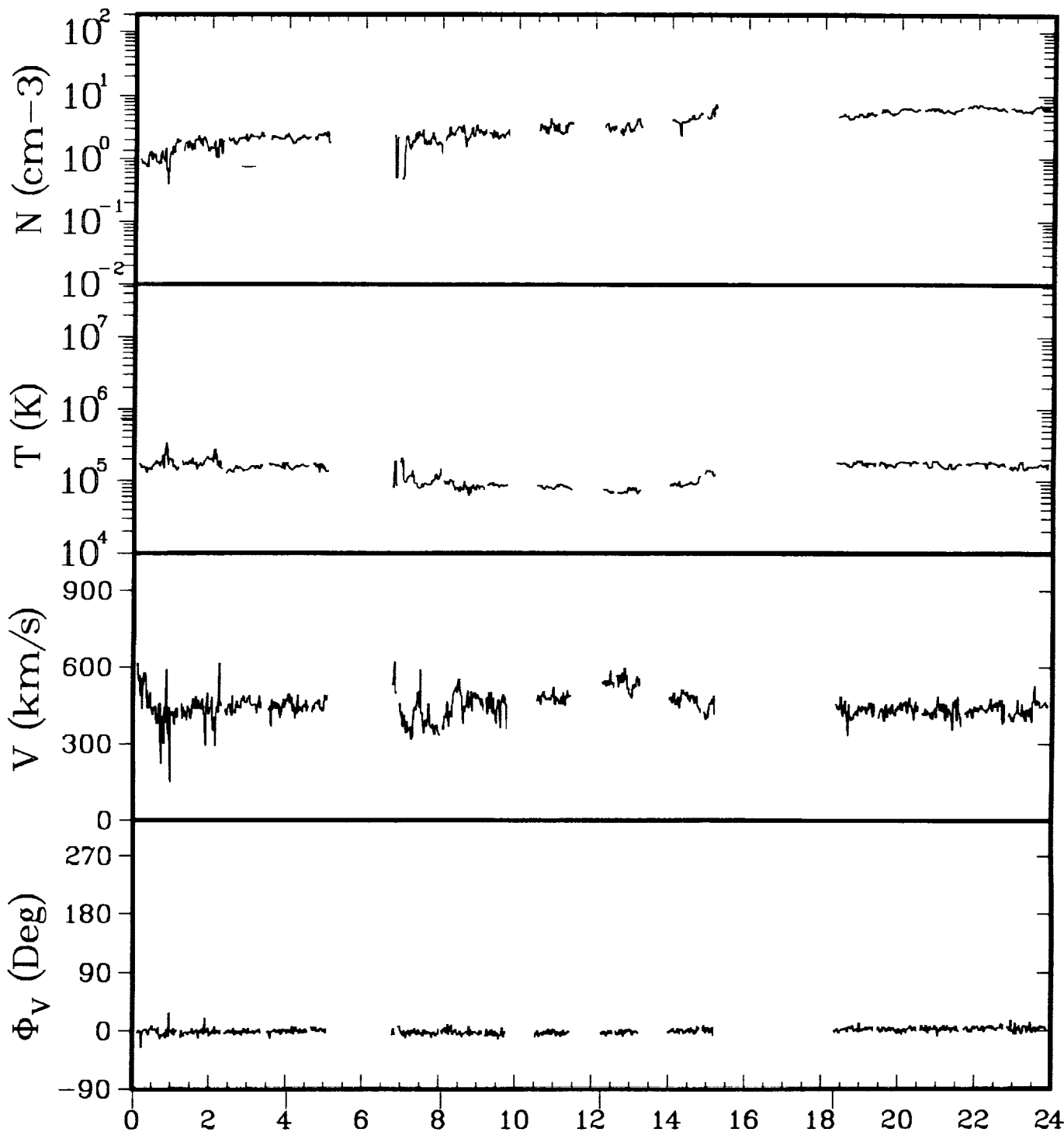

ISEE-3 ELECTRONS 02/19/83

GSEX	-214.4	-214.3	-214.1	-213.9	-213.7
Y	41.0	41.2	41.4	41.7	42.0
Z	-11.5	-11.4	-11.4	-11.3	-11.3
GSMY	40.8	42.4	42.9	43.0	42.8
Z	12.1	5.8	-3.0	-4.2	7.7

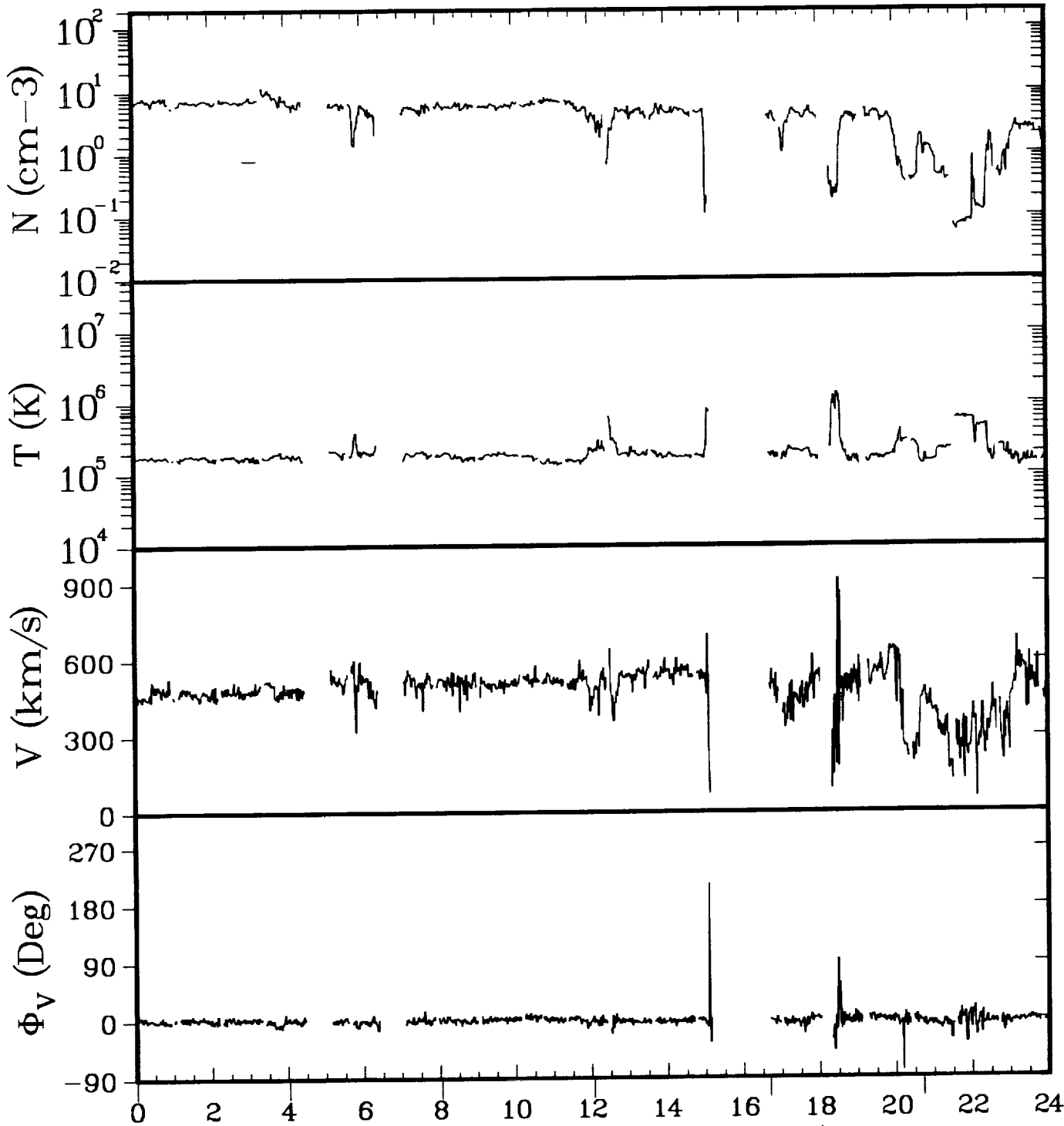

ISEE-3 ELECTRONS 02/20/83

GSEX	-213.5	-213.3	-213.1	-213.0	-212.8	-212.6
Y	42.3	42.5	42.7	42.9	43.1	43.3
Z	-11.2	-11.1	-11.1	-11.0	-11.0	-10.9
GSMY	41.7	43.4	44.0	44.1	44.2	42.8
Z	13.2	6.6	-2.3	-3.8	4.8	12.9

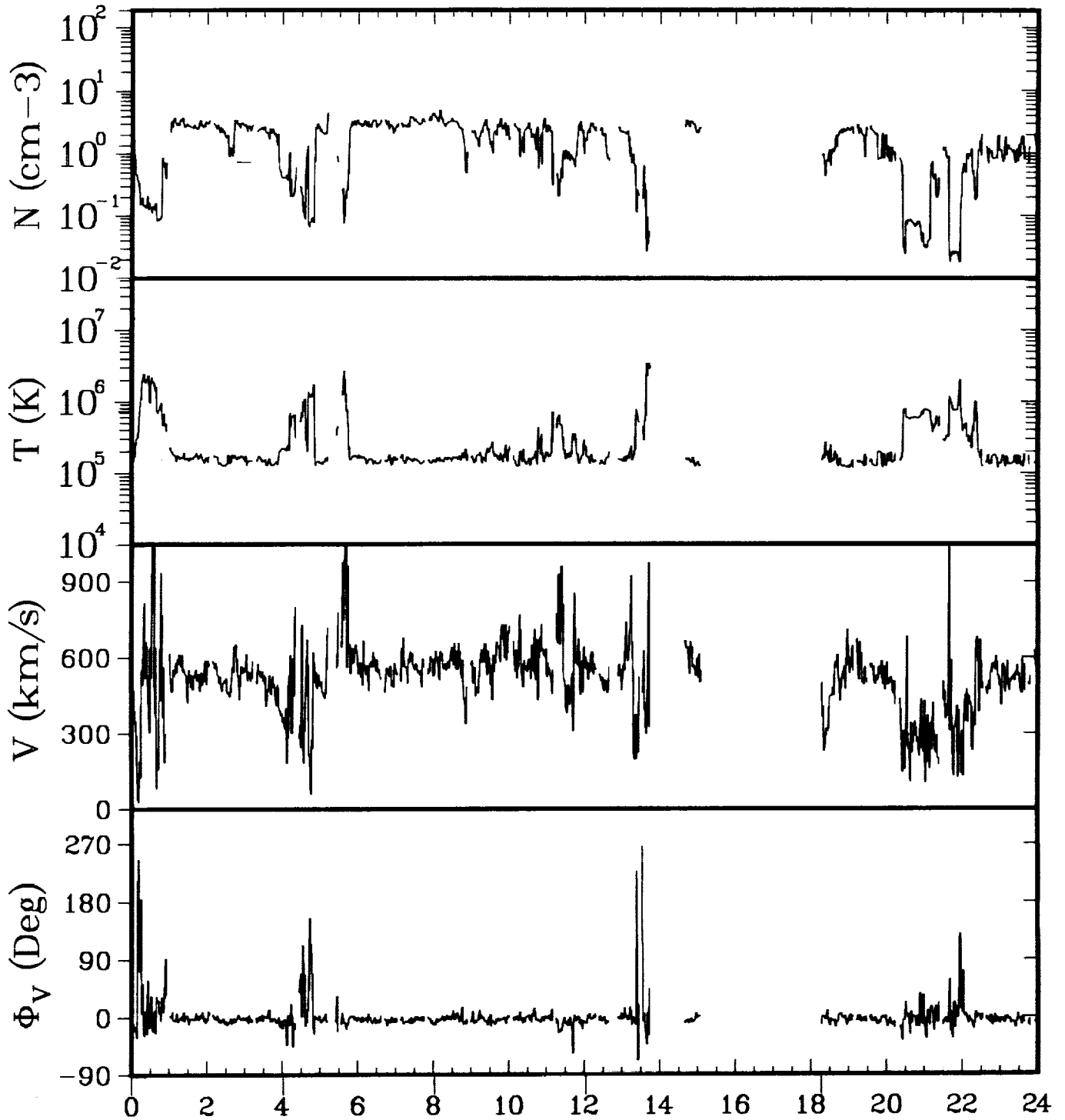

ISEE-3 ELECTRONS 02/21/83

GSEX	-212.4	-212.3	-212.1	-211.9	-211.6
Y	43.5	43.6	43.8	44.0	44.3
Z	-10.9	-10.9	-10.8	-10.8	-10.7
GSMY	42.5	44.3	45.1	45.2	44.6
Z	14.2	7.5	-1.7	-3.2	9.3

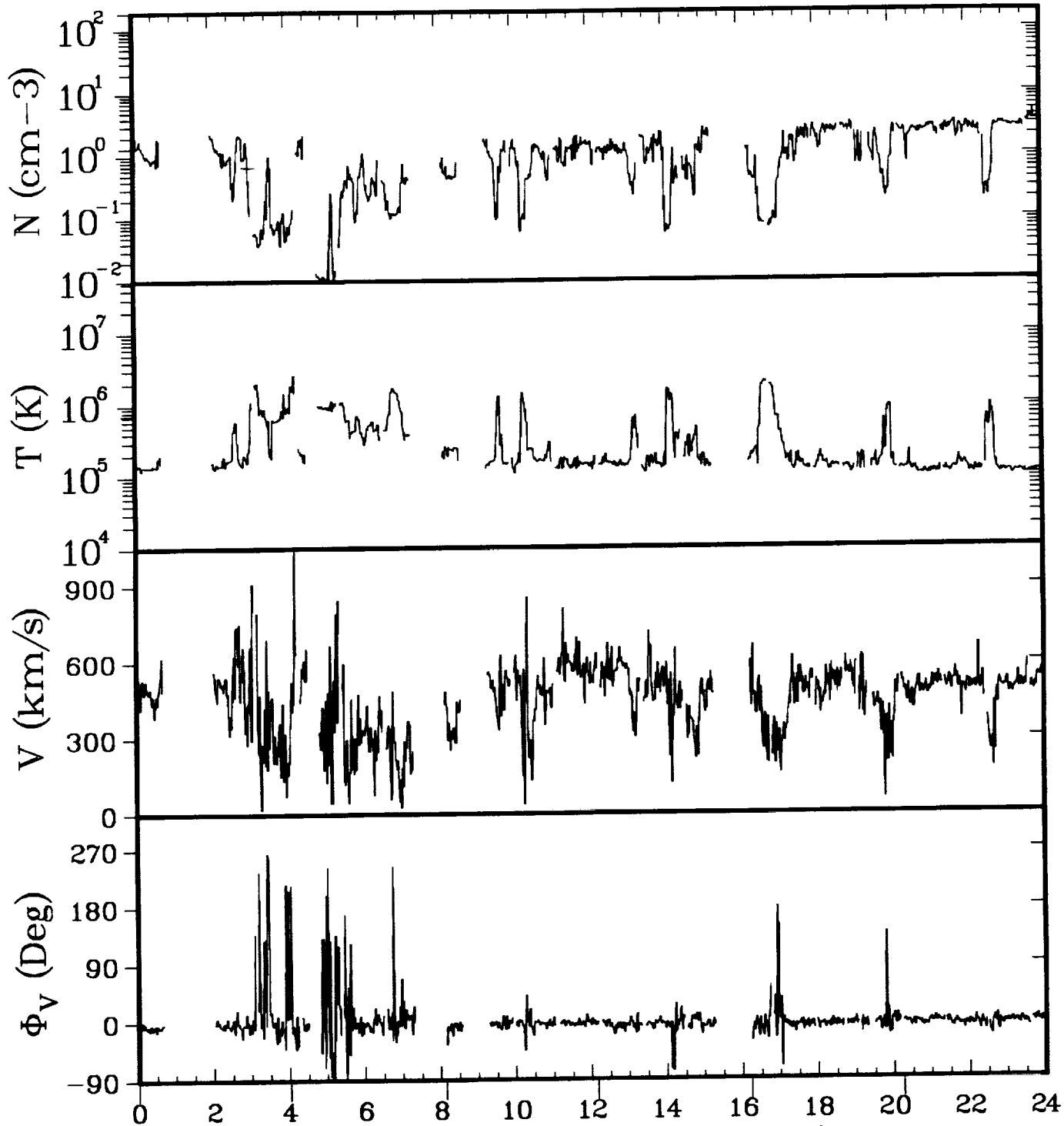

ISEE-3 ELECTRONS 02/22/83

GSEX	-211.3	-211.1	-210.9	-210.7	-210.5	-210.3
Y	44.5	44.7	44.8	45.0	45.1	45.3
Z	-10.6	-10.6	-10.5	-10.4	-10.4	-10.3
GSMY	43.2	45.1	46.0	46.1	46.0	44.3
Z	15.1	8.4	-1.2	-2.5	5.2	14.0

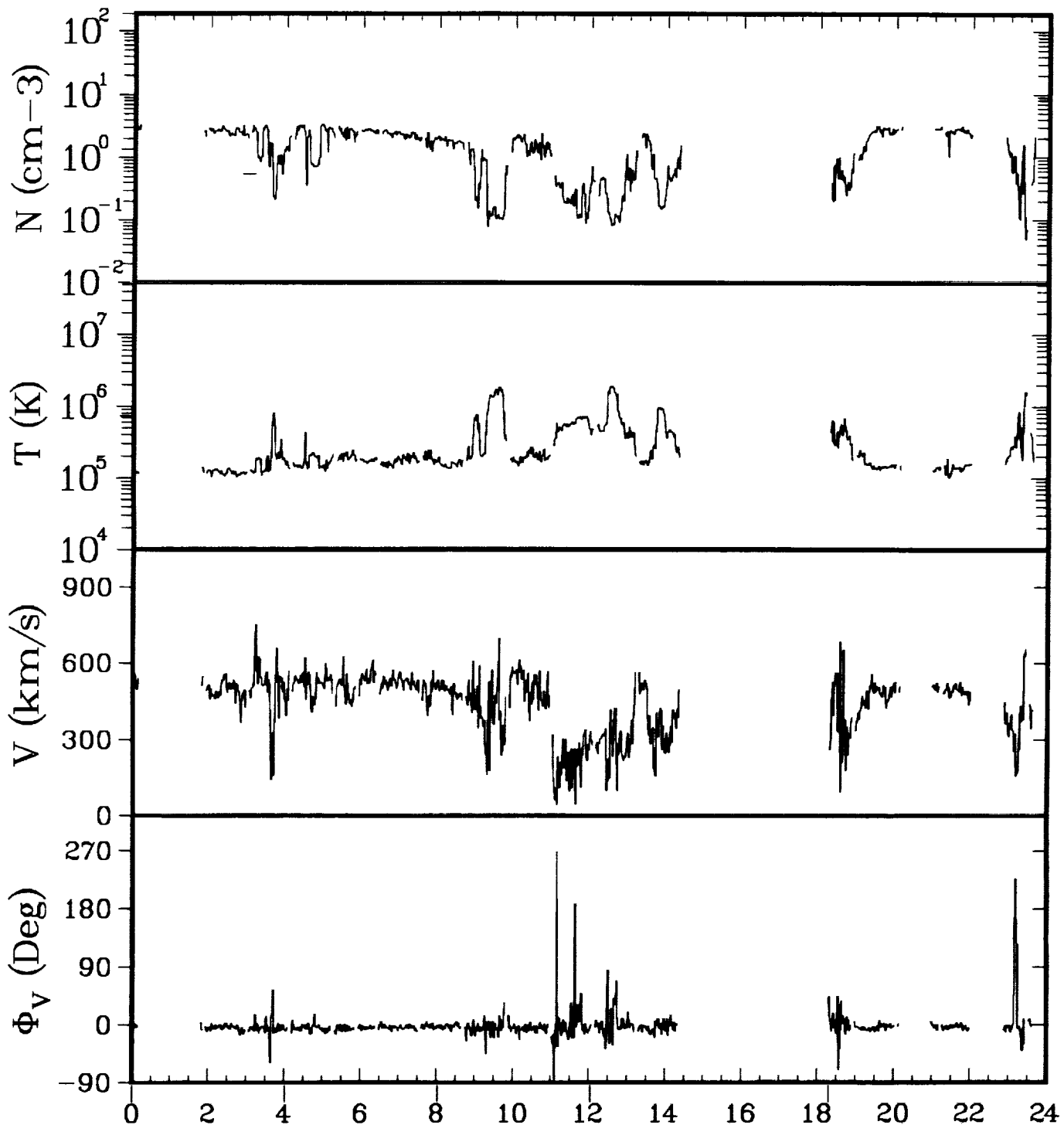

ISEE-3 ELECTRONS 02/23/83

GSEX	-210.1	-209.9	-209.7	-209.5	-209.1
Y	45.4	45.5	45.7	45.8	46.0
Z	-10.3	-10.2	-10.2	-10.1	-10.0
GSMY	43.7	45.8	46.8	46.9	45.8
Z	16.0	9.1	-0.4	-1.9	11.0

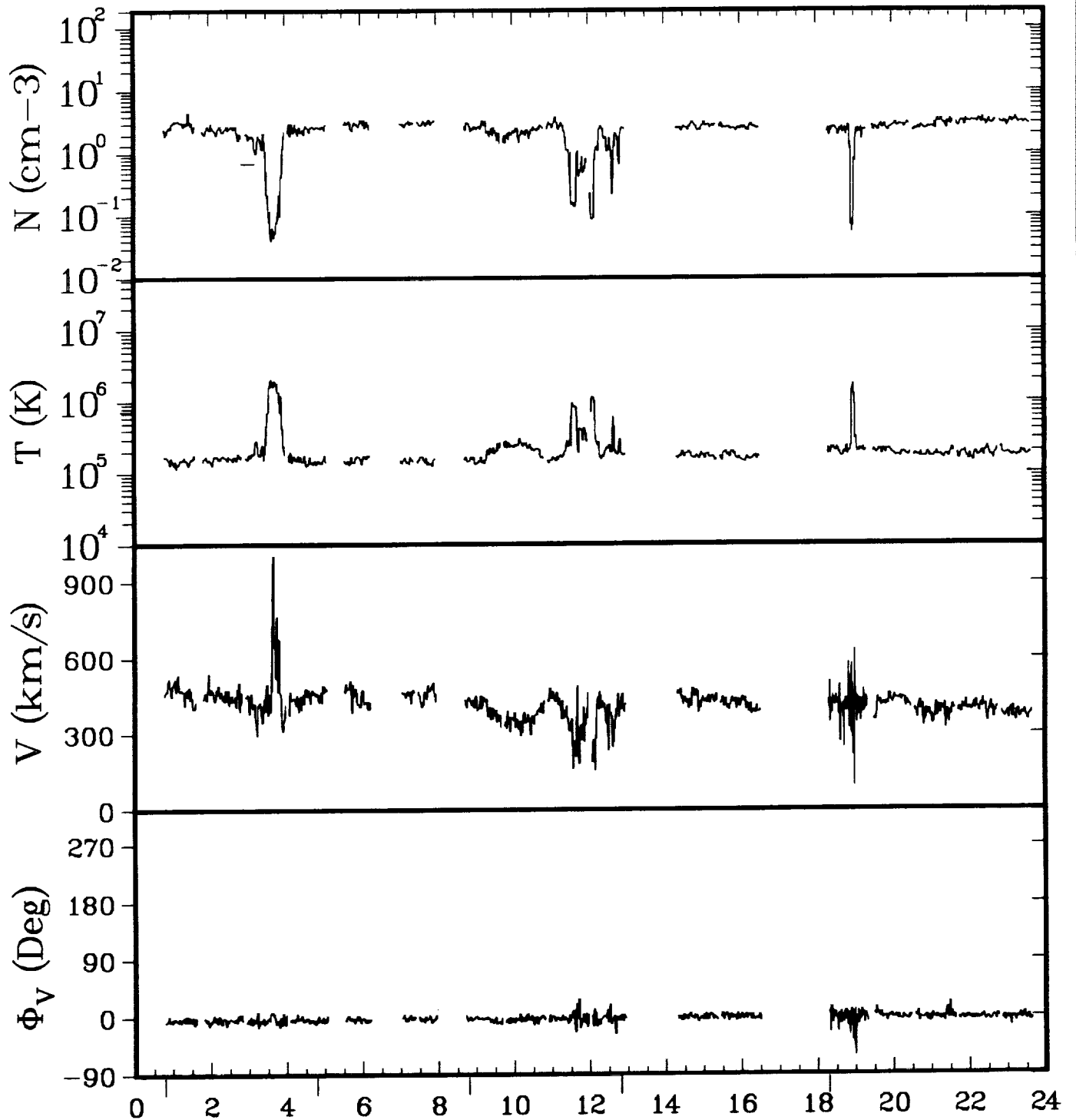

ISEE-3 ELECTRONS 02/24/83

GSEX	-208.8	-208.5	-208.3	-208.1	-207.7
Y	46.2	46.3	46.4	46.5	46.7
Z	-9.9	-9.9	-9.8	-9.8	-9.7
GSMY	44.4	46.7	47.4	47.5	46.2
Z	16.1	7.8	-0.8	-0.5	11.7

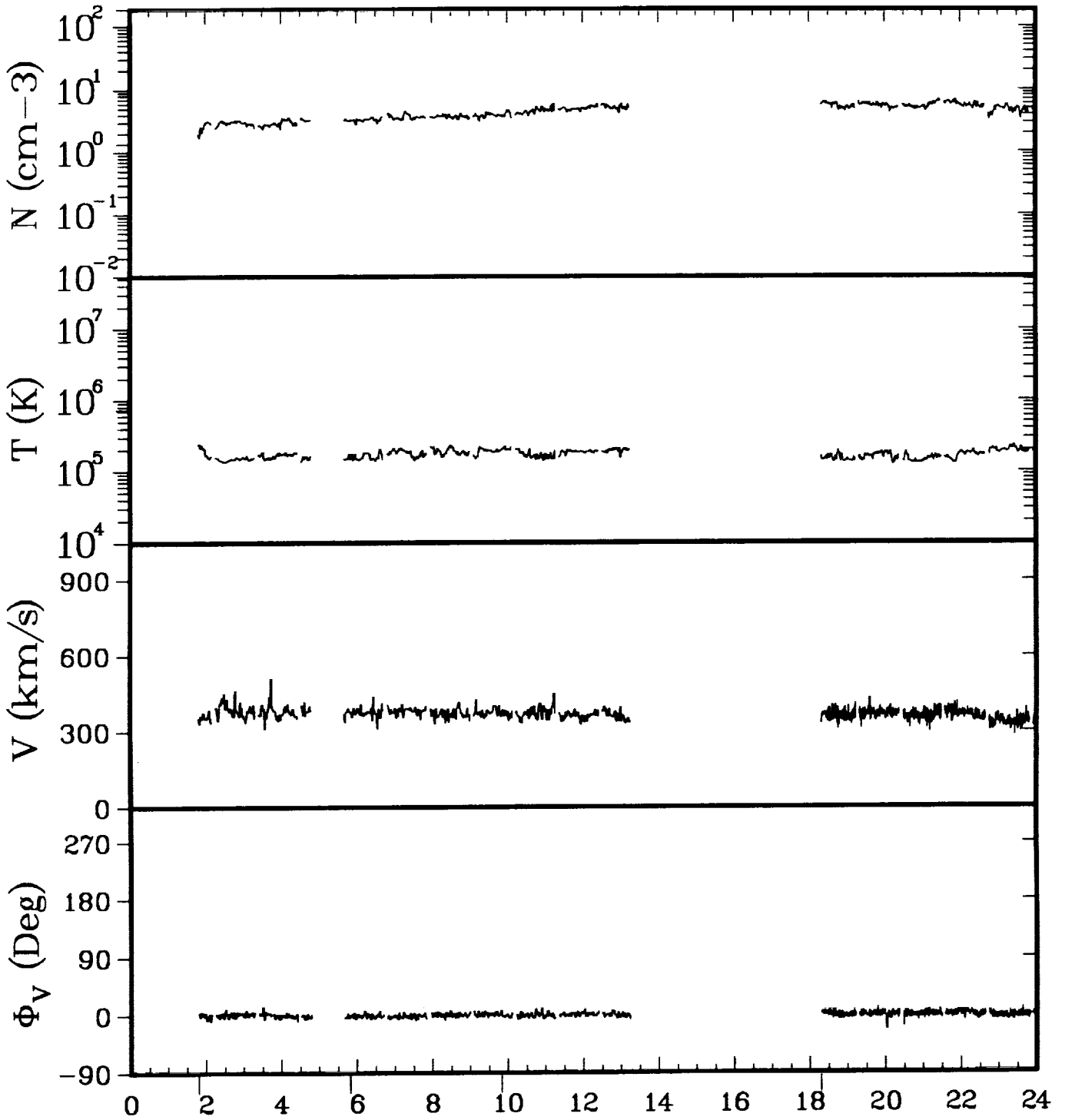

ISEE-3 ELECTRONS 02/25/83

GSEX	-207.3	-207.0	-206.8	-206.2
Y	46.8	46.9	47.0	47.2
Z	-9.6	-9.5	-9.5	-9.3
GSMY	45.3	47.5	48.0	46.5
Z	15.4	5.8	-1.2	12.4

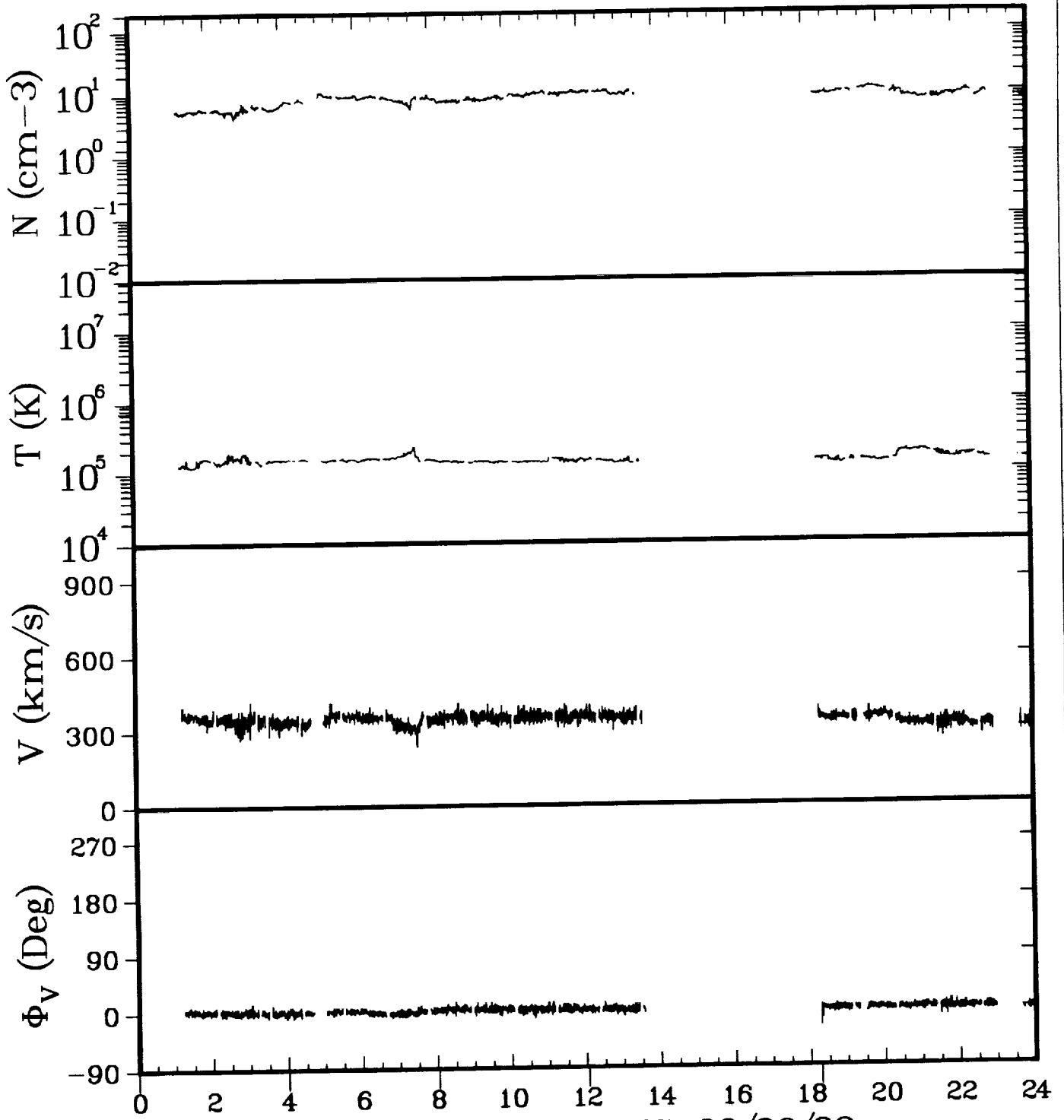

ISEE-3 ELECTRONS 02/26/83

GSEX	-205.8	-205.6	-205.3	-205.0	-204.6
Y	47.3	47.4	47.4	47.5	47.6
Z	-9.3	-9.2	-9.1	-9.1	-9.0
GSMY	44.6	47.0	48.3	48.4	46.7
Z	18.2	11.2	1.5	-0.2	13.0

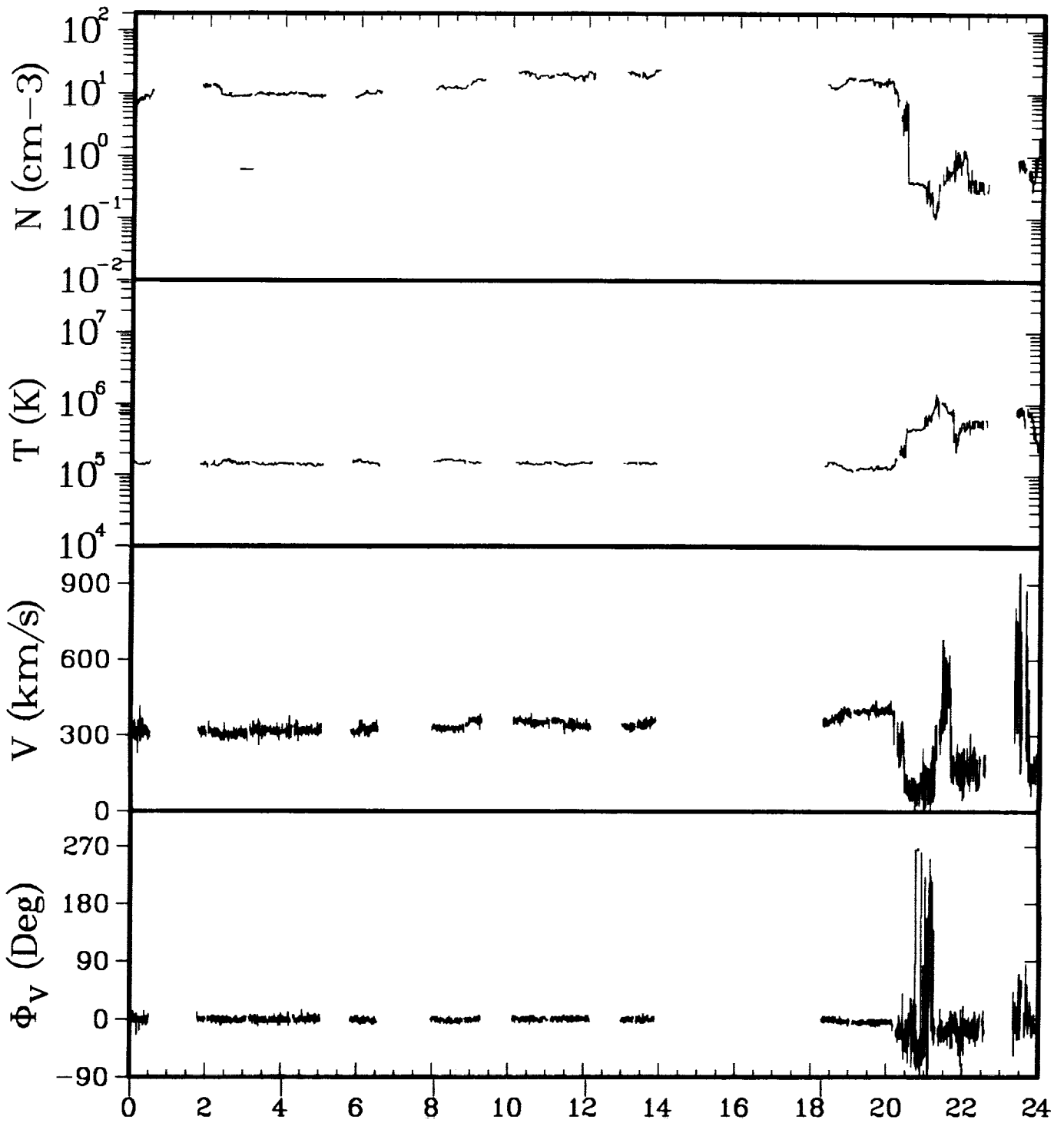

ISEE-3 ELECTRONS 02/27/83

GSEX	-204.2	-203.9	-203.6	-203.3	-202.8
Y	47.7	47.7	47.8	47.8	47.9
Z	-8.9	-8.8	-8.8	-8.7	-8.6
GSMY	44.7	47.1	48.5	48.6	46.7
Z	18.8	11.7	2.0	0.4	13.6

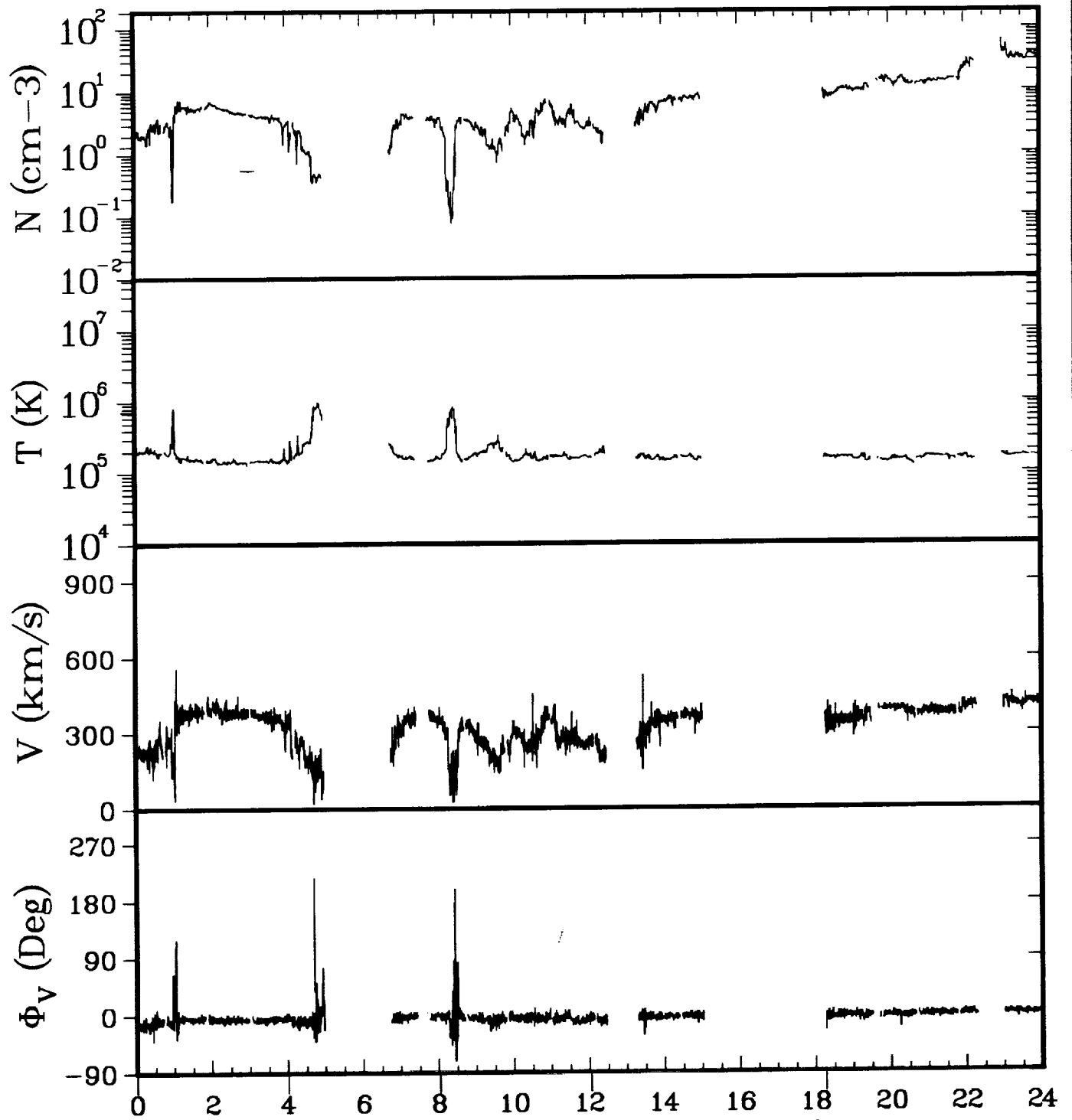

ISEE-3 ELECTRONS 02/28/83

GSEX	-202.4	-202.1	-201.7	-201.4	-200.9
Y	47.9	47.9	48.0	48.0	48.0
Z	-8.5	-8.4	-8.4	-8.3	-8.2
GSMY	44.7	47.1	48.6	48.7	46.6
Z	19.3	12.3	2.6	0.9	14.1

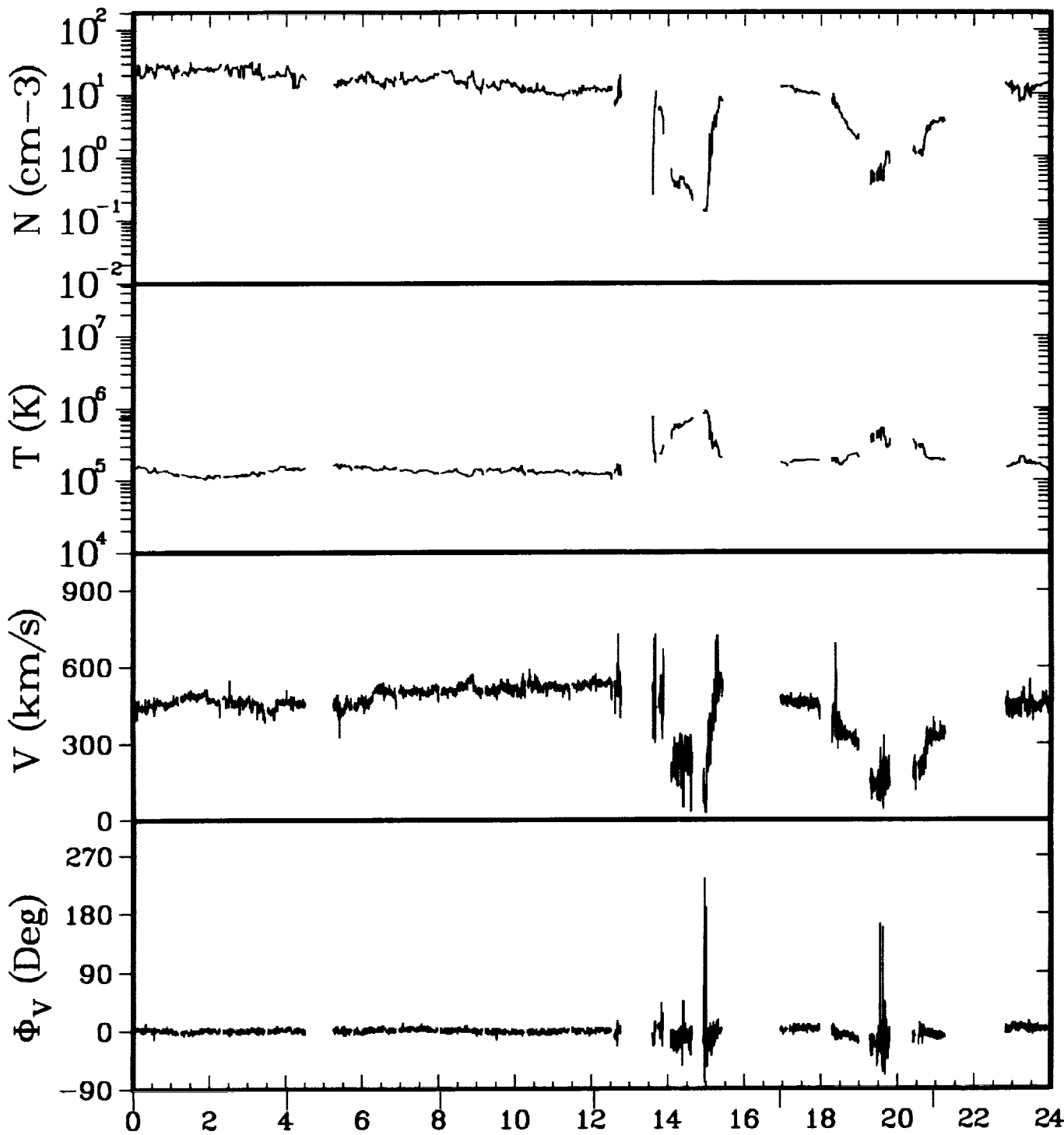

ISEE-3 ELECTRONS 03/01/83

GSEX	-200.4	-200.1	-199.8	-199.4	-199.0	-198.7
Y	48.0	48.0	48.1	48.1	48.1	48.0
Z	-8.1	-8.0	-8.0	-7.9	-7.8	-7.8
GSMY	44.5	47.0	48.6	48.7	47.4	44.6
Z	19.8	12.7	3.1	1.4	11.3	19.4

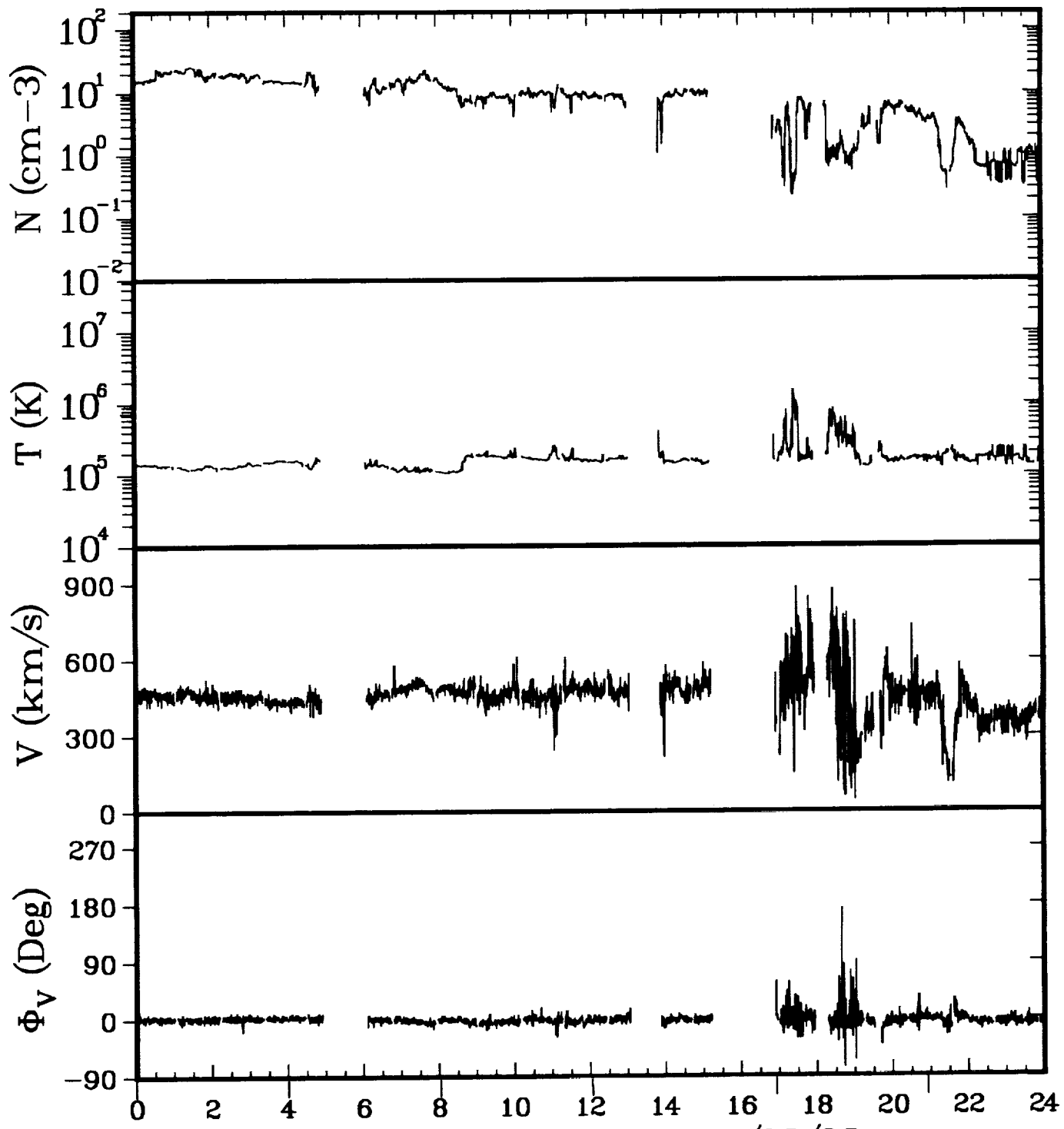

ISEE-3 ELECTRONS 03/02/83

GSEX	-198.4	-198.0	-197.7	-197.3	-196.9	-196.5
Y	48.0	48.0	48.0	48.0	48.0	47.9
Z	-7.7	-7.6	-7.6	-7.5	-7.4	-7.4
GSMY	44.2	46.8	48.5	48.5	47.1	44.3
Z	20.2	13.2	3.6	1.9	11.7	19.7

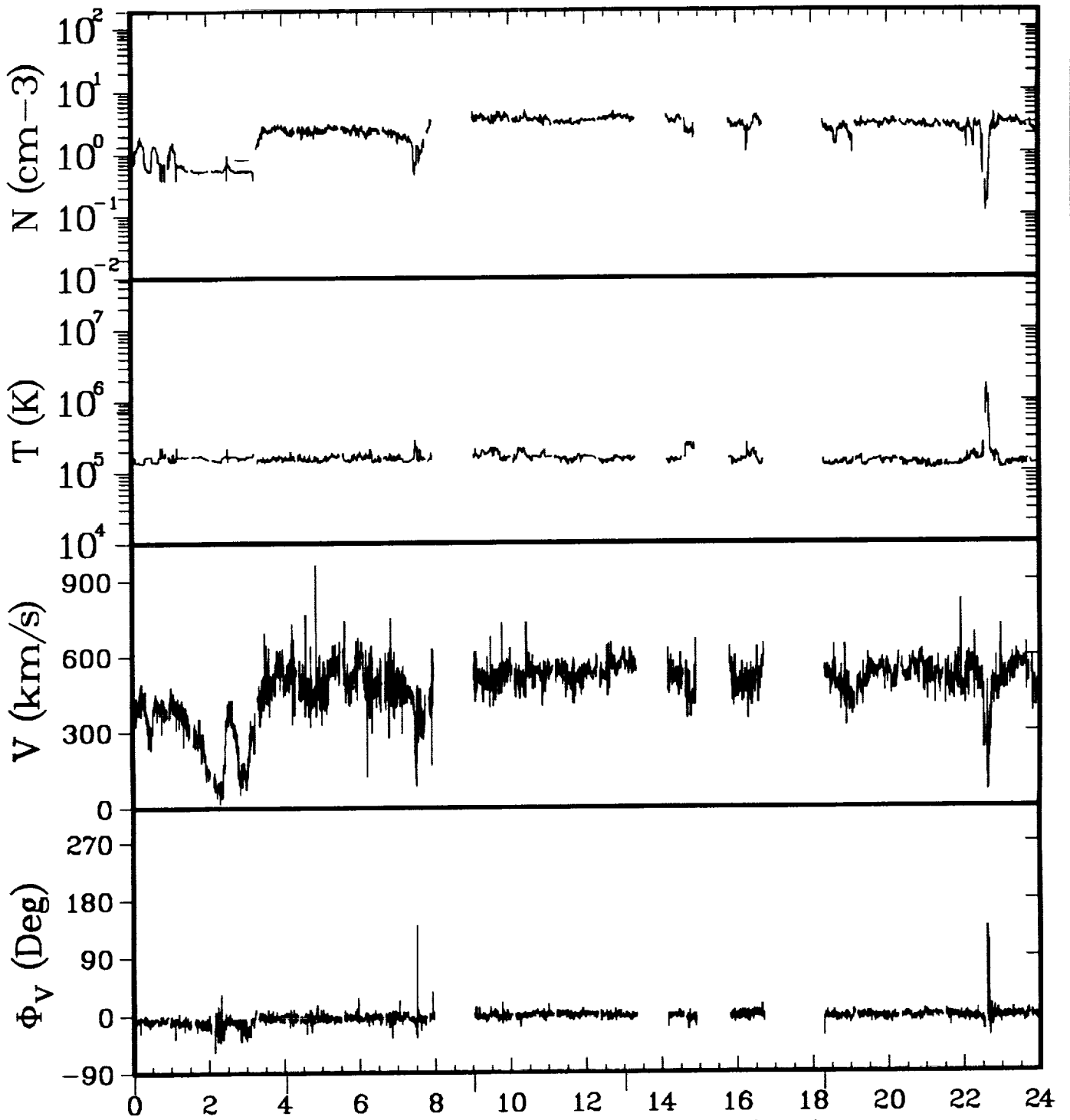

ISEE-3 ELECTRONS 03/03/83

GSEX	-196.2	-195.8	-195.4	-195.0	-194.5
Y	47.9	47.9	47.8	47.8	47.8
Z	-7.3	-7.2	-7.2	-7.1	-7.0
GSMY	43.9	46.5	48.3	48.2	45.7
Z	20.6	13.5	2.7	3.5	15.4

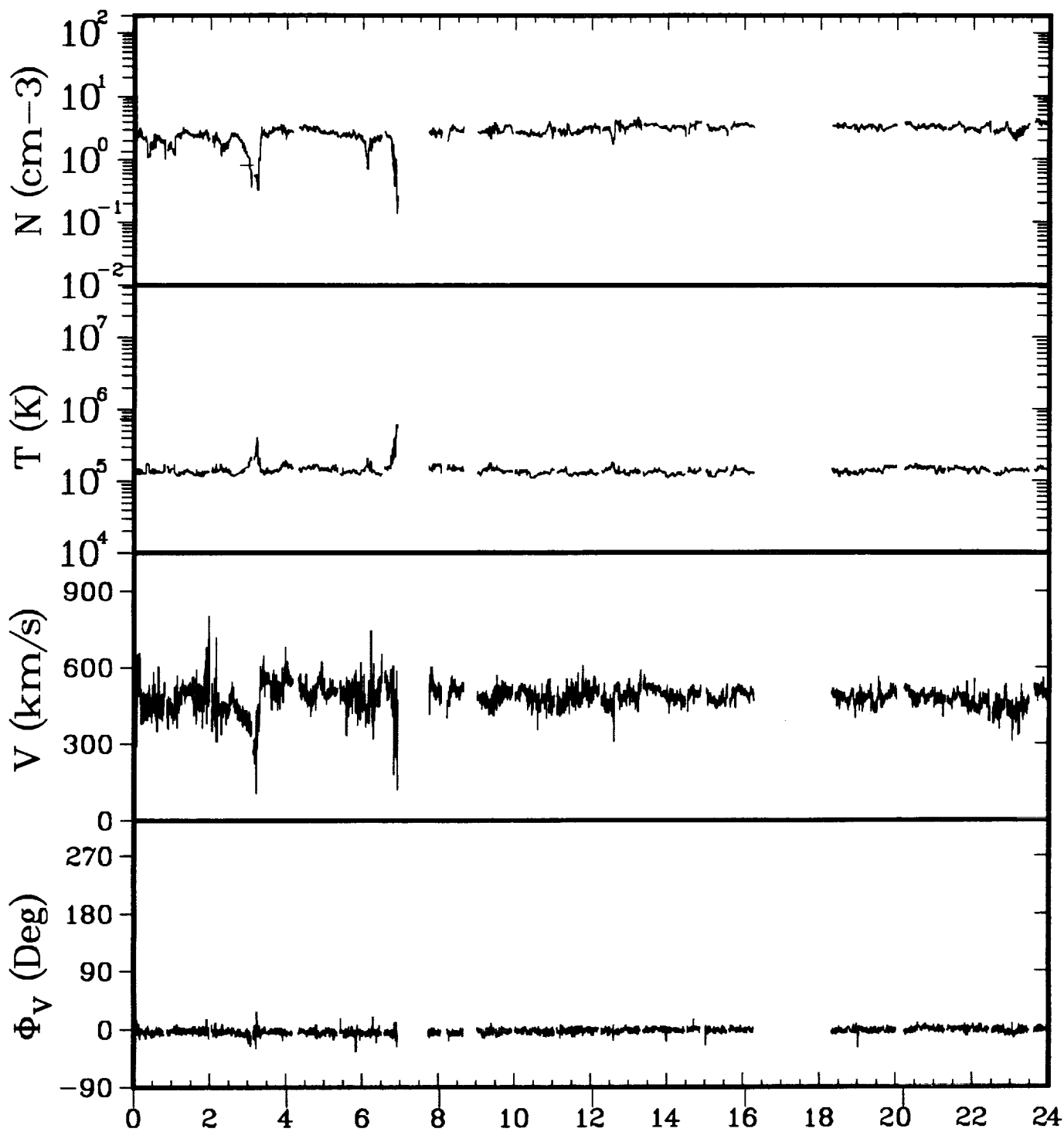

ISEE-3 ELECTRONS 03/04/83

GSEX	-193.9	-193.5	-193.1	-192.7	-192.3	-191.9
Y	47.7	47.6	47.6	47.5	47.5	47.4
Z	-6.9	-6.8	-6.8	-6.7	-6.6	-6.6
GSMY	43.4	46.1	47.8	47.9	46.8	43.7
Z	20.9	14.0	4.5	2.8	10.3	19.4

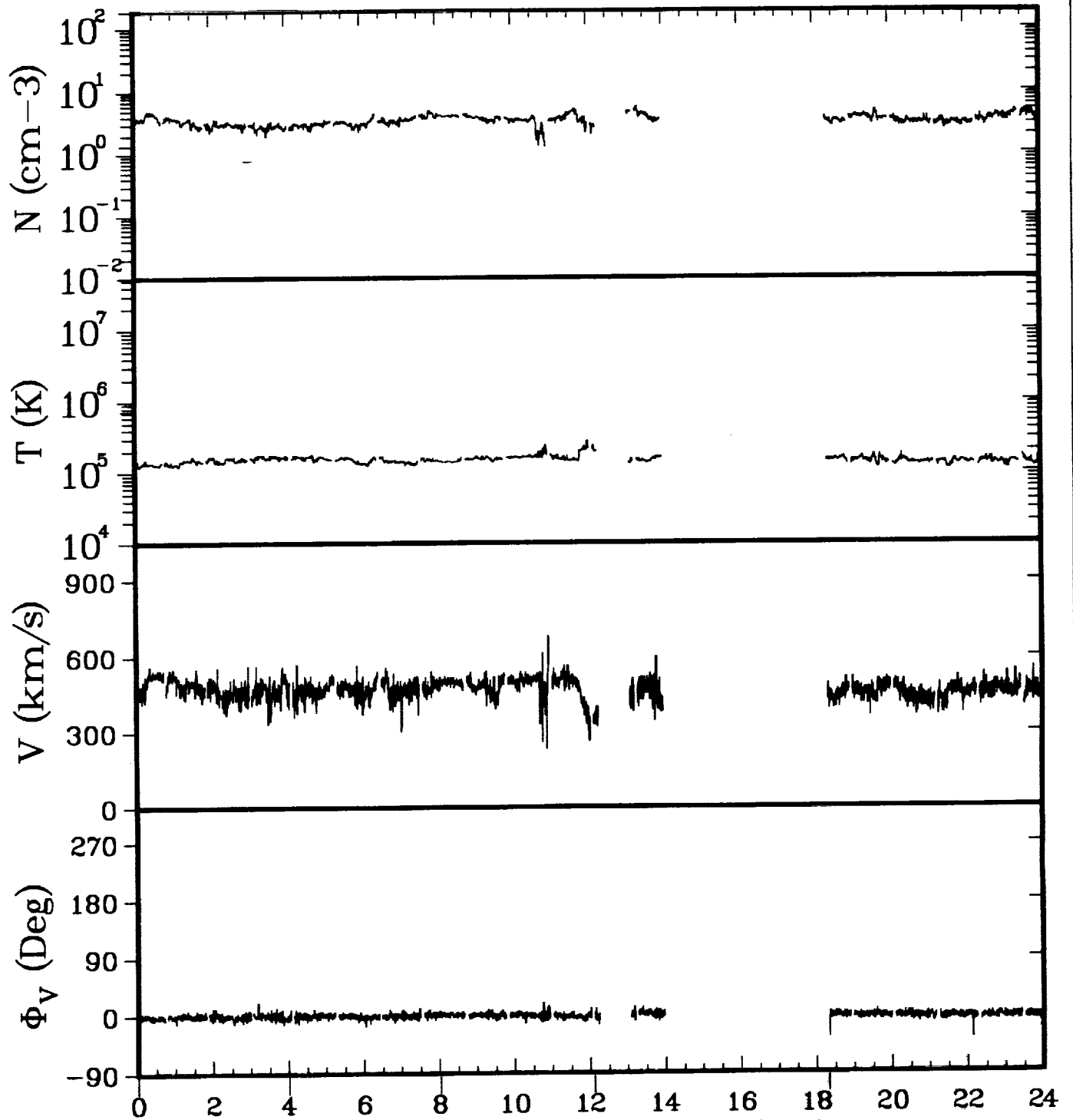

GSEX	-191.5	-191.1	-190.7	-190.3	-189.6
Y	47.3	47.3	47.2	47.1	47.0
Z	-6.5	-6.4	-6.3	-6.3	-6.2
GSMY	42.9	45.5	47.4	47.4	44.6
Z	21.1	14.3	4.9	3.3	16.1

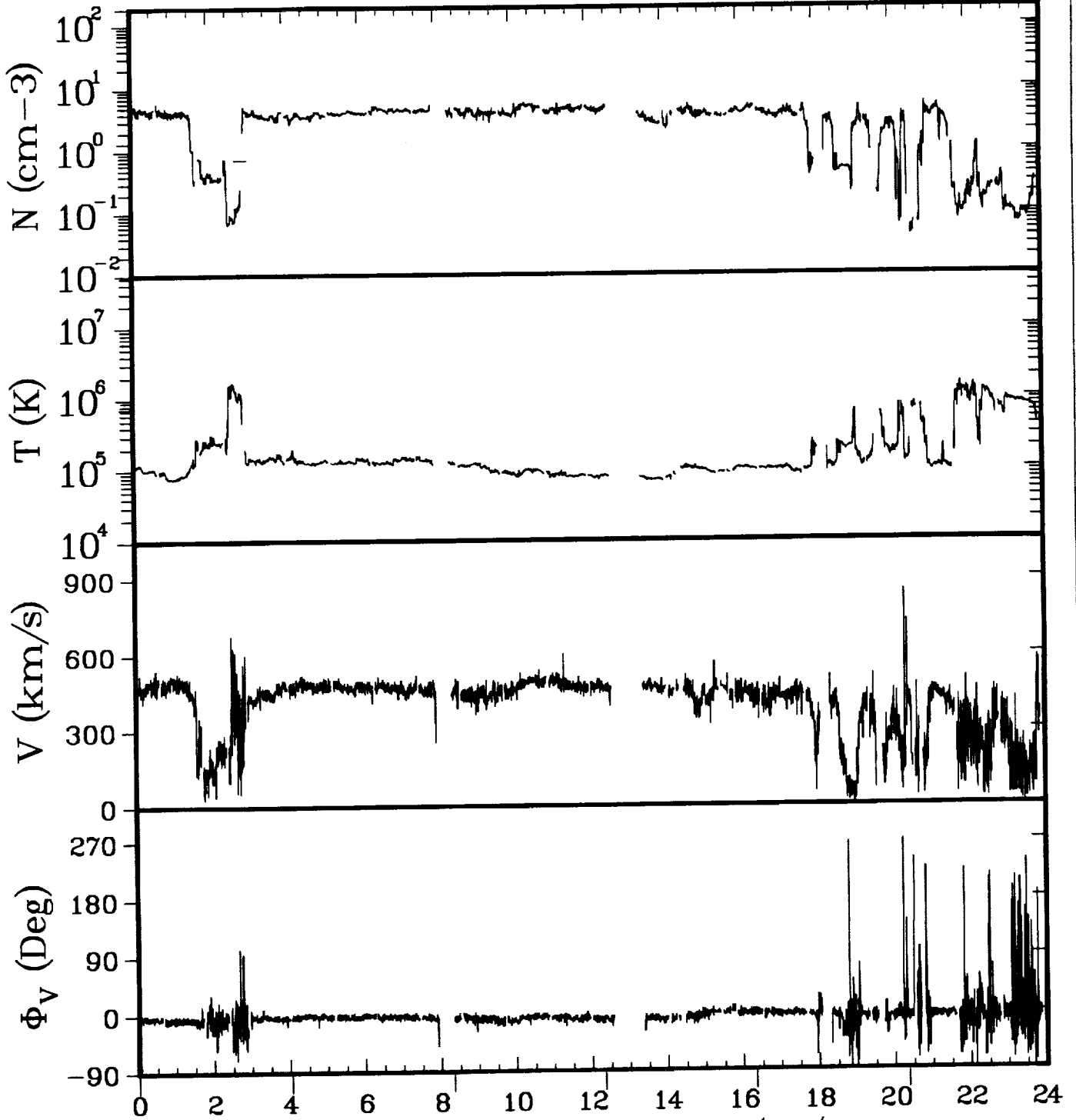

ISEE-3 ELECTRONS 03/06/83

GSEX	-189.0	-188.6	-188.1	-187.7	-187.2	-186.8
Y	46.8	46.8	46.6	46.5	46.4	46.3
Z	-6.1	-6.0	-5.9	-5.8	-5.8	-5.7
GSMY	42.2	44.9	46.8	46.8	45.4	42.2
Z	21.2	14.4	4.8	3.9	11.6	19.9

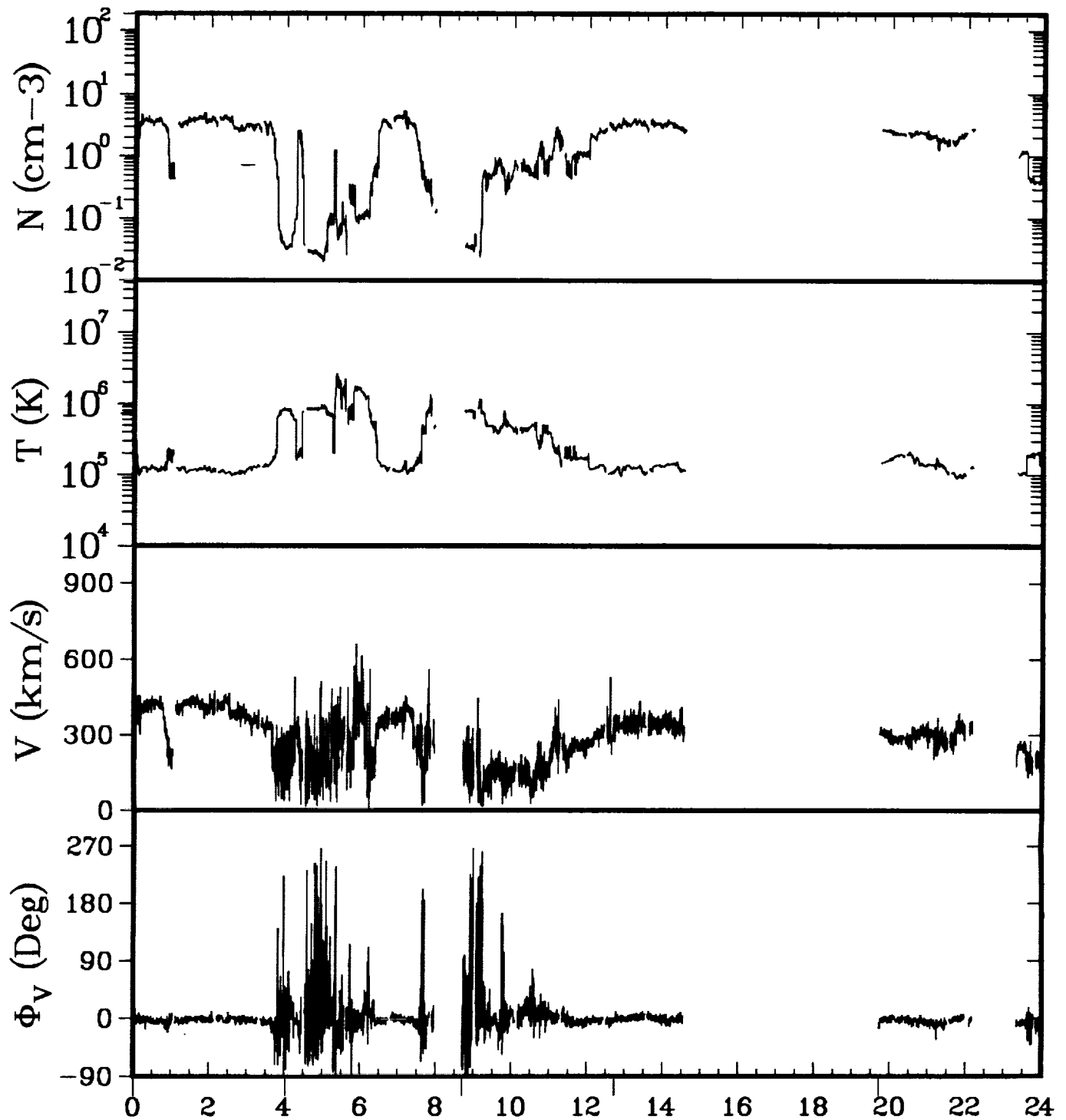

ISEE-3 ELECTRONS 03/07/83

GSEX	-186.4	-185.9	-185.4	-184.9	-184.1
Y	46.2	46.1	46.0	45.9	45.6
Z	-5.6	-5.5	-5.5	-5.4	-5.2
GSMY	41.4	44.1	46.1	45.9	41.8
Z	21.3	14.6	4.7	4.7	19.0

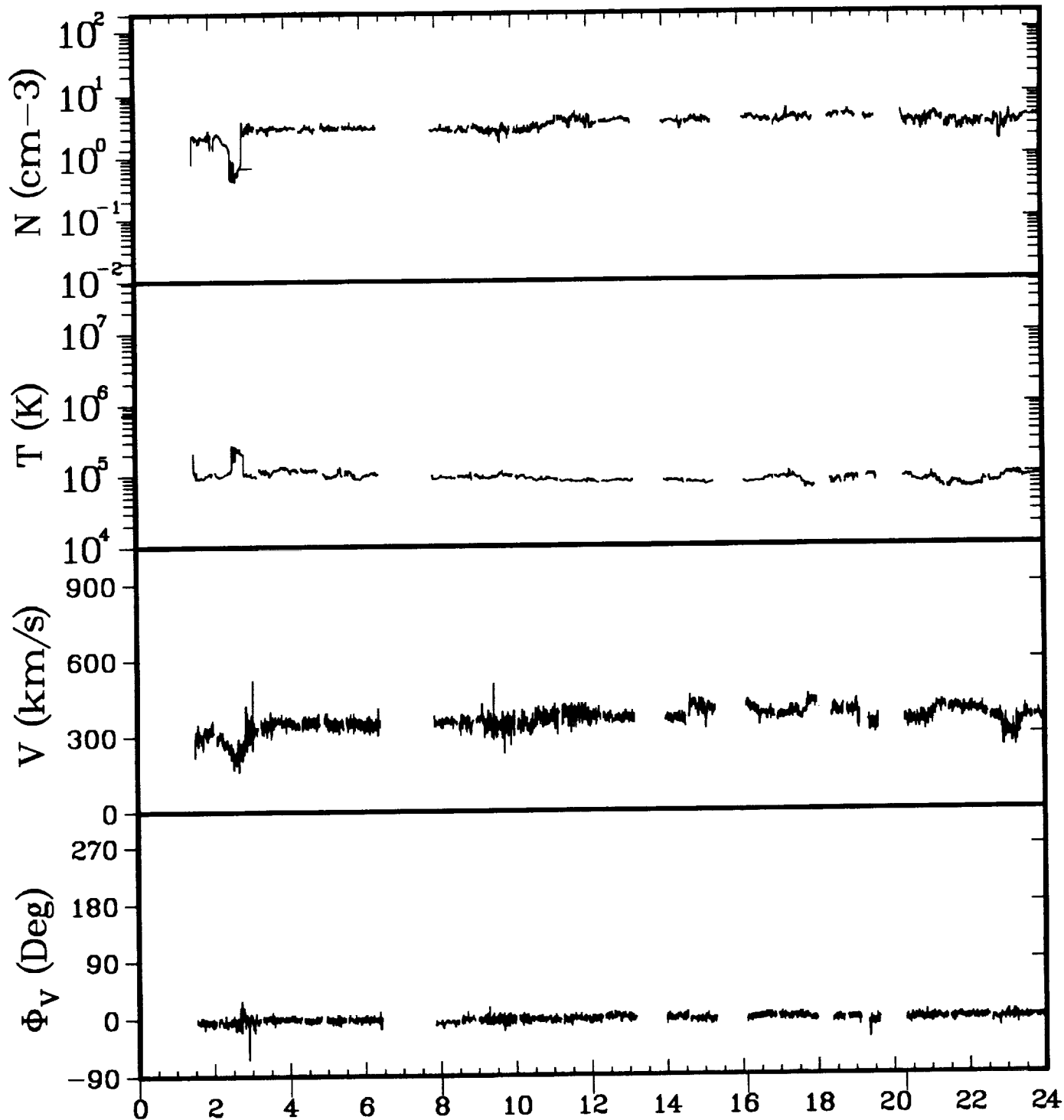

ISEE-3 ELECTRONS 03/08/83

GSEX	-183.6	-183.2	-182.7	-182.2	-181.7	-181.2
Y	45.5	45.4	45.2	45.1	44.9	44.7
Z	-5.2	-5.1	-5.0	-4.9	-4.9	-4.8
GSMY	40.5	43.2	45.1	45.1	43.7	40.4
Z	21.3	14.9	6.0	4.3	11.4	19.9

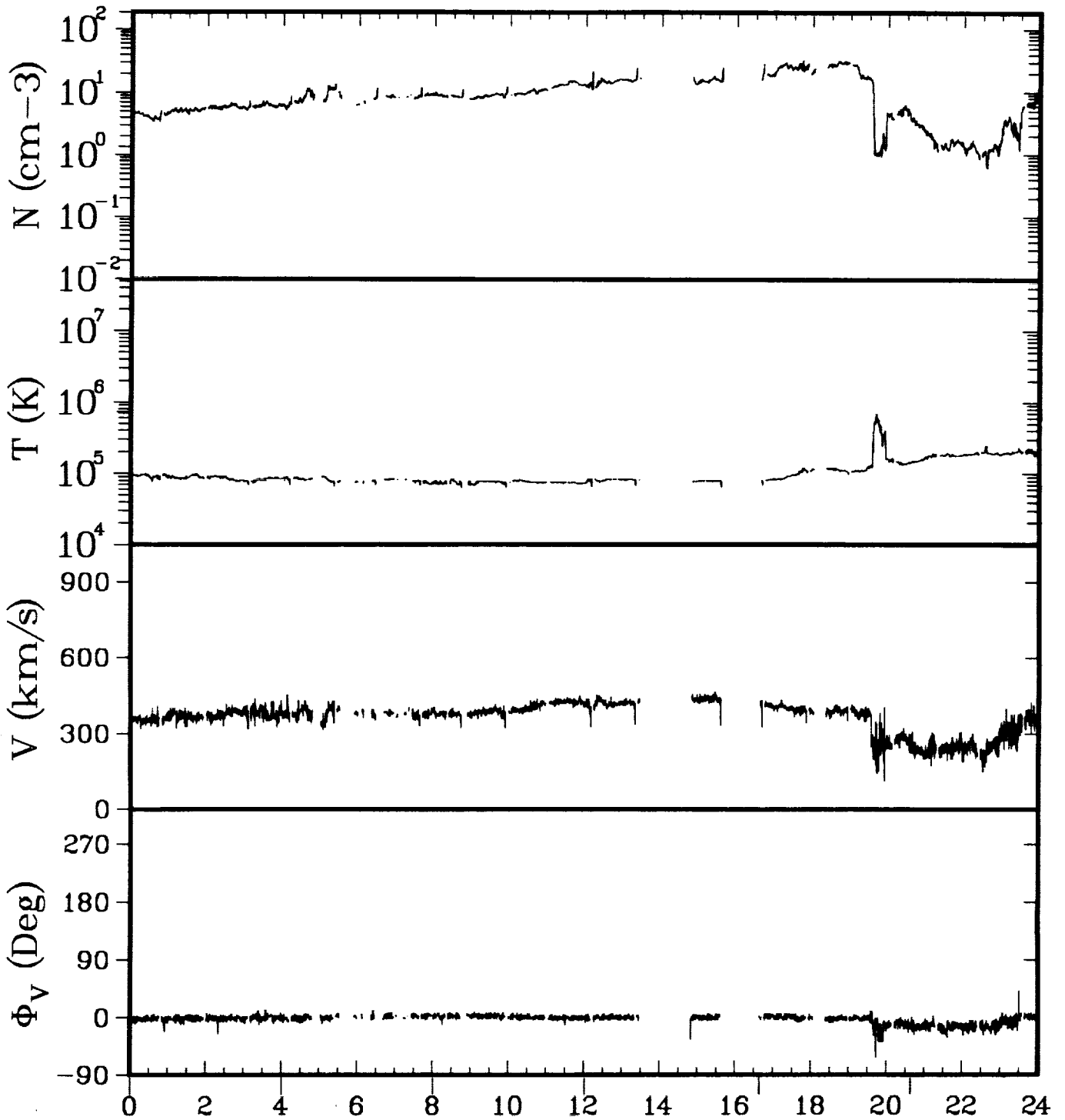

ISEE-3 ELECTRONS 03/09/83

GSEX	-180.8	-180.3	-179.8	-179.3	-178.7	-178.2
Y	44.6	44.4	44.3	44.1	43.9	43.7
Z	-4.7	-4.6	-4.6	-4.5	-4.4	-4.3
GSMY	39.5	42.1	44.1	44.1	42.2	39.0
Z	21.2	14.9	6.3	4.7	12.8	20.2

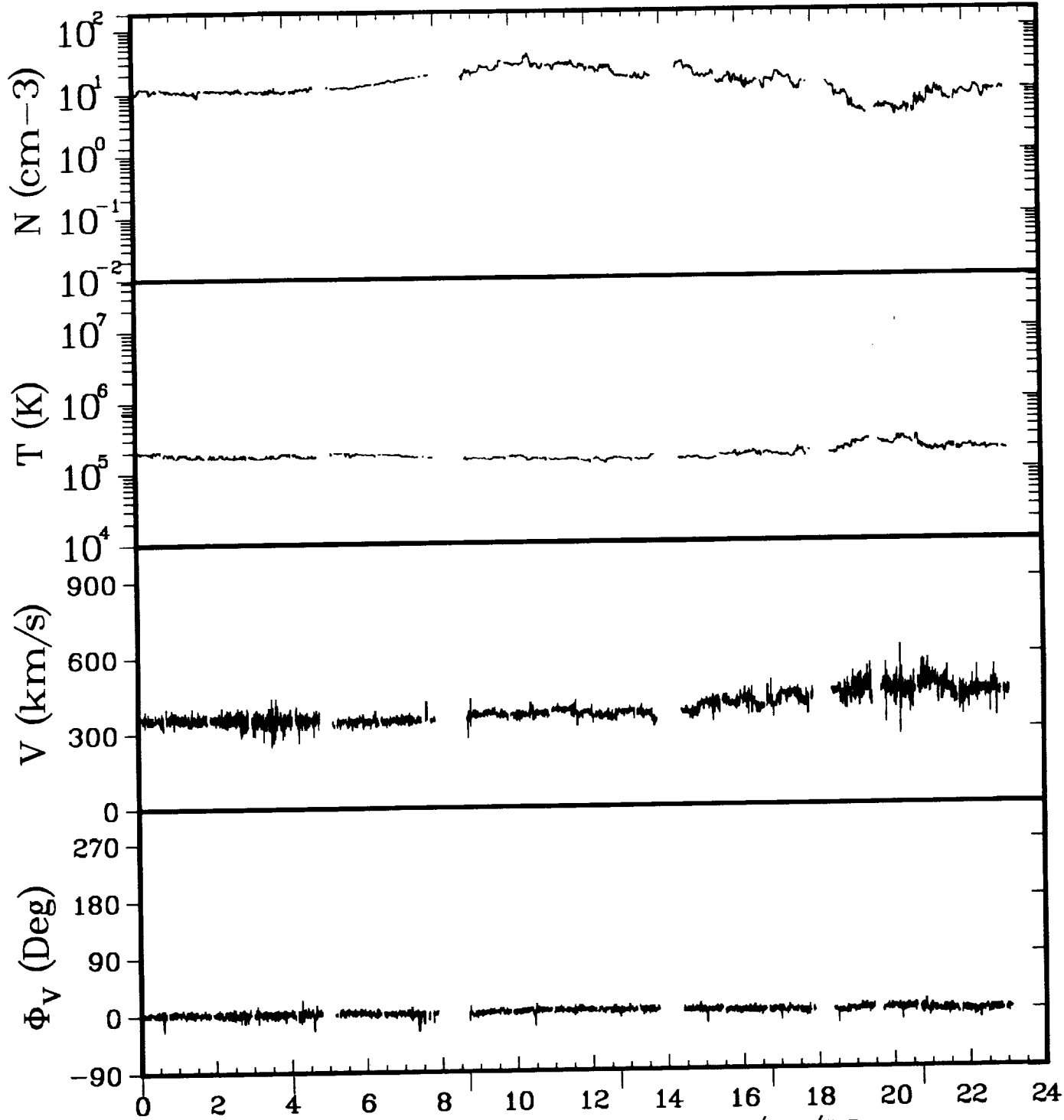

ISEE-3 ELECTRONS 03/10/83

GSEX	-177.8	-177.3	-176.7	-176.2	-175.7	-175.2
Y	43.6	43.4	43.1	42.9	42.7	42.5
Z	-4.2	-4.2	-4.1	-4.0	-3.9	-3.8
GSMY	38.4	41.0	43.0	42.8	40.9	37.7
Z	21.1	14.9	5.6	5.6	13.1	20.1

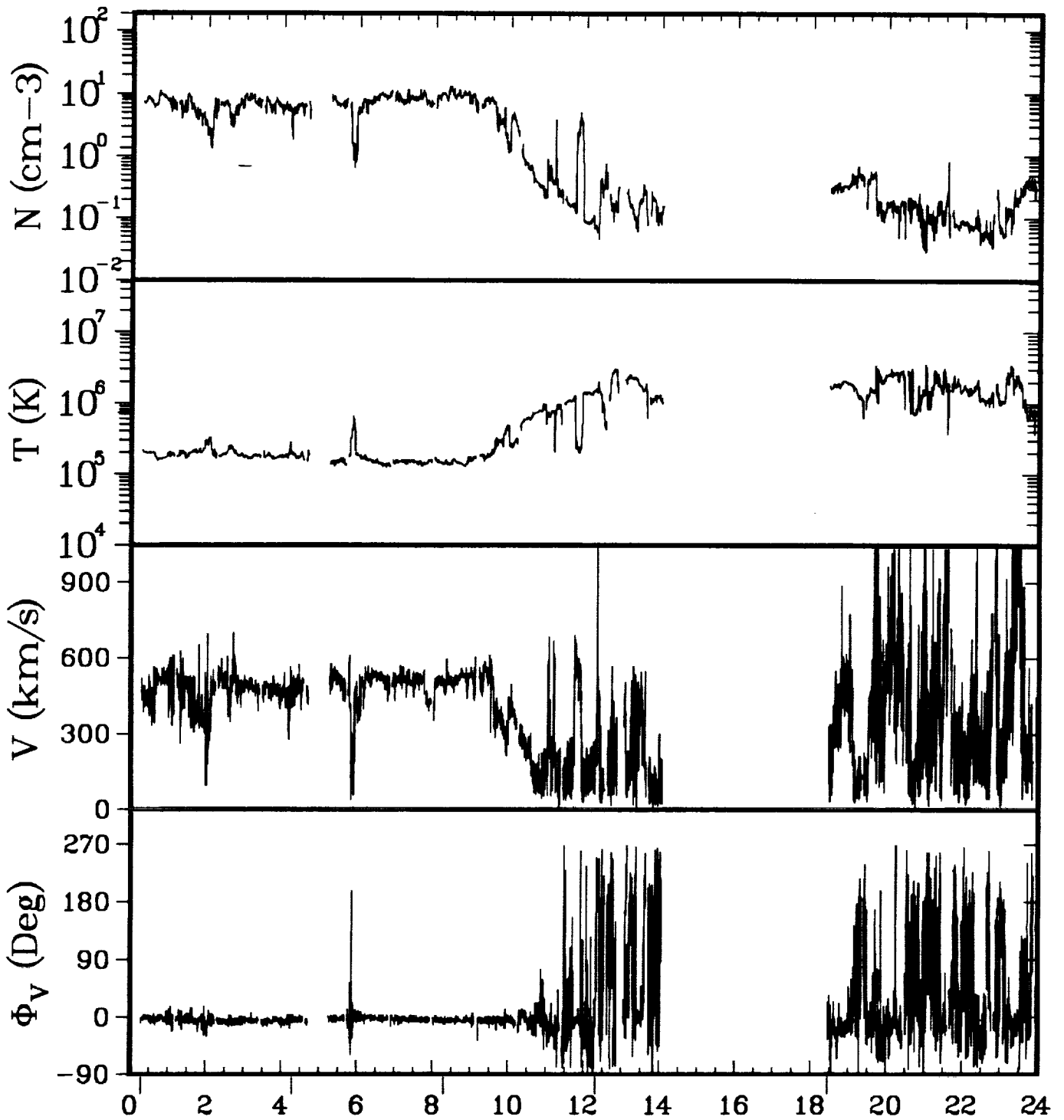

ISEE-3 ELECTRONS 03/11/83

GSEX	-174.7	-174.2	-173.6	-173.1	-172.3
Y	42.3	42.1	41.9	41.7	41.3
Z	-3.8	-3.7	-3.6	-3.5	-3.4
GSMY	37.2	39.8	41.6	41.5	38.0
Z	20.6	14.2	6.3	5.5	16.5

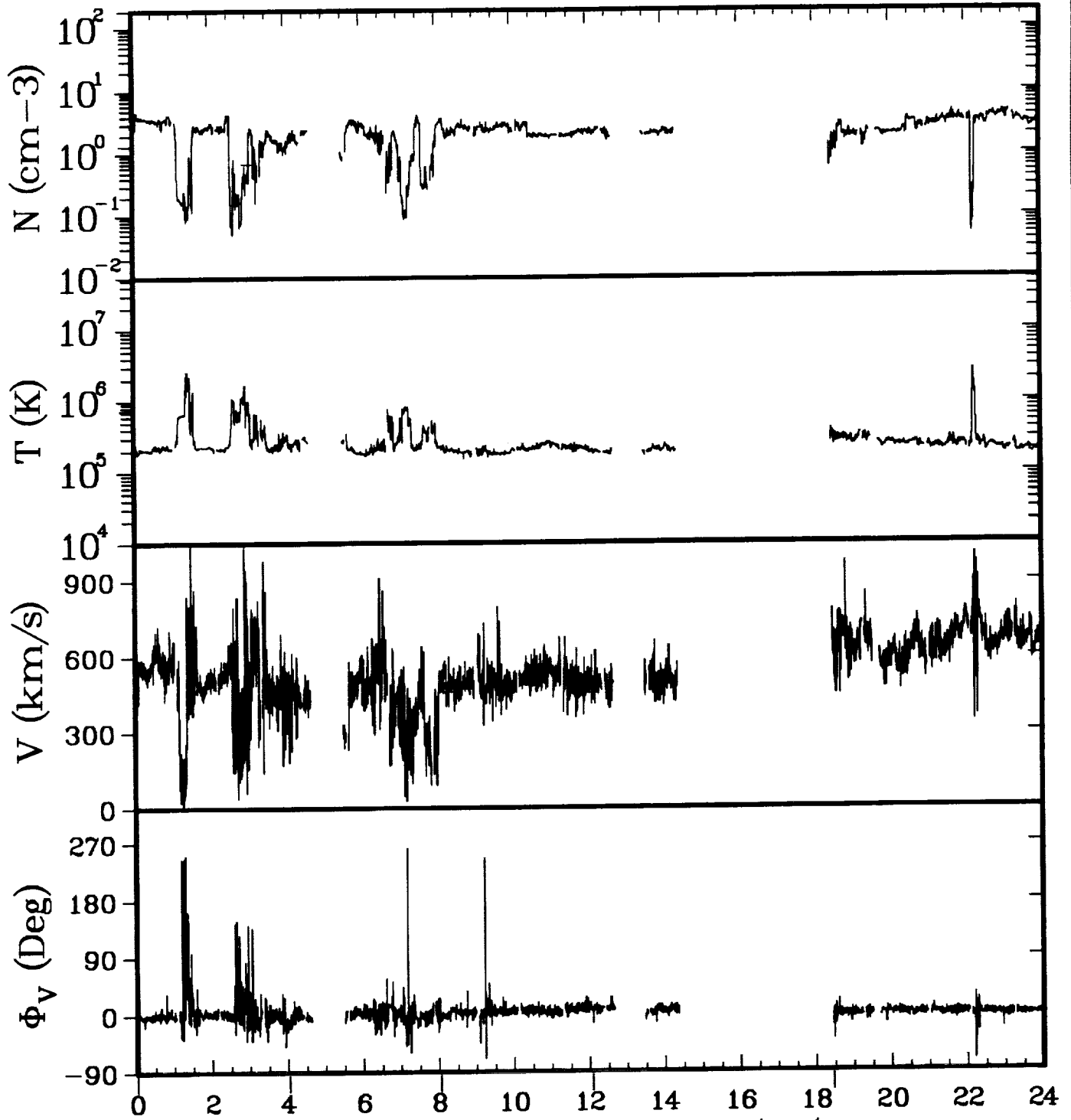

ISEE-3 ELECTRONS 03/12/83

GSEX	-171.5	-171.0	-170.4	-169.9	-169.0
Y	41.0	40.7	40.5	40.2	39.8
Z	-3.3	-3.2	-3.1	-3.0	-2.9
GSMY	35.6	38.1	40.0	40.0	36.4
Z	20.5	14.7	6.9	5.5	16.3

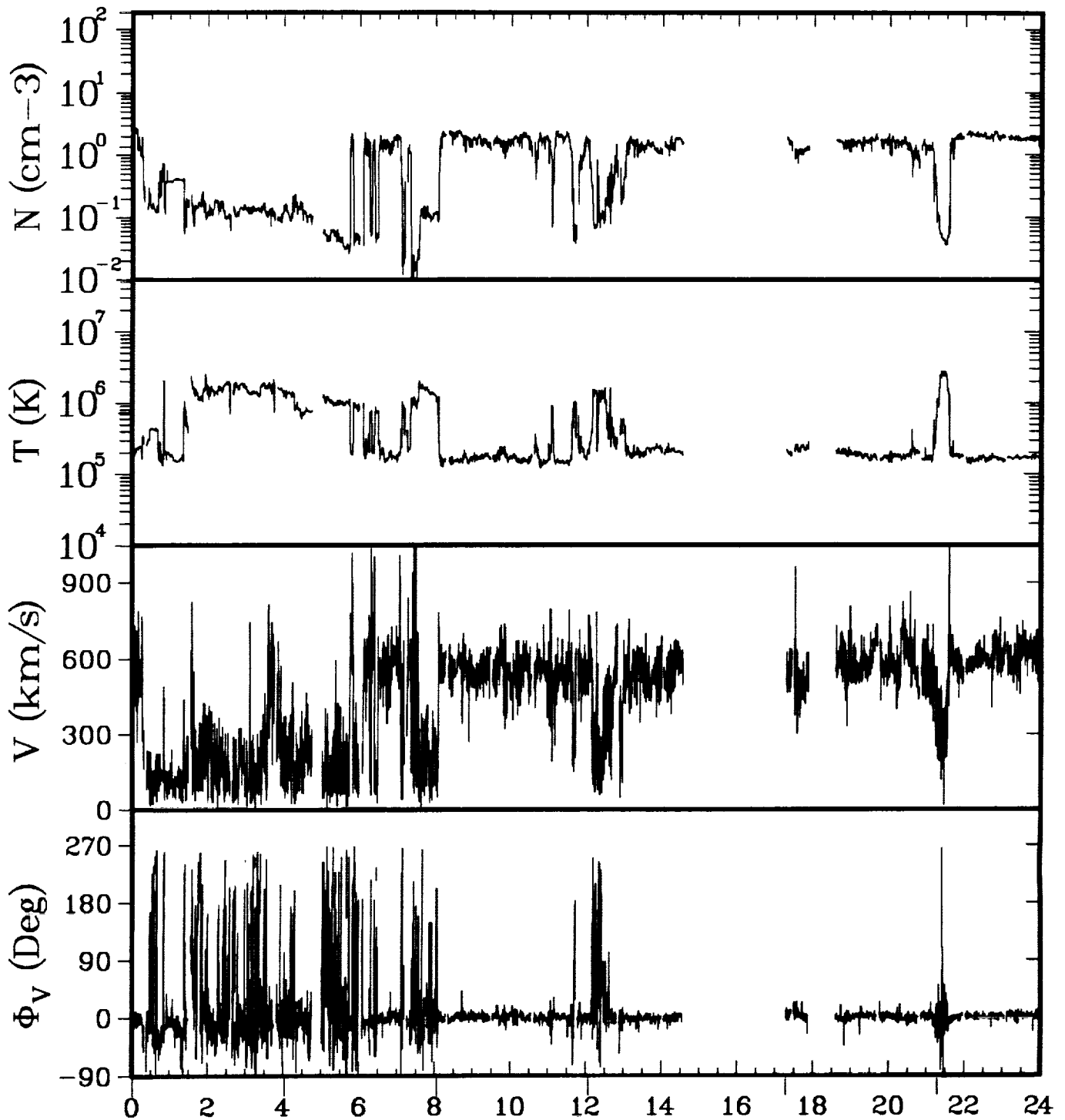

ISEE-3 ELECTRONS 03/13/83

GSEX	-168.2	-167.7	-167.1	-166.5	-165.8	-165.2
Y	39.4	39.1	38.9	38.6	38.2	37.9
Z	-2.8	-2.7	-2.6	-2.5	-2.4	-2.3
GSMY	34.1	36.5	38.3	38.2	35.6	32.6
Z	20.0	14.5	7.0	5.7	13.9	19.4

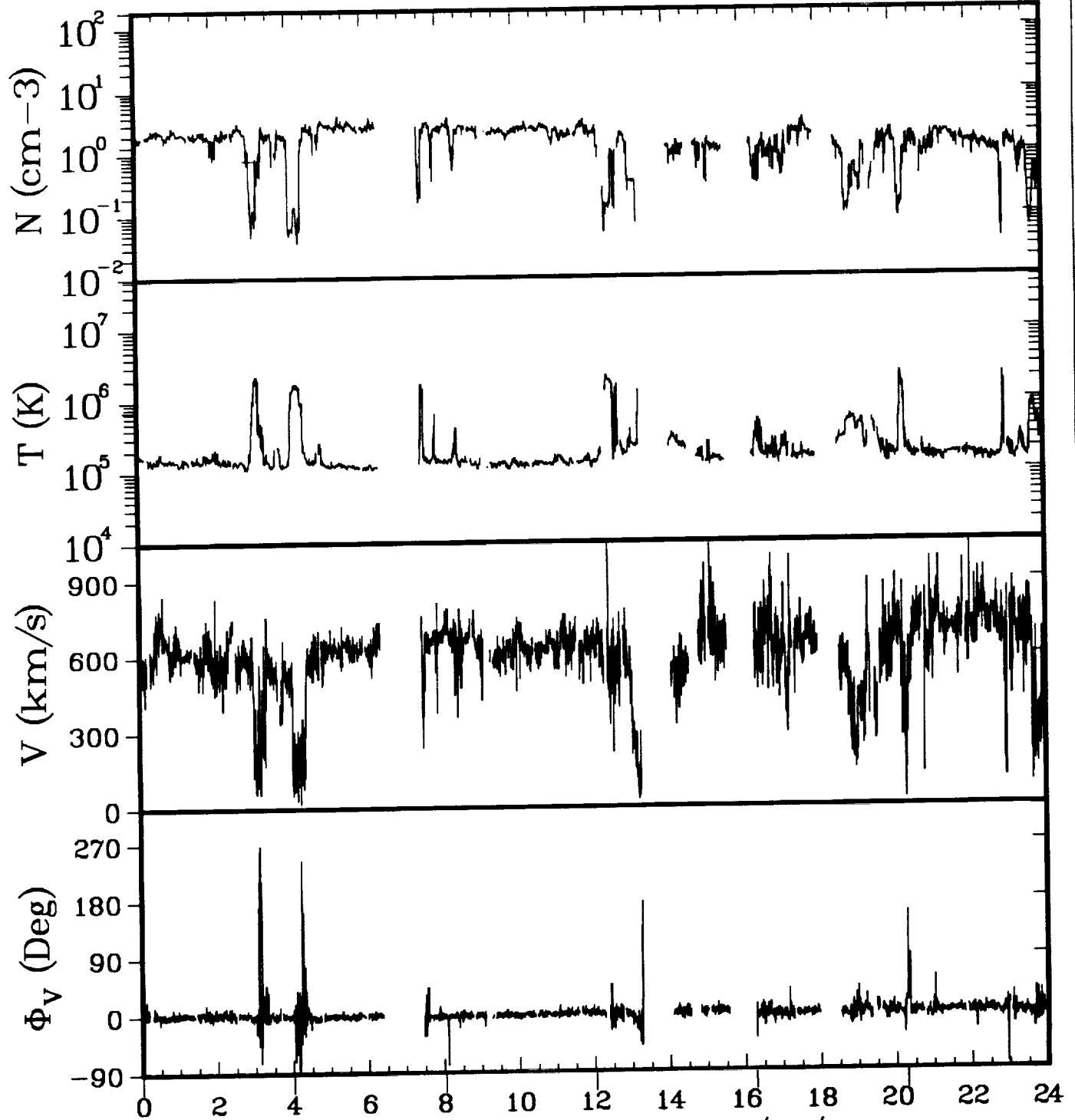

ISEE-3 ELECTRONS 03/14/83

GSEX	-164.8	-164.2	-163.6	-163.0	-162.3	-161.7
Y	37.7	37.4	37.0	36.7	36.4	36.0
Z	-2.3	-2.2	-2.1	-2.0	-1.9	-1.8
GSMY	32.3	34.6	36.4	36.3	34.5	31.3
Z	19.5	14.2	7.1	5.8	11.8	18.0

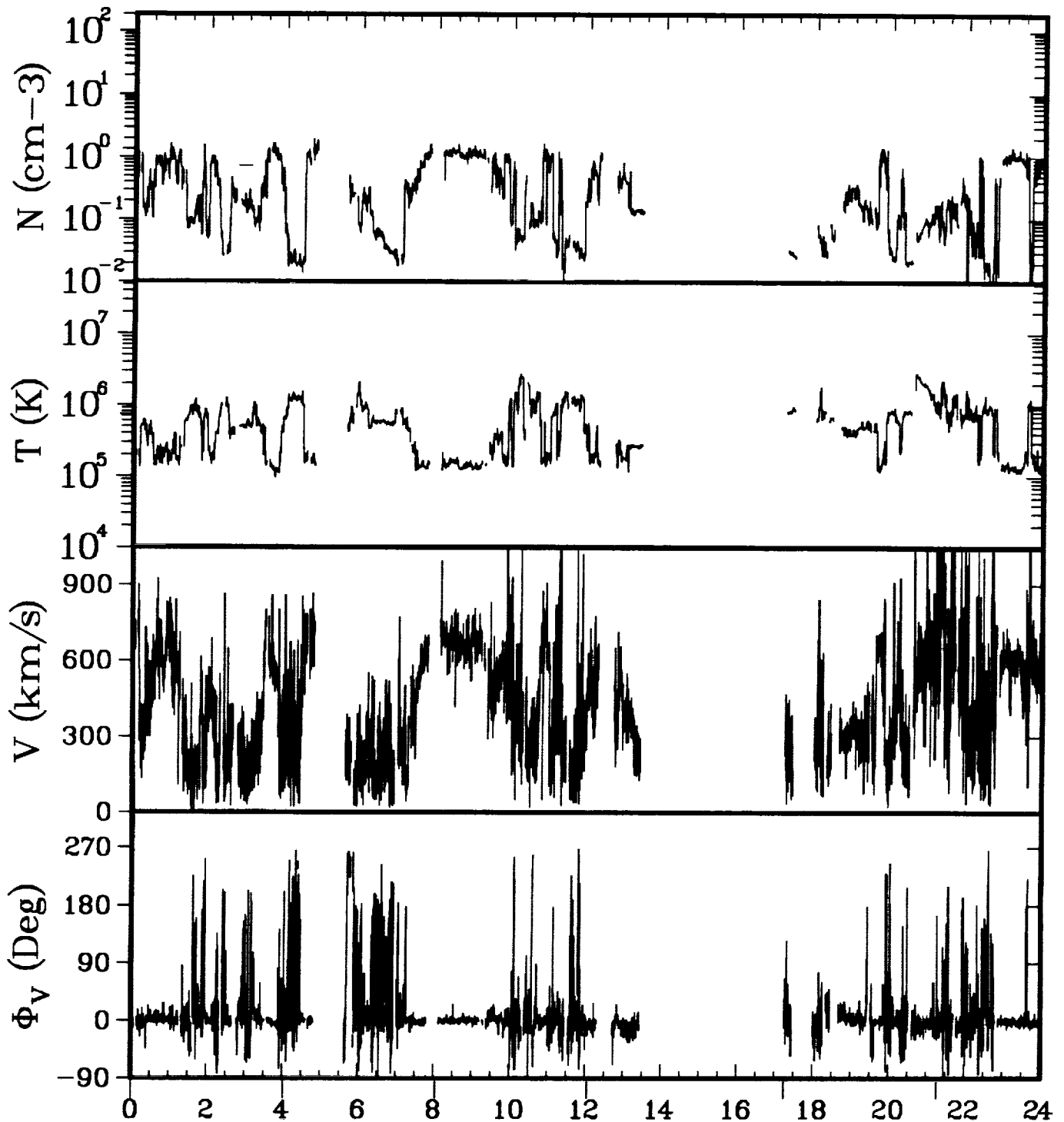

ISEE-3 ELECTRONS 03/15/83

GSEX	-161.2	-160.5	-159.9	-159.3	-158.5	-157.8
Y	35.7	35.4	35.0	34.6	34.2	33.8
Z	-1.7	-1.6	-1.6	-1.5	-1.4	-1.3
GSMY	30.4	32.6	34.3	34.2	31.6	28.6
Z	18.8	13.8	7.1	5.9	13.1	18.0

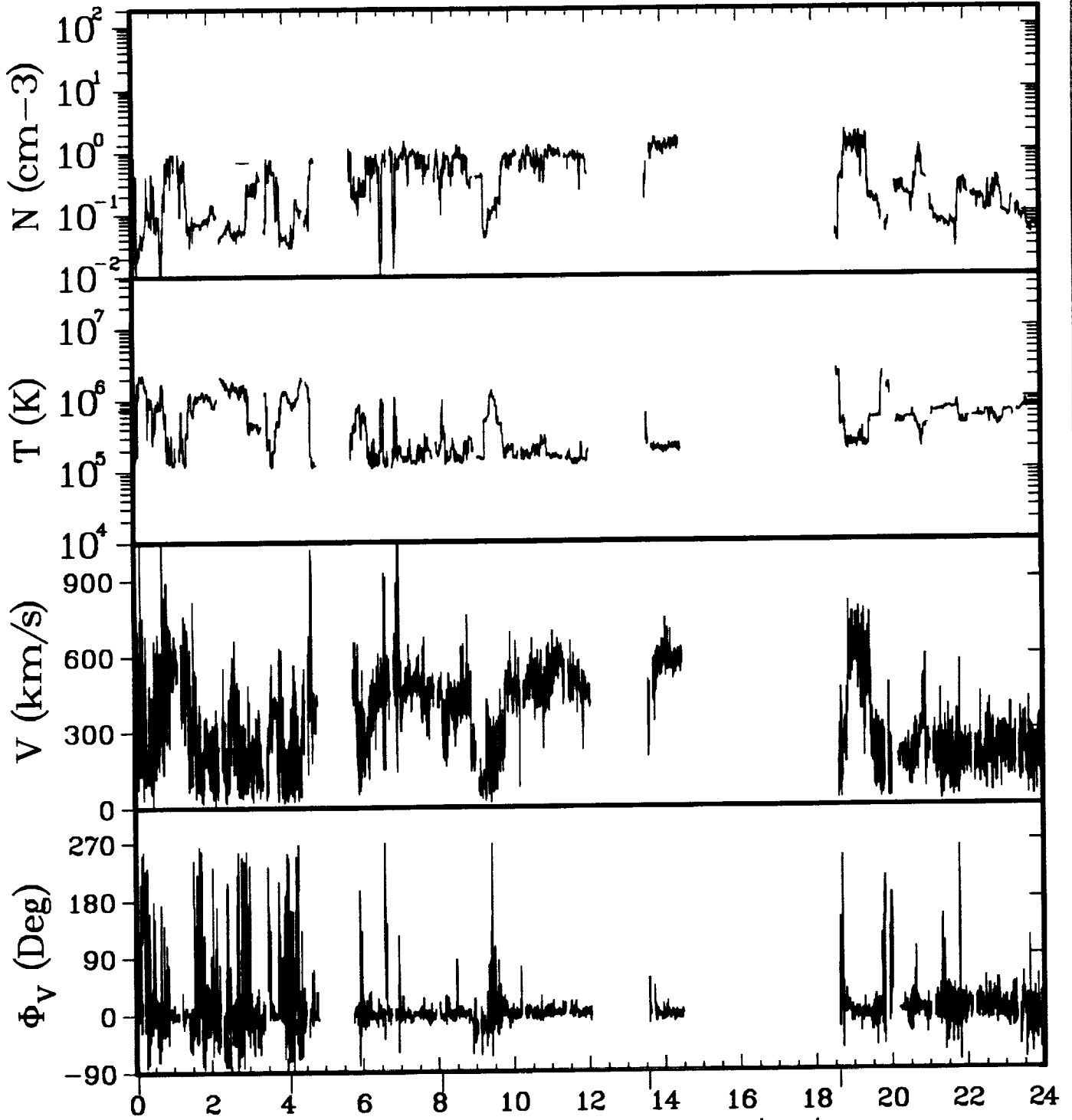

ISEE-3 ELECTRONS 03/16/83

GSEX	-157.4	-156.7	-156.1	-155.2	-154.4
Y	33.5	33.1	32.7	32.2	31.7
Z	-1.2	-1.1	-1.0	-0.9	-0.8
GSMY	28.3	30.4	32.0	31.4	28.1
Z	18.0	13.3	7.0	7.2	14.6

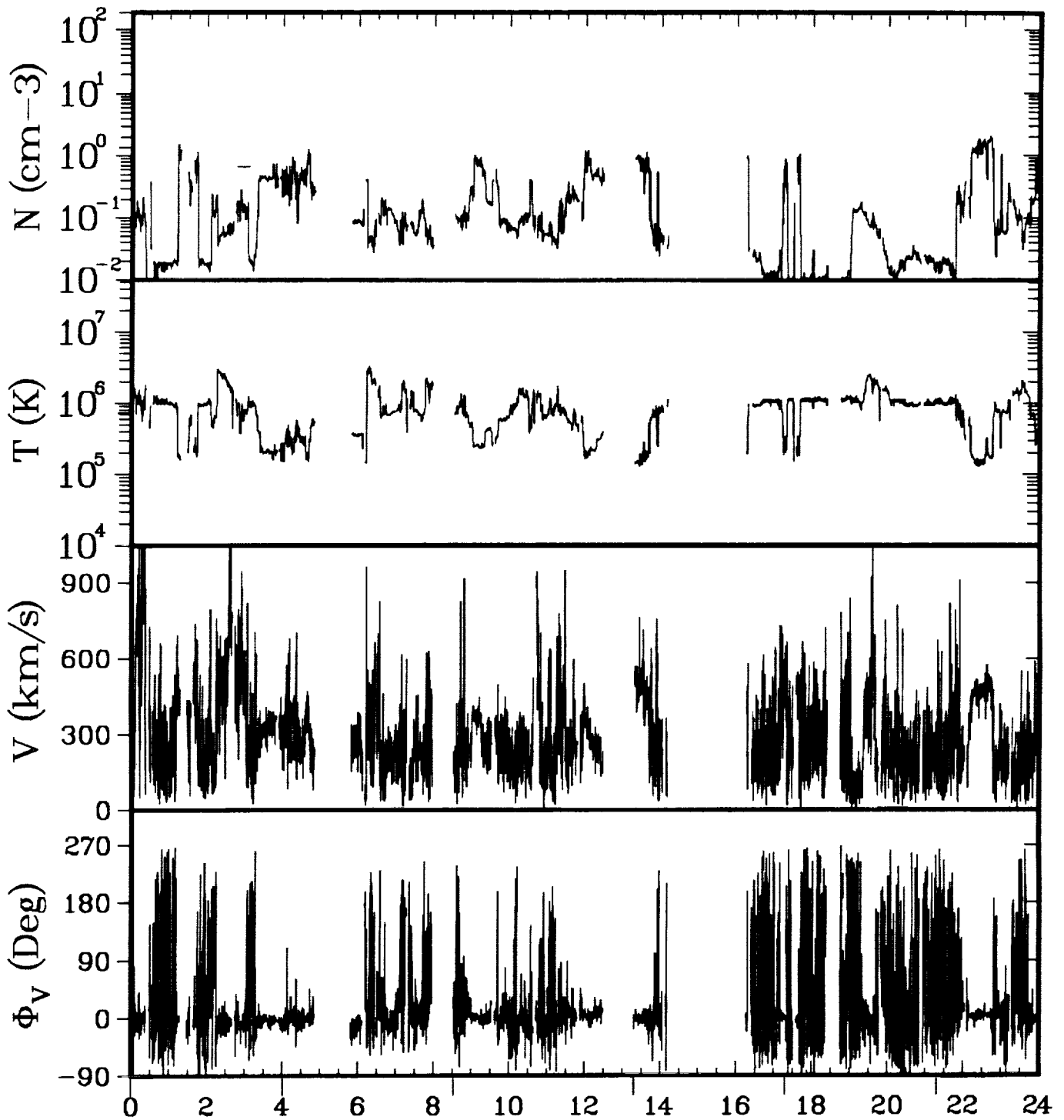

ISEE-3 ELECTRONS 03/17/83

GSEX	-153.5	-152.8	-152.0	-151.2	-150.5	-149.8
Y	31.1	30.7	30.2	29.6	29.2	28.7
Z	-0.7	-0.6	-0.5	-0.4	-0.3	-0.2
GSMY	26.0	27.9	29.5	28.8	26.6	23.8
Z	17.1	12.8	6.5	6.9	12.1	16.1

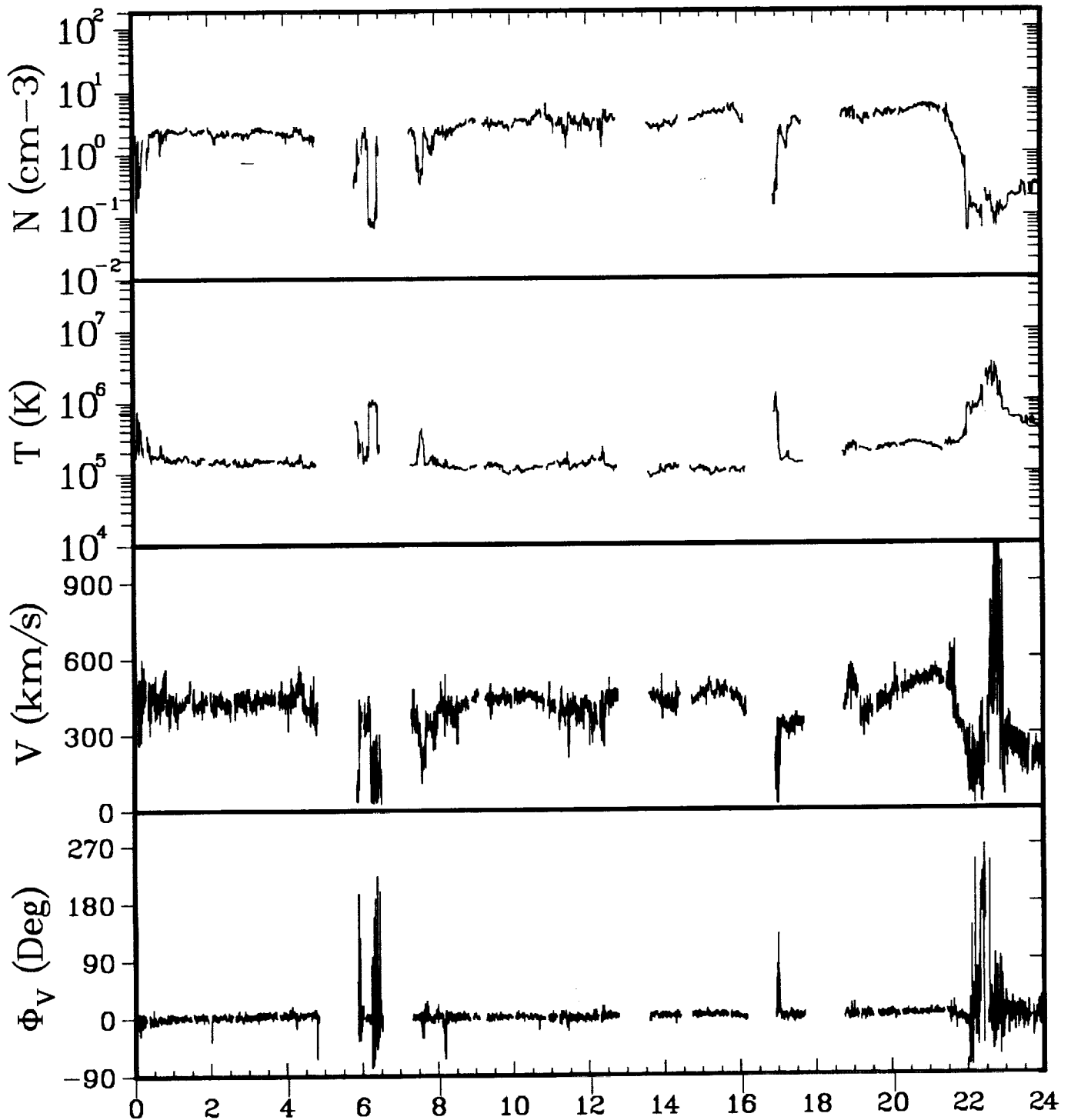

ISEE-3 ELECTRONS 03/18/83

GSEX	-149.3	-148.6	-147.9	-147.1	-146.4	-145.7
Y	28.4	27.9	27.5	27.0	26.5	26.0
Z	-0.1	0.0	0.0	0.1	0.2	0.3
GSMY	23.5	25.2	26.6	26.3	24.6	21.8
Z	16.0	12.0	6.8	5.9	9.8	14.2

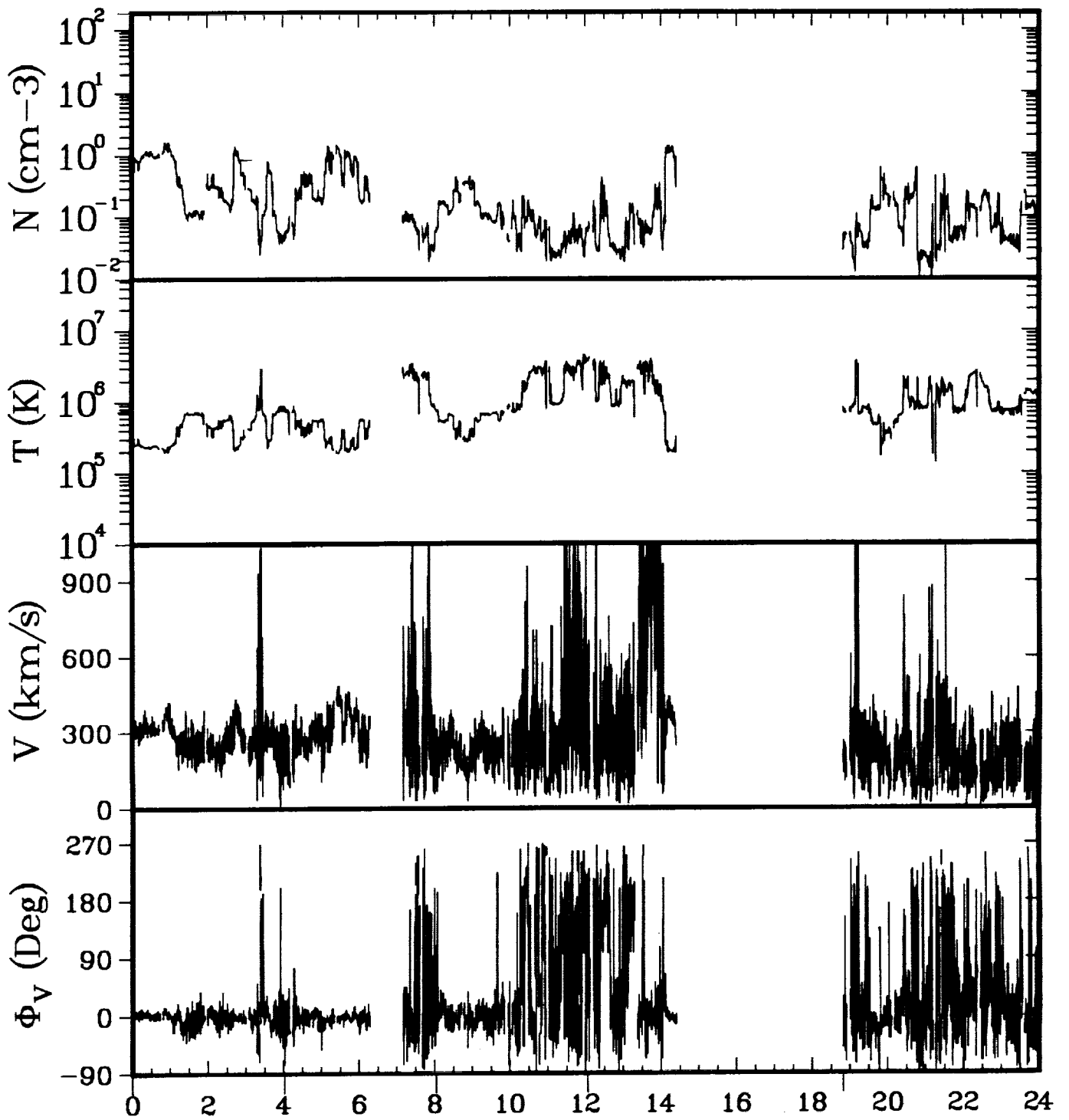

ISEE-3 ELECTRONS 03/19/83

GSEX	-144.9	-144.2	-143.4	-142.6	-141.3
Y	25.5	25.0	24.4	23.9	23.0
Z	0.4	0.5	0.6	0.7	0.8
GSMY	20.7	22.3	23.5	23.2	19.6
Z	14.8	11.3	6.6	5.8	12.1

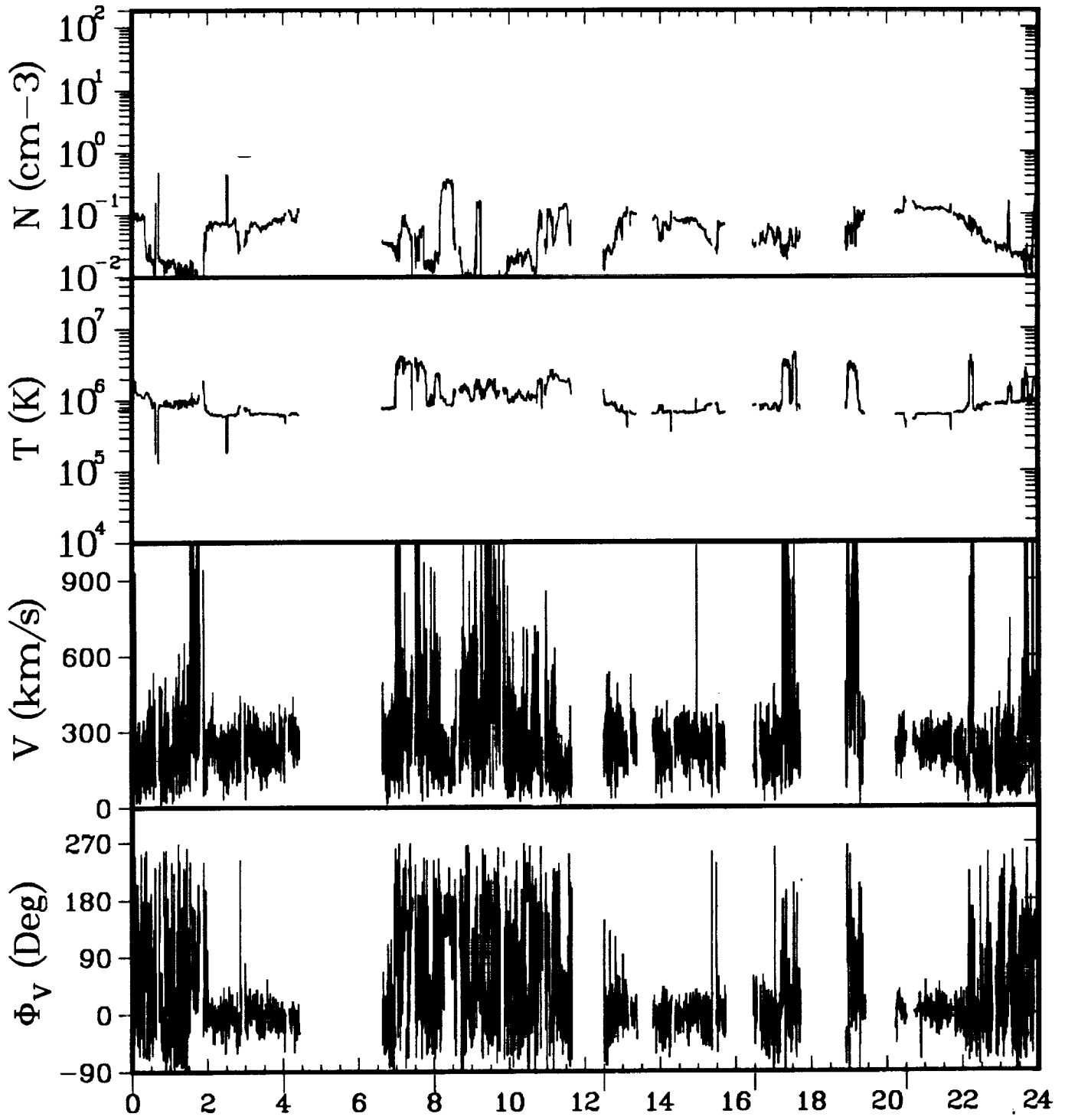

ISEE-3 ELECTRONS 03/20/83

GSEX	-140.3	-139.5	-138.7	-137.8	-136.9	-136.1
Y	22.3	21.7	21.1	20.5	19.9	19.3
Z	1.0	1.0	1.1	1.2	1.3	1.4
GSMY	17.8	19.1	20.2	19.7	17.8	15.3
Z	13.4	10.4	6.4	5.8	8.9	11.8

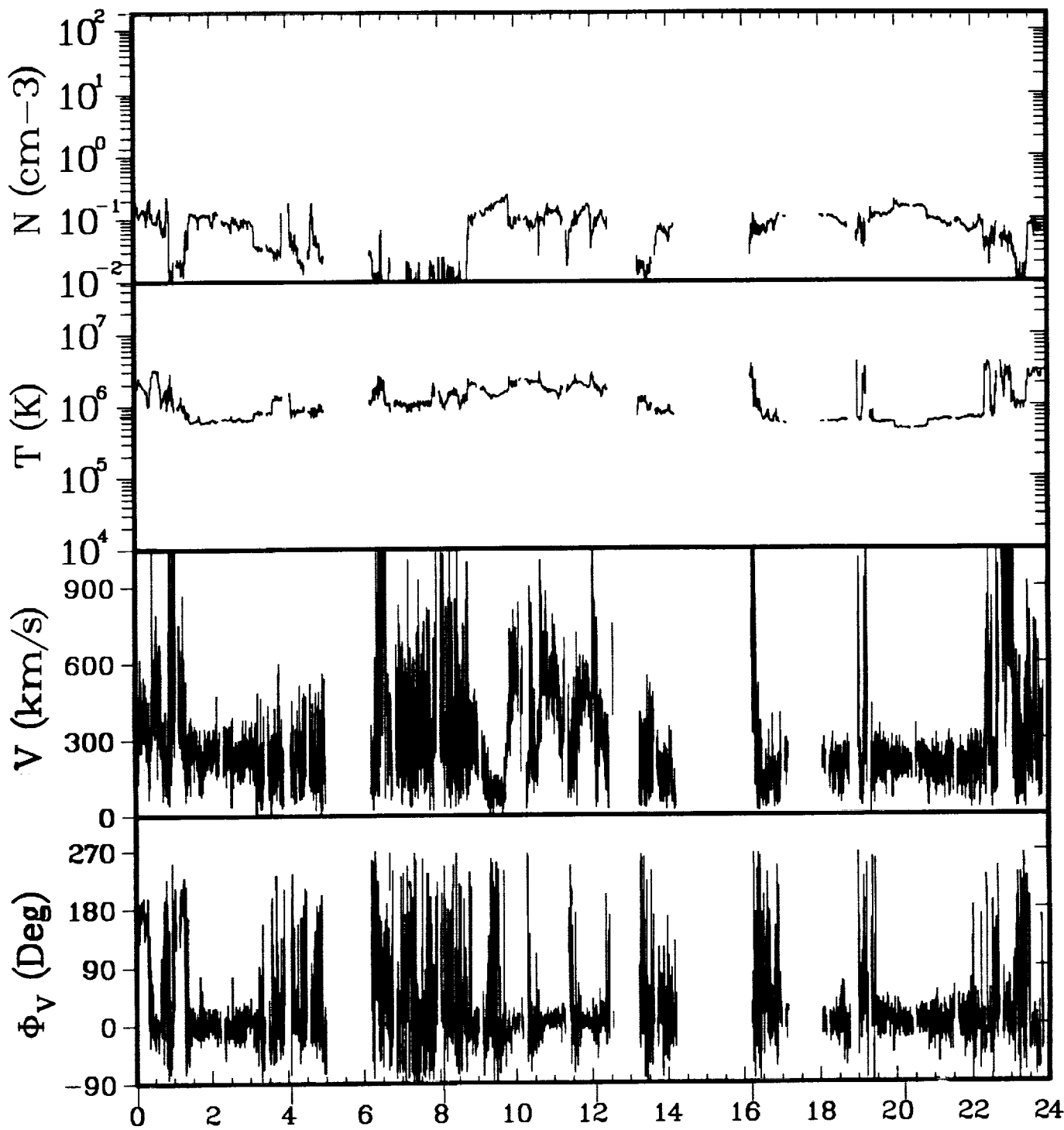

ISEE-3 ELECTRONS 03/21/83

GSEX	-135.3	-134.5	-133.6	-132.7	-131.8	-130.9
Y	18.7	18.1	17.5	16.9	16.2	15.6
Z	1.5	1.6	1.7	1.8	1.9	1.9
GSMY	14.6	15.7	16.5	16.1	14.4	12.0
Z	11.9	9.2	5.9	5.3	7.7	10.1

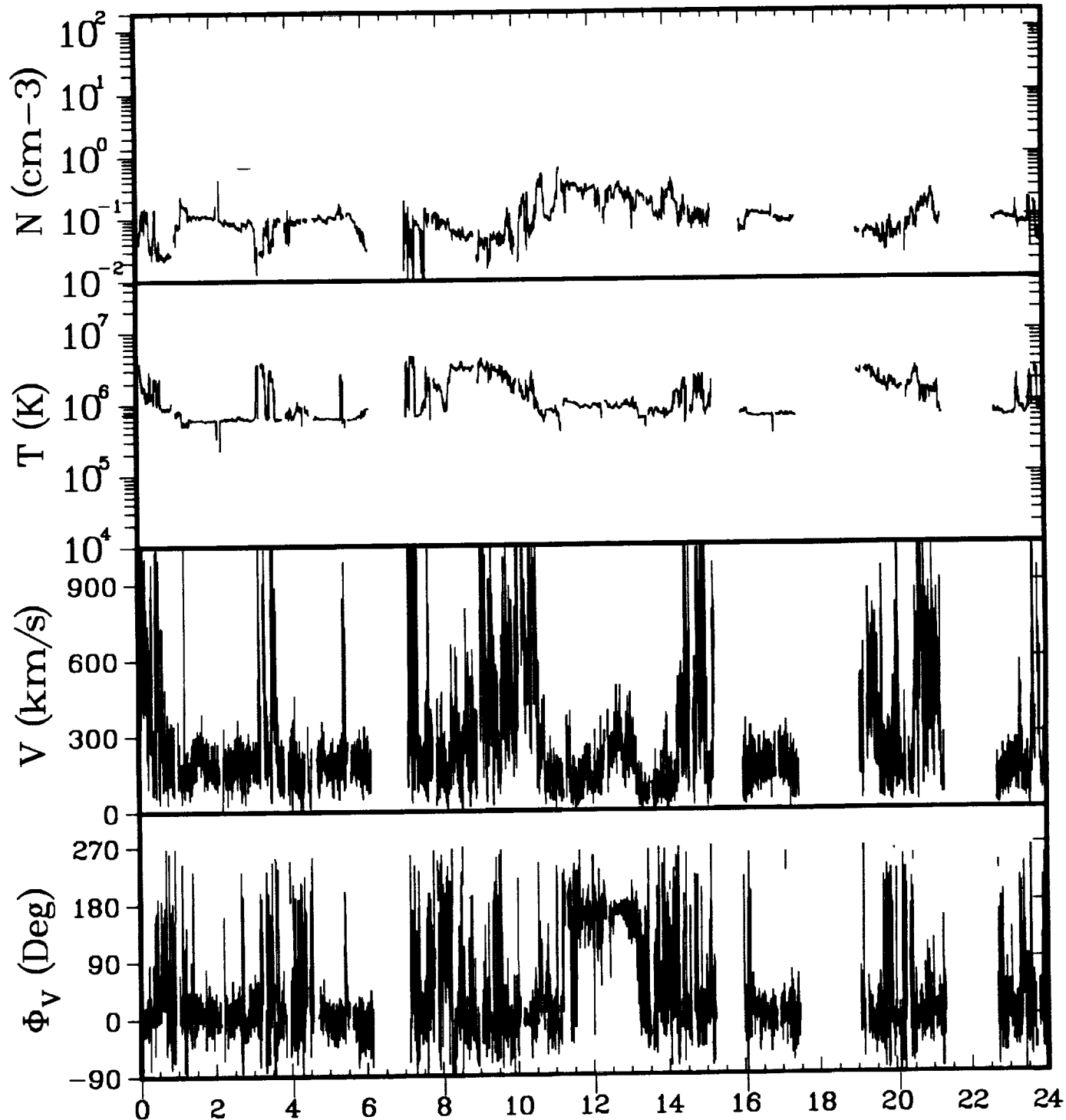

ISEE-3 ELECTRONS 03/22/83

GSEX	-130.0	-129.1	-128.2	-127.2	-126.2	-125.3
Y	14.9	14.3	13.6	12.9	12.2	11.5
Z	2.0	2.1	2.2	2.3	2.4	2.5
GSMY	11.1	12.0	12.6	12.1	10.5	8.4
Z	10.1	8.1	5.5	5.0	6.7	8.3

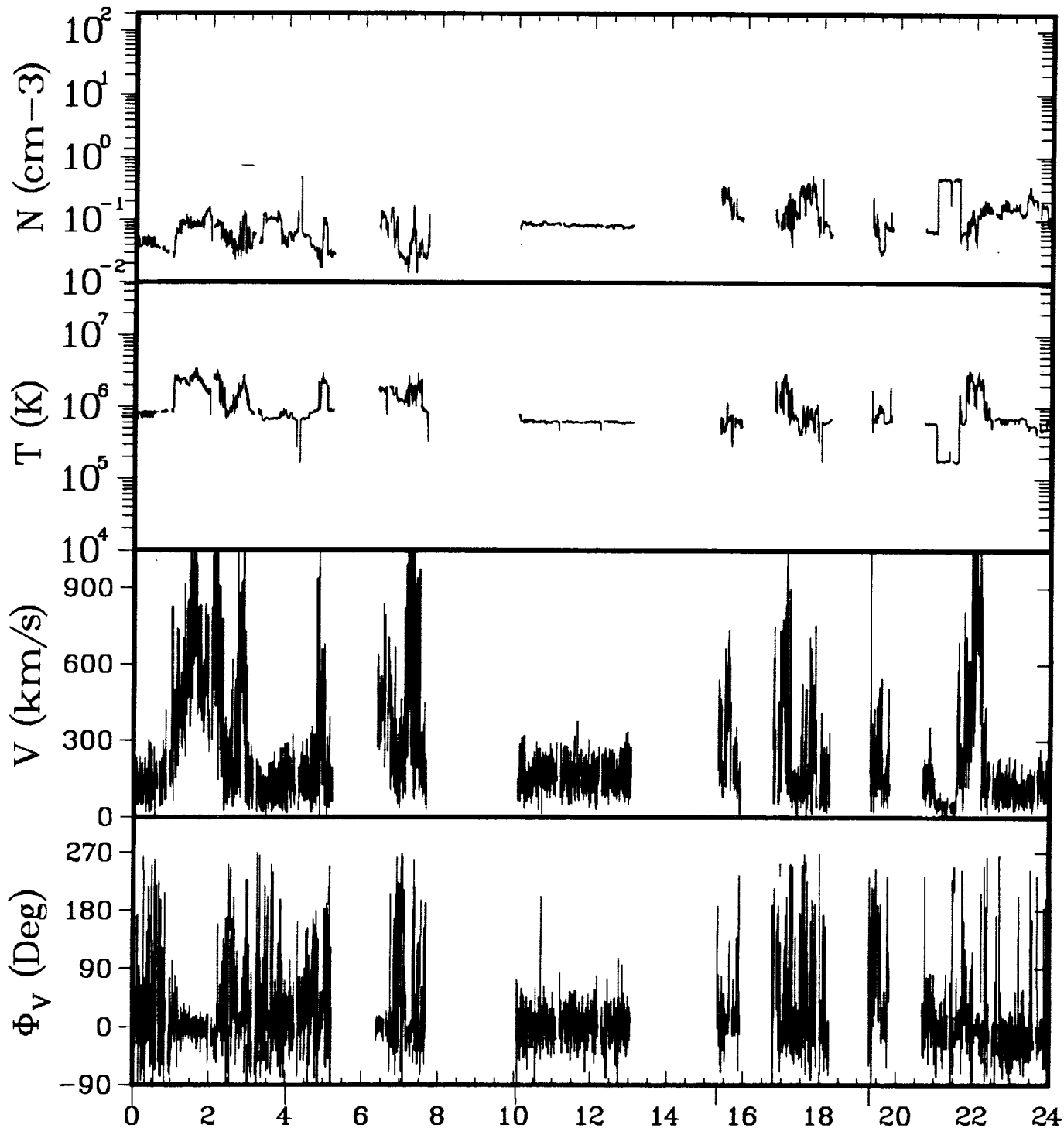

ISEE-3 ELECTRONS 03/23/83

GSEX	-124.3	-123.3	-121.8	-120.4	-119.3
Y	10.8	10.1	9.0	8.0	7.3
Z	2.6	2.6	2.8	2.9	3.0
GSMY	7.5	8.0	8.2	6.6	4.7
Z	8.2	6.7	4.5	5.3	6.3

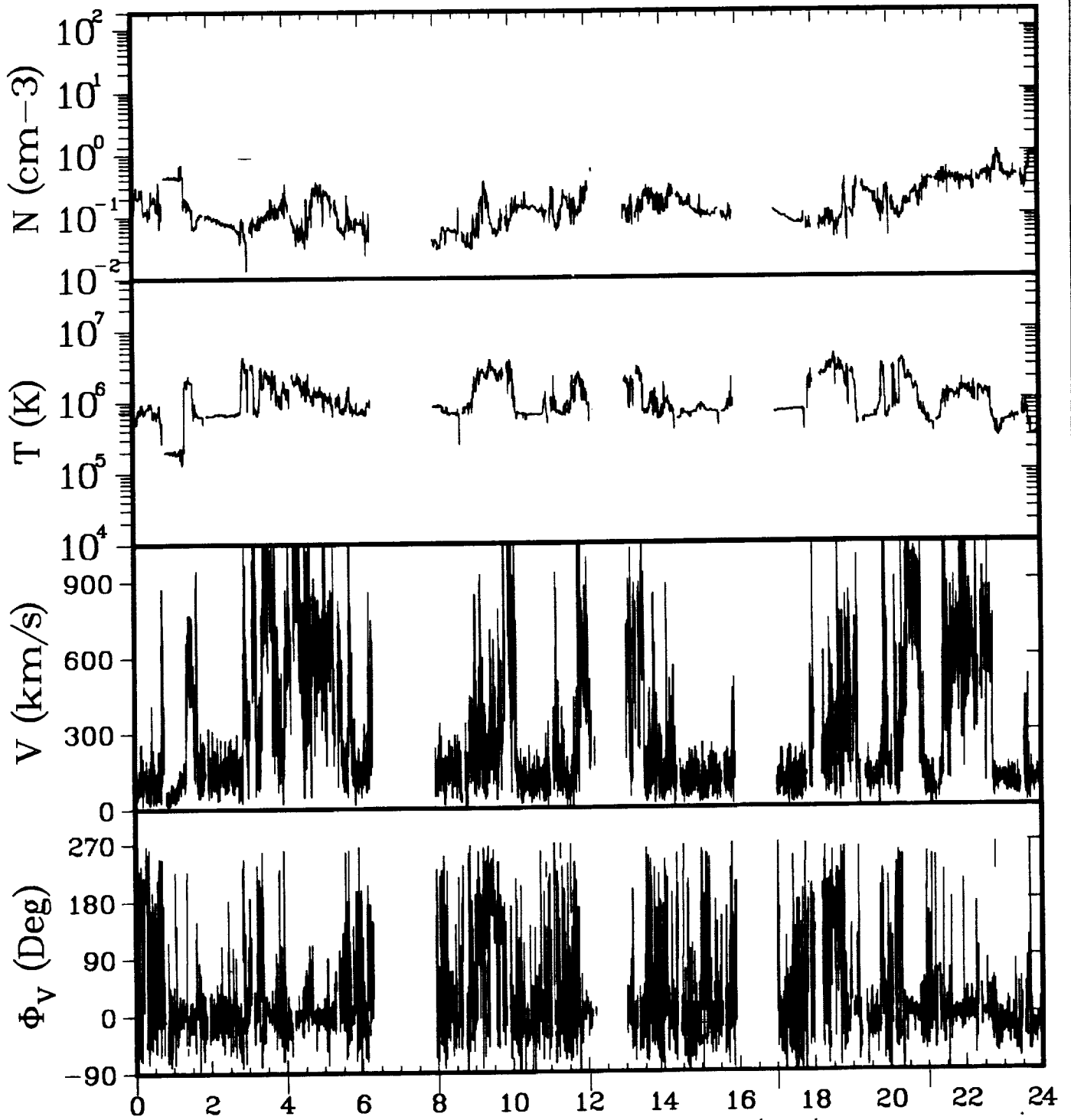

ISEE-3 ELECTRONS 03/24/83

GSEX	-118.1	-117.0	-115.9	-114.7	-113.3	-112.1
Y	6.4	5.6	4.8	4.0	3.1	2.3
Z	3.1	3.1	3.2	3.3	3.4	3.5
GSMY	3.5	3.7	3.9	3.2	1.4	-0.1
Z	6.1	5.3	4.3	4.1	4.4	4.1

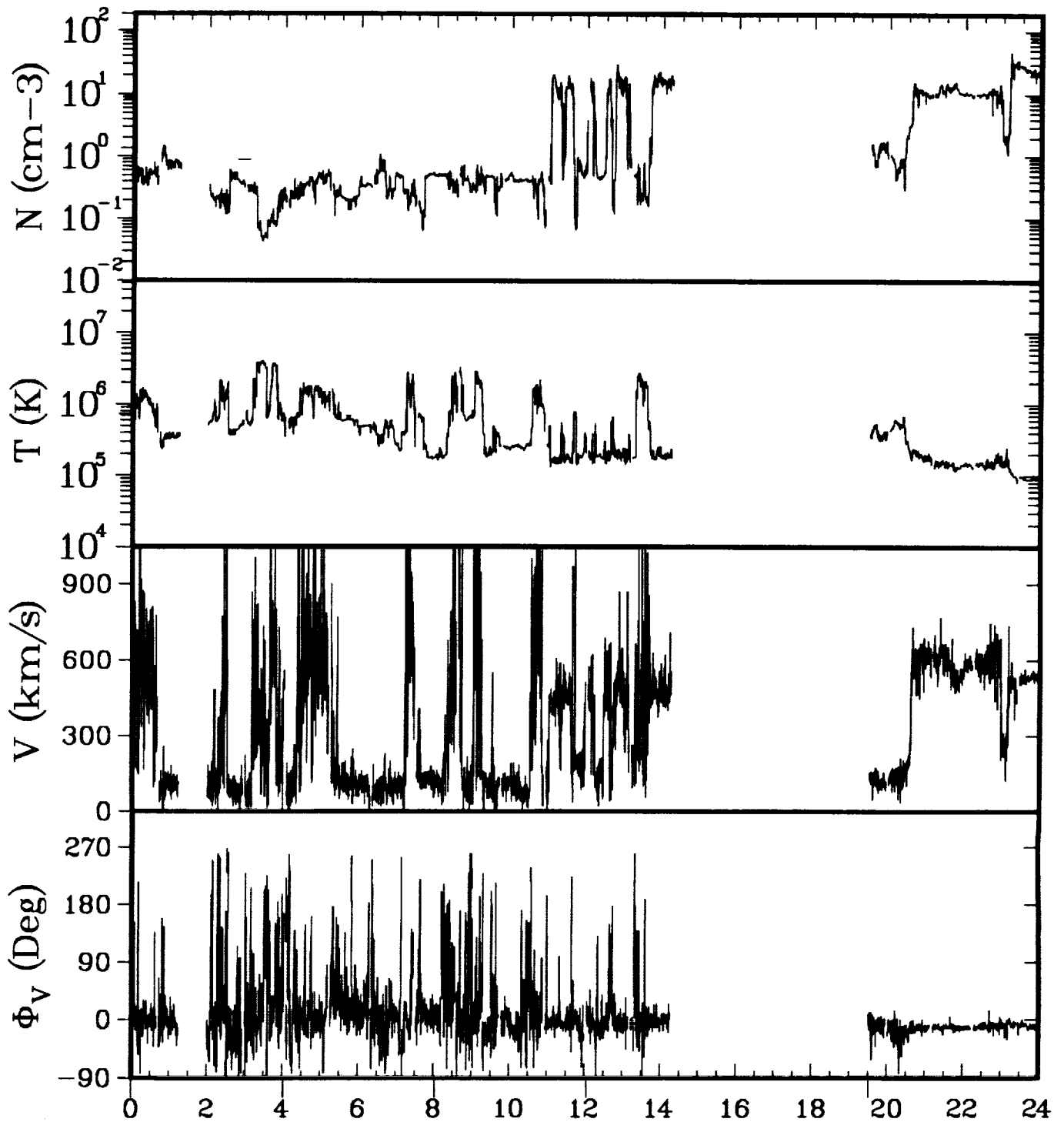

ISEE-3 ELECTRONS 03/25/83

GSEX	-111.2	-110.0	-108.8	-107.6	-105.2
Y	1.6	0.8	0.0	-0.8	-2.4
Z	3.5	3.6	3.7	3.8	3.9
GSMY	-0.7	-0.8	-0.9	-1.6	-4.1
Z	3.9	3.6	3.6	3.5	2.1

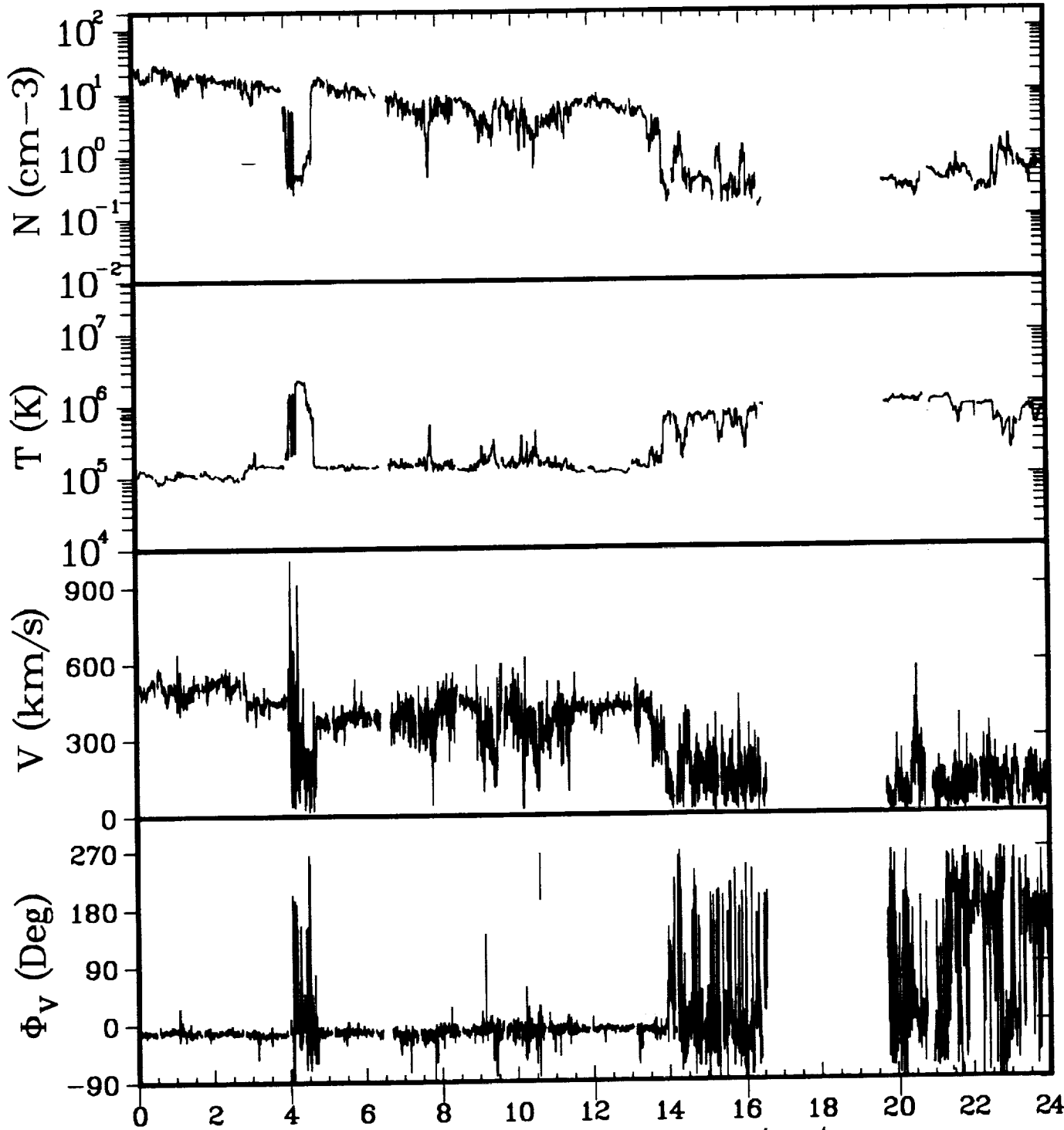

ISEE-3 ELECTRONS 03/26/83

GSEX	-103.7	-102.4	-101.0	-99.6	-98.2	-96.8
Y	-3.4	-4.2	-5.1	-6.0	-6.9	-7.8
Z	4.0	4.1	4.1	4.2	4.3	4.3
GSMY	-5.0	-5.6	-6.0	-6.7	-8.0	-8.9
Z	1.4	1.8	2.7	2.8	1.5	-0.5

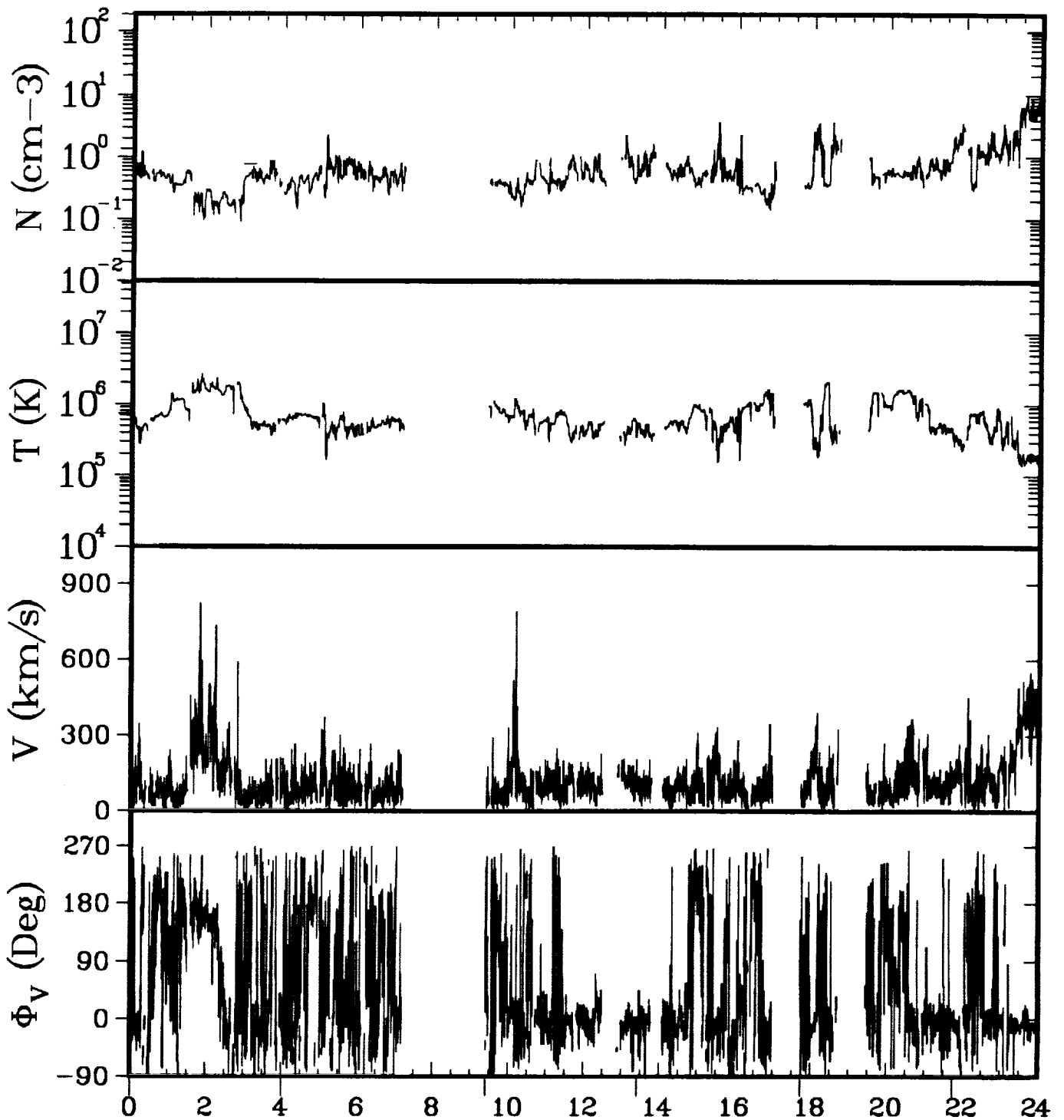

ISEE-3 ELECTRONS 03/27/83

GSEX	-95.3	-93.9	-91.8	-90.2	-88.5	-86.8
Y	-8.6	-9.5	-10.8	-11.7	-12.7	-13.6
Z	4.4	4.5	4.5	4.6	4.7	4.7
GSMY	-9.6	-10.5	-11.5	-12.4	-13.4	-13.8
Z	-1.3	-0.1	2.2	1.6	-1.5	-3.9

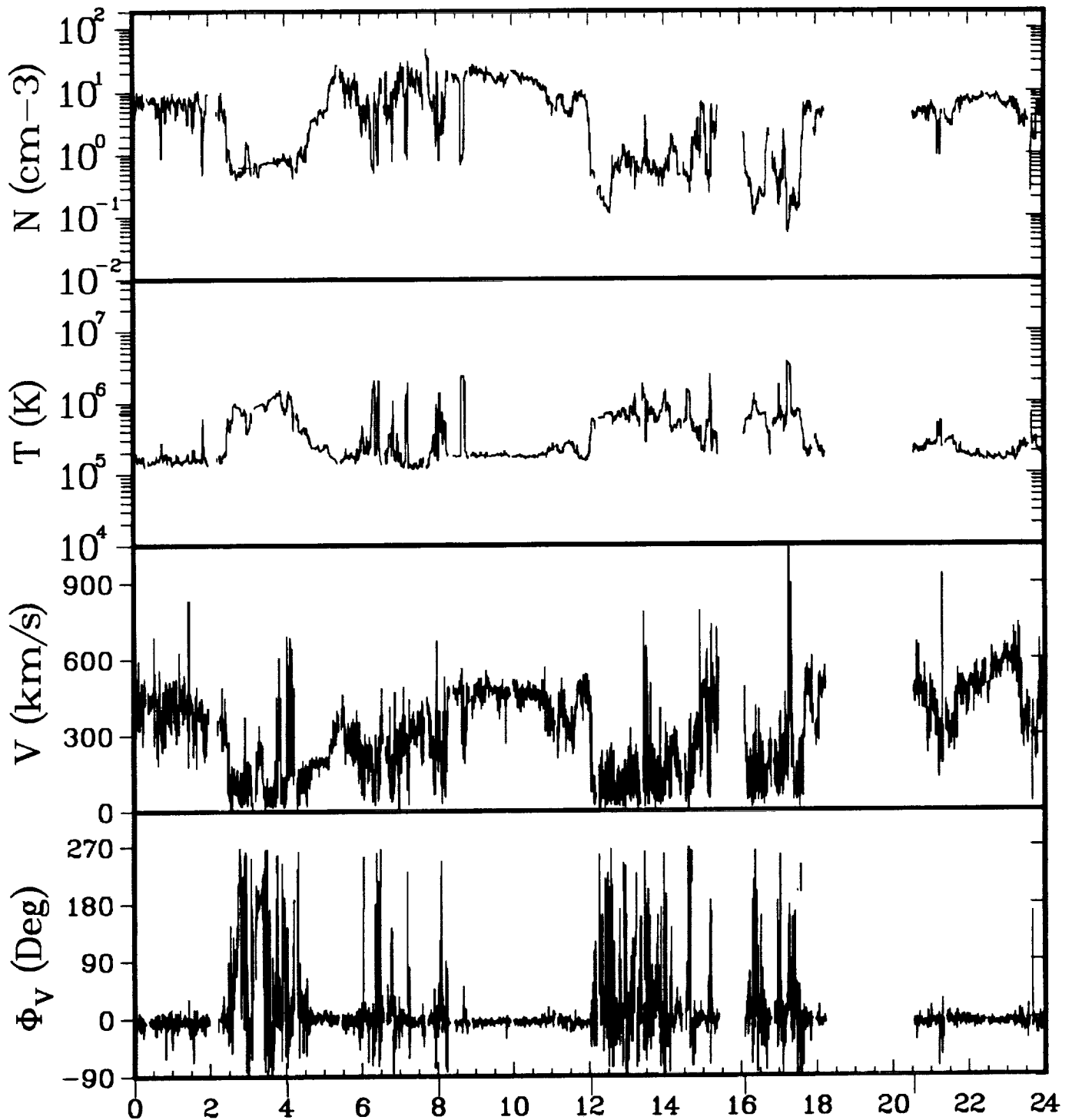

ISEE-3 ELECTRONS 03/28/83

GSEX	-85.9	-84.2	-82.5	-80.7	-78.8	-76.8
Y	-14.1	-15.0	-15.9	-16.8	-17.8	-18.8
Z	4.7	4.8	4.8	4.9	4.9	5.0
GSMY	-14.3	-15.6	-16.6	-17.5	-18.3	-18.4
Z	-4.0	-2.1	0.8	1.2	-1.9	-6.2

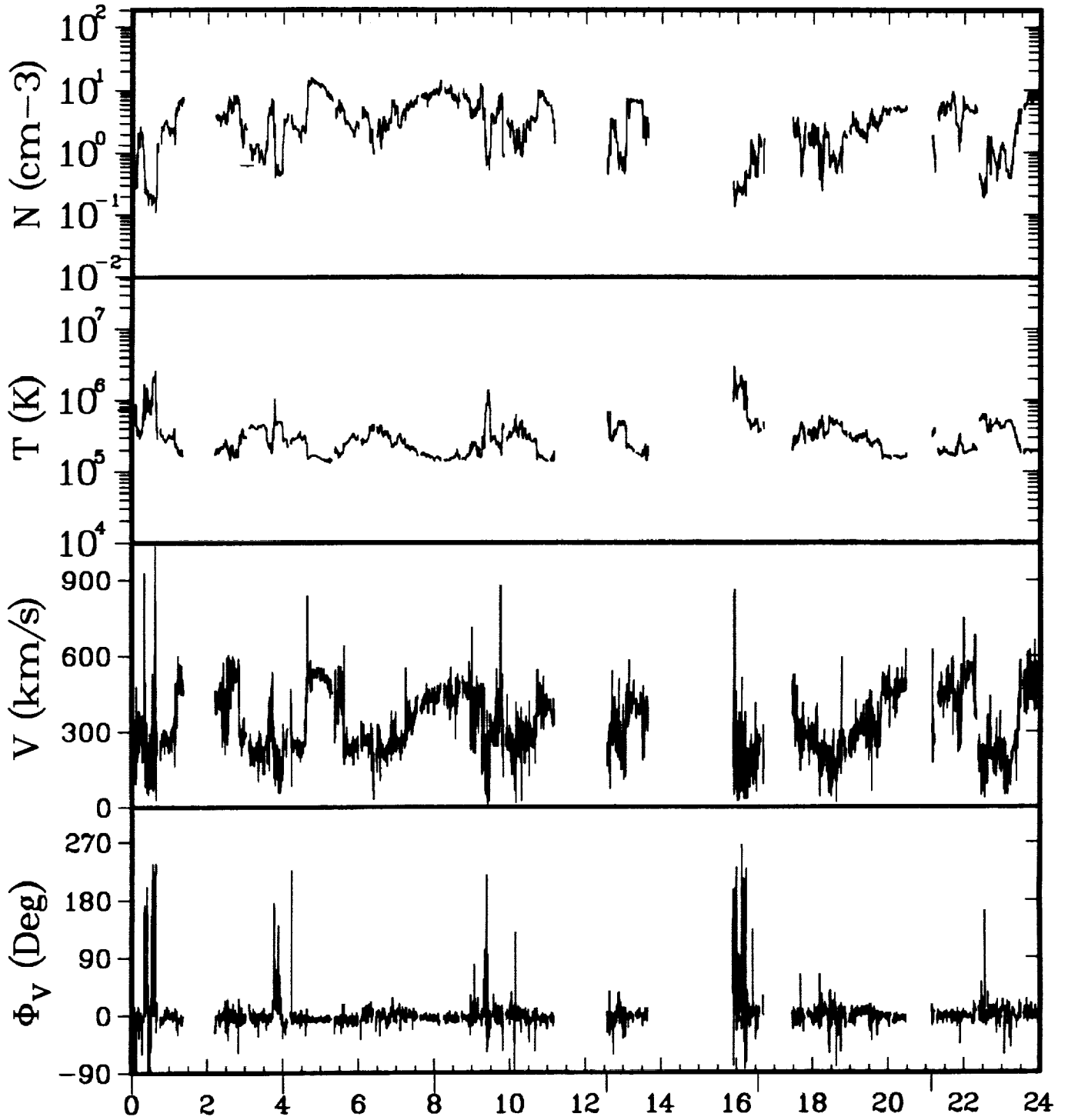

ISEE-3 ELECTRONS 03/29/83

GSEX	-75.1	-73.2	-71.1	-68.8	-66.6	-64.1
Y	-19.6	-20.5	-21.4	-22.4	-23.2	-24.2
Z	5.0	5.0	5.1	5.1	5.1	5.1
GSMY	-19.0	-20.7	-21.9	-22.9	-23.4	-22.9
Z	-6.9	-4.2	-0.4	0.0	-4.3	-9.3

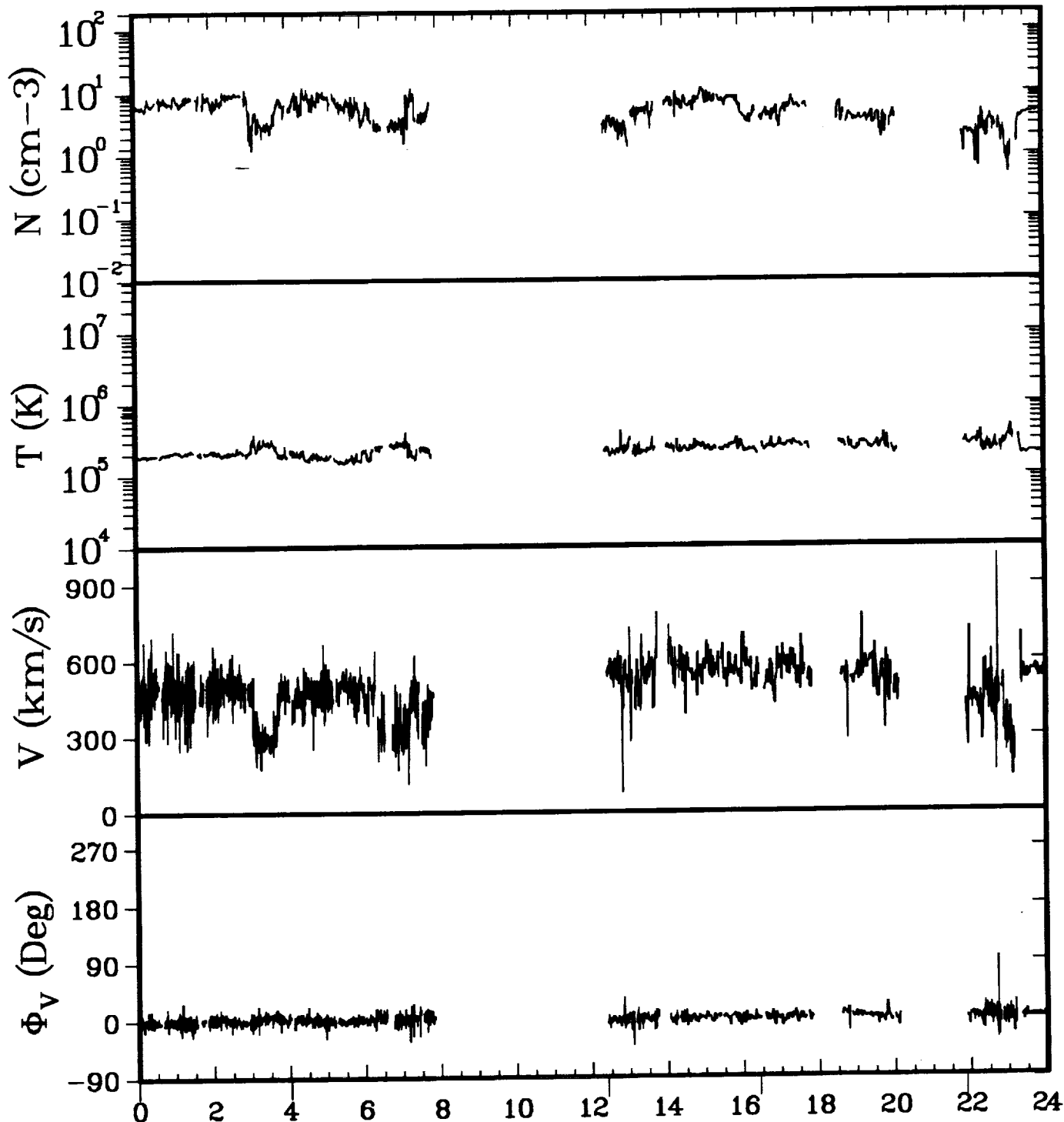

ISEE-3 ELECTRONS 03/30/83

GSEX	-62.5	-60.1	-54.9	-52.3	-48.9
Y	-24.7	-25.5	-26.9	-27.2	-27.3
Z	5.1	5.1	5.1	5.0	4.8
GSMY	-23.3	-25.3	-27.3	-27.1	-25.2
Z	-9.7	-6.2	-0.8	-5.7	-11.6

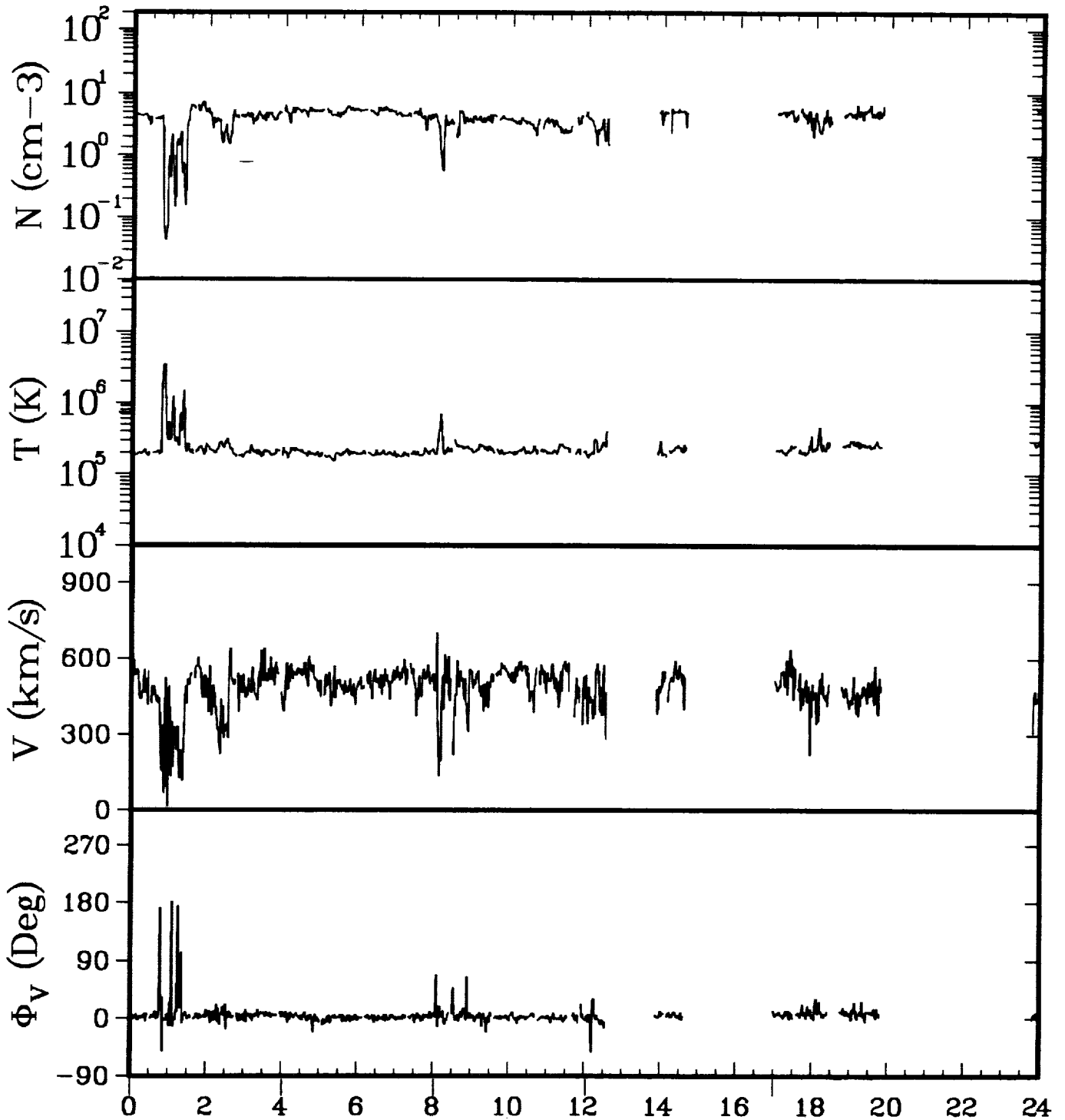

ISEE-3 ELECTRONS 03/31/83

GSEX	-47.7	-45.4	-43.1	-40.7	-37.6
Y	-27.3	-27.3	-27.2	-27.2	-27.0
Z	4.7	4.5	4.2	3.9	3.6
GSMY	-25.2	-26.6	-27.4	-27.4	-26.1
Z	-11.5	-7.6	-2.5	-1.8	-7.7

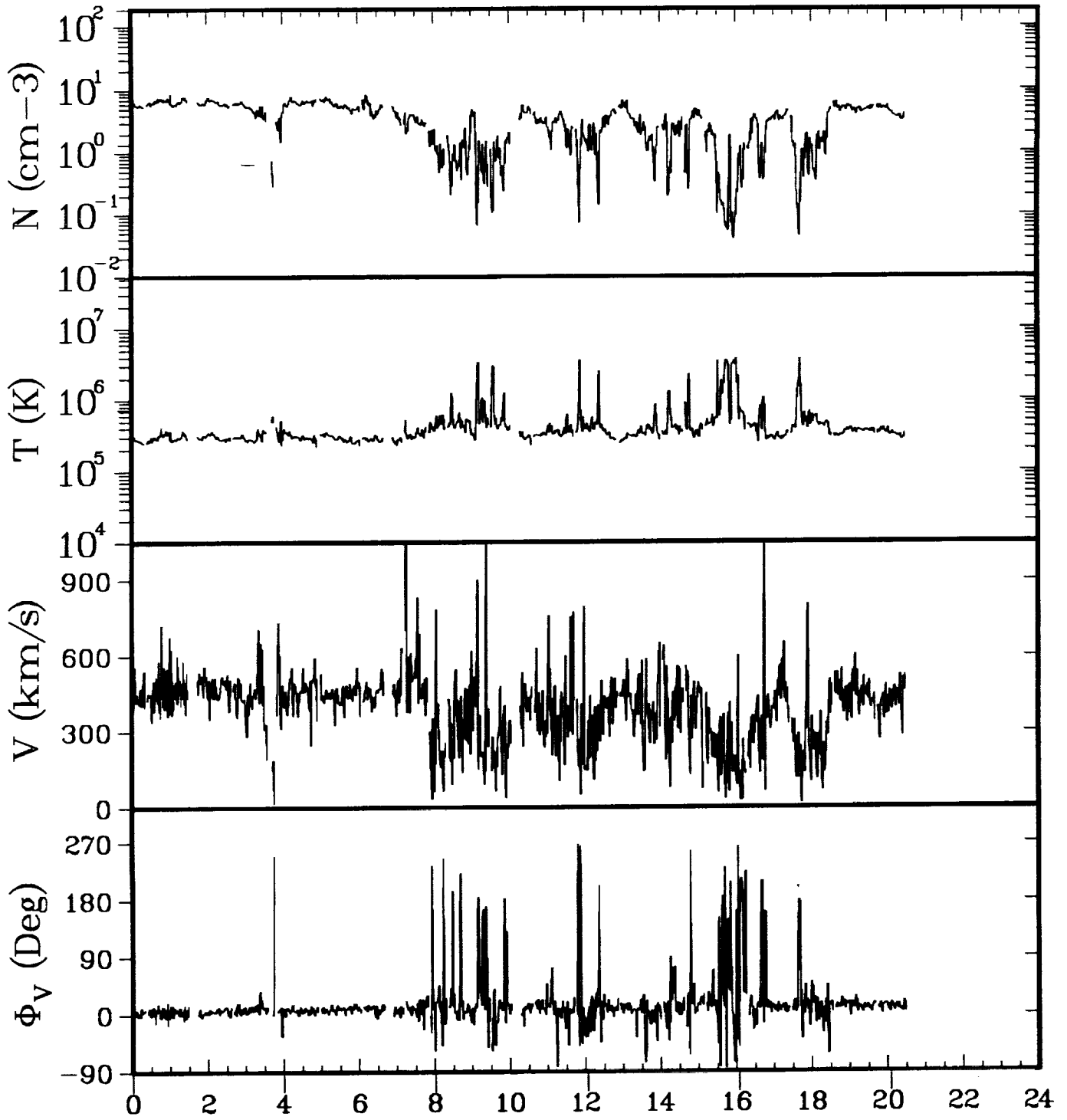

ISEE-3 ELECTRONS 04/01/83

GSEX	-33.0	-30.2	-27.3	-24.1	-20.9	-17.4
Y	-26.6	-26.3	-25.9	-25.3	-24.6	-23.6
Z	3.1	2.8	2.4	2.1	1.7	1.4
GSMY	-23.8	-25.0	-25.7	-25.2	-23.5	-20.7
Z	-12.4	-8.7	-3.9	-3.2	-7.2	-11.5

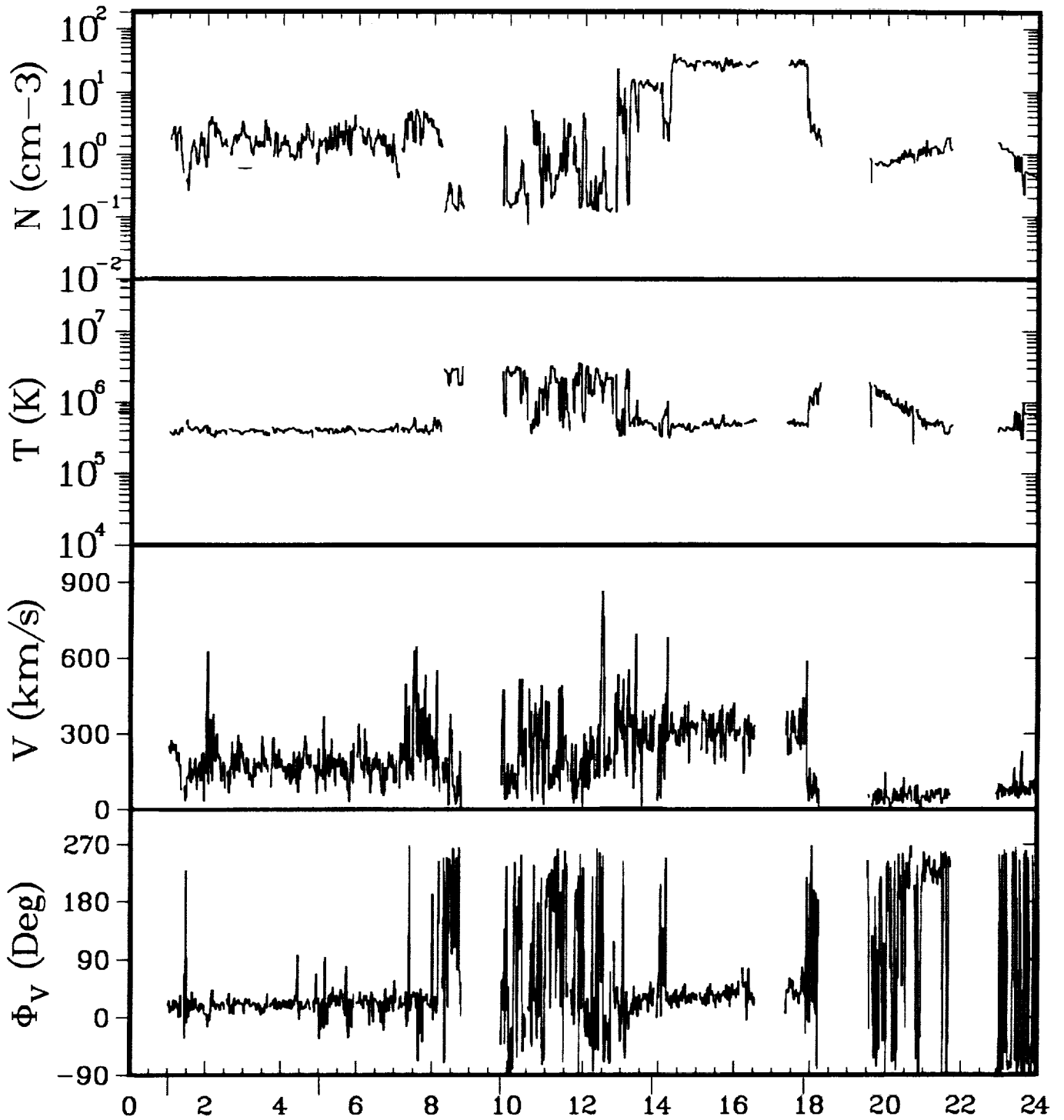

ISEE-3 ELECTRONS 04/02/83

GSEX	-12.8	-8.7	-3.6	1.0	5.4
Y	-22.1	-20.3	-17.5	-14.0	-9.0
Z	0.9	0.5	0.0	-0.5	-0.8
GSMY	-19.0	-19.0	-17.1	-13.5	-7.7
Z	-11.2	-7.2	-3.5	-4.0	-4.8

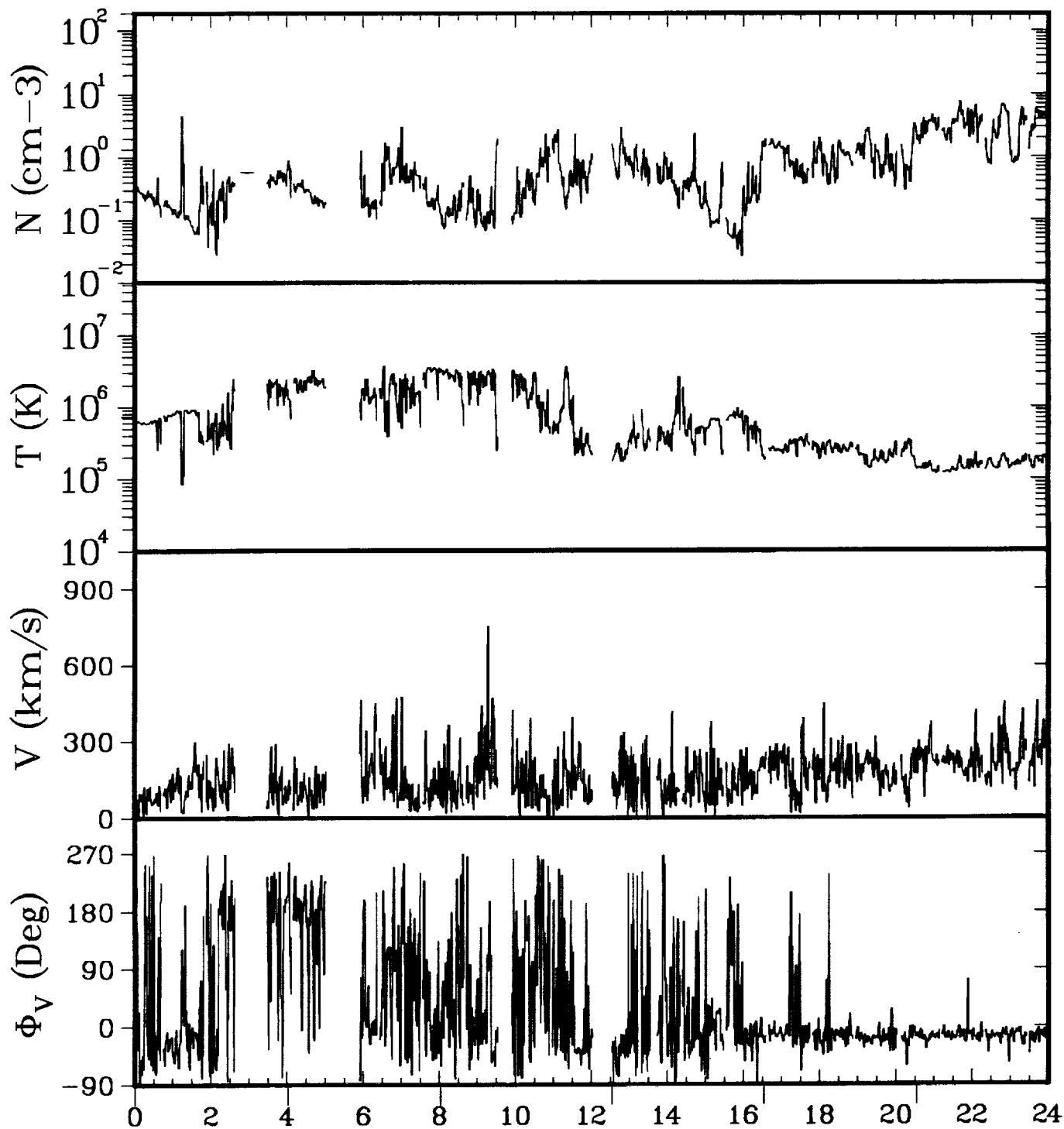

ISEE-3 ELECTRONS 04/03/83

GSEX	7.9	4.9	0.5	-4.5	-8.7	-12.7
Y	2.9	9.9	14.7	18.3	20.6	22.3
Z	-0.8	-0.3	0.3	1.0	1.5	2.0
GSMY	2.8	9.1	14.2	17.7	18.5	17.6
Z	0.9	3.9	3.8	4.9	9.3	13.9

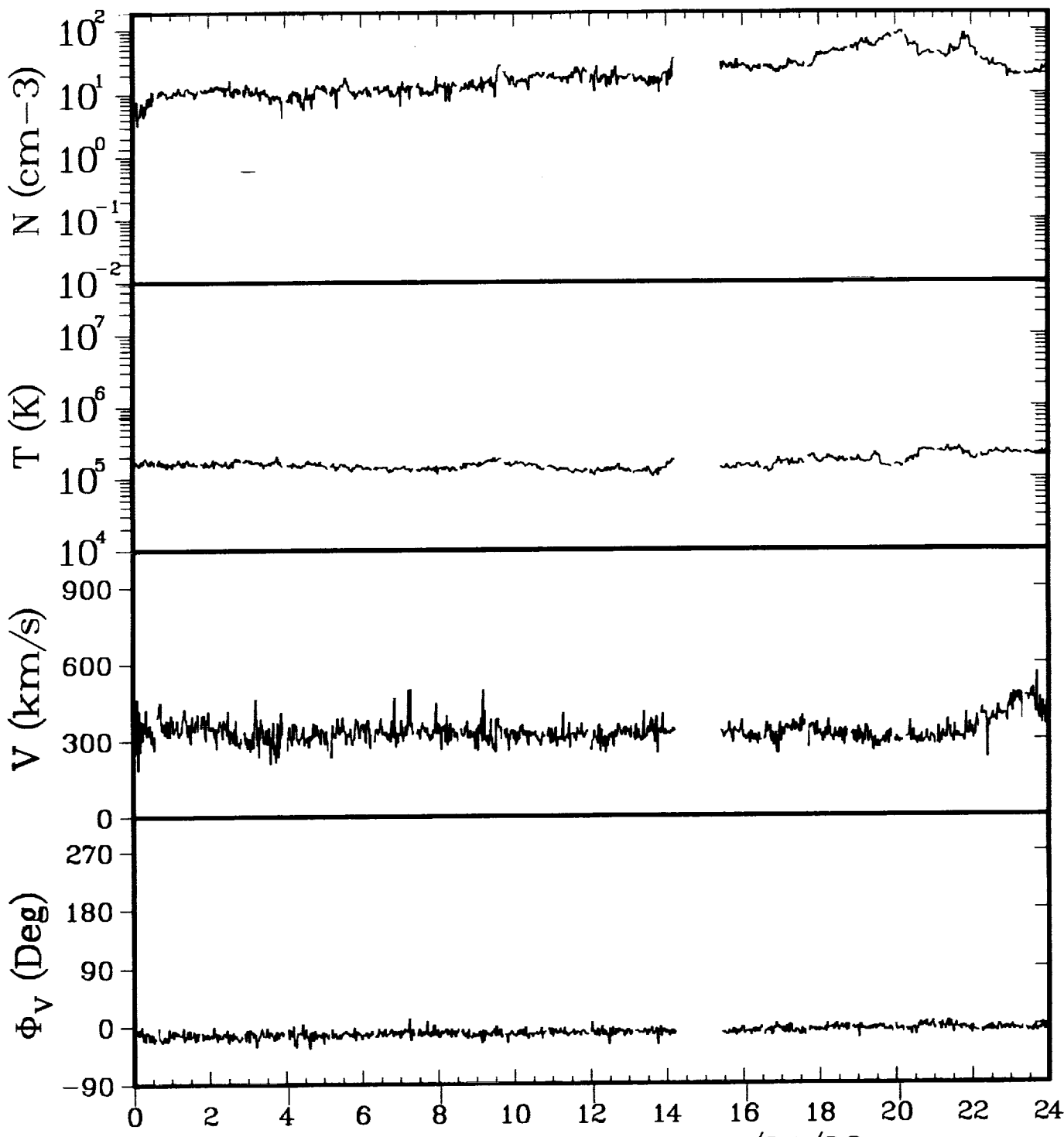

ISEE-3 ELECTRONS 04/04/83

GSEX	-15.9	-19.5	-22.8	-25.9	-28.9	-31.7
Y	23.5	24.6	25.4	26.0	26.5	26.9
Z	2.4	2.8	3.2	3.6	3.9	4.3
GSMY	18.2	21.1	23.9	24.8	23.3	20.5
Z	15.1	12.8	9.1	8.8	13.2	17.9

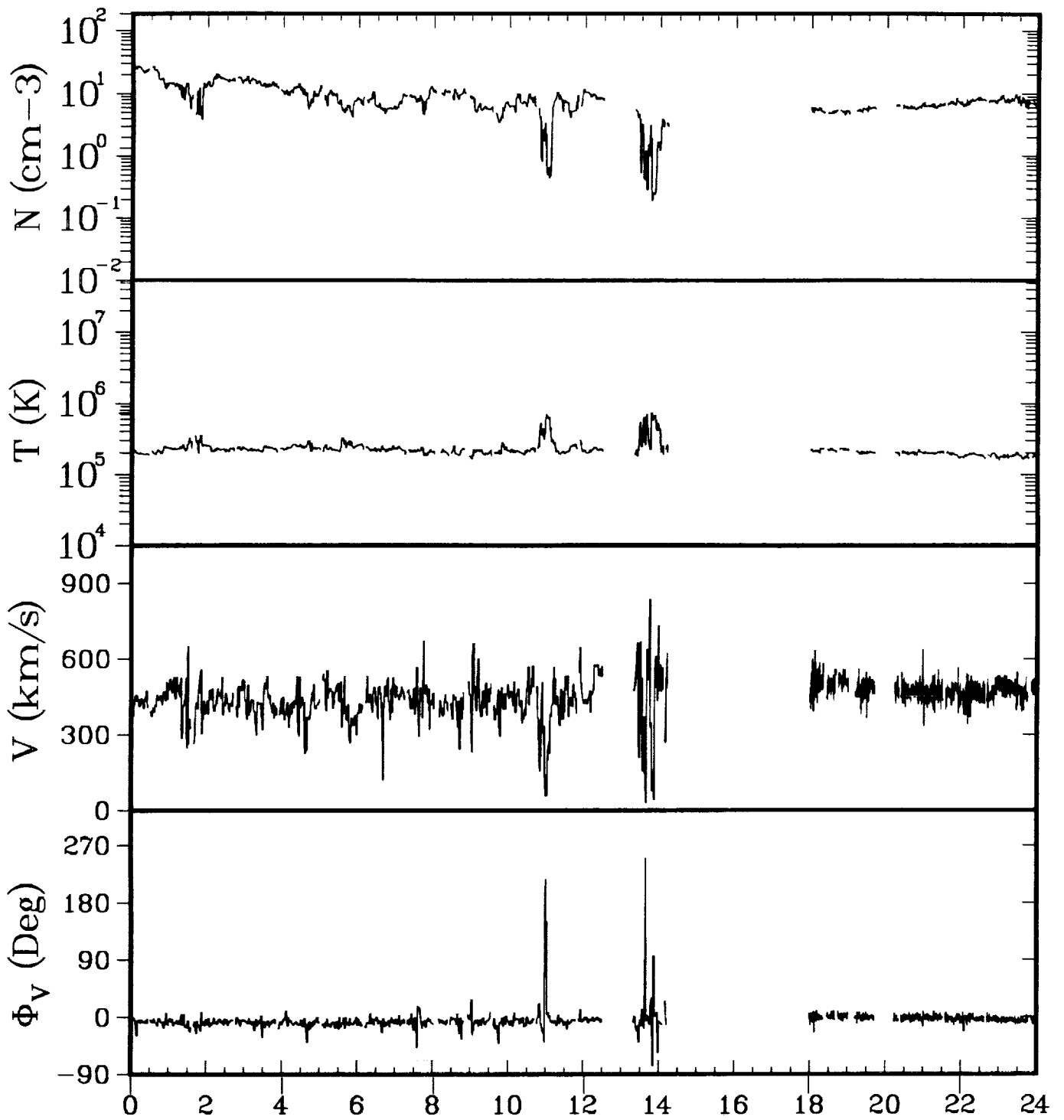

ISEE-3 ELECTRONS 04/05/83

GSEX	-34.3	-36.9	-39.3	-41.6	-44.9	-46.9
Y	27.1	27.3	27.4	27.5	27.4	27.3
Z	4.6	4.8	5.1	5.4	5.7	6.0
GSMY	20.0	22.8	25.5	25.8	21.9	19.2
Z	18.9	15.8	11.4	10.8	17.5	20.4

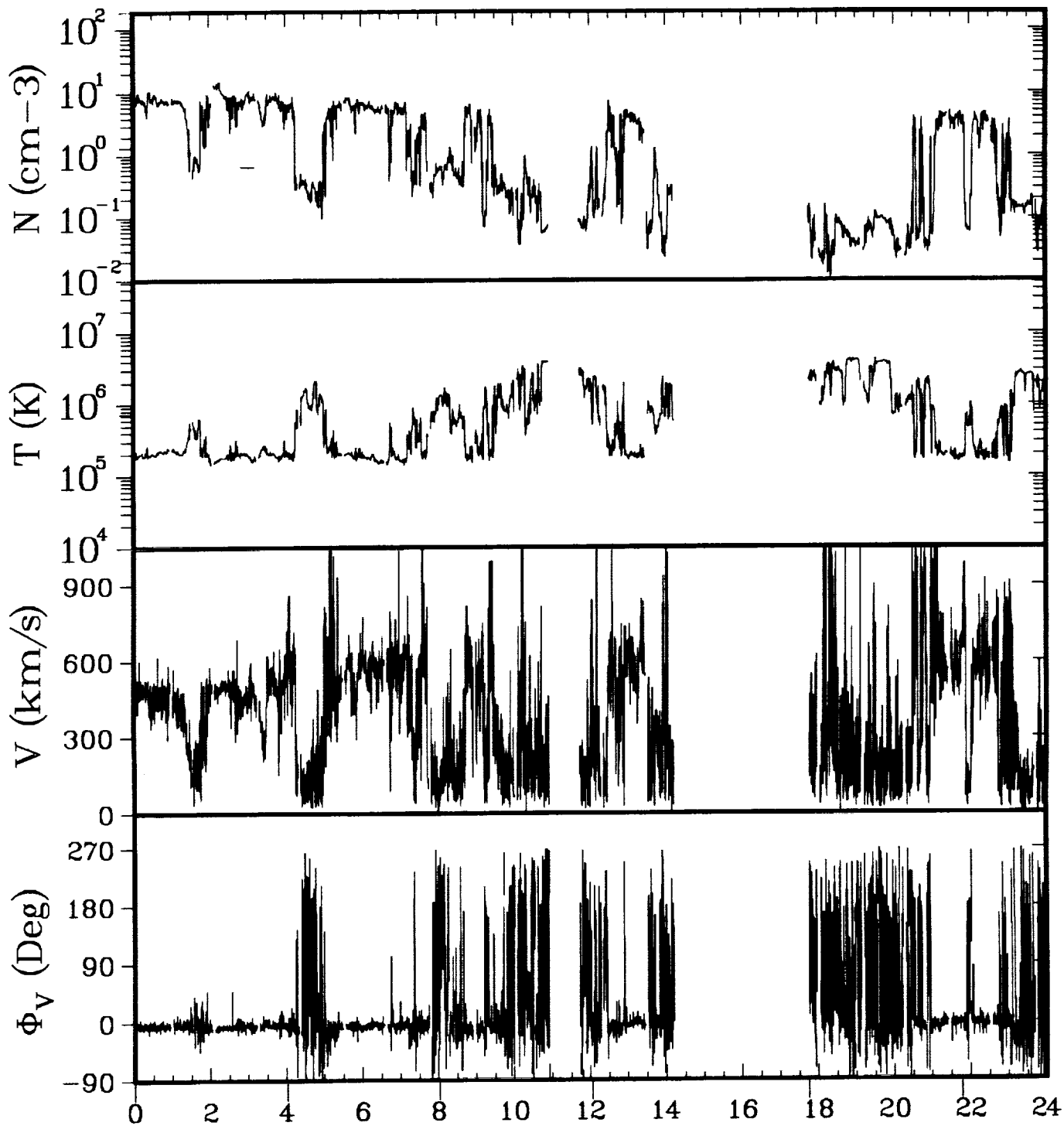

ISEE-3 ELECTRONS 04/06/83

GSEX	-48.0	-49.9	-51.7	-53.5	-55.9	-57.5
Y	27.3	27.1	27.0	26.7	26.4	26.1
Z	6.1	6.3	6.5	6.7	6.9	7.1
GSMY	19.3	22.1	24.7	24.9	20.6	17.6
Z	20.2	17.0	12.6	11.8	17.8	20.5

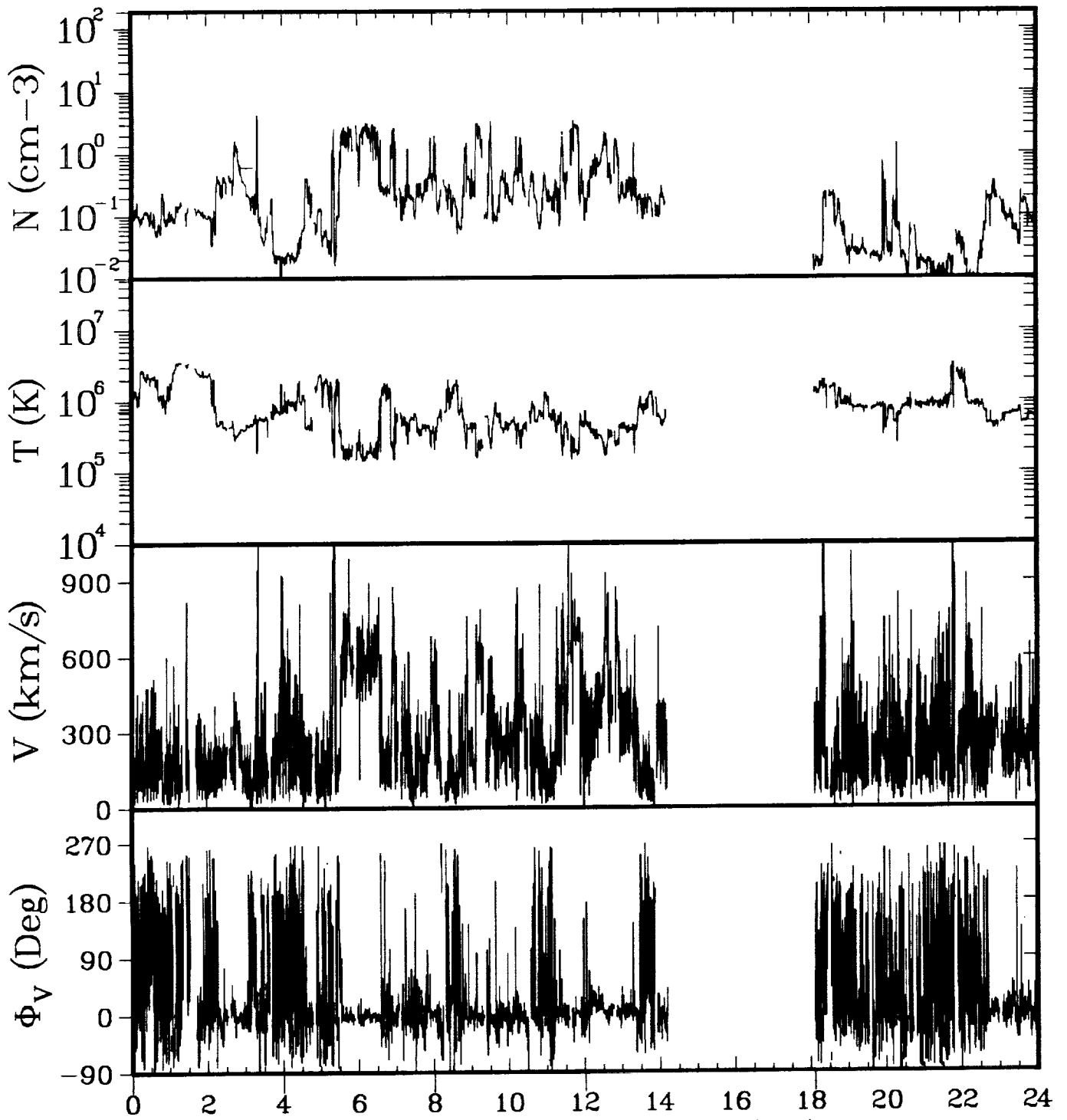

ISEE-3 ELECTRONS 04/07/83

GSEX	-58.3	-59.8	-61.2	-62.6	-64.5
Y	26.0	25.6	25.3	25.0	24.4
Z	7.2	7.3	7.5	7.6	7.8
GSMY	17.6	20.3	22.9	23.0	18.2
Z	20.3	17.3	13.1	12.3	18.0

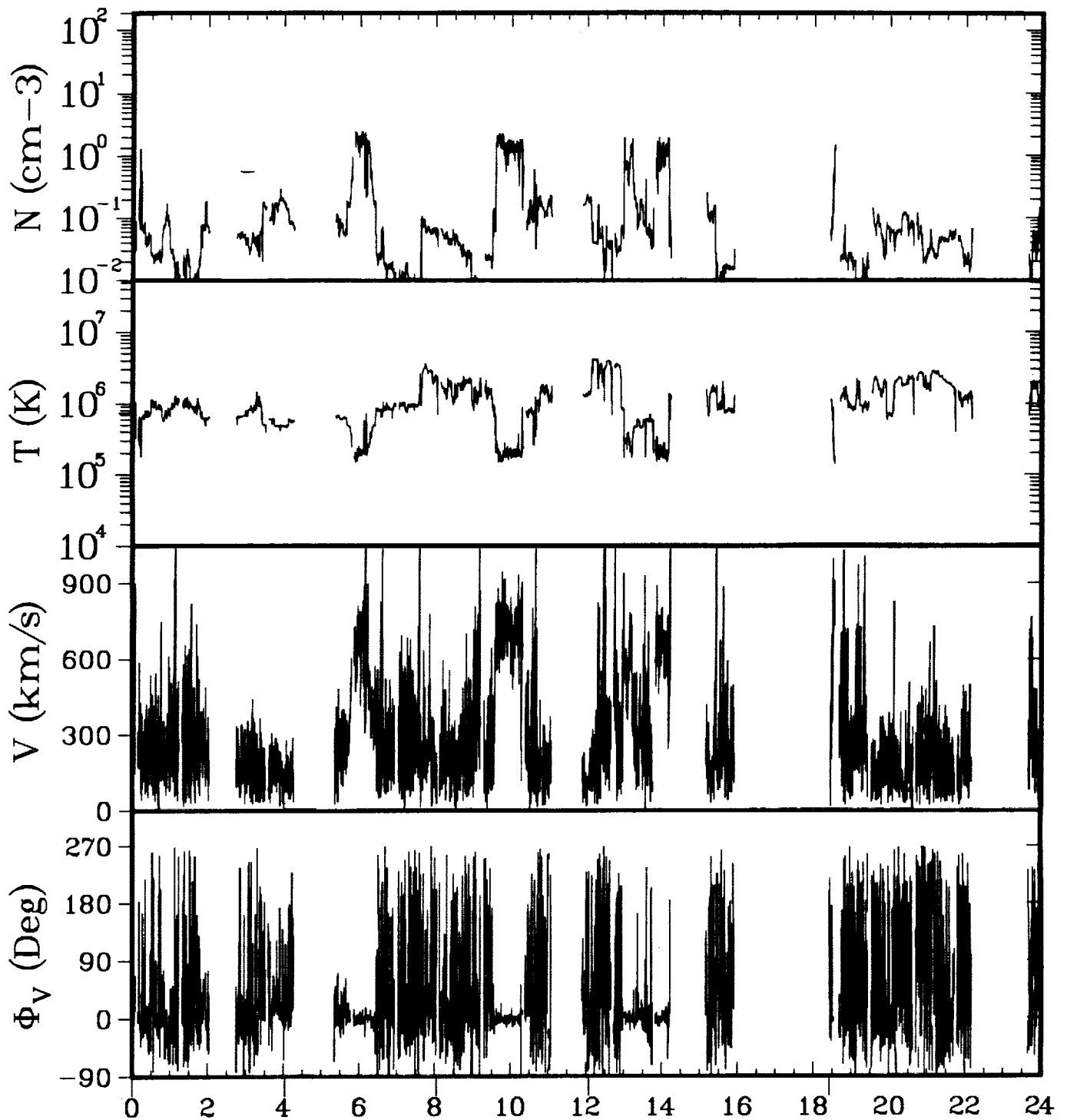

ISEE-3 ELECTRONS 04/08/83

GSEX	-66.3	-67.4	-68.5	-69.5	-71.0
Y	23.8	23.4	23.0	22.5	21.8
Z	7.9	8.0	8.1	8.2	8.4
GSMY	15.5	18.0	20.5	20.5	15.3
Z	19.8	16.9	13.2	12.5	17.6

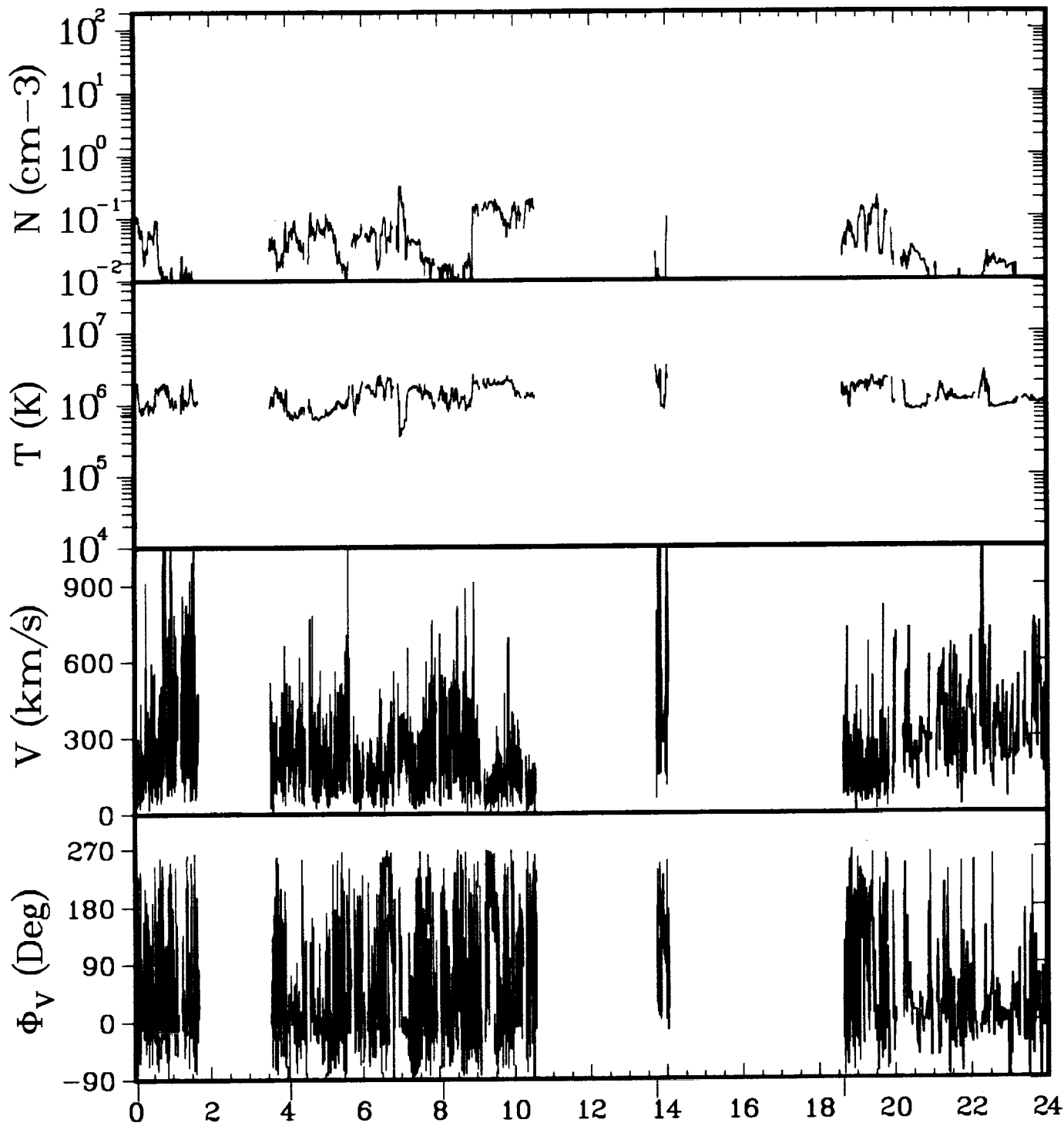

ISEE-3 ELECTRONS 04/09/83

GSEX	-72.3	-73.1	-73.9	-74.9	-75.7
Y	21.1	20.6	20.1	19.4	18.8
Z	8.5	8.5	8.6	8.7	8.7
GSMY	13.0	15.4	17.7	16.8	12.4
Z	18.7	16.2	12.9	13.0	16.6

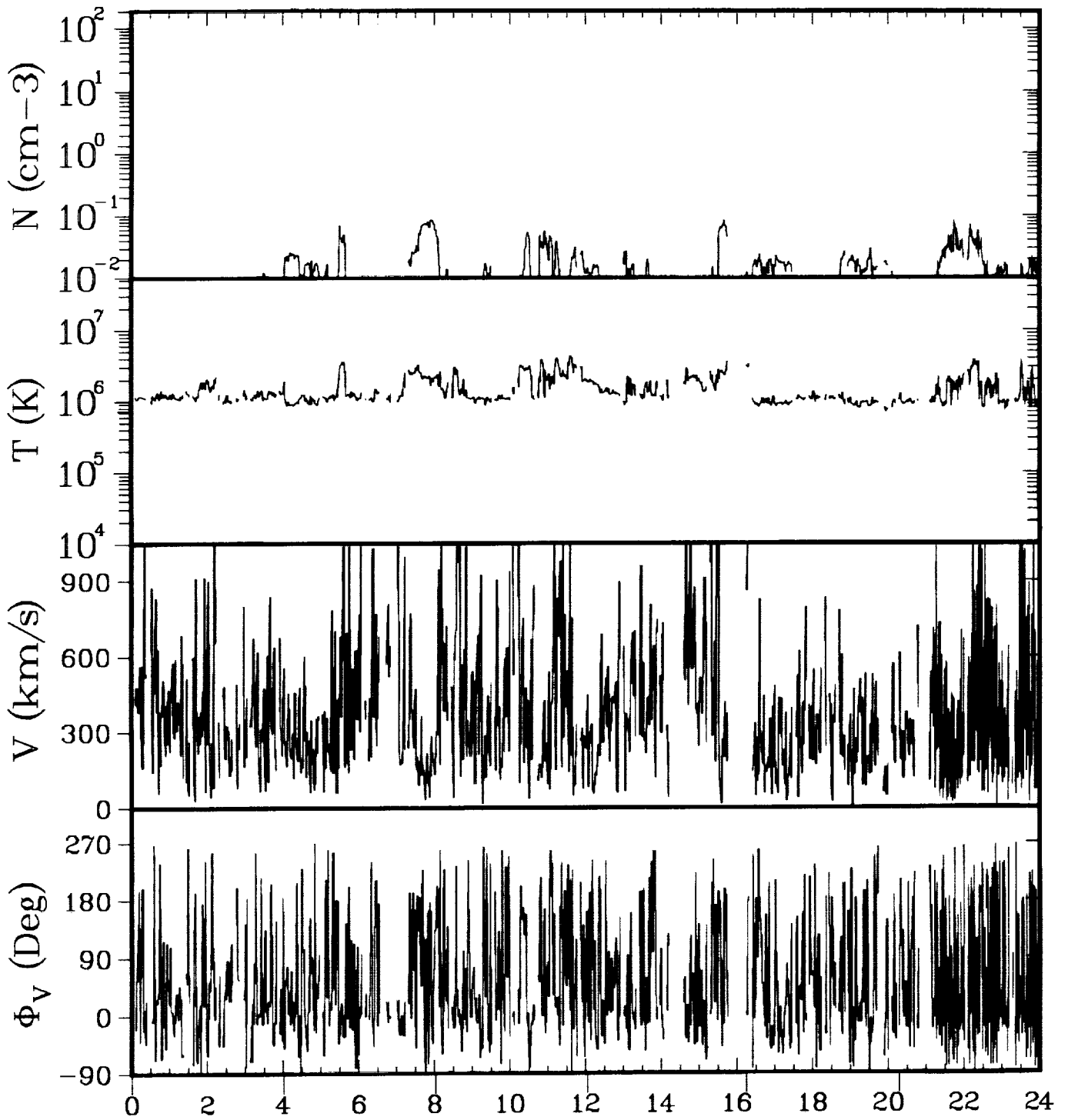

ISEE-3 ELECTRONS 04/10/83

GSEX	-76.5	-77.0	-77.5	-78.0	-78.4	-78.8
Y	18.1	17.6	17.0	16.5	15.9	15.3
Z	8.8	8.8	8.8	8.8	8.8	8.8
GSMY	10.3	12.4	14.6	14.5	11.7	8.3
Z	17.2	15.2	12.4	11.8	13.9	15.6

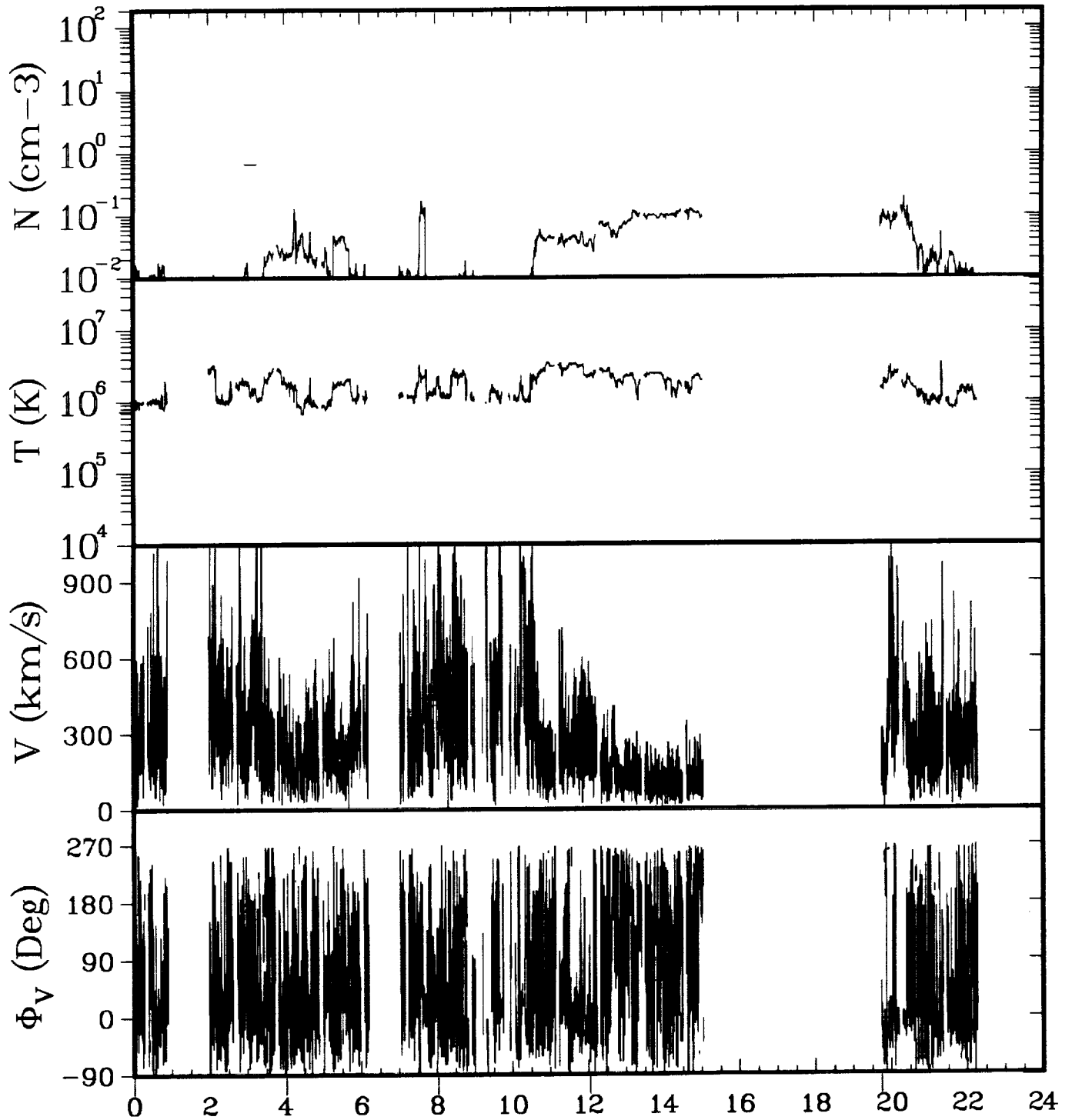

ISEE-3 ELECTRONS 04/11/83

GSEX	-79.1	-79.4	-79.6	-79.8	-80.1
Y	14.8	14.2	13.6	13.0	11.8
Z	8.8	8.8	8.8	8.8	8.8
GSMY	7.5	9.4	11.3	11.1	5.7
Z	15.5	13.8	11.6	11.1	13.6

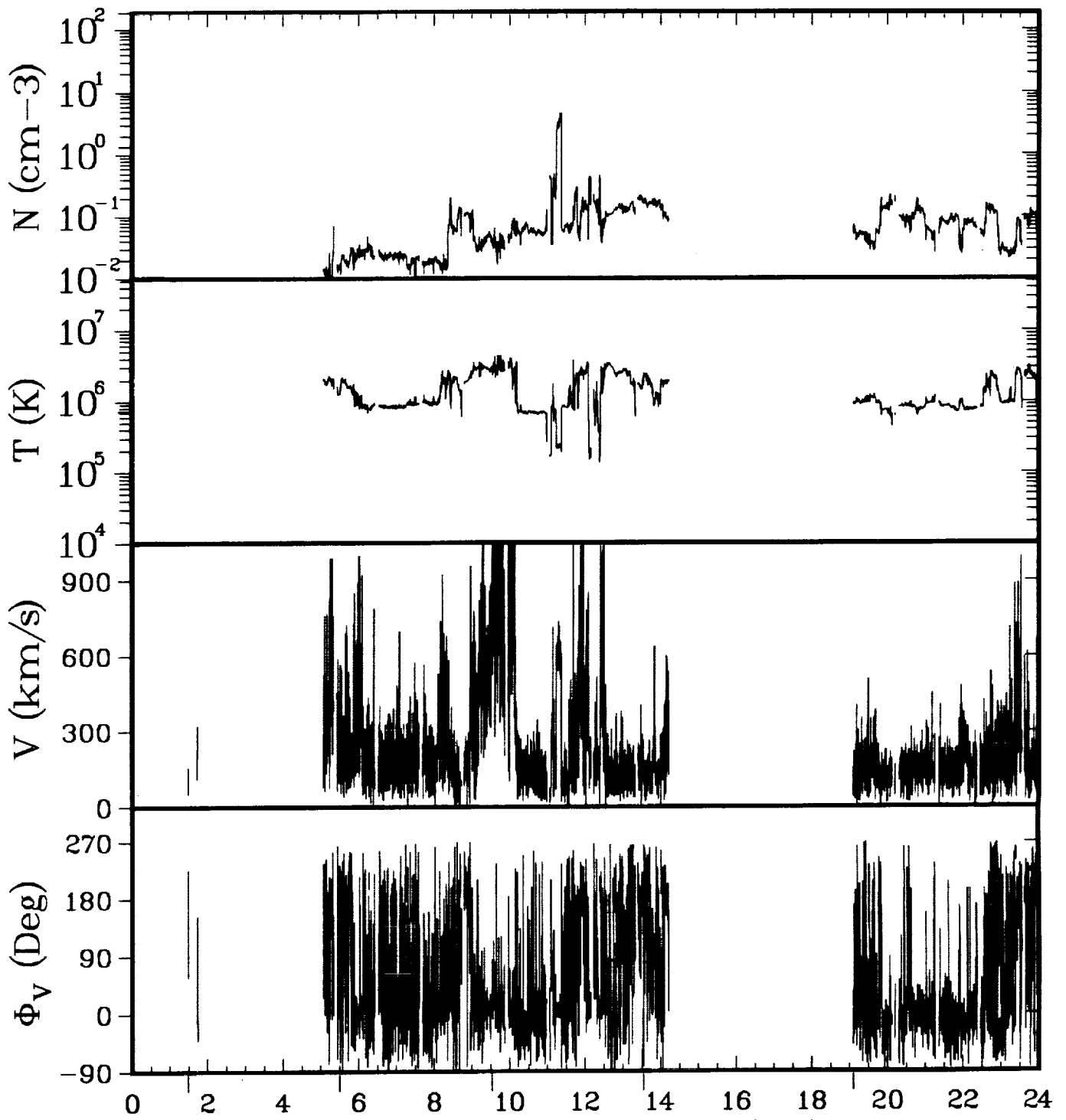

ISEE-3 ELECTRONS 04/12/83

GSEX	-80.2	-80.2	-80.2	-80.2	-80.0
Y	11.0	10.3	9.7	9.1	8.2
Z	8.7	8.7	8.6	8.6	8.5
GSMY	5.0	6.9	8.0	6.9	3.0
Z	13.1	11.6	10.3	10.4	11.4

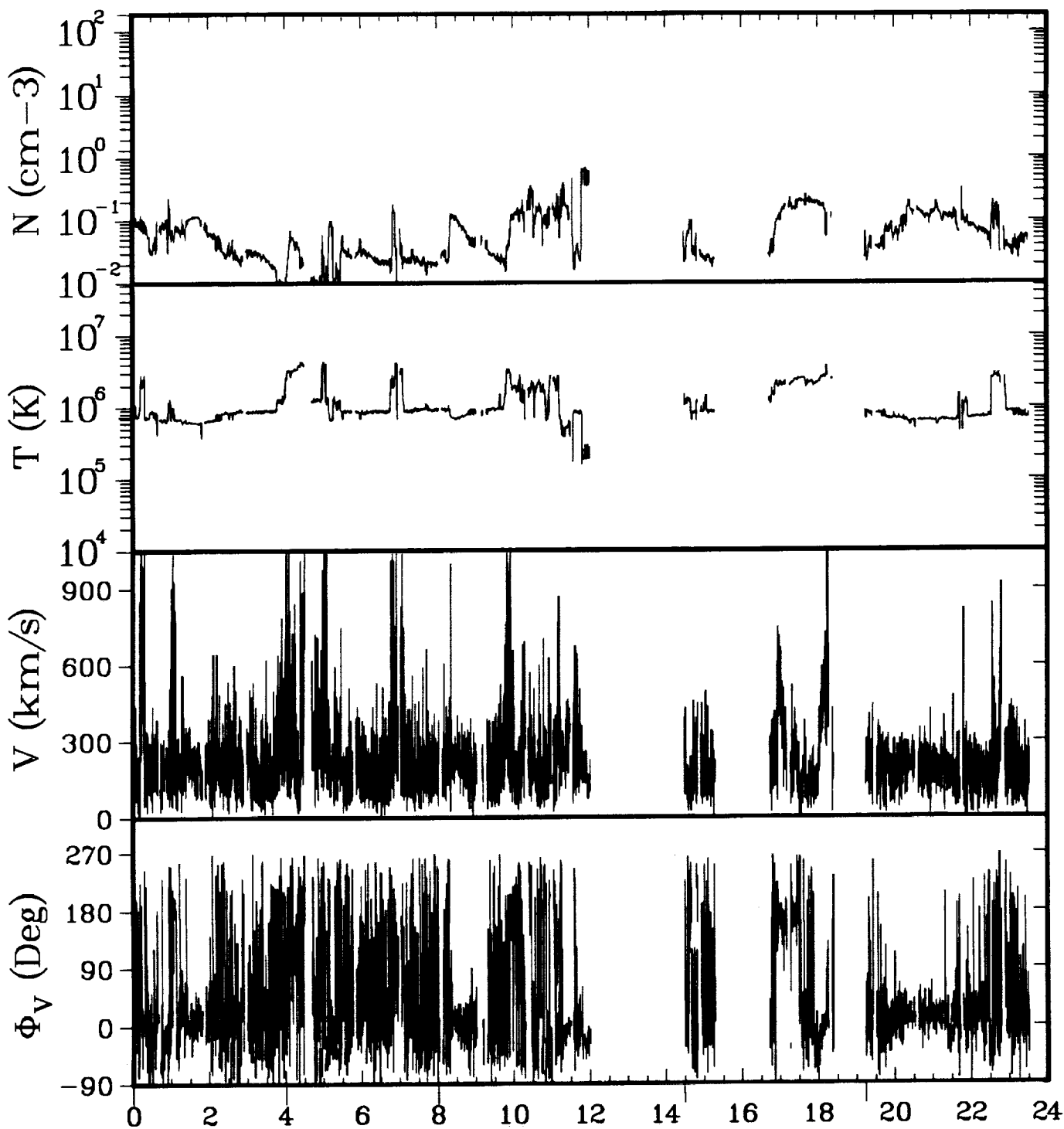

ISEE-3 ELECTRONS 04/13/83

GSEX	-79.8	-79.6	-79.4	-78.9	-78.4
Y	7.4	6.7	6.1	5.0	4.2
Z	8.5	8.4	8.3	8.2	8.1
GSMY	1.6	2.8	4.1	2.7	-0.3
Z	11.1	10.4	9.4	9.2	9.1

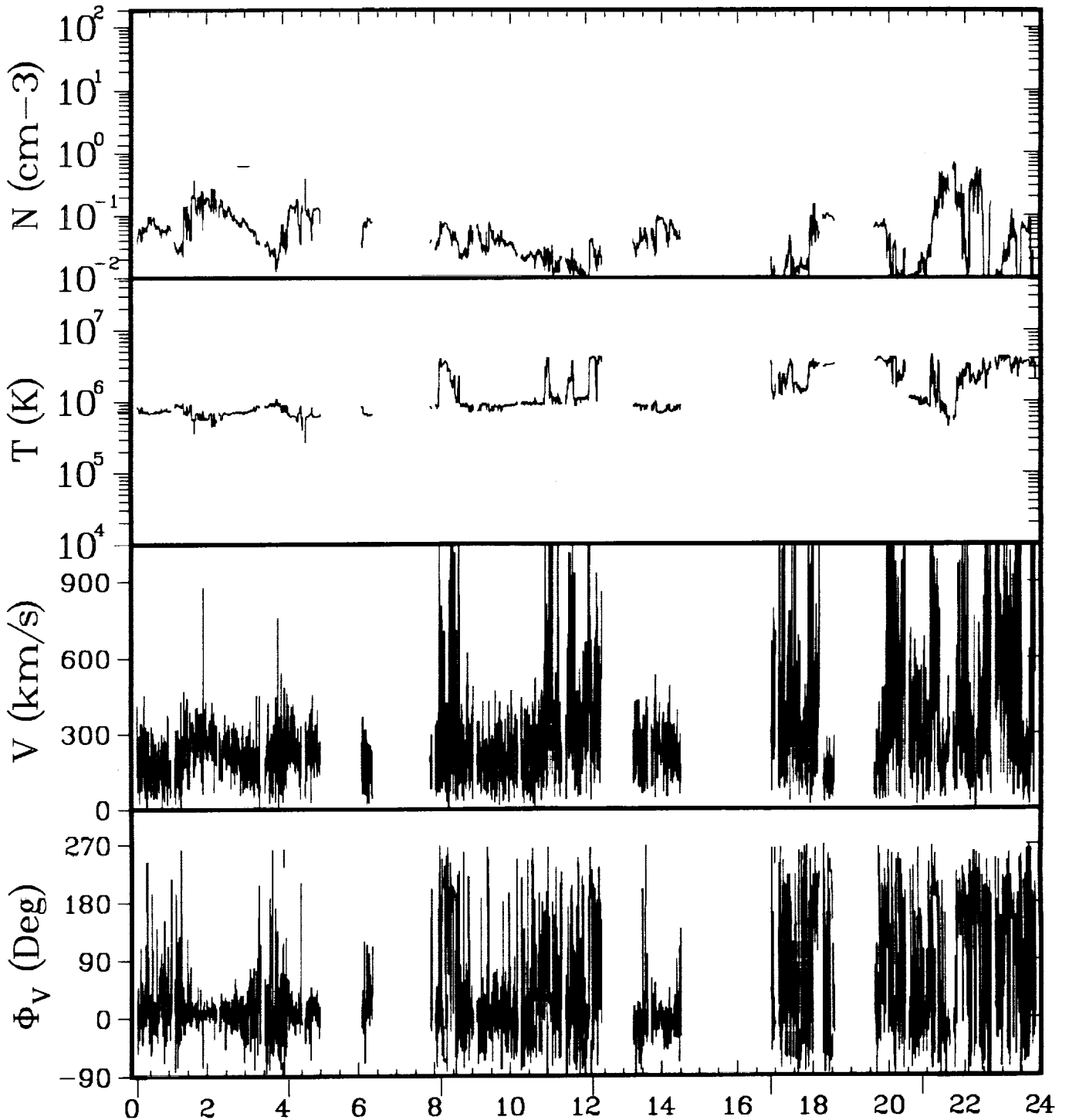

ISEE-3 ELECTRONS 04/14/83

GSEX	-77.9	-77.4	-76.9	-76.3	-75.6	-74.9
Y	3.4	2.7	2.0	1.3	0.5	-0.2
Z	8.0	7.9	7.8	7.7	7.5	7.4
GSMY	-1.4	-0.6	0.3	-0.1	-2.4	-4.2
Z	8.5	8.3	8.0	7.8	7.1	6.1

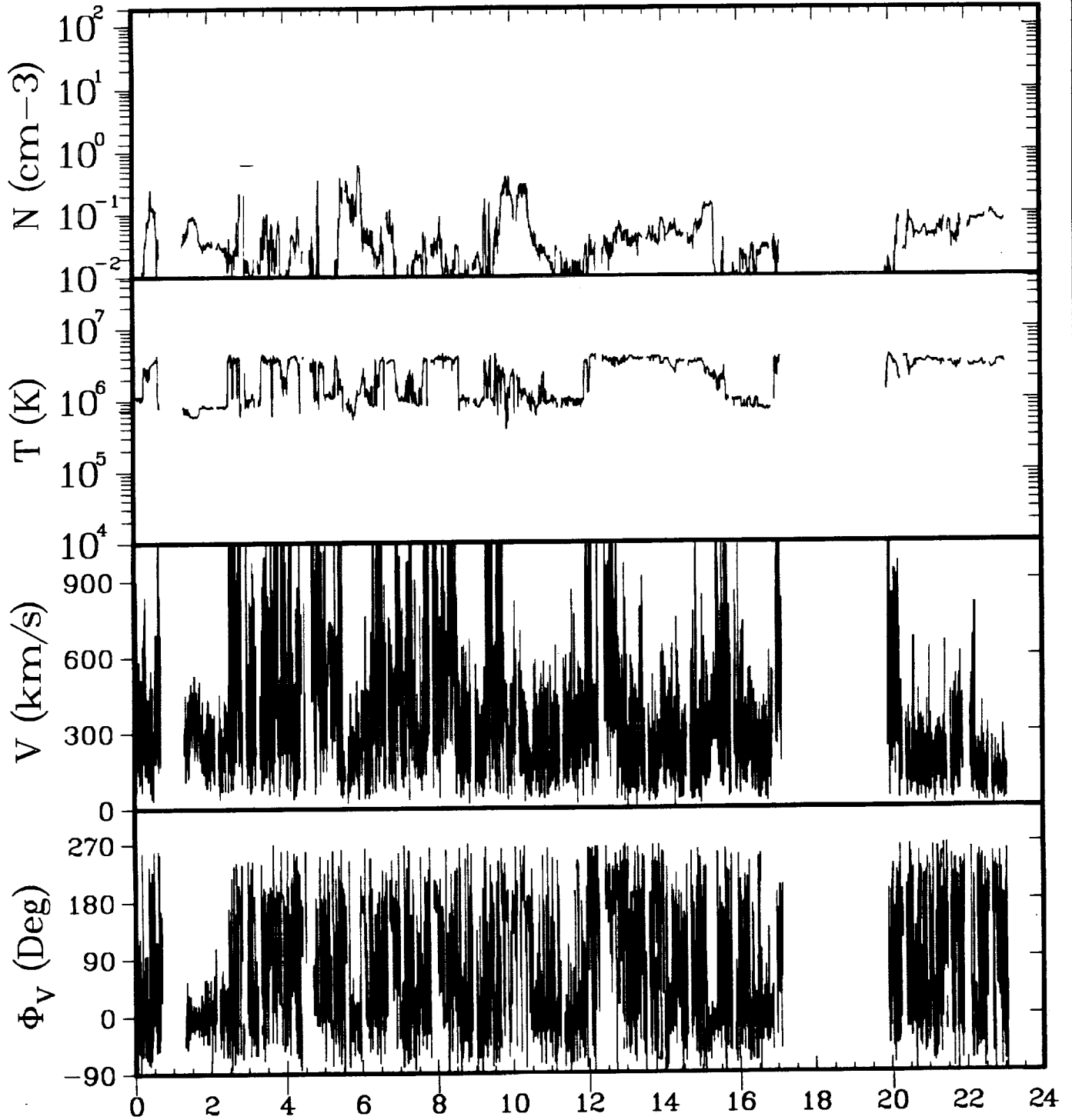

ISEE-3 ELECTRONS 04/15/83

GSEX	-74.4	-73.6	-72.8	-72.0	-71.0	-70.1
Y	-0.8	-1.5	-2.2	-2.9	-3.6	-4.3
Z	7.3	7.2	7.0	6.9	6.8	6.6
GSMY	-4.6	-4.2	-3.6	-4.1	-5.7	-7.1
Z	5.8	6.0	6.4	6.3	5.2	3.4

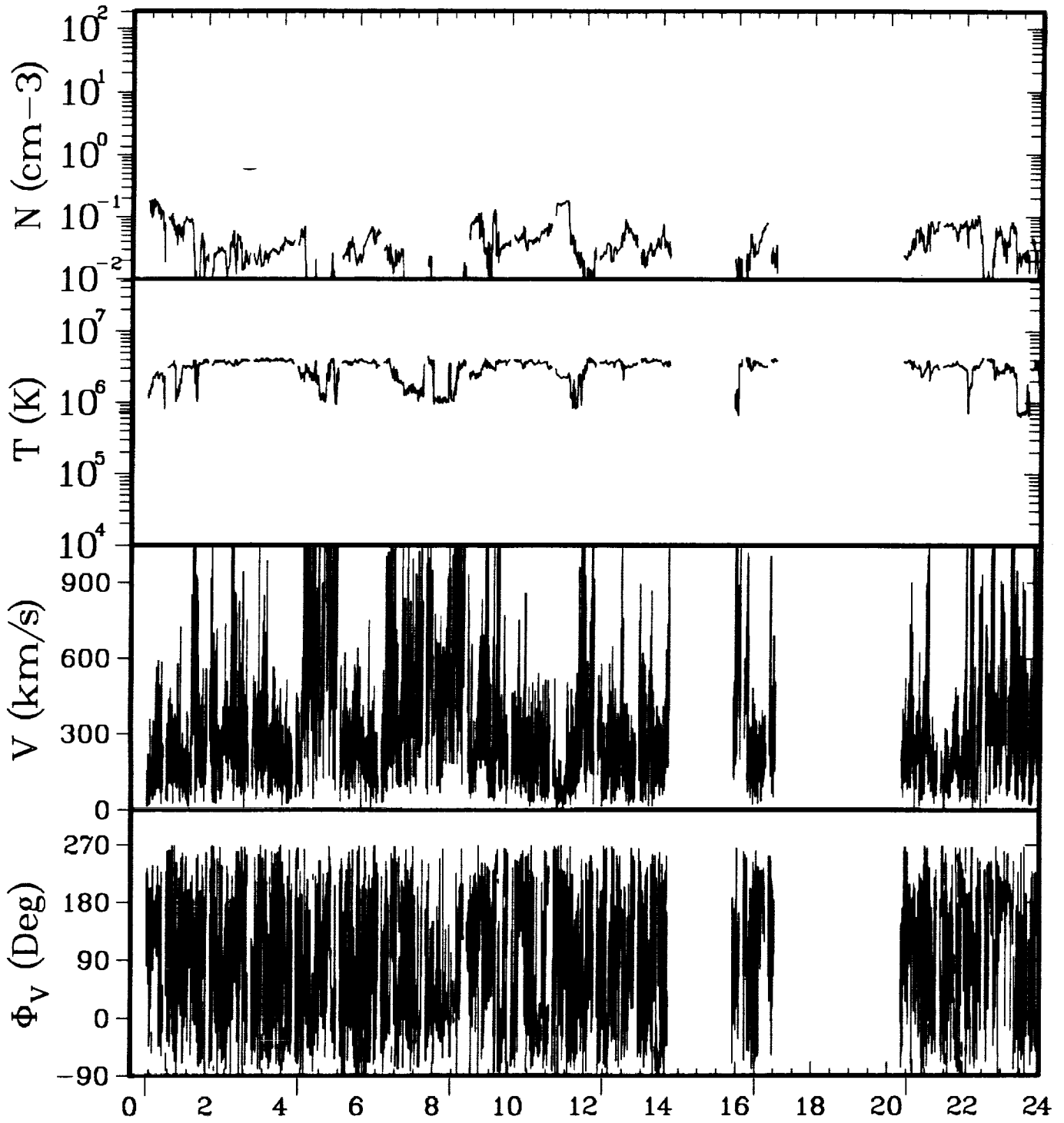

ISEE-3 ELECTRONS 04/16/83

GSEX	-68.9	-67.8	-66.7	-65.4	-64.1	-62.8
Y	-5.1	-5.9	-6.6	-7.3	-8.1	-8.8
Z	6.4	6.3	6.1	5.9	5.7	5.5
GSMY	-7.8	-7.8	-7.7	-8.3	-9.6	-10.4
Z	2.7	3.6	4.7	4.5	2.5	0.1

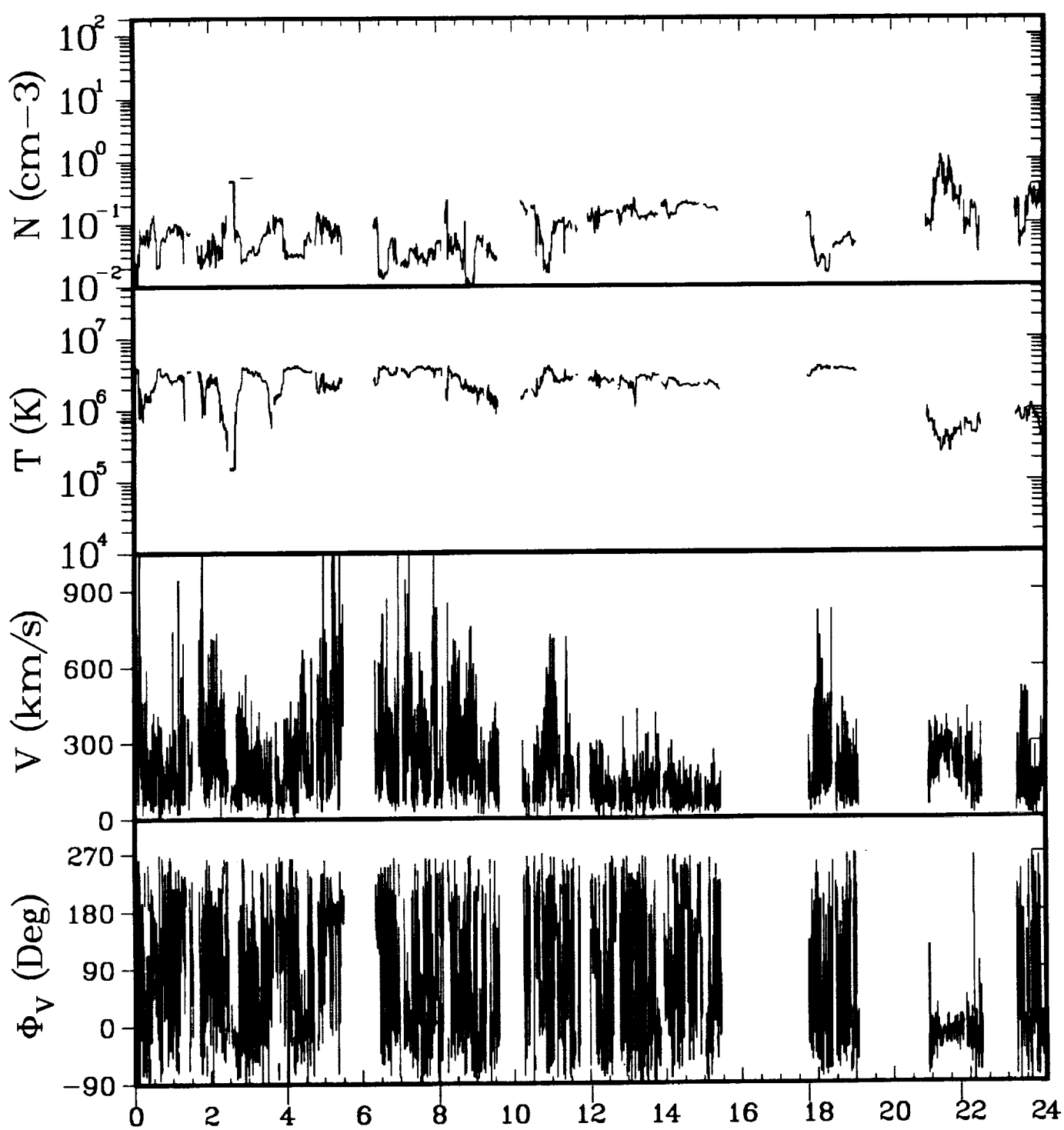

ISEE-3 ELECTRONS 04/17/83

GSEX	-61.5	-60.0	-58.5	-56.8	-54.3	-52.4
Y	-9.4	-10.1	-10.9	-11.6	-12.6	-13.3
Z	5.3	5.1	4.9	4.7	4.4	4.1
GSMY	-10.8	-11.4	-11.7	-12.2	-13.3	-13.4
Z	-0.5	0.8	2.6	2.7	-1.3	-3.7

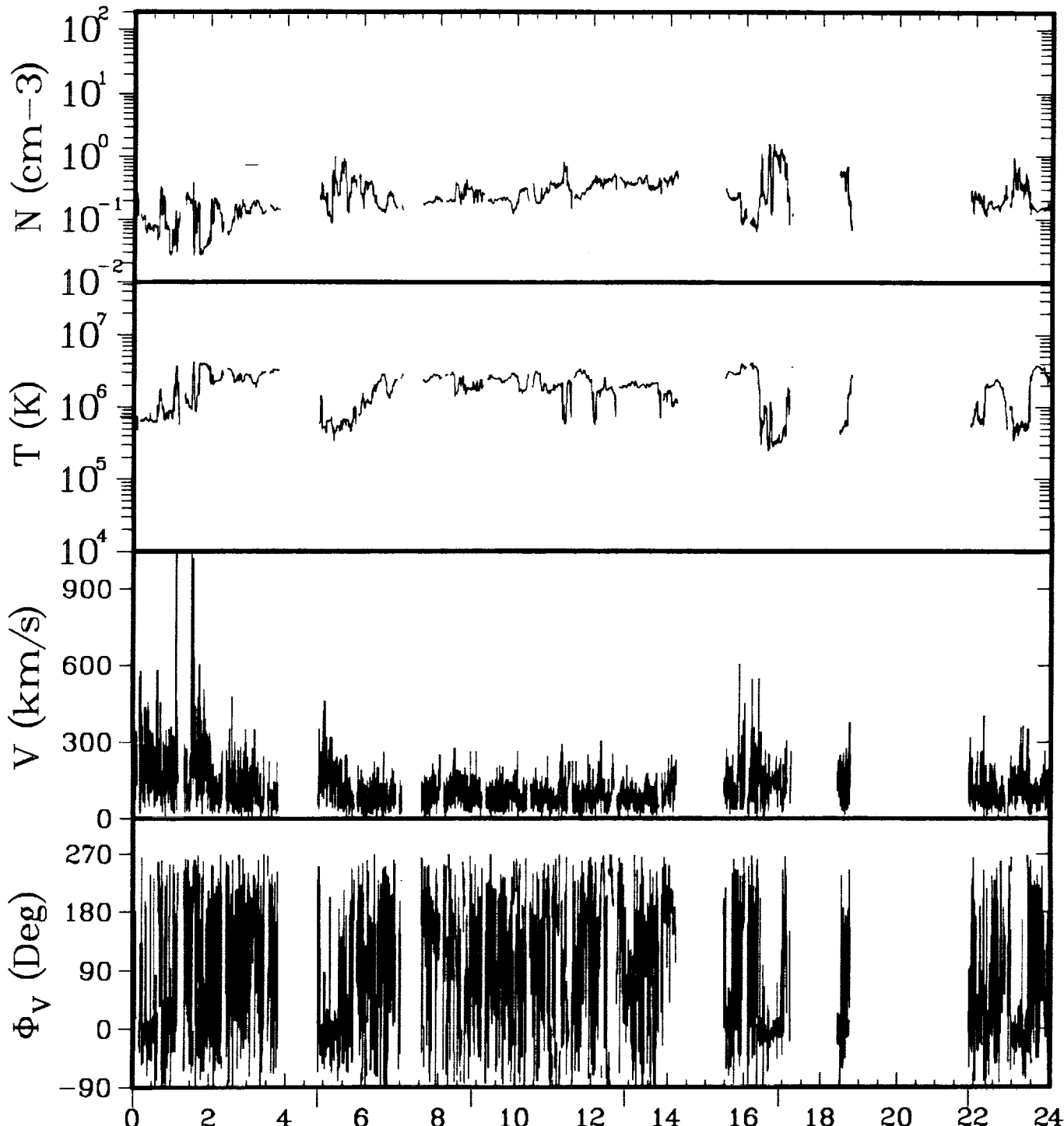

ISEE-3 ELECTRONS 04/18/83

GSEX	-51.3	-48.8	-46.7	-44.4	-41.9	-38.7
Y	-13.6	-14.4	-15.1	-15.7	-16.3	-16.9
Z	4.0	3.7	3.4	3.2	2.9	2.5
GSMY	-13.7	-14.8	-15.5	-16.0	-16.2	-15.6
Z	-3.9	-1.5	0.7	0.2	-3.4	-7.1

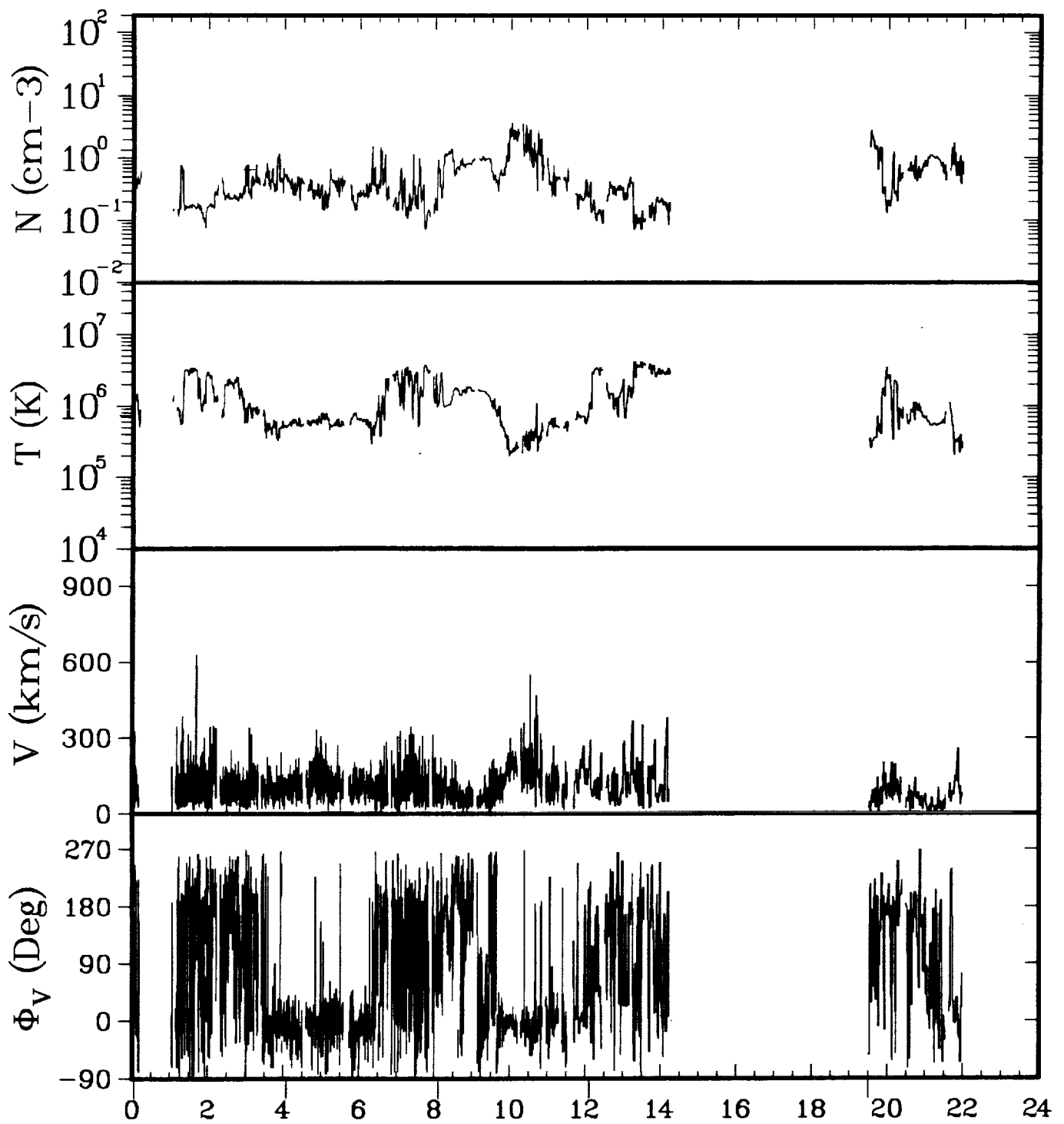

ISEE-3 ELECTRONS 04/19/83

GSEX	-37.2	-34.4	-31.3	-28.1	-21.4
Y	-17.2	-17.6	-18.0	-18.2	-18.3
Z	2.3	2.0	1.7	1.4	0.7
GSMY	-15.8	-17.1	-17.9	-18.2	-16.3
Z	-7.1	-4.8	-1.9	-1.7	-8.3

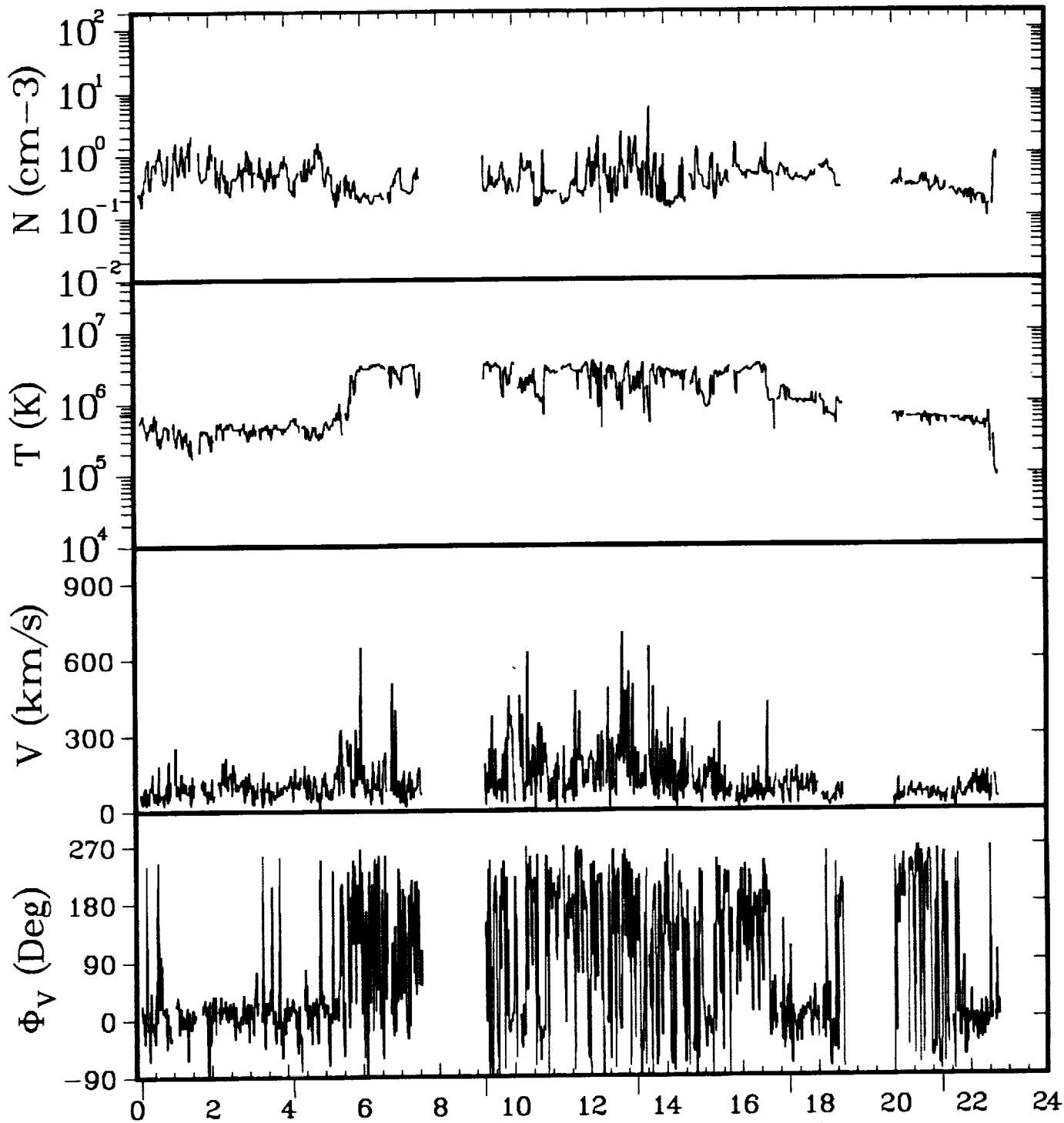

ISEE-3 ELECTRONS 04/20/83

GSEX	-16.7	-12.3	-6.0	-0.6	4.8	8.4
Y	-17.9	-17.2	-15.4	-12.9	-8.4	-1.2
Z	0.3	-0.1	-0.5	-0.9	-1.0	-0.9
GSMY	-15.4	-15.9	-15.1	-12.4	-7.3	-0.6
Z	-9.1	-6.5	-3.1	-3.3	-4.2	-1.4

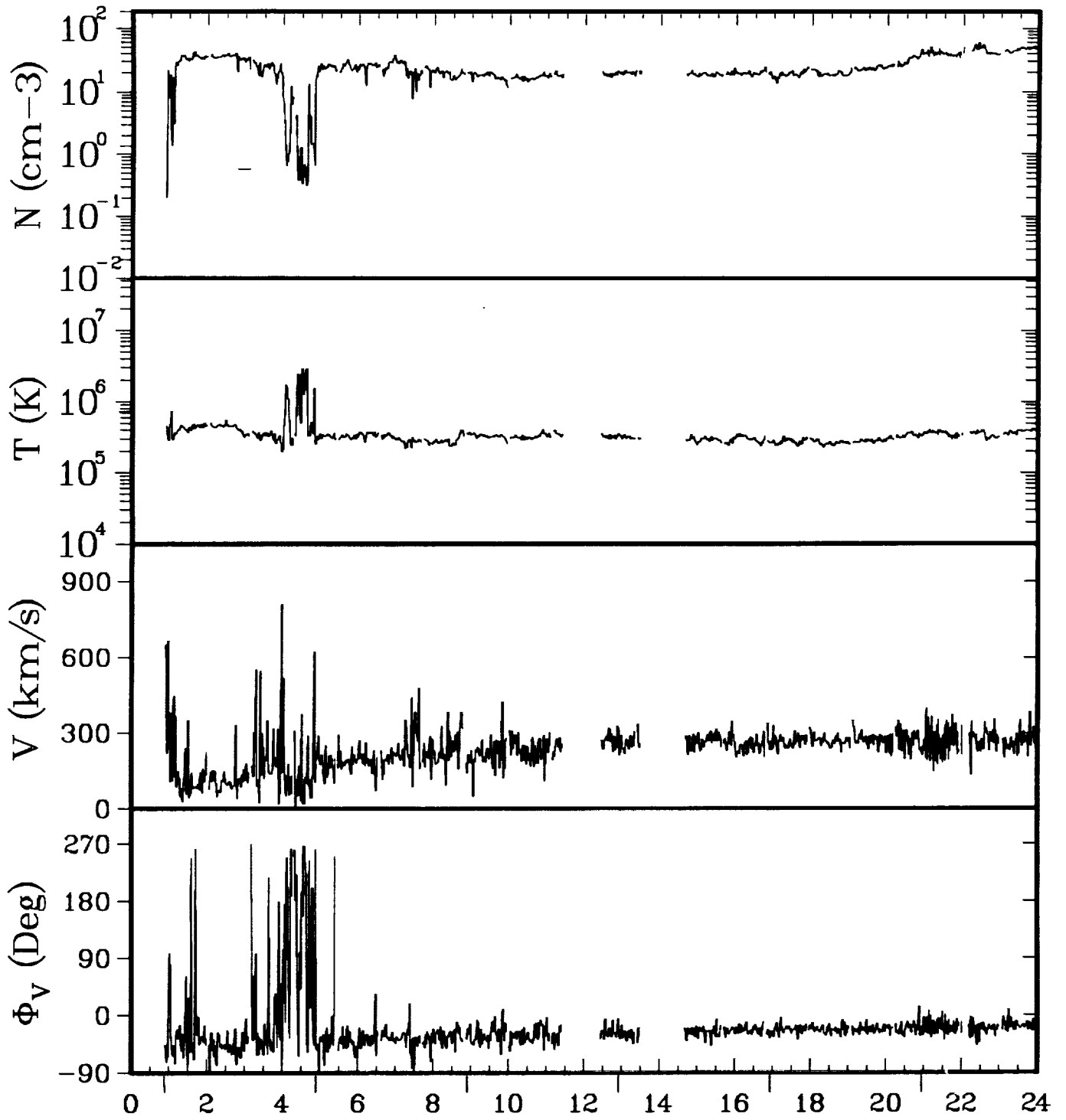

ISEE-3 ELECTRONS 04/21/83

GSEX	8.3	5.9	2.7	-0.7	-4.1	-7.4
Y	5.9	12.2	17.0	20.8	23.8	26.3
Z	-0.3	0.3	1.0	1.6	2.1	2.6
GSMY	5.2	11.4	16.6	20.2	21.4	21.1
Z	2.7	4.4	3.9	5.3	10.7	16.0

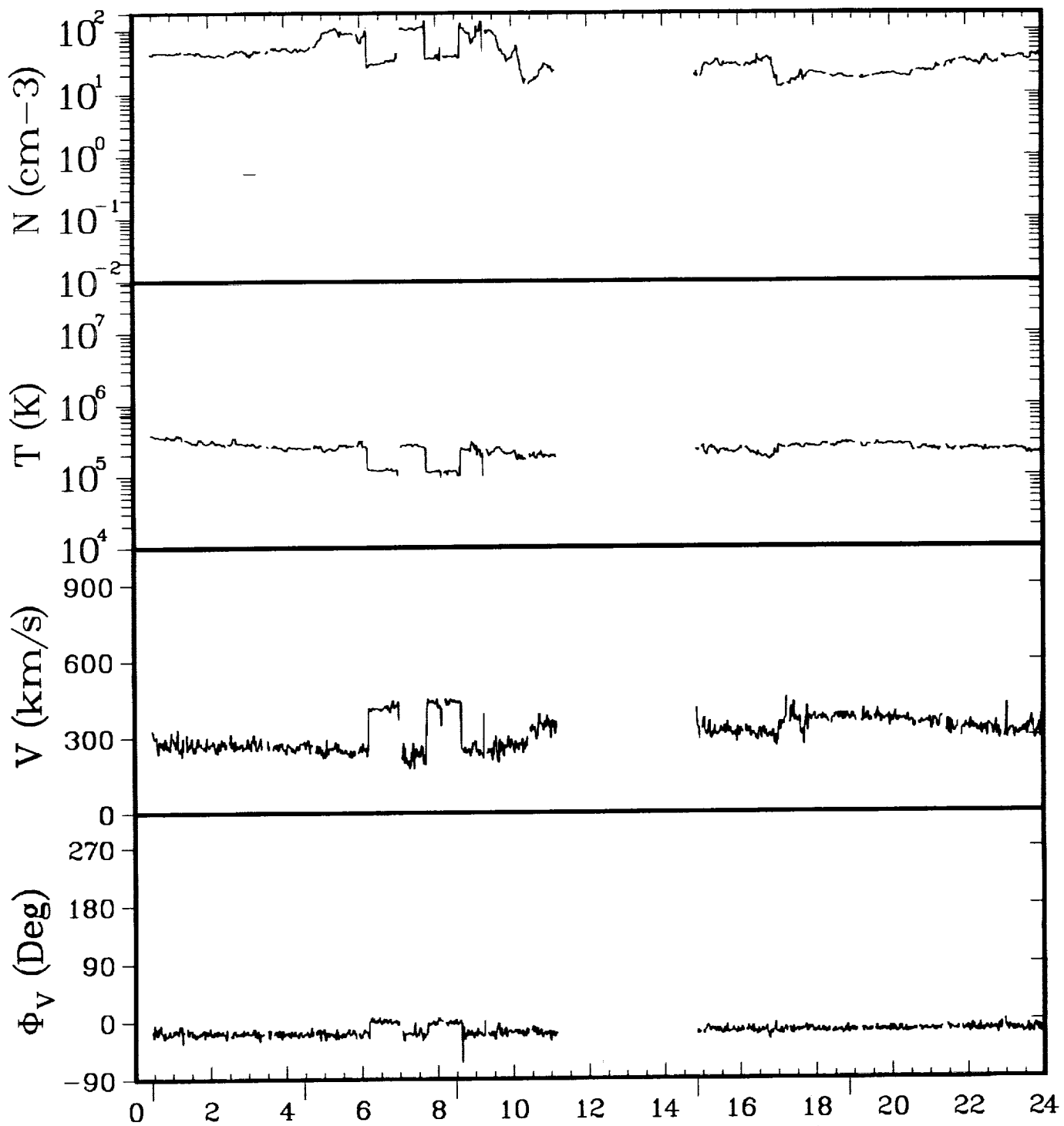

ISEE-3 ELECTRONS 04/22/83

GSEX	-10.1	-13.1	-16.1	-20.4	-23.1
Y	28.2	30.0	31.6	33.8	34.9
Z	3.0	3.4	3.8	4.4	4.7
GSMY	22.7	26.9	30.5	31.6	28.9
Z	17.0	13.8	9.4	12.7	20.2

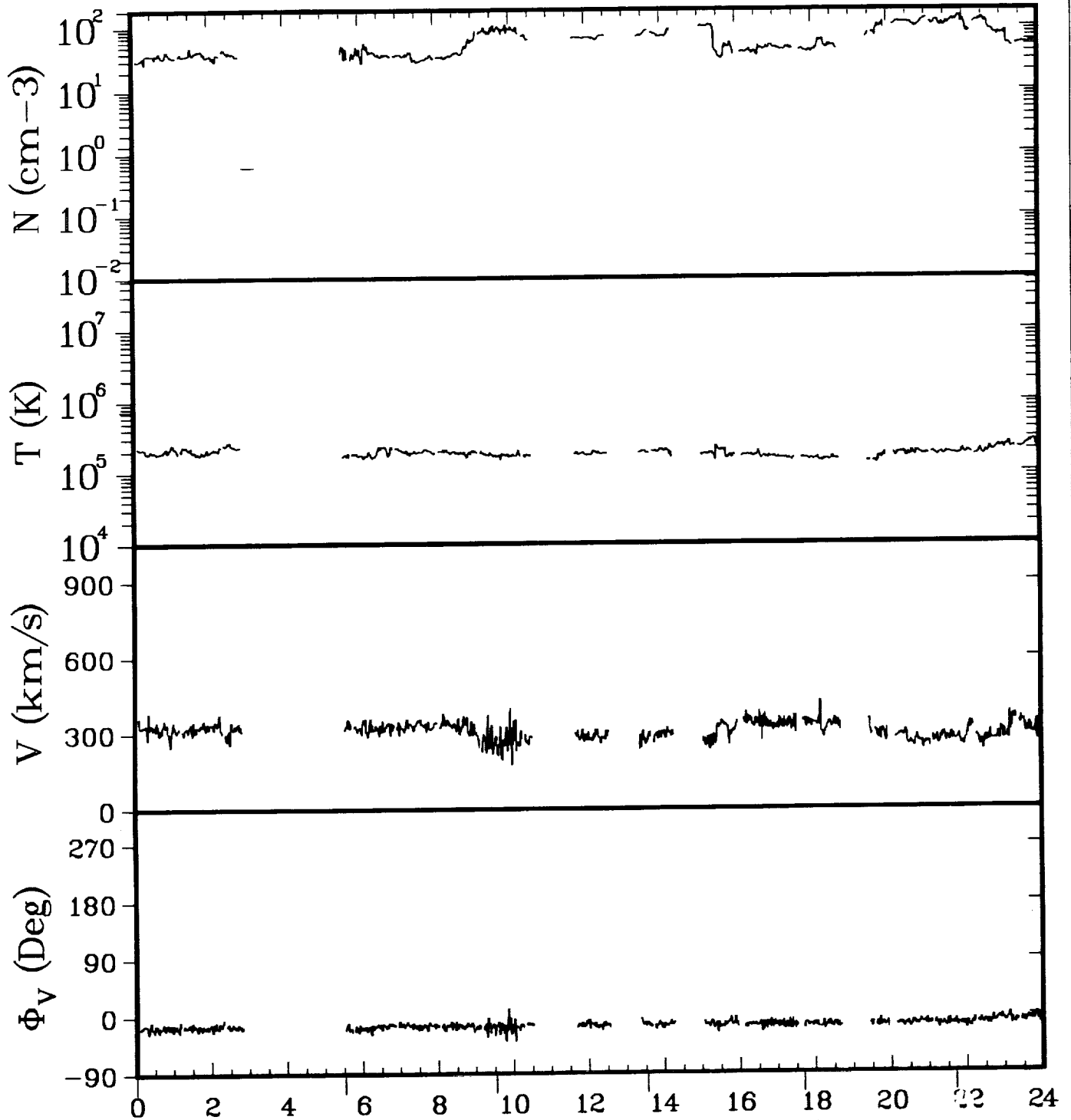

ISEE-3 ELECTRONS 04/23/83

GSEX	-26.3	-29.6	-31.9	-34.1	-36.5	-38.8
Y	36.2	37.4	38.2	39.0	39.7	40.4
Z	5.1	5.5	5.7	6.0	6.2	6.3
GSMY	28.3	34.1	36.9	37.1	33.9	31.0
Z	23.1	16.3	11.3	13.3	21.6	26.7

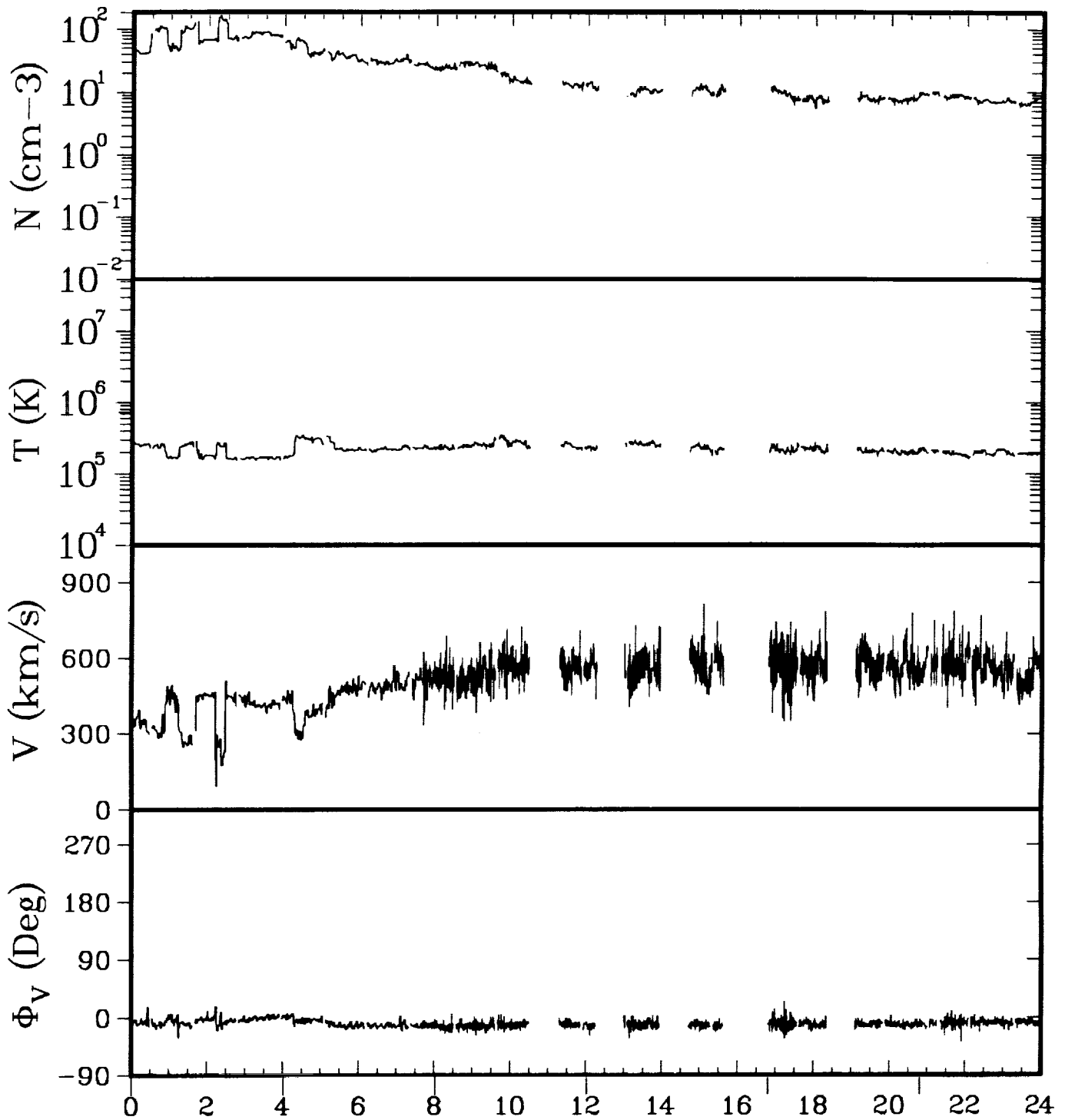

ISEE-3 ELECTRONS 04/24/83

GSEX	-40.2	-42.8	-45.5	-48.0	-51.0	-53.4
Y	40.8	41.3	41.6	41.8	41.8	41.7
Z	6.4	6.4	6.3	6.2	6.1	5.9
GSMY	31.7	36.1	39.7	40.4	37.0	32.8
Z	26.5	21.1	13.8	12.2	20.3	26.5

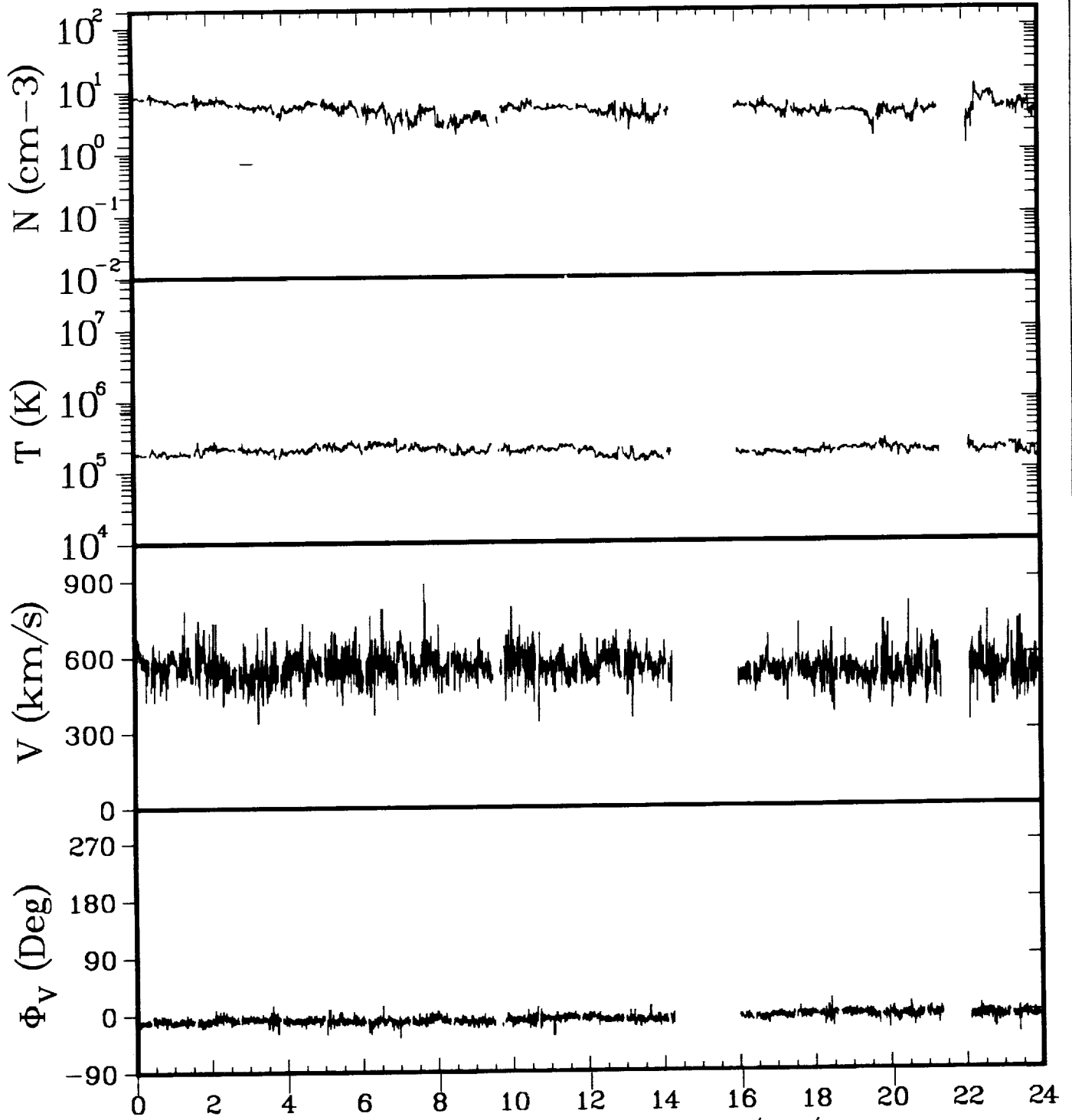

ISEE-3 ELECTRONS 04/25/83

GSEX	-55.3	-57.7	-59.9	-62.2	-64.3	-66.5
Y	41.7	41.5	41.3	41.1	40.9	40.6
Z	5.8	5.7	5.5	5.4	5.2	5.1
GSMY	32.8	36.6	39.7	40.0	37.3	32.9
Z	26.3	20.4	12.9	11.2	17.5	24.4

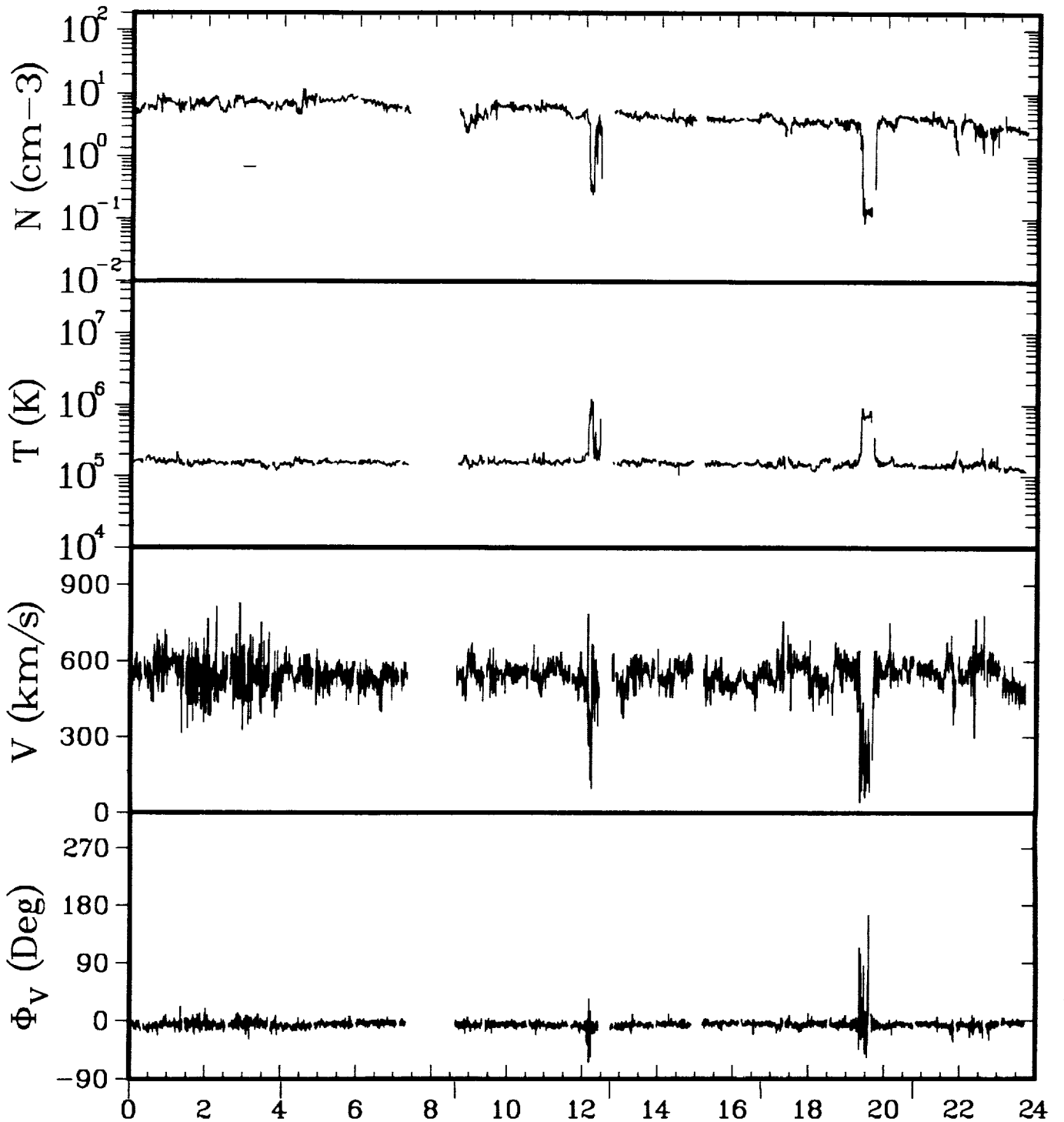

ISEE-3 ELECTRONS 04/26/83

GSEX	-68.5	-70.5	-72.8	-74.8	-76.7	-78.6
Y	40.4	40.1	39.7	39.3	39.0	38.6
Z	4.9	4.8	4.6	4.4	4.2	4.0
GSMY	32.2	35.7	38.5	38.2	35.2	31.3
Z	24.8	18.9	10.7	10.4	17.3	23.0

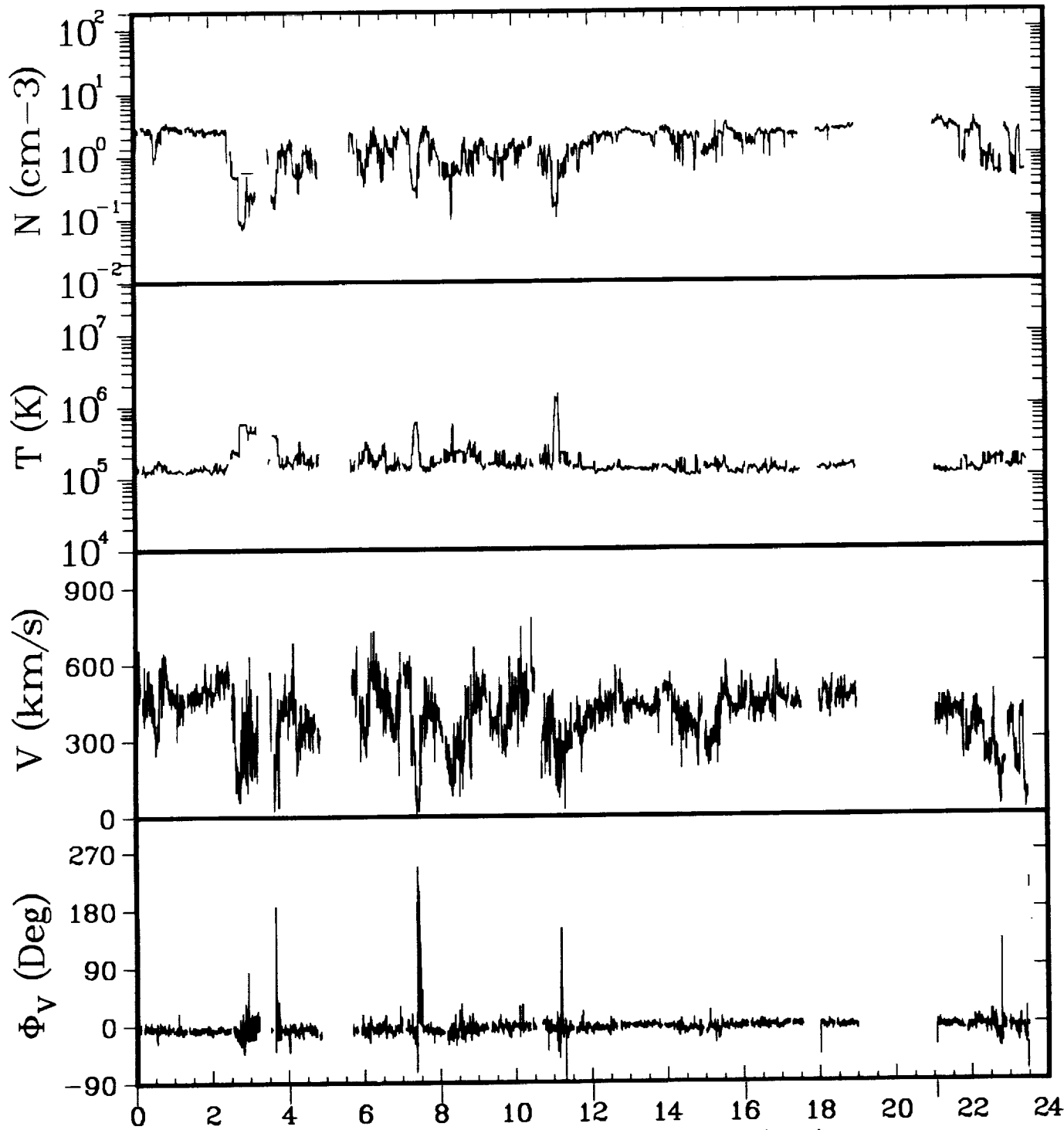

ISEE-3 ELECTRONS 04/27/83

GSEX	-80.1	-81.9	-83.7	-85.4	-87.1	-89.2
Y	38.3	37.9	37.5	37.1	36.7	36.2
Z	3.9	3.7	3.5	3.4	3.2	2.9
GSMY	31.1	34.1	36.4	36.4	34.1	29.7
Z	22.7	17.0	9.9	8.3	14.0	21.0

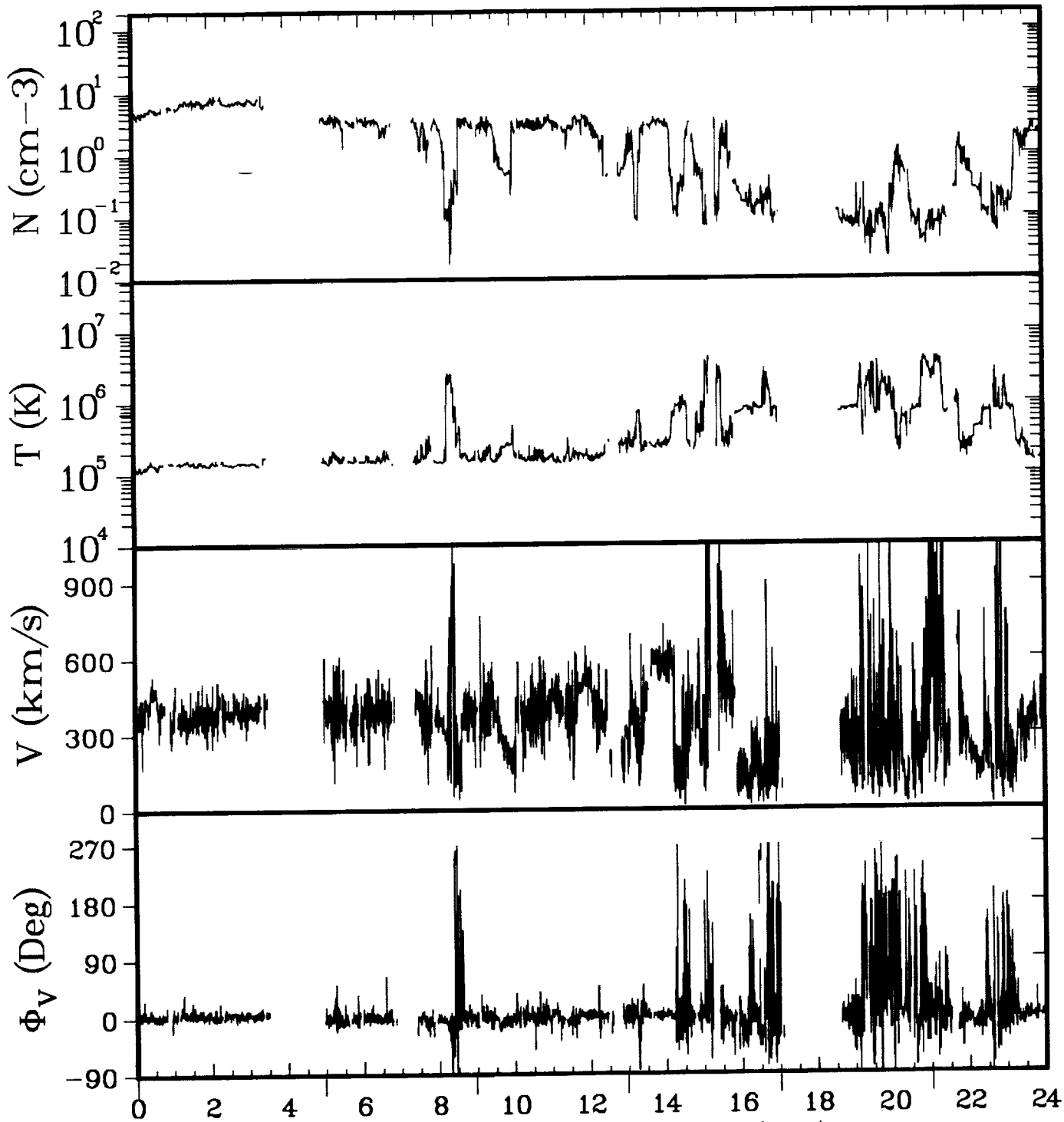

ISEE-3 ELECTRONS 04/29/83

GSEX	-99.7	-101.5	-102.9	-104.3	-105.7	-107.1
Y	33.4	32.8	32.4	32.0	31.5	31.1
Z	1.7	1.4	1.2	1.0	0.9	0.7
GSMY	28.1	30.9	31.9	31.5	29.3	26.6
Z	18.1	11.3	5.6	5.8	11.7	16.2

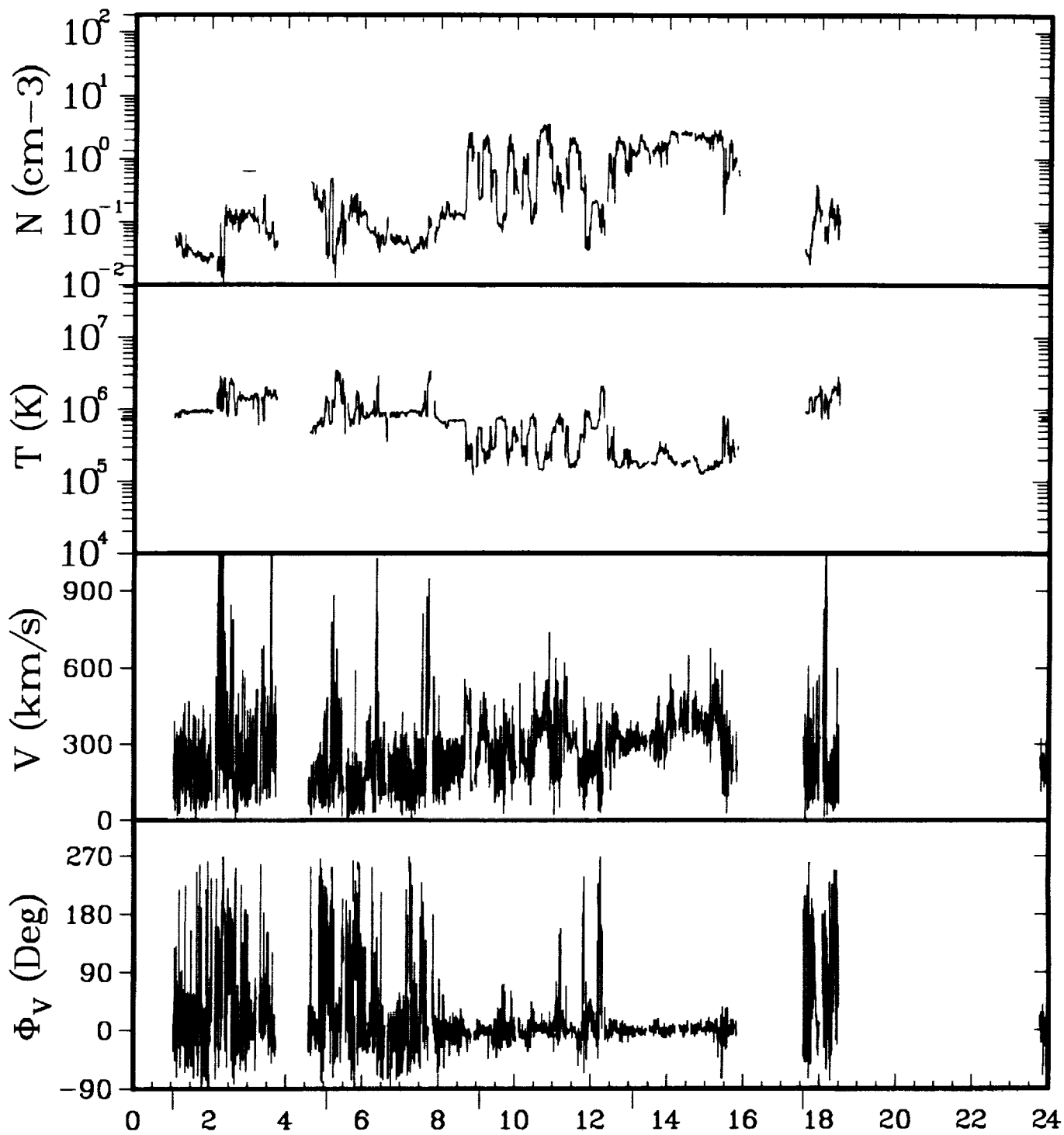

ISEE-3 ELECTRONS 04/30/83

GSEX	-108.4	-109.8	-111.1	-112.4	-113.8
Y	30.7	30.2	29.8	29.4	28.9
Z	0.5	0.3	0.1	-0.1	-0.3
GSMY	26.9	28.8	29.6	29.1	26.9
Z	14.8	9.1	3.9	4.2	10.5

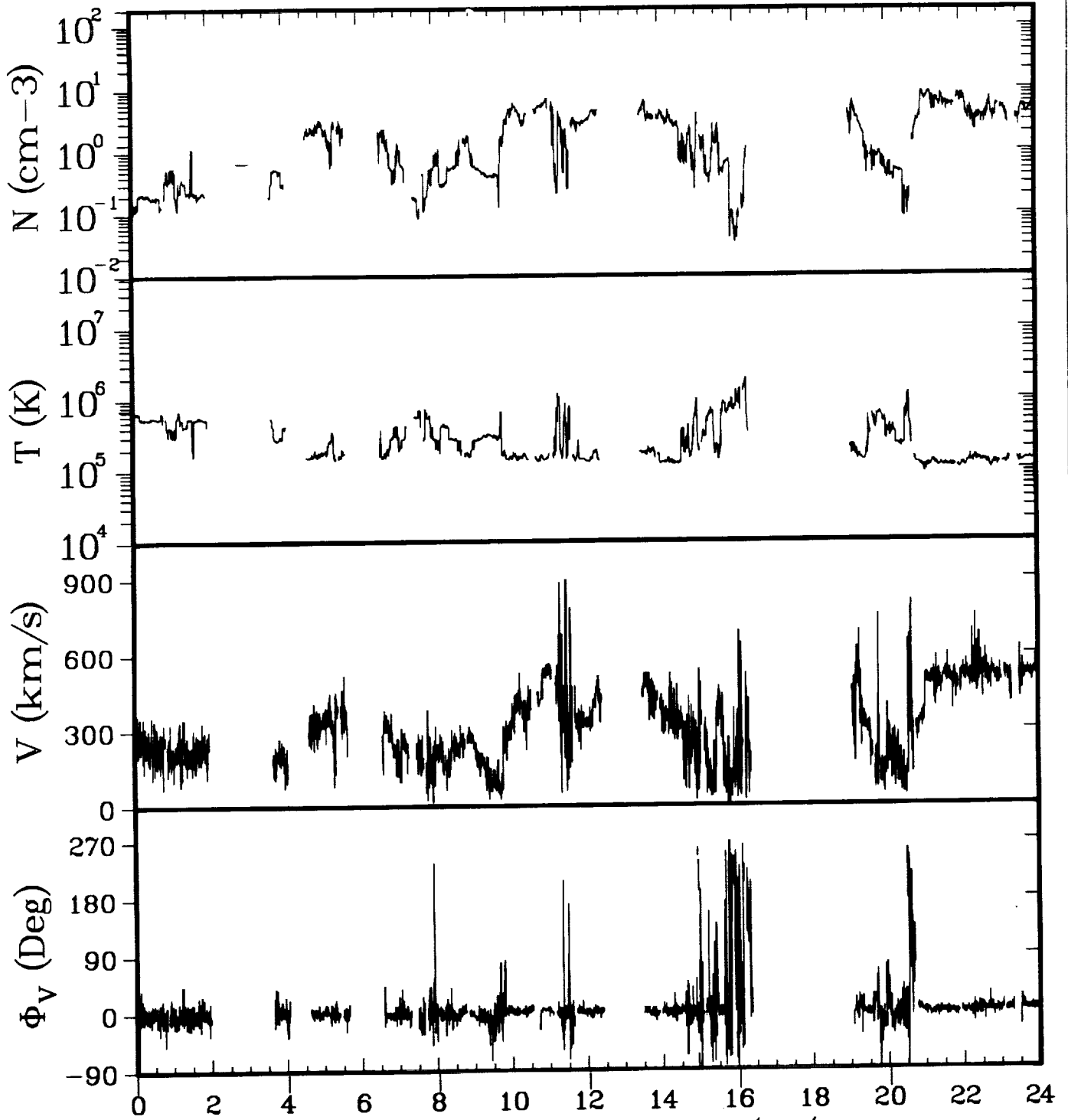

ISEE-3 ELECTRONS 05/01/83

GSEX	-115.8	-117.0	-118.2	-119.4	-120.5	-121.7
Y	28.2	27.8	27.4	27.0	26.5	26.1
Z	-0.6	-0.8	-1.0	-1.2	-1.4	-1.6
GSMY	24.9	26.4	27.2	26.9	25.9	23.8
Z	13.3	8.7	3.2	1.9	6.2	10.9

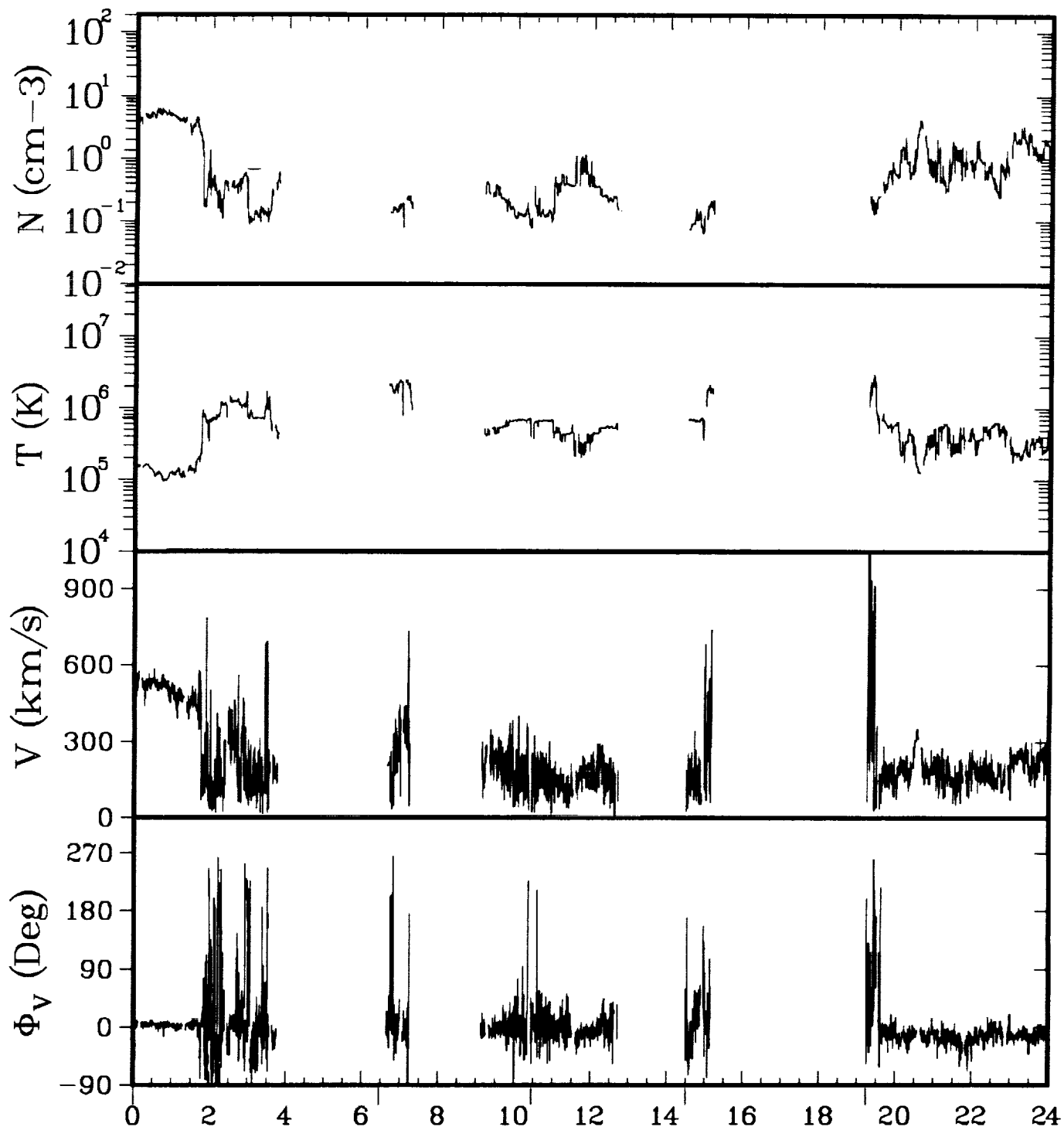

ISEE-3 ELECTRONS 05/02/83

GSEX	-122.8	-124.6	-125.7	-126.8	-128.0
Y	25.7	25.1	24.7	24.3	23.8
Z	-1.8	-2.1	-2.3	-2.5	-2.7
GSMY	23.3	24.9	24.8	24.3	22.5
Z	11.0	3.3	0.2	2.3	8.1

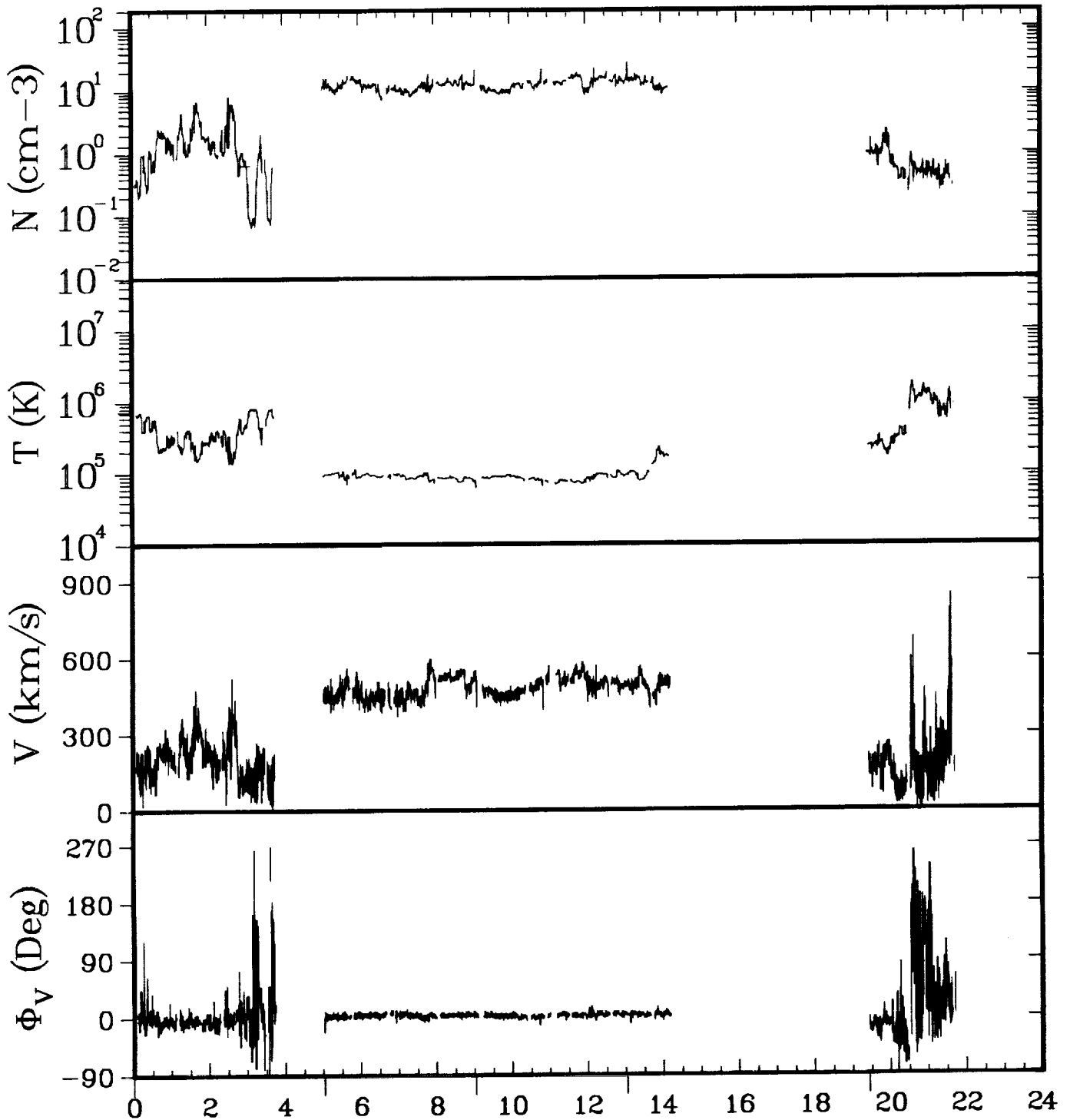

ISEE-3 ELECTRONS 05/03/83

GSEX	-129.3	-130.6	-131.6	-132.6	-134.2
Y	23.3	22.8	22.5	22.1	21.5
Z	-2.9	-3.2	-3.4	-3.5	-3.8
GSMY	21.8	22.8	22.7	22.4	20.9
Z	8.8	3.4	-0.7	-0.6	6.1

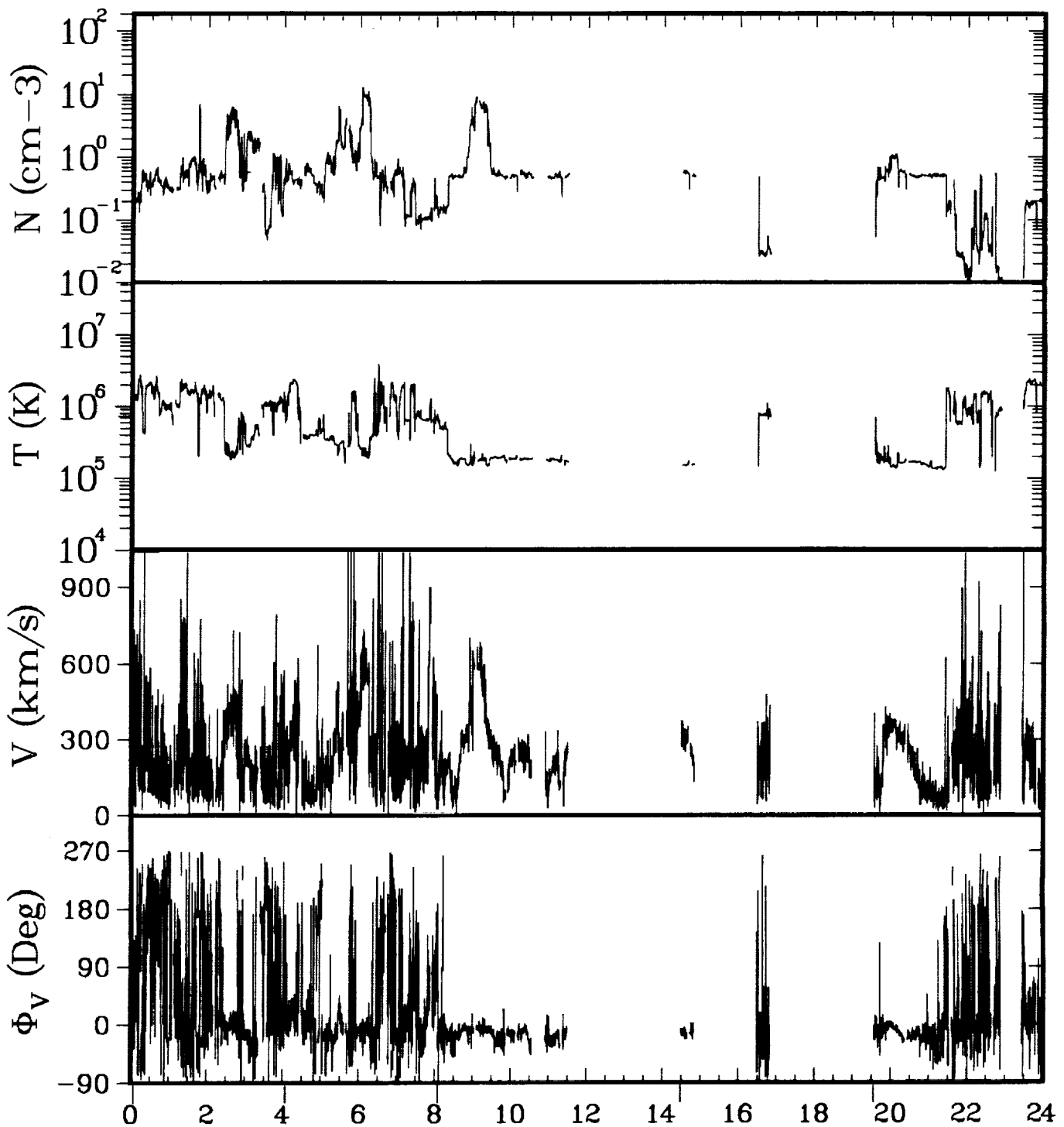

ISEE-3 ELECTRONS 05/04/83

GSEX	-135.3	-136.3	-137.2	-138.7	-139.8
Y	21.1	20.7	20.3	19.7	19.3
Z	-4.1	-4.2	-4.4	-4.7	-4.9
GSMY	20.4	20.9	20.7	20.3	19.5
Z	6.5	2.7	-1.6	-1.0	4.2

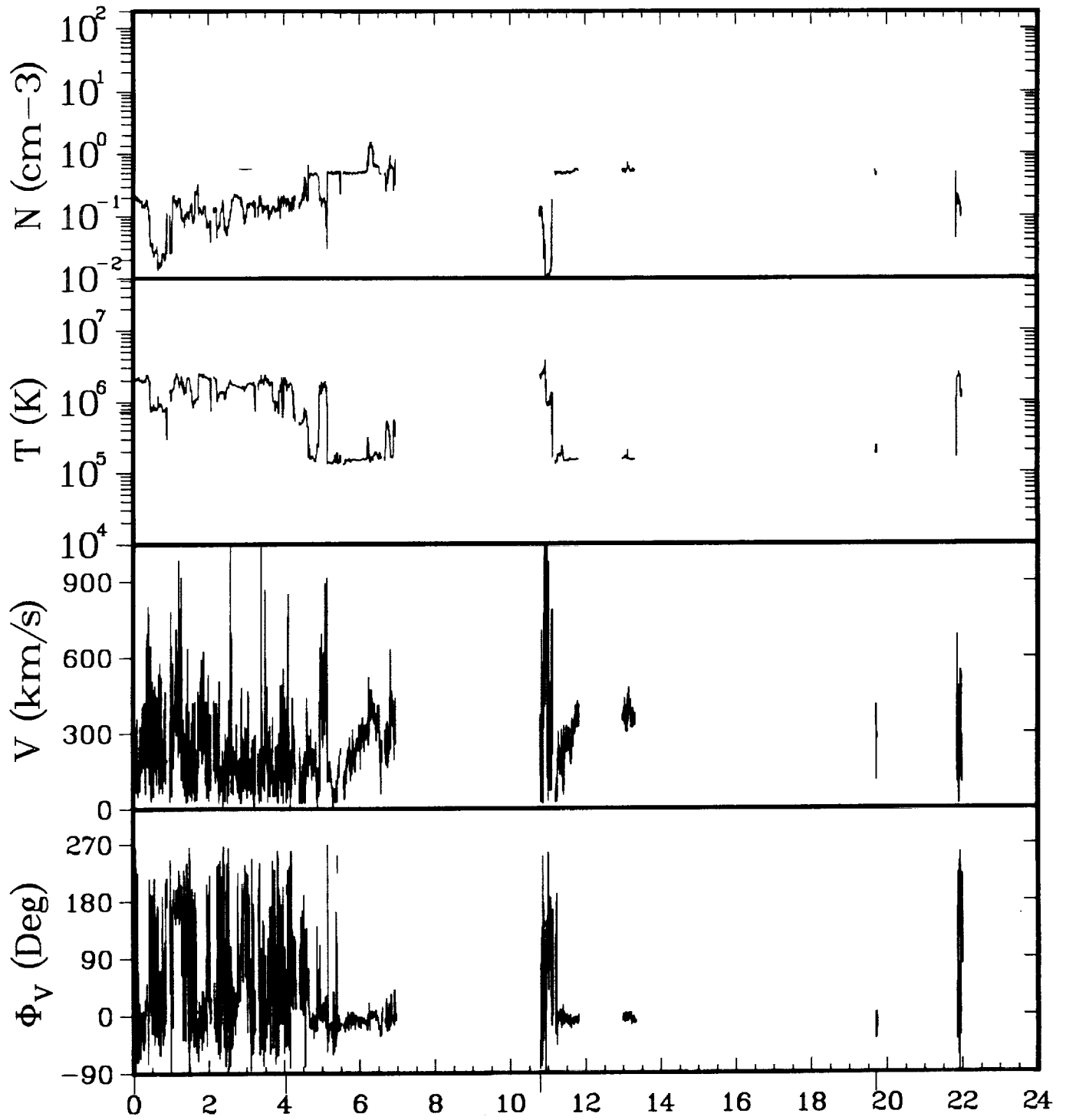

ISEE-3 ELECTRONS 05/05/83

GSEX	-140.8	-141.7	-143.2	-145.1
Y	18.9	18.6	18.0	17.3
Z	-5.2	-5.3	-5.6	-6.0
GSMY	19.1	19.3	18.4	18.1
Z	4.5	1.0	-4.1	2.3

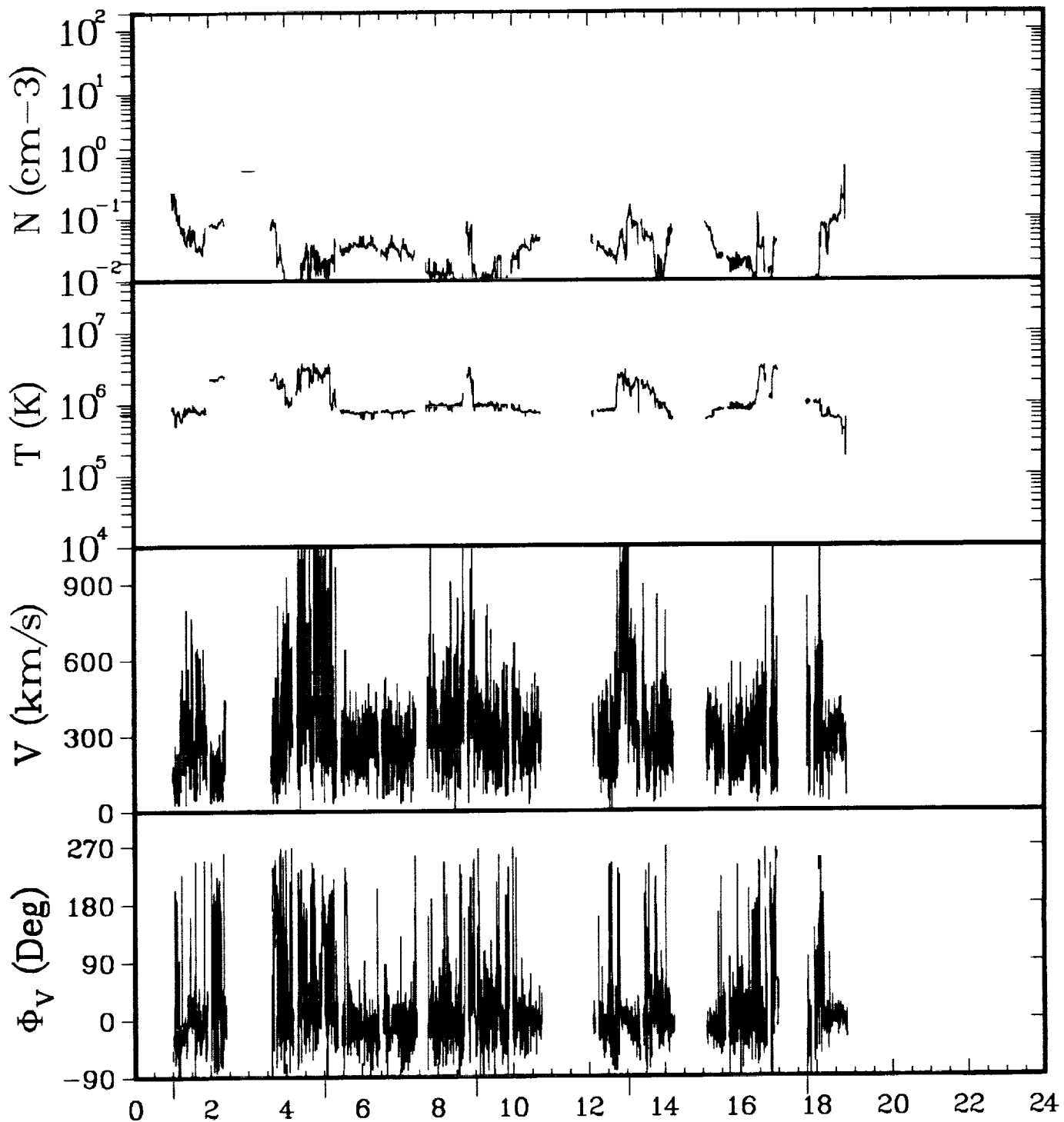

ISEE-3 ELECTRONS 05/06/83

GSEX	-146.2	-147.1	-147.9	-148.7	-149.7
Y	16.8	16.5	16.2	15.9	15.5
Z	-6.3	-6.5	-6.6	-6.8	-7.0
GSMY	17.8	17.6	16.8	16.6	17.0
Z	1.9	-1.8	-4.9	-4.9	-1.0

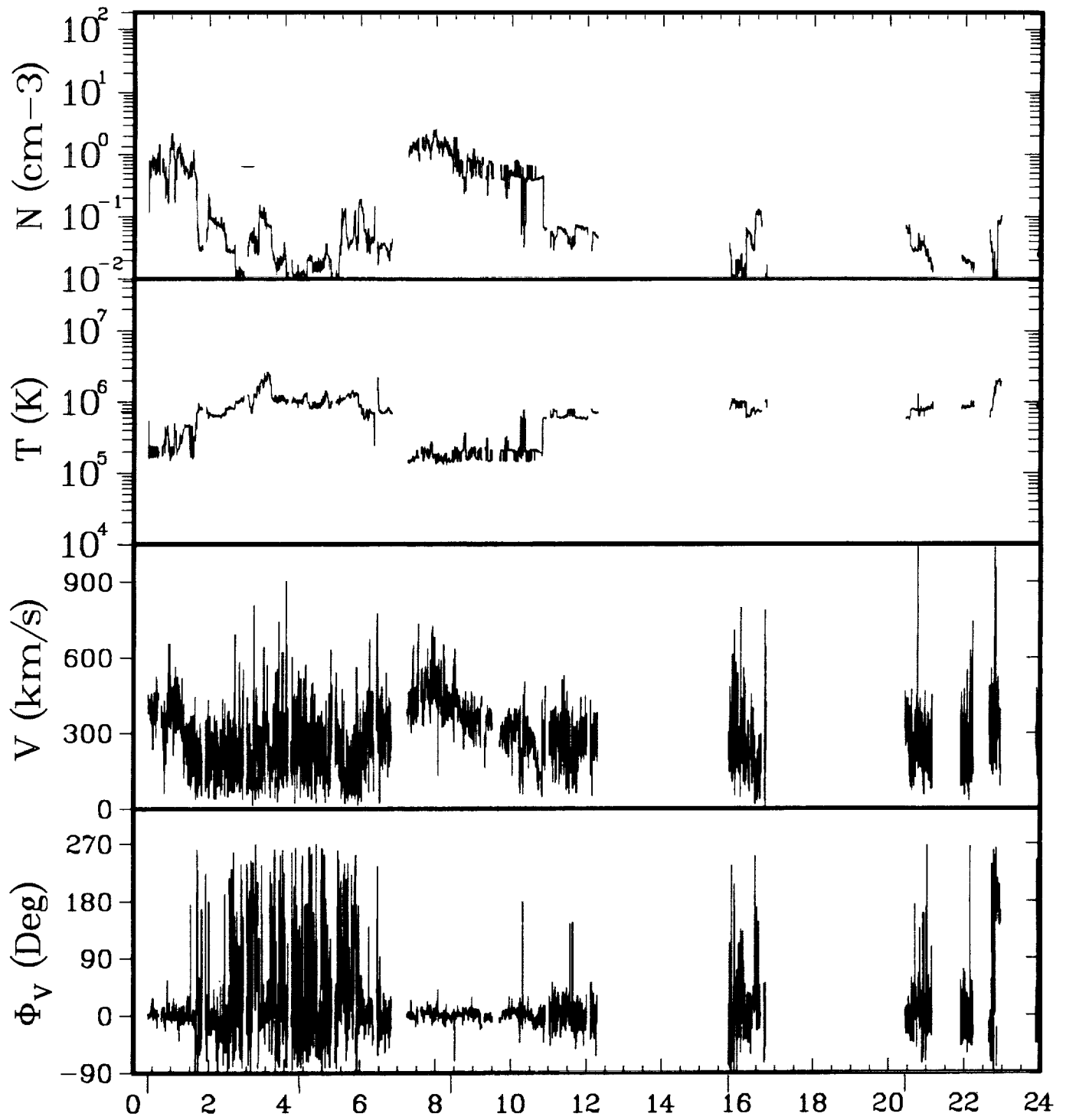

ISEE-3 ELECTRONS 05/07/83

GSEX	-151.0	-151.7	-152.5	-153.9	-154.8
Y	15.0	14.7	14.4	13.9	13.6
Z	-7.3	-7.5	-7.6	-8.0	-8.2
GSMY	16.7	16.3	15.2	15.4	15.8
Z	0.4	-2.8	-6.0	-4.4	-1.0

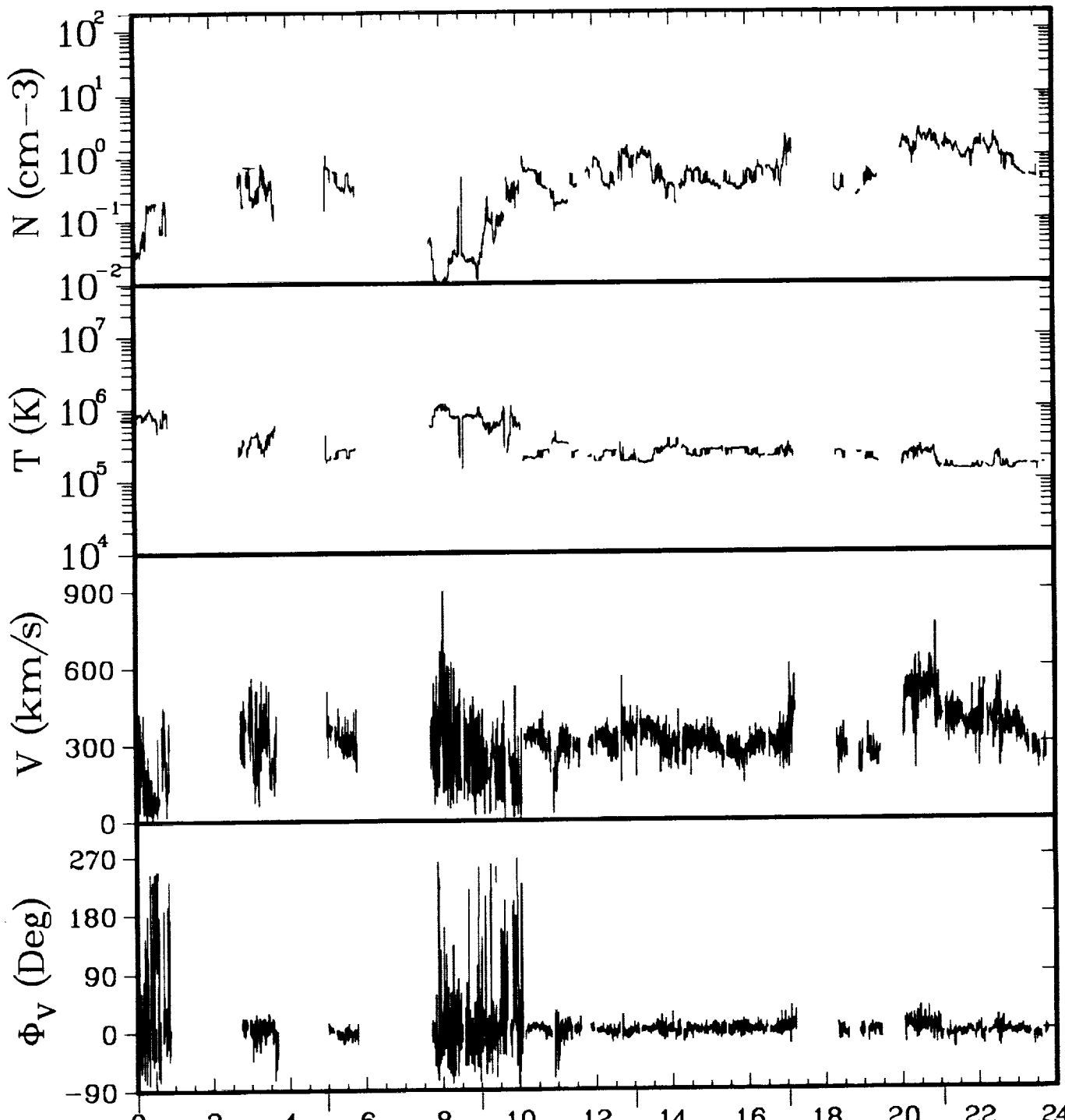

ISEE-3 ELECTRONS 05/08/83

GSEX	-155.4	-156.3	-157.1	-157.8	-158.5	-159.2
Y	13.3	13.0	12.7	12.4	12.2	11.9
Z	-8.3	-8.5	-8.7	-8.8	-9.0	-9.2
GSMY	15.6	14.7	13.4	13.3	14.4	14.8
Z	-1.2	-4.8	-7.5	-7.5	-4.8	-2.5

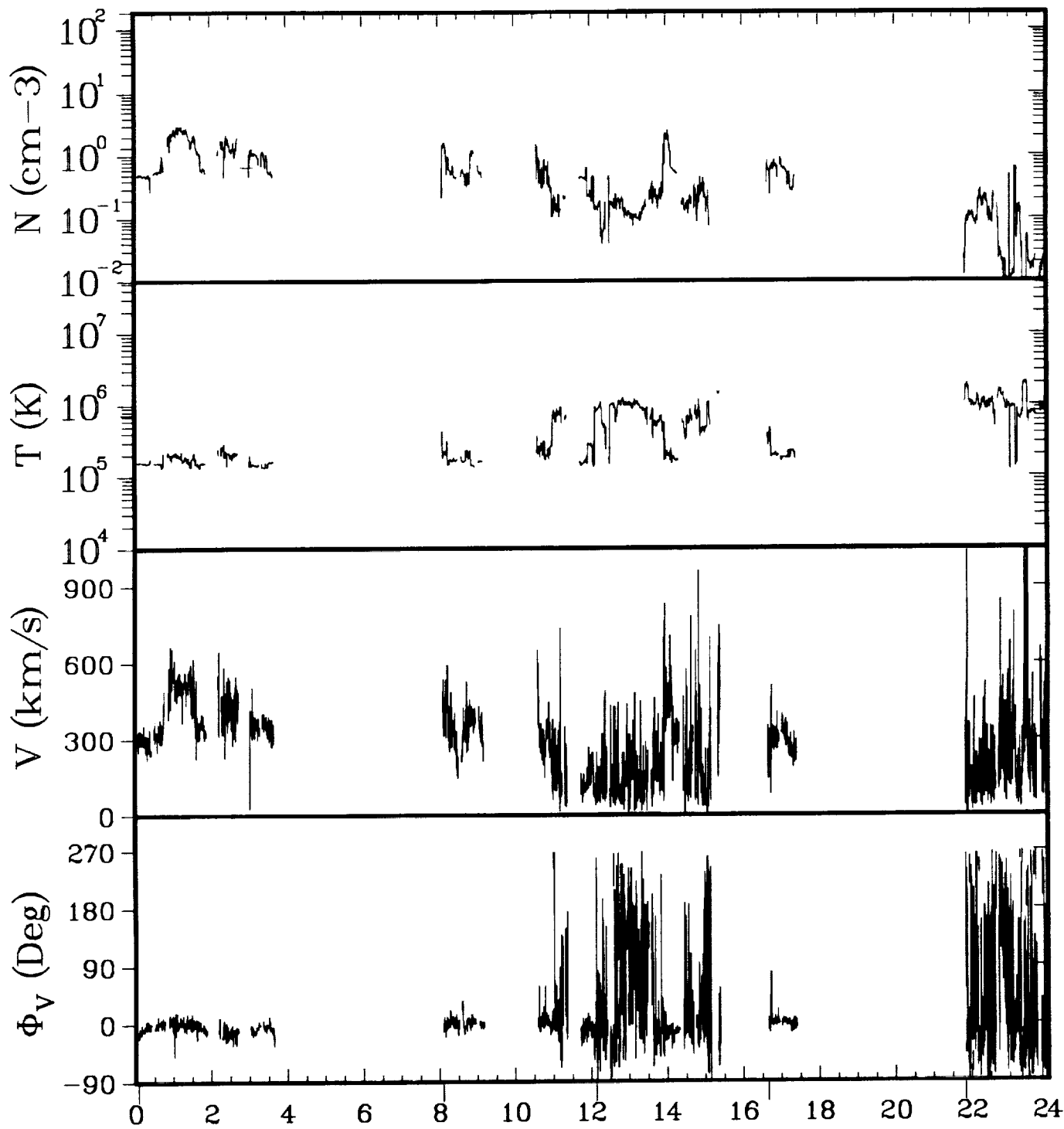

ISEE-3 ELECTRONS 05/09/83

GSEX	-159.7	-161.1	-161.8	-162.6	-163.4
Y	11.7	11.2	11.0	10.7	10.4
Z	-9.3	-9.6	-9.8	-10.0	-10.2
GSMY	14.7	12.2	11.7	13.1	14.0
Z	-2.9	-8.3	-8.9	-6.5	-4.0

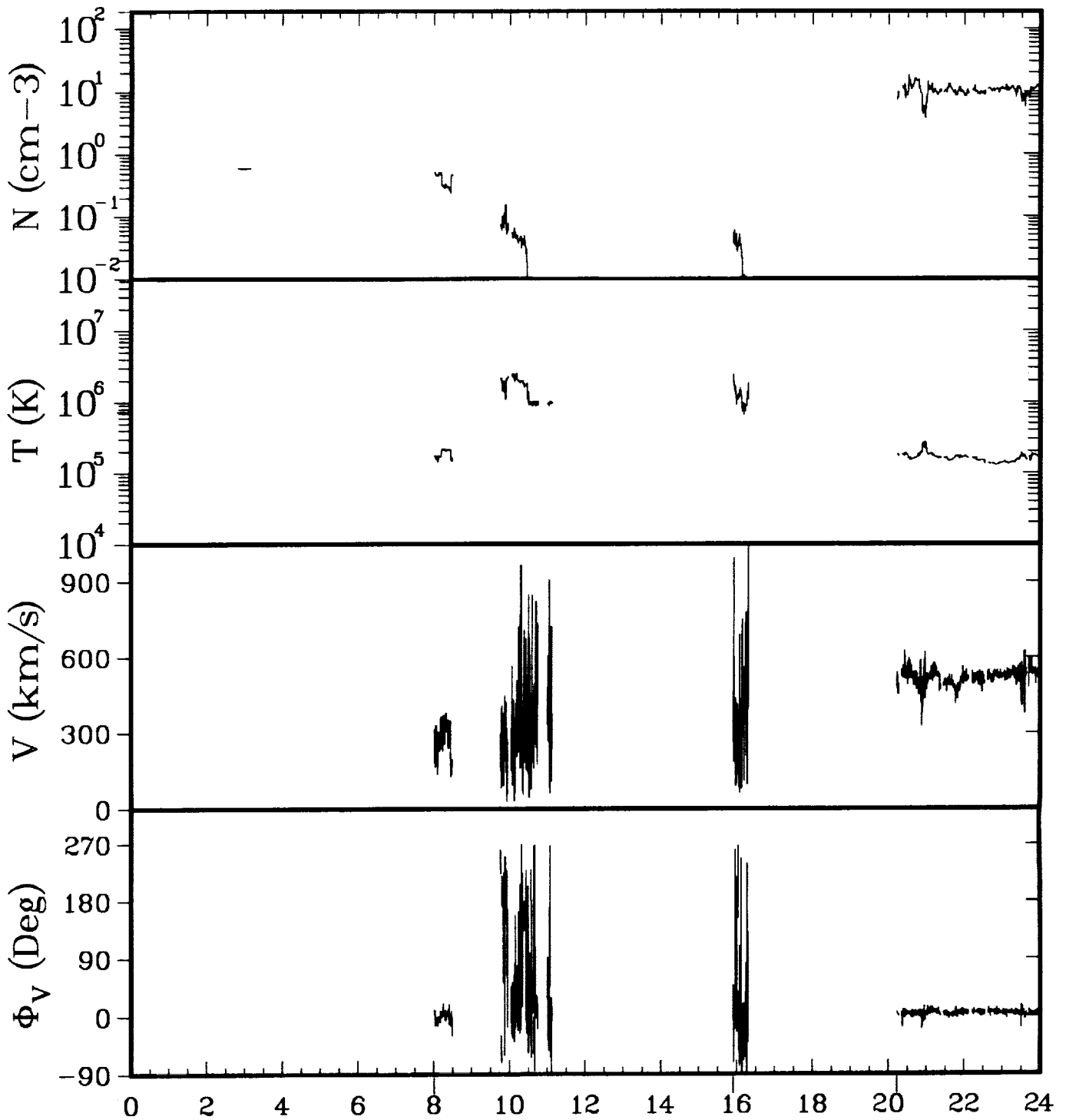

ISEE-3 ELECTRONS 05/10/83

GSEX	-165.1	-166.3	-167.0
Y	9.8	9.4	9.1
Z	-10.6	-10.9	-11.0
GSMY	10.9	11.6	13.1
Z	-9.4	-8.4	-5.8

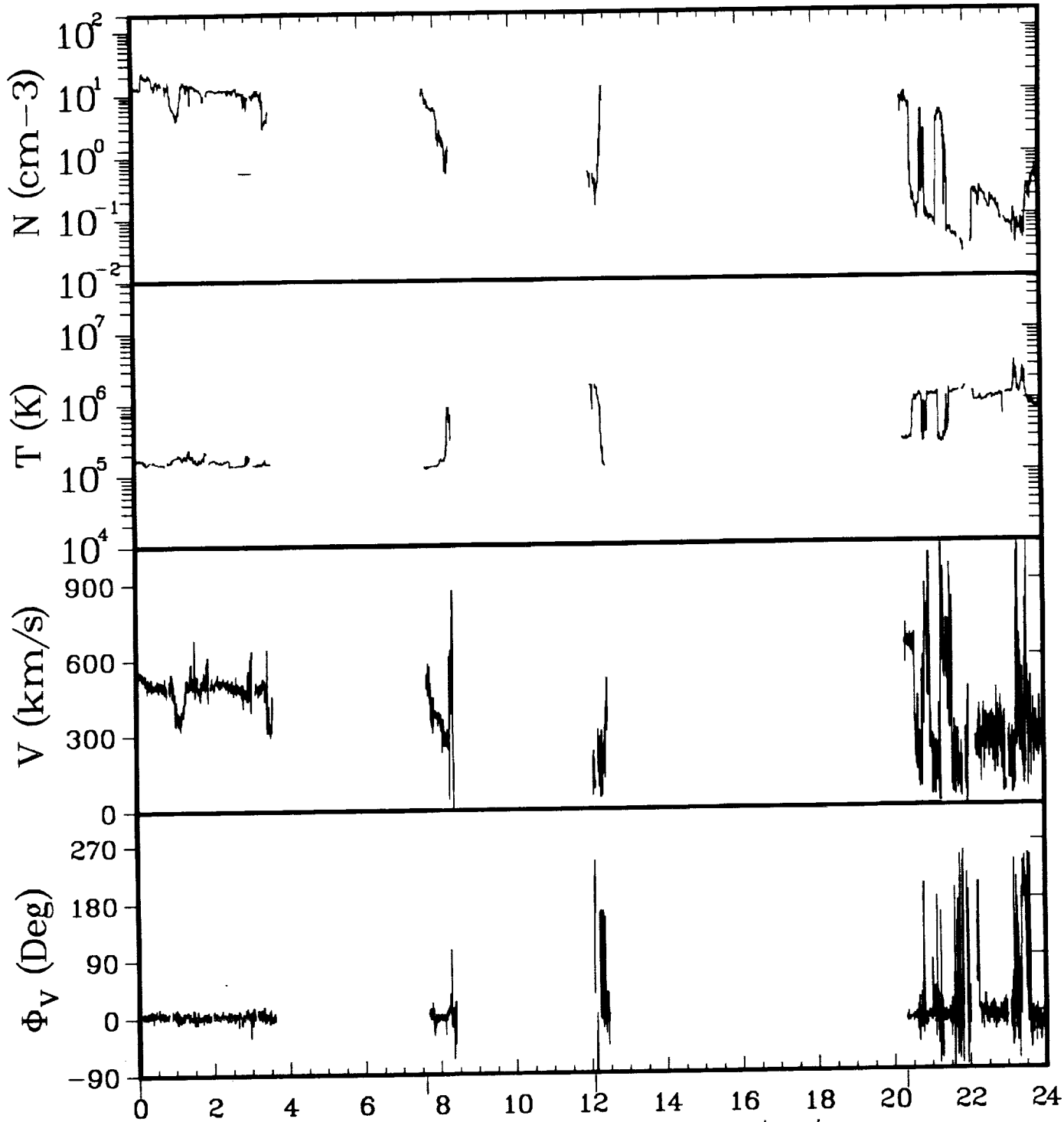

ISEE-3 ELECTRONS 05/11/83

GSEX	-167.6	-168.8	-169.5	-170.7
Y	8.9	8.5	8.3	7.9
Z	-11.2	-11.5	-11.6	-11.9
GSMY	13.0	9.9	9.0	12.3
Z	-5.9	-10.3	-11.1	-7.2

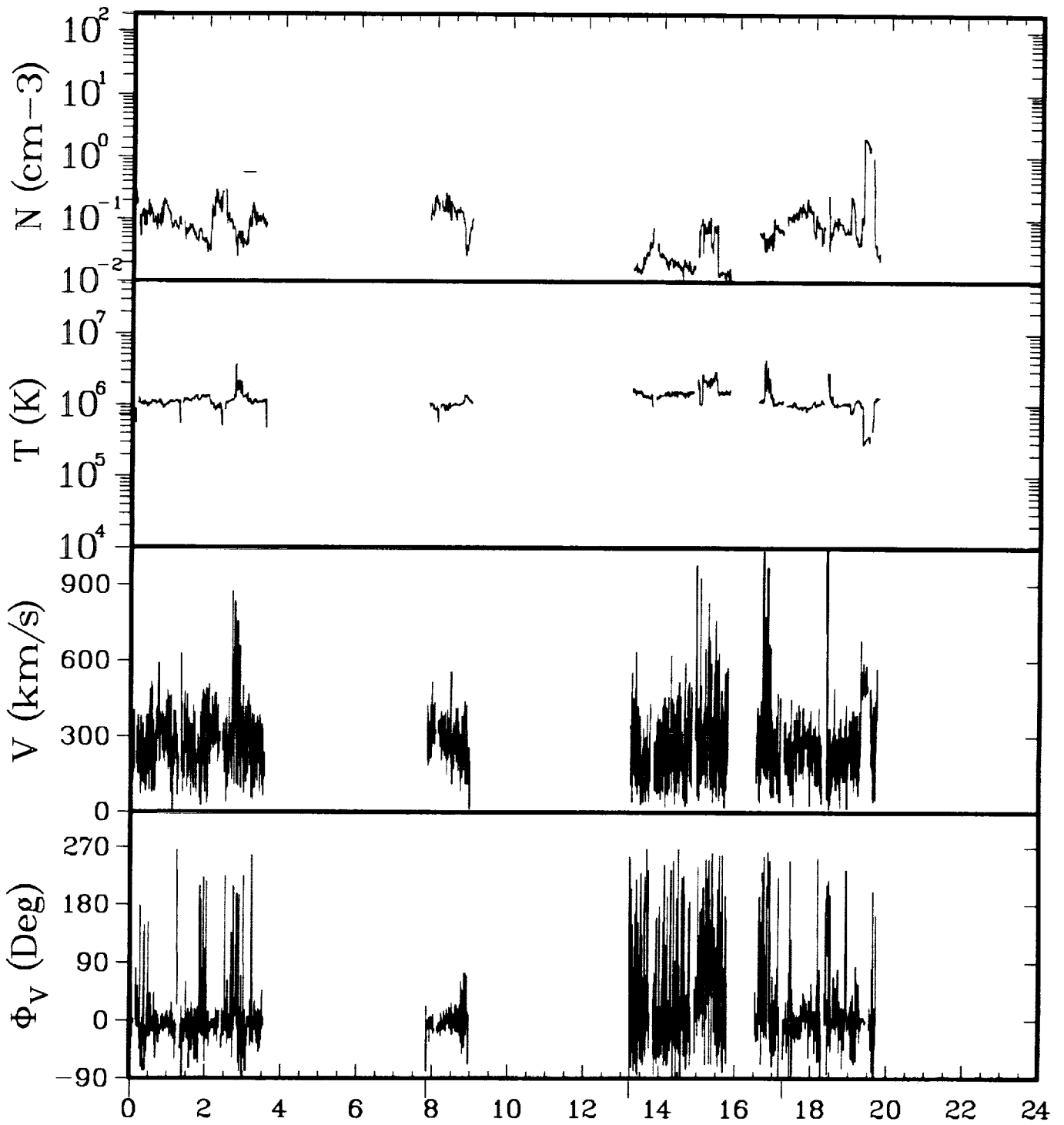

ISEE-3 ELECTRONS 05/12/83

GSEX	-171.3	-172.4	-173.2	-173.8
Y	7.7	7.3	7.1	6.9
Z	-12.1	-12.4	-12.5	-12.7
GSMY	12.3	8.6	8.2	10.4
Z	-7.4	-11.5	-11.9	-10.0

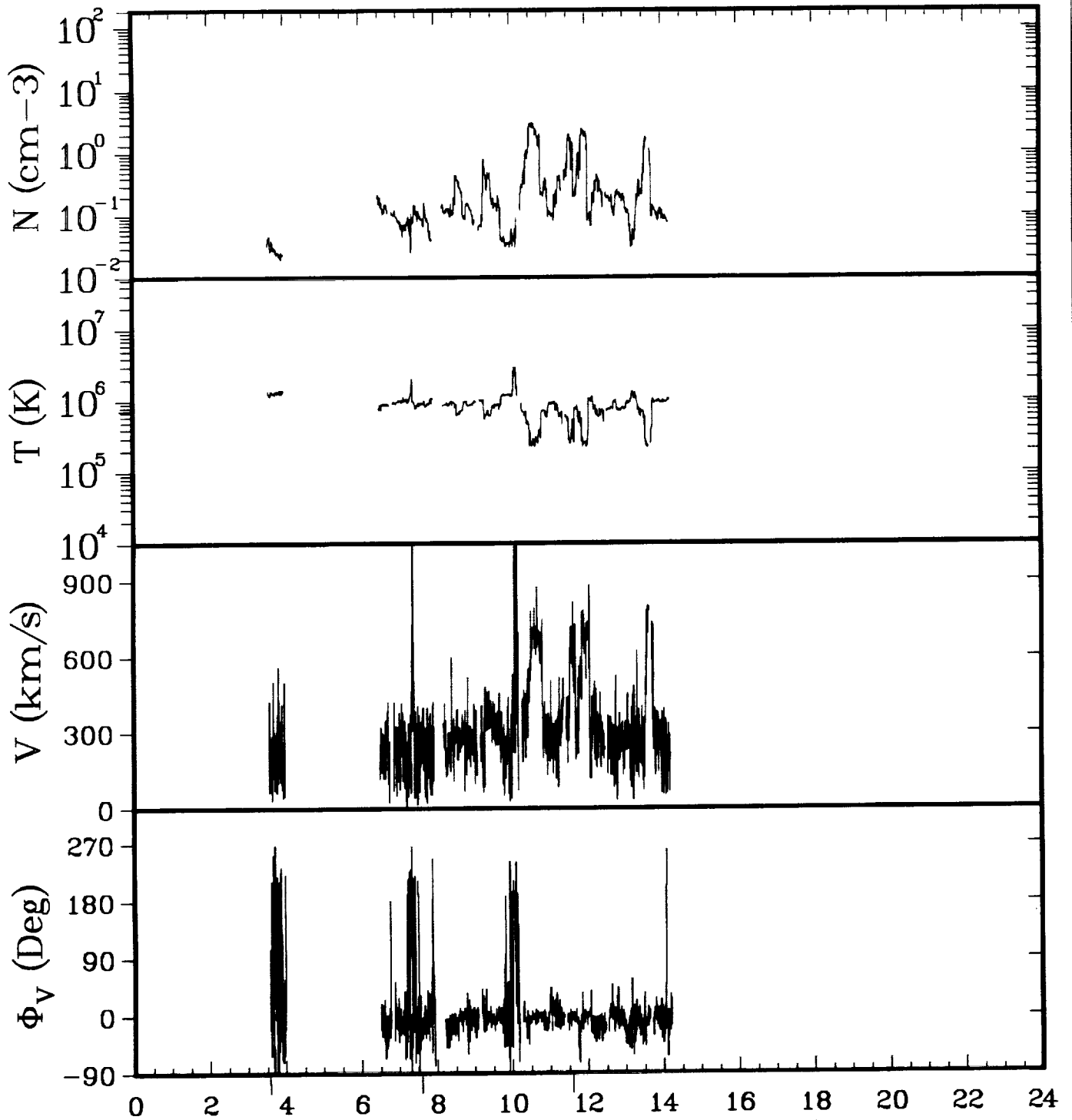

ISEE-3 ELECTRONS 05/13/83

GSEX	-175.3	-175.8	-176.4
Y	6.4	6.3	6.1
Z	-13.1	-13.2	-13.3
GSMY	10.2	7.7	6.7
Z	-10.4	-12.4	-13.0

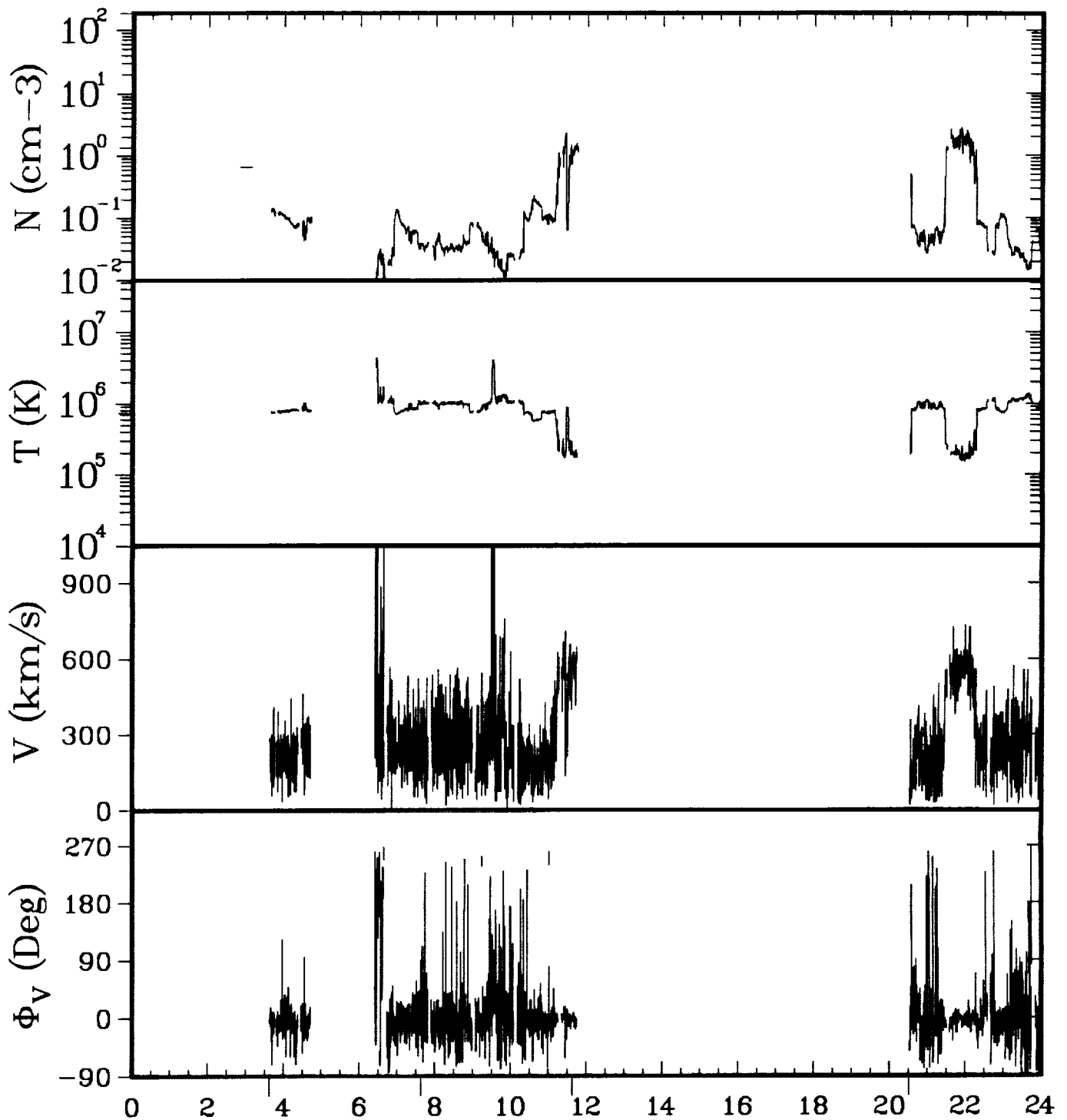

ISEE-3 ELECTRONS 05/14/83

GSEX	-178.6	-179.2	-179.7	-180.9
Y	5.4	5.3	5.1	4.8
Z	-13.9	-14.0	-14.1	-14.4
GSMY	9.4	6.7	5.7	10.6
Z	-11.6	-13.4	-13.9	-10.9

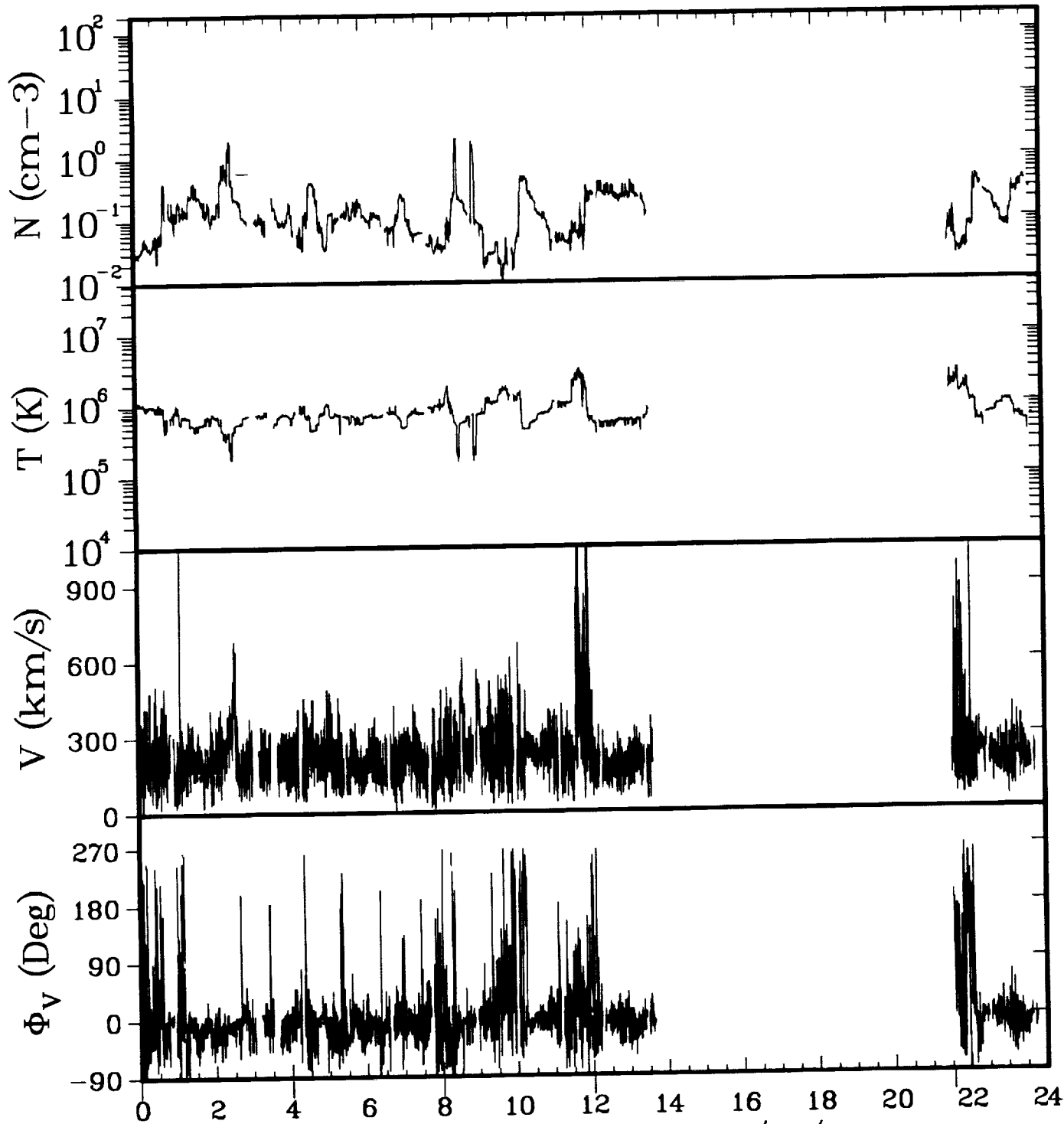

ISEE-3 ELECTRONS 05/15/83

GSEX	-181.3	-181.8	-182.4	-182.9	-184.1
Y	4.7	4.5	4.4	4.2	3.9
Z	-14.6	-14.7	-14.8	-14.9	-15.2
GSMY	10.5	8.4	5.6	4.9	10.3
Z	-11.1	-12.9	-14.4	-14.7	-11.9

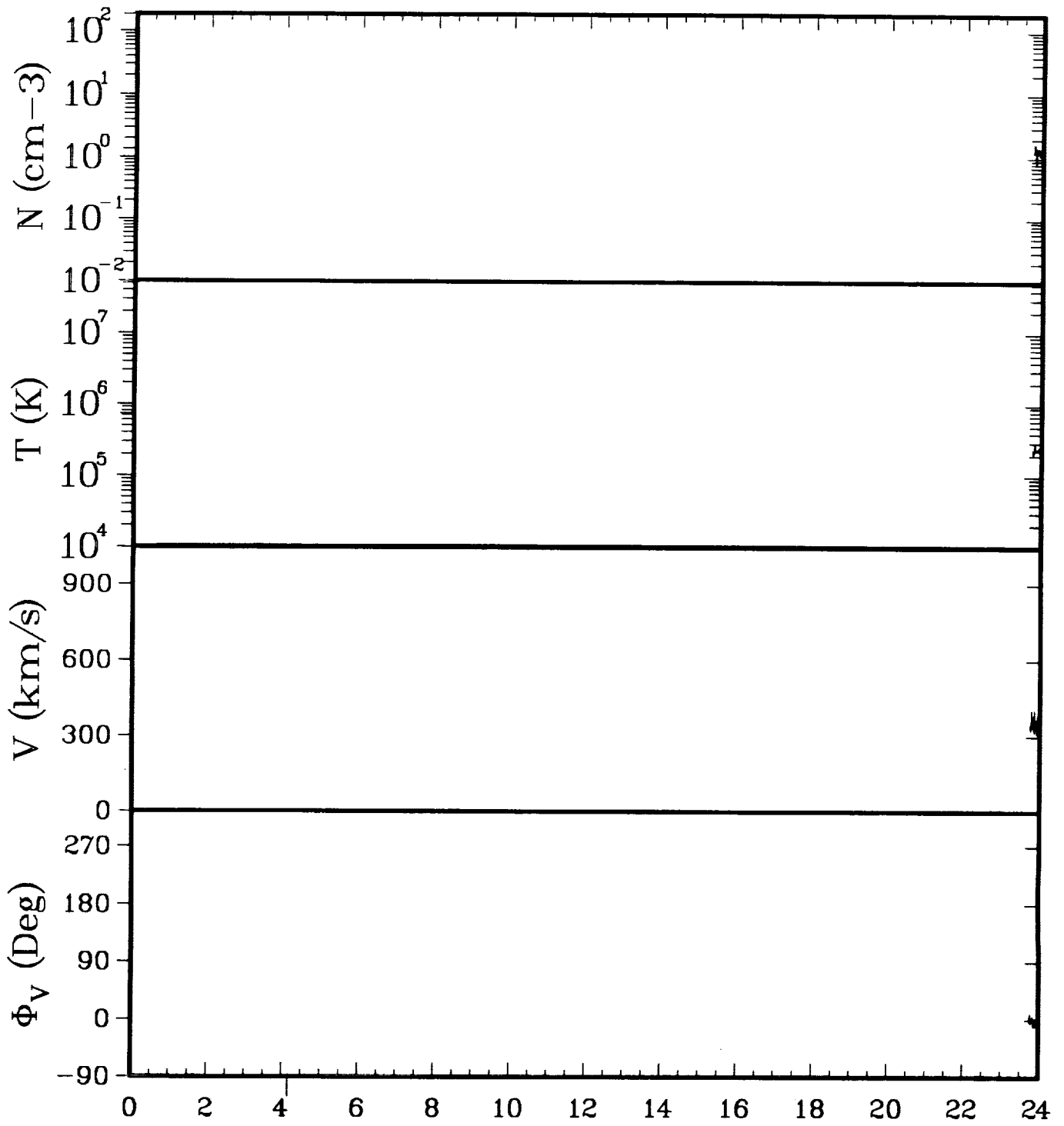

ISEE-3 ELECTRONS 05/16/83

GSEX	-184.9
Y	3.7
Z	-15.4
GSMY	7.6
Z	-13.9

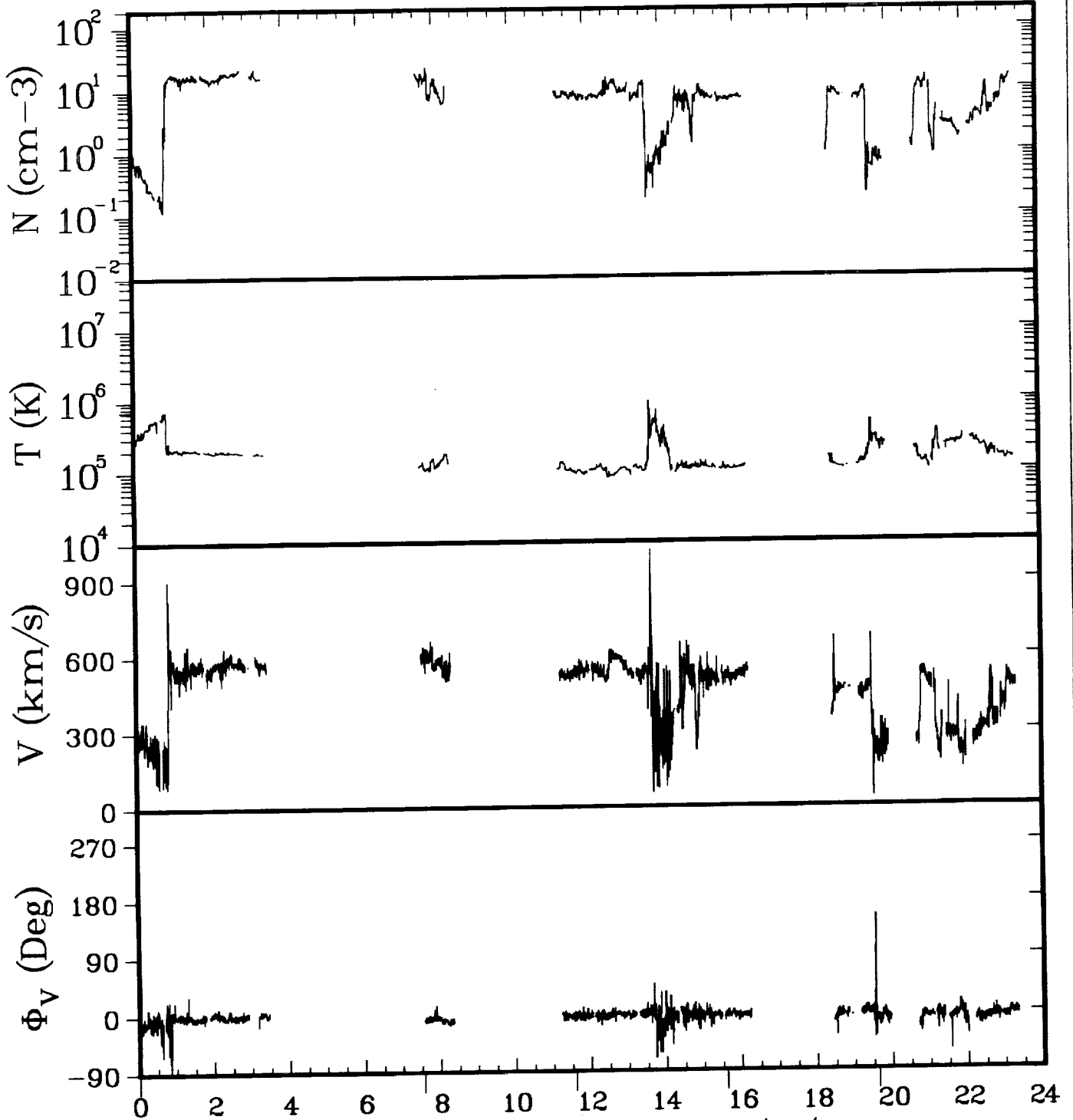

ISEE-3 ELECTRONS 05/17/83

GSEX	-187.4	-188.3	-188.7	-189.2	-189.7
Y	3.0	2.8	2.7	2.6	2.5
Z	-16.0	-16.3	-16.4	-16.5	-16.6
GSMY	9.6	4.3	3.1	5.5	8.8
Z	-13.2	-15.9	-16.3	-15.8	-14.3

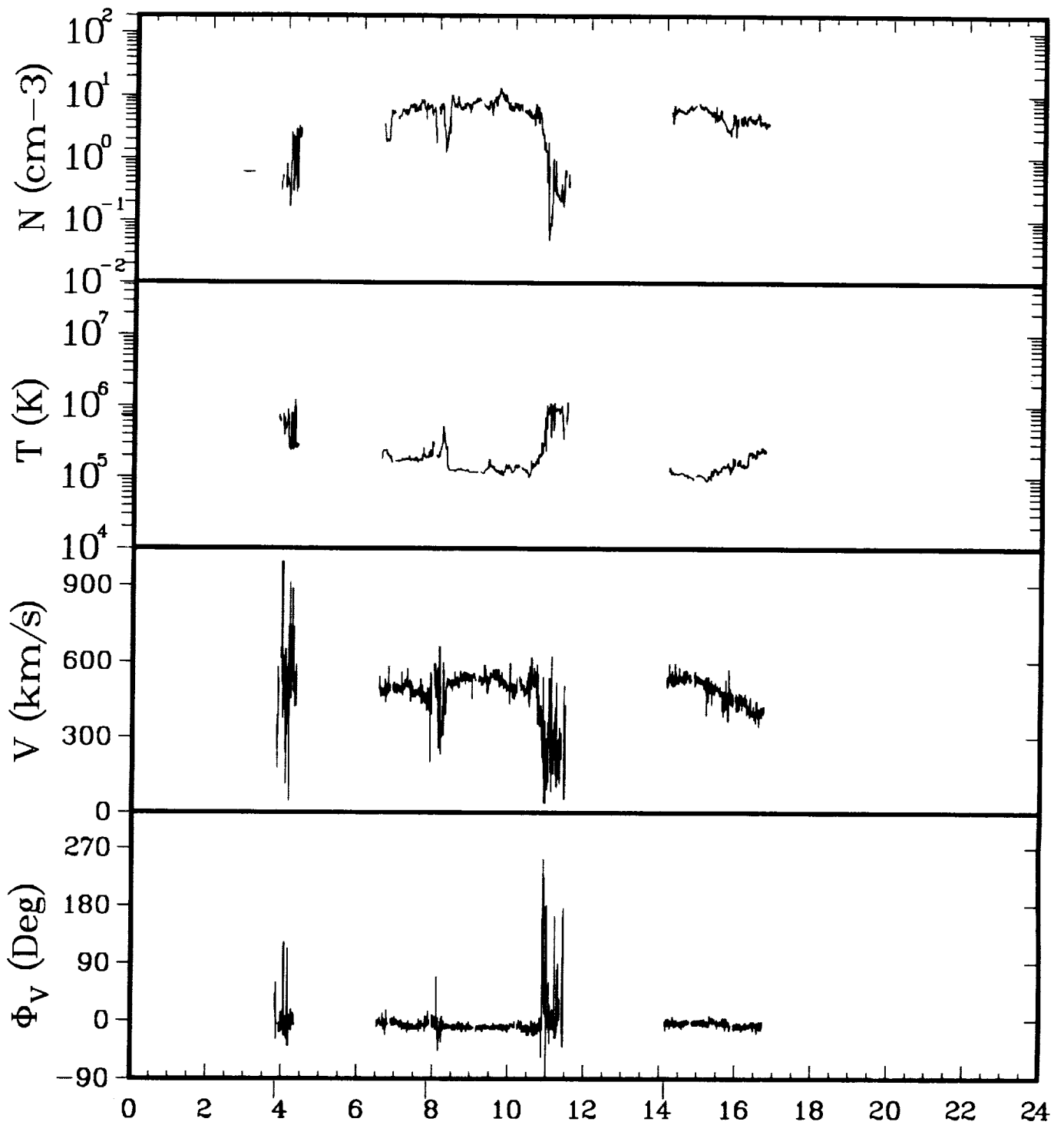

ISEE-3 ELECTRONS 05/18/83

GSEX	-190.6	-191.1	-191.8
Y	2.2	2.1	1.9
Z	-16.9	-17.0	-17.1
GSMY	6.7	3.3	3.5
Z	-15.6	-16.8	-16.9

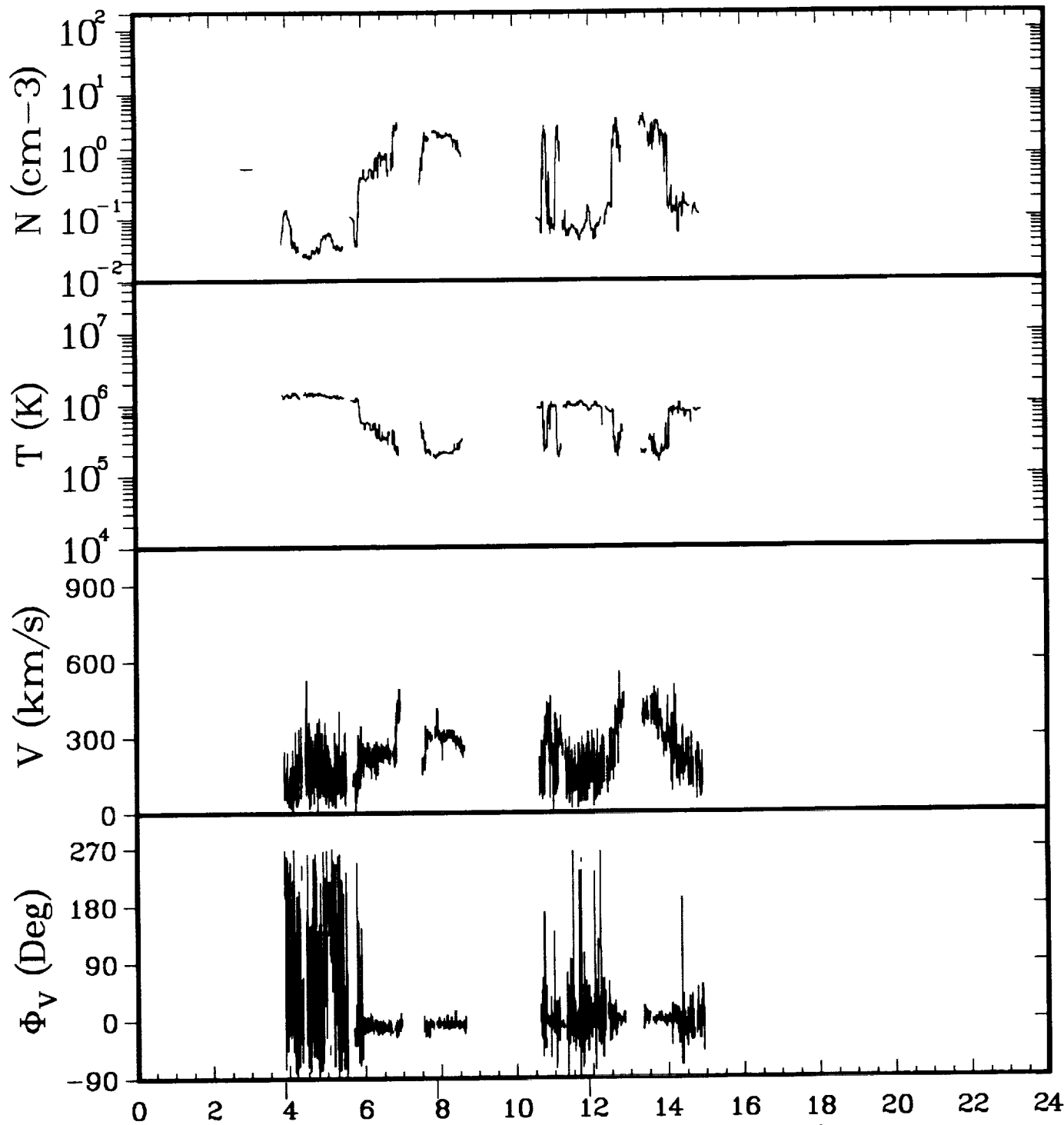

ISEE-3 ELECTRONS 05/19/83

GSEX	-193.3	-193.8	-194.2
Y	1.5	1.4	1.3
Z	-17.5	-17.6	-17.7
GSMY	6.1	2.6	1.6
Z	-16.5	-17.5	-17.7

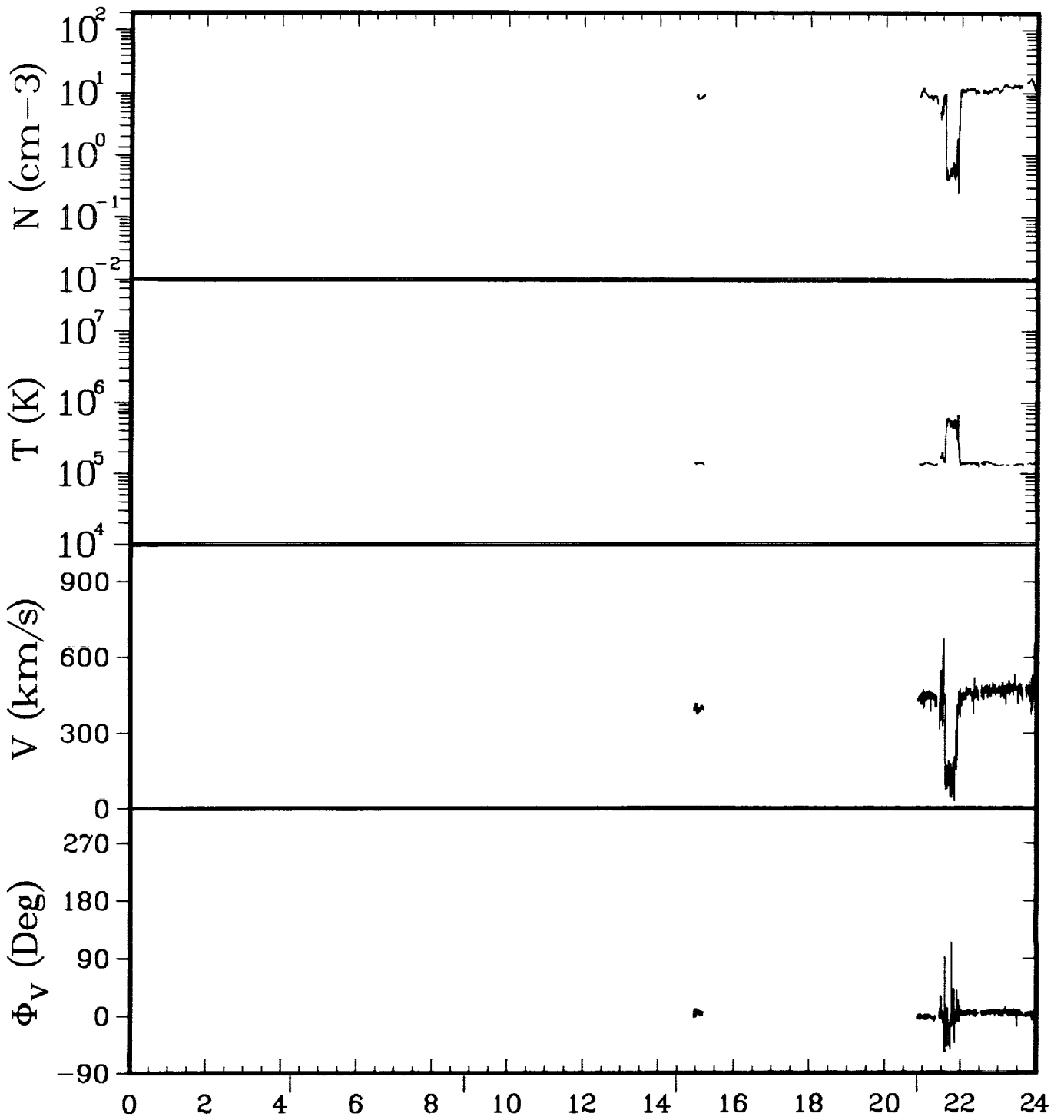

ISEE-3 ELECTRONS 05/20/83

GSEX	-196.0	-196.4	-197.0	-197.7
Y	0.9	0.8	0.7	0.5
Z	-18.2	-18.3	-18.4	-18.6
GSMY	5.1	1.3	2.5	8.1
Z	-17.4	-18.2	-18.3	-16.7

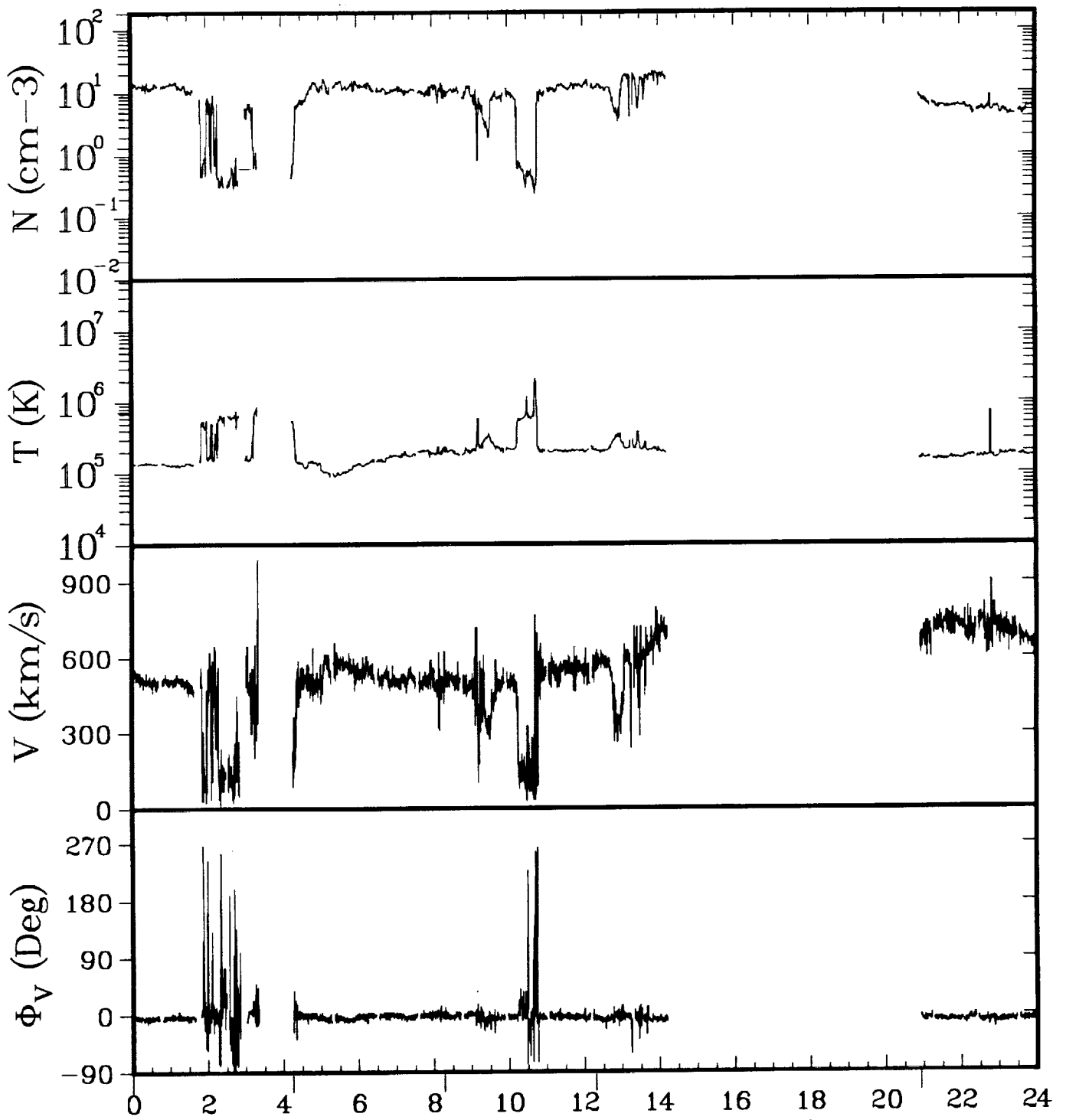

ISEE-3 ELECTRONS 05/21/83

GSEX	-198.0	-198.4	-198.8	-199.2	-200.1
Y	0.4	0.3	0.2	0.1	0.0
Z	-18.7	-18.8	-18.9	-19.0	-19.2
GSMY	7.9	4.6	1.0	0.3	7.7
Z	-16.9	-18.2	-18.8	-19.0	-17.5

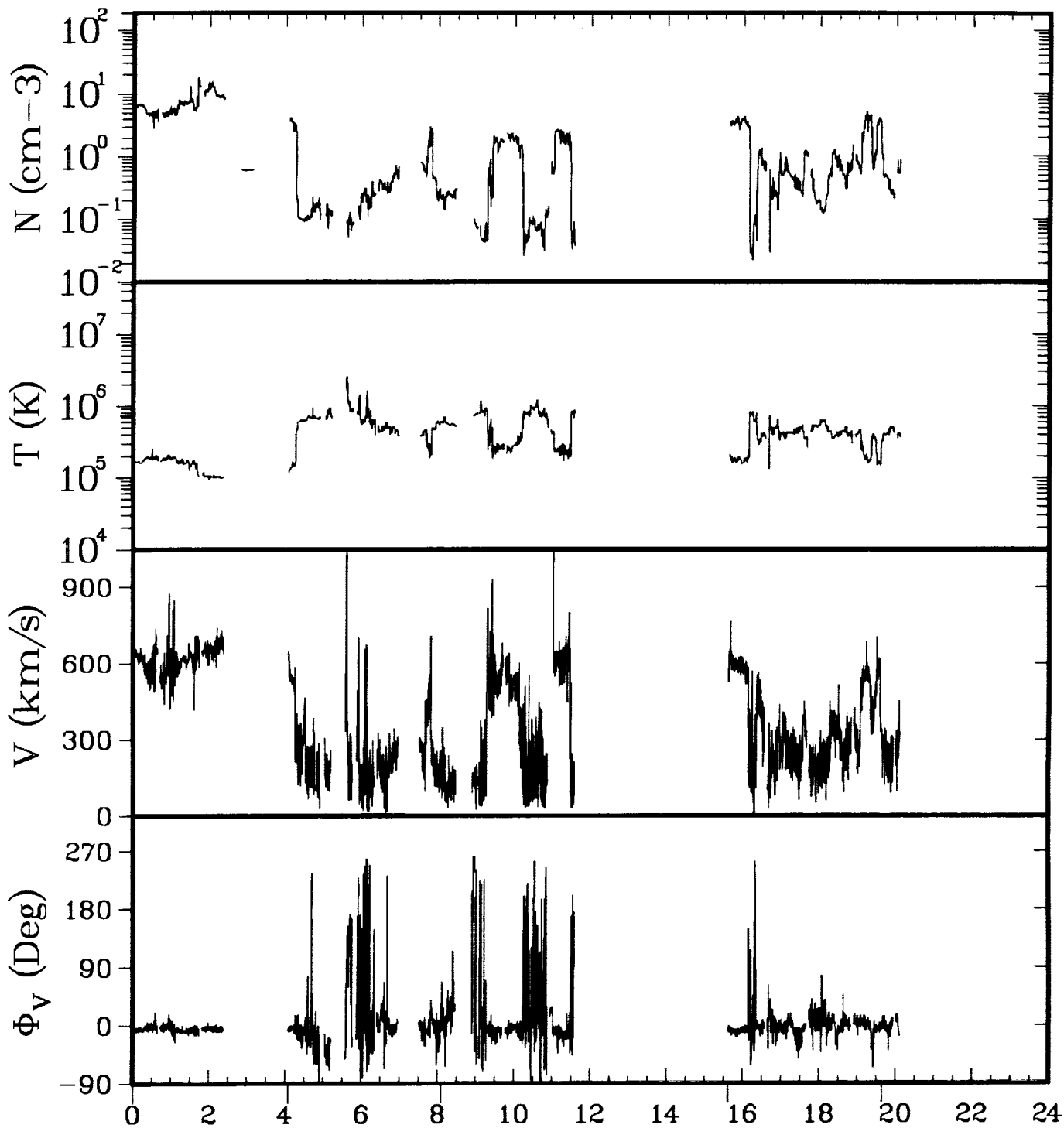

ISEE-3 ELECTRONS 05/22/83

GSEX	-200.4	-200.7	-201.1	-201.8	-202.2
Y	-0.1	-0.2	-0.3	-0.4	-0.5
Z	-19.2	-19.3	-19.4	-19.6	-19.7
GSMY	7.5	4.3	0.5	2.5	6.7
Z	-17.7	-18.9	-19.4	-19.5	-18.5

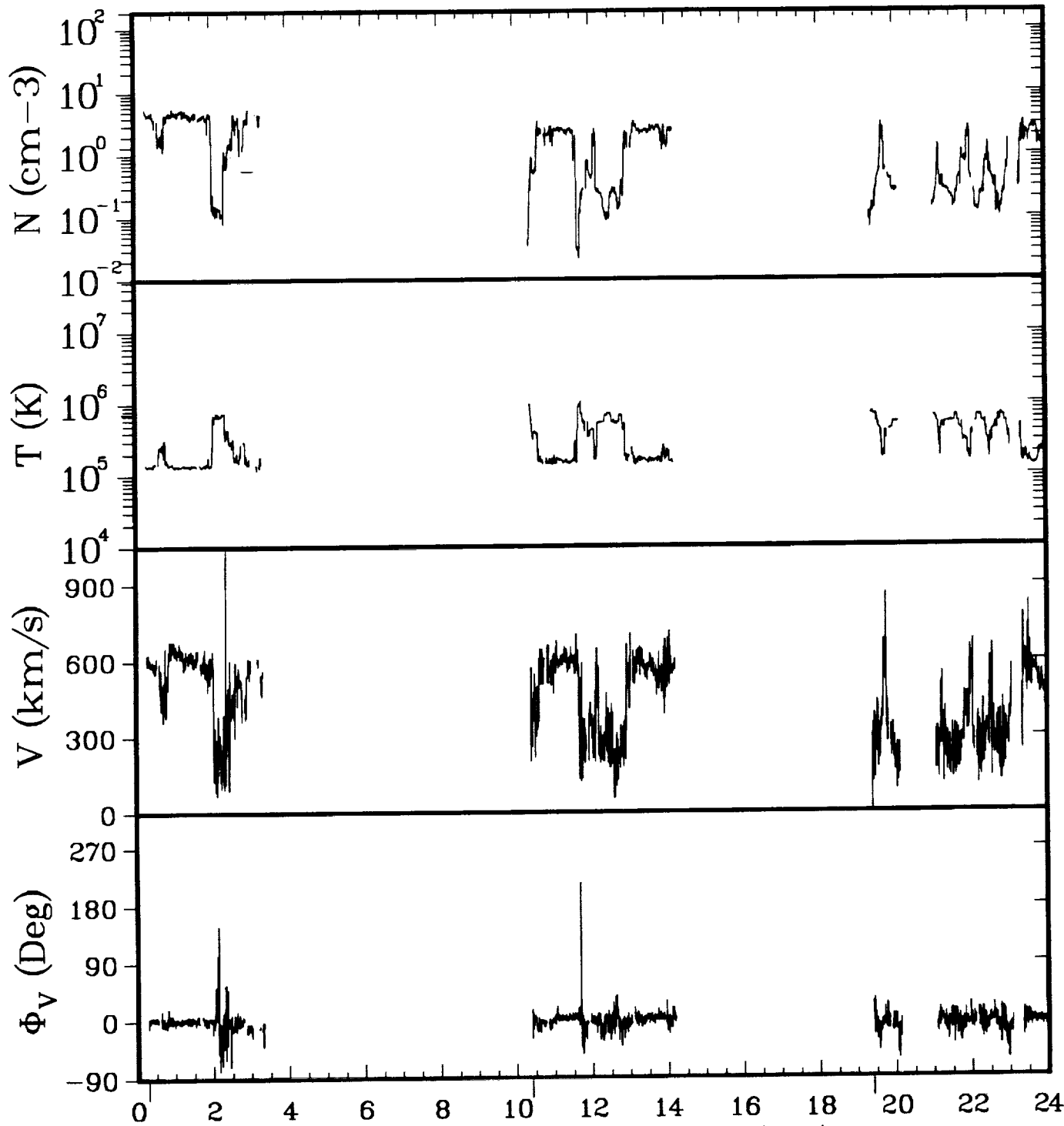

ISEE-3 ELECTRONS 05/23/83

GSEX	-202.6	-203.5	-204.3
Y	-0.6	-0.8	-1.0
Z	-19.8	-20.0	-20.2
GSMY	7.1	-1.1	6.2
Z	-18.5	-20.0	-19.3

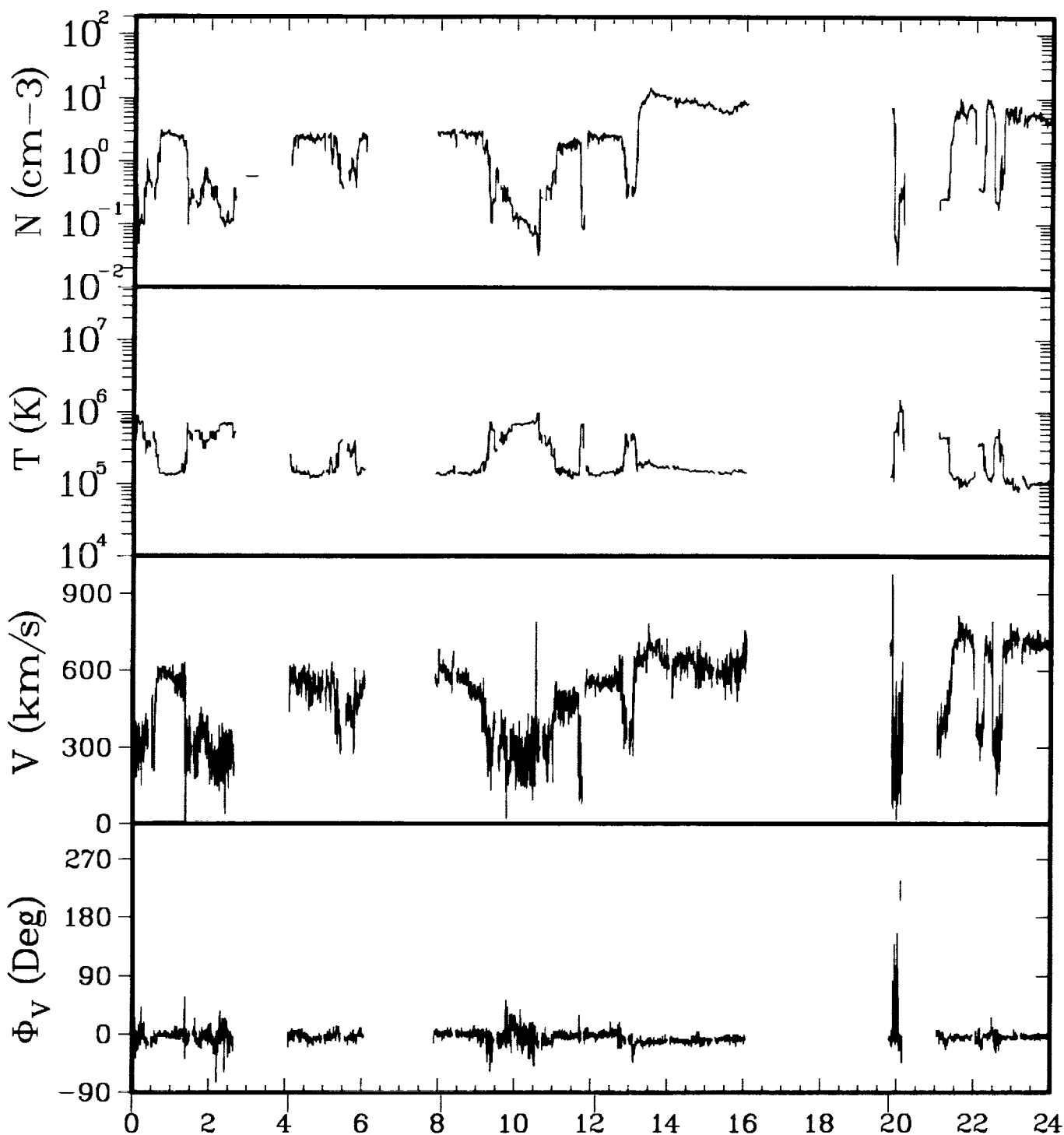

ISEE-3 ELECTRONS 05/24/83

GSEX	-204.7	-205.1	-205.4	-205.7	-206.4
Y	-1.1	-1.1	-1.2	-1.3	-1.4
Z	-20.3	-20.4	-20.5	-20.6	-20.7
GSMY	6.9	3.4	-0.7	-1.5	6.2
Z	-19.1	-20.1	-20.5	-20.5	-19.8

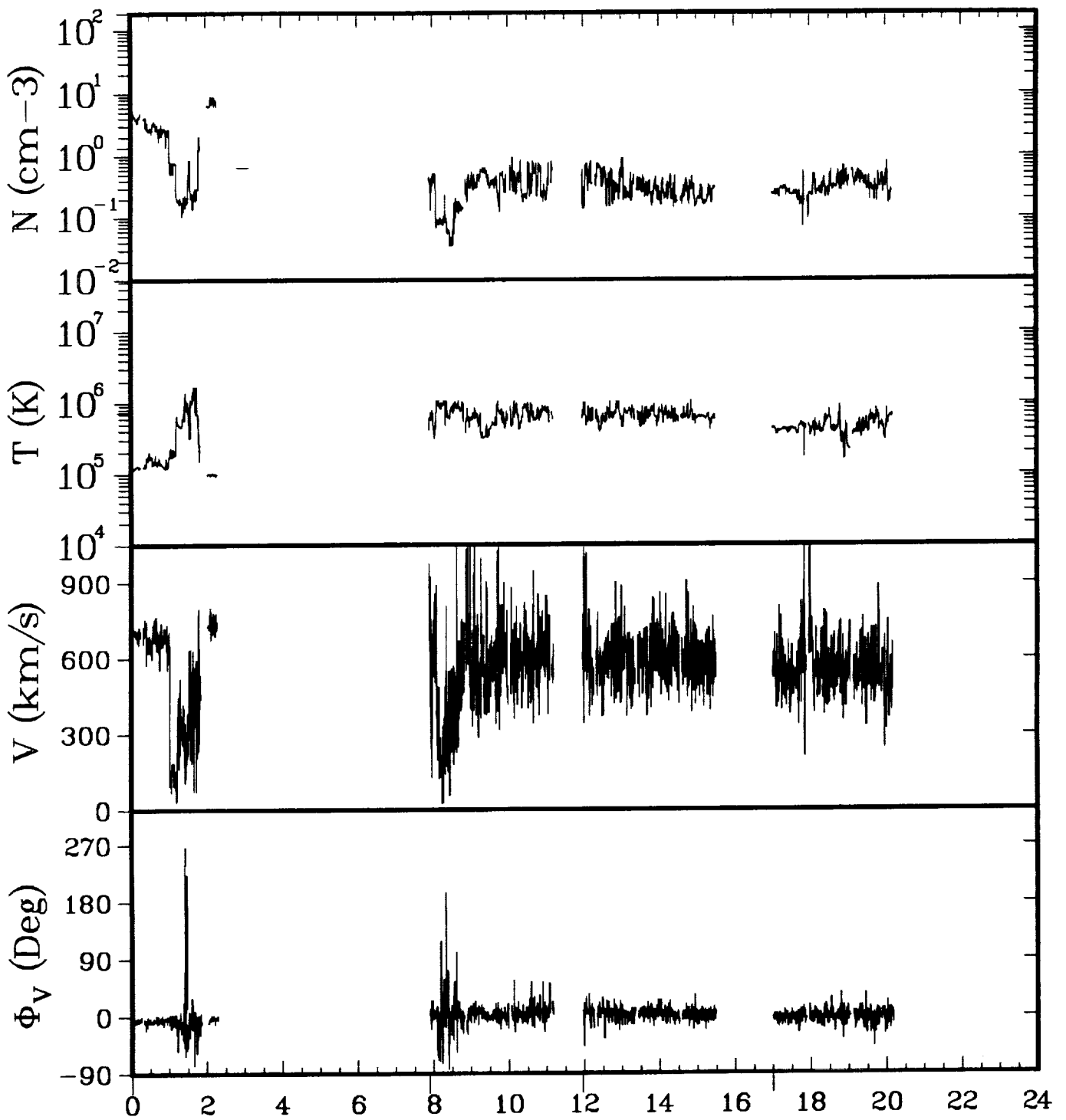

ISEE-3 ELECTRONS 05/25/83

GSEX	-206.7	-207.3	-207.7	-208.1
Y	-1.5	-1.6	-1.7	-1.7
Z	-20.8	-21.0	-21.0	-21.1
GSMY	6.6	-1.0	-2.1	2.8
Z	-19.8	-21.0	-21.0	-21.0

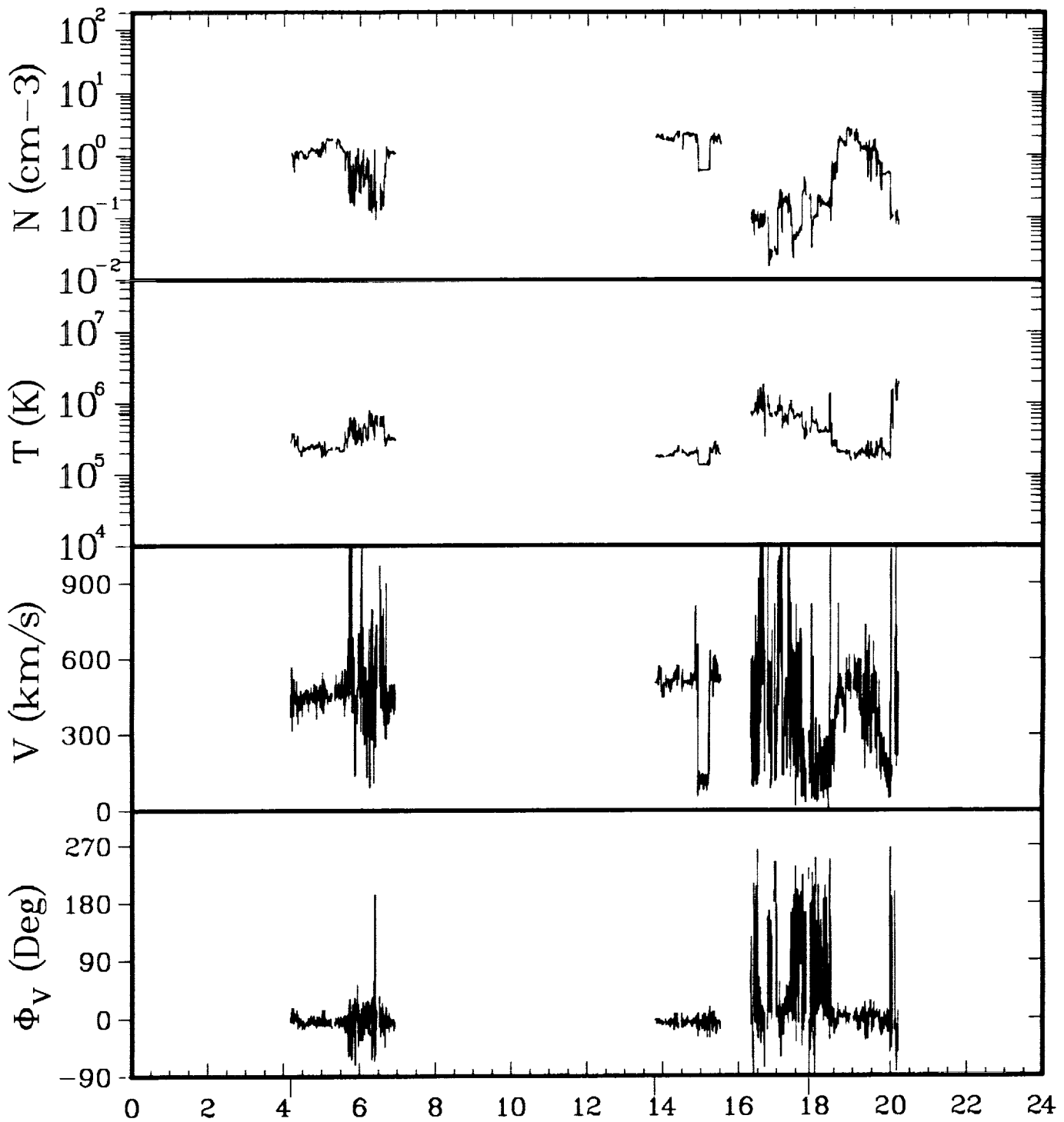

ISEE-3 ELECTRONS 05/26/83

GSEX	-208.9	-209.6	-209.9
Y	-1.9	-2.0	-2.1
Z	-21.3	-21.5	-21.6
GSMY	2.5	-1.5	3.6
Z	-21.3	-21.6	-21.4

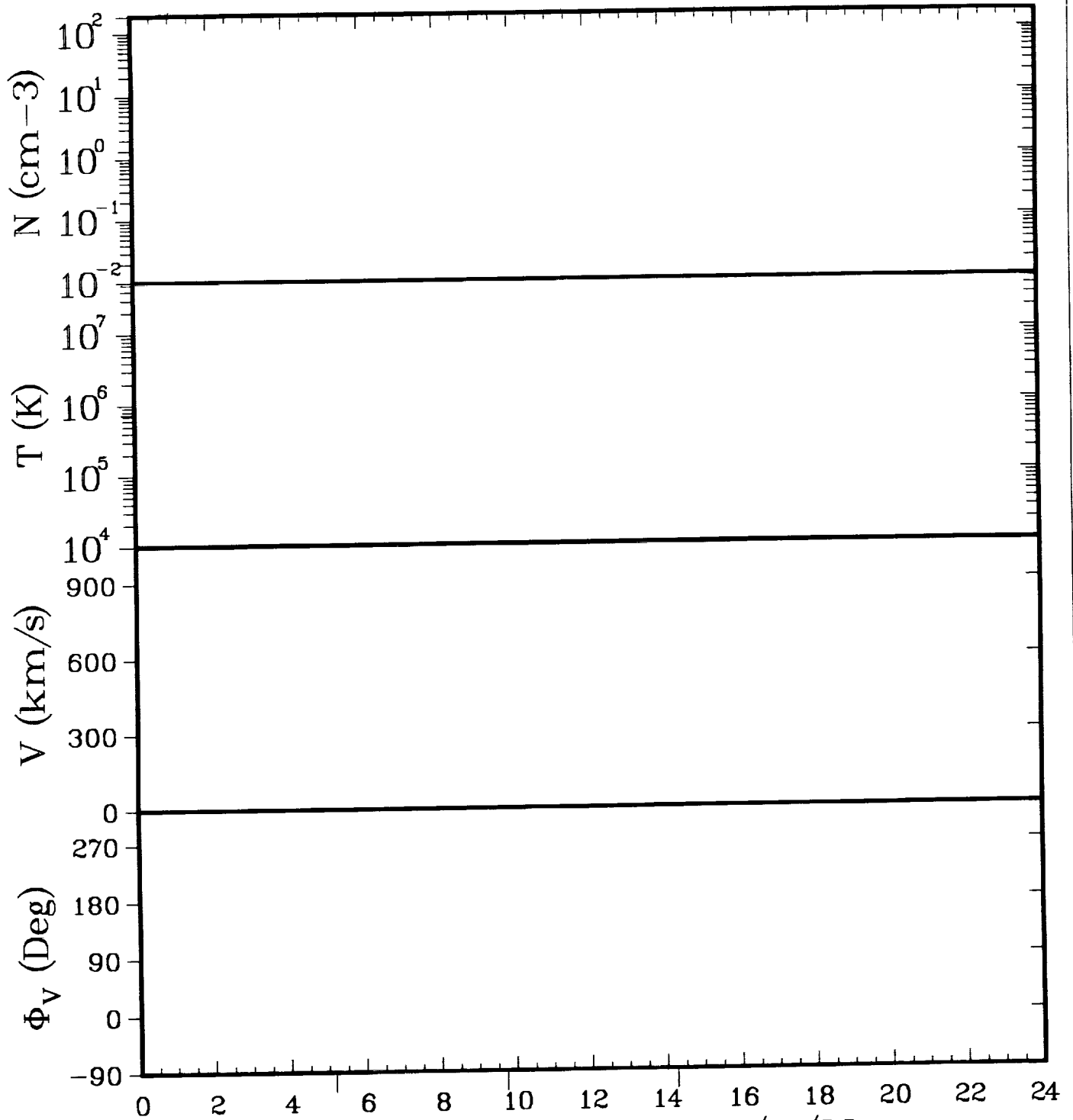

ISEE-3 ELECTRONS 05/27/83

GSEX	-210.7	-211.0	-211.4
Y	-2.2	-2.2	-2.3
Z	-21.8	-21.9	-21.9
GSMY	1.0	-3.0	-1.4
Z	-21.9	-21.8	-22.0

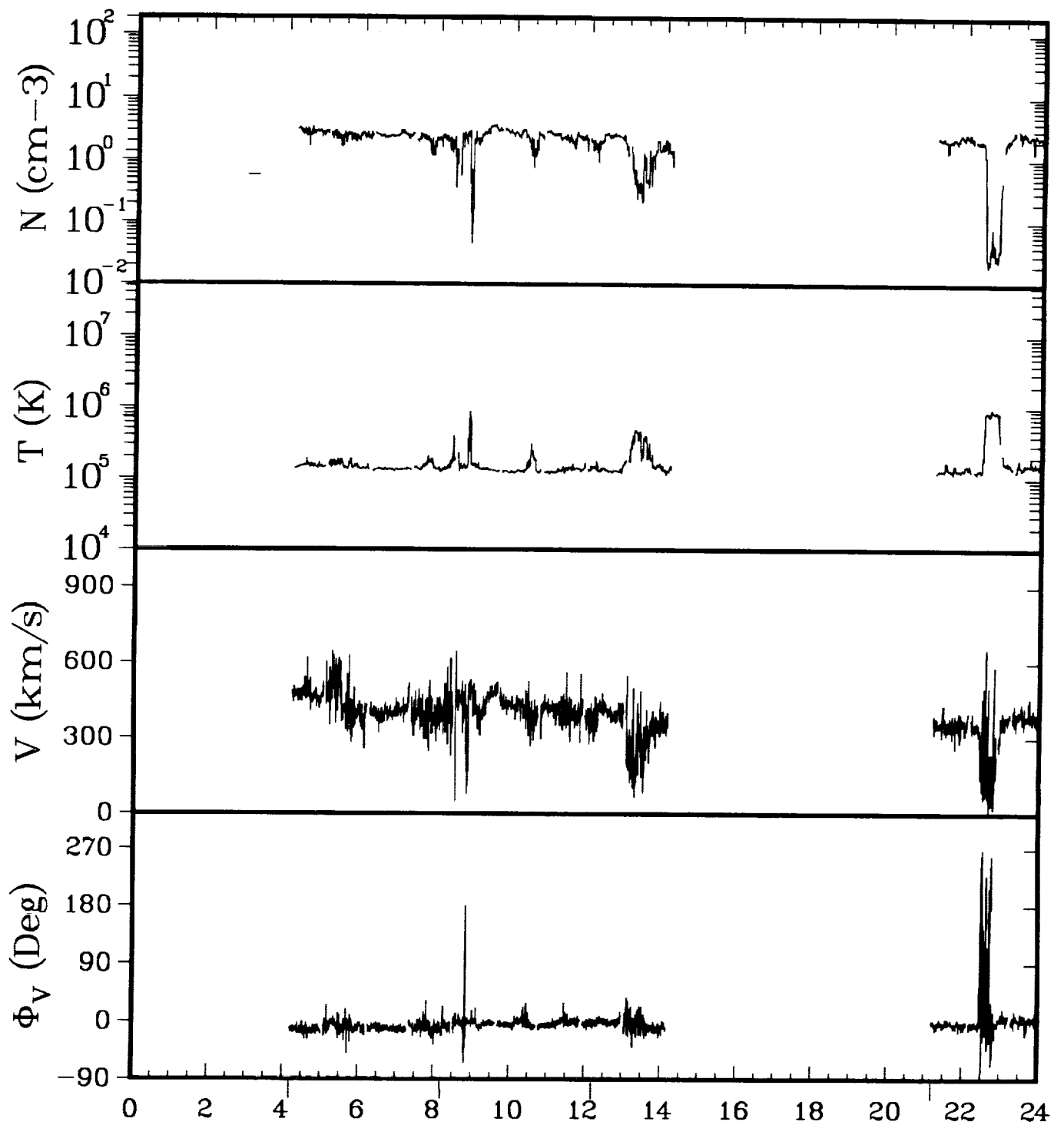

ISEE-3 ELECTRONS 05/28/83

GSEX	-212.3	-212.6	-212.8	-213.4
Y	-2.4	-2.5	-2.5	-2.5
Z	-22.2	-22.2	-22.3	-22.4
GSMY	1.9	-2.5	-3.3	6.0
Z	-22.2	-22.2	-22.2	-21.7

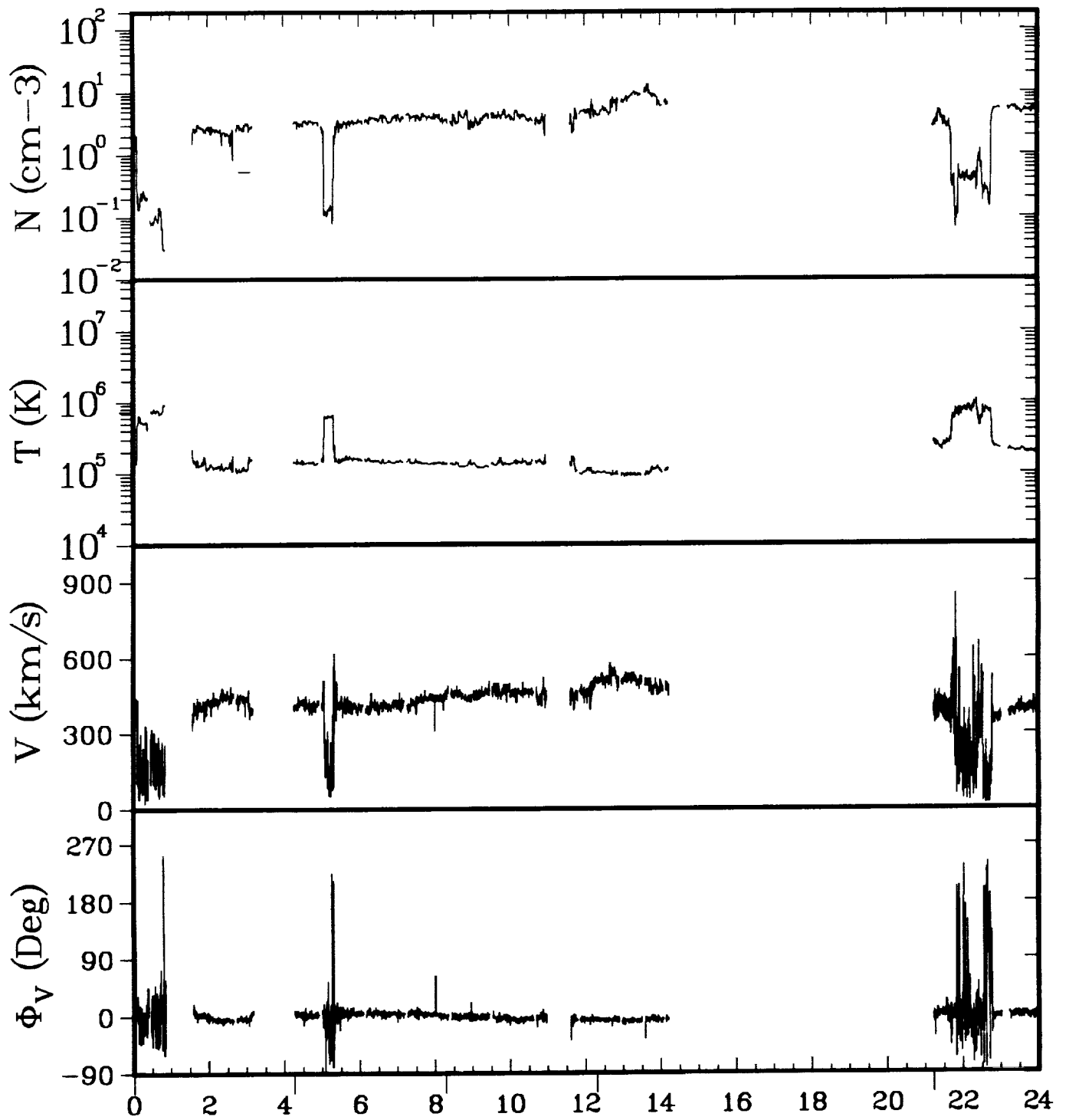

ISEE-3 ELECTRONS 05/29/83

GSEX	-213.6	-213.8	-214.1	-214.3	-214.8
Y	-2.6	-2.6	-2.6	-2.6	-2.7
Z	-22.5	-22.5	-22.6	-22.6	-22.7
GSMY	5.7	1.5	-2.9	-3.6	5.9
Z	-21.9	-22.6	-22.5	-22.5	-22.1

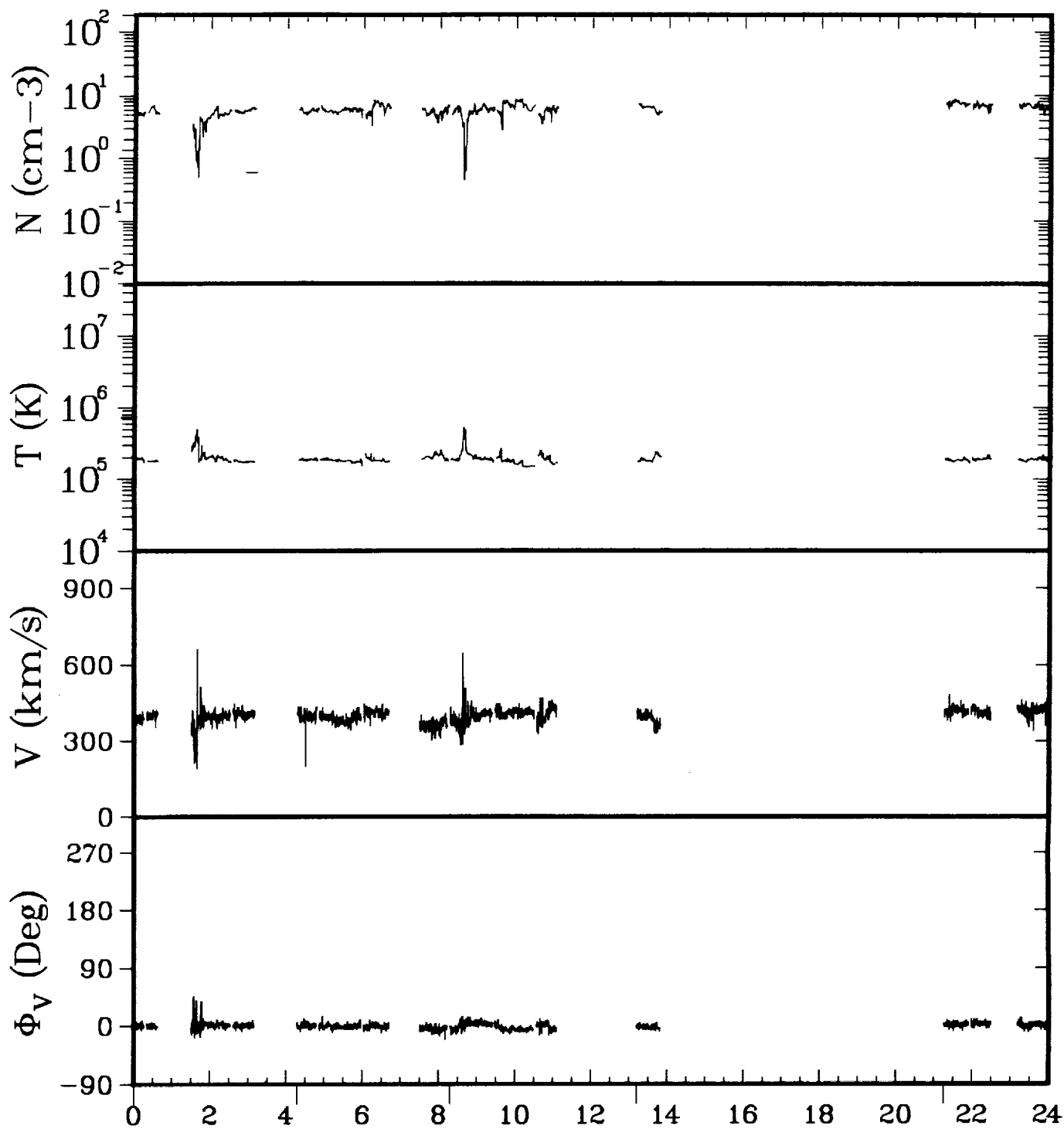

ISEE-3 ELECTRONS 05/30/83

GSEX	-215.0	-215.2	-215.5	-215.7	-216.2
Y	-2.7	-2.7	-2.7	-2.7	-2.7
Z	-22.8	-22.8	-22.9	-22.9	-23.0
GSMY	5.5	1.3	-3.1	-3.2	5.8
Z	-22.3	-23.0	-22.8	-22.9	-22.5

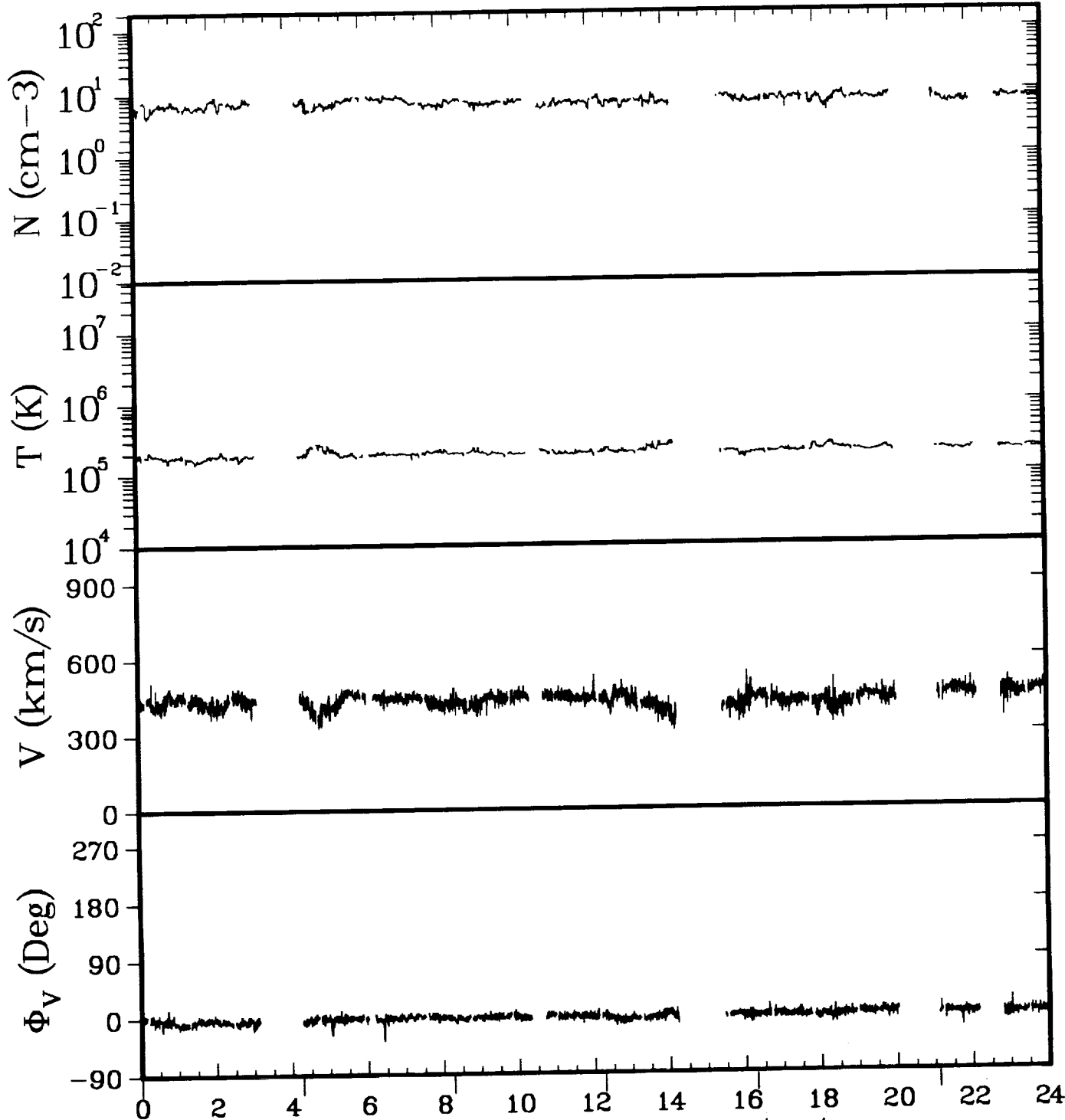

ISEE-3 ELECTRONS 05/31/83

GSEX	-216.3	-216.6	-216.8	-217.0	-217.2	-217.5
Y	-2.7	-2.7	-2.7	-2.7	-2.7	-2.7
Z	-23.1	-23.1	-23.2	-23.2	-23.3	-23.3
GSMY	5.5	1.2	-3.3	-4.0	0.4	5.7
Z	-22.6	-23.3	-23.1	-23.0	-23.4	-22.8

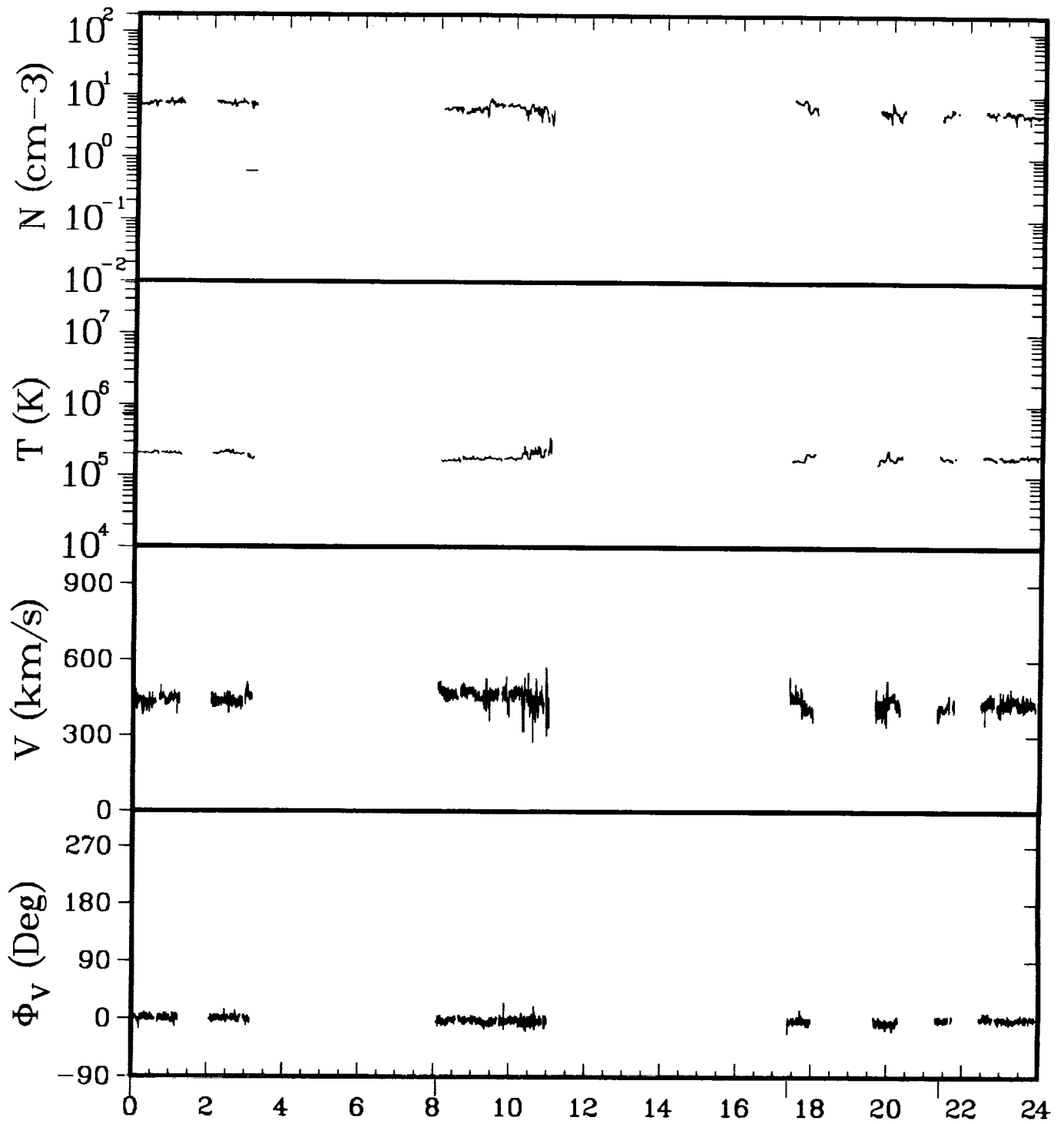

ISEE-3 ELECTRONS 06/01/83

GSEX	-217.6	-218.0	-218.5	-218.6
Y	-2.7	-2.7	-2.7	-2.7
Z	-23.3	-23.4	-23.5	-23.5
GSMY	5.4	-3.2	1.9	5.7
Z	-22.9	-23.3	-23.5	-22.9

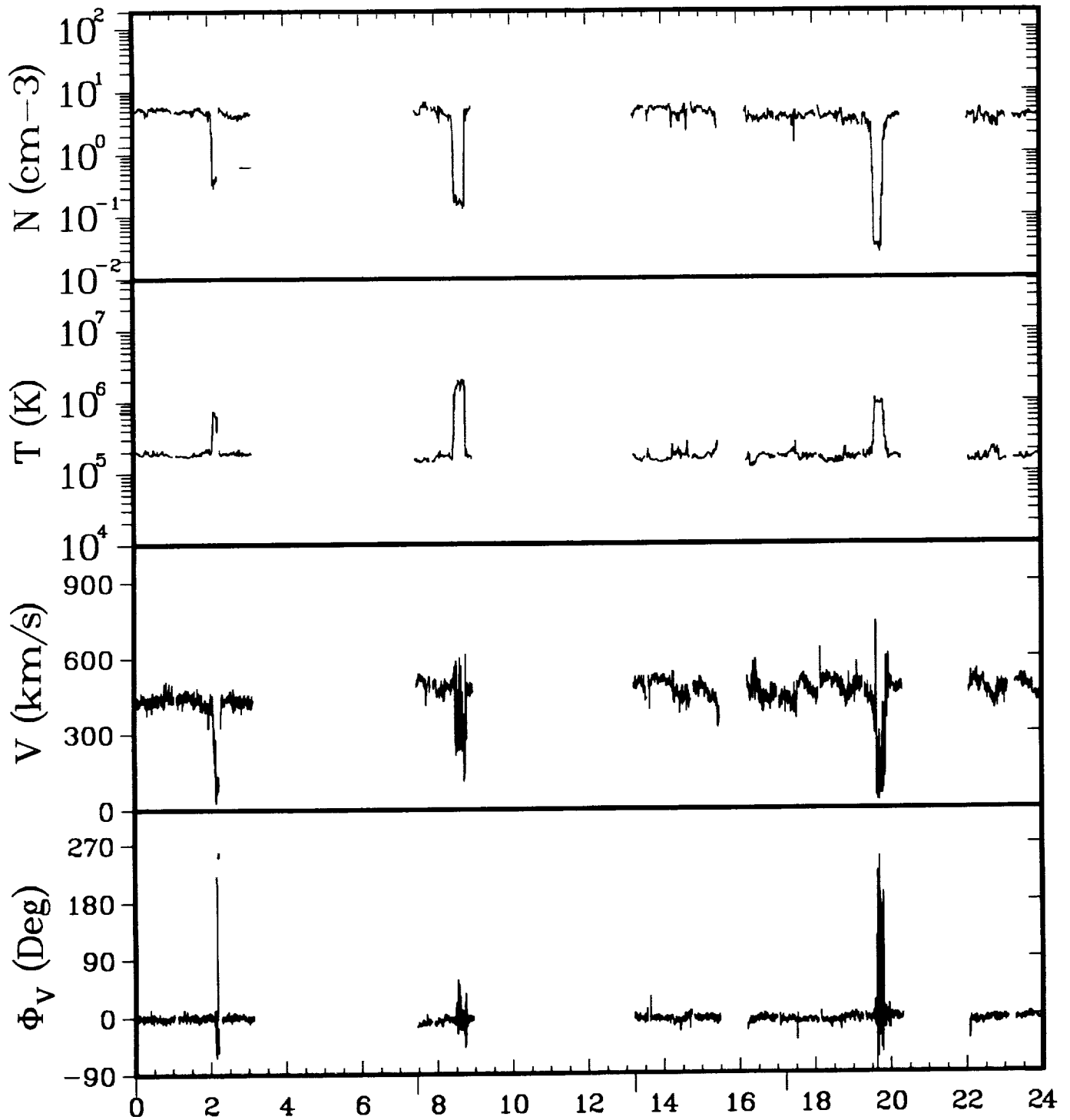

ISEE-3 ELECTRONS 06/02/83

GSEX	-218.7	-219.1	-219.3	-219.5
Y	-2.7	-2.7	-2.7	-2.7
Z	-23.5	-23.5	-23.5	-23.6
GSMY	5.3	-2.8	-3.8	1.5
Z	-23.0	-23.5	-23.4	-23.7

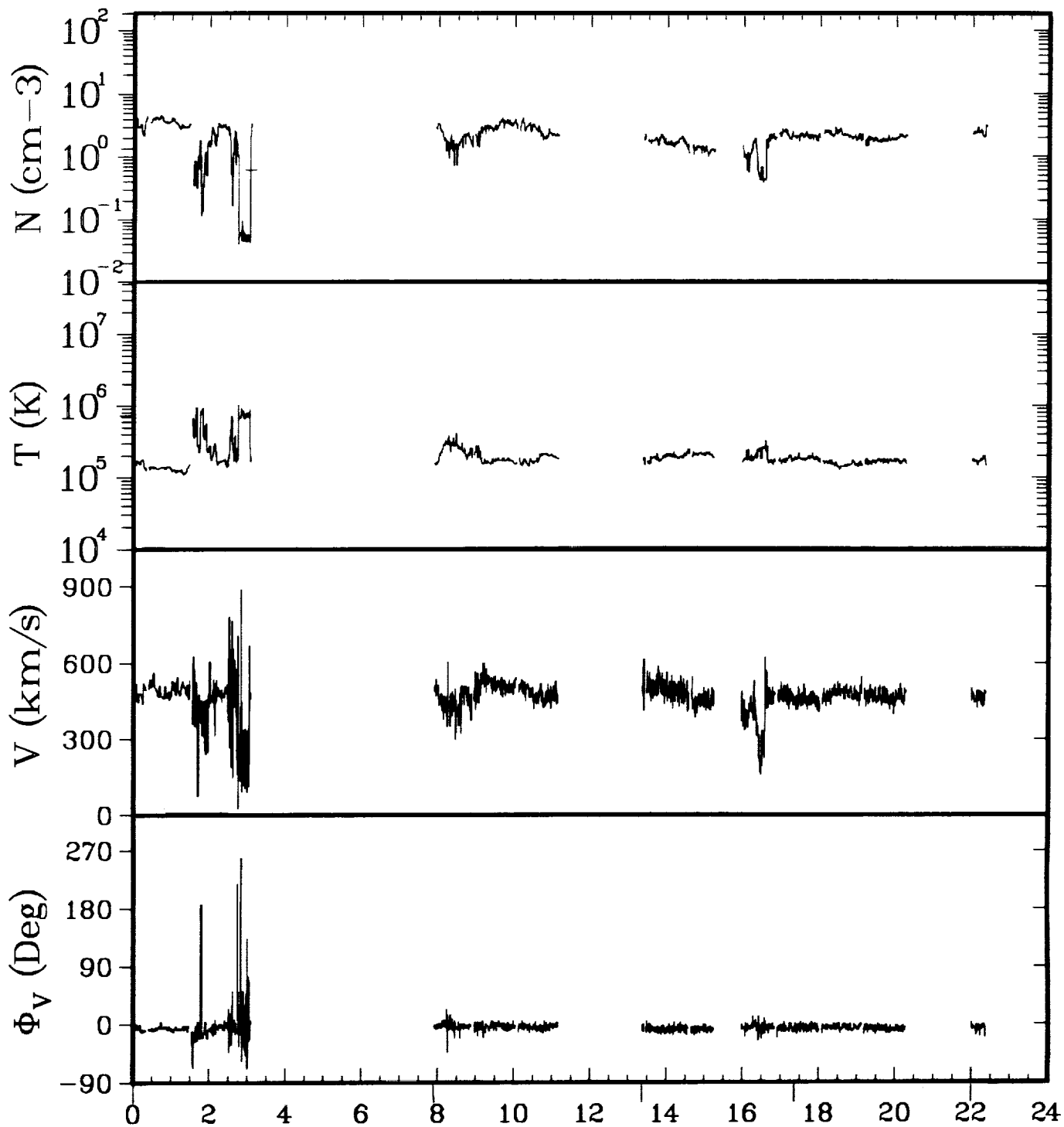

ISEE-3 ELECTRONS 06/03/83

GSEX	-219.8	-220.1	-220.3	-220.5	-220.7
Y	-2.7	-2.7	-2.7	-2.7	-2.7
Z	-23.6	-23.6	-23.6	-23.6	-23.6
GSMY	5.1	-3.5	-3.8	1.5	5.5
Z	-23.2	-23.5	-23.4	-23.7	-23.1

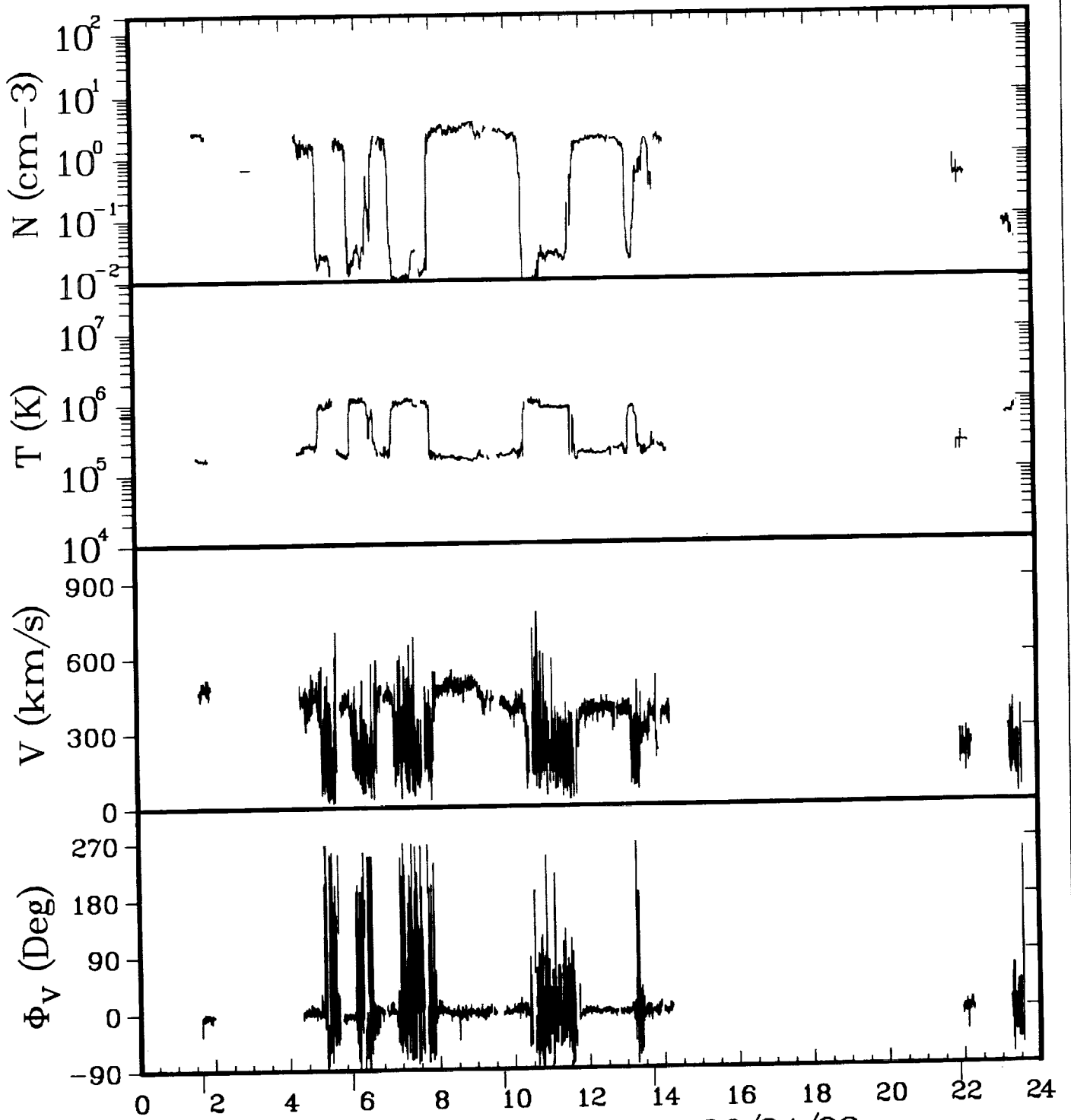

ISEE-3 ELECTRONS 06/04/83

GSEX	-220.8	-221.0	-221.1	-221.3	-221.6
Y	-2.7	-2.7	-2.7	-2.7	-2.7
Z	-23.6	-23.6	-23.6	-23.6	-23.6
GSMY	3.7	-1.1	-4.8	-3.6	5.4
Z	-23.5	-23.7	-23.3	-23.5	-23.1

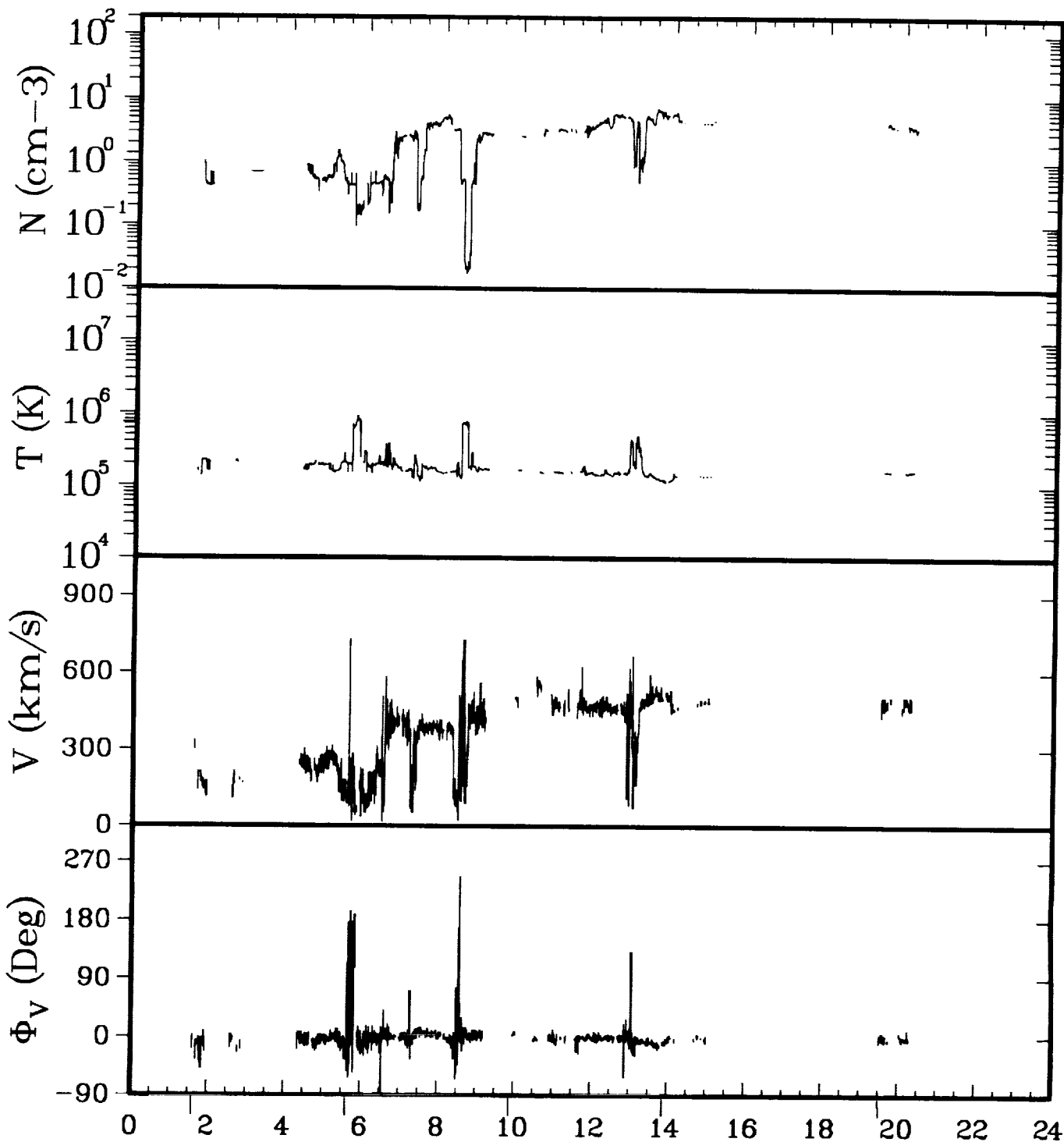

ISEE-3 ELECTRONS 06/05/83

GSEX	-221.8	-221.9	-222.1	-222.2	-222.4
Y	-2.6	-2.6	-2.6	-2.6	-2.5
Z	-23.6	-23.6	-23.6	-23.6	-23.6
GSMY	3.7	-1.1	-4.9	-3.5	4.1
Z	-23.5	-23.7	-23.2	-23.5	-23.4

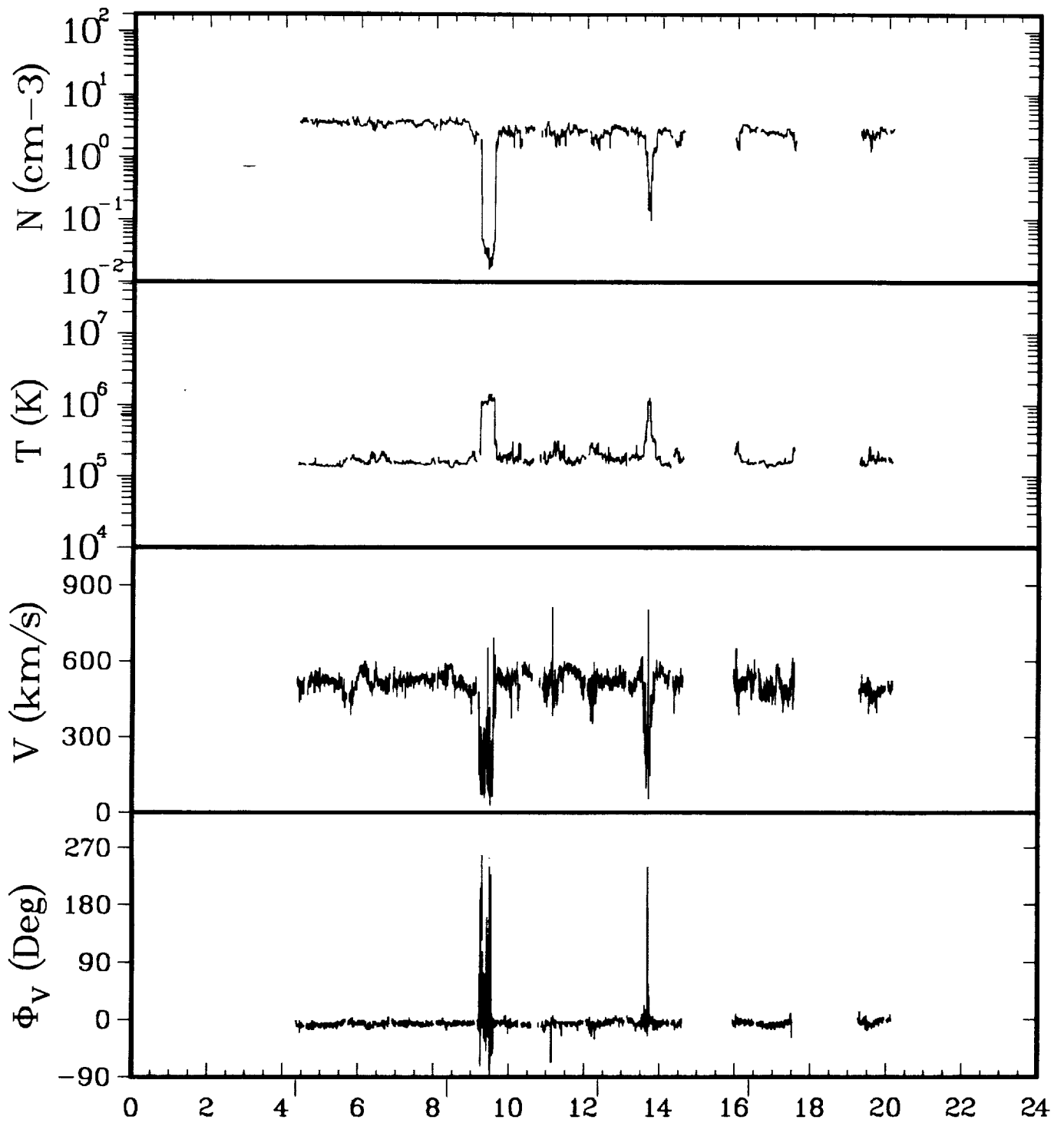

ISEE-3 ELECTRONS 06/06/83

GSEX	-222.7	-222.9	-223.0	-223.2
Y	-2.5	-2.4	-2.4	-2.4
Z	-23.6	-23.5	-23.5	-23.5
GSMY	0.4	-4.0	-4.7	-0.1
Z	-23.7	-23.3	-23.2	-23.6

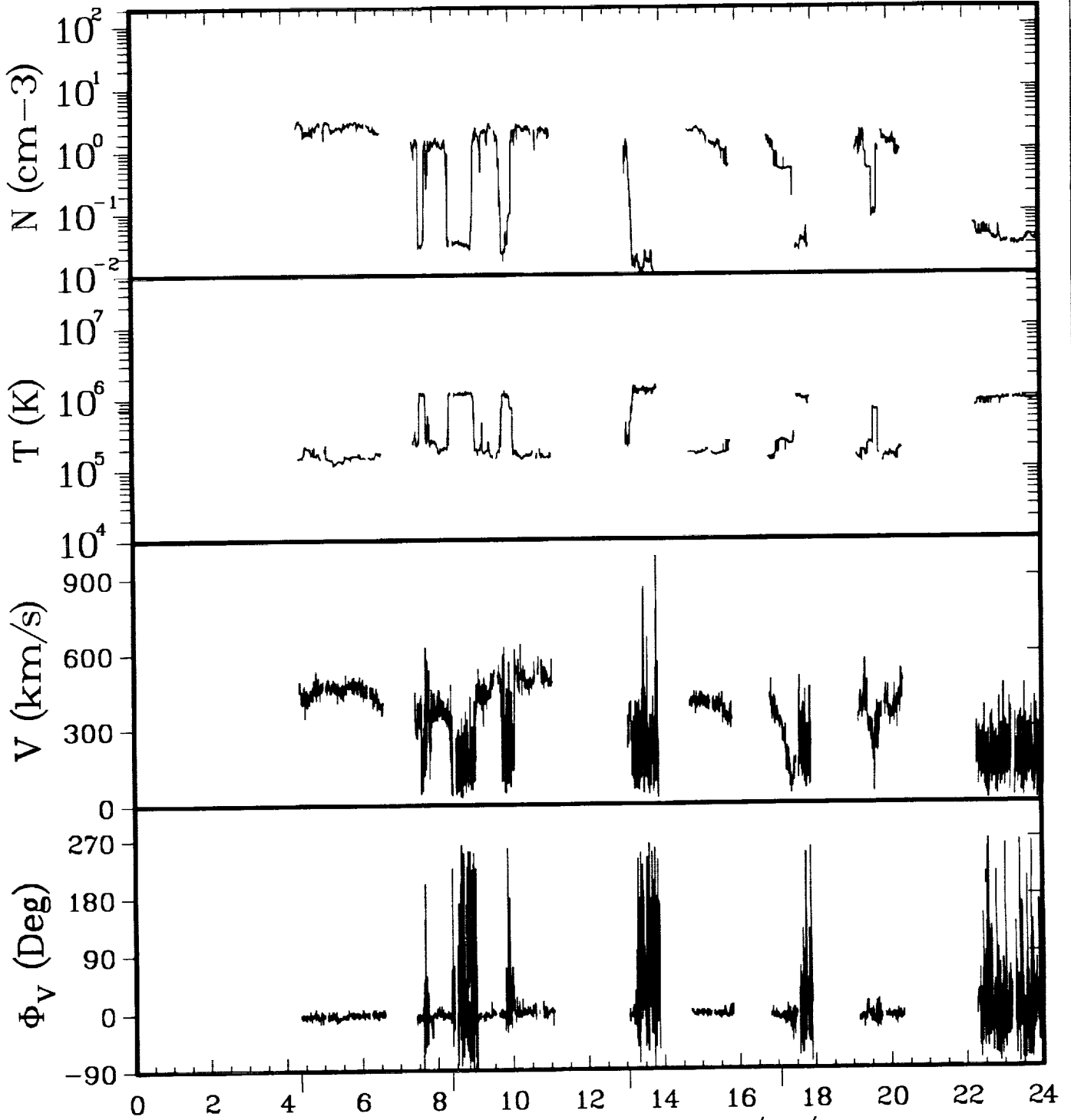

ISEE-3 ELECTRONS 06/07/83

GSEX	-223.6	-223.7	-223.9	-224.0
Y	-2.3	-2.2	-2.2	-2.1
Z	-23.5	-23.5	-23.4	-23.4
GSMY	0.5	-4.0	-4.1	1.0
Z	-23.6	-23.2	-23.2	-23.5

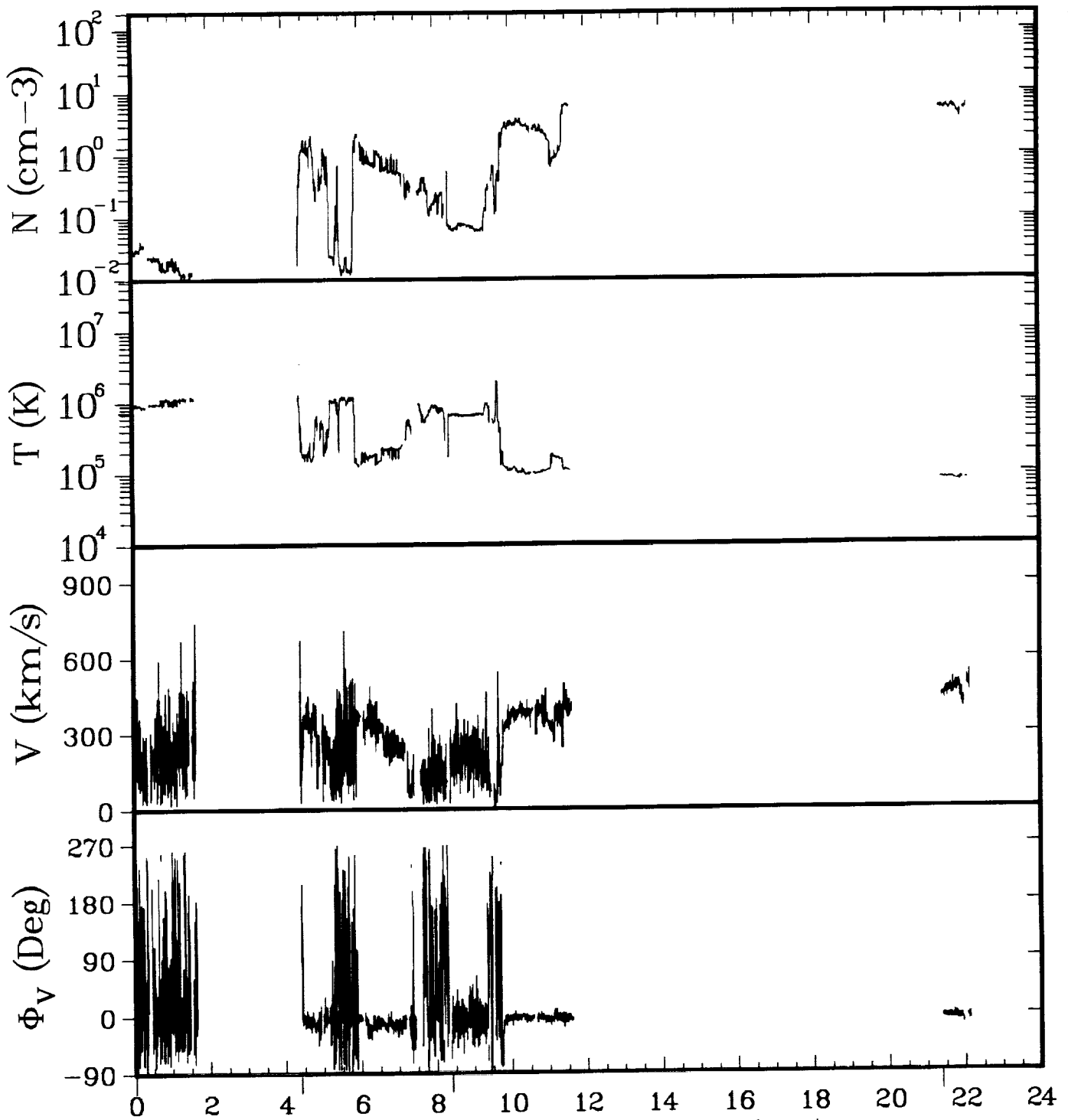

ISEE-3 ELECTRONS 06/08/83

GSEX	-224.3	-224.4	-224.5	-225.0
Y	-2.0	-2.0	-1.9	-1.7
Z	-23.4	-23.4	-23.3	-23.3
GSMY	5.0	0.6	-3.8	5.5
Z	-22.9	-23.4	-23.1	-22.7

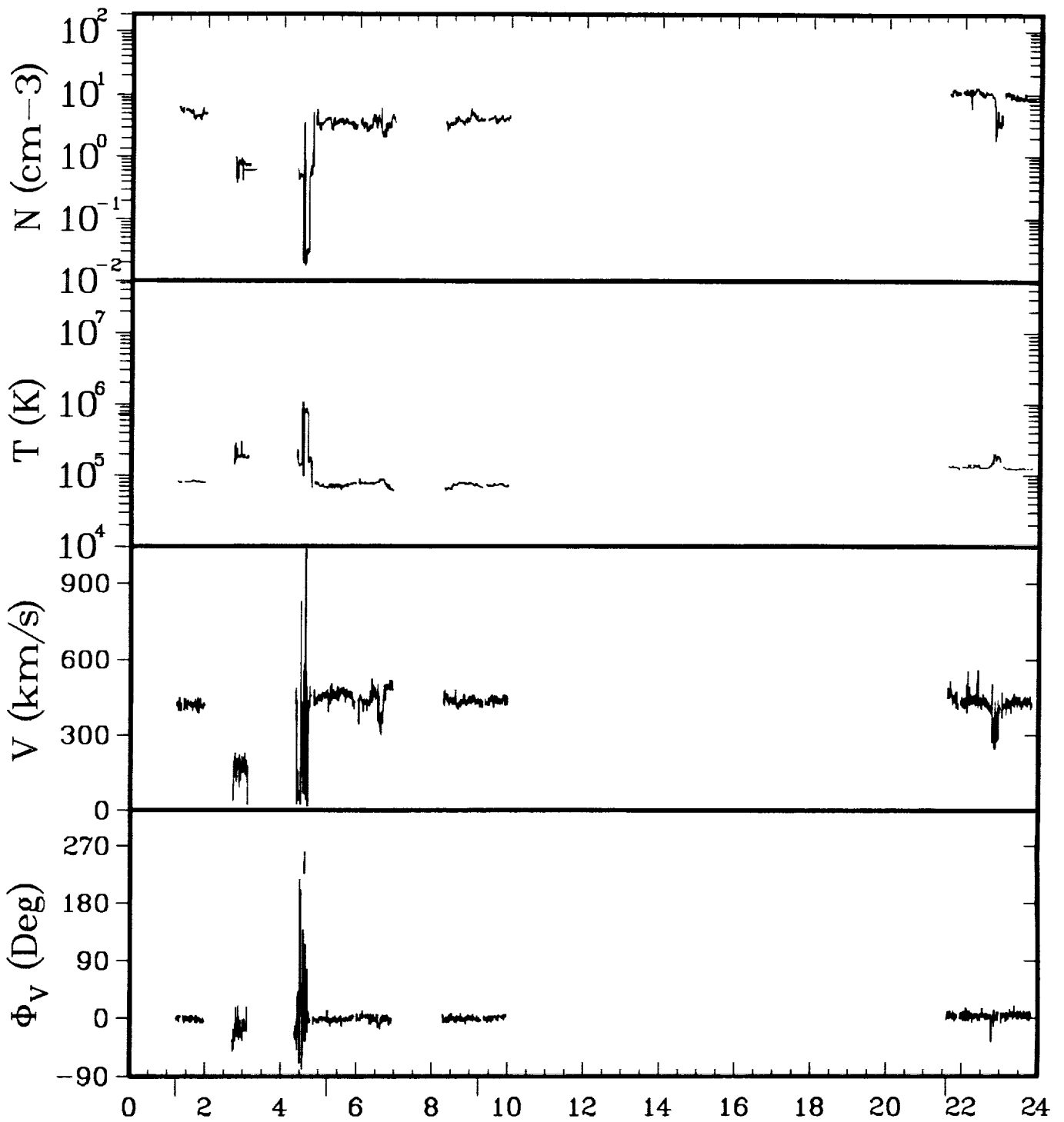

ISEE-3 ELECTRONS 06/09/83

GSEX	-225.1	-225.2	-225.4	-225.8
Y	-1.7	-1.6	-1.6	-1.4
Z	-23.2	-23.2	-23.2	-23.1
GSMY	4.3	-0.3	-4.2	5.7
Z	-22.9	-23.3	-22.9	-22.4

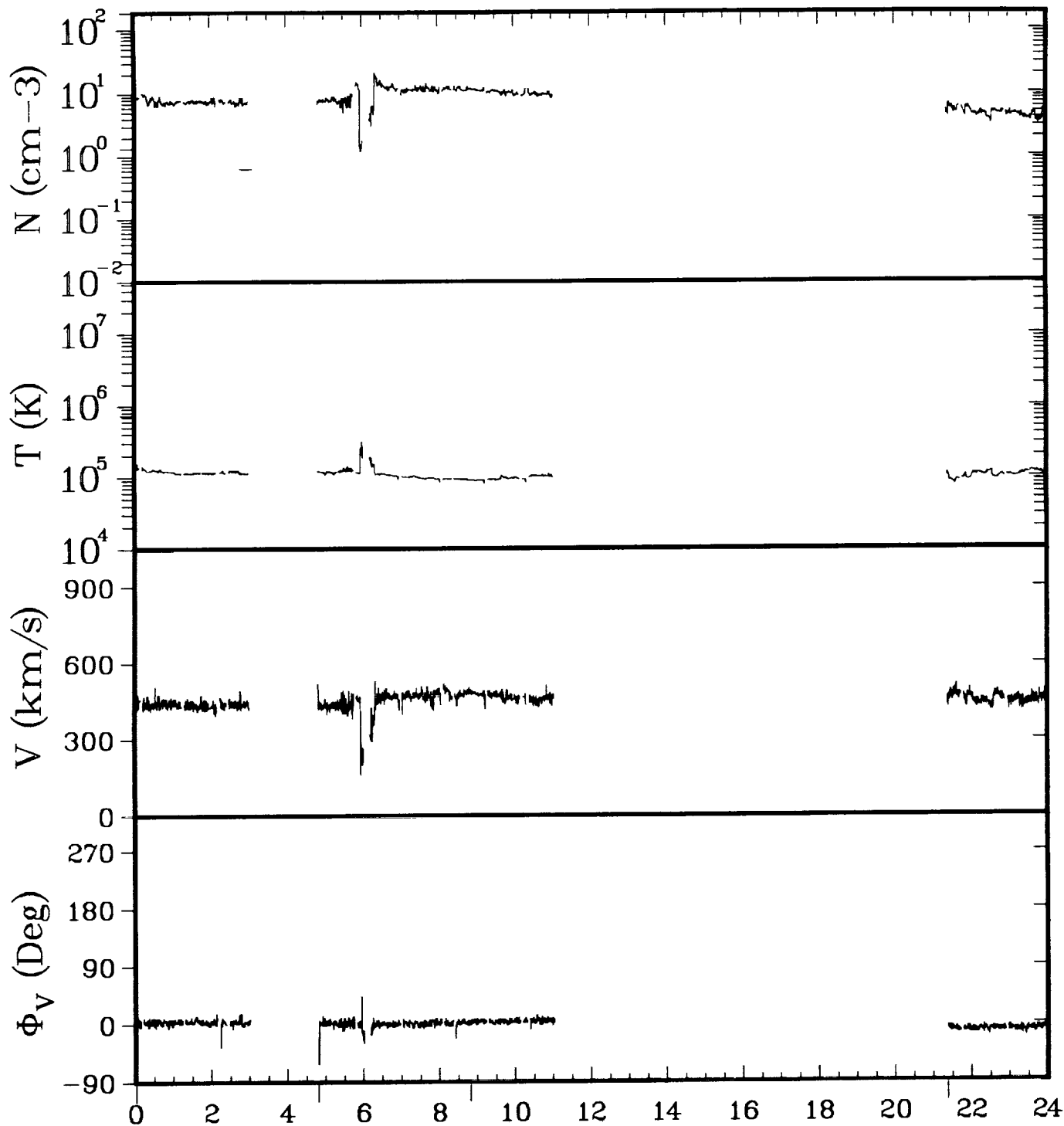

ISEE-3 ELECTRONS 06/10/83

GSEX	-225.8	-226.0	-226.1	-226.5
Y	-1.3	-1.3	-1.2	-1.0
Z	-23.1	-23.0	-23.0	-22.9
GSMY	5.3	0.4	-3.7	5.8
Z	-22.5	-23.1	-22.7	-22.2

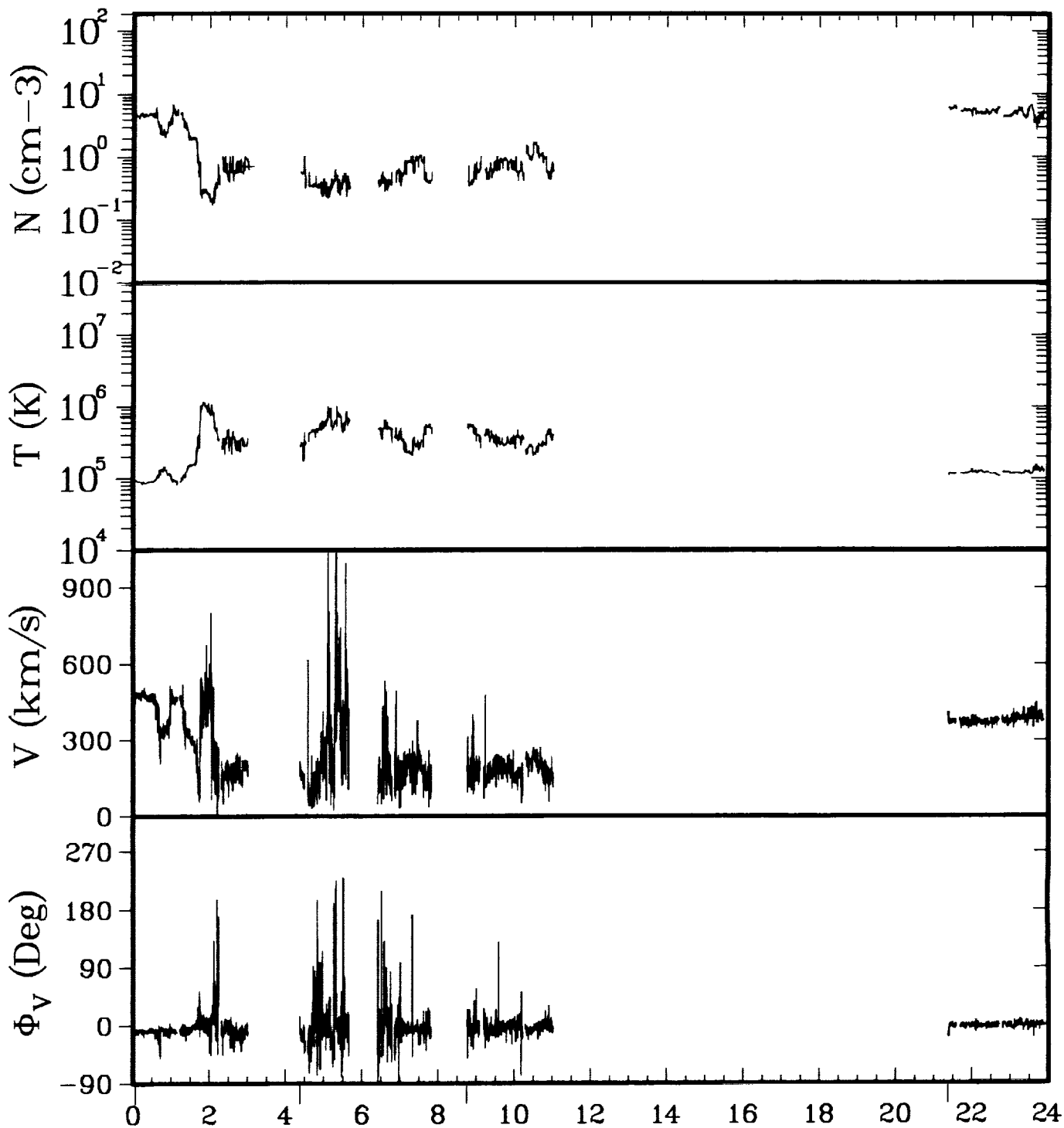

ISEE-3 ELECTRONS 06/11/83

GSEX	-226.6	-226.8	-226.9	-227.3
Y	-0.9	-0.8	-0.8	-0.5
Z	-22.9	-22.8	-22.8	-22.7
GSMY	5.4	1.2	-3.4	6.0
Z	-22.2	-22.8	-22.6	-21.9

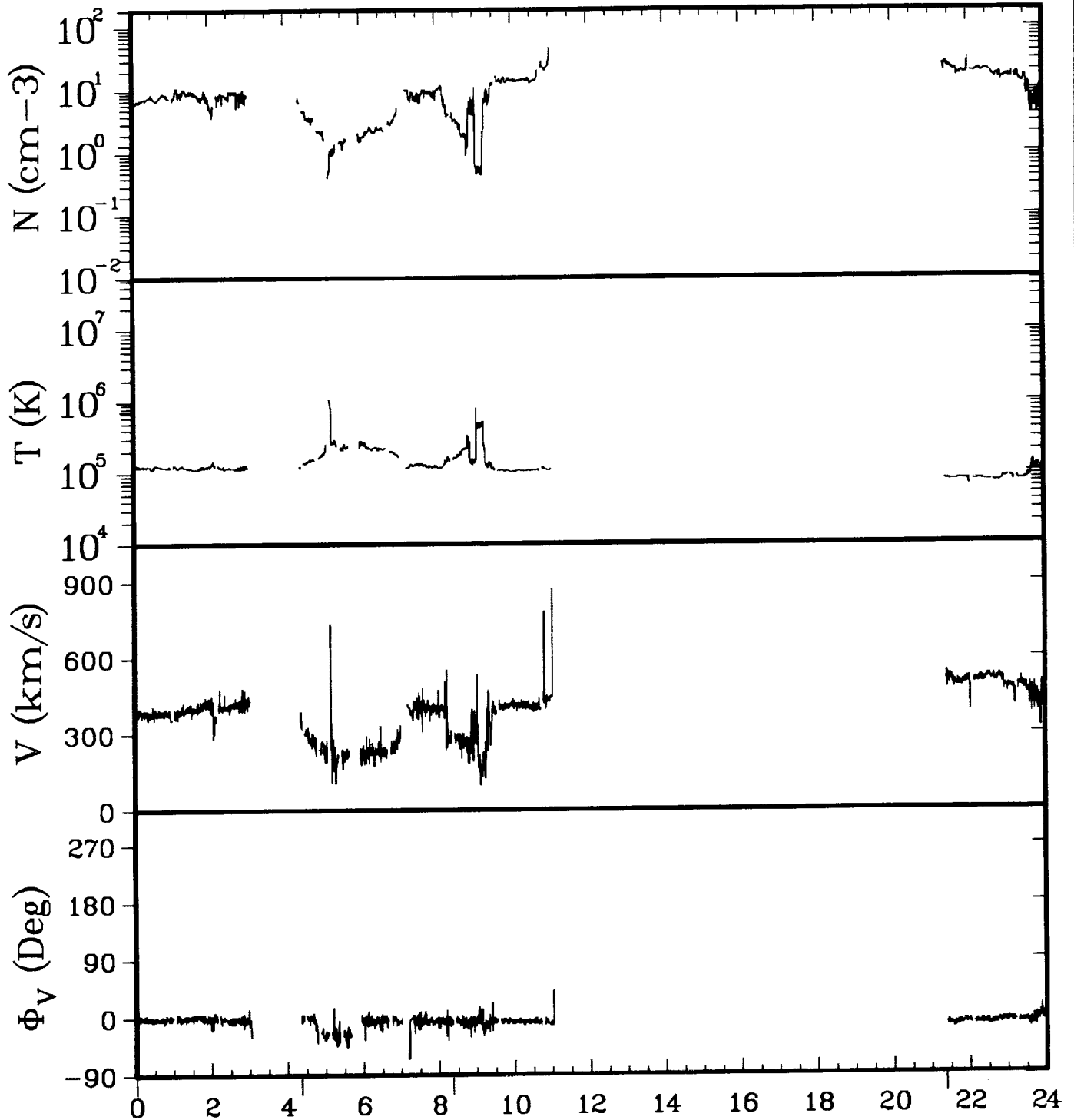

ISEE-3 ELECTRONS 06/12/83

GSEX	-227.4	-227.6	-227.7	-228.1
Y	-0.5	-0.4	-0.3	-0.1
Z	-22.7	-22.6	-22.6	-22.4
GSMY	5.7	1.5	-2.8	6.2
Z	-21.9	-22.6	-22.4	-21.5

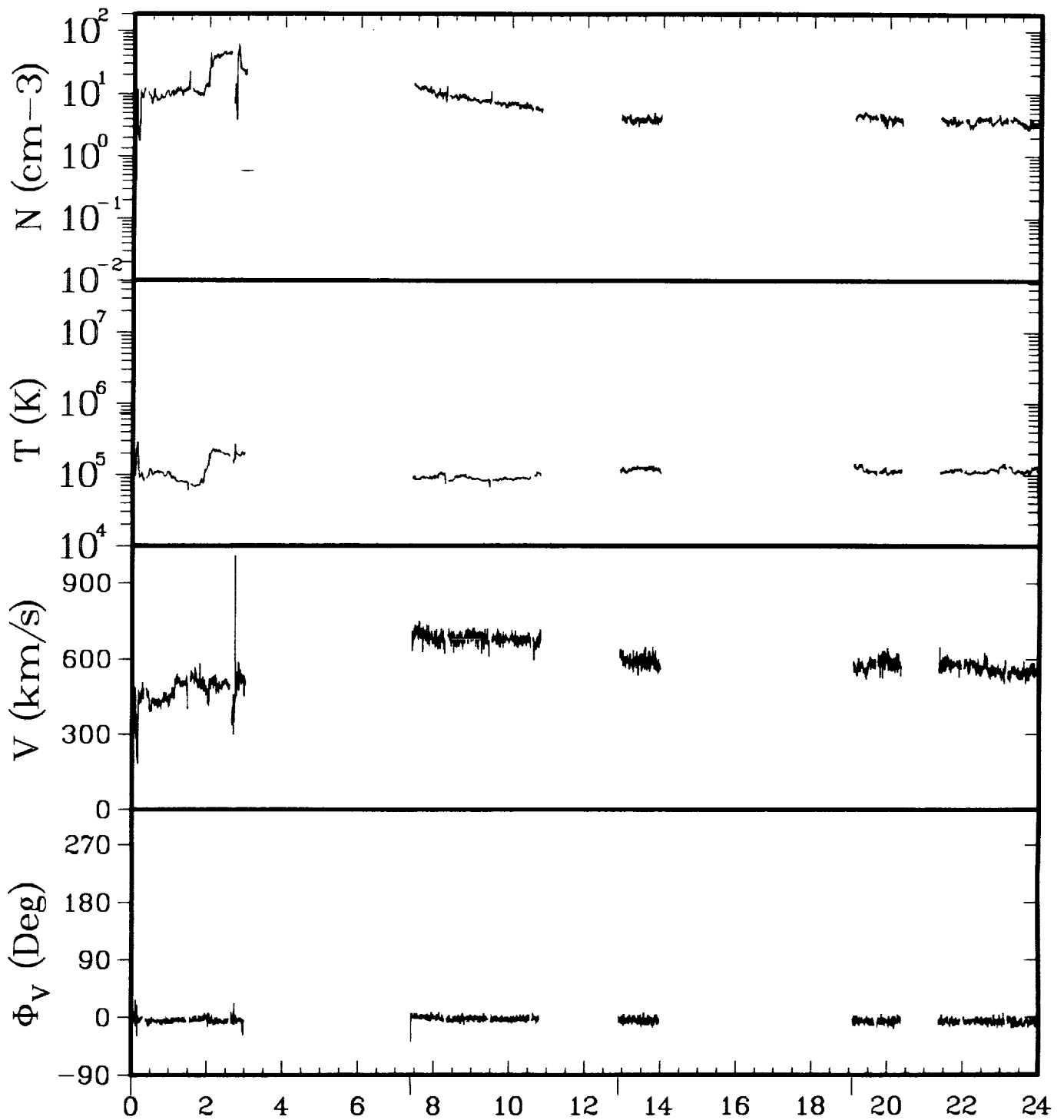

ISEE-3 ELECTRONS 06/13/83

GSEX	-228.2	-228.4	-228.6	-228.8
Y	0.0	0.1	0.2	0.3
Z	-22.4	-22.3	-22.2	-22.2
GSMY	5.9	-1.7	-2.8	4.9
Z	-21.6	-22.2	-22.1	-21.6

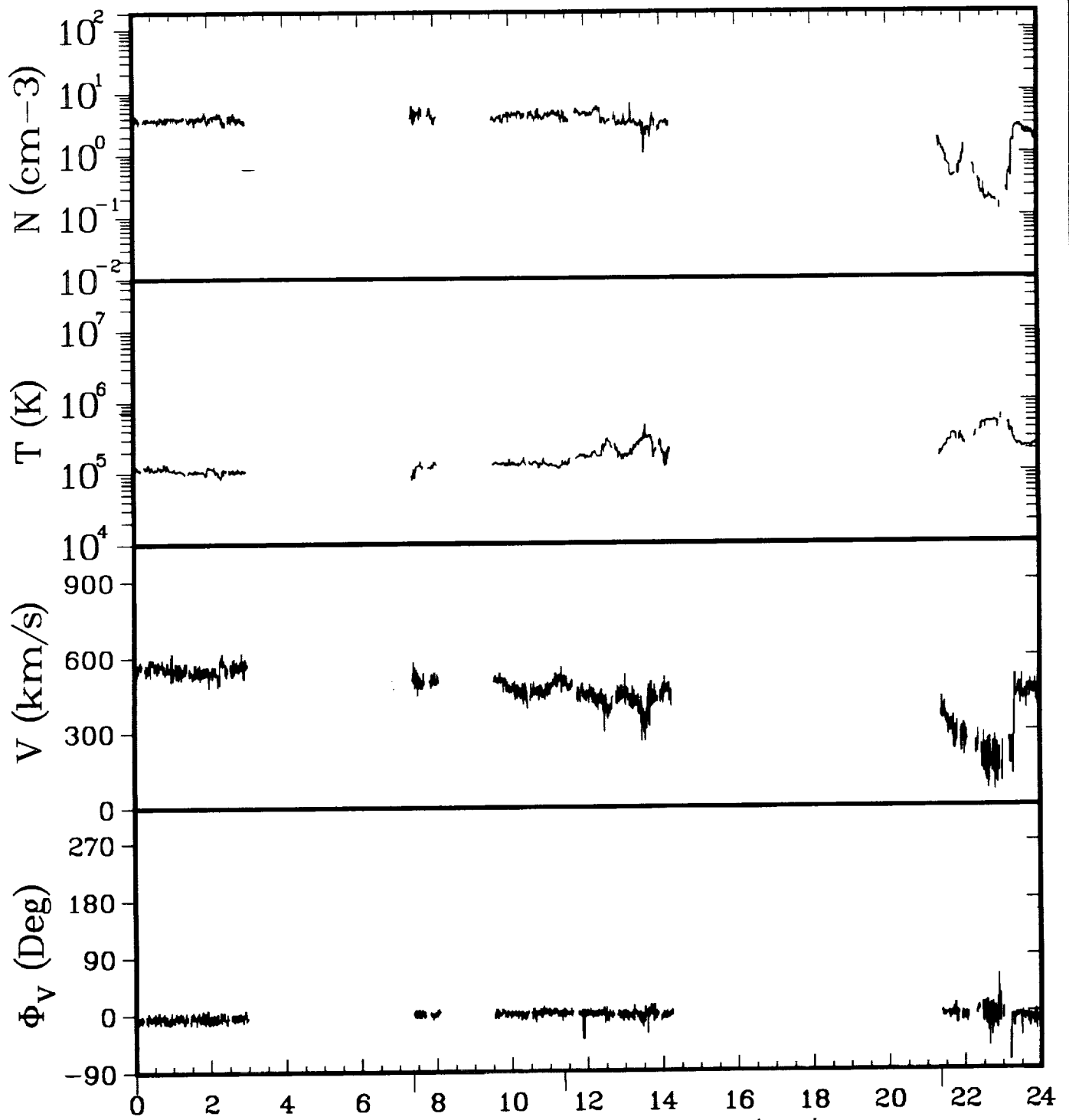

ISEE-3 ELECTRONS 06/14/83

GSEX	-229.0	-229.2	-229.3	-229.6
Y	0.4	0.6	0.7	0.8
Z	-22.1	-22.0	-22.0	-21.8
GSMY	6.1	-1.3	-3.1	6.6
Z	-21.3	-22.0	-21.8	-20.8

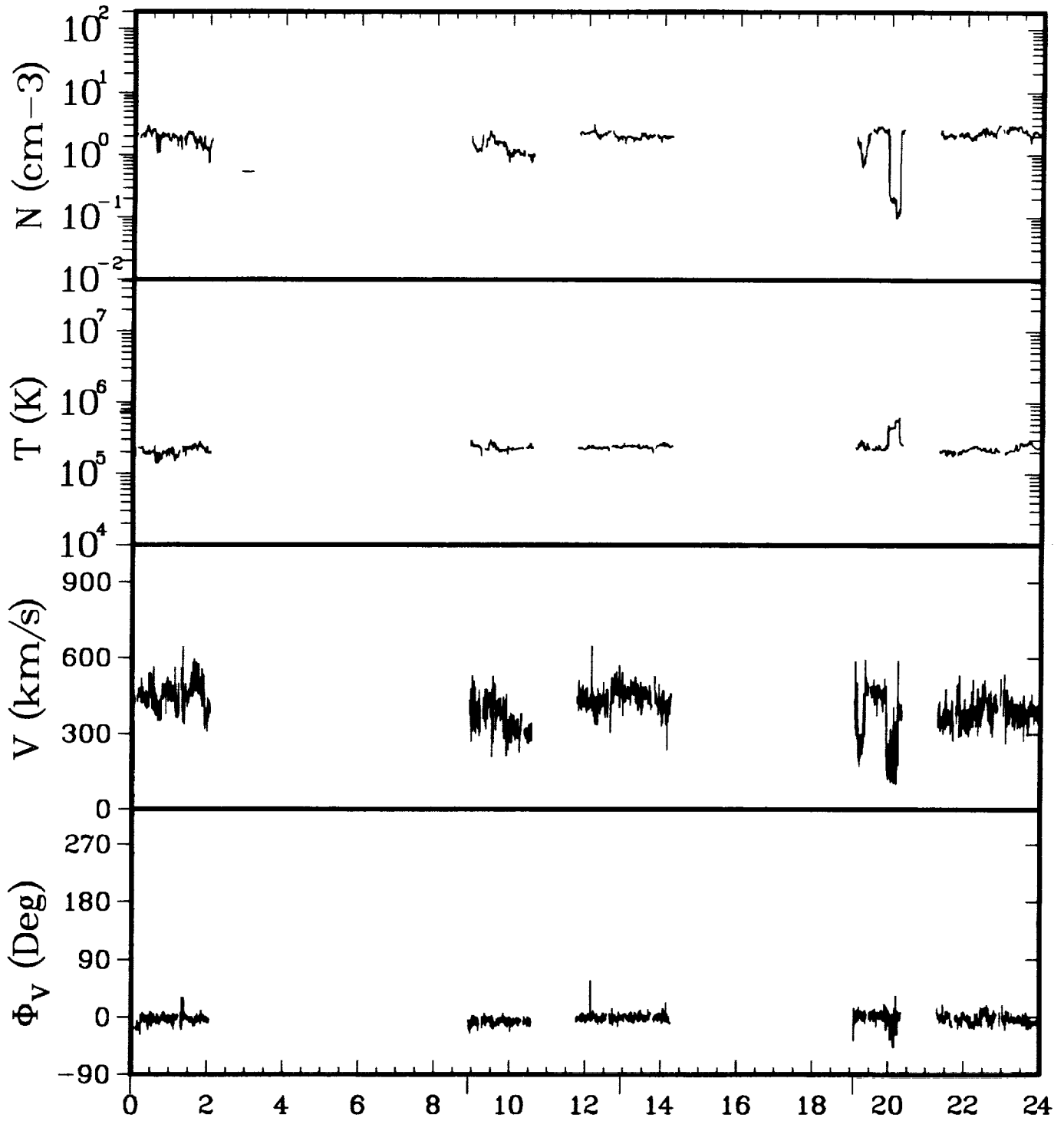

ISEE-3 ELECTRONS 06/15/83

GSEX	-229.7	-230.0	-230.1	-230.3
Y	0.9	1.1	1.1	1.3
Z	-21.8	-21.7	-21.6	-21.5
GSMY	6.3	-2.1	-2.1	5.3
Z	-20.9	-21.6	-21.6	-20.9

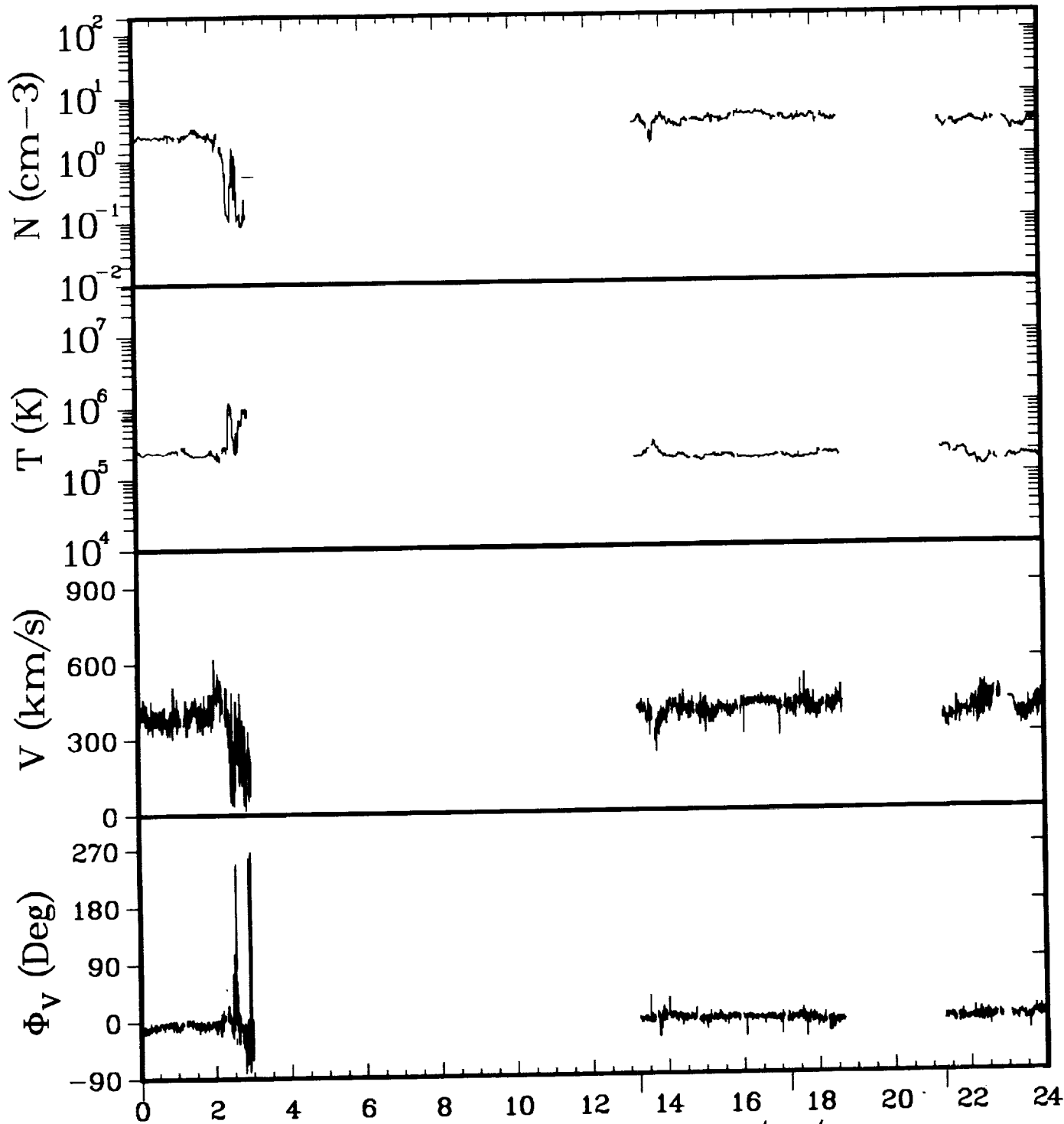

ISEE-3 ELECTRONS 06/16/83

GSEX	-230.5	-230.9	-231.0	-231.1
Y	1.3	1.6	1.7	1.7
Z	-21.5	-21.3	-21.2	-21.2
GSMY	6.5	-1.5	3.3	7.0
Z	-20.5	-21.3	-21.0	-20.0

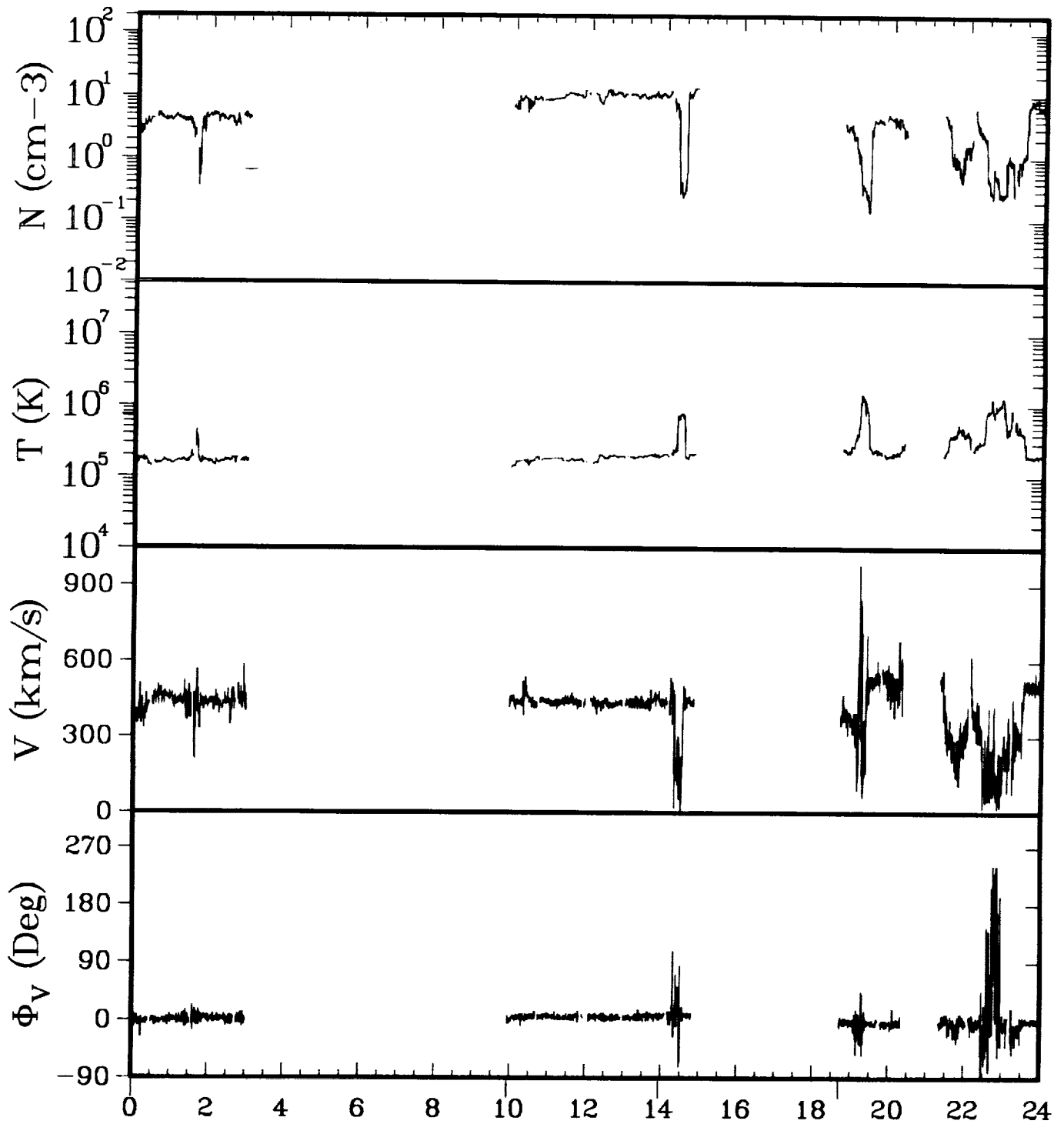

ISEE-3 ELECTRONS 06/17/83

GSEX	-231.2	-231.5	-231.6	-231.7
Y	1.8	2.0	2.0	2.1
Z	-21.1	-21.0	-20.9	-20.8
GSMY	6.7	-1.9	-0.6	5.3
Z	-20.1	-21.0	-21.0	-20.2

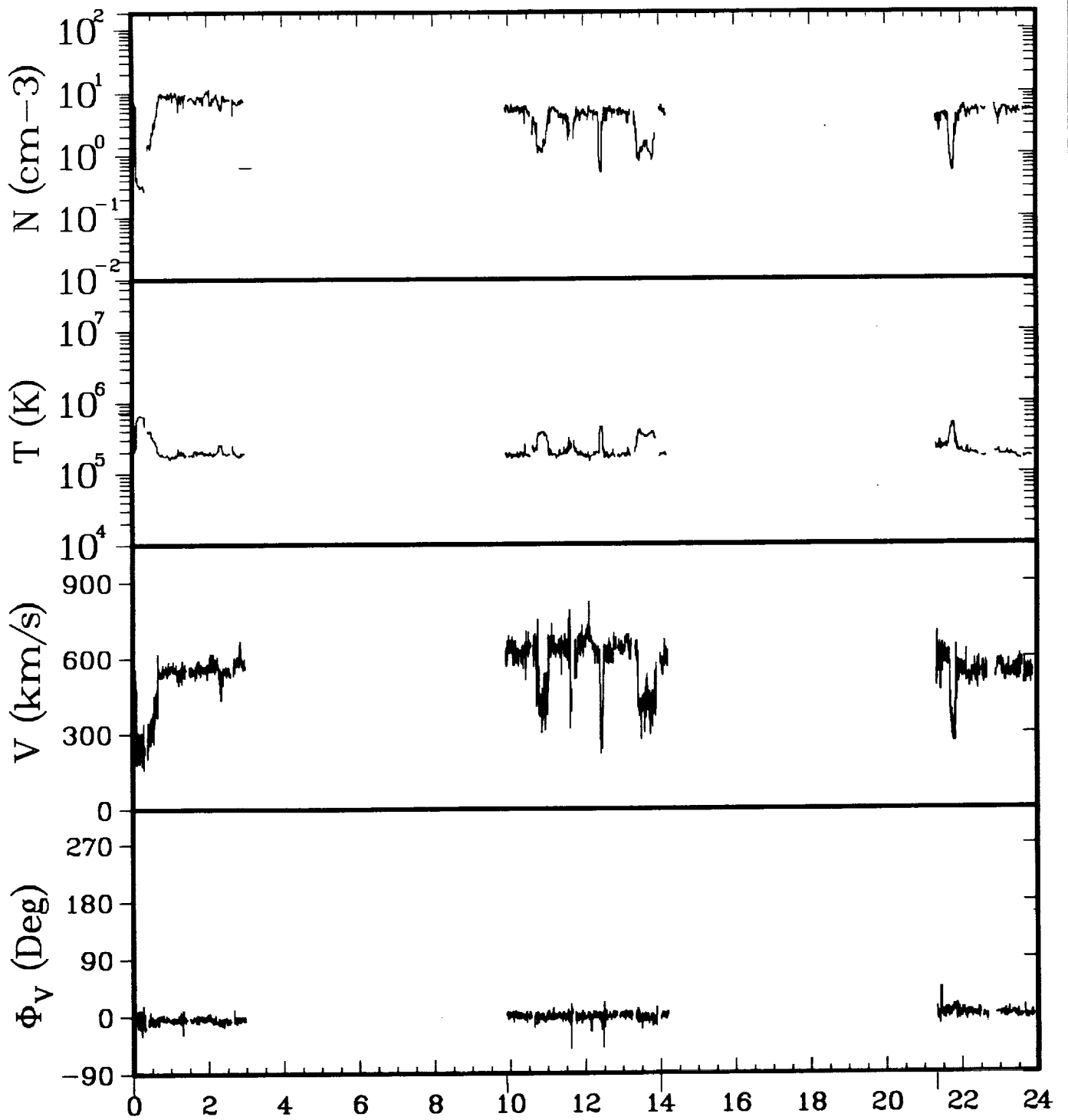

ISEE-3 ELECTRONS 06/18/83

GSEX	-231.9	-232.2	-232.3	-232.5
Y	2.2	2.4	2.4	2.5
Z	-20.7	-20.6	-20.5	-20.4
GSMY	6.9	-1.6	-0.2	7.3
Z	-19.7	-20.7	-20.7	-19.2

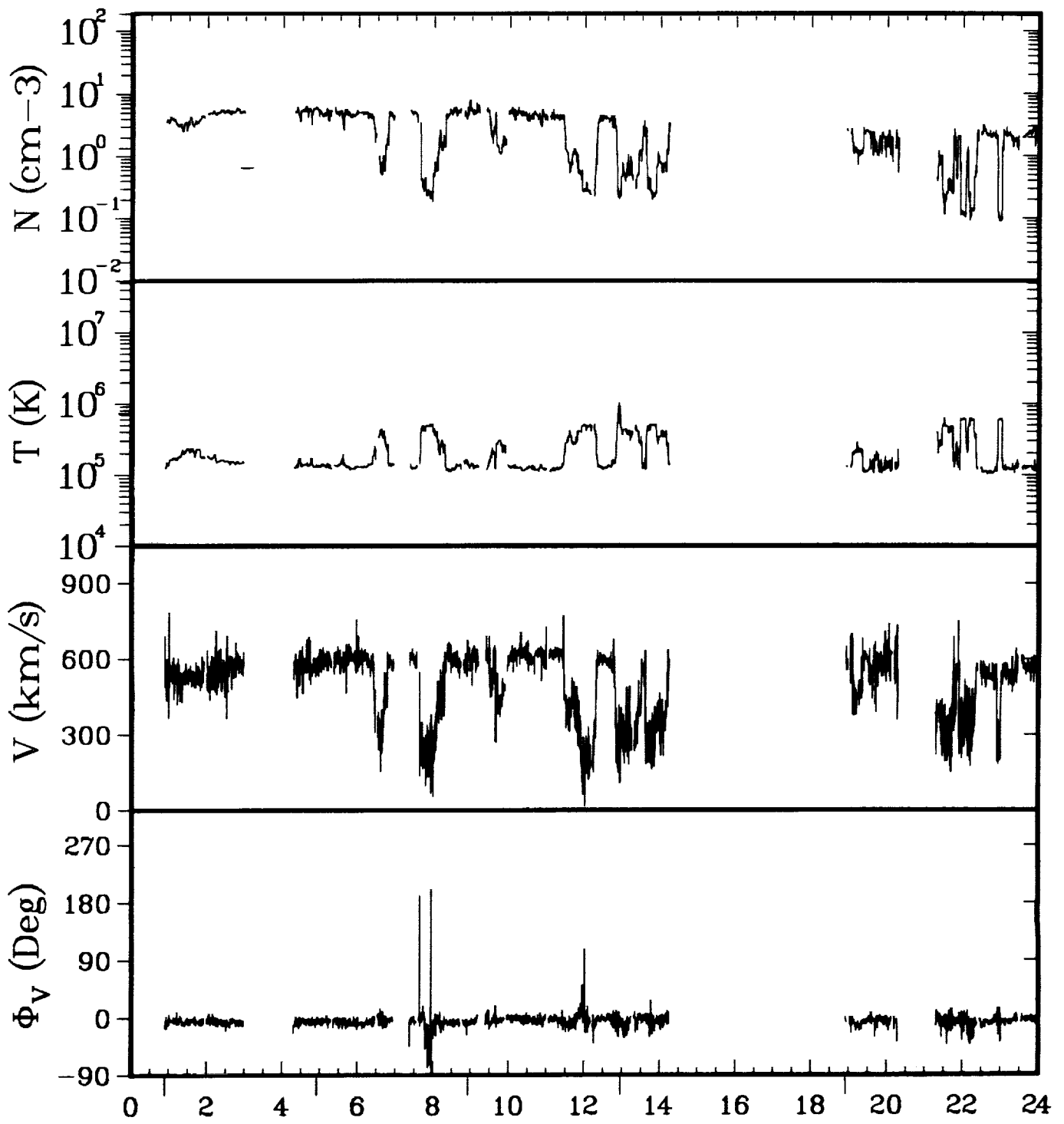

ISEE-3 ELECTRONS 06/19/83

GSEX	-232.6	-232.7	-232.8	-232.9	-233.0
Y	2.6	2.7	2.7	2.8	2.9
Z	-20.3	-20.3	-20.2	-20.1	-20.0
GSMY	6.6	2.7	-0.9	-0.8	5.9
Z	-19.4	-20.3	-20.4	-20.3	-19.3

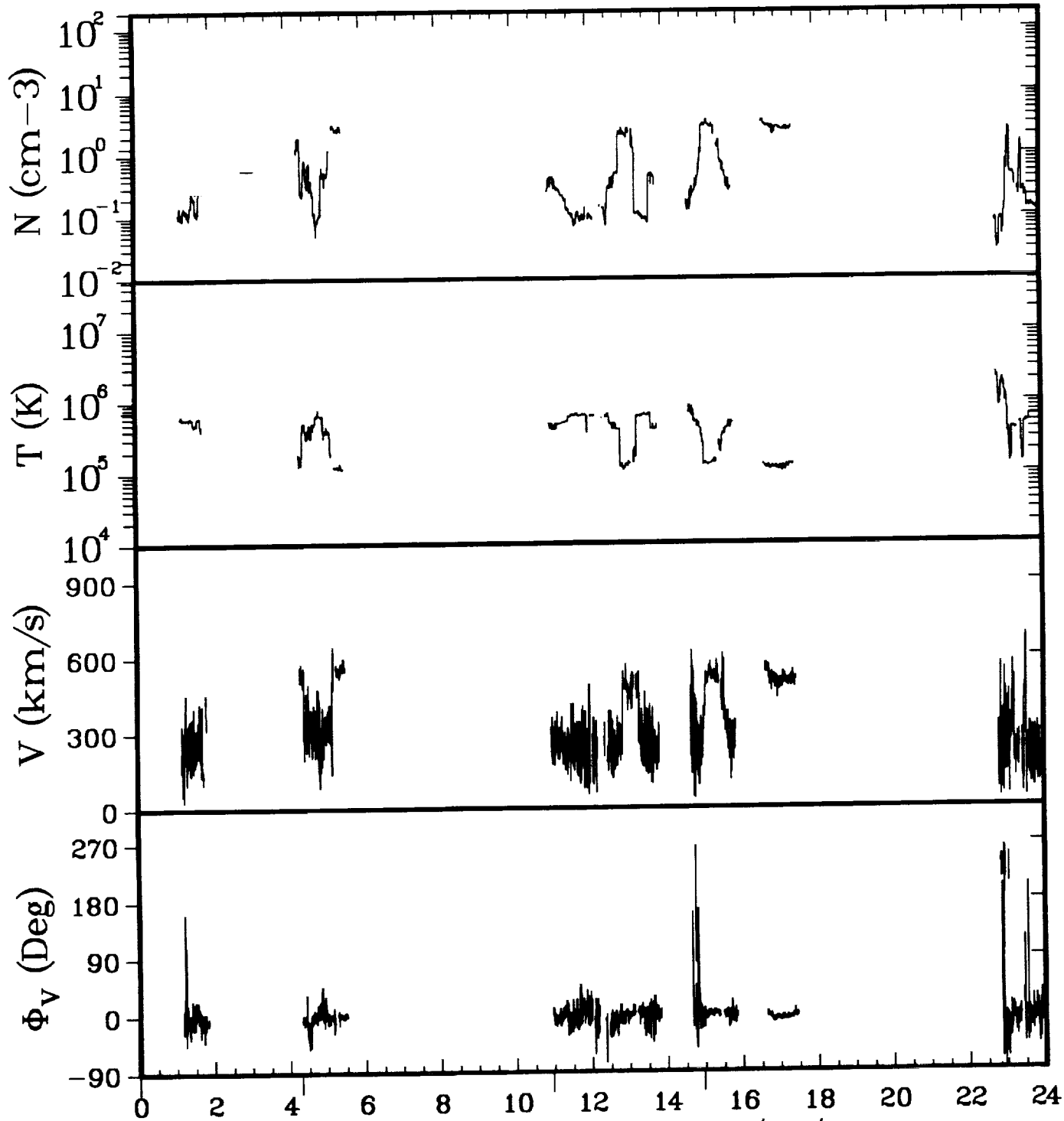

ISEE-3 ELECTRONS 06/20/83

GSEX	-233.2	-233.3	-233.4	-233.5
Y	3.0	3.0	3.1	3.2
Z	-19.9	-19.9	-19.7	-19.7
GSMY	7.2	3.6	-1.1	1.3
Z	-18.8	-19.7	-19.9	-19.9

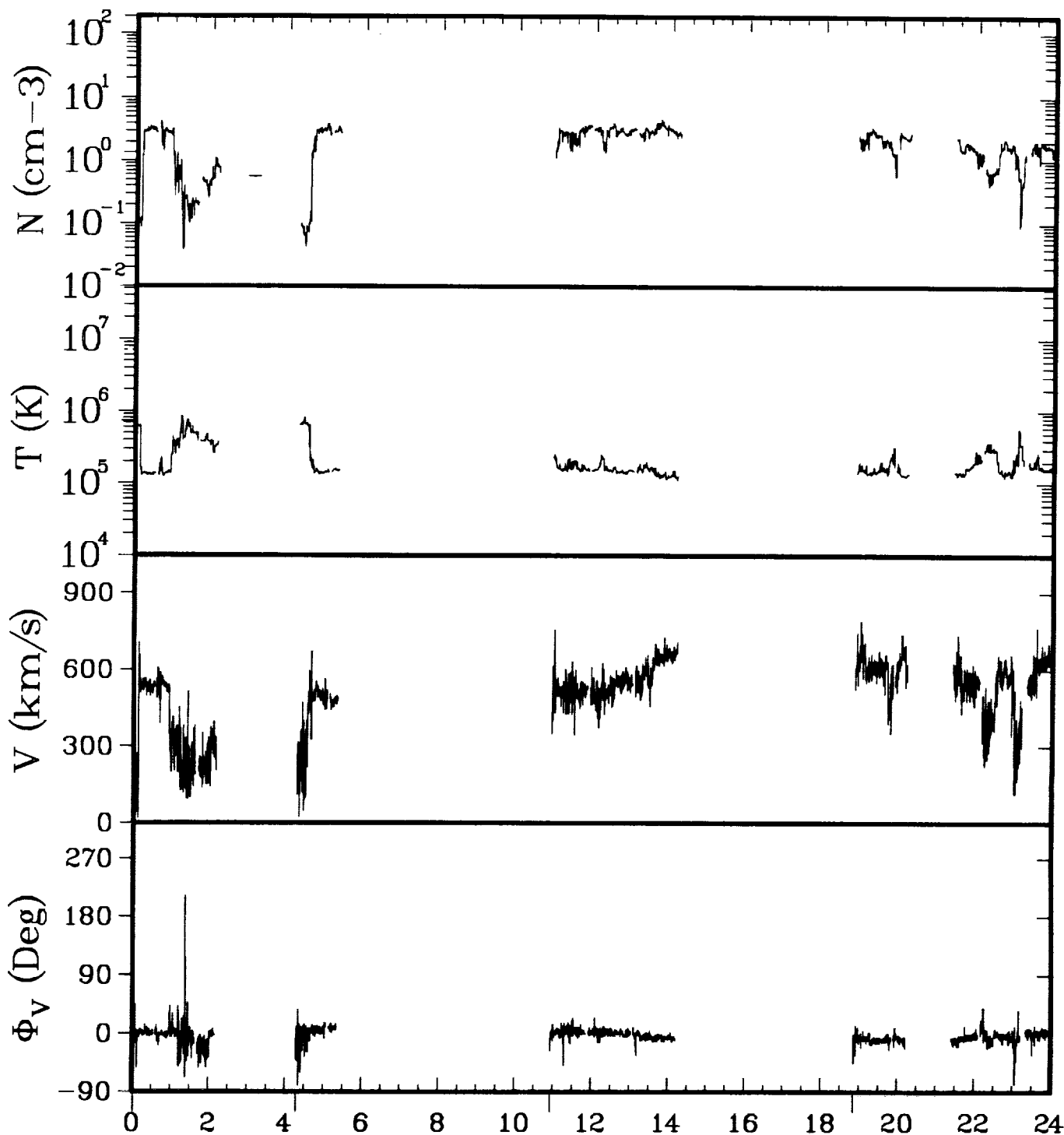

ISEE-3 ELECTRONS 06/21/83

GSEX	-233.7	-233.8	-234.0	-234.2
Y	3.3	3.4	3.5	3.6
Z	-19.5	-19.4	-19.3	-19.1
GSMY	7.3	3.8	-0.8	6.1
Z	-18.4	-19.3	-19.6	-18.5

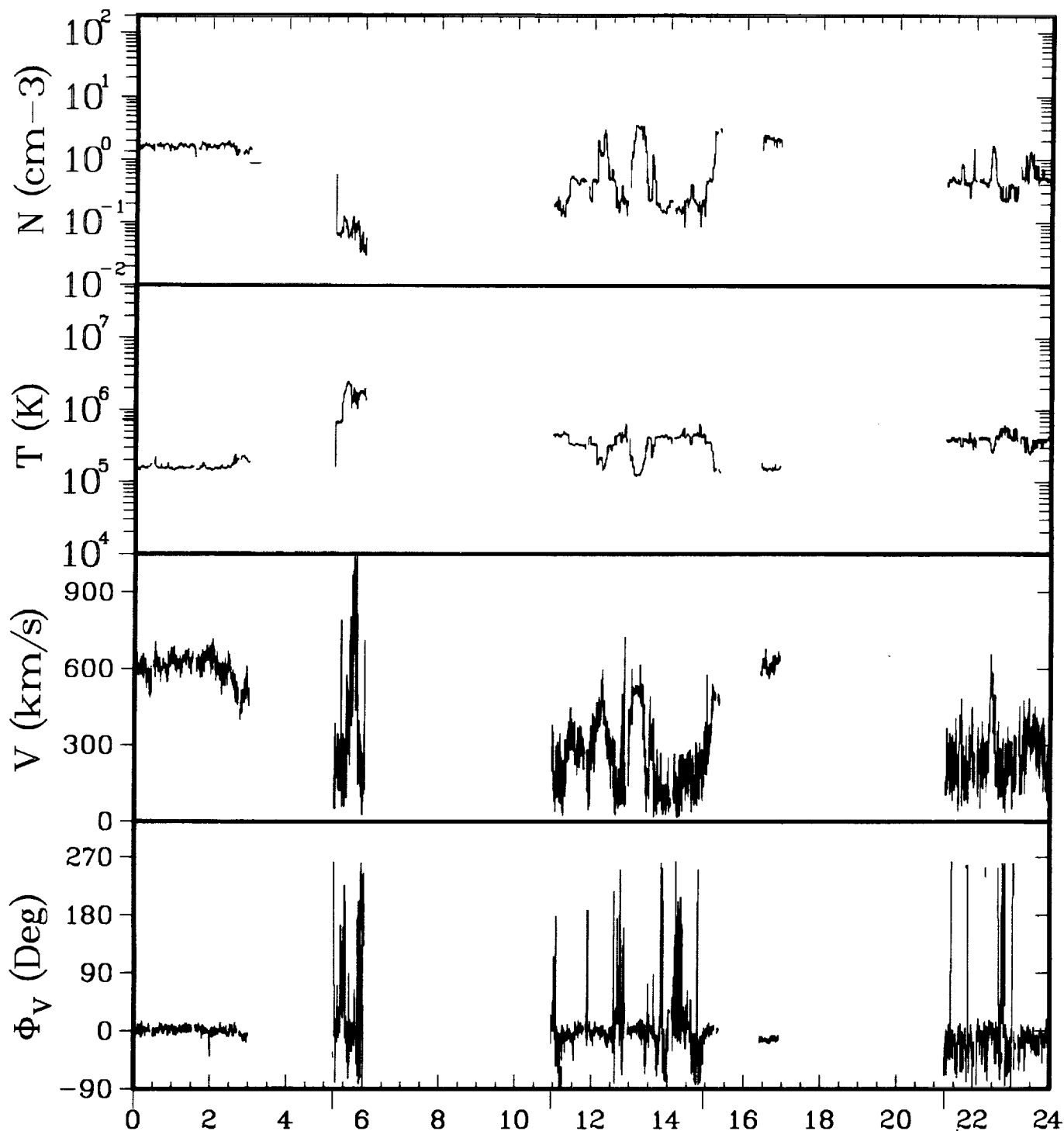

ISEE-3 ELECTRONS 06/22/83

GSEX	-234.3	-234.4	-234.5	-234.6	-234.7
Y	3.7	3.7	3.8	3.9	4.0
Z	-19.0	-18.9	-18.8	-18.7	-18.6
GSMY	7.4	3.1	-0.5	1.8	7.7
Z	-17.9	-19.0	-19.2	-19.0	-17.4

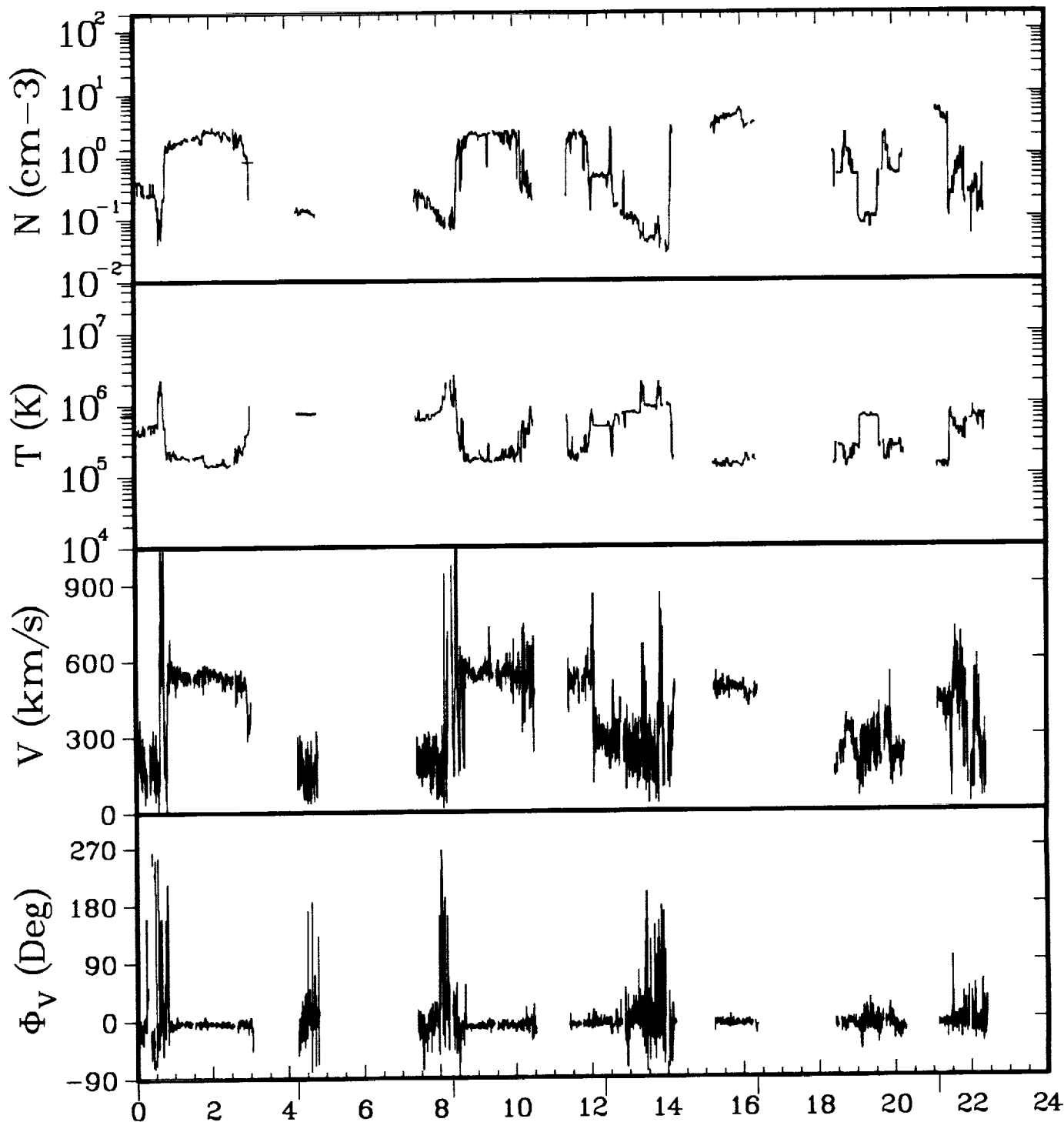

ISEE-3 ELECTRONS 06/23/83

GSEX	-234.7	-234.8	-234.9	-234.9	-235.0	-235.1
Y	4.0	4.1	4.1	4.2	4.2	4.3
Z	-18.6	-18.5	-18.4	-18.3	-18.2	-18.1
GSMY	7.5	4.3	0.6	0.0	3.7	7.8
Z	-17.4	-18.4	-18.8	-18.8	-18.3	-16.9

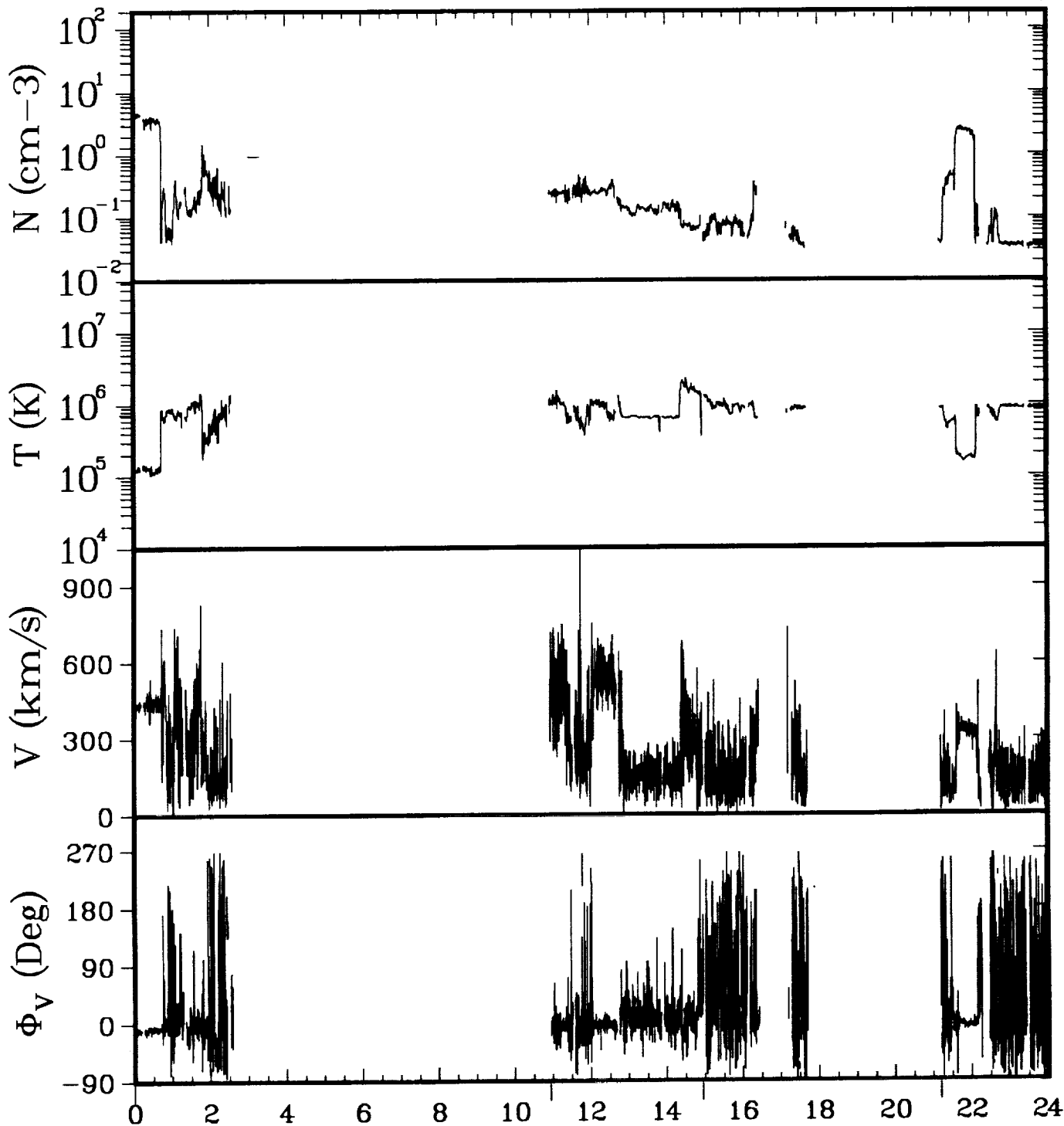

ISEE-3 ELECTRONS 06/24/83

GSEX	-235.1	-235.3	-235.4	-235.4
Y	4.3	4.5	4.5	4.6
Z	-18.1	-17.8	-17.7	-17.6
GSMY	7.6	0.1	2.3	7.9
Z	-16.9	-18.4	-18.2	-16.4

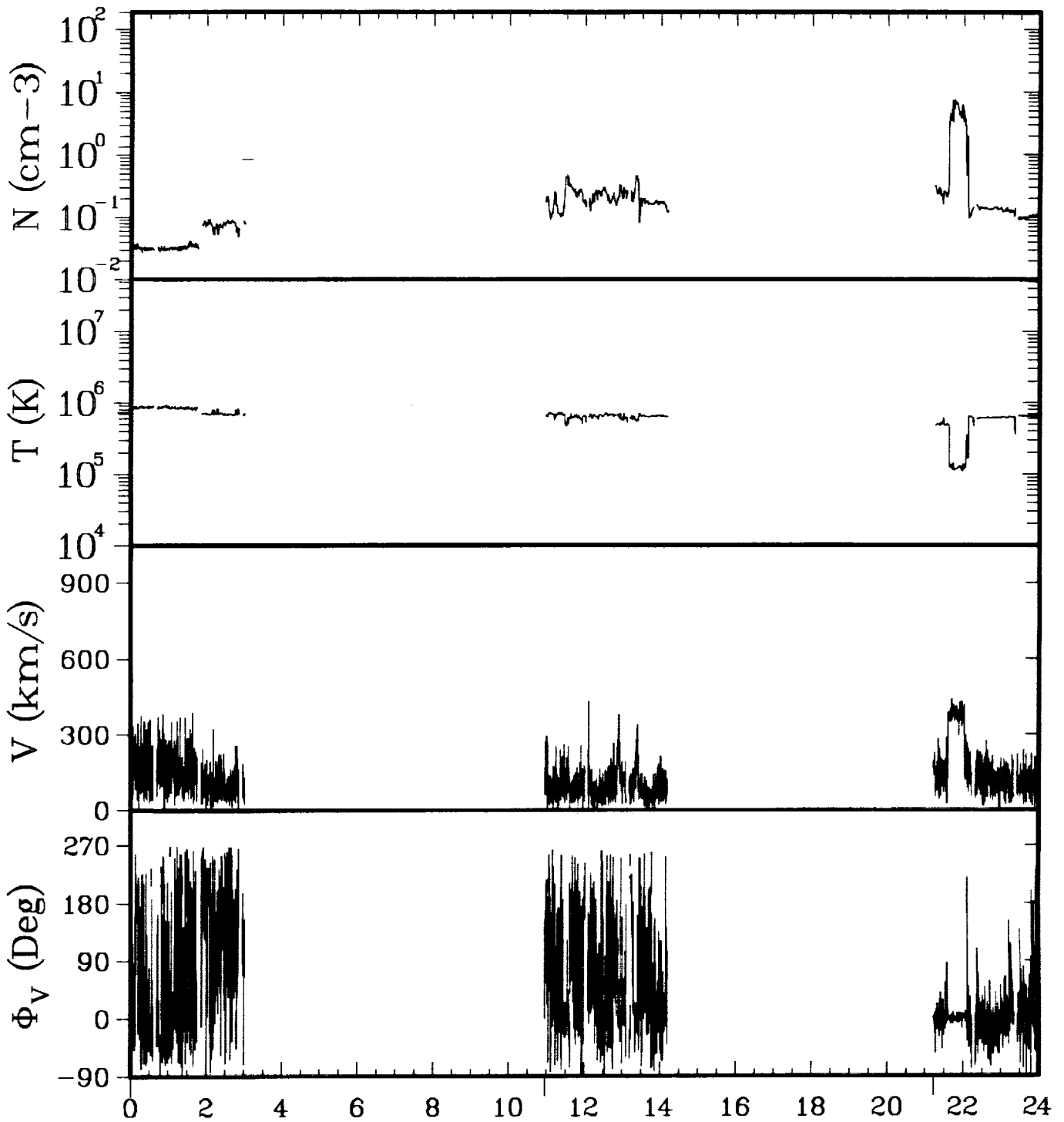

ISEE-3 ELECTRONS 06/25/83

GSEX	-235.5	-235.6	-235.7
Y	4.6	4.8	4.9
Z	-17.5	-17.3	-17.1
GSMY	7.7	0.4	8.0
Z	-16.4	-17.9	-15.8

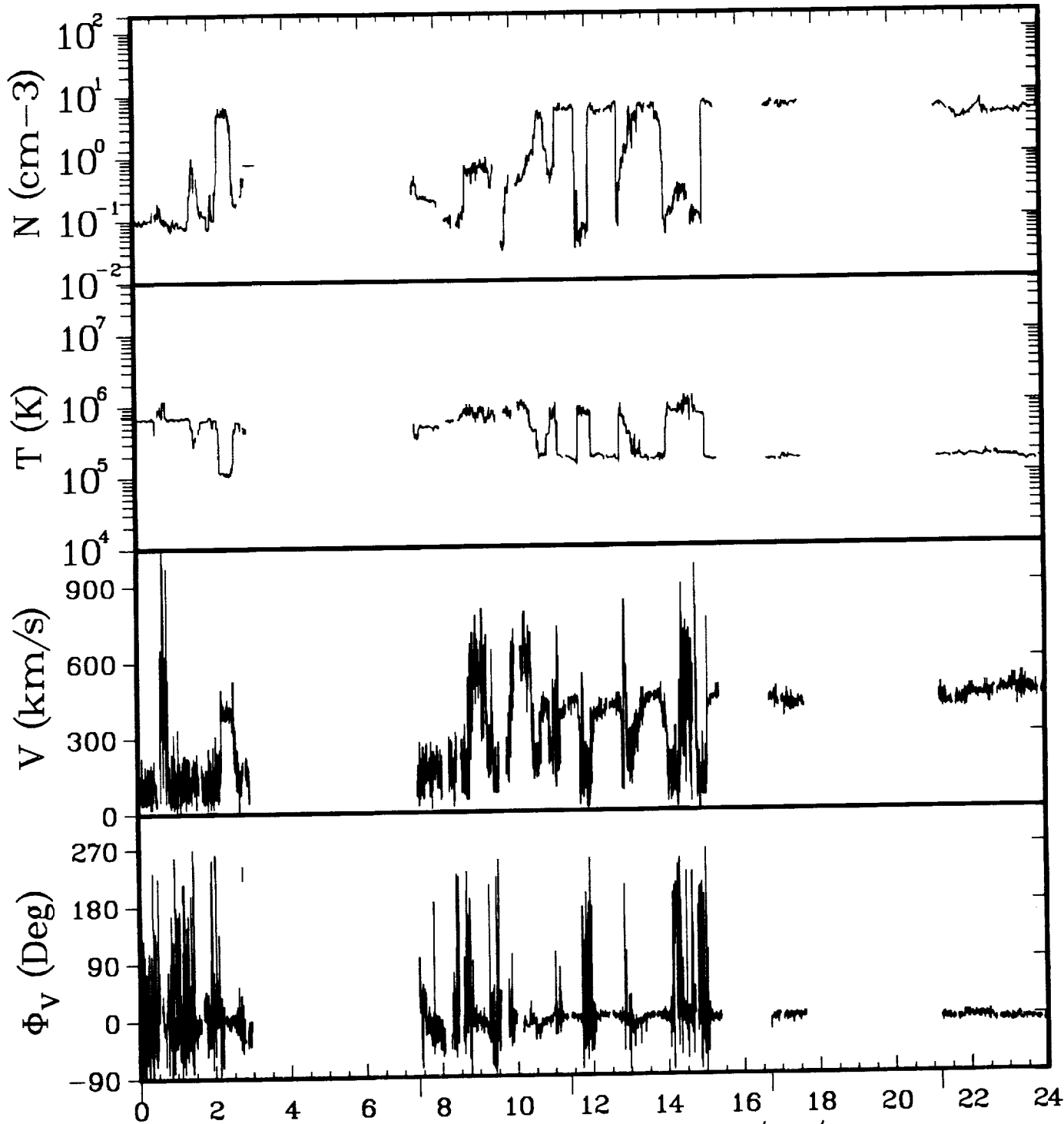

ISEE-3 ELECTRONS 06/26/83

GSEX	-235.8	-235.8	-235.9	-235.9	-236.0
Y	5.0	5.1	5.1	5.2	5.3
Z	-17.0	-16.8	-16.7	-16.6	-16.5
GSMY	7.9	2.2	0.7	4.7	8.1
Z	-15.9	-17.4	-17.5	-16.8	-15.3

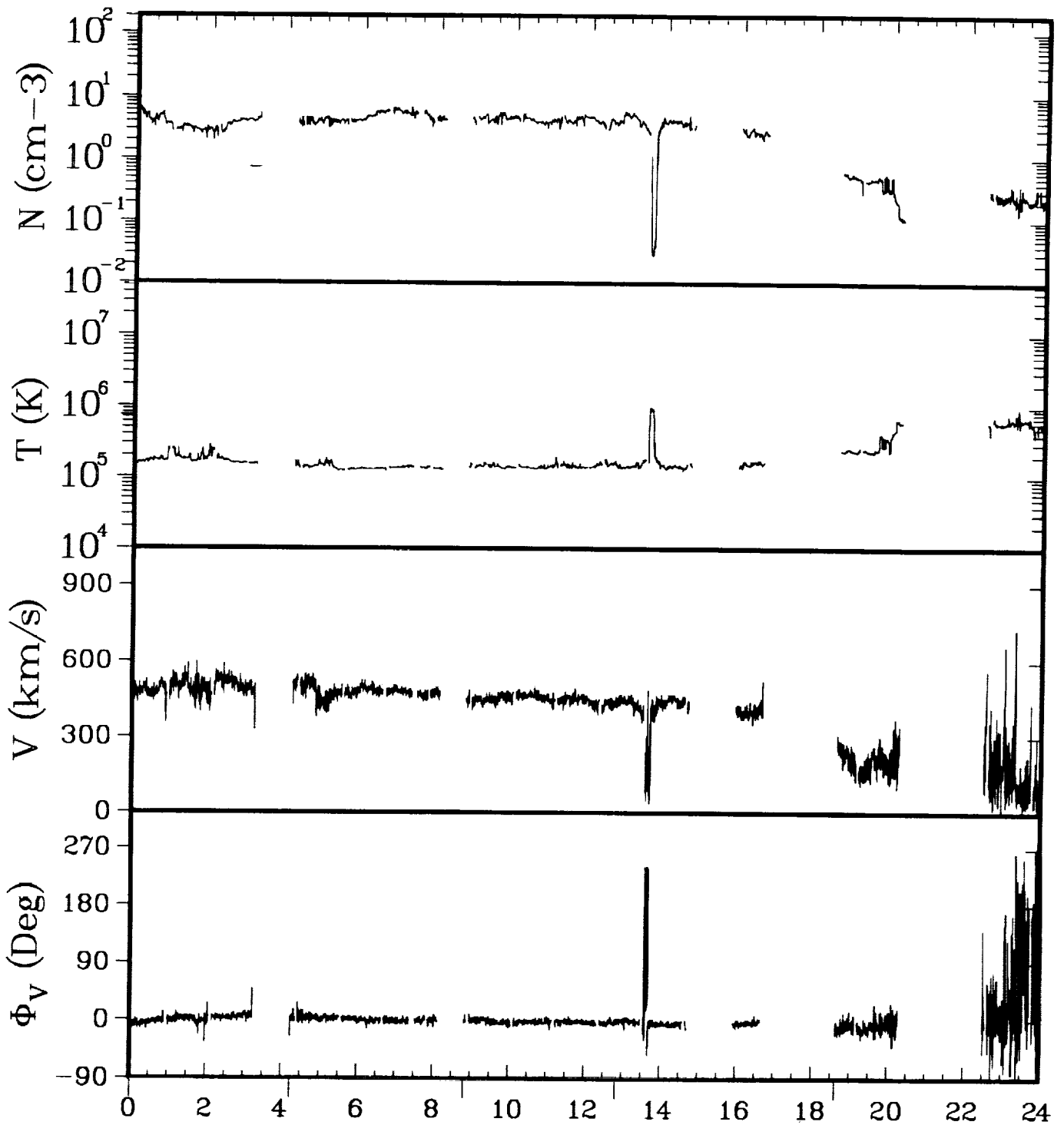

ISEE-3 ELECTRONS 06/27/83

GSEX	-236.0	-236.0	-236.0	-236.1	-236.1
Y	5.3	5.4	5.4	5.5	5.6
Z	-16.4	-16.3	-16.2	-16.1	-16.0
GSMY	8.0	5.1	1.6	1.5	6.8
Z	-15.3	-16.4	-17.0	-17.0	-15.5

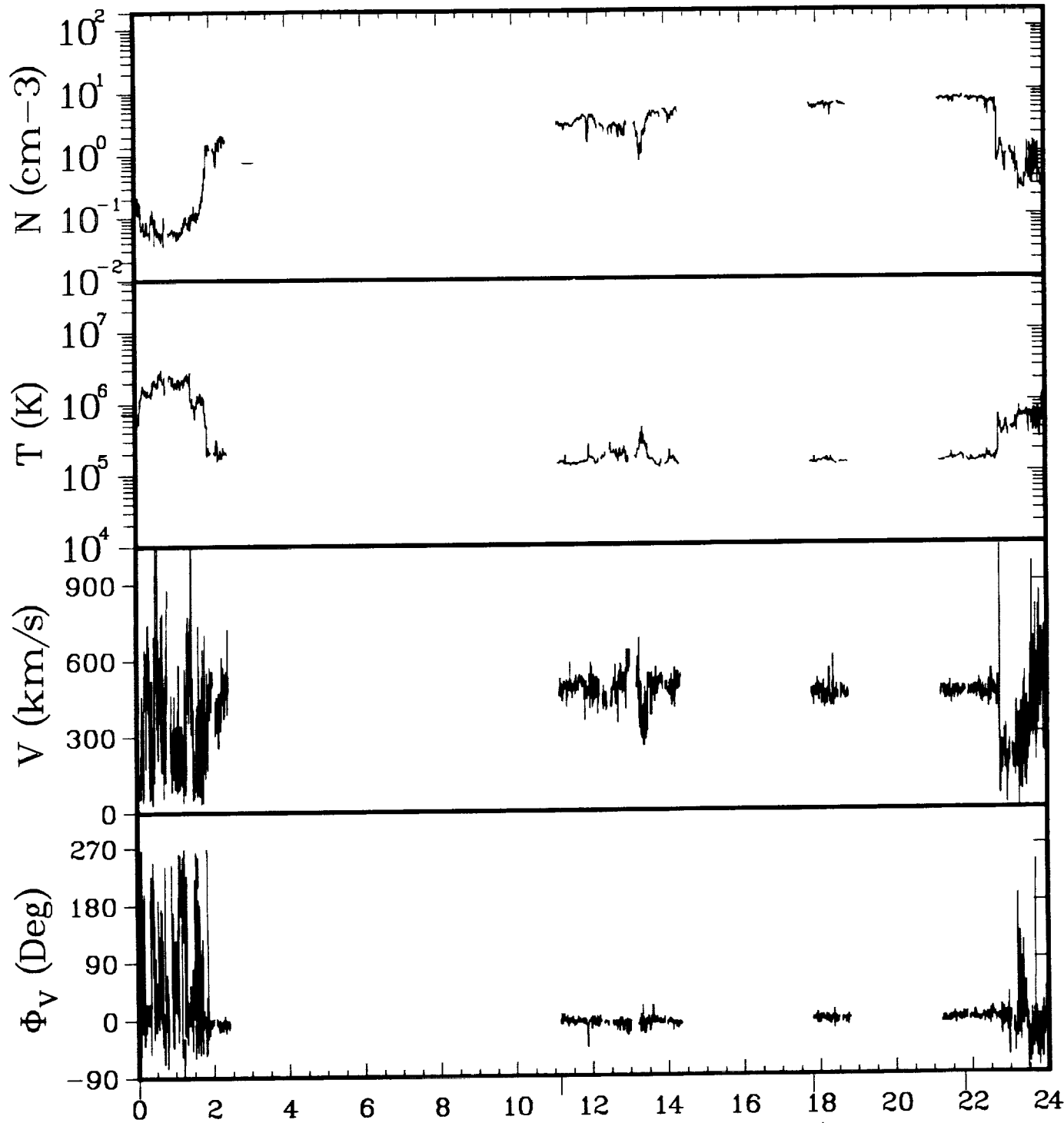

ISEE-3 ELECTRONS 06/28/83

GSEX	-236.1	-236.2	-236.2	-236.2
Y	5.7	5.8	5.9	6.0
Z	-15.8	-15.6	-15.4	-15.3
GSMY	8.1	1.4	6.3	8.5
Z	-14.7	-16.6	-15.2	-14.0

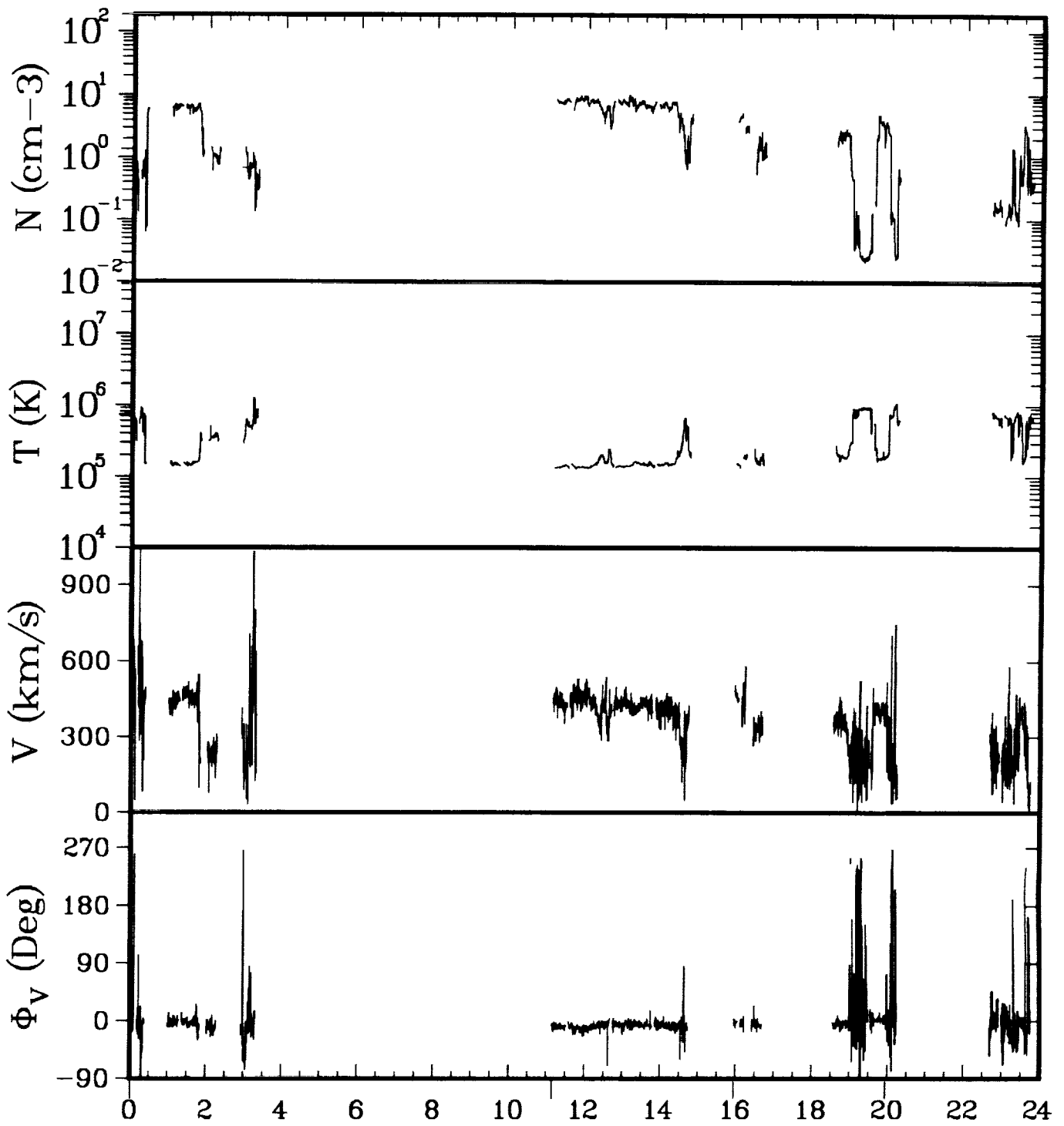

ISEE-3 ELECTRONS 06/29/83

GSEX	-236.3	-236.3	-236.3	-236.3
Y	6.0	6.2	6.3	6.3
Z	-15.2	-15.0	-14.8	-14.7
GSMY	8.3	1.9	4.7	8.1
Z	-14.1	-16.1	-15.4	-13.8

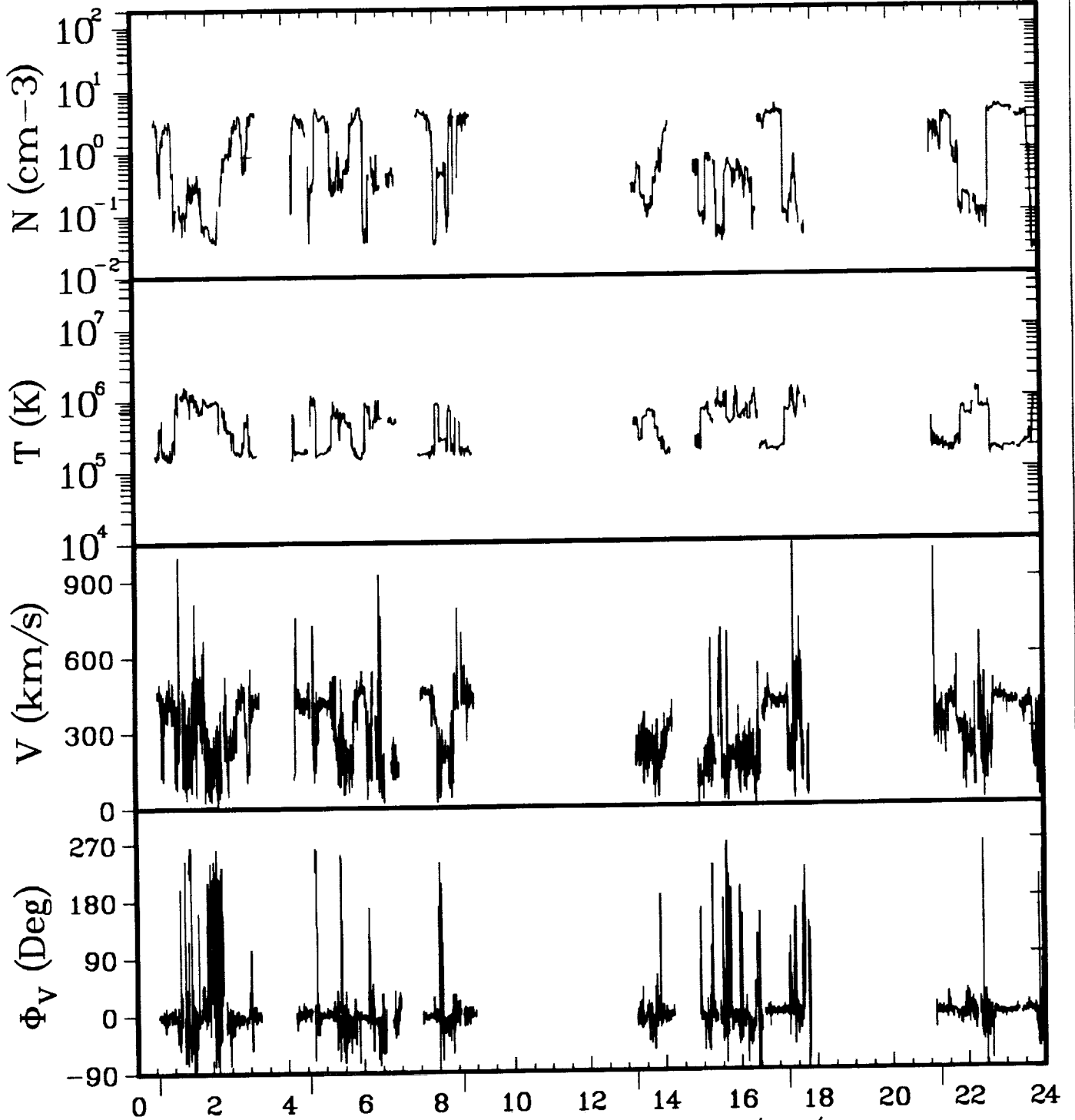

ISEE-3 ELECTRONS 06/30/83

GSEX	-236.3	-236.3	-236.3	-236.3	-236.3	-236.3
Y	6.4	6.5	6.6	6.6	6.7	6.8
Z	-14.6	-14.5	-14.4	-14.3	-14.2	-14.0
GSMY	8.3	5.7	2.9	2.9	6.4	8.8
Z	-13.6	-14.8	-15.6	-15.5	-14.3	-12.9

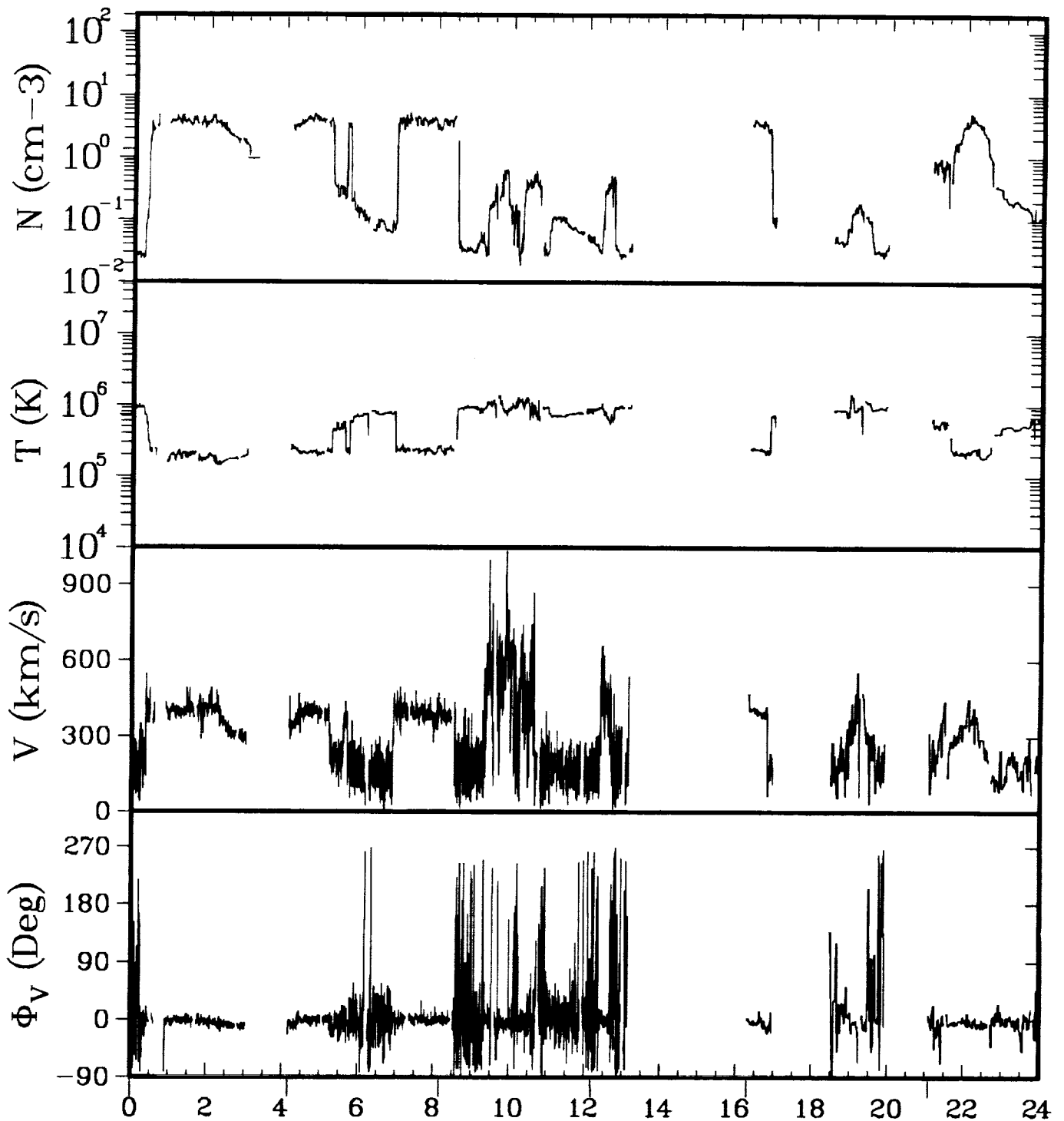

ISEE-3 ELECTRONS 07/01/83

GSEX	-236.3	-236.3	-236.3	-236.3	-236.3	-236.3
Y	6.8	6.9	7.0	7.0	7.1	7.2
Z	-14.0	-13.9	-13.8	-13.6	-13.5	-13.4
GSMY	8.7	6.3	3.5	3.0	5.8	9.0
Z	-12.9	-14.1	-15.0	-15.1	-14.1	-12.2

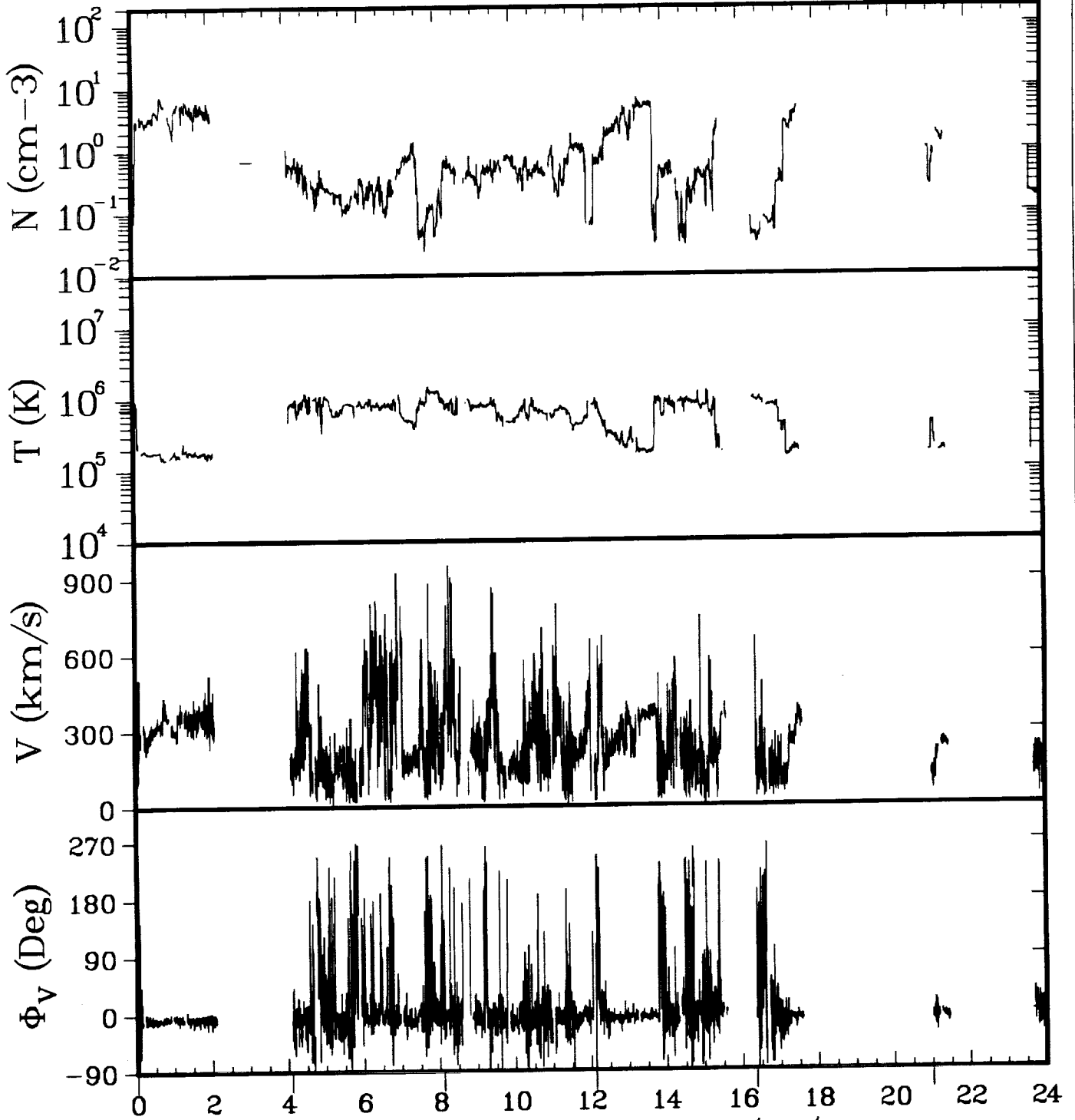

ISEE-3 ELECTRONS 07/04/83

GSEX	-236.1	-236.1	-236.1	-236.1	-236.1	-236.0
Y	8.2	8.3	8.4	8.5	8.6	8.7
Z	-11.9	-11.8	-11.7	-11.5	-11.4	-11.3
GSMY	9.6	7.6	5.2	4.6	7.3	10.0
Z	-10.9	-12.2	-13.4	-13.6	-12.3	-10.2

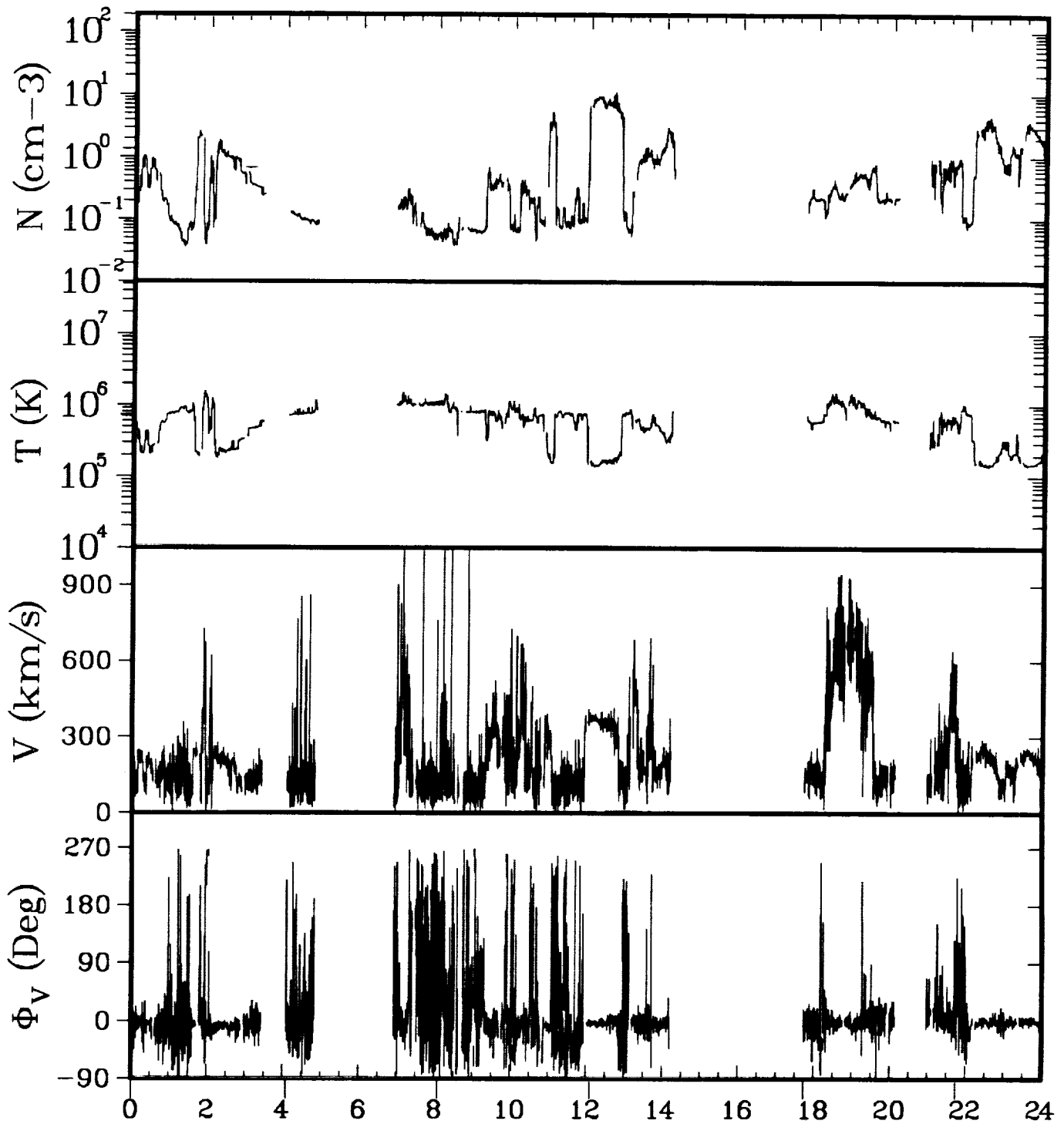

ISEE-3 ELECTRONS 07/05/83

GSEX	-236.0	-236.0	-236.0	-236.0	-235.9	-235.9
Y	8.8	8.9	8.9	9.0	9.2	9.3
Z	-11.2	-11.1	-10.9	-10.8	-10.6	-10.5
GSMY	9.9	8.1	5.8	5.3	8.8	10.5
Z	-10.1	-11.6	-12.9	-13.1	-10.9	-9.3

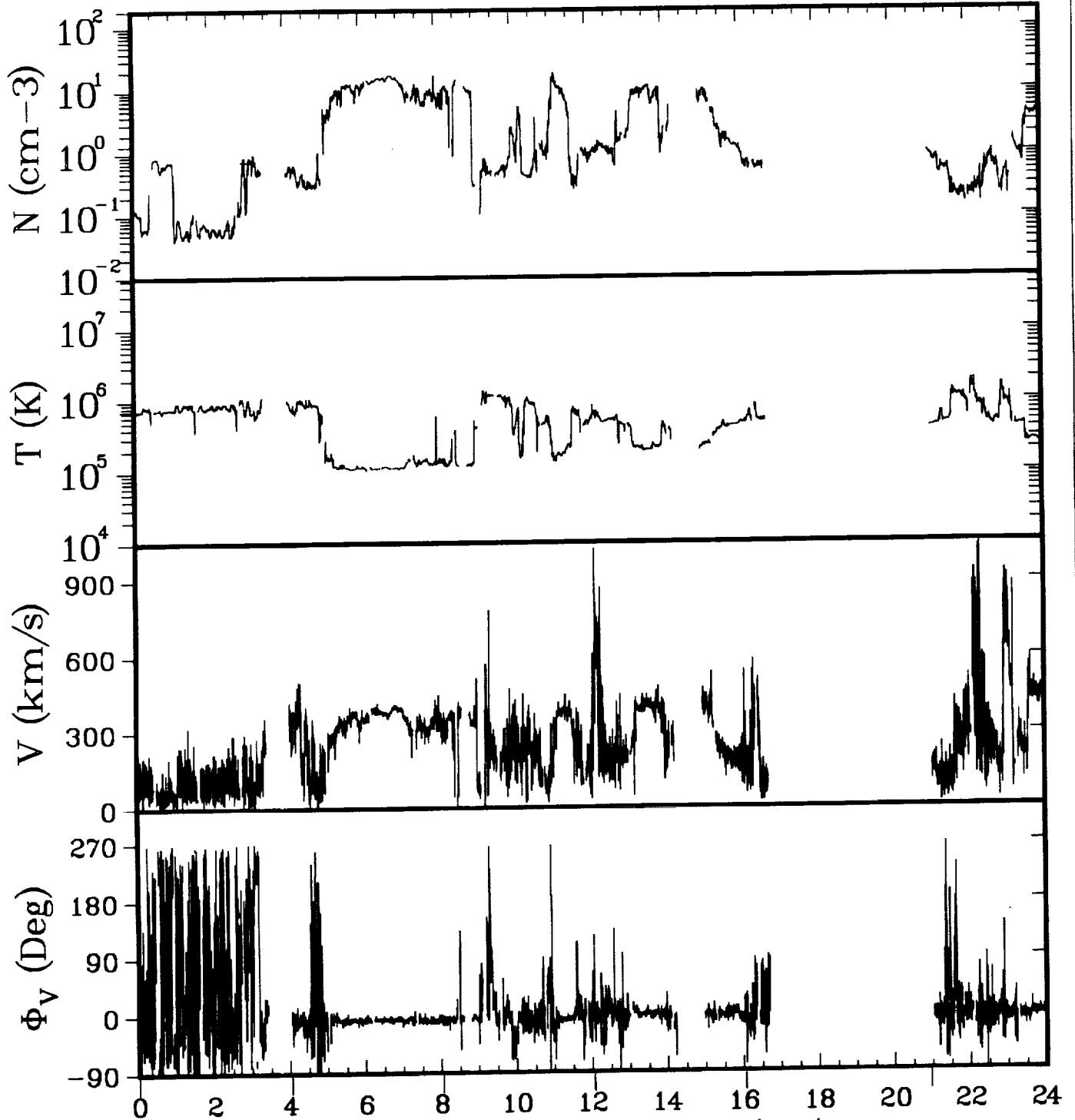

ISEE-3 ELECTRONS 07/06/83

GSEX	-235.9	-235.9	-235.8	-235.8	-235.8	-235.8
Y	9.3	9.4	9.5	9.6	9.7	9.8
Z	-10.4	-10.3	-10.2	-10.1	-9.9	-9.8
GSMY	10.3	8.7	6.5	6.0	8.2	10.8
Z	-9.4	-10.9	-12.3	-12.6	-11.2	-8.7

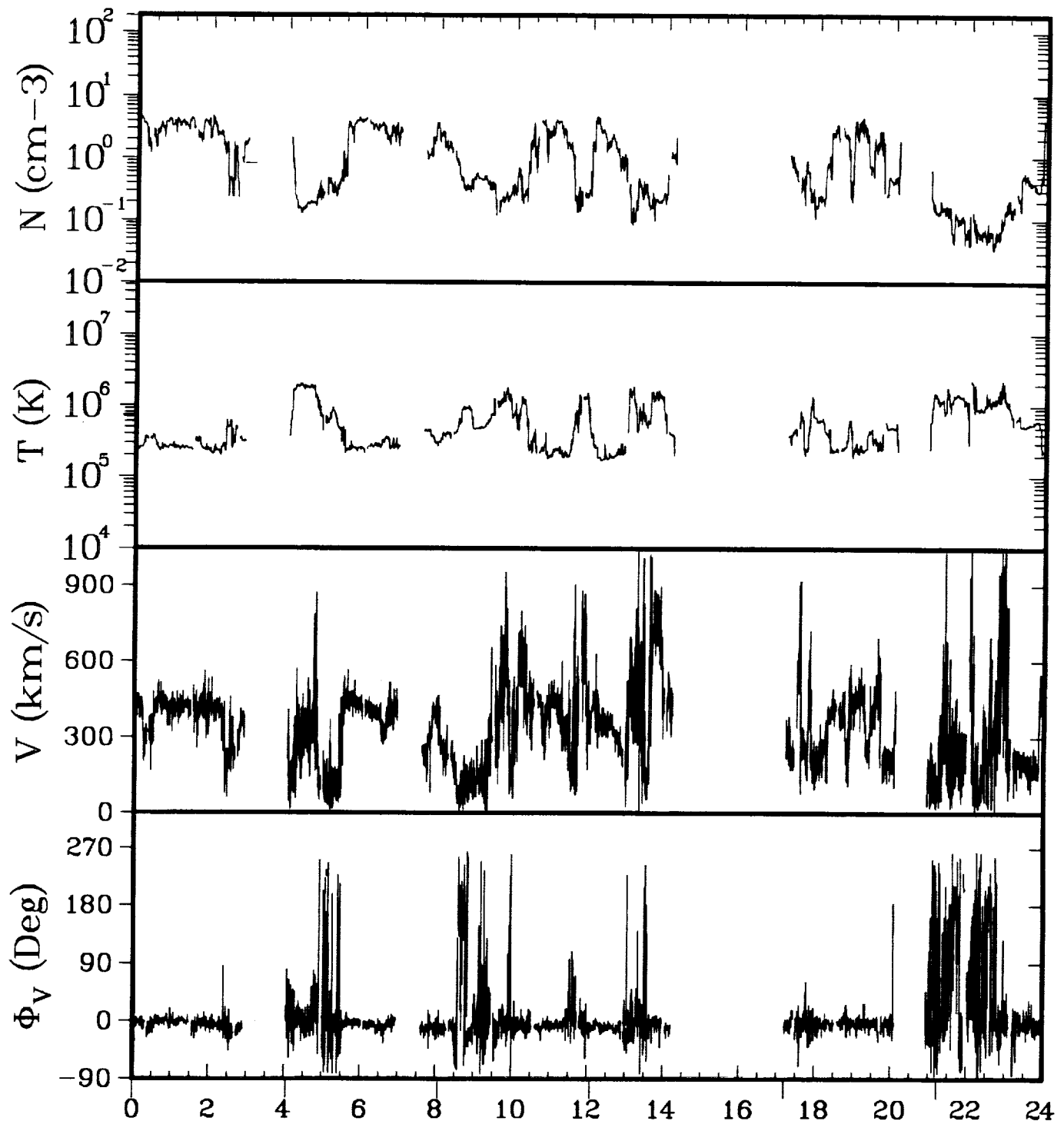

ISEE-3 ELECTRONS 07/07/83

GSEX	-235.7	-235.7	-235.7	-235.7	-235.6	-235.6
Y	9.9	10.0	10.1	10.2	10.3	10.4
Z	-9.7	-9.6	-9.4	-9.3	-9.1	-9.0
GSMY	10.8	9.2	7.1	6.7	9.6	11.3
Z	-8.7	-10.3	-11.8	-12.1	-9.9	-7.9

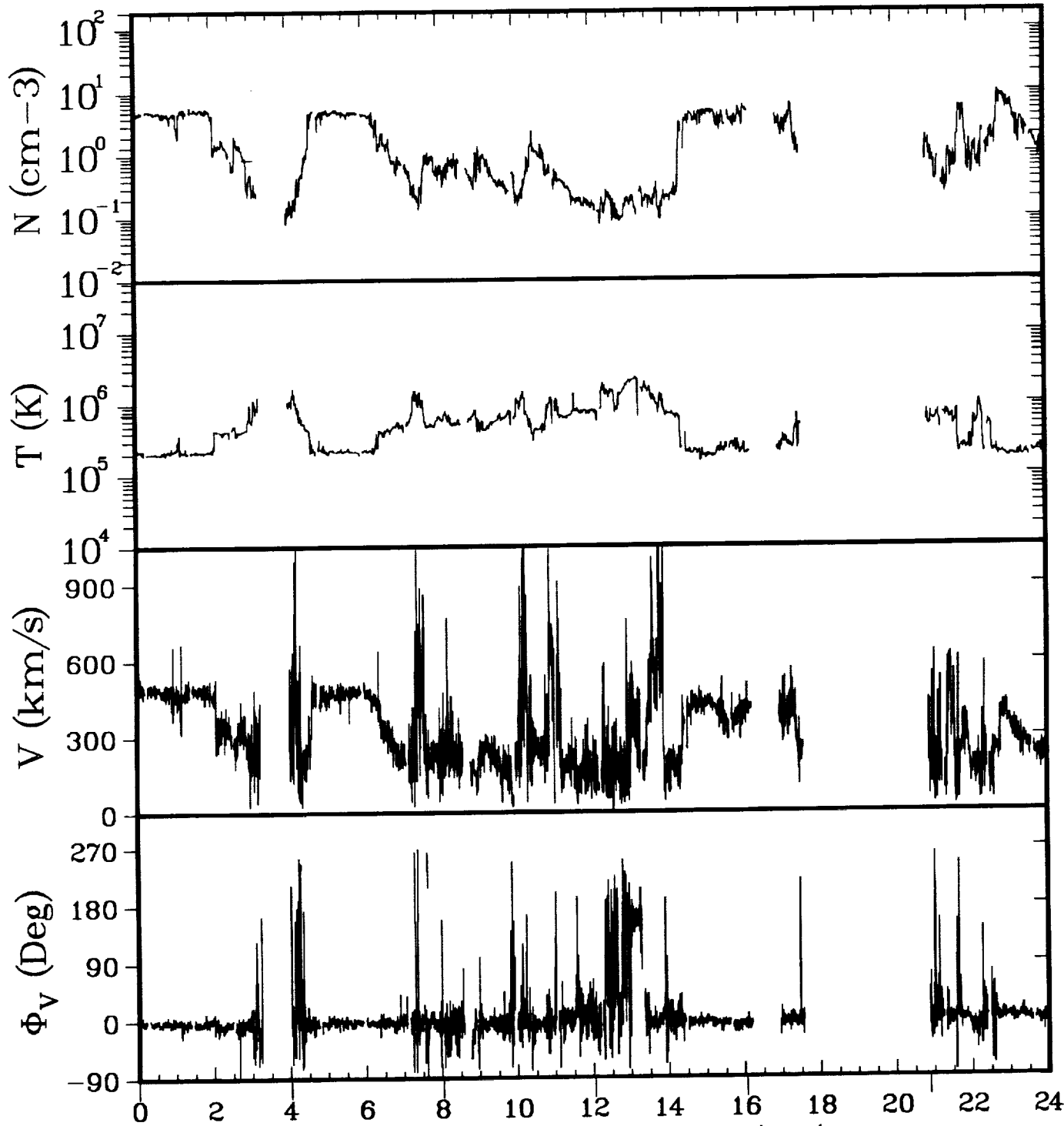

ISEE-3 ELECTRONS 07/08/83

GSEX	-235.6	-235.6	-235.5	-235.5	-235.5	-235.5
Y	10.5	10.6	10.7	10.8	10.9	11.0
Z	-8.9	-8.8	-8.7	-8.5	-8.4	-8.2
GSMY	11.2	9.8	7.9	7.4	9.4	11.7
Z	-7.9	-9.6	-11.3	-11.6	-10.0	-7.3

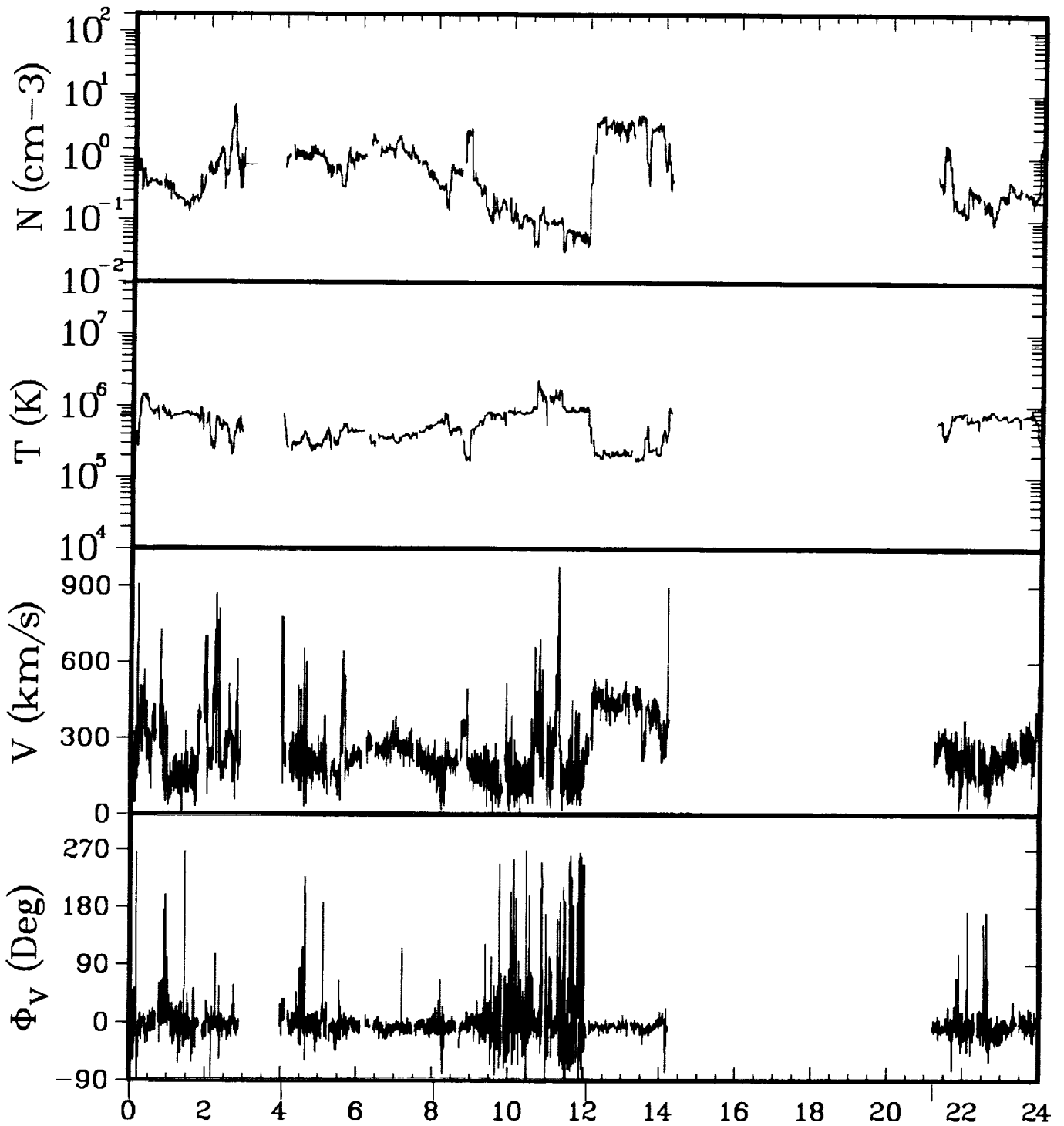

ISEE-3 ELECTRON 07/09/83

GSEX	-235.4	-235.4	-235.4	-235.4	-235.3
Y	11.1	11.2	11.3	11.4	11.6
Z	-8.1	-8.0	-7.9	-7.7	-7.4
GSMY	11.7	10.4	8.6	8.2	12.2
Z	-7.2	-8.9	-10.7	-11.1	-6.4

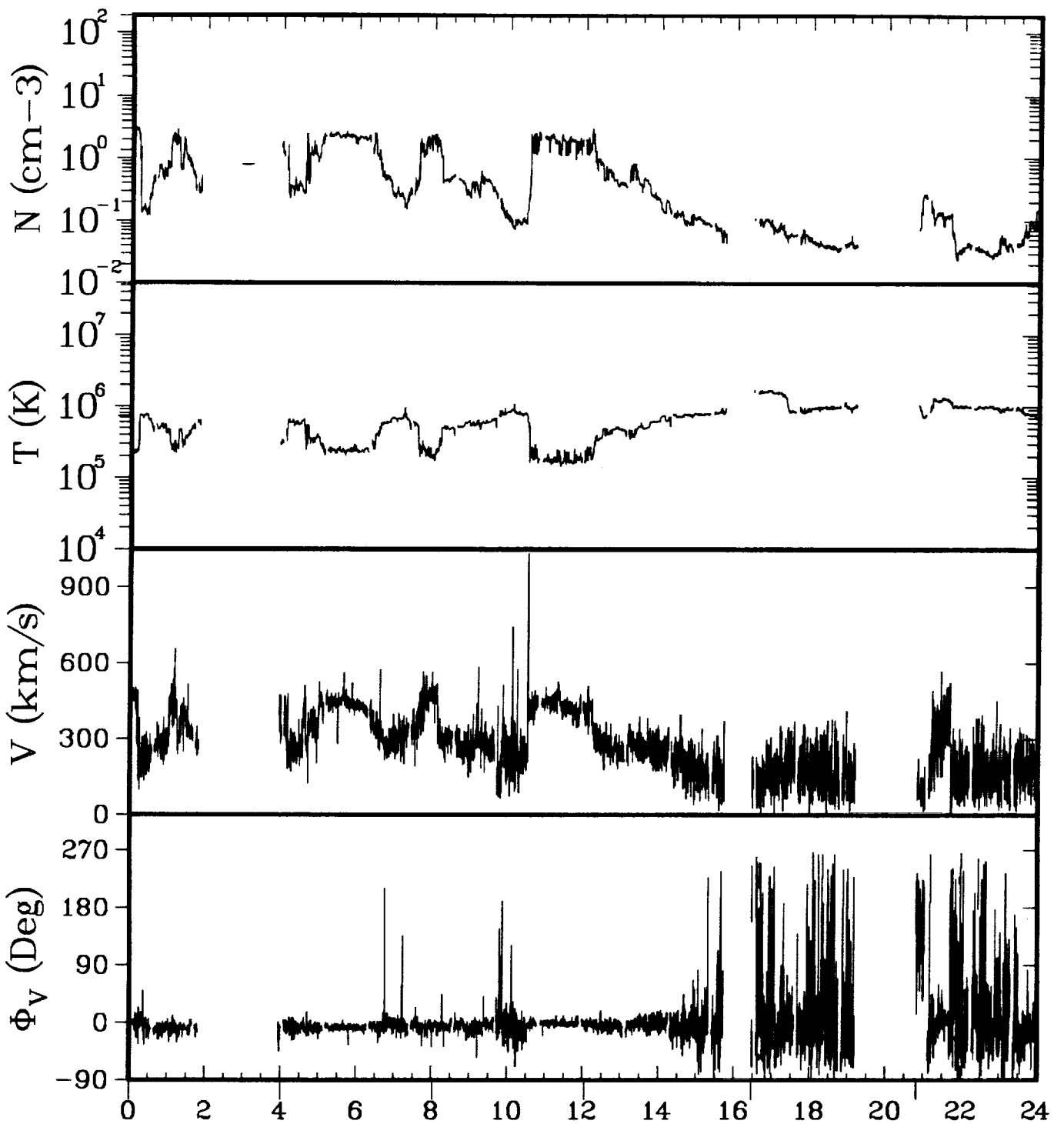

ISEE-3 ELECTRONS 07/10/83

GSEX	-235.3	-235.3	-235.3	-235.2	-235.2	-235.2
Y	11.7	11.8	11.9	12.0	12.1	12.2
Z	-7.4	-7.2	-7.1	-7.0	-6.8	-6.7
GSMY	12.2	11.1	9.3	8.9	11.0	12.6
Z	-6.4	-8.3	-10.2	-10.6	-8.5	-5.8

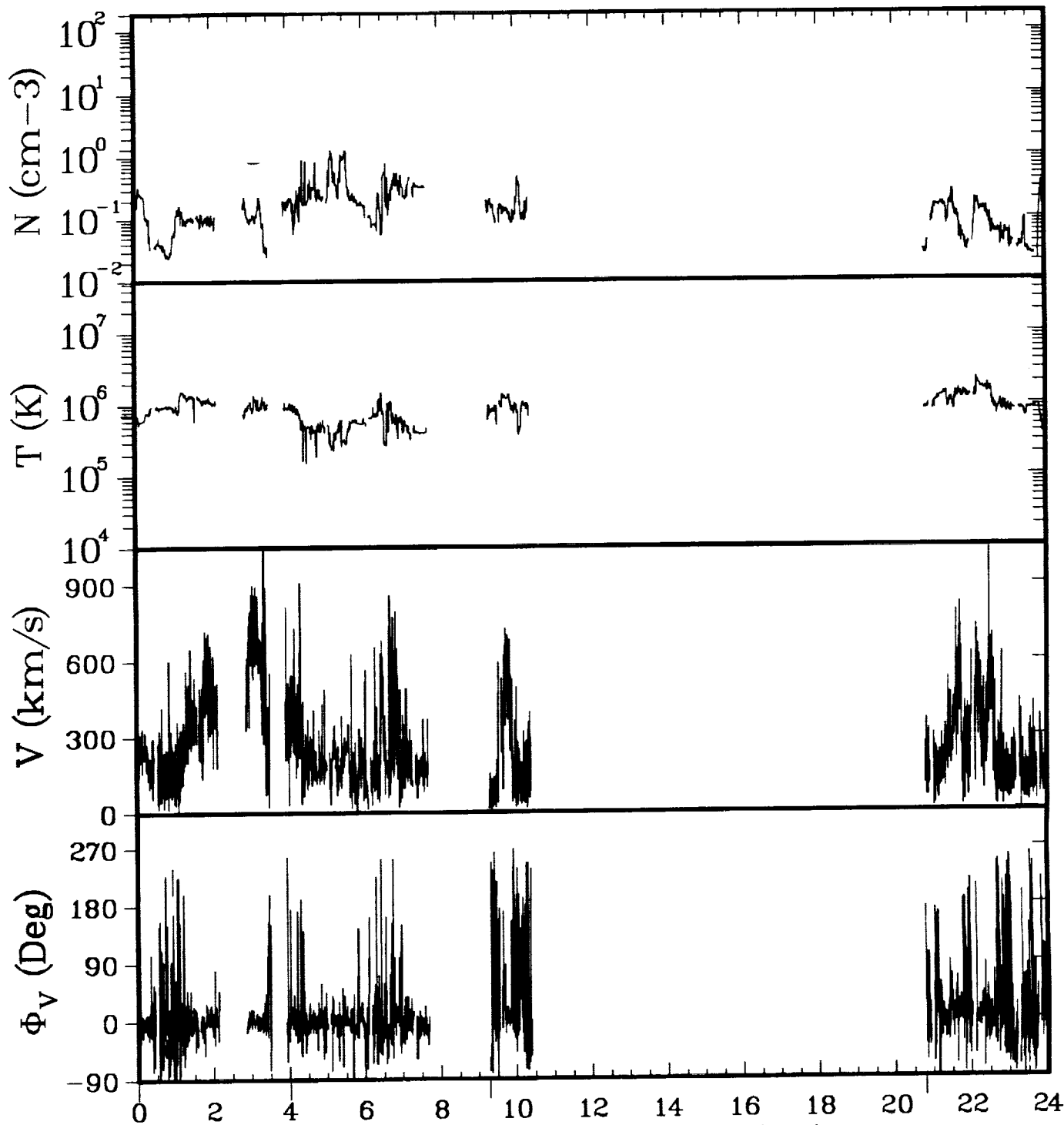

ISEE-3 ELECTRONS 07/11/83

GSEX	-235.2	-235.1	-235.1	-235.1
Y	12.3	12.4	12.5	12.8
Z	-6.6	-6.4	-6.2	-5.9
GSMY	12.7	11.7	9.7	13.1
Z	-5.7	-7.6	-10.0	-5.0

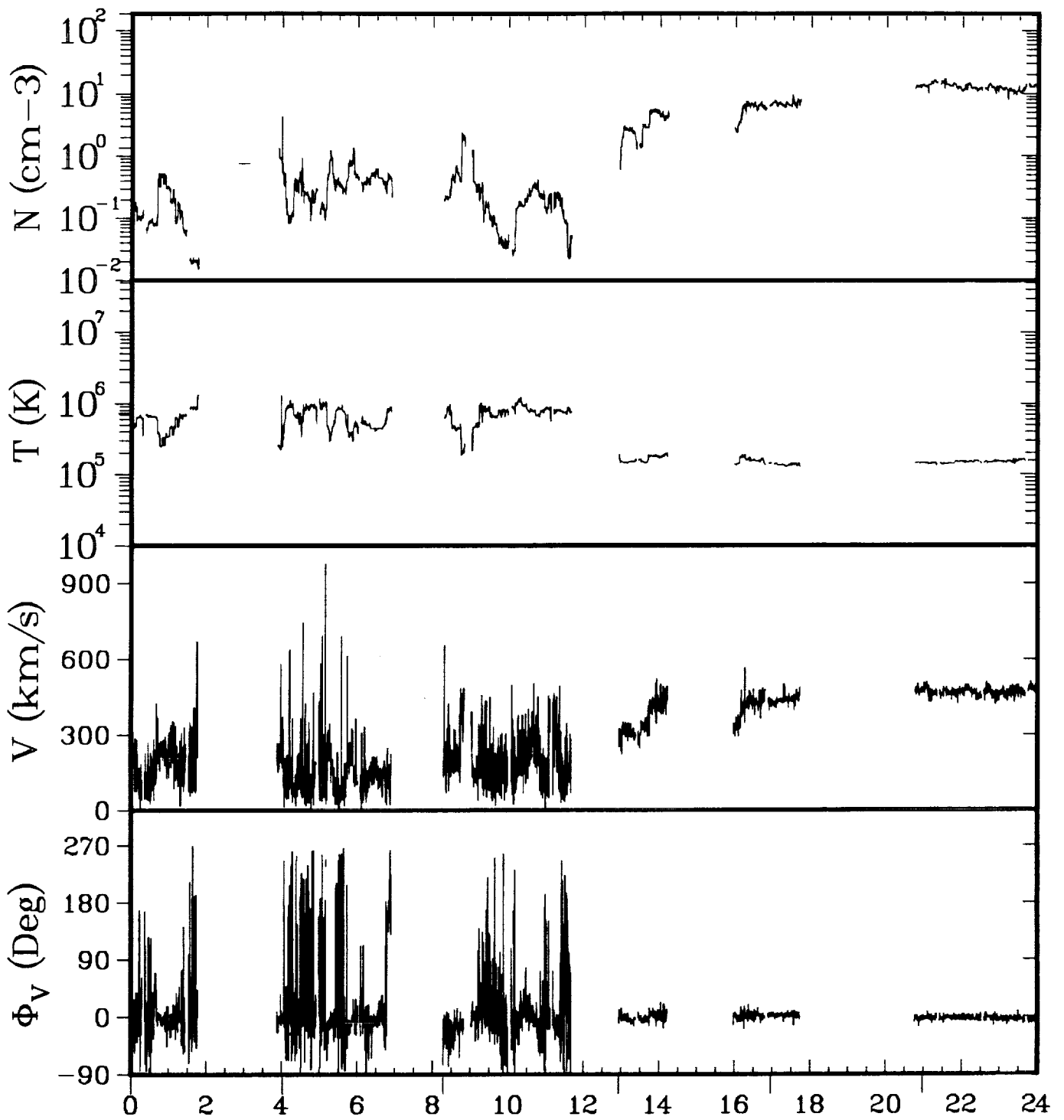

ISEE-3 ELECTRONS 07/12/83

GSEX	-235.0	-235.0	-235.0	-235.0	-235.0	-235.0
Y	12.8	12.9	13.0	13.1	13.2	13.3
Z	-5.8	-5.6	-5.5	-5.3	-5.2	-5.1
GSMY	13.2	12.3	10.7	10.6	12.4	13.6
Z	-4.9	-7.0	-9.2	-9.4	-6.8	-4.2

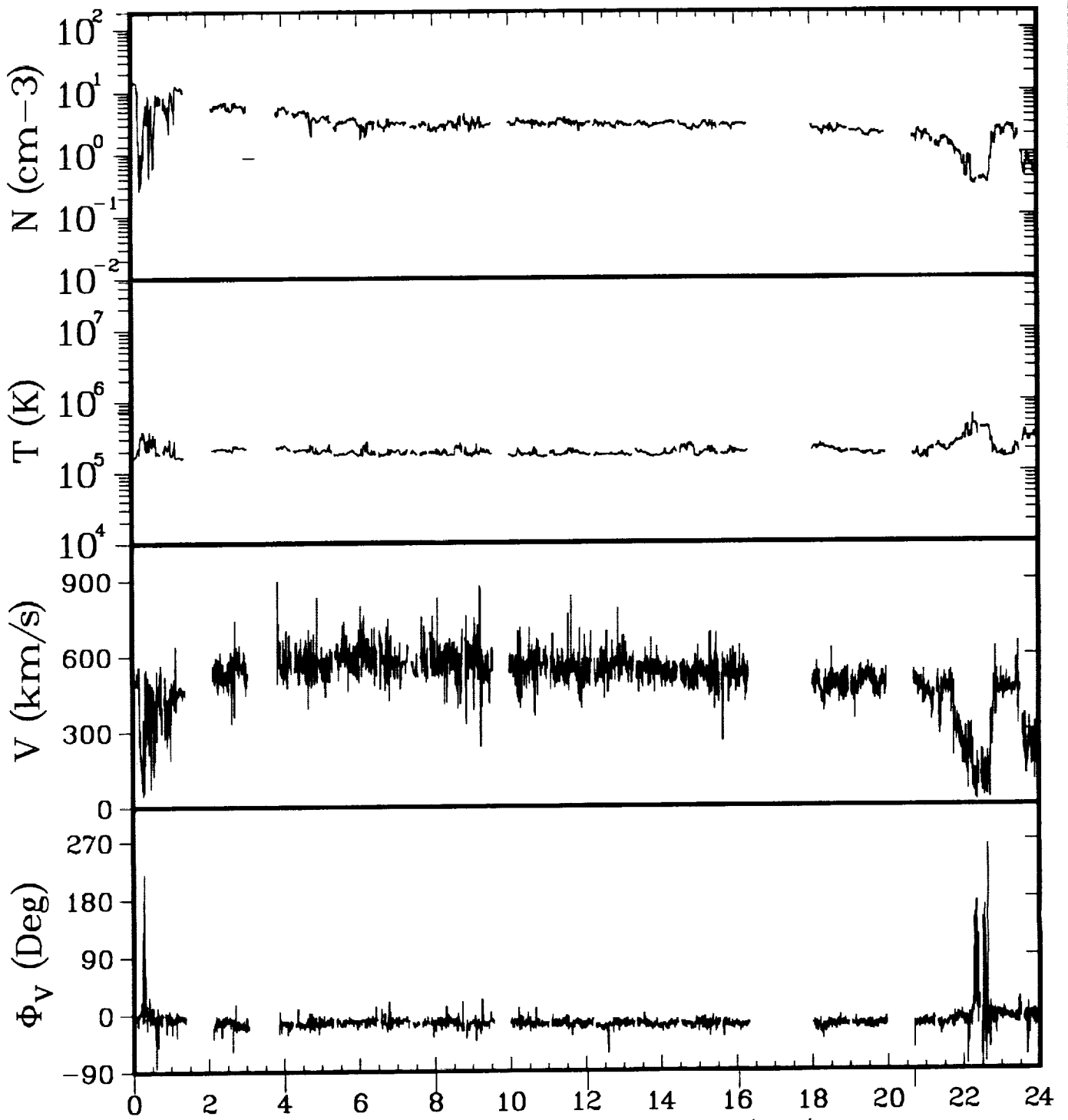

ISEE-3 ELECTRONS 07/13/83

GSEX	-234.9	-234.9	-234.9	-234.9	-234.9	-234.9
Y	13.4	13.5	13.5	13.6	13.7	13.8
Z	-5.0	-4.8	-4.7	-4.5	-4.4	-4.3
GSMY	13.6	12.8	11.5	11.1	12.6	14.0
Z	-4.2	-6.3	-8.6	-9.1	-7.0	-3.6

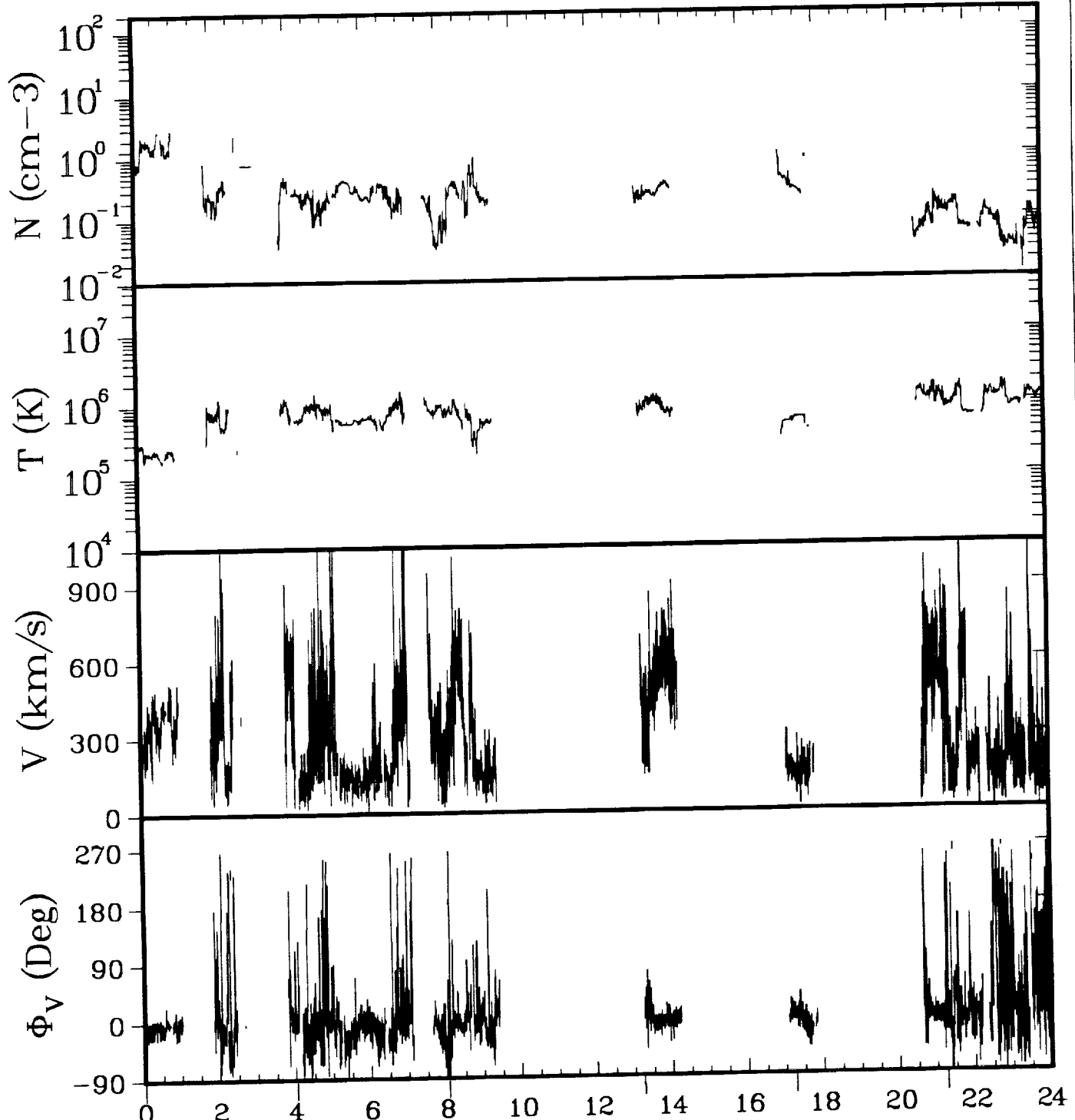

ISEE-3 ELECTRONS 07/14/83

GSEX	-234.8	-234.8	-234.8	-234.8	-234.8	-234.7
Y	13.9	14.0	14.0	14.1	14.2	14.3
Z	-4.1	-4.0	-3.9	-3.7	-3.6	-3.4
GSMY	14.1	13.4	12.1	12.1	13.7	14.4
Z	-3.5	-5.6	-8.1	-8.2	-5.3	-2.7

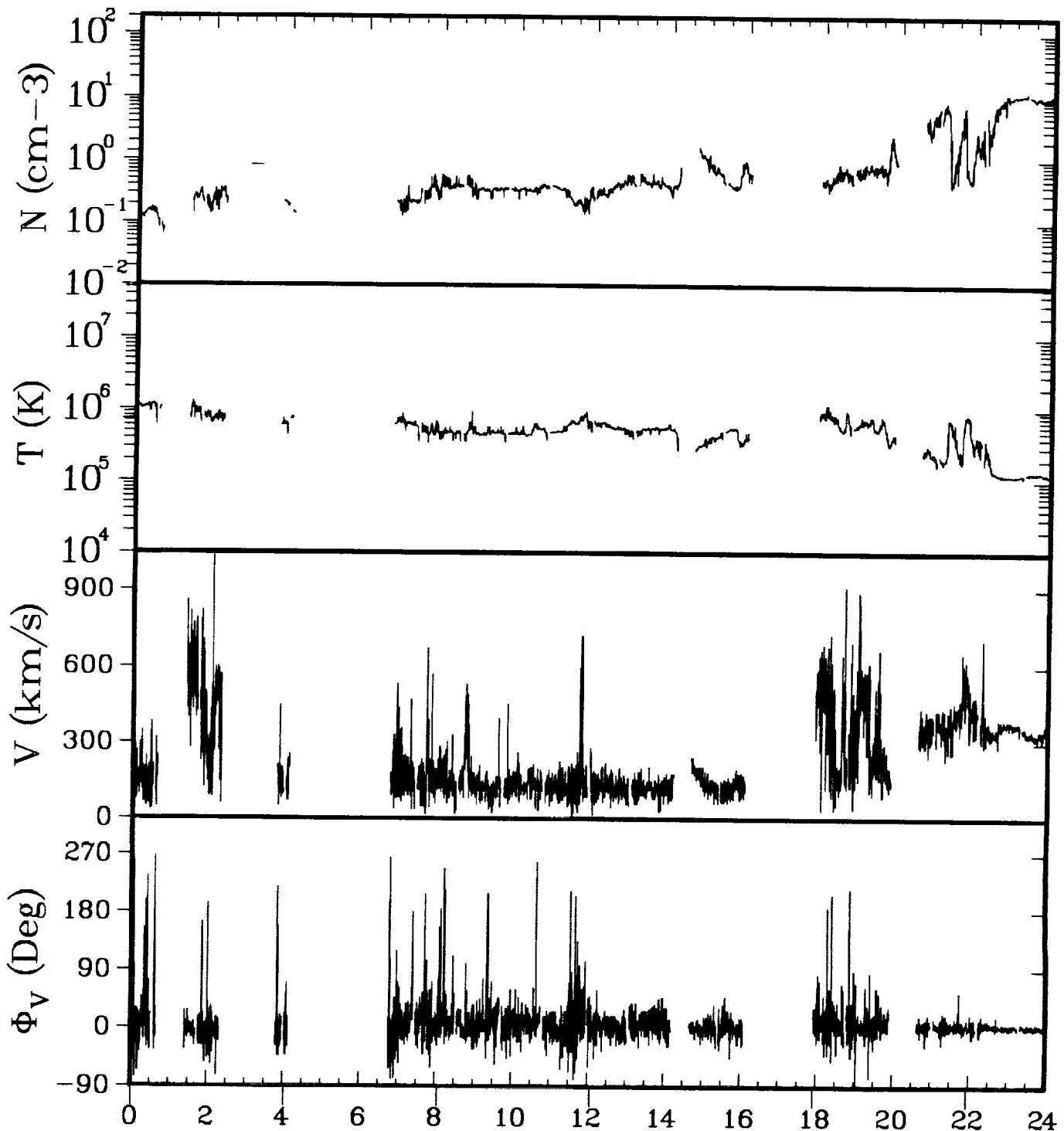

ISEE-3 ELECTRONS 07/15/83

GSEX	-234.7	-234.7	-234.7	-234.7	-234.7	-234.6
Y	14.3	14.4	14.5	14.5	14.6	14.7
Z	-3.3	-3.2	-3.1	-2.9	-2.7	-2.6
GSMY	14.5	13.9	12.7	12.4	14.3	14.8
Z	-2.7	-5.0	-7.5	-8.1	-4.0	-1.8

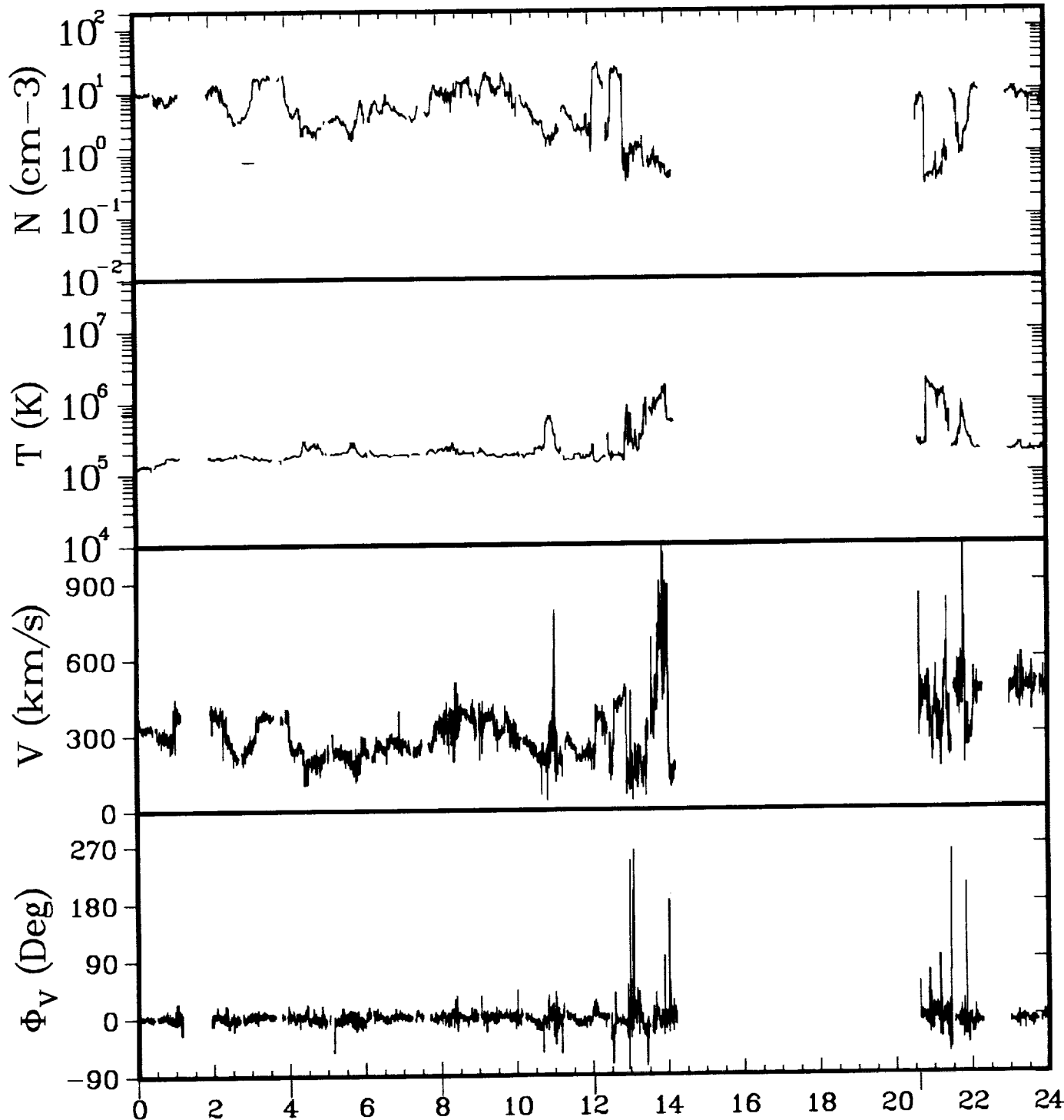

ISEE-3 ELECTRONS 07/16/83

GSEX	-234.6	-234.6	-234.6	-234.6	-234.5
Y	14.7	14.8	14.8	14.9	15.0
Z	-2.5	-2.4	-2.3	-2.1	-1.8
GSMY	14.8	14.4	13.3	13.0	15.1
Z	-2.0	-4.3	-7.0	-7.6	-1.5

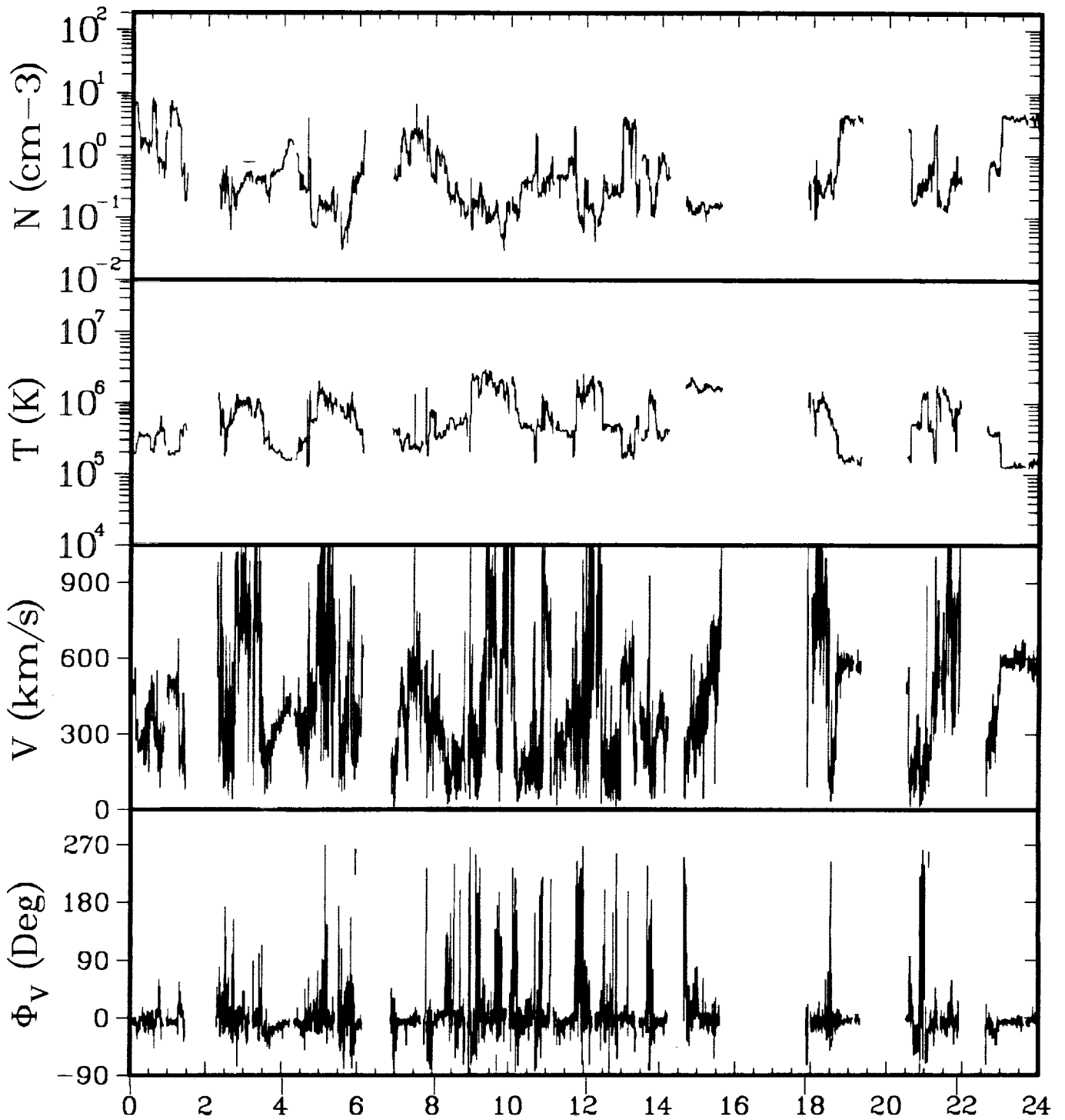

ISEE-3 ELECTRONS 07/17/83

GSEX	-234.5	-234.5	-234.4	-234.4	-234.4	-234.4
Y	15.1	15.1	15.2	15.2	15.3	15.3
Z	-1.7	-1.6	-1.4	-1.3	-1.1	-1.0
GSMY	15.1	14.8	13.8	13.6	15.1	15.4
Z	-1.3	-3.7	-6.4	-7.0	-2.7	-0.4

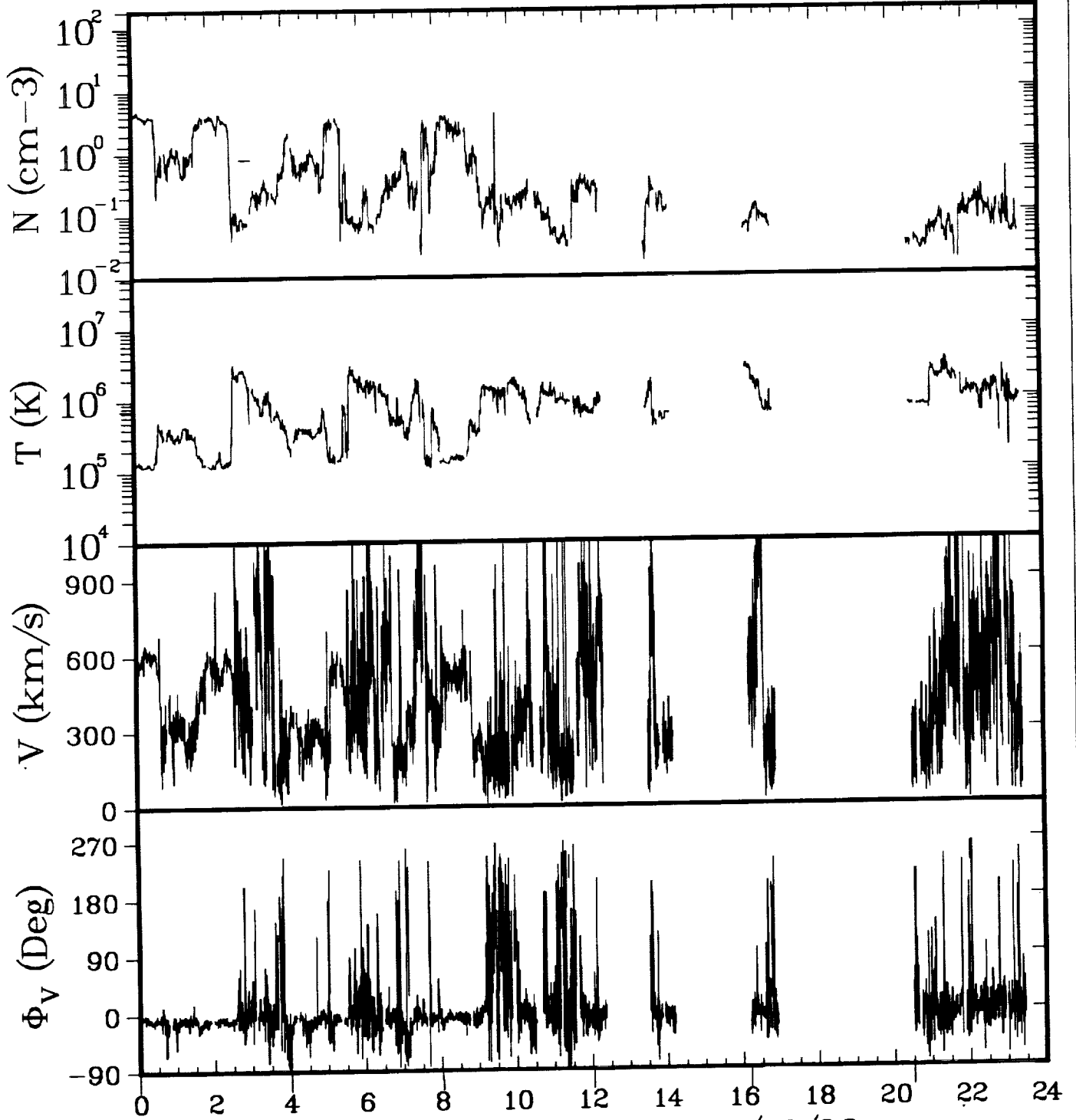

ISEE-3 ELECTRONS 07/18/83

GSEX	-234.3	-234.3	-234.3	-234.2	-234.2	-234.2
Y	15.4	15.4	15.4	15.5	15.5	15.6
Z	-0.9	-0.8	-0.6	-0.5	-0.4	-0.2
GSMY	15.4	15.1	14.3	14.1	15.1	15.6
Z	-0.6	-3.0	-5.8	-6.4	-3.7	-0.1

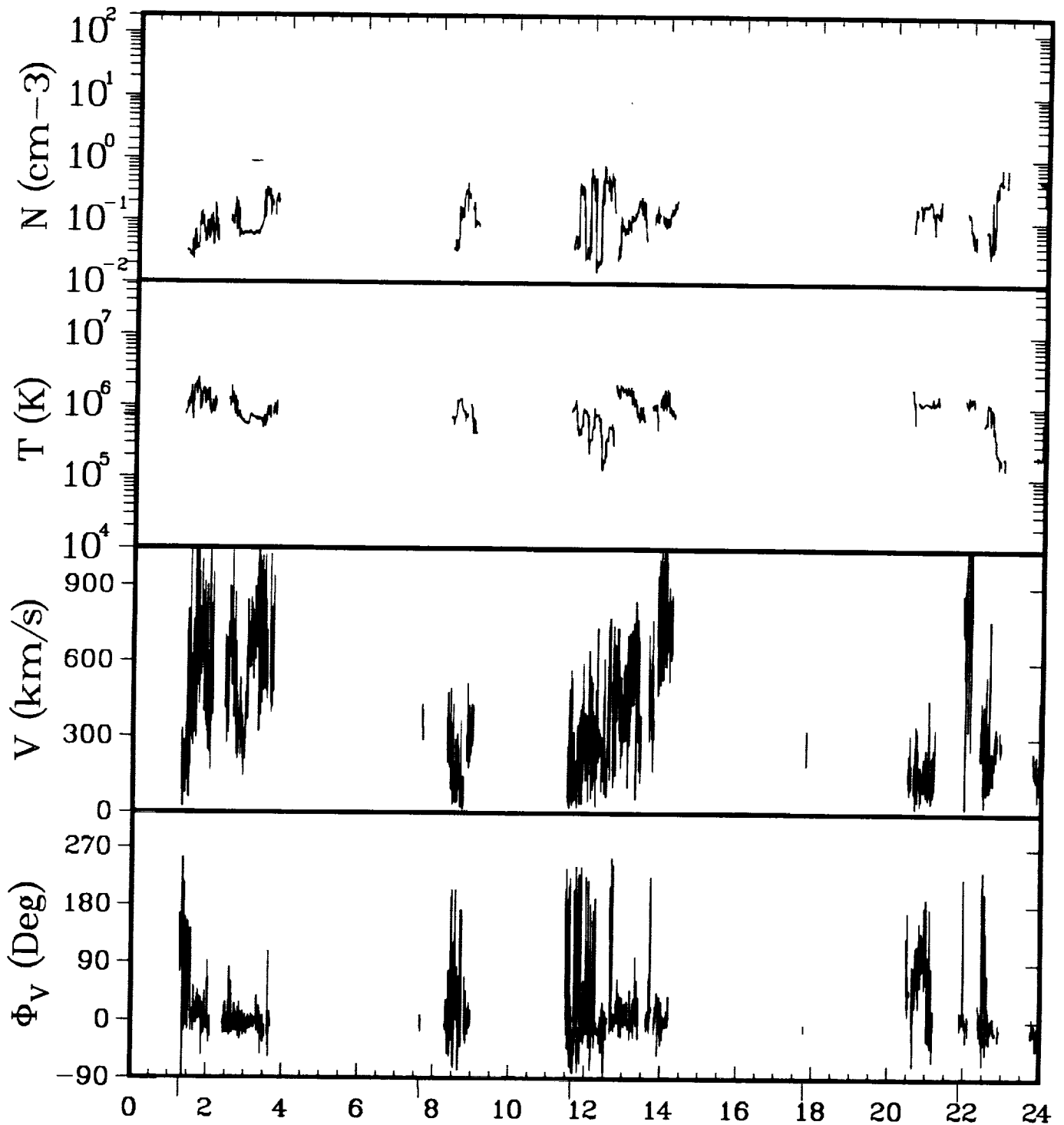

ISEE-3 ELECTRONS 07/19/83

GSEX	-234.1	-234.1	-234.0	-234.0	-233.9
Y	15.6	15.6	15.7	15.7	15.7
Z	-0.1	0.1	0.3	0.5	0.6
GSMY	15.6	14.8	14.5	15.7	15.7
Z	-0.4	-5.0	-6.0	-1.5	1.0

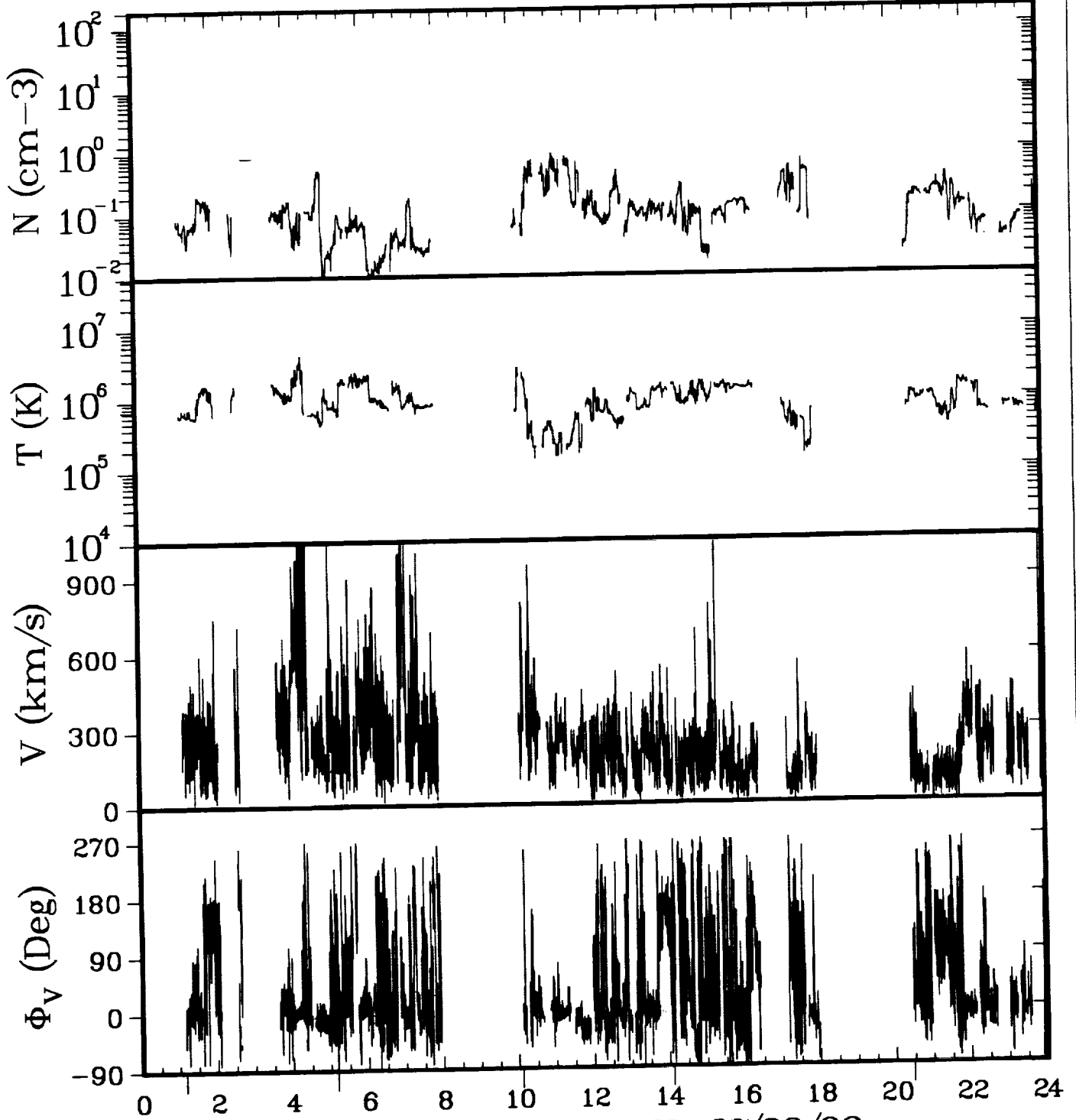

ISEE-3 ELECTRONS 07/20/83

GSEX	-233.9	-233.9	-233.8	-233.8	-233.7
Y	15.8	15.8	15.8	15.8	15.9
Z	0.7	0.9	1.0	1.2	1.4
GSMY	15.8	15.6	14.9	15.3	15.9
Z	0.4	-2.6	-5.4	-4.3	1.3

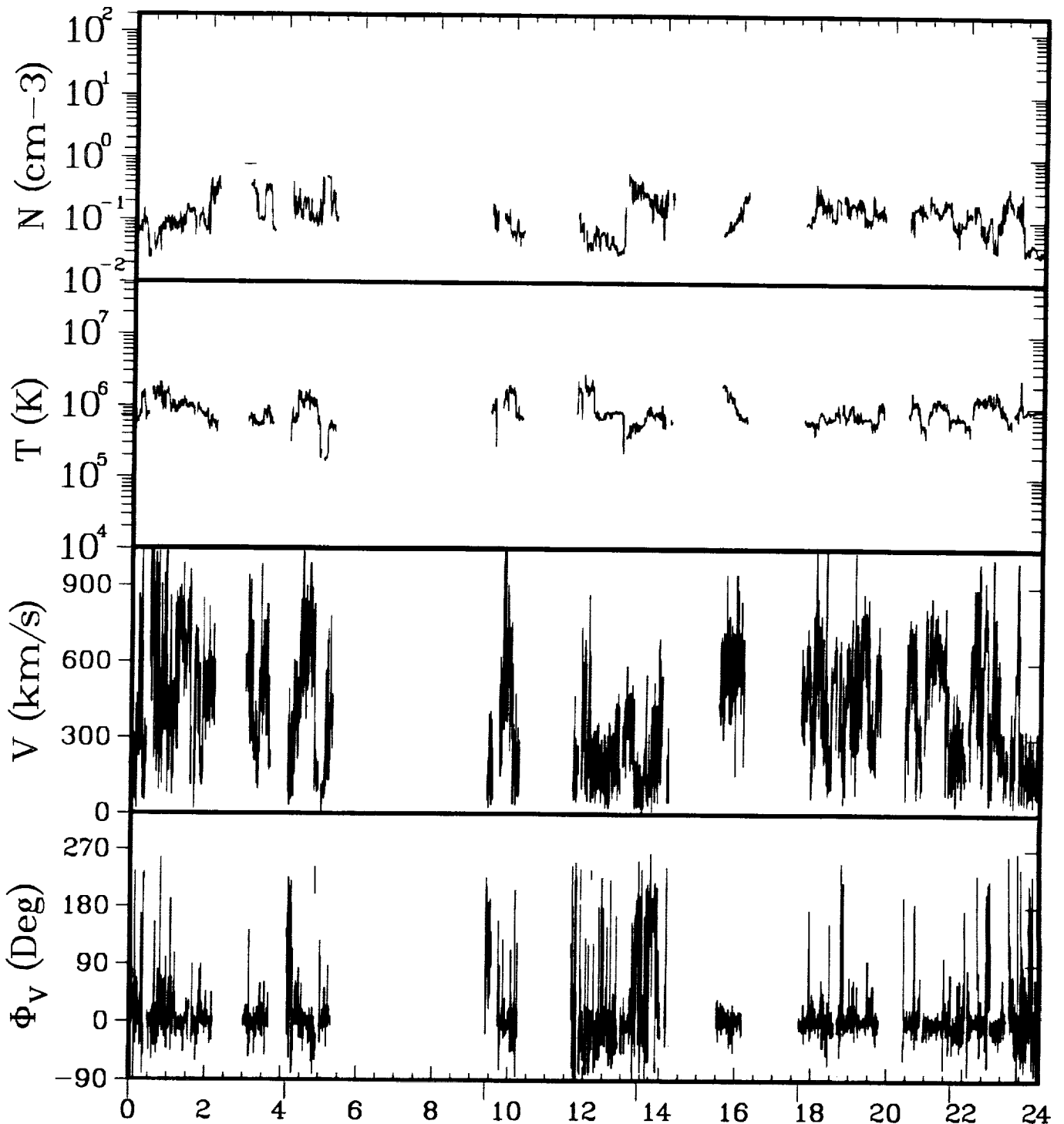

ISEE-3 ELECTRONS 07/21/83

GSEX	-233.7	-233.6	-233.5	-233.5	-233.4	-233.4
Y	15.9	15.9	15.9	15.9	15.9	16.0
Z	1.5	1.6	1.8	1.9	2.1	2.2
GSMY	15.9	16.0	15.4	15.5	16.1	15.9
Z	1.6	-1.1	-4.6	-4.1	-0.2	2.4

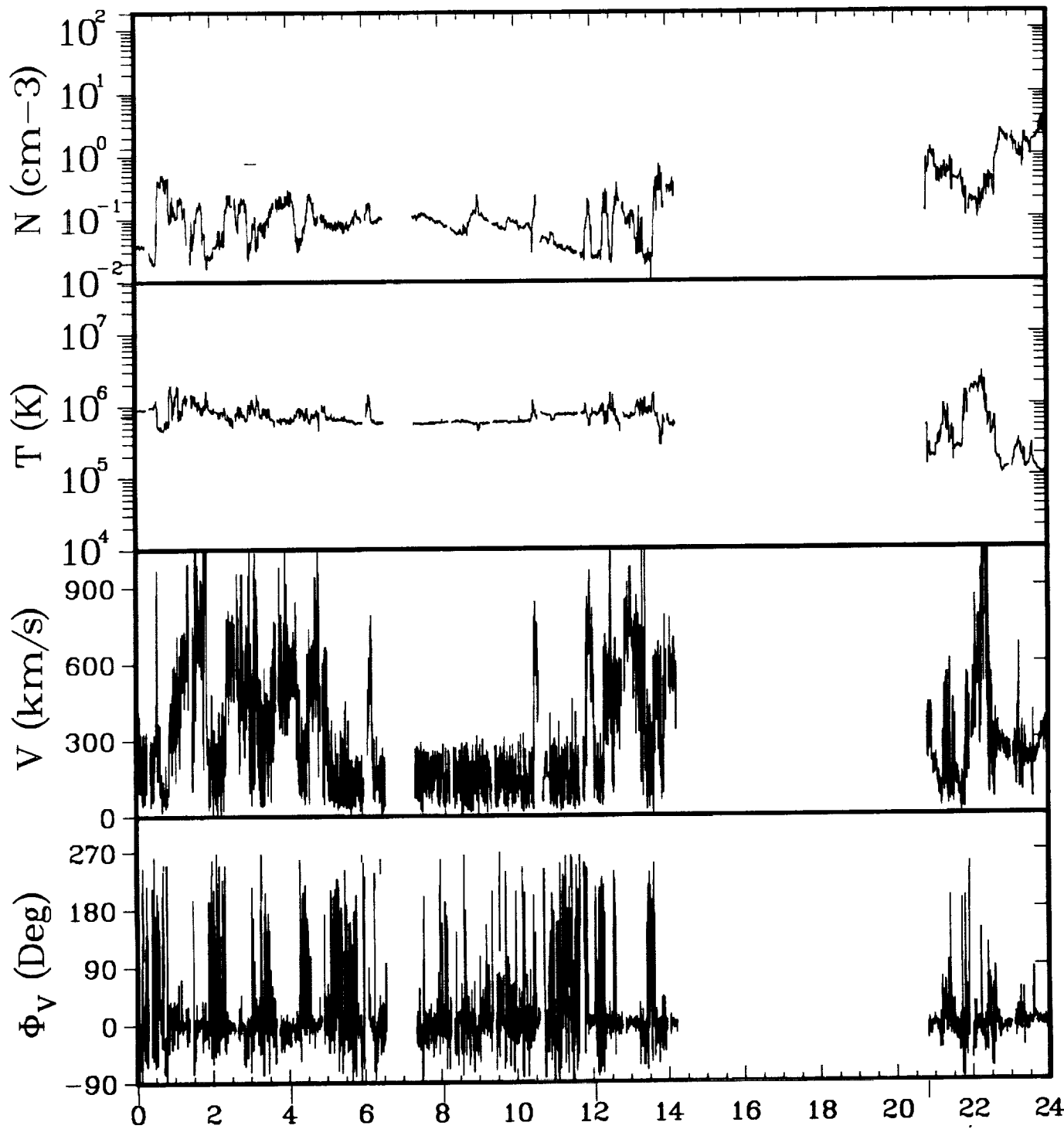

ISEE-3 ELECTRONS 07/22/83

GSEX	-233.3	-233.3	-233.2	-233.2	-233.0
Y	16.0	16.0	16.0	16.0	16.0
Z	2.3	2.4	2.6	2.7	3.0
GSMY	16.0	16.2	15.8	15.7	16.0
Z	2.2	-0.3	-3.4	-4.0	2.8

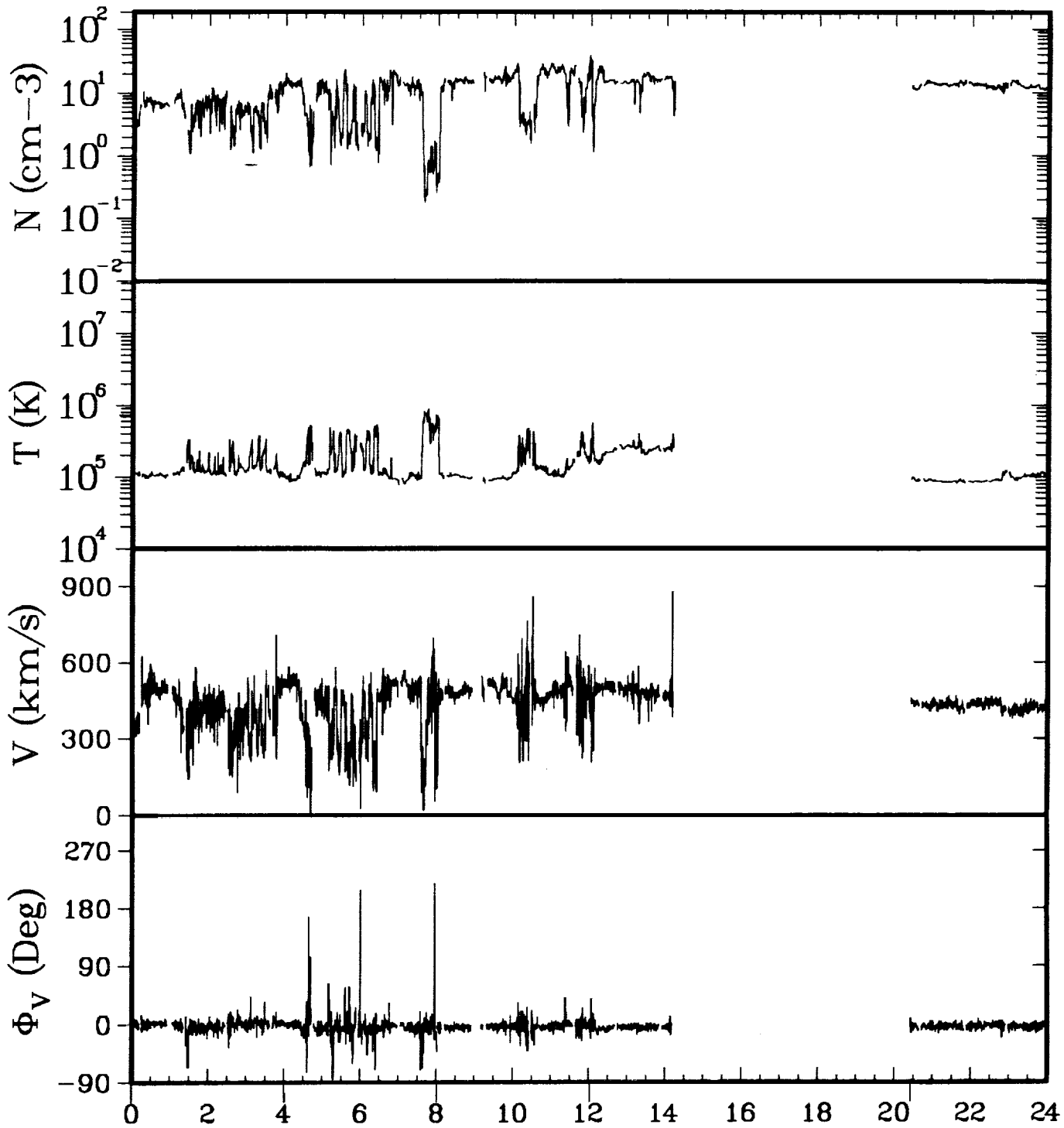

ISEE-3 ELECTRONS 07/23/83

GSEX	-233.0	-232.9	-232.8	-232.8	-232.6
Y	16.0	16.0	16.0	16.0	16.0
Z	3.1	3.2	3.4	3.5	3.8
GSMY	16.0	16.3	16.1	16.0	16.1
Z	2.9	0.4	-2.7	-3.4	3.3

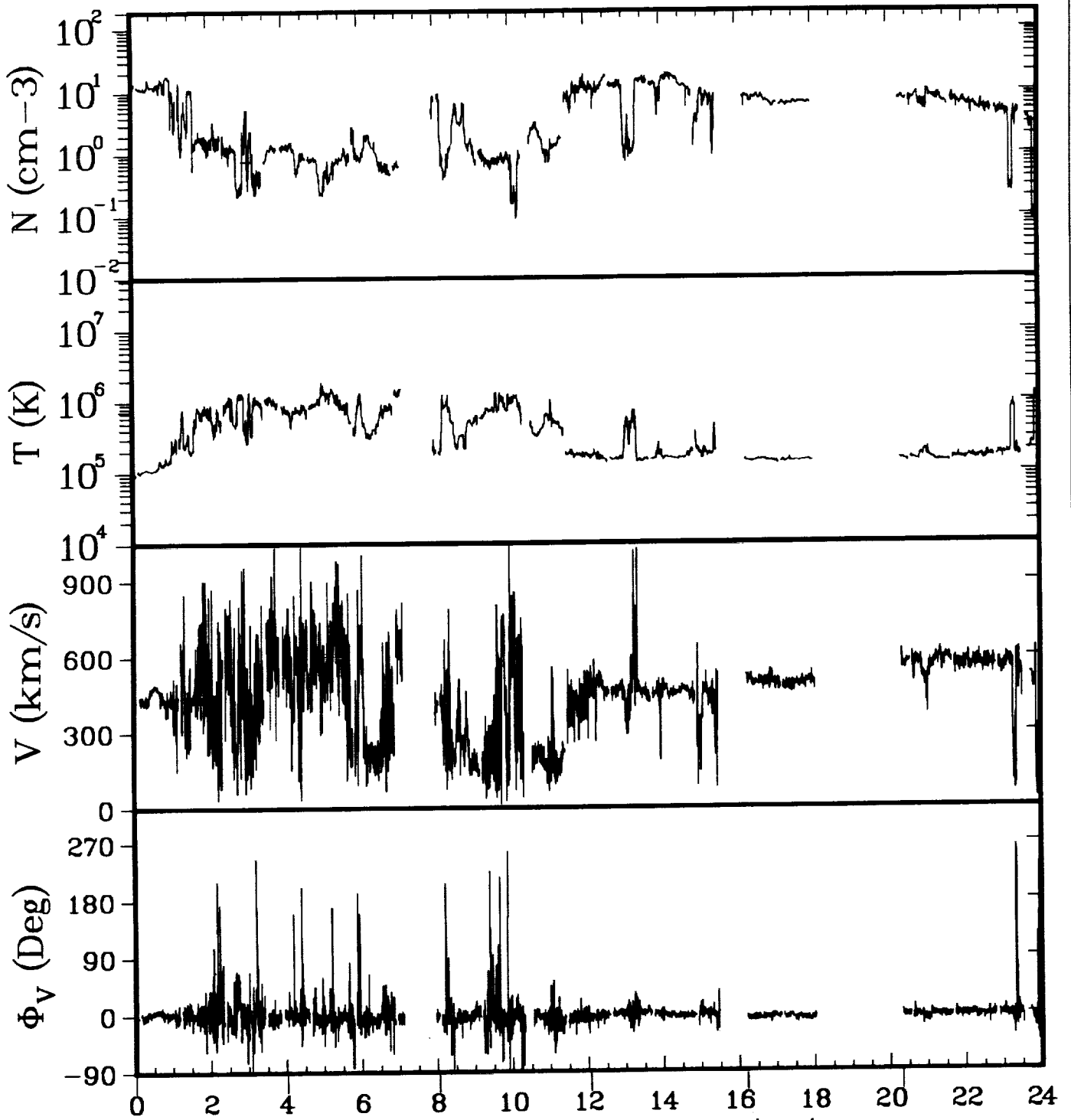

ISEE-3 ELECTRONS 07/24/83

GSEX	-232.6	-232.5	-232.4	-232.3	-232.2	-232.2
Y	16.0	16.0	16.0	16.0	16.0	15.9
Z	3.9	4.0	4.2	4.3	4.4	4.6
GSMY	16.0	16.4	16.4	16.3	16.6	16.1
Z	3.6	1.1	-2.1	-2.8	0.3	4.0

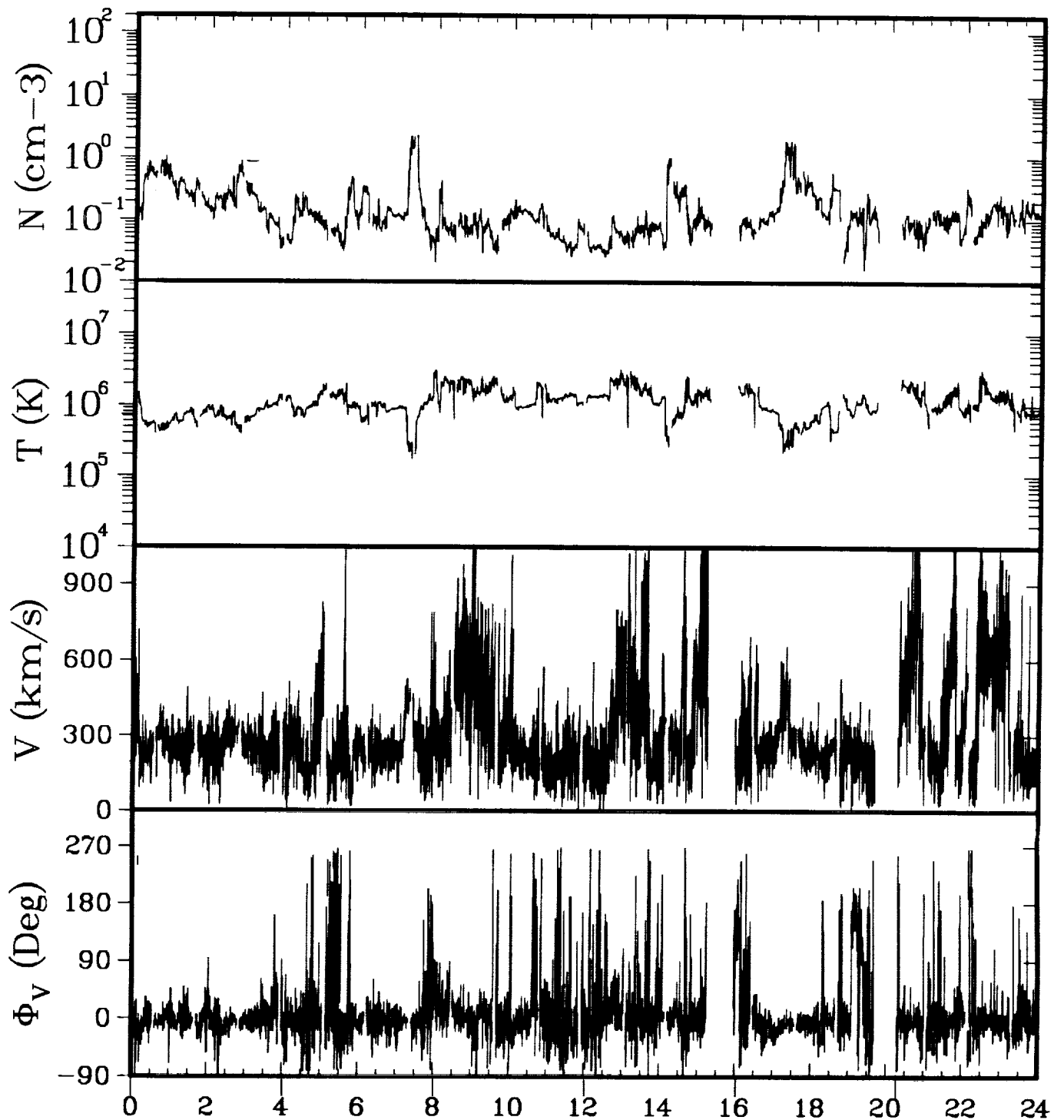

ISEE-3 ELECTRONS 07/25/83

GSEX	-232.1	-232.0	-231.9	-231.8	-231.7	-231.6
Y	15.9	15.9	15.9	15.9	15.9	15.9
Z	4.7	4.8	4.9	5.1	5.2	5.3
GSMY	16.0	16.5	16.6	16.6	16.7	16.1
Z	4.3	1.8	-1.4	-2.1	0.8	4.7

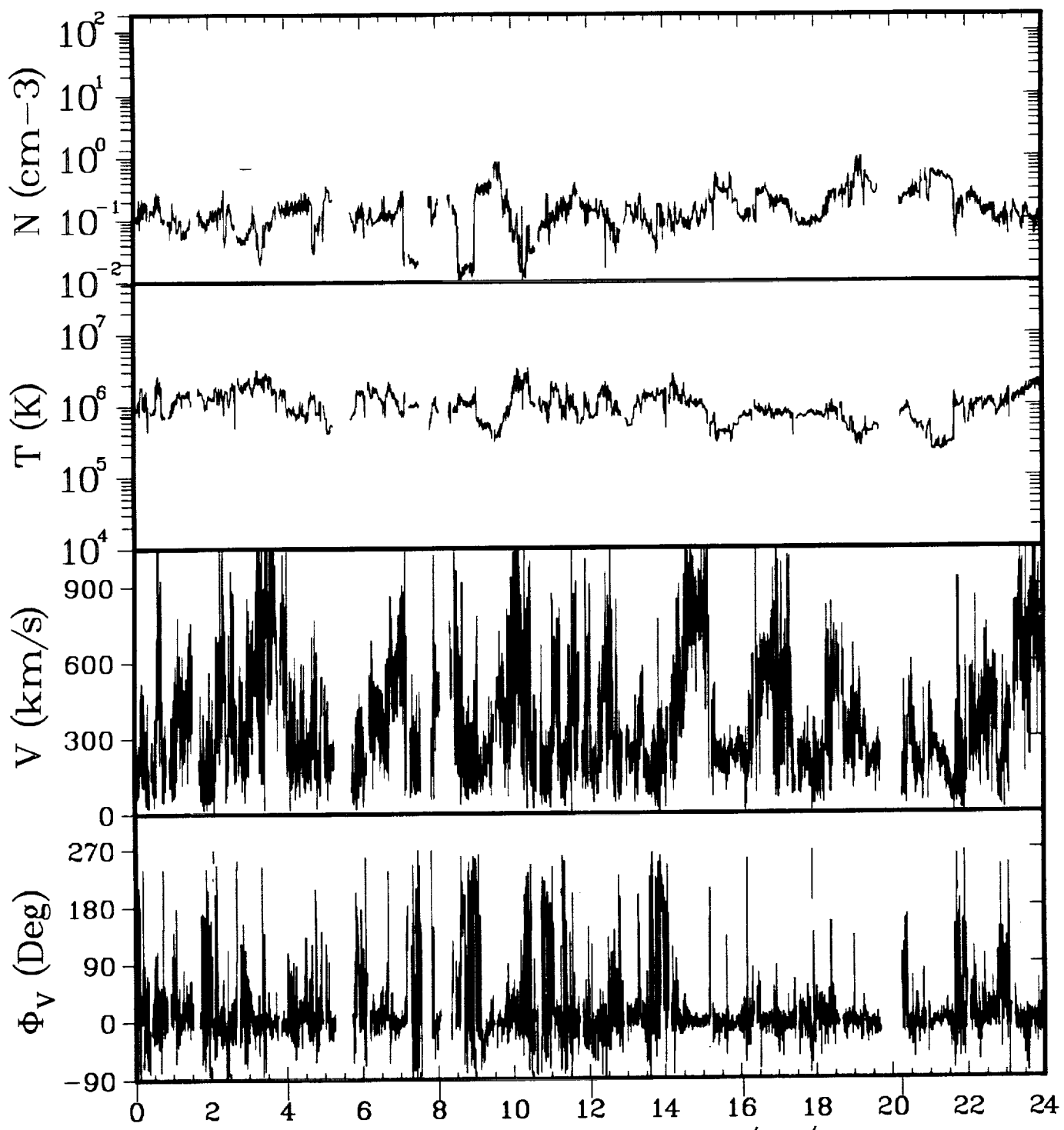

ISEE-3 ELECTRONS 07/26/83

GSEX	-231.5	-231.5	-231.4	-231.3	-231.2	-231.1
Y	15.9	15.8	15.8	15.8	15.8	15.8
Z	5.5	5.6	5.7	5.9	6.0	6.1
GSMY	16.0	16.6	16.8	16.8	16.8	16.1
Z	5.0	2.5	-0.7	-1.5	1.5	5.3

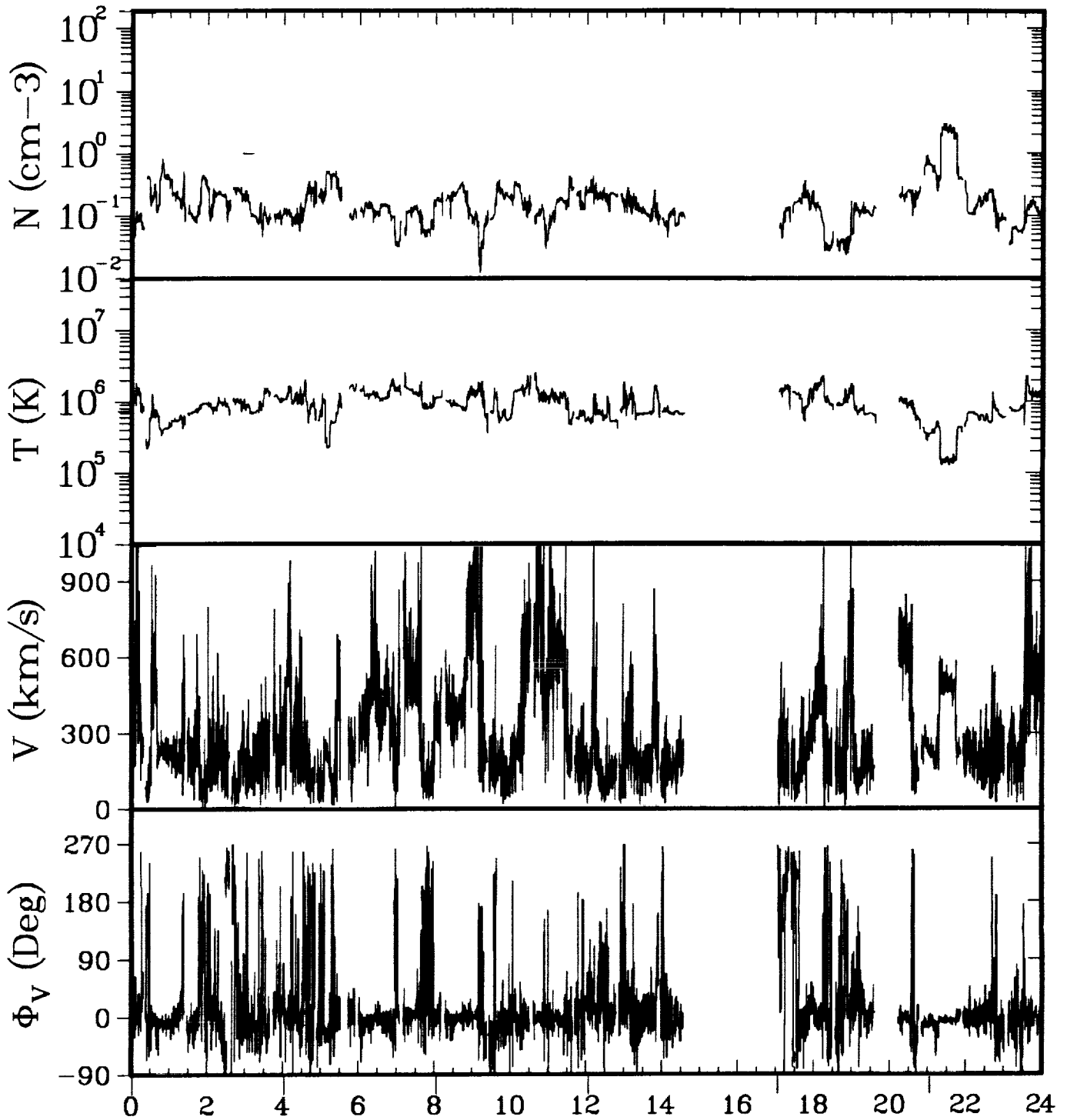

ISEE-3 ELECTRONS 07/27/83

GSEX	-231.0	-230.9	-230.8	-230.6	-230.5	-230.4
Y	15.8	15.7	15.7	15.7	15.7	15.7
Z	6.2	6.4	6.5	6.6	6.8	6.9
GSMY	16.0	16.7	17.0	17.0	16.8	15.9
Z	5.7	3.1	-0.1	-0.8	3.3	6.4

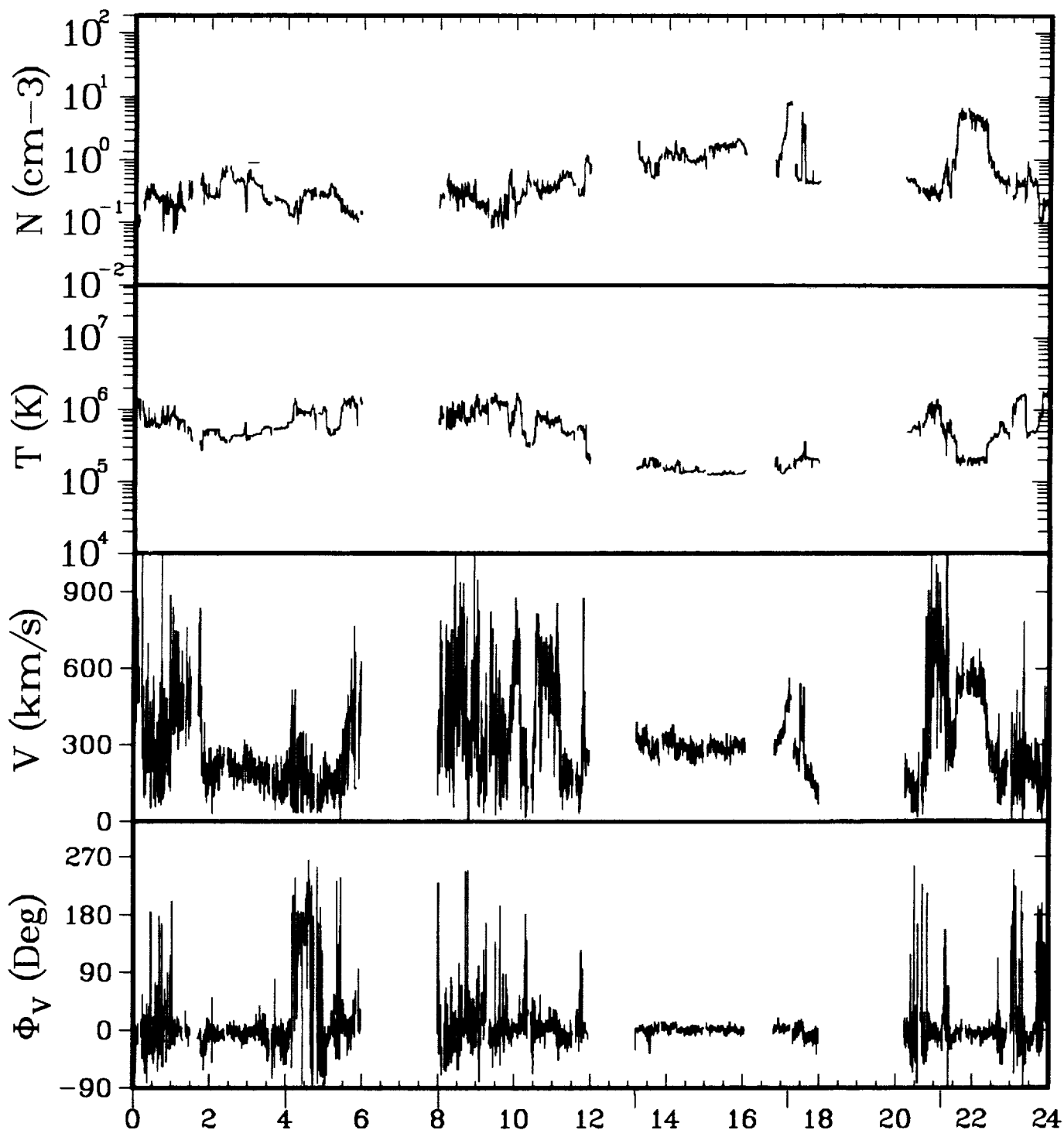

ISEE-3 ELECTRONS 07/28/83

GSEX	-230.3	-230.2	-230.1	-229.9	-229.8	-229.7
Y	15.6	15.6	15.6	15.6	15.5	15.5
Z	7.0	7.2	7.3	7.4	7.6	7.7
GSMY	15.9	16.7	17.2	17.2	16.8	15.8
Z	6.4	3.9	0.6	0.4	4.1	7.1

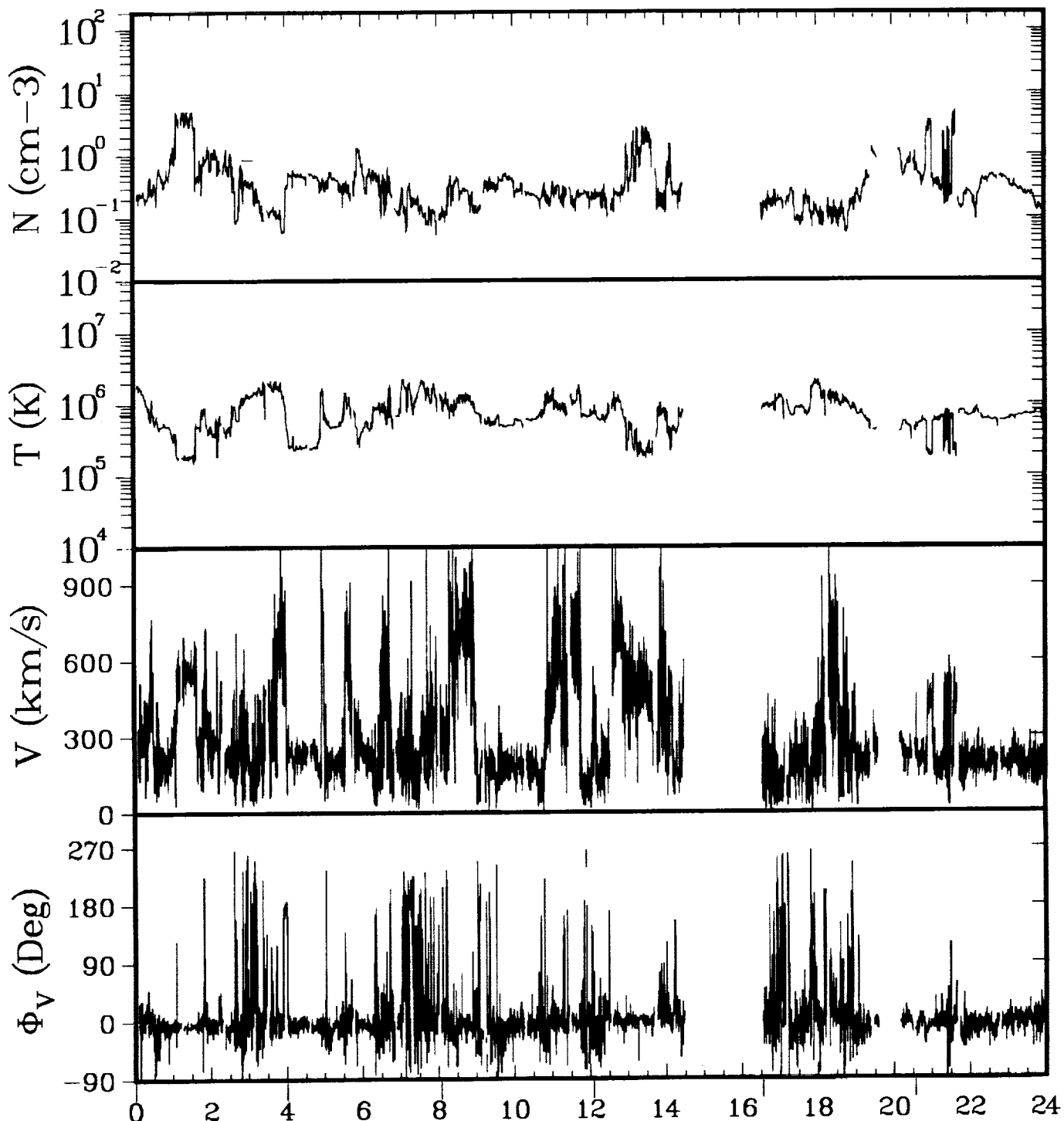

ISEE-3 ELECTRONS 07/29/83

GSEX	-229.6	-229.5	-229.4	-229.3	-229.1	-229.0
Y	15.5	15.5	15.4	15.4	15.4	15.4
Z	7.8	7.9	8.1	8.2	8.3	8.4
GSMY	15.8	16.8	17.4	17.4	17.0	15.8
Z	7.1	4.5	1.2	0.5	4.1	7.5

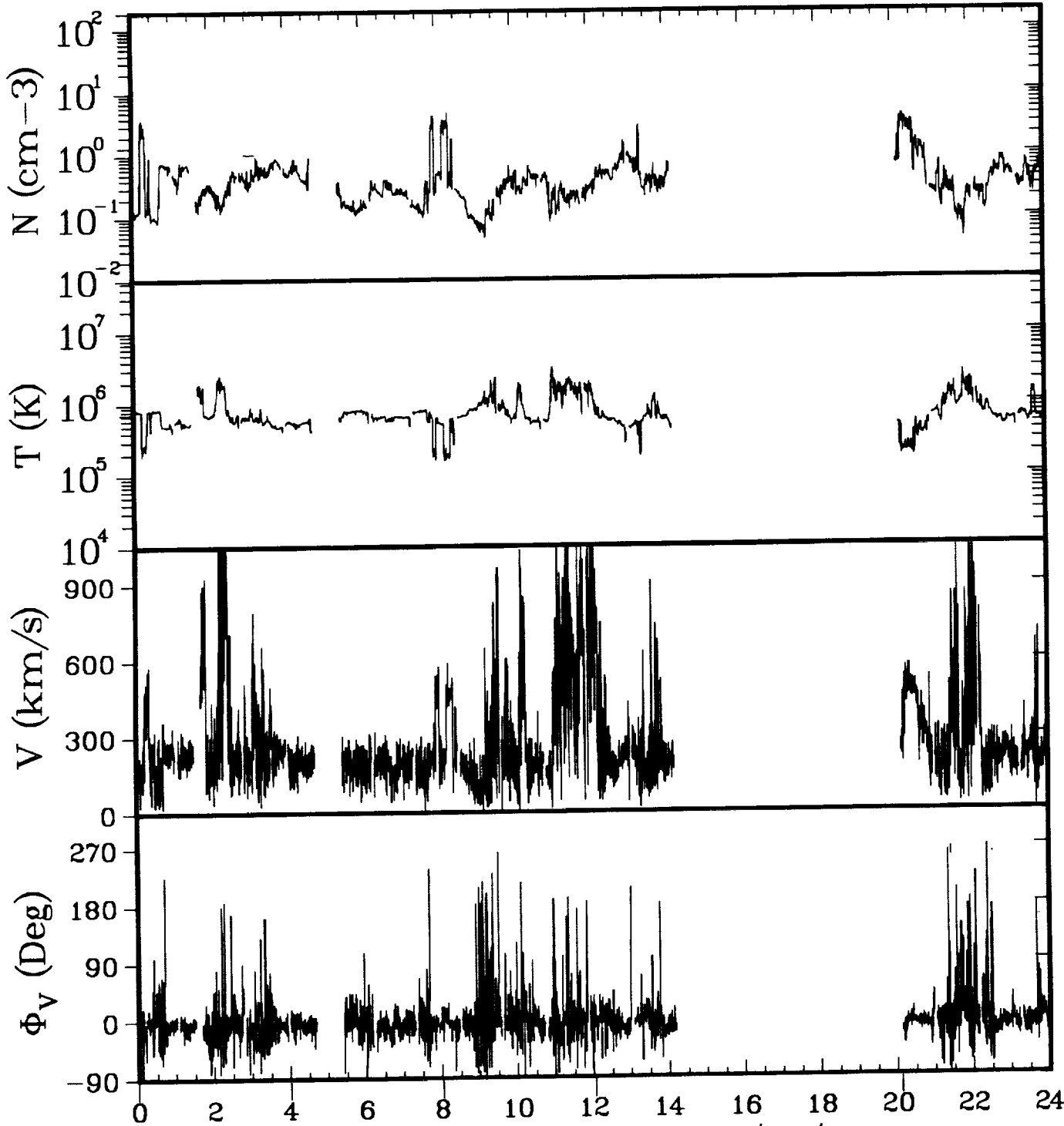

ISEE-3 ELECTRONS 07/30/83

GSEX	-228.9	-228.8	-228.6	-228.5	-228.2
Y	15.3	15.3	15.3	15.3	15.2
Z	8.6	8.7	8.8	8.9	9.2
GSMY	15.8	16.8	17.5	17.6	15.9
Z	7.8	5.2	1.9	1.2	8.0

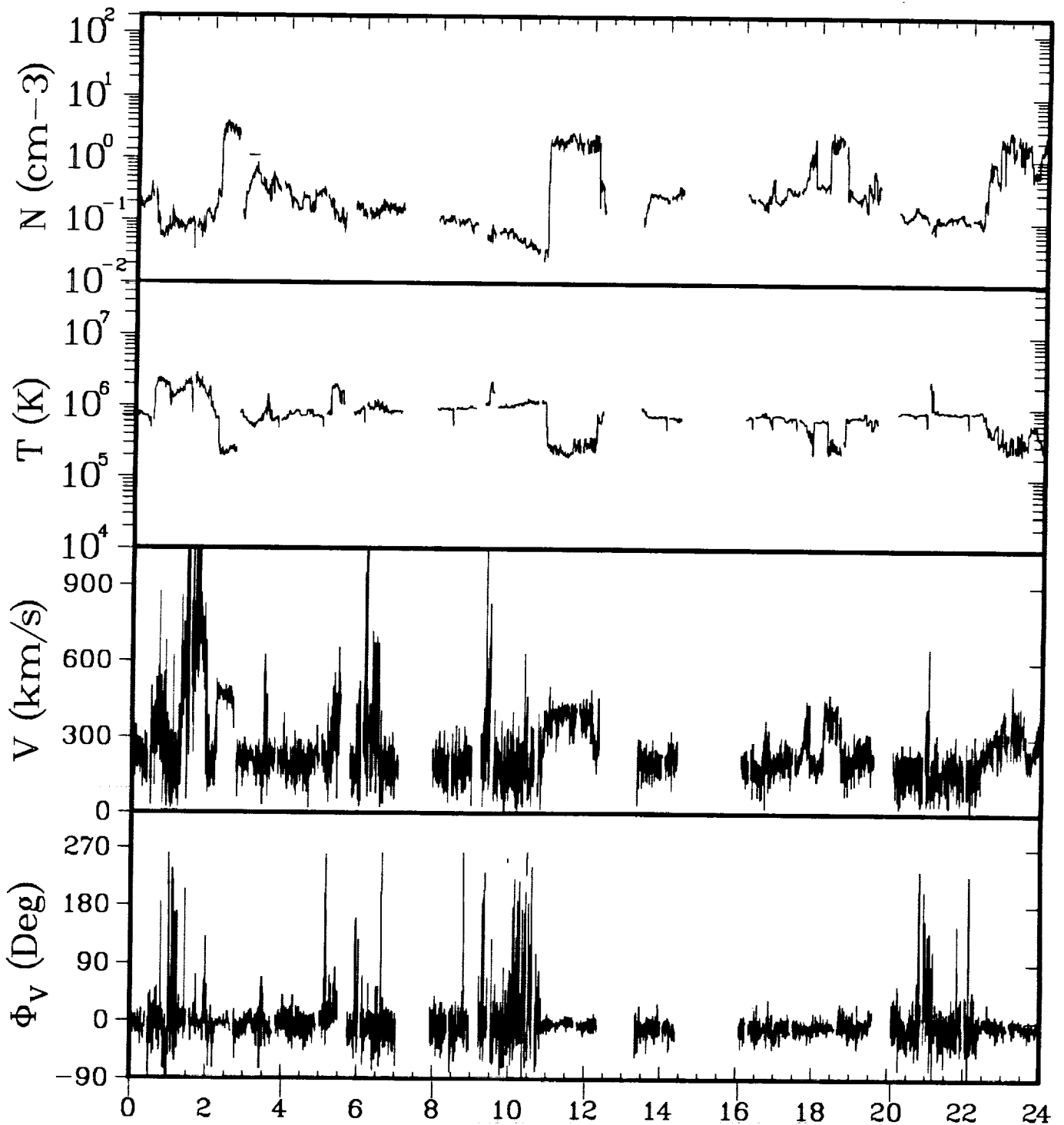

ISEE-3 ELECTRONS 07/31/83

GSEX	-228.1	-228.0	-227.8	-227.7	-227.6	-227.4
Y	15.2	15.1	15.1	15.1	15.1	15.0
Z	9.3	9.4	9.6	9.7	9.8	9.9
GSMY	15.7	16.8	17.7	17.8	17.3	15.8
Z	8.4	5.9	2.6	1.8	5.0	8.6

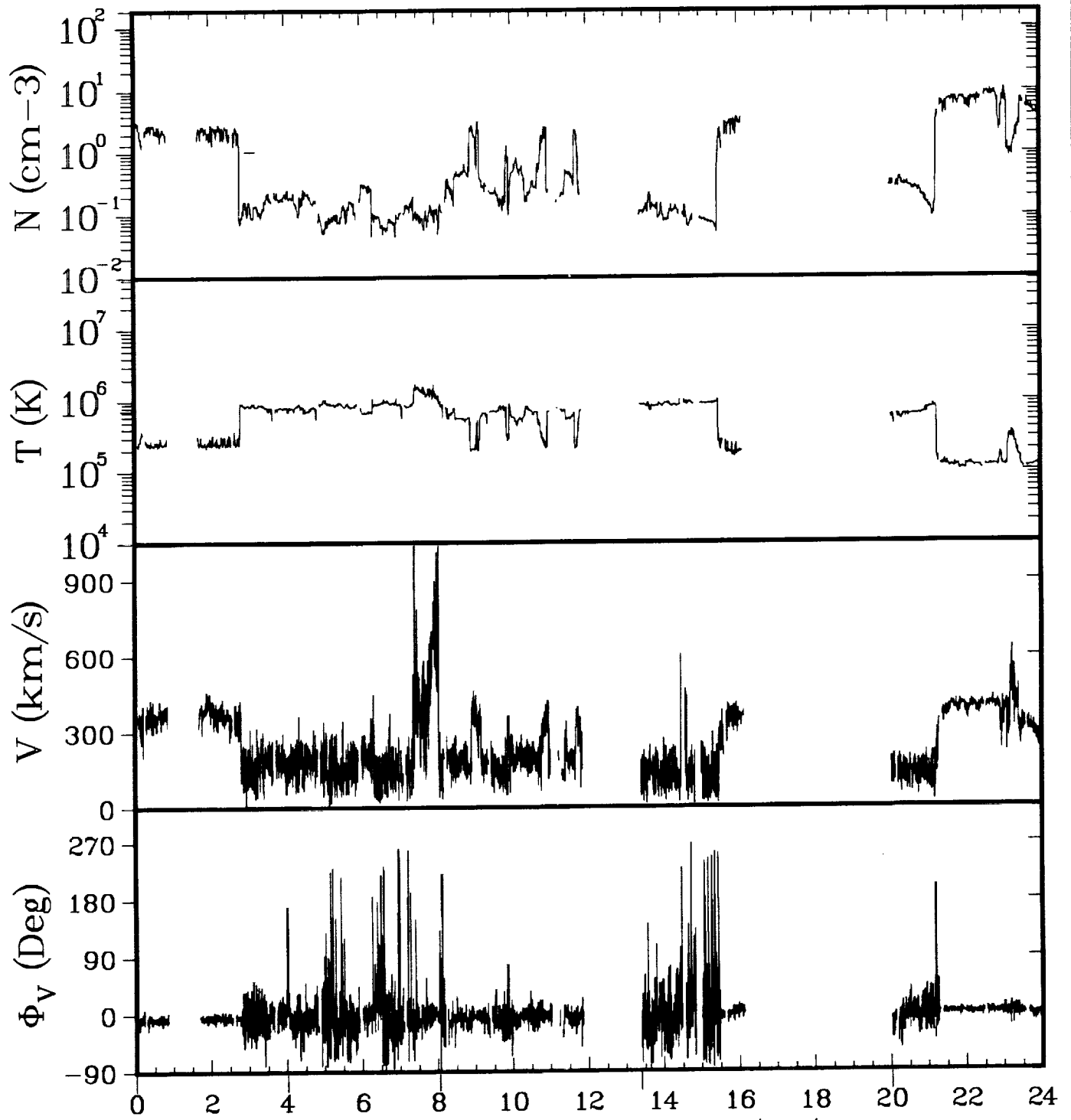

ISEE-3 ELECTRONS 08/01/83

GSEX	-227.3	-227.1	-227.0	-226.8	-226.6
Y	15.0	15.0	14.9	14.9	14.8
Z	10.1	10.2	10.3	10.5	10.7
GSMY	15.6	16.9	17.9	17.9	15.8
Z	9.1	6.6	3.2	3.2	9.3

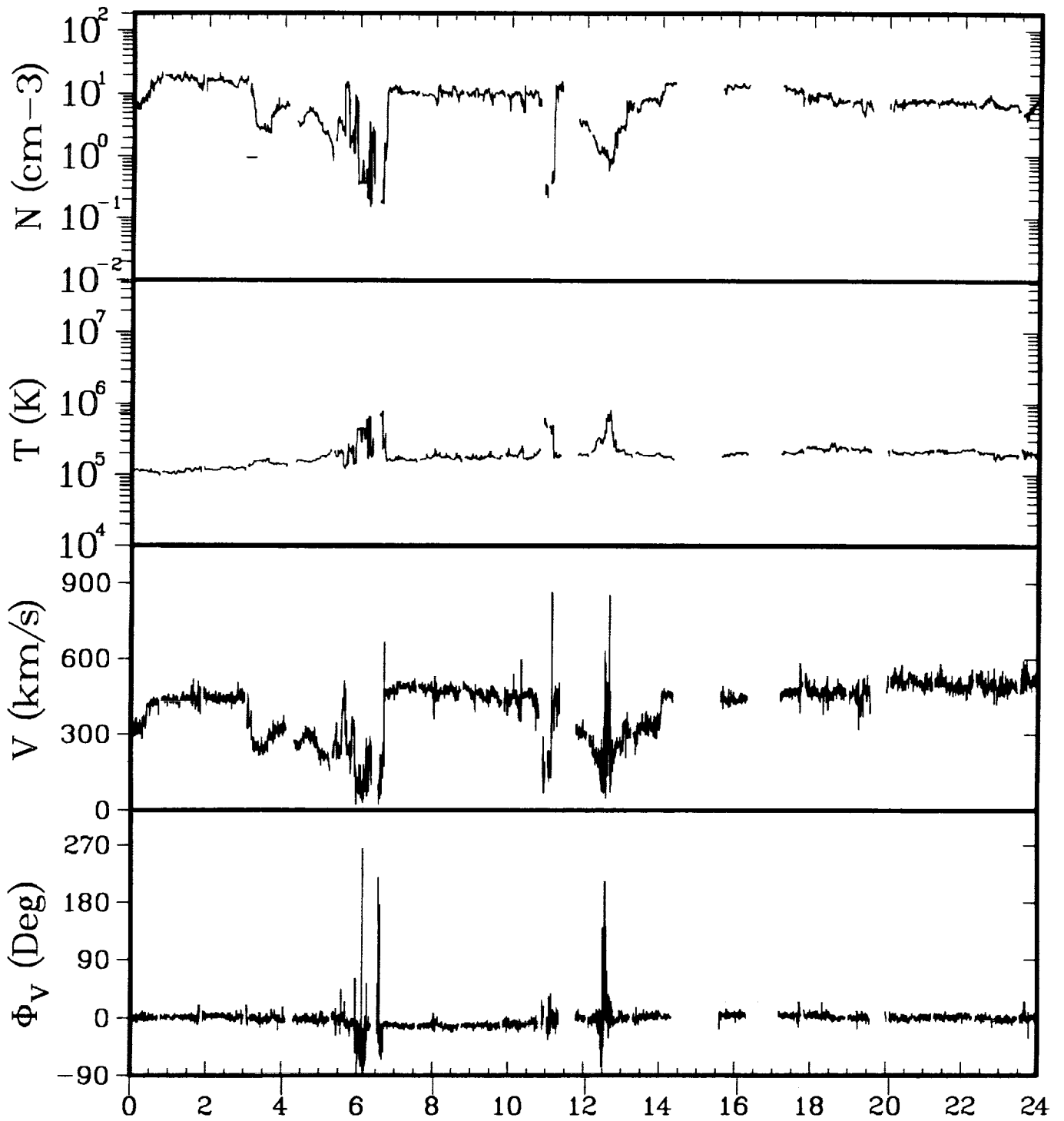

ISEE-3 ELECTRONS 08/02/83

GSEX	-226.4	-226.3	-226.1	-226.0	-225.8	-225.7
Y	14.8	14.8	14.8	14.7	14.7	14.7
Z	10.8	10.9	11.0	11.2	11.3	11.4
GSMY	15.5	16.9	18.0	18.2	17.4	15.7
Z	9.8	7.2	3.9	3.2	6.3	10.0

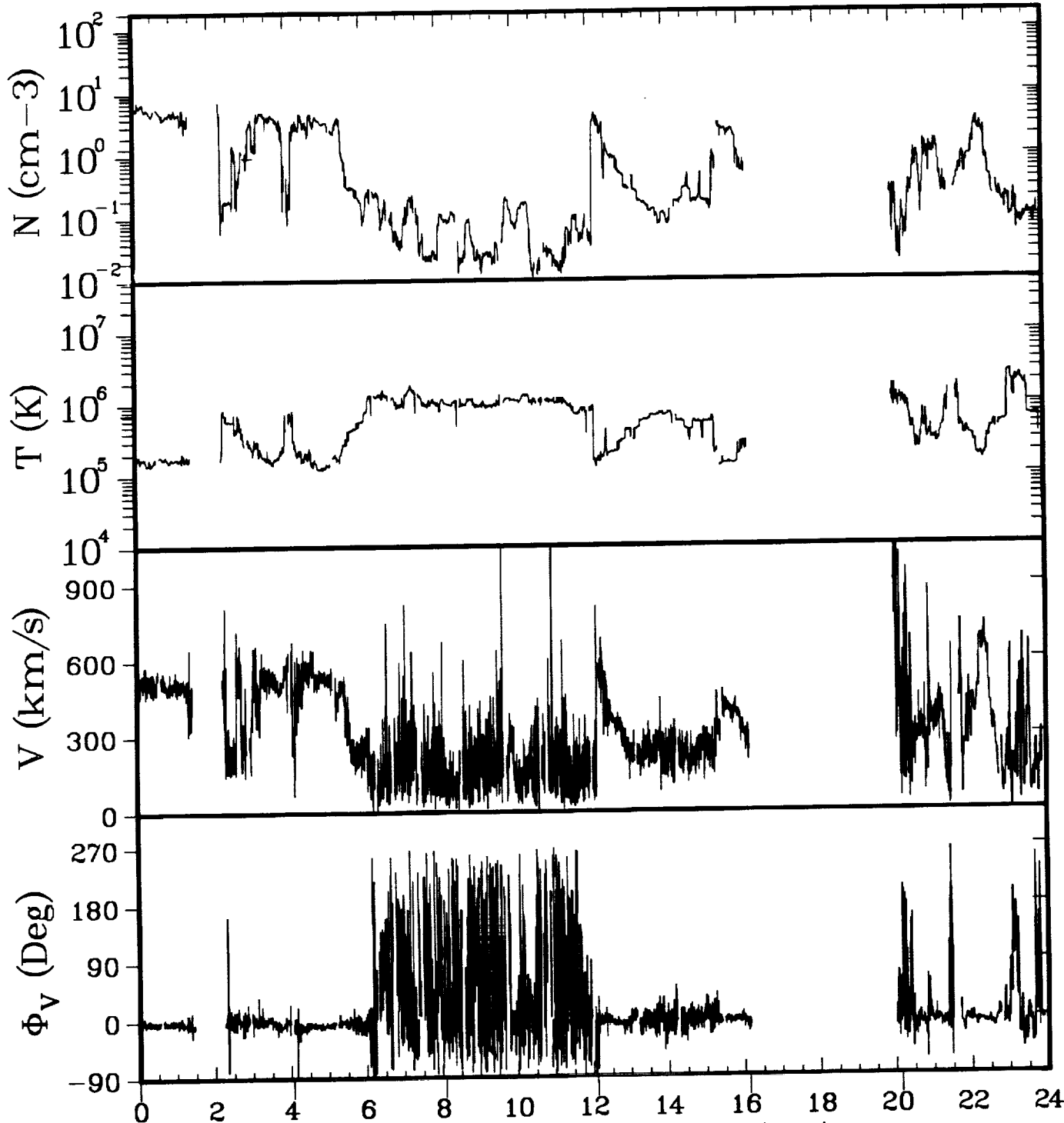

ISEE-3 ELECTRONS 08/03/83

GSEX	-225.5	-225.4	-225.2	-225.1	-224.9	-224.8
Y	14.6	14.6	14.6	14.5	14.5	14.5
Z	11.5	11.6	11.8	11.9	12.0	12.1
GSMY	15.4	16.9	18.2	18.4	17.5	15.6
Z	10.4	7.9	4.5	3.8	7.0	10.6

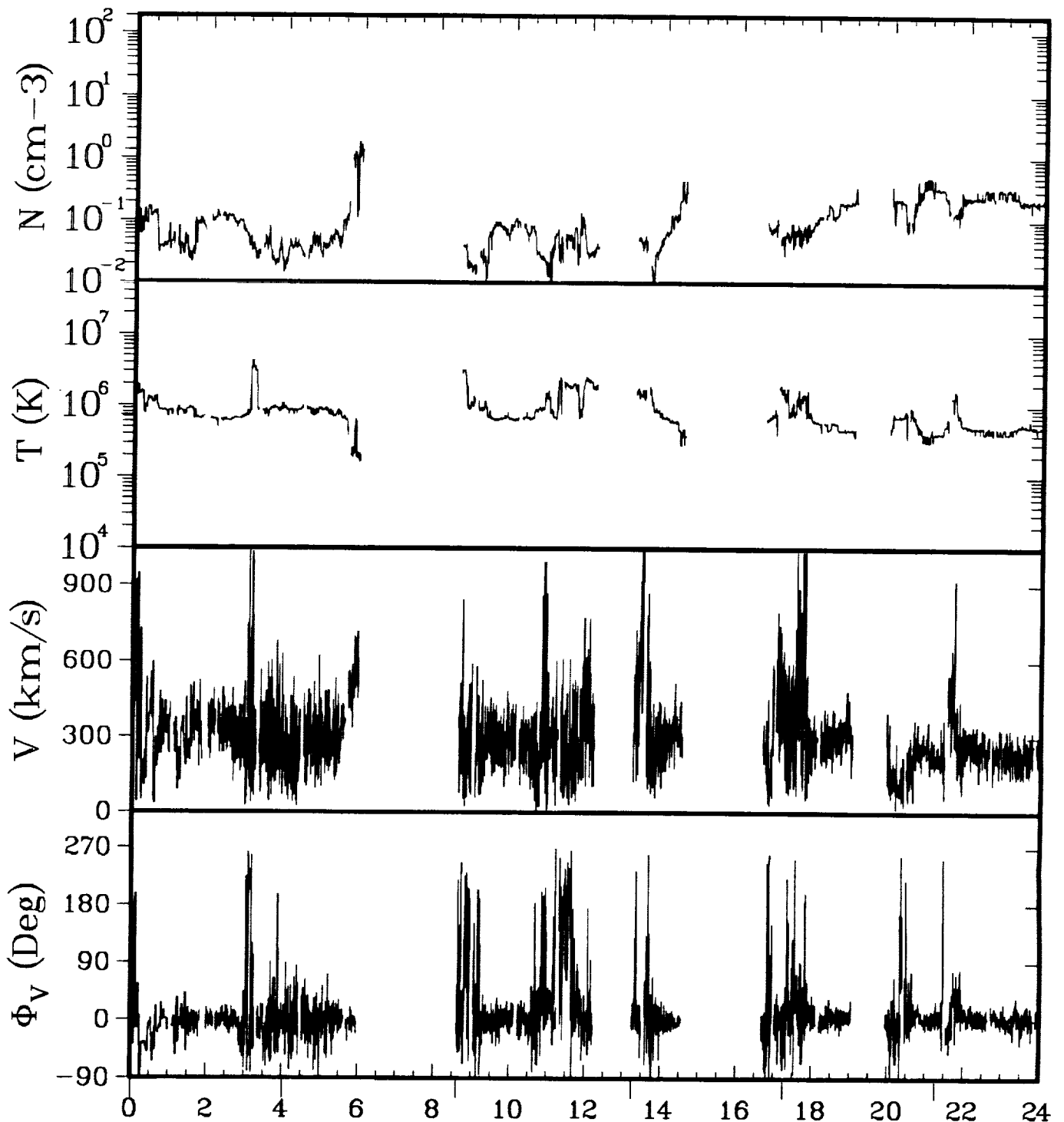

ISEE-3 ELECTRONS 08/04/83

GSEX	-224.6	-224.5	-224.3	-224.1	-223.9	-223.8
Y	14.4	14.4	14.4	14.3	14.3	14.3
Z	12.2	12.4	12.5	12.6	12.7	12.9
GSMY	15.4	16.9	18.4	18.4	17.0	15.2
Z	11.1	8.6	4.8	5.0	8.9	11.7

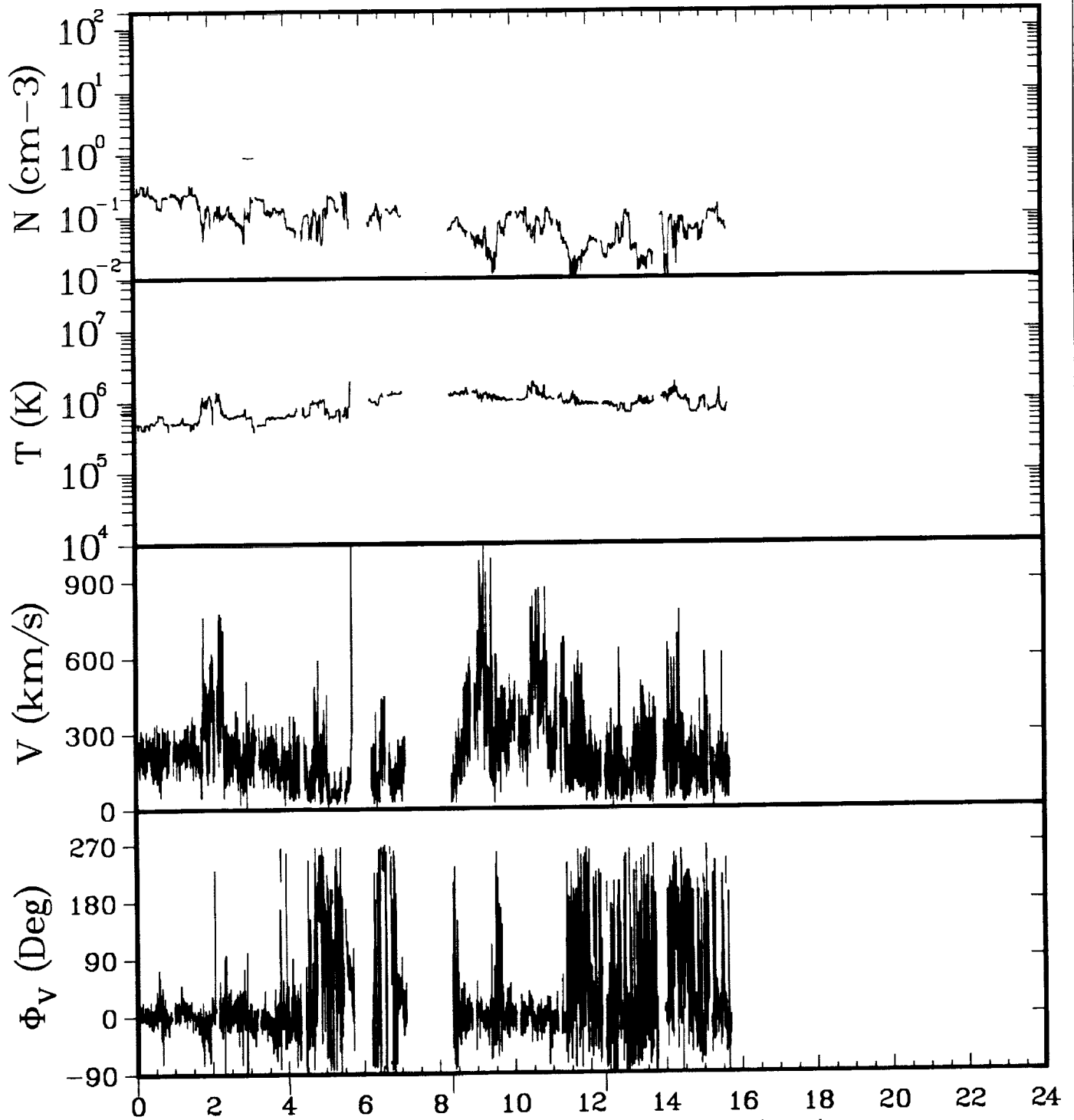

ISEE-3 ELECTRONS 08/05/83

GSEX	-223.7	-223.5	-223.4	-223.2
Y	14.2	14.2	14.2	14.1
Z	12.9	13.1	13.2	13.3
GSMY	15.3	17.0	18.5	18.7
Z	11.7	9.2	5.6	5.2

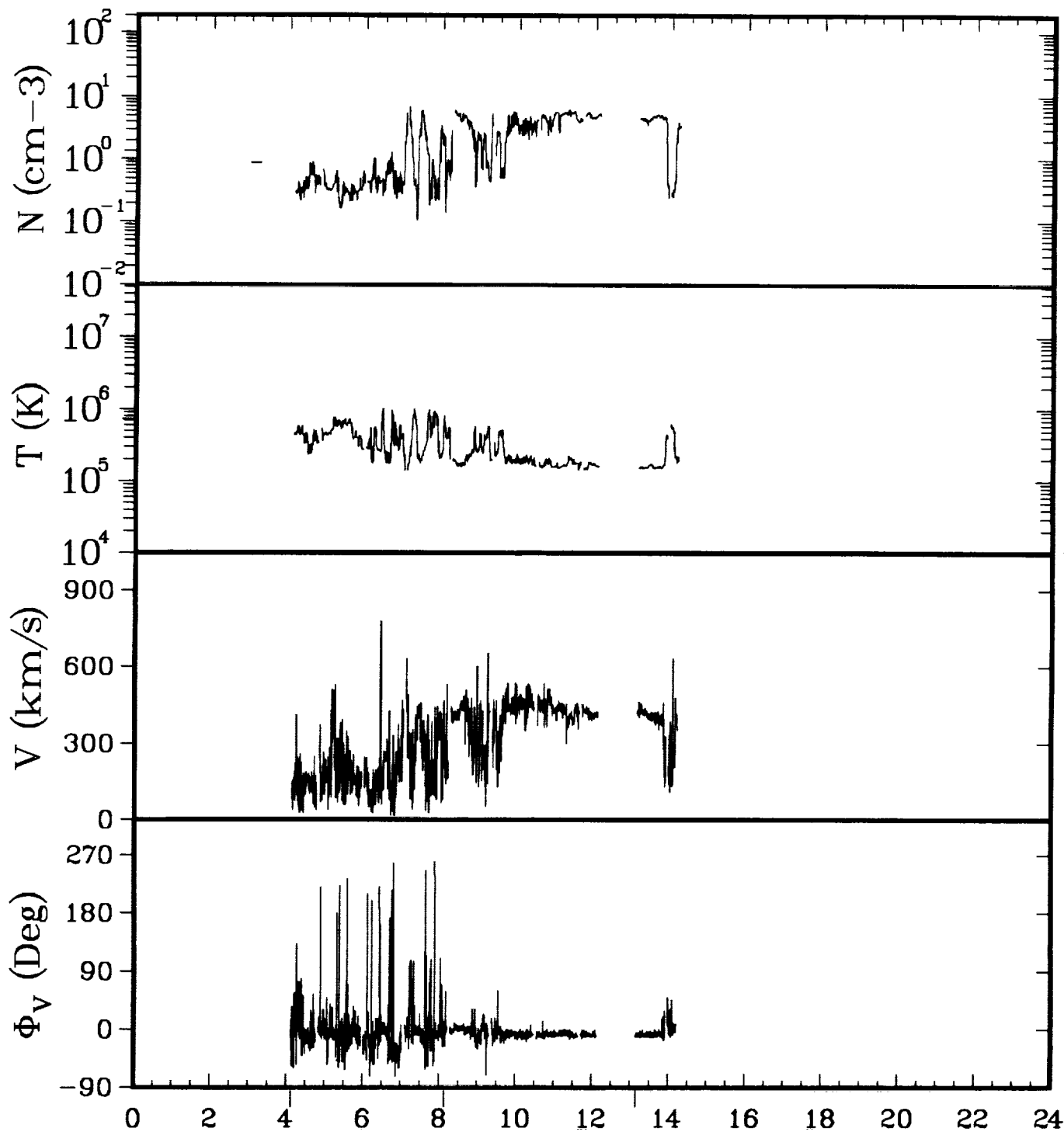

ISEE-3 ELECTRONS 08/06/83

GSEX	-222.6	-222.4	-222.2
Y	14.0	14.0	13.9
Z	13.7	13.9	14.0
GSMY	17.0	18.6	18.7
Z	9.7	6.4	6.2

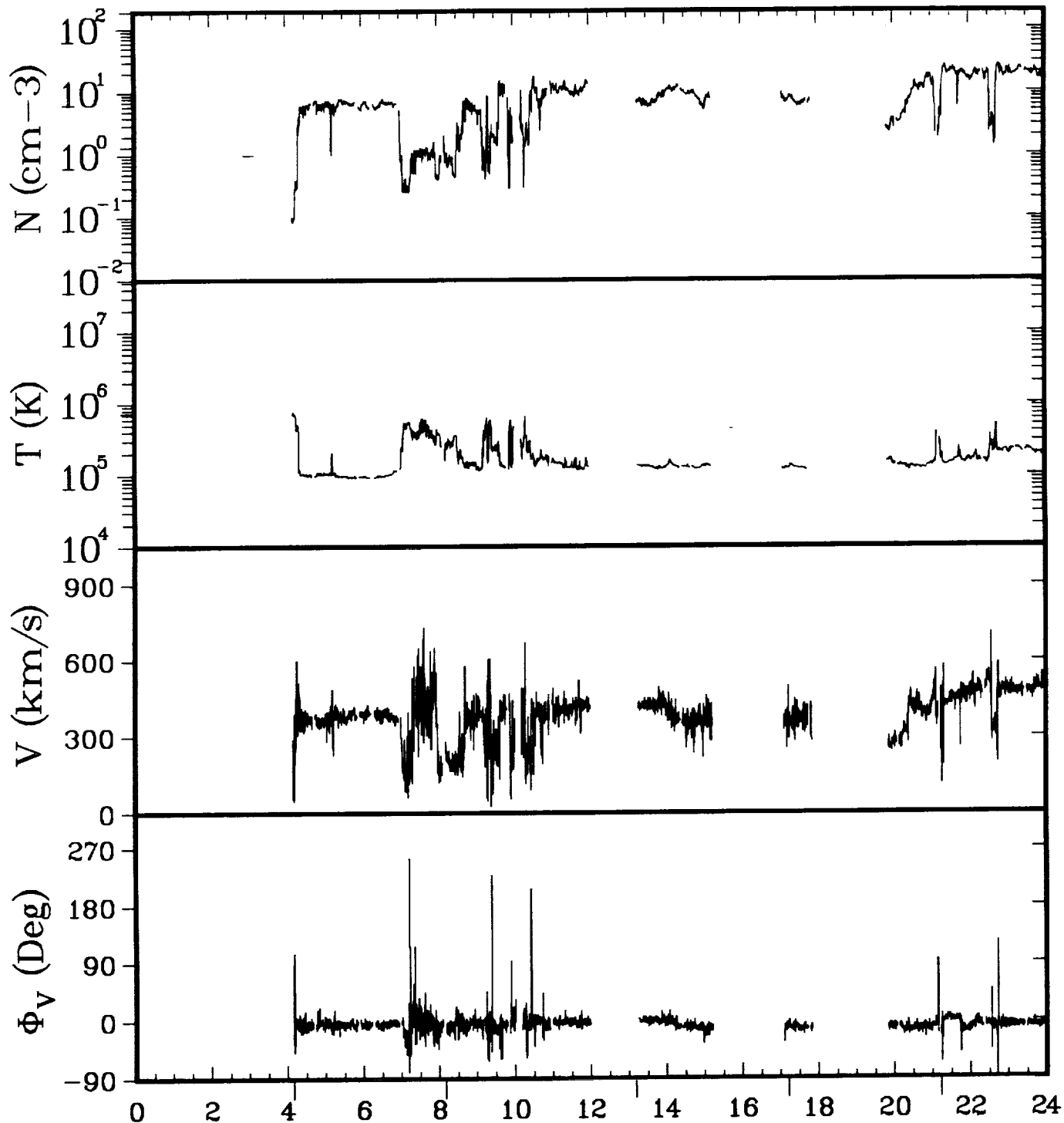

ISEE-3 ELECTRONS 08/07/83

GSEX	-221.6	-221.5	-221.3	-221.1	-221.0
Y	13.8	13.7	13.7	13.6	13.6
Z	14.4	14.5	14.6	14.8	14.9
GSMY	17.0	18.7	18.8	17.0	14.9
Z	10.3	6.9	6.8	10.7	13.5

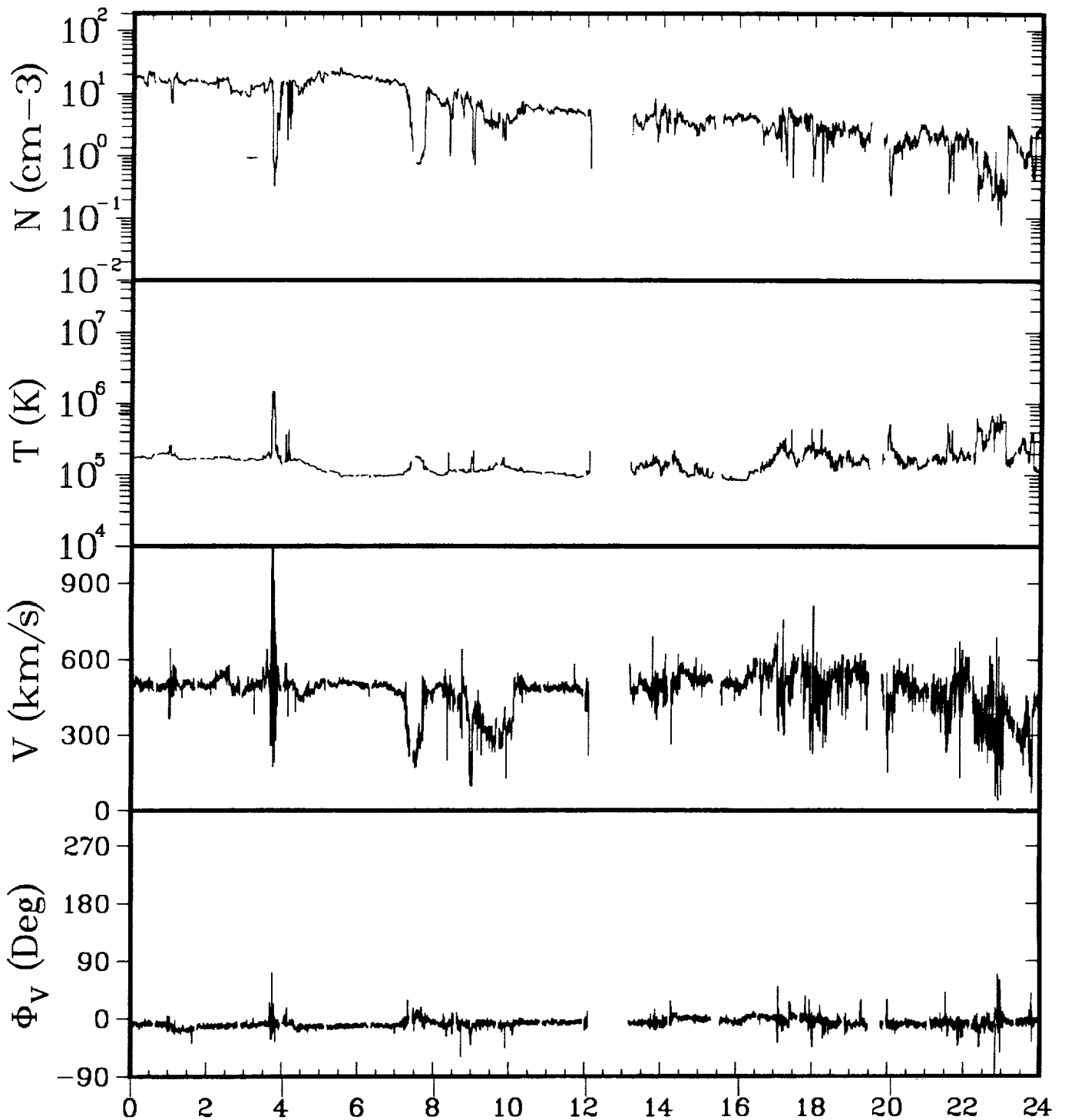

ISEE-3 ELECTRONS 08/08/83

GSEX	-220.9	-220.7	-220.5	-220.4	-220.2	-220.1
Y	13.5	13.5	13.4	13.4	13.4	13.3
Z	14.9	15.0	15.1	15.2	15.4	15.5
GSMY	14.9	16.9	18.8	19.1	17.7	15.1
Z	13.5	11.0	7.6	6.9	10.1	13.6

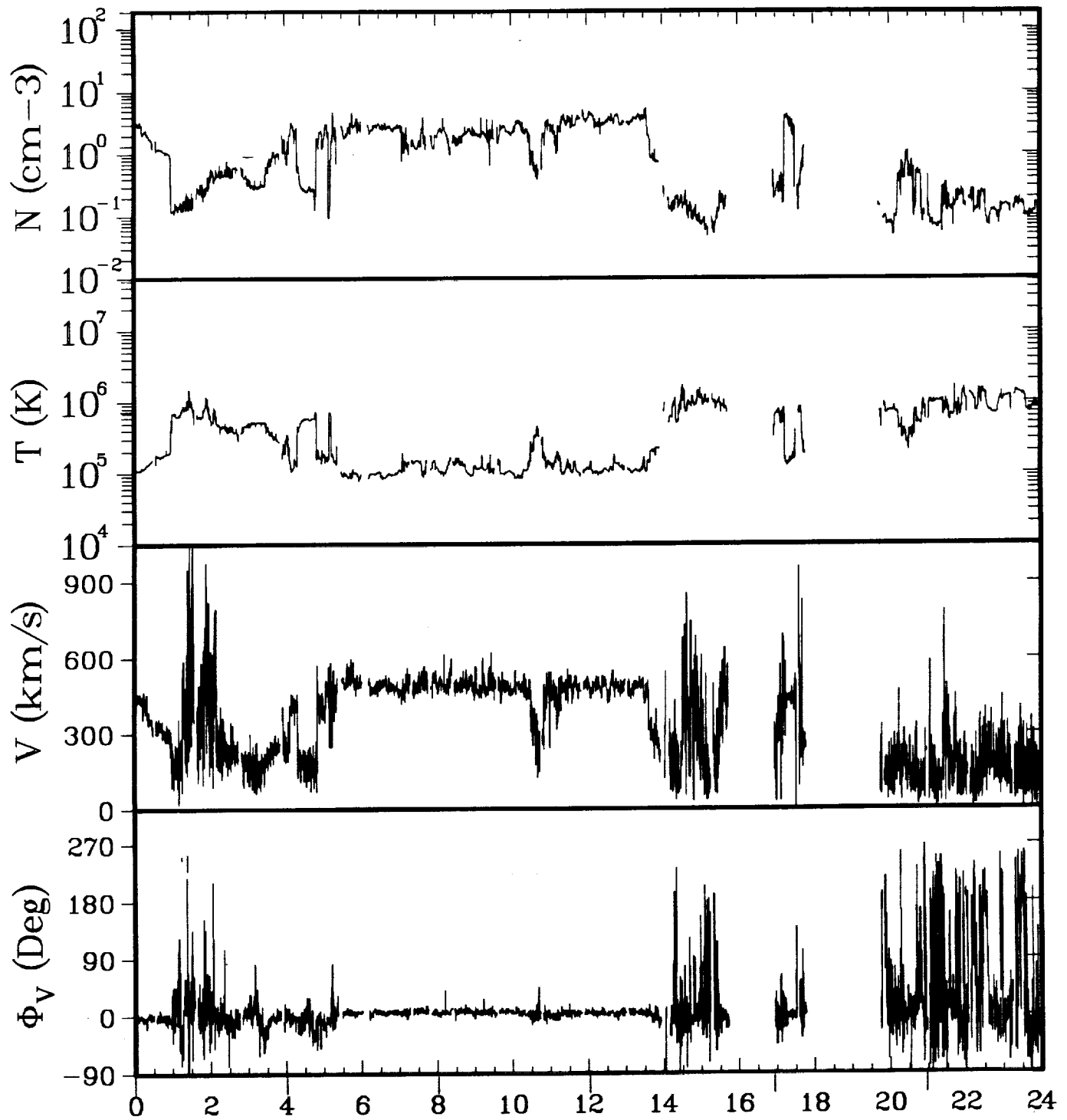

ISEE-3 ELECTRONS 08/09/83

GSEX	-219.9	-219.8	-219.6	-219.4	-219.3	-219.1
Y	13.3	13.2	13.1	13.1	13.0	13.0
Z	15.6	15.7	15.8	15.9	16.0	16.1
GSMY	14.8	16.8	18.8	19.2	17.0	14.6
Z	14.1	11.6	8.2	7.5	11.6	14.6

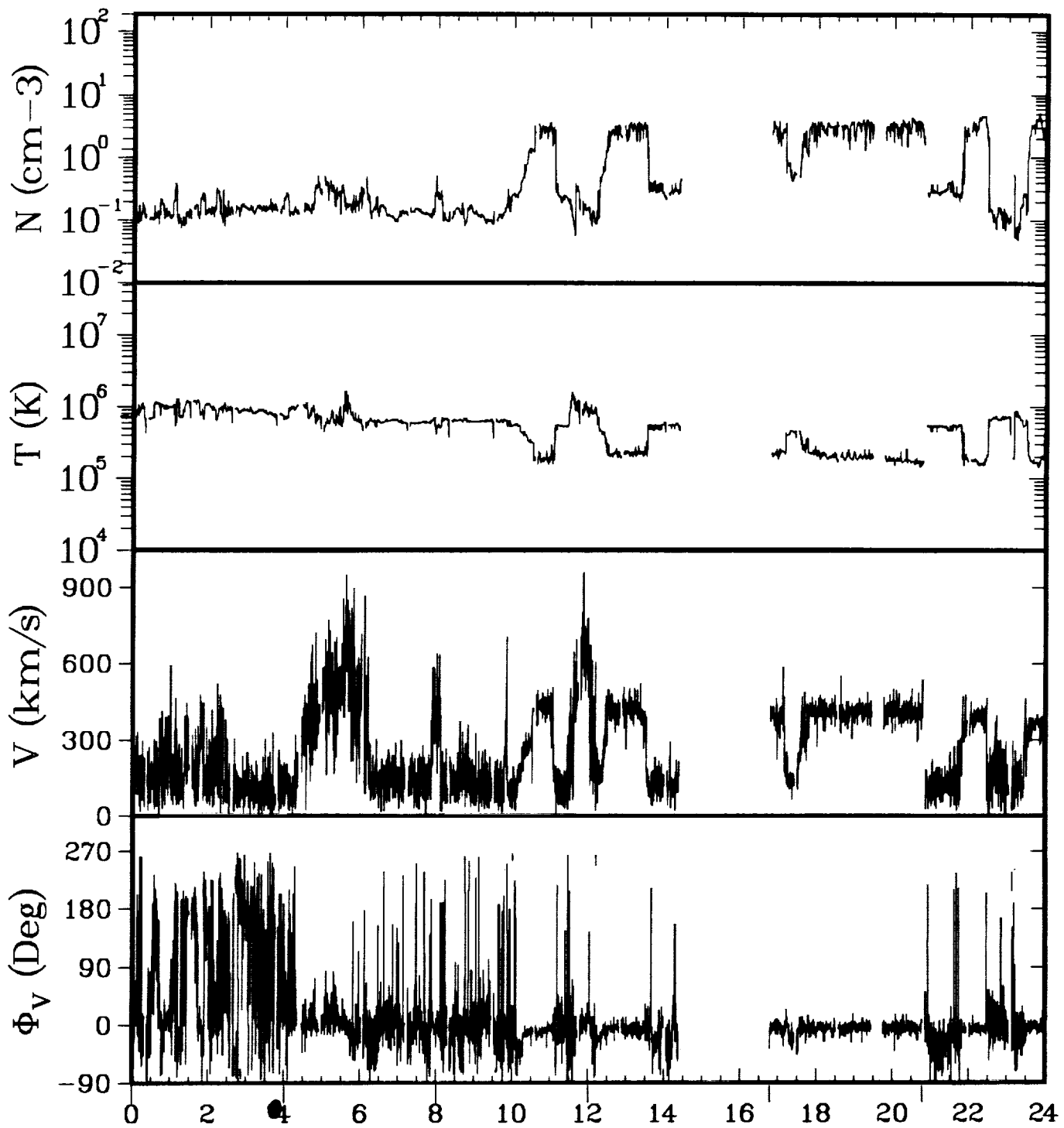

ISEE-3 ELECTRONS 08/10/83

GSEX	-219.0	-218.8	-218.7	-218.5	-218.3	-218.2
Y	12.9	12.9	12.8	12.7	12.6	12.6
Z	16.1	16.2	16.3	16.4	16.6	16.6
GSMY	14.6	16.7	18.8	19.2	17.0	14.4
Z	14.7	12.2	8.9	8.1	12.0	15.1

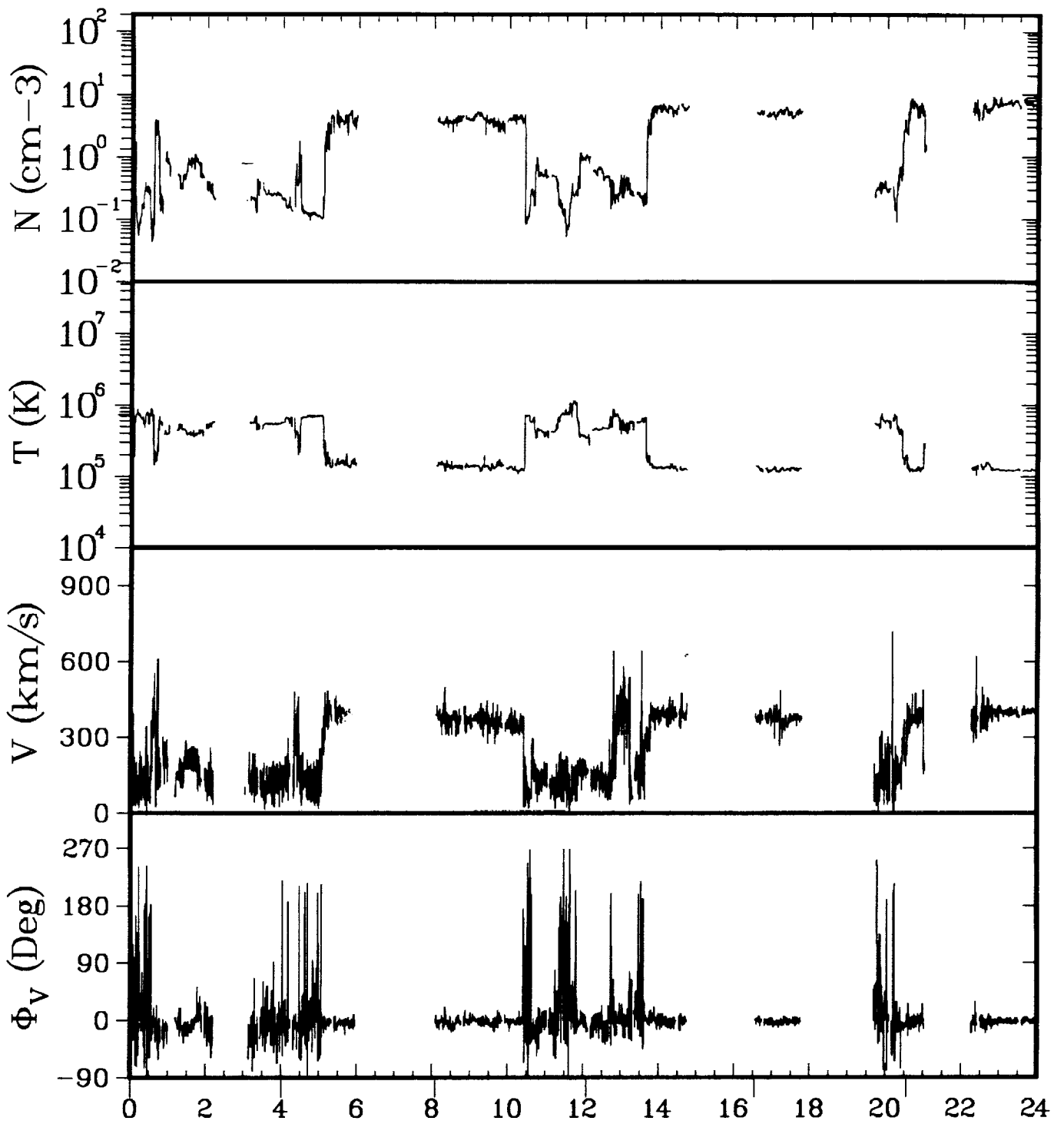

ISEE-3 ELECTRONS 08/11/83

GSEX	-218.0	-217.9	-217.7	-217.6	-217.4	-217.2
Y	12.5	12.4	12.4	12.3	12.2	12.1
Z	16.7	16.8	16.9	17.0	17.1	17.2
GSMY	14.3	16.6	18.7	19.1	17.0	14.2
Z	15.2	12.8	9.4	8.7	12.4	15.5

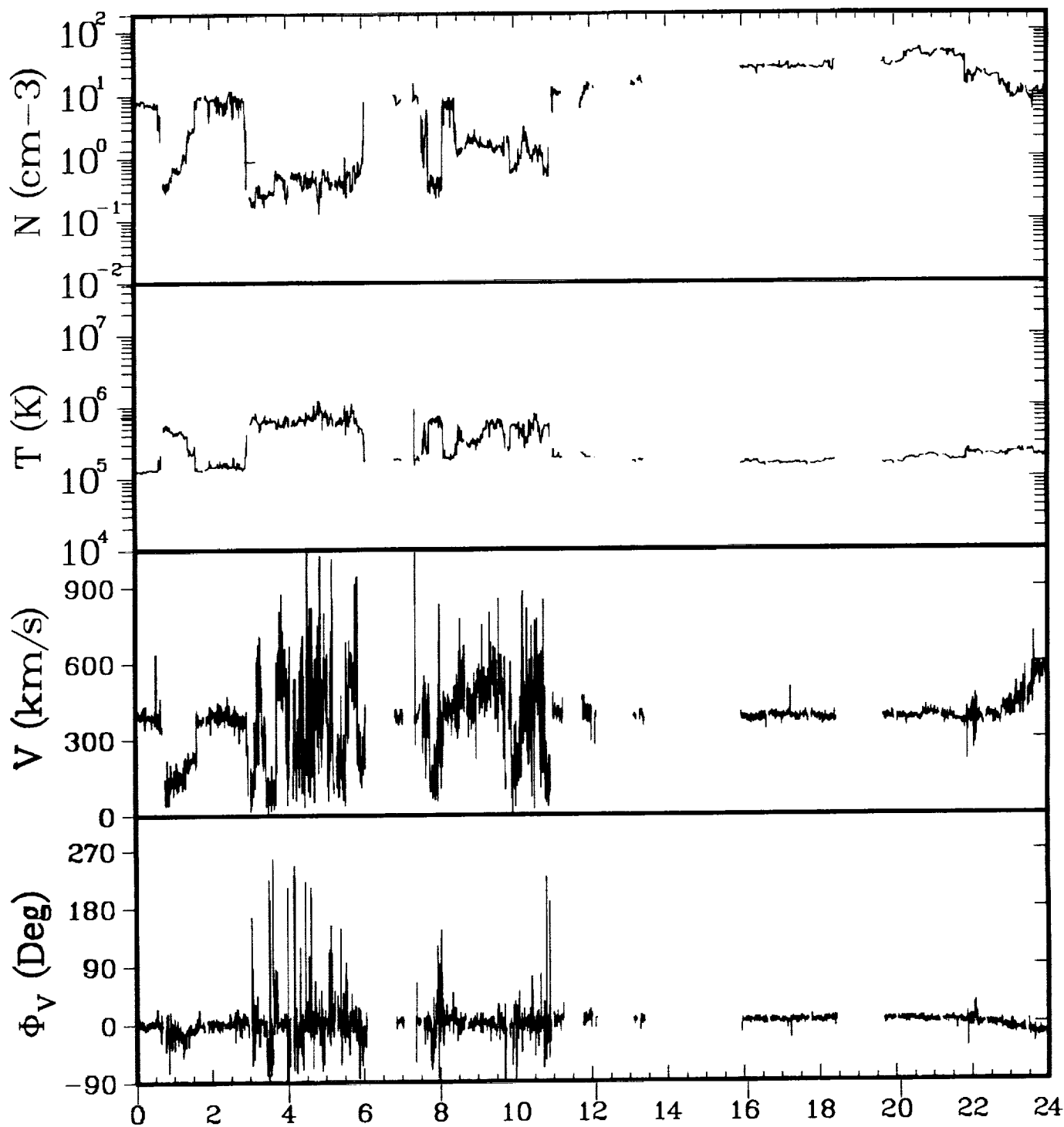

ISEE-3 ELECTRONS 08/12/83

GSEX	-217.1	-216.9	-216.8	-216.6	-216.5	-216.3
Y	12.1	12.0	11.9	11.8	11.7	11.6
Z	17.3	17.4	17.4	17.5	17.6	17.7
GSMY	14.0	16.3	18.5	19.0	17.1	14.1
Z	15.7	13.4	10.1	9.3	12.5	15.8

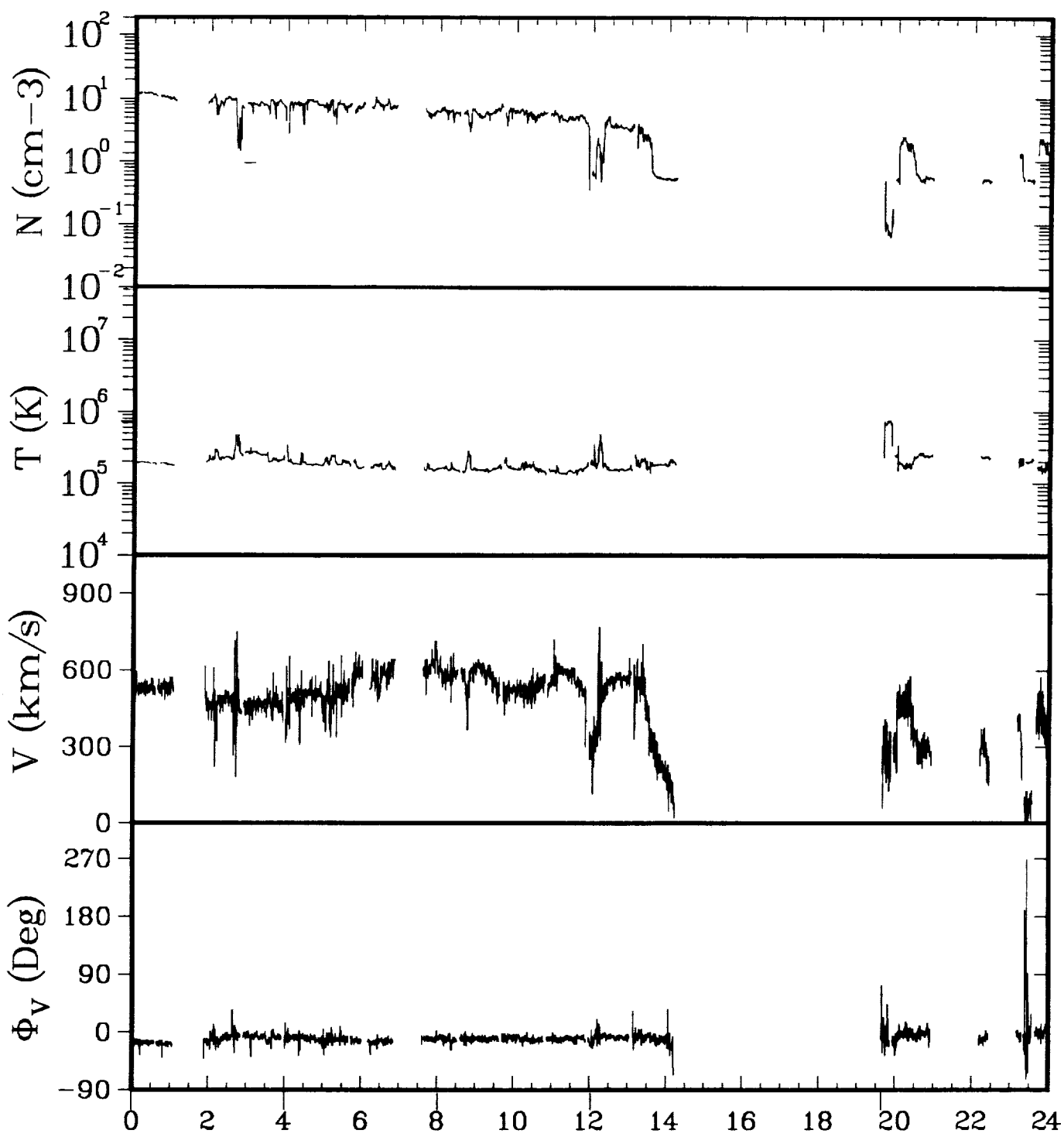

ISEE-3 ELECTRONS 08/13/83

GSEX	-216.2	-216.0	-215.8	-215.7	-215.4
Y	11.5	11.4	11.3	11.2	11.0
Z	17.8	17.9	18.0	18.0	18.2
GSMY	13.6	16.0	18.3	18.8	13.9
Z	16.2	14.0	10.7	10.0	16.1

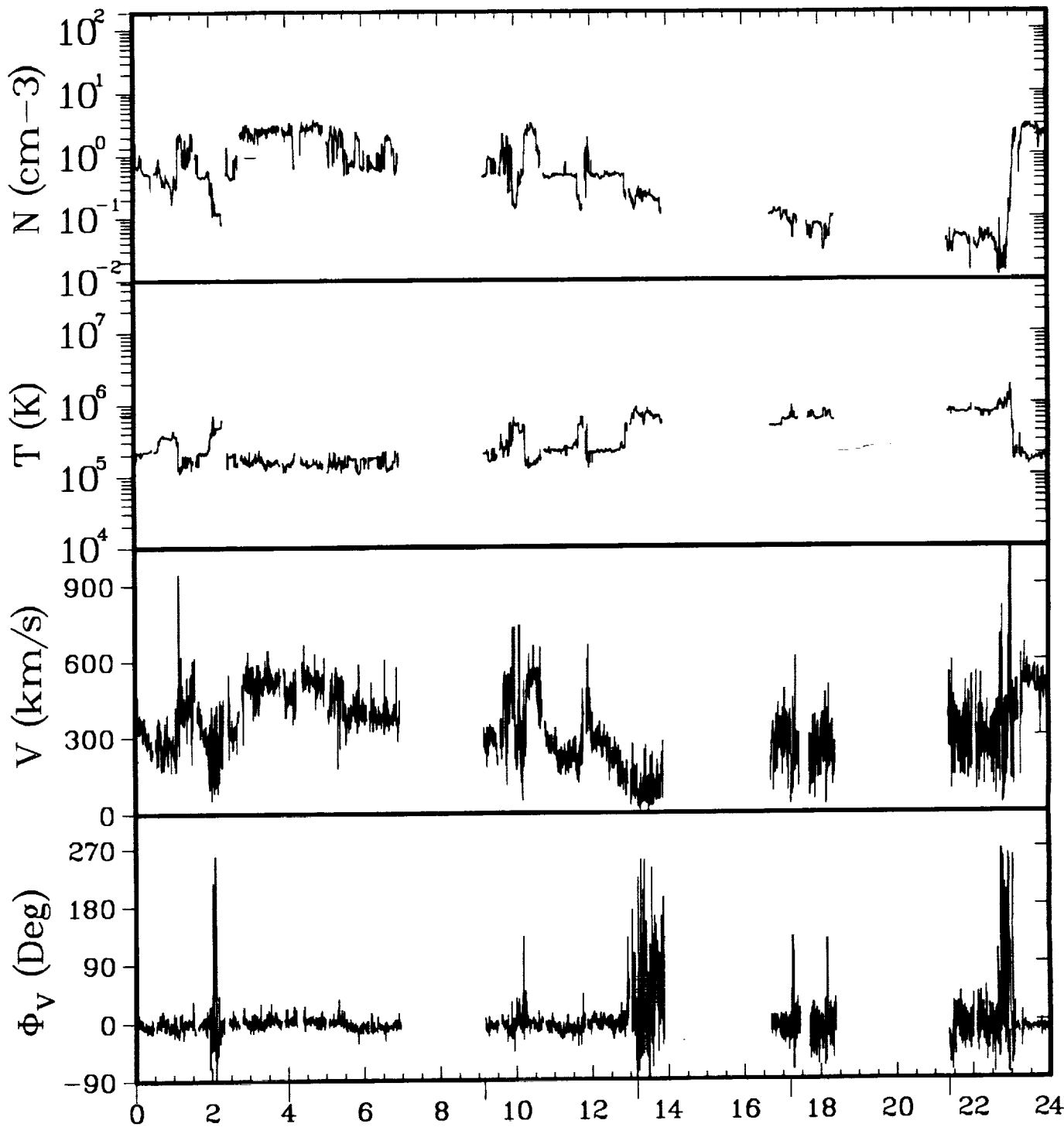

ISEE-3 ELECTRONS 08/14/83

GSEX	-215.0	-215.0	-214.8	-214.6	-214.5	-214.3
Y	10.9	10.8	10.7	10.5	10.4	10.3
Z	18.3	18.4	18.5	18.5	18.6	18.7
GSMY	13.1	15.6	18.4	18.1	15.4	12.5
Z	16.7	14.5	10.8	11.2	14.8	17.3

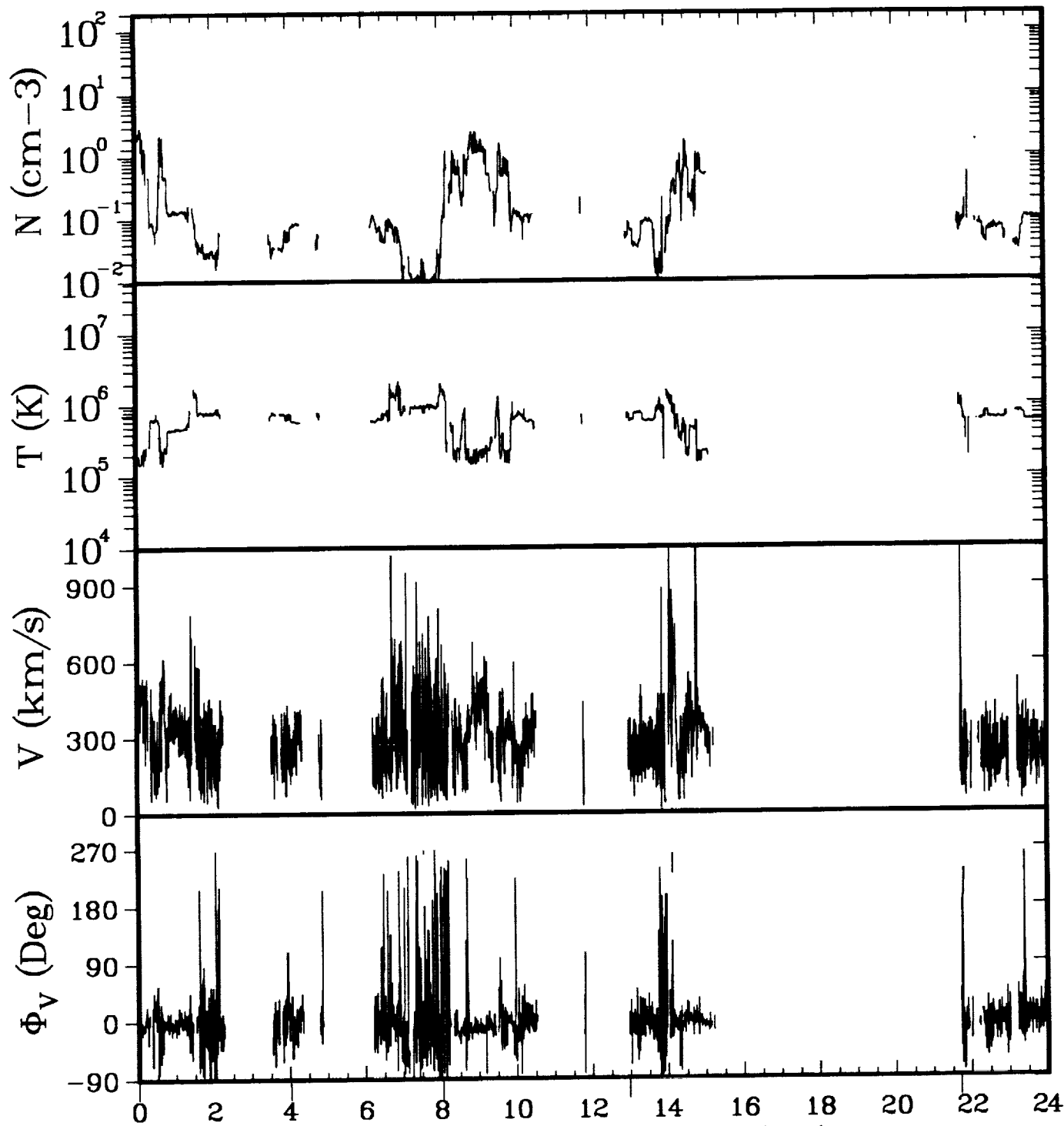

ISEE-3 ELECTRONS 08/15/83

GSEX	-214.2	-214.0	-213.8	-213.6	-213.2
Y	10.2	10.1	10.0	9.8	9.5
Z	18.7	18.8	18.9	19.0	19.1
GSMY	12.6	15.1	17.7	17.8	11.8
Z	17.2	15.1	12.0	11.8	17.8

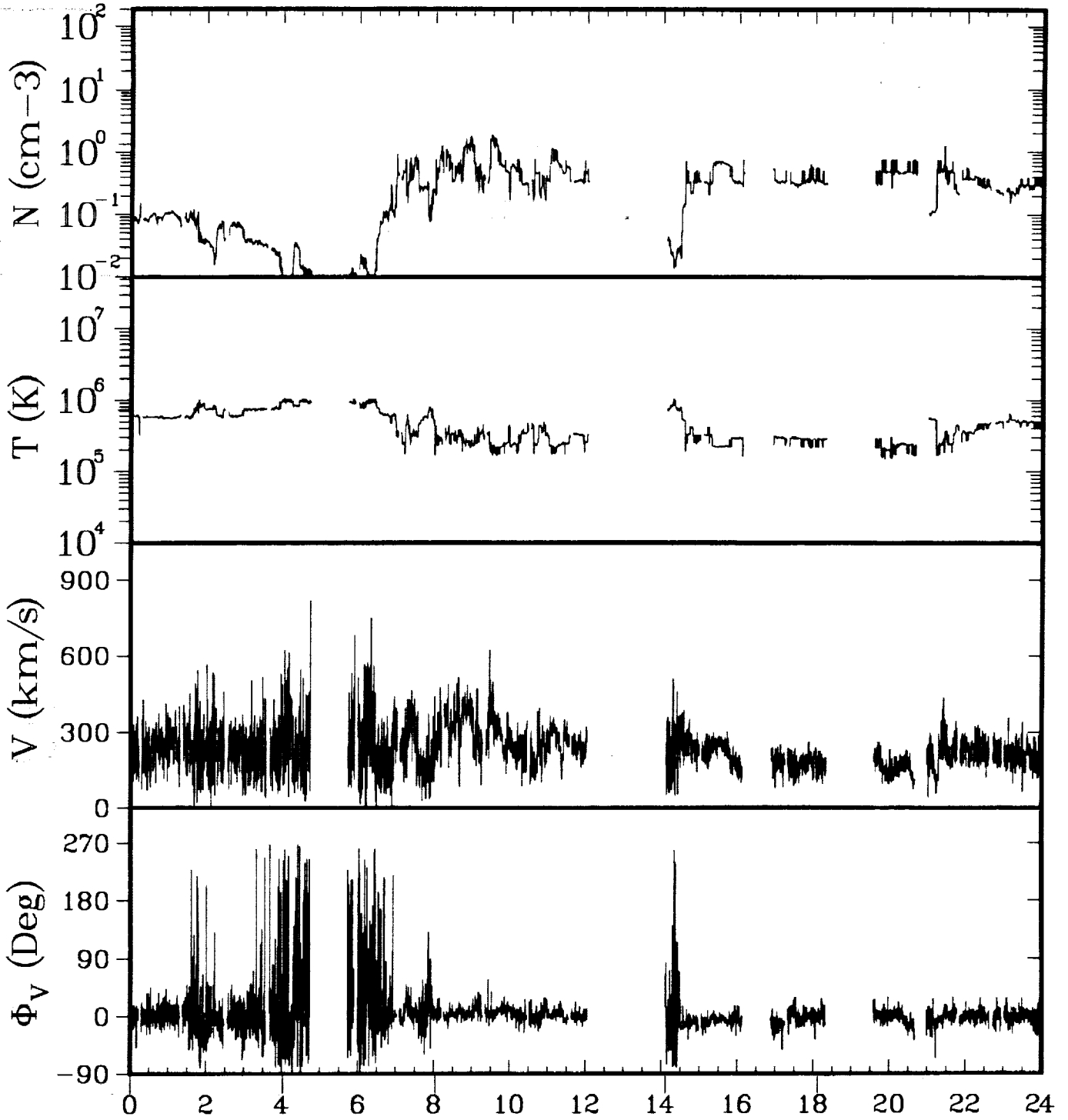

ISEE-3 ELECTRONS 08/16/83

GSEX	-213.1	-212.9	-212.8	-212.5	-212.3
Y	9.4	9.3	9.2	8.9	8.8
Z	19.2	19.2	19.3	19.4	19.5
GSMY	11.9	14.5	17.2	16.8	13.3
Z	17.7	15.7	12.7	13.2	16.7

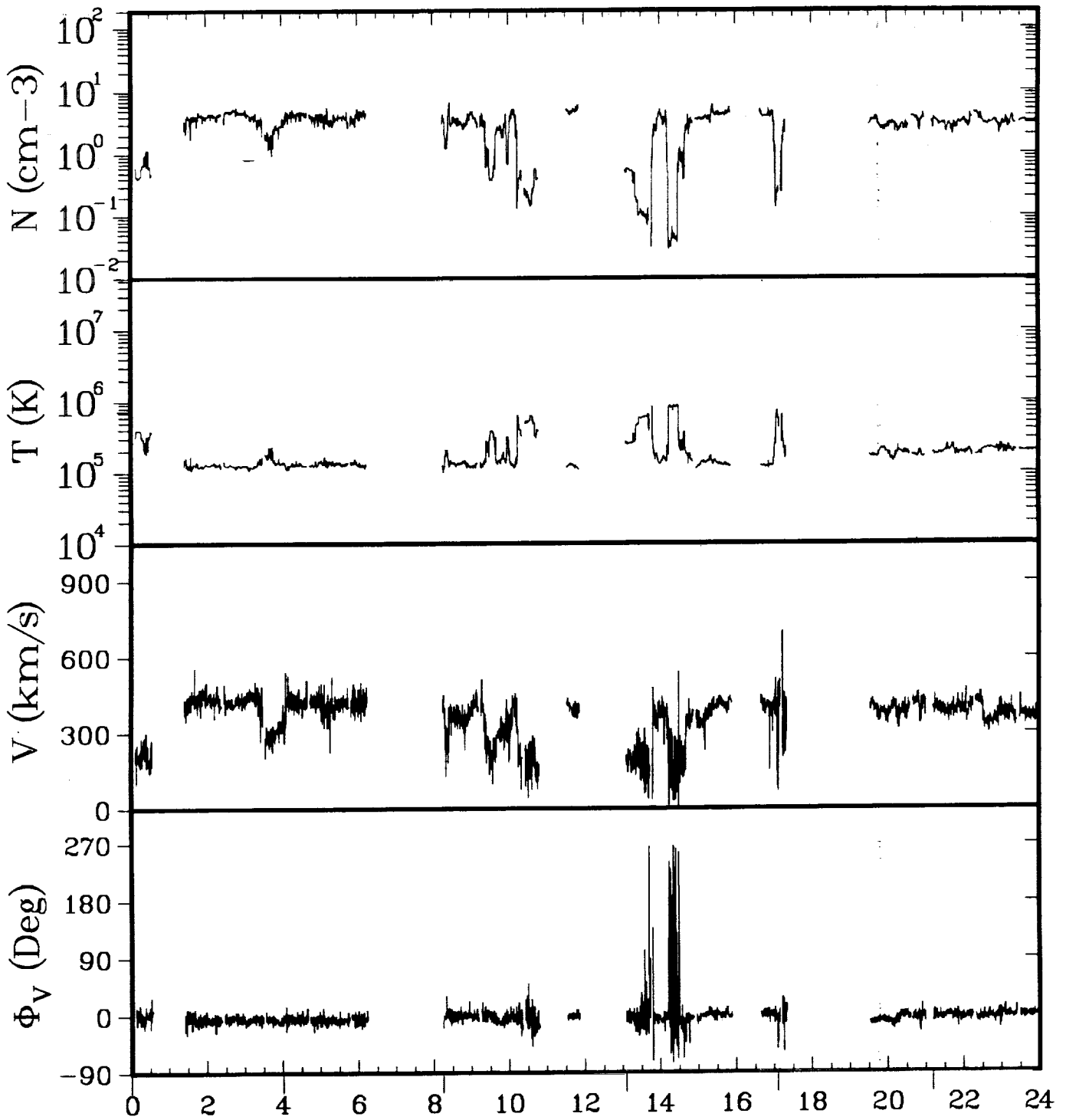

ISEE-3 ELECTRONS 08/17/83

GSEX	-212.0	-211.8	-211.6	-211.4	-211.2	-211.0
Y	8.6	8.4	8.3	8.1	7.9	7.7
Z	19.6	19.6	19.7	19.8	19.8	19.9
GSMY	11.2	13.9	16.7	16.8	13.6	10.4
Z	18.2	16.3	13.3	13.3	16.4	18.6

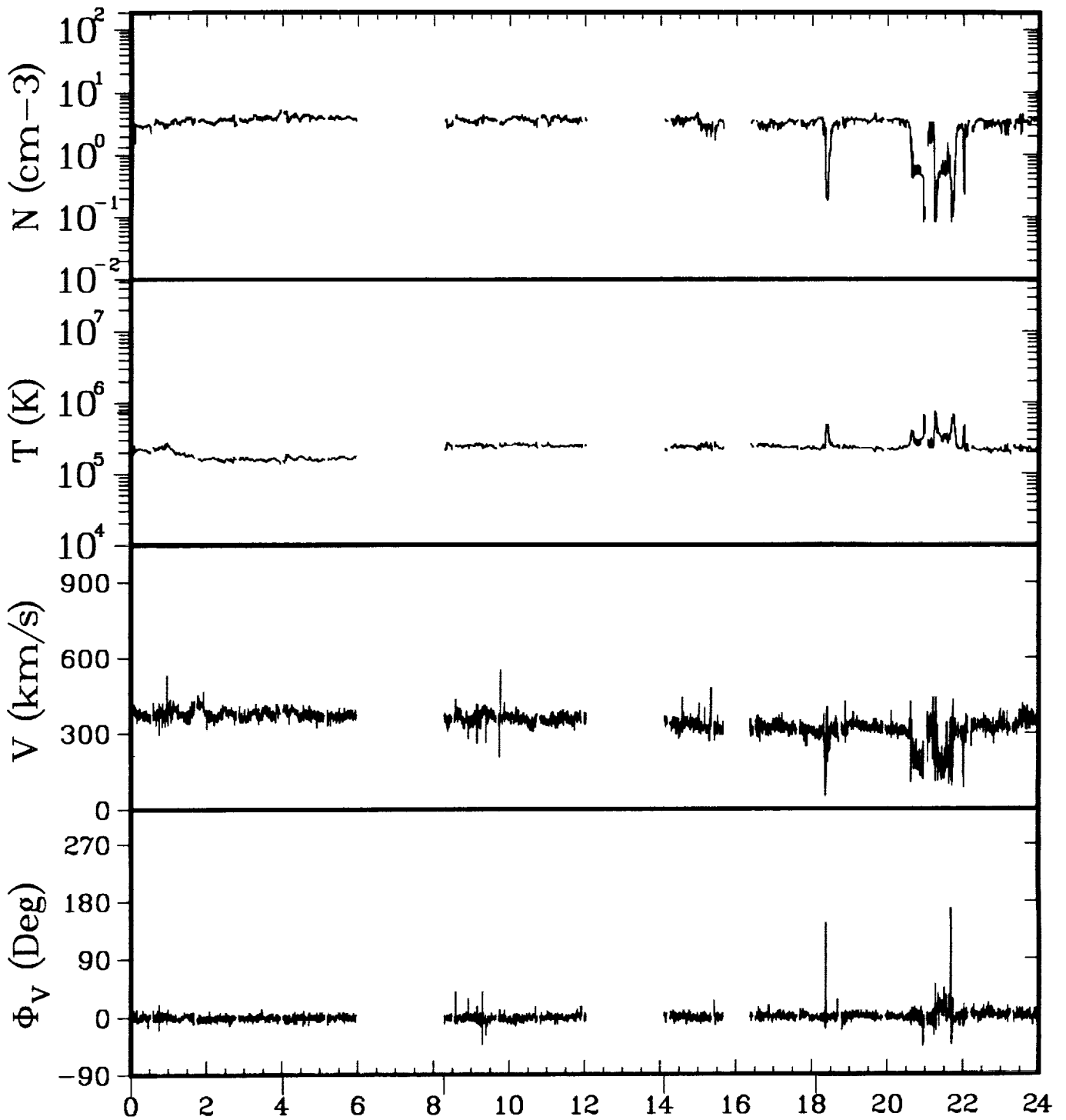

ISEE-3 ELECTRONS 08/18/83

GSEX	-210.9	-210.7	-210.5	-210.2	-210.0
Y	7.6	7.5	7.3	7.0	6.9
Z	19.9	20.0	20.1	20.1	20.2
GSMY	10.4	13.1	16.1	15.5	11.8
Z	18.6	16.8	14.0	14.6	17.8

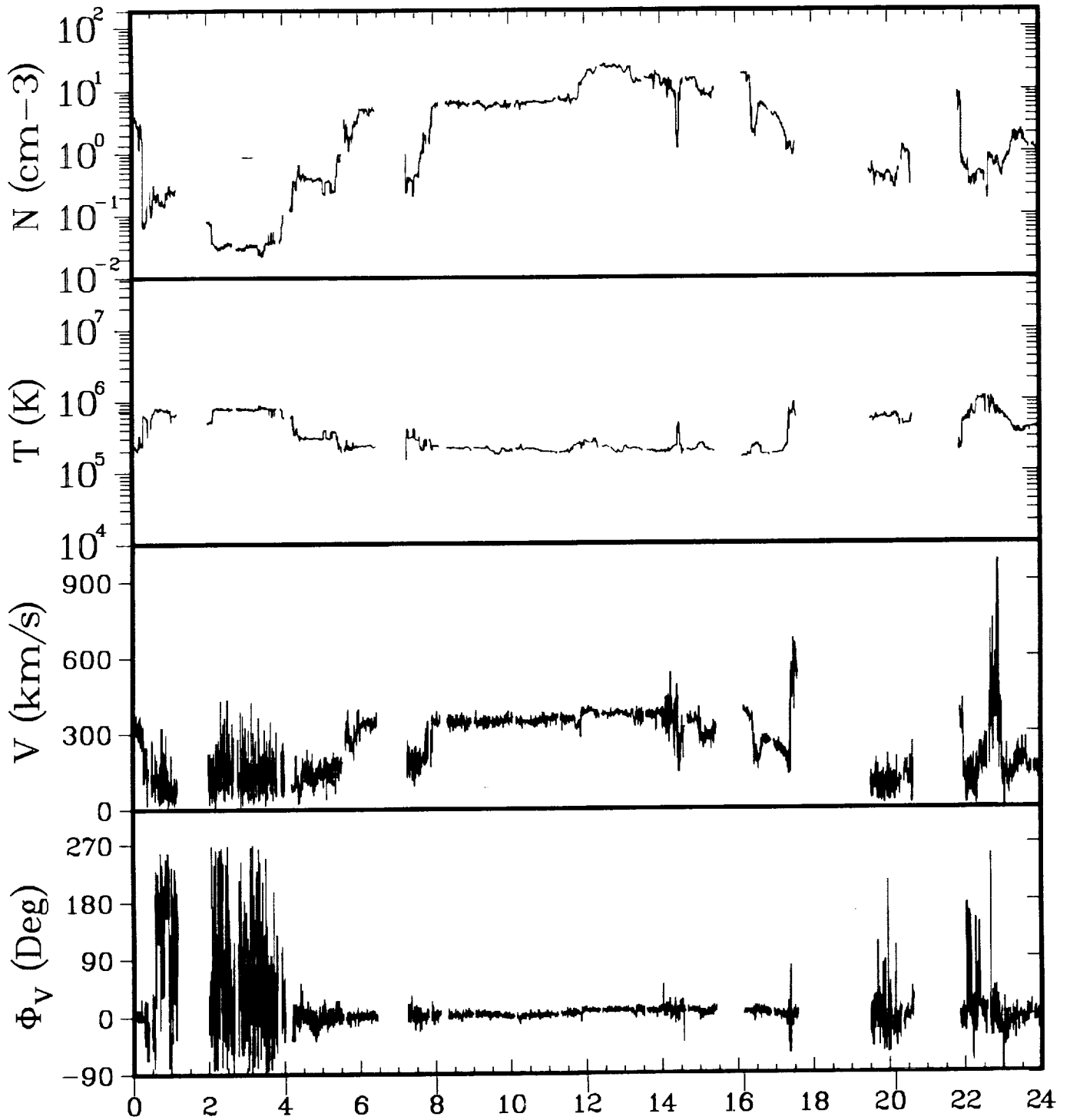

ISEE-3 ELECTRONS 08/19/83

GSEX	-209.7	-209.5	-209.2	-209.0	-208.8	-208.6
Y	6.6	6.4	6.3	6.1	5.9	5.7
Z	20.3	20.3	20.4	20.4	20.5	20.5
GSMY	9.5	12.3	15.3	15.8	13.0	9.1
Z	19.1	17.4	14.9	14.3	16.9	19.3

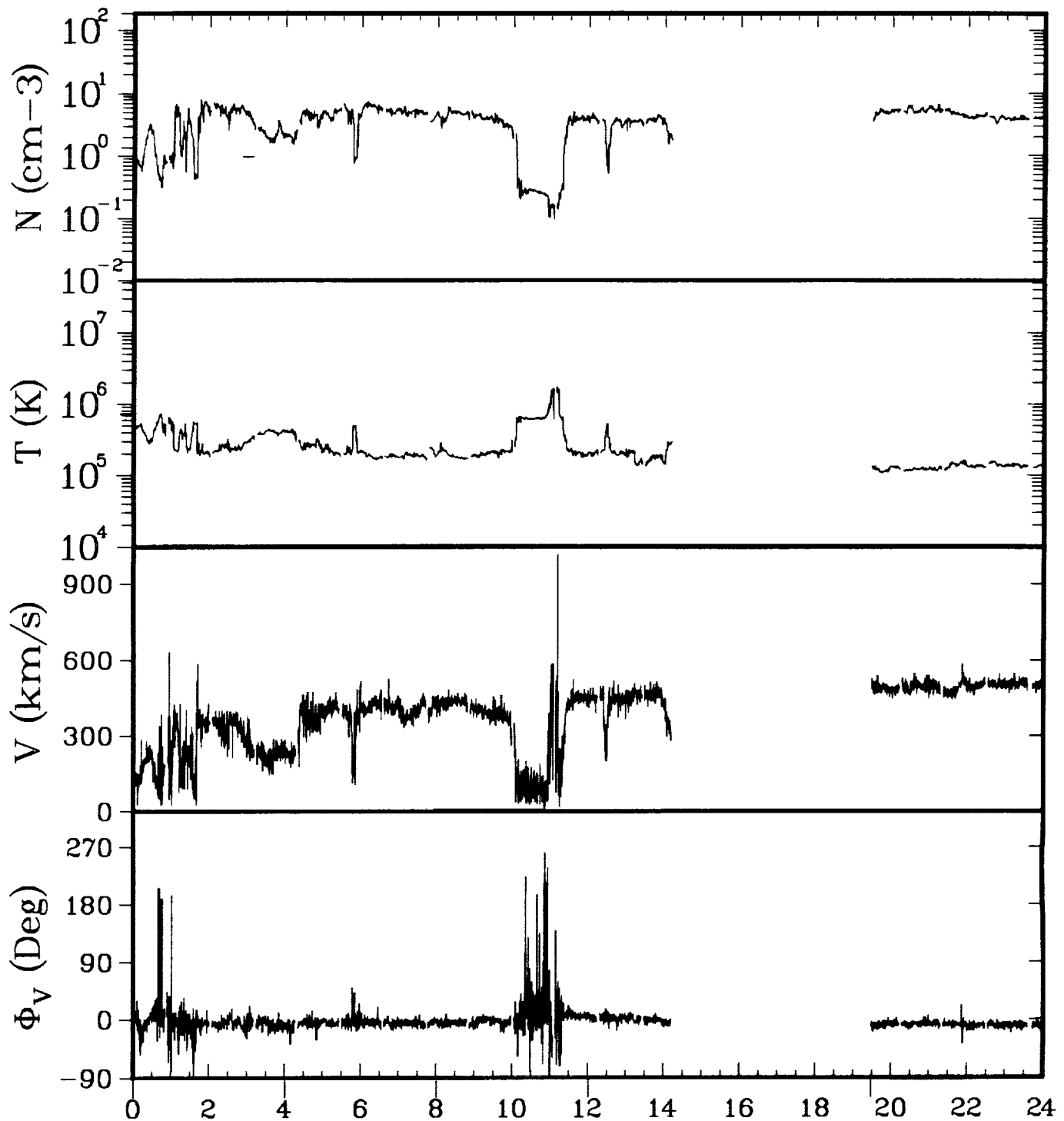

ISEE-3 ELECTRONS 08/20/83

GSEX	-208.4	-208.2	-207.9	-207.7	-207.3
Y	5.5	5.3	5.1	4.9	4.6
Z	20.6	20.6	20.7	20.7	20.8
GSMY	8.6	11.4	14.5	15.0	8.7
Z	19.5	18.0	15.6	15.1	19.5

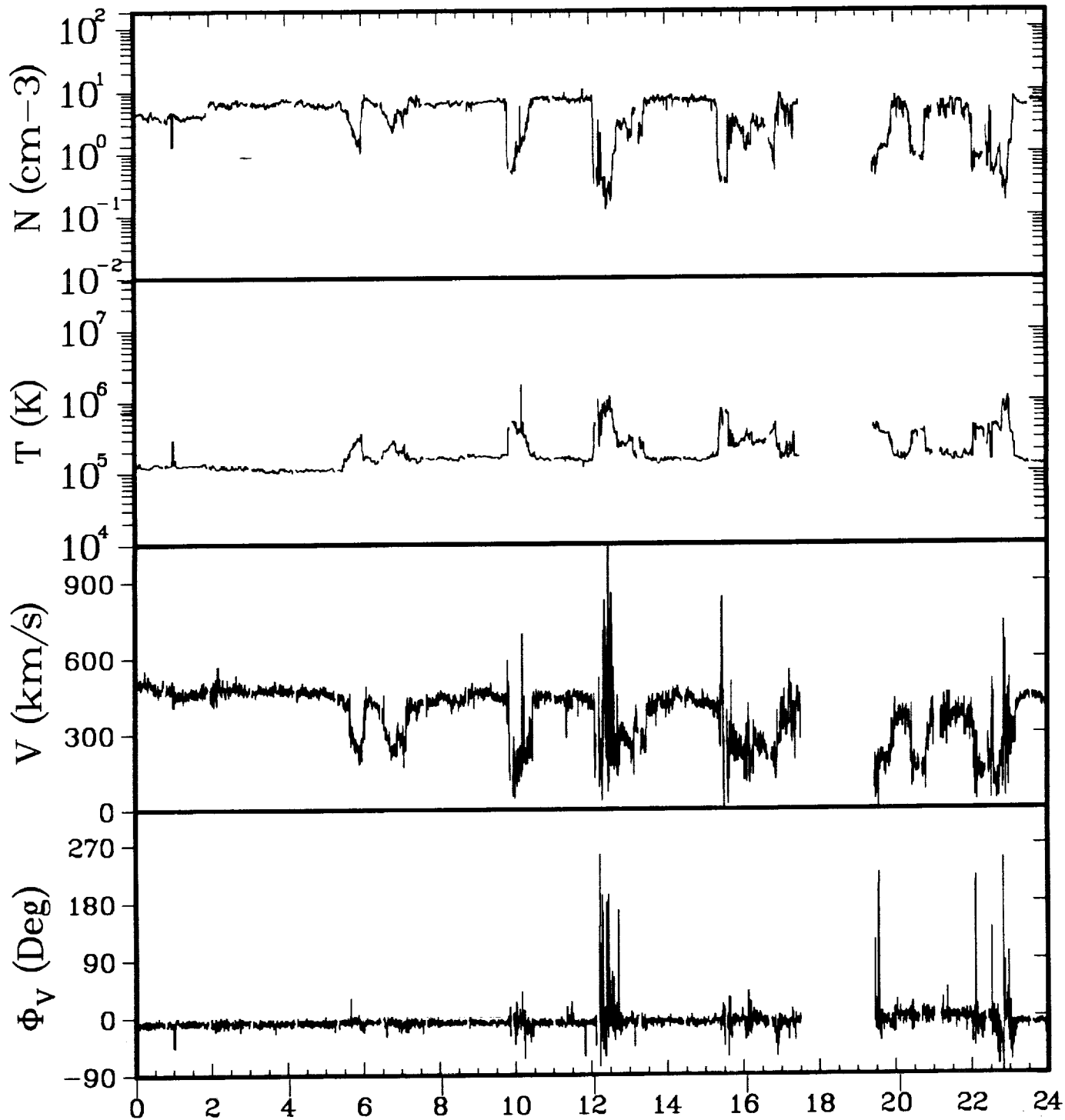

ISEE-3 ELECTRONS 08/21/83

GSEX	-207.0	-206.8	-206.5	-206.3	-206.0	-205.8
Y	4.3	4.1	3.9	3.7	3.5	3.3
Z	20.9	20.9	21.0	21.0	21.0	21.1
GSMY	7.5	10.5	13.7	14.2	11.2	7.1
Z	20.0	18.6	16.4	15.9	18.2	20.1

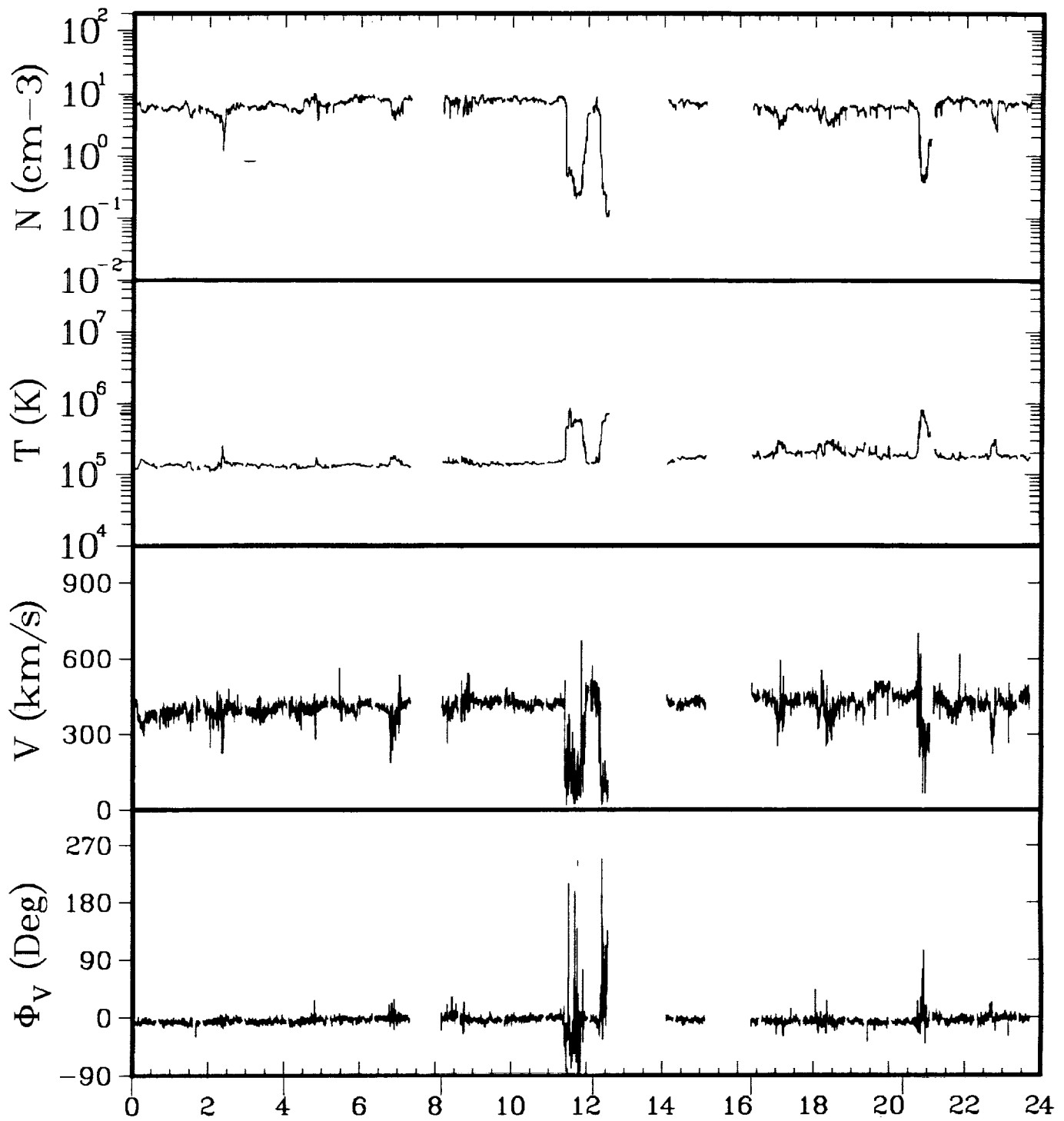

ISEE-3 ELECTRONS 08/22/83

GSEX	-205.6	-205.3	-205.0	-204.8	-204.5	-204.3
Y	3.1	2.9	2.7	2.5	2.2	2.0
Z	21.1	21.2	21.2	21.2	21.3	21.3
GSMY	6.4	9.4	12.8	13.3	9.8	5.8
Z	20.4	19.2	17.1	16.8	19.0	20.6

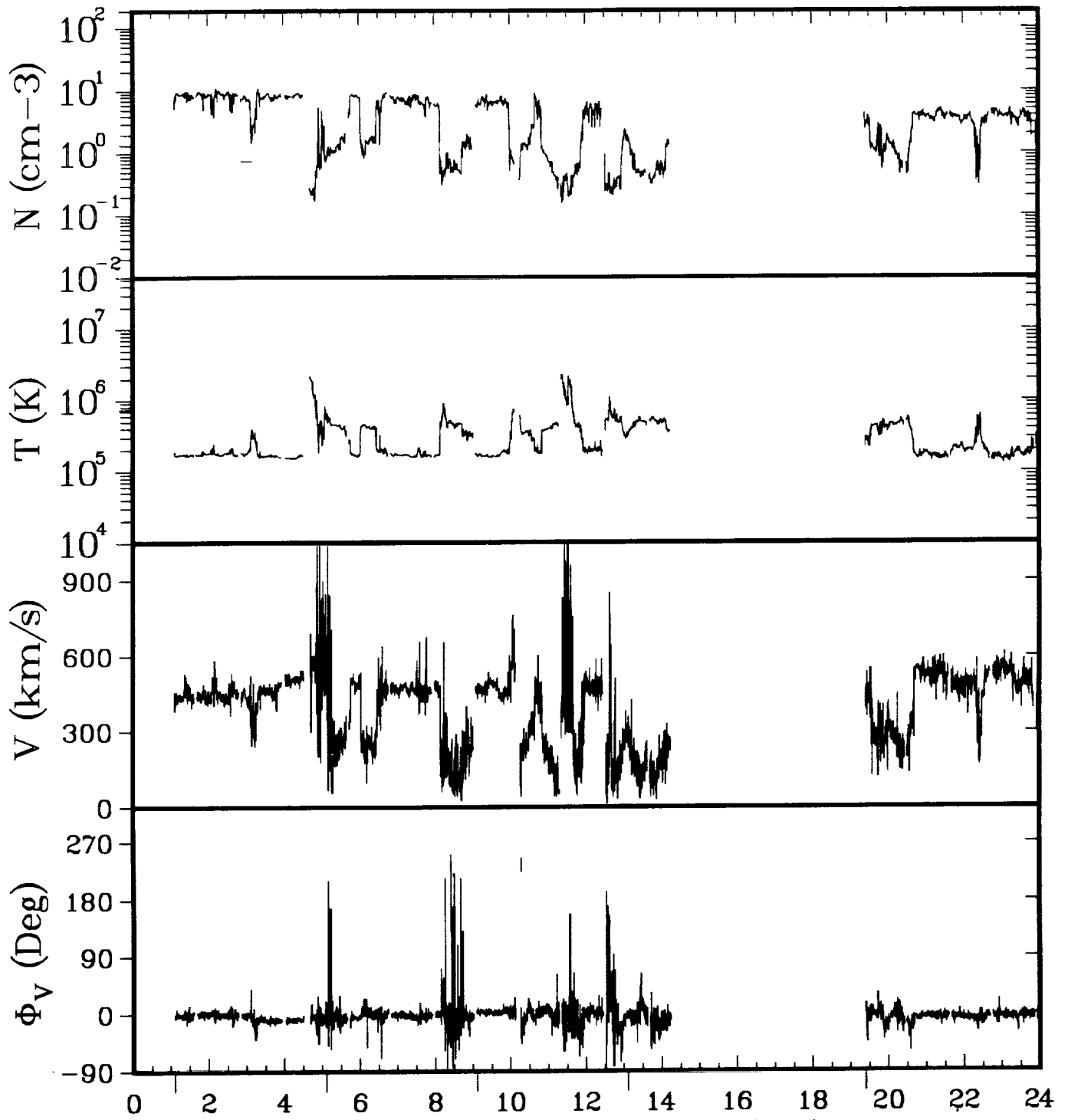

ISEE-3 ELECTRONS 08/23/83

GSEX	-203.9	-203.7	-203.4	-203.1	-202.7
Y	1.8	1.5	1.3	1.1	0.7
Z	21.4	21.4	21.4	21.4	21.5
GSMY	5.8	9.4	12.3	11.8	5.3
Z	20.6	19.3	17.6	17.9	20.8

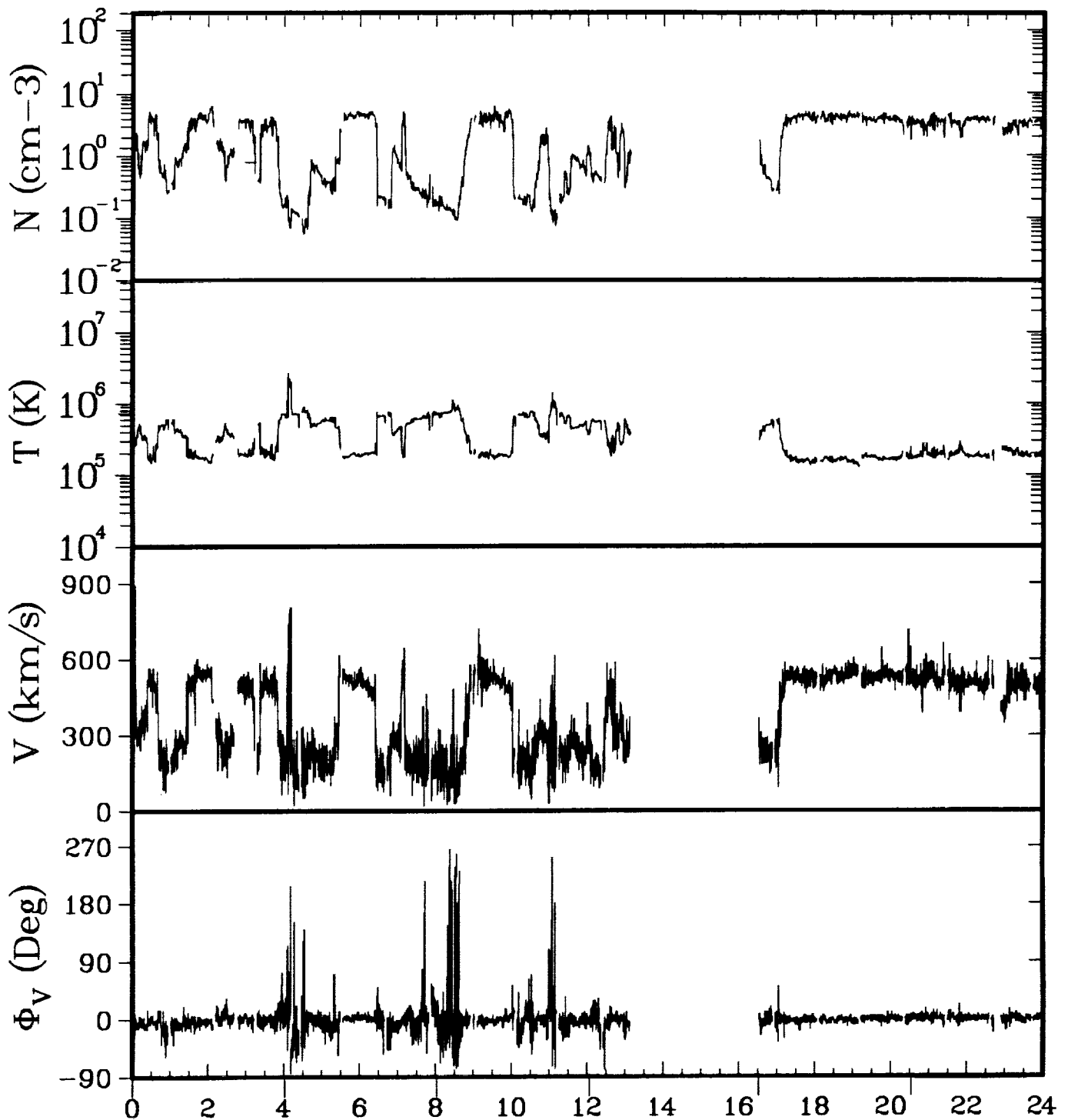

ISEE-3 ELECTRONS 08/24/83

GSEX	-202.4	-202.1	-201.8	-201.5	-201.2	-200.9
Y	0.5	0.2	0.0	-0.2	-0.5	-0.7
Z	21.5	21.6	21.6	21.6	21.6	21.7
GSMY	4.0	7.1	10.7	11.3	7.3	3.1
Z	21.2	20.3	18.7	18.4	20.4	21.4

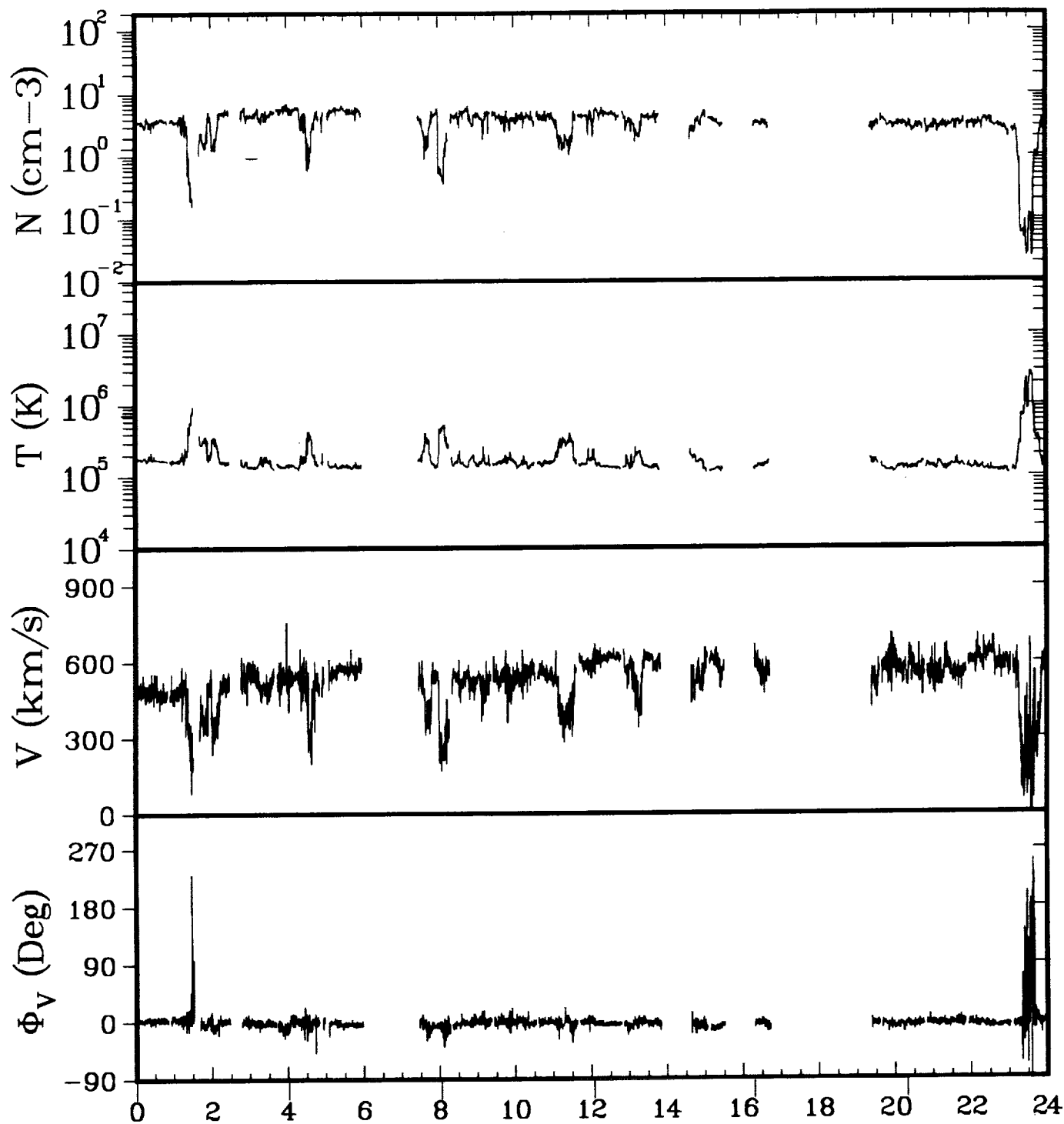

ISEE-3 ELECTRONS 08/25/83

GSEX	-200.6	-200.3	-200.0	-199.7	-199.4	-199.1
Y	-0.9	-1.2	-1.4	-1.7	-1.9	-2.2
Z	21.7	21.7	21.7	21.7	21.8	21.8
GSMY	2.7	5.9	9.6	10.2	6.4	1.9
Z	21.5	20.9	19.5	19.3	20.9	21.8

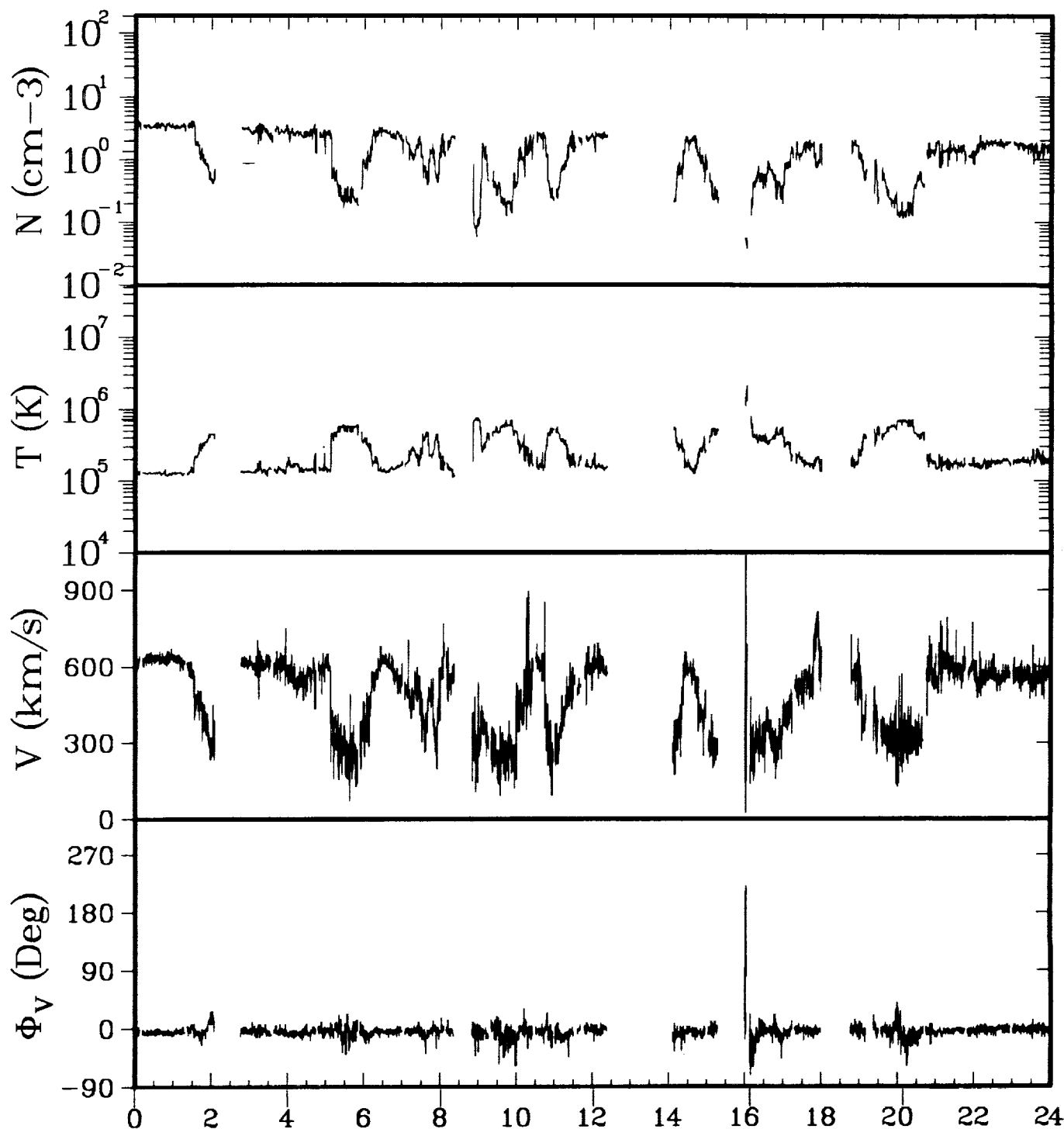

ISEE-3 ELECTRONS 08/26/83

GSEX	-198.8	-198.5	-198.2	-197.8	-197.5	-197.2
Y	-2.4	-2.7	-2.9	-3.2	-3.4	-3.7
Z	21.8	21.8	21.8	21.8	21.9	21.9
GSMY	1.4	4.6	8.5	9.1	5.3	0.7
Z	21.9	21.5	20.3	20.1	21.5	22.2

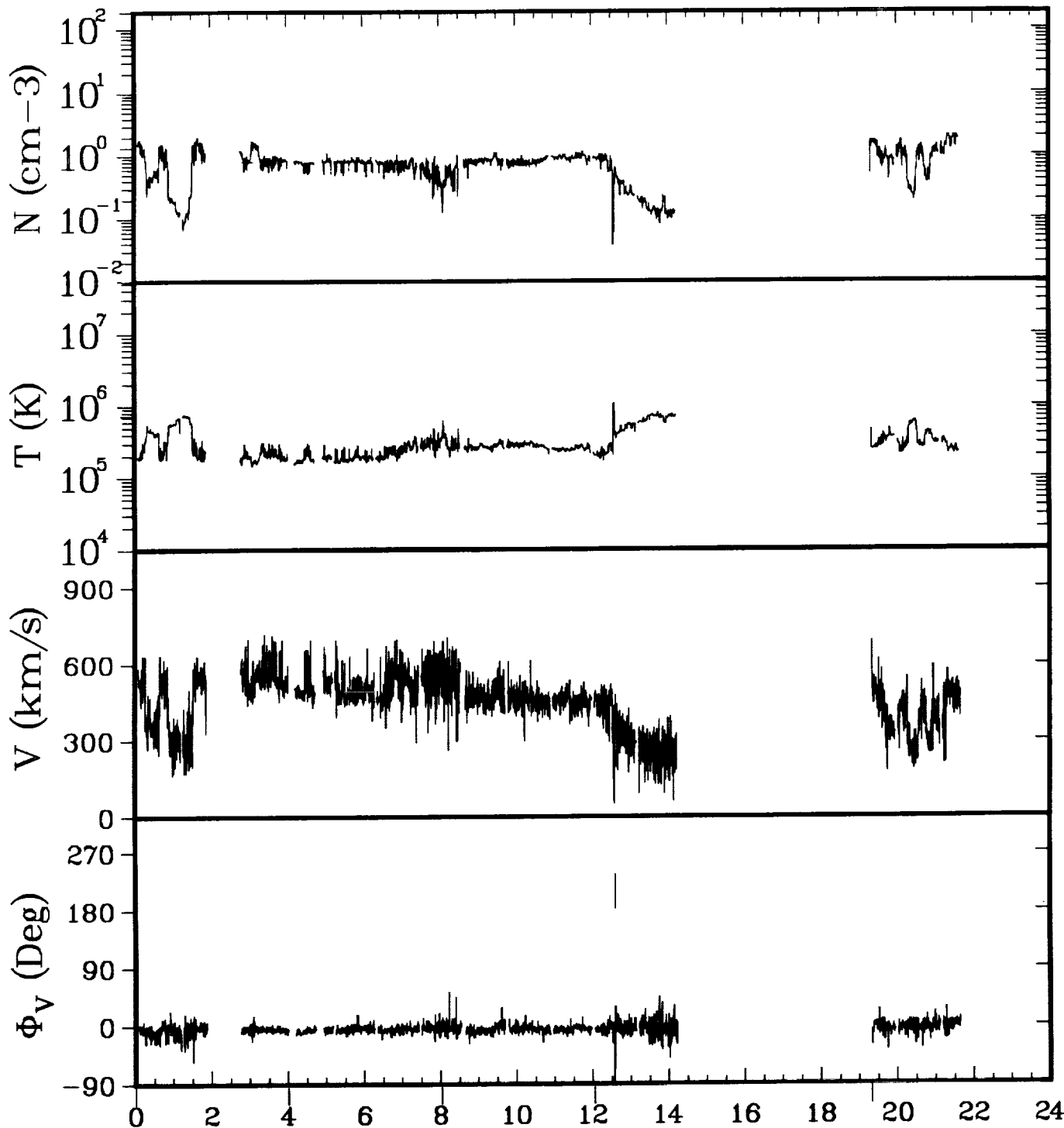

ISEE-3 ELECTRONS 08/27/83

GSEX	-196.9	-196.5	-196.2	-195.8	-195.2
Y	-3.9	-4.2	-4.4	-4.7	-5.1
Z	21.9	21.9	21.9	21.9	21.9
GSMY	0.0	3.3	7.3	7.8	0.0
Z	22.2	22.0	21.1	21.0	22.5

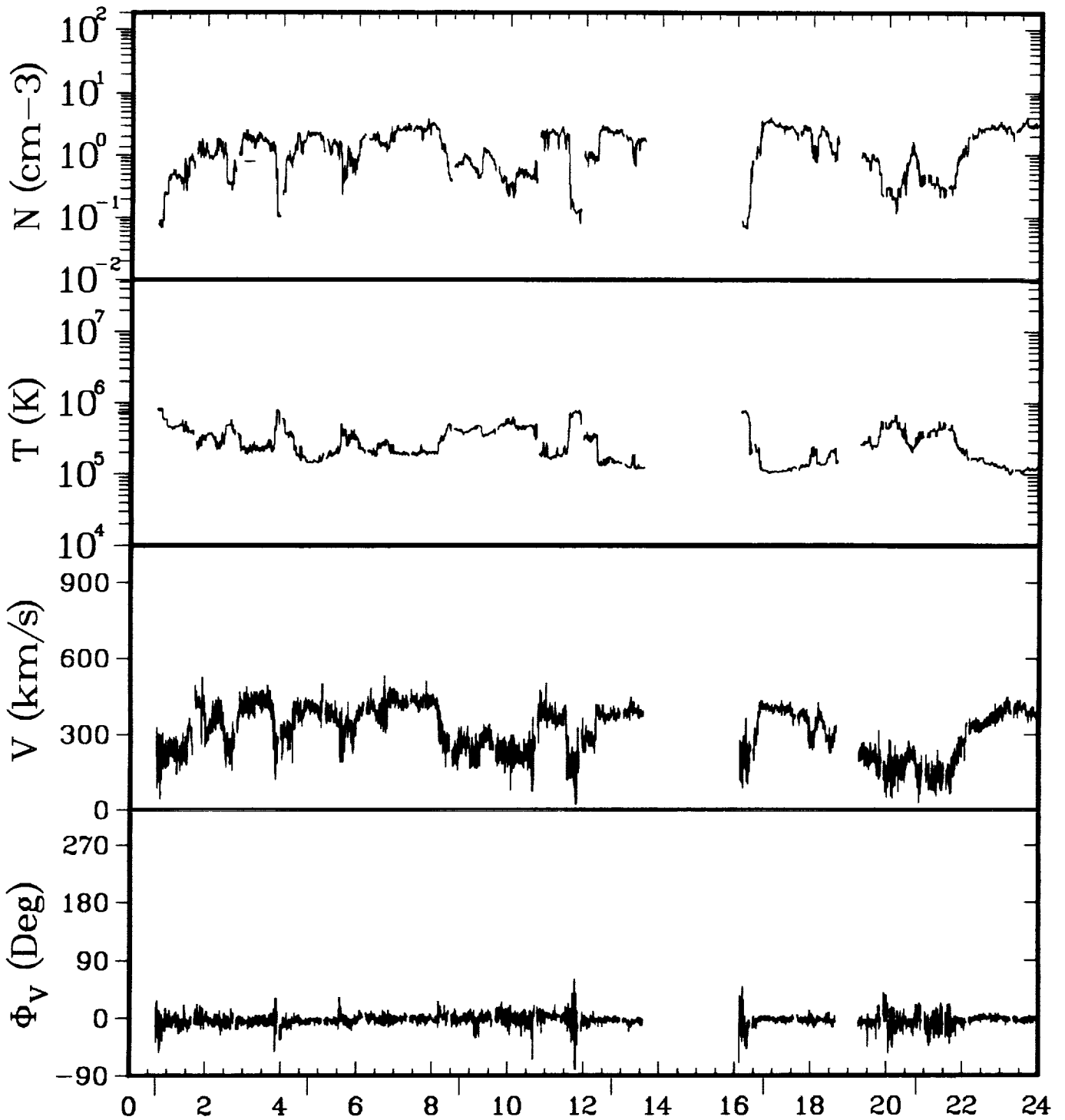

ISEE-3 ELECTRONS 08/28/83

GSEX	-194.7	-194.4	-194.0	-193.7	-193.3	-192.9
Y	-5.5	-5.8	-6.0	-6.3	-6.6	-6.8
Z	21.9	21.9	21.9	21.9	21.9	21.9
GSMY	-1.1	2.7	6.4	6.2	1.7	-2.7
Z	22.6	22.5	21.8	21.9	22.8	22.8

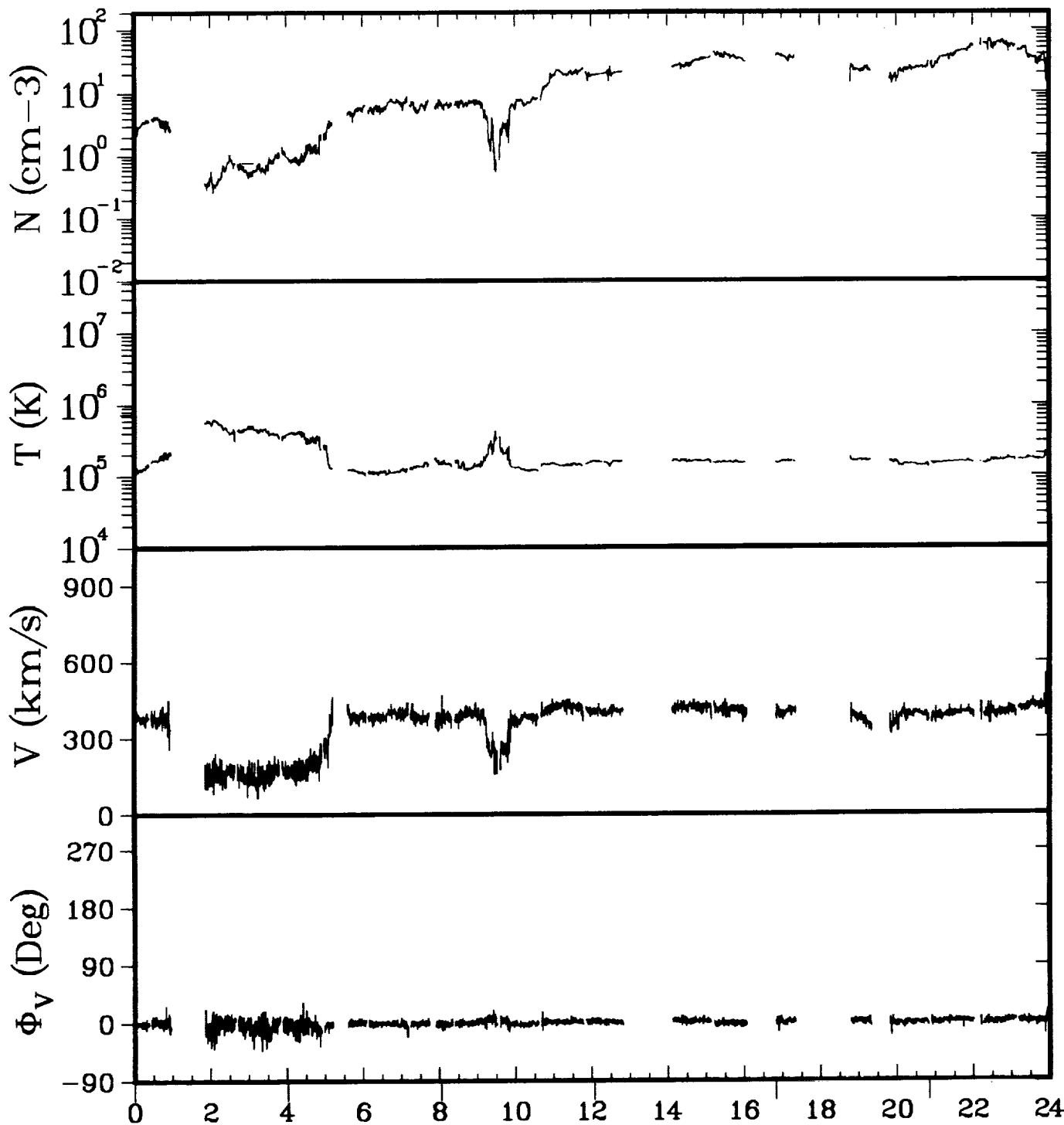

ISEE-3 ELECTRONS 08/29/83

GSEX	-192.6	-192.3	-191.9	-191.5	-191.1	-190.7
Y	-7.0	-7.3	-7.6	-7.8	-8.2	-8.4
Z	21.9	21.9	21.9	21.9	21.9	21.9
GSMY	-3.0	0.5	4.7	5.3	0.2	-4.2
Z	22.8	23.1	22.7	22.7	23.4	23.1

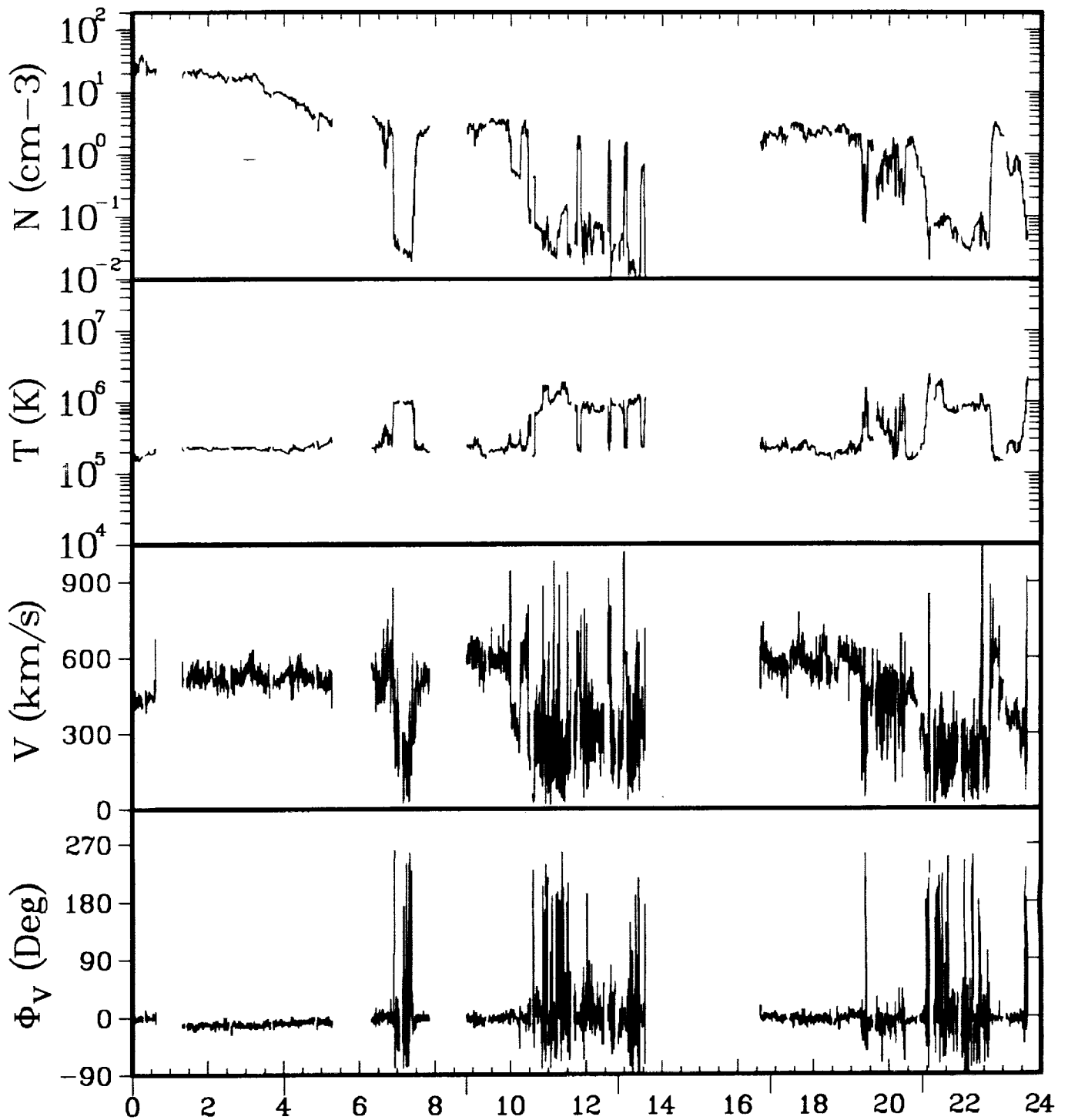

ISEE-3 ELECTRONS 08/30/83

GSEX	-190.4	-190.0	-189.5	-189.1	-188.7	-188.3
Y	-8.6	-8.9	-9.2	-9.5	-9.8	-10.1
Z	21.9	21.9	21.9	21.9	21.8	21.8
GSMY	-4.5	-1.0	3.8	3.5	-1.4	-5.8
Z	23.1	23.6	23.4	23.6	23.9	23.3

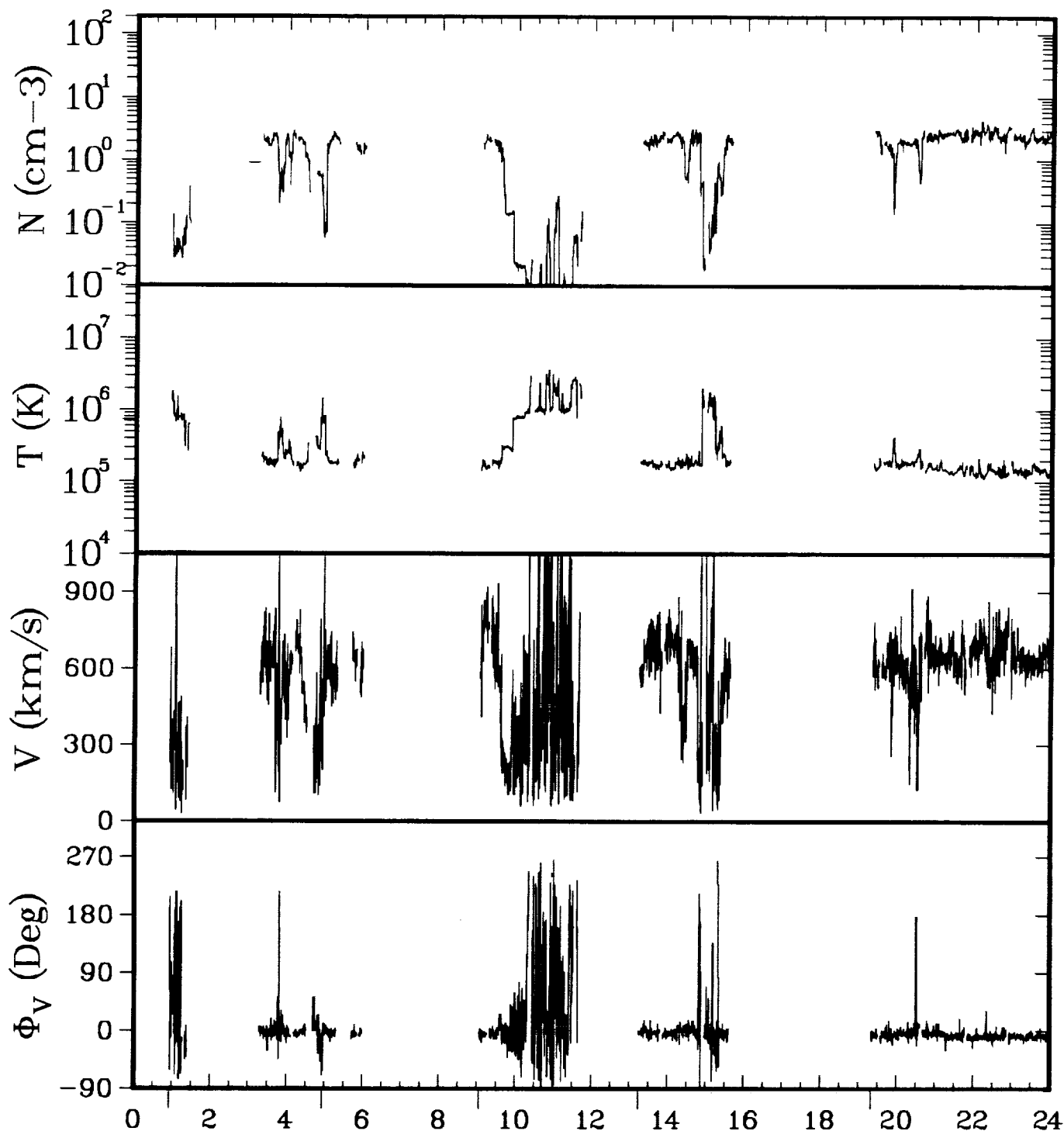

ISEE-3 ELECTRONS 08/31/83

GSEX	-187.9	-187.5	-187.1	-186.6	-186.0
Y	-10.3	-10.6	-10.9	-11.2	-11.6
Z	21.8	21.8	21.8	21.8	21.7
GSMY	-5.5	-1.3	2.6	1.8	-6.1
Z	23.5	24.2	24.2	24.4	23.9

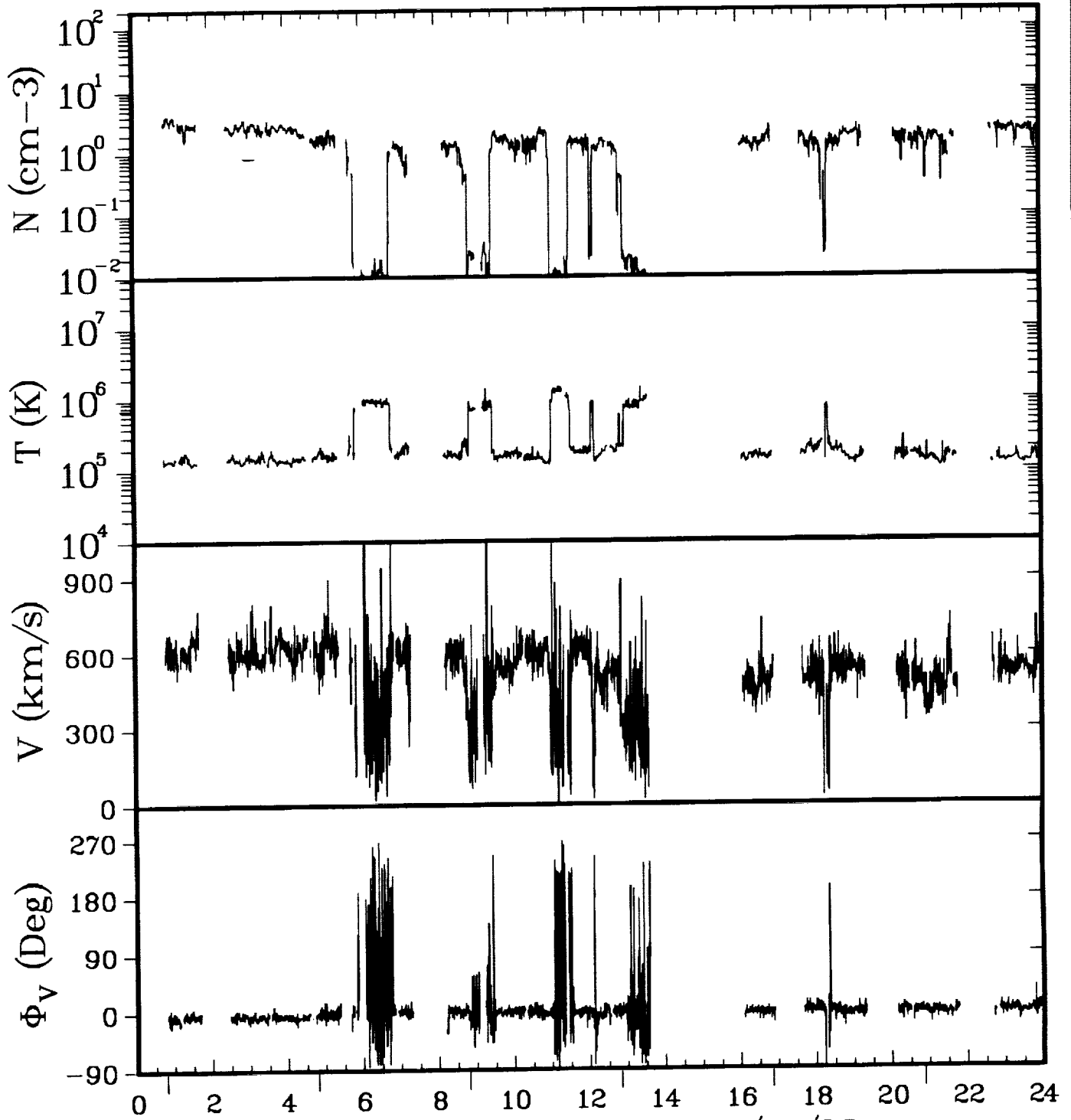

ISEE-3 ELECTRONS 09/01/83

GSEX	-185.4	-185.0	-184.6	-184.1	-183.7	-183.3
Y	-12.0	-12.3	-12.5	-12.8	-13.1	-13.4
Z	21.7	21.7	21.6	21.6	21.6	21.6
GSMY	-7.2	-3.0	1.0	0.6	-4.4	-9.0
Z	23.7	24.7	25.0	25.1	24.9	23.7

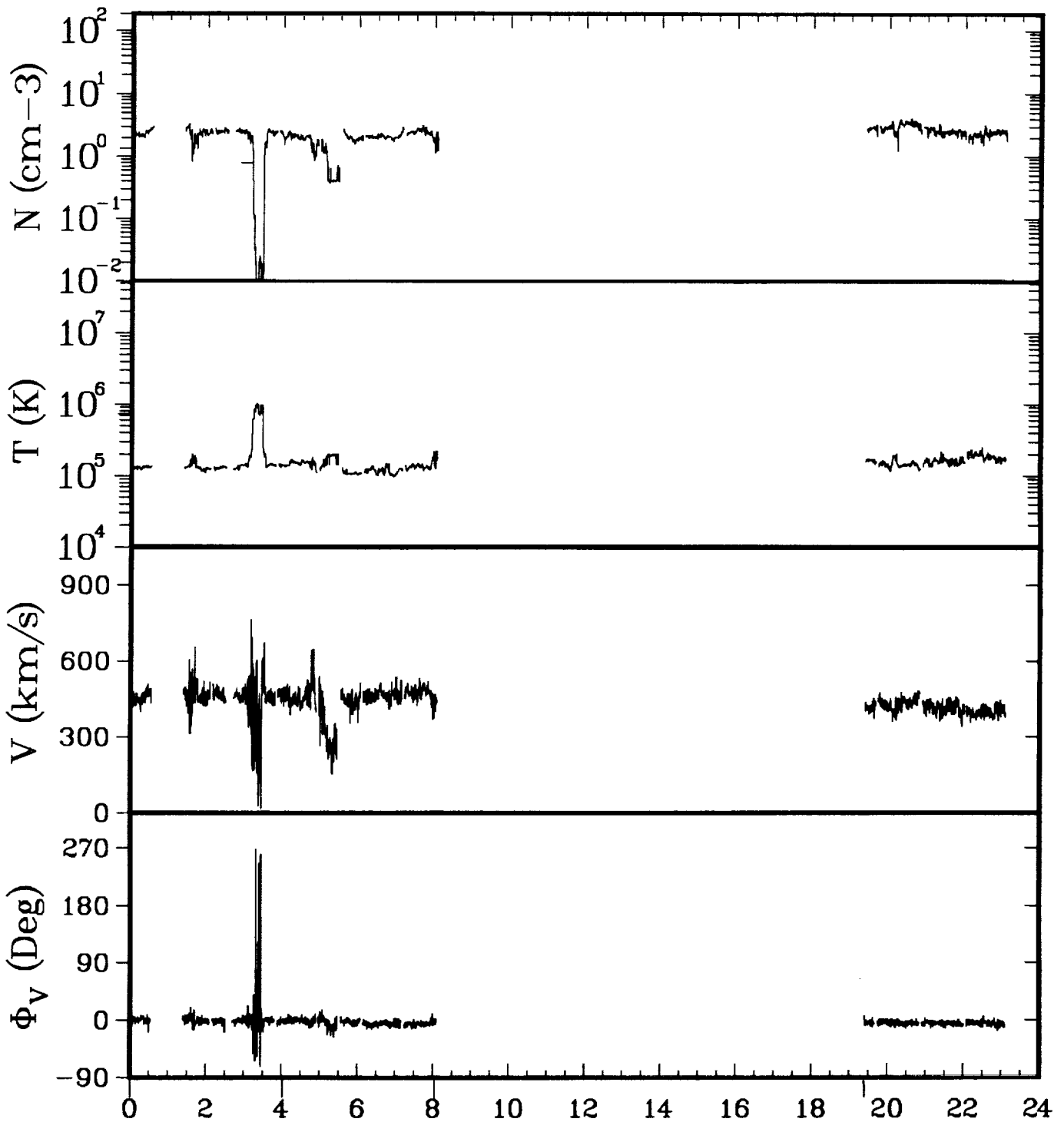

ISEE-3 ELECTRONS 09/03/83

GSEX	-180.2	-179.7	-999.0	-999.0
Y	-15.3	-15.6	-999.0	-999.0
Z	21.3	21.3	-999.0	-999.0
GSMY	-10.9	-7.2	-999.0	-999.0
Z	23.9	25.4	-999.0	-999.0

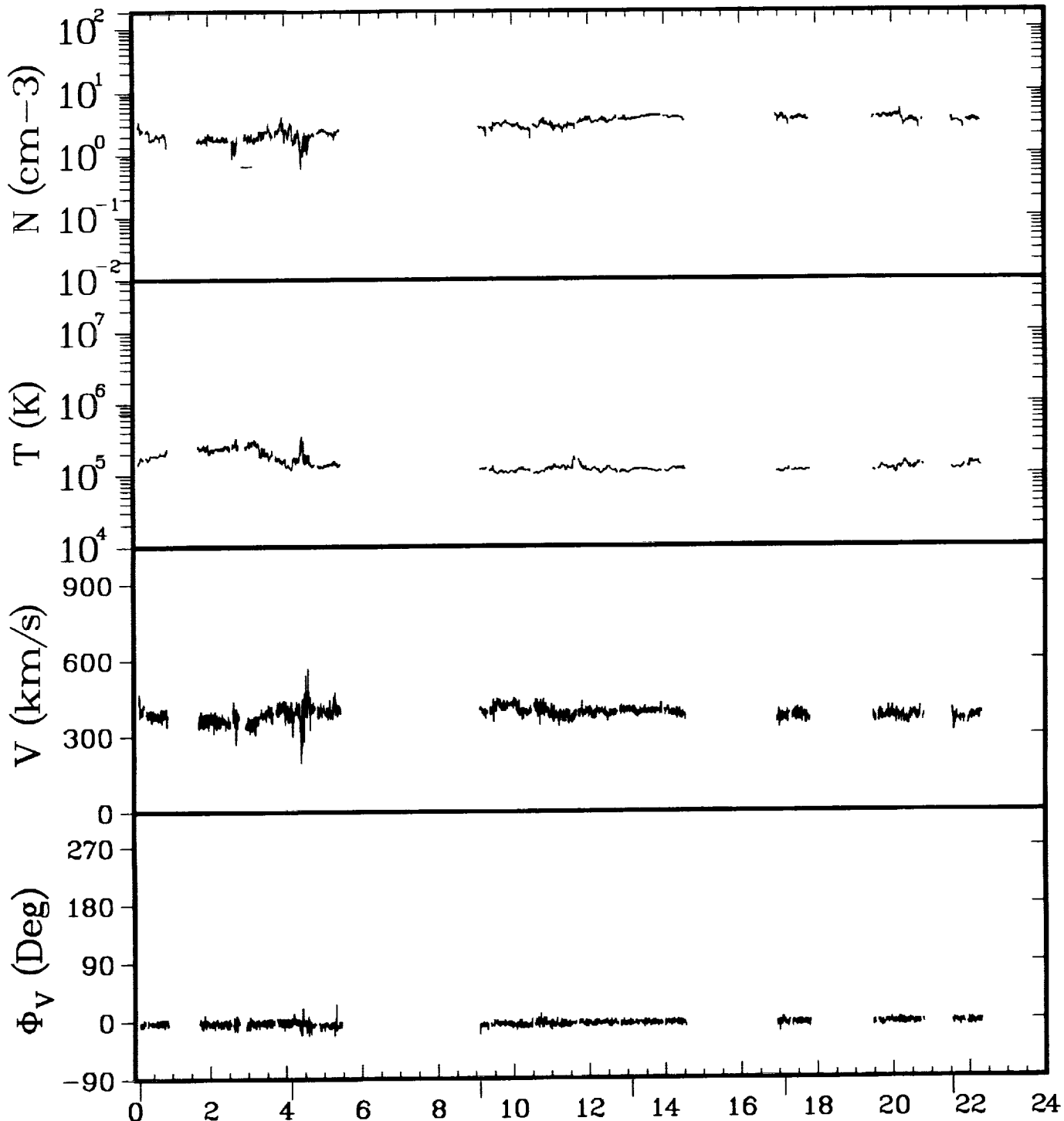

ISEE-3 ELECTRONS 09/04/83

GSEX	-999.0	-176.9	-176.3	-175.8	-175.3	-174.8
Y	-999.0	-17.4	-17.7	-18.0	-18.3	-18.7
Z	-999.0	21.0	21.0	20.9	20.9	20.8
GSMY	-999.0	-8.7	-3.3	-4.2	-9.8	-14.4
Z	-999.0	25.8	27.3	27.3	26.0	23.9