

10-8-11  
E 6279

NASA  
Technical Memorandum 104441  
AIAA-91-2355

AVSCOM  
Technical Report 91-C-029

# Jet-A Reaction Mechanism Study for Combustion Application

Chi-Ming Lee and Krishna Kundu  
*Lewis Research Center  
Cleveland, Ohio*

and

Waldo Acosta  
*Propulsion Directorate  
U.S. Army Aviation Systems Command  
Lewis Research Center  
Cleveland, Ohio*

Prepared for the  
27th Joint Propulsion Conference  
cosponsored by the AIAA, SAE, ASME, and ASEE  
Sacramento, California, June 24-27, 1991

**NASA**



# JET-A REACTION MECHANISM STUDY FOR COMBUSTION APPLICATION

Chi-Ming Lee and Krishna Kundu  
National Aeronautics and Space Administration  
Lewis Research Center  
Cleveland, Ohio 44135

and

Waldo Acosta  
Propulsion Directorate  
U.S. Army Aviation Systems Command  
Lewis Research Center  
Cleveland, Ohio 44135

## ABSTRACT

Simplified chemical kinetic reaction mechanisms for the combustion of Jet A fuel are studied. Initially 40 reacting species and 118 elementary chemical reactions were chosen based on the literature review of previous works. Through a sensitivity analysis with the use of LSENS General Kinetics and Sensitivity Analysis Code, 16 species and 21 elementary chemical reactions were determined from this study. This mechanism is first justified by comparison of calculated ignition delay time with available shock tube data, then it is validated by comparison of calculated emissions from plug flow reactor code with in-house flame tube data.

## INTRODUCTION

A successful modeling of combustion and emissions of gas turbine engine combustors requires an adequate description of the reaction mechanism. For hydrocarbon oxidation, detailed mechanisms are only available for the simplest types such as methane, ethane, acetylene, ethylene, and propane.<sup>1,2</sup> These detailed mechanisms contain a large number of chemical species participating simultaneously in many elementary kinetic steps. Current computational fluid dynamics (CFD) models involve chemical reactions, turbulent mixing, fuel vaporization, and complicated boundary geometries, etc. To simulate these conditions requires a sophisticated computer code, which usually requires a large memory capacity and take a long time to simulate. To get around these problems, the gas turbine combustion modeling effort has frequently been simplified by using a global approach that reduces chemistry to the specification of an overall global reaction mechanisms, which can predict quantities of interest: heat release rates, flame temperature, emissions, and ignition delay time.

The simplest Jet-A reaction mechanism is the one-step mechanism:

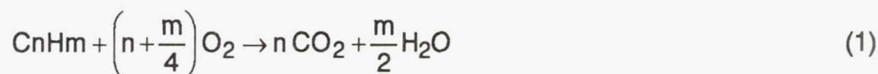

where the coefficients  $n$ ,  $m$  are the carbon to hydrogen ratio. The advantage of this mechanism is its simplicity; it involves the solution of the conservation equations for unburned fuel and mixture fraction, the heat release and other species concentrations are obtained from linear functions of the amount of fuel consumed. This mechanism, however, fails to predict the important characteristics of Jet-A oxidation, i.e., the formation of intermediates and CO. As a result, this mechanism overpredicts the heat of reaction, hence higher adiabatic flame temperatures.

A slightly more complex mechanism is the two-step mechanism proposed by Edelman and Fortune:<sup>3</sup>



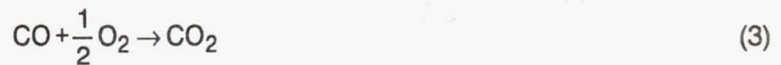

This involves one global reaction describe the formation of CO and H<sub>2</sub>O, and a second global reaction describe the formation of CO<sub>2</sub>. However the formation of intermediates is still ignored and so this mechanism cannot predict the time delay between the initial disappearance of fuel into intermediates and a significant rise in temperature.

The objective of this study is to define a mechanism that can explain most of the observed phenomena in our flame tube experiment. The proposed mechanism involves 16 species and 21 elementary reactions. The initial breakdown of the fuel molecule has been assumed to be the reaction of the fuel molecule with oxygen; the chain carriers are CH<sub>2</sub>, O and OH radicals, assumed Jet-A structure is C<sub>13</sub>H<sub>27</sub>: Initiation:



These important steps in the chain propagation are:

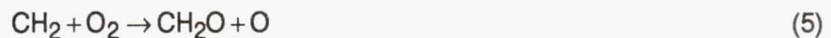

The species CH<sub>2</sub> has been considered here as a representative of unburned hydrocarbon fragments. The importance of this specie increases with increase in fuel concentration. The above reaction steps have been combined with the existing mechanism of hydrogen—air oxidation reported by Nguyen and Bittker,<sup>4</sup> some reaction rates were replaced by more recent values reported by Miller.<sup>5</sup> The activation energy used for Jet-A oxidation was close to the value reported by Freeman.<sup>6</sup> The proposed mechanism is listed in Table 1.

The proposed mechanism was first examined through a sensitivity analysis with the use of in-house Sensitivity Analysis Program Code, the orders of importance for the species of interest and classification of reactions in descending order of importance are determined. The resulting mechanism was then validated by calculated ignition delay time with experimental ignition delay time. Then using this mechanism to calculate results from plug flow reactor code were verified with in-house experimental flame tube data.

## EXPERIMENTAL APPARATUS AND PROCEDURE

### Test Facility

The combustor was mounted in Stand 2 of the test facility CE5B located in the Engine Research Building (building 5) at NASA Lewis. Tests were conducted with combustion inlet air pressure ranging up to 16 atm with the air indirectly heated to about of 811 K (1000 °F). The temperature of the air was controlled by mixing the heated air with varying amounts of cold by-pass air. Air flow through the heat exchanger and by-pass flow system and the total pressure of the combustor were regulated by remotely controlled valves.

### Test Rig

The high pressure and temperature test section used in this experiment consisted of an inlet section, fuel injection and vaporization section, flame holder, and combustion section. The combustion test rig is illustrated schematically in Fig. 1. The flow area is square having an area of 58 cm<sup>2</sup> (9 in.<sup>2</sup>). The premixing and vaporization section, and the combustion section were 27 cm (10.5 in.) and 74 cm (29 in.) long, respectively. The rig is designed to allow changes in the mixing and vaporization lengths.

## Fuel Injector

Jet-A fuel was introduced into the airstream by means of a multiple-passage fuel injector shown in Fig. 2. The fuel injector was designed to provide a good dispersion of fuel in the air stream by injecting equal quantities of fuel into each of the individual air passages. The injector used in these tests had 16 square passages. Each passage was machined to form a converging diverging flow path. The 64 percent blockage helped to insure a uniform velocity profile over the duct cross section. The pressure drop ranged between 3 and 6 percent of the inlet pressure.

Fuel was discharged from 16.5 cm (6.5 in.) long, 0.7 mm (0.027 in.) diameter tubes into the converging upstream end of each of the air passages. The fuel tubes were routed through a 0.32 cm (0.125 in.) diameter feedthru hole. The feedthru holes were routed through a plenum, and the plenum was air cooled to prevent the fuel from heating and coking within the tubes. The cooling air was discharged into the main airstream. The cooling air amounted to about 5 percent of the total air flow.

## Flame Holder

The flame holder assembly is shown in Fig. 3. The flame holder is a water-cooled perforated plate. The flame holder was made by brazing 36 tubes of 0.63 cm (0.25 in.) inside diameter between two cooper nickel beryllium alloy plates. This resulted in an open area of 20 percent of the inlet duct cross-sectional area. The total pressure drop across the burner ranged from 5 to 12 percent of inlet air pressure depending on the operating conditions.

## Test Section

The water cooled combustion section had a square cross-section like the inlet section and was 74 cm (29 in.) long, because of availability. At the downstream end quench water was sprayed into the gas stream to cool the exhaust. A cross section schematic of the combustor is shown in Fig. 4. The flow path was casted in place by using a high temperature castable refractory material. A high temperature insulating ceramic fiber paper was placed between the hard refractory material and the stainless steel water cooled housing. The paper served two purposes, first to reduce the heat loss and minimize cold-wall effects, and second to compensate for the difference in thermal expansion between the ceramic and the housing.

## Instrumentation

The combustion gases were sampled with six water-cooled sampling probes located at the axial positions shown in Fig. 1, 10.2, 30.5, and 50.8 cm (4, 12, and 20 in.) downstream of the flame holder. There were two probes at each axial location, 1.57 cm (0.62 in.) from the center line. The probes were 1.57 cm (0.62 in.) in diameter with five 1 mm (0.040 in.) diameter sampling tubes manifolded together. Remotely operated solenoid sampling valves permitted the selection of the sample gas from one probe at a time. The probes were mounted on pneumatic operated cylinders interconnected with the solenoid sampling valves so that only one probe was in the airstream at a time.

In addition to gas analysis, pressure and temperatures were measured along the test rig. At the exit of the bellmouth, a rake containing five total pressure probes and a wall static tap were used to determine the air velocity profile. The inlet temperature was measured with two thermocouples at the inlet to the rig. Pressure and temperature were also measured upstream of the flame holder to determine the presence of upstream burning and the fuel injector pressure drop. The temperature of the combustion gases was measured using a Type B thermocouple located approximately 40.6 cm (16 in.) downstream of the flame holder. A pressure tap at the exit of the combustor was used to calculate the combustor pressure drop.

The fuel used for this work is specified by ASTM Jet-A turbine fuel designation. This is a multicomponent kerosene type fuel commonly used in gas turbine engines. Jet-A with a H/C ratio of 1.96, was metered to the reactor from a pressurized fuel tank. Flow rates measured with a calibrated turbine flow meter were varied from 0.1 to 4.0 GPM, depending on the equivalence ratio desired.

Standard procedures were followed for each run. These included a warm-up of at least 2 hr with 1000 to 1100 °F hot air to the desired test conditions. This procedure assure steady-state temperature in the reactor. After the reactor reached a steady-state temperature, start-up was initiated by adding fuel to the hot air and igniting the mixture with a spark igniter. Gas samples were drawn sequentially from one of the six probes, sample gases then were passed through the following analyzers: nondispersive infrared carbon monoxide, carbon dioxide, and hydrocarbon units, a chemiluminescent nitrogen oxides unit, and an electrochemical oxygen unit. Each analyzer unit was zeroed and calibrated with known concentration gas prior to test run.

## COMPARISONS OF PROPOSED MECHANISM WITH EXPERIMENTAL DATA

The worth of any reaction mechanisms is determined by its ability to predict experimental data from various sources. This section evaluates the proposed Jet-A mechanisms with chemical equilibrium calculation, ignition delay times, and in-house flame tube experimental data.

### Equilibrium Calculation

The combustion mechanism we started with had 118 reaction steps and 40 reacting species, but it could be divided into three parts (1) oxidation and breakdown of the fuel; (2) hydrogen-oxygen reaction; and (3) oxidation of carbon monoxide. To reduce the size of the mechanism, the important reaction steps were computed by sensitivity analysis. Normalized sensitivity coefficients were computed using decoupled direct method reported by Radhakrishnan.<sup>7</sup>

In the present work sensitivity coefficients of several species concentrations plus temperature and pressure were used to determine important reactions.

The predictions of sensitivity calculations were tested by indirect methods. The rate constants for individual reactions were changed and the ignition delay calculations were repeated. Using this technique, a few steps which were not very important in the fuel-lean combustion, were eliminated.

This mechanism was further tested by comparing the computed combustion temperature and the concentrations of different species with those obtained by using chemical equilibrium code.<sup>8</sup> Table 2 shows that the predictions of temperature and species concentration by using present mechanism agree very well with the results from chemical equilibrium calculation. The proposed mechanism has reduced to 16 species and 21 reaction steps.

### Ignition Delay Time

The ignition delay time was defined at those corresponding to the advent of significant increase in temperature and pressure. Figure 5 shows the calculated ignition delay time for Jet-A and air is 36 msec. This calculation is performed by in-house shock tube code integrated with the proposed mechanism. The experimental data of Jet-A ignition delay times were taken from Freeman and Lefebure's<sup>6</sup> work for equivalence ratio of 0.5. Figure 6 shows very good agreement between computed results and experimental data.

### Flame Tube Experiment

Jet-A fuel has been studied over the equivalence ratio range 0.471 to 0.588 ( $F/A=0.032$  to  $0.040$ ), with inlet air maintained at 1000 °F (810 K). Adiabatic flame temperature ranging from 2940 to 3265 °F (1889 to 2069 K).

The Jet-A fuel is pre-mixed with air and prevaporized, so that transport effect can be neglected. The amount of fuel injected is less than 1 percent on a molar basis, and the inlet air flow is highly turbulent, thus, the effects of longitudinal diffusion of mass and energy are negligible. The reactor is insulated with ceramic material, as a result, the reactor can be characterized as one-dimensional adiabatic plug flow reactor.

The concentrations of CO and CO<sub>2</sub> were recorded at three probe locations; the temperature was recorded at a location between probe 2 and probe 3. The combustion was practically 99 percent complete at all three locations, based on emission data.

Since an ignitor was used to start combustion, it was very difficult to identify the zero time of reaction in plug flow type calculations, we assumed the time of reaction started at the ignitor.

Figures 7 to 9 shows CO, CO<sub>2</sub>, and flame temperature plotted against equivalence ratio. Judging from these figures, it appears that the experimentally measured CO<sub>2</sub> concentrations were consistently higher than computed, it is possible that there was an air leak in the system, as a result the actual equivalence ratio was higher than what used in the computation. The computed flame temperatures was also slightly higher than the experimental results. It is possible because of an air leak in the system, in addition, the thermocouples were installed about 1/8 in. into the flame tube wall, it could be affected by boundary layer temperature. This mechanism explains that carbon monoxide concentration increases with increase in equivalence ratio, but no quantitative correlation could be found.

### CONCLUSION

This work presents the results of fuel-lean combustion of Jet-A with inlet air temperature around 1100 °F and pressure around 10 atm. Combustion temperature and concentrations of CO and CO<sub>2</sub> at three probe locations have been reported.

A simplified mechanism to explain the experimental results, is also presented in this work. This mechanism has 21 steps of reactions and 16 reacting species; CH<sub>2</sub> is the only intermediate hydrocarbon fragment assumed in this mechanism. The equilibrium temperature and the concentration of species predicted by this mechanism, agrees very well with the results calculated by using equilibrium code by Gordon and McBride. Good agreement was found between the computed and experimental ignition delay times measured by Freeman and Lefebure over a considerable range of temperature.

This mechanism satisfactorily computes the in-house experimental combustion temperatures. The computed carbon dioxide concentrations also compare, satisfactorily with the experimental results. This mechanism explained the increased carbon monoxide concentration with increase in equivalence ratio, but no quantitative comparison could be made.

### References

1. Westbrook, C.K. and Pitz, W.J., "A Comprehensive Chemical Kinetic Reaction Mechanism for Oxidation and Pyrolysis of Propane and Propene," *Combustion Science and Technology*, Vol. 37, Nos. 3-4, 1984, pp. 117-152.
2. Jachimowski, C.J., "Chemical Kinetic Reaction Mechanism for the Combustion of Propane," *Combustion and Flame*, Vol. 55, Feb. 1984, pp. 213-224.
3. Edelman, R.B. and Fortune, O.F., "A Quasi-Global Chemical Kinetic Model for the Finite Rate Combustion of Hydrocarbon Fuels with Application to Turbulent Burning and Mixing in Hypersonic Engines and Nozzles," AIAA Paper 69-86, Jan 1969.
4. Nguyen, H.L., Bittker, D.A. and Niedzwiecki, R.W., "Investigation of a Low No<sub>x</sub> Staged Combustor Concept in High Speed Civil Transport Engines," AIAA Paper 89-2942, June 1988. (Also, NASA TM-101977).
5. Miller, J.A. and Bowman, C.T., "Mechanism and Modeling of Nitrogen Chemistry in Combustion," *Progress in Energy and Combustion Science*, Vol. 15, No. 4, 1989, pp. 287-338.
6. Freeman, G. and Lefebure, A.H., "Spontaneous Ignition Characteristics of Gaseous Hydrocarbon-Air Mixtures," *Combustion and Flame*, Vol. 58, Nov. 1984, pp. 153-162.
7. Radhakrishnan, K., "Decoupled Direct Method for Sensitivity Analysis in Combustion Kinetics," NASA CR-179636, 1987.
8. Gordon, S. and McBride, B.J., "Computer Program for Calculation of Complex Chemical Equilibrium Compositions, Rocket Performance, Incident and Reflected Shocks, and Chapman-Jouget Detonations," NASA-SP-273, 1971.

TABLE 1.—THE PROPOSED JET-A KINETIC MECHANISM\*

					A	B	E
H2	+	OH	=	H2O + H	4.74E+13	0.	6098.
H	+	O2	=	OH + O	1.89E+14	0.	16400.
O	+	H2	=	OH + H	4.20E+14	0.	13750.
H	+	O2	=	H02 + M	1.46E+15	0.	-1000.
THIRDBODY							
N2		3.0	O2	1.3	H2O	21.3	END
M	+	H2	=	H + H	2.20E+14	0.	96000.
M	+	O2	=	2.00	1.80E+18	-1.	118020.
H	+	H02	=	H2 + O2	2.20E+14	0.	2126.
H02	+	H	=	2.00H	4.24E+14	0.	1070.
H02	+	OH	=	H2O + O2	8.00E+12	0.	0.
CO	+	O2	=	CO2 + O	1.60E+13	0.	41000.
CO	+	OH	=	CO2 + H	1.51E+07	1.3	-758.
CO	+	H02	=	CO2 + OH	5.80E+13	0.	22930.
N	+	NO	=	N2 + O	3.27E+12	0.3	0.
O	+	NO	=	N + O2	3.80E+09	1.	41380.
O2	+	NO	=	N02 + O	1.00E+12	1.	45500.
N	+	OH	=	NO + H	3.80E+13	0.	0.
H	+	N02	=	NO + OH	3.00E+13	0.	0.
H02	+	NO	=	N02 + OH	2.11E+11	0.	-479.
O2	+	C13H27	>	13.CH2 + H02	6.00E+14	0.	42000.
CH2	+	O2	=	CH2O + O	2.00E+13	0.	9000.
M	+	CH2O	=	CO + H2	2.50E+14	0.	14595.

\* Forward reaction rate constants expressed as  $AT^B \exp(-E/RT)$ .  
 A= Frequency factor (cm-mol-s units)  
 B= Temperature coefficient (unitless)  
 E= Activation Energy (cal/mol)

TABLE 2.—CALCULATED RESULTS FROM EQUILIBRIUM CODE AND FROM THE PROPOSED MECHANISM

Species	Calculated by proposed mechanism (time = 1 sec)	Calculated by equilibrium code
CO	82 ppm	77 ppm
CO <sub>2</sub>	6.8 percent	6.8 percent
H <sub>2</sub>	18 ppm	18 ppm
Temperature	1985 K	1978 K

Initial mixture:

Equivalence ratio: 0.51, P = 9.53 atm, Tin = 841 K

TABLE 3.—SPONTANEOUS IGNITION DELAY TIMES FOR JET-A—AIR MIXTURE

initial mixture temperature (deg K)	ignition delay time		initial mixture temperature (deg K)	ignition delay time	
	experimental (ms)	calculation (ms)		experimental (ms)	calculation (ms)
LENGTH = 0.53 m					
1020.2	35	37	997.5	57	53
1010.9	40	42	993.0	61	58
1001.1	48	50	983.5	71	68
987.7	59	63	982.3	71	70
974.8	75	80	974.3	83	81
LENGTH = 1.22 m					
980.7	83	72	964.4	102	97
972.0	97	84	963.3	102	99
965.3	112	90	955.7	129	116
952.7	138	122			
942.2	175	154			
939.0	206	162			
933.9	239	180			



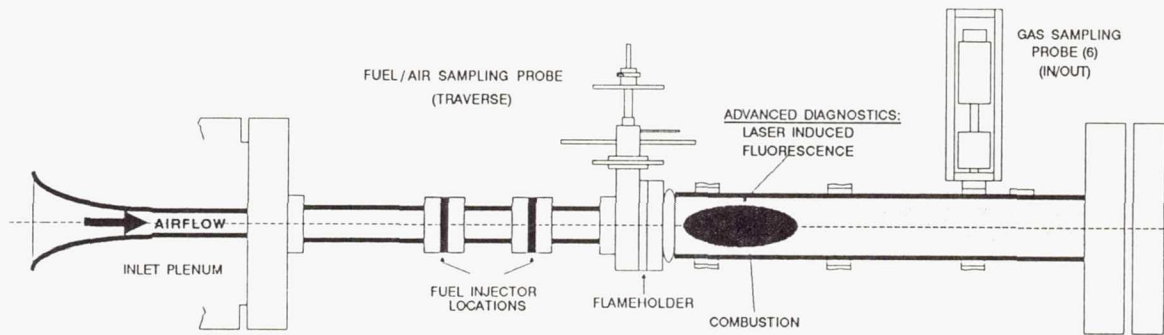

Figure 1.—High pressure and temperature squarewave flame tube.

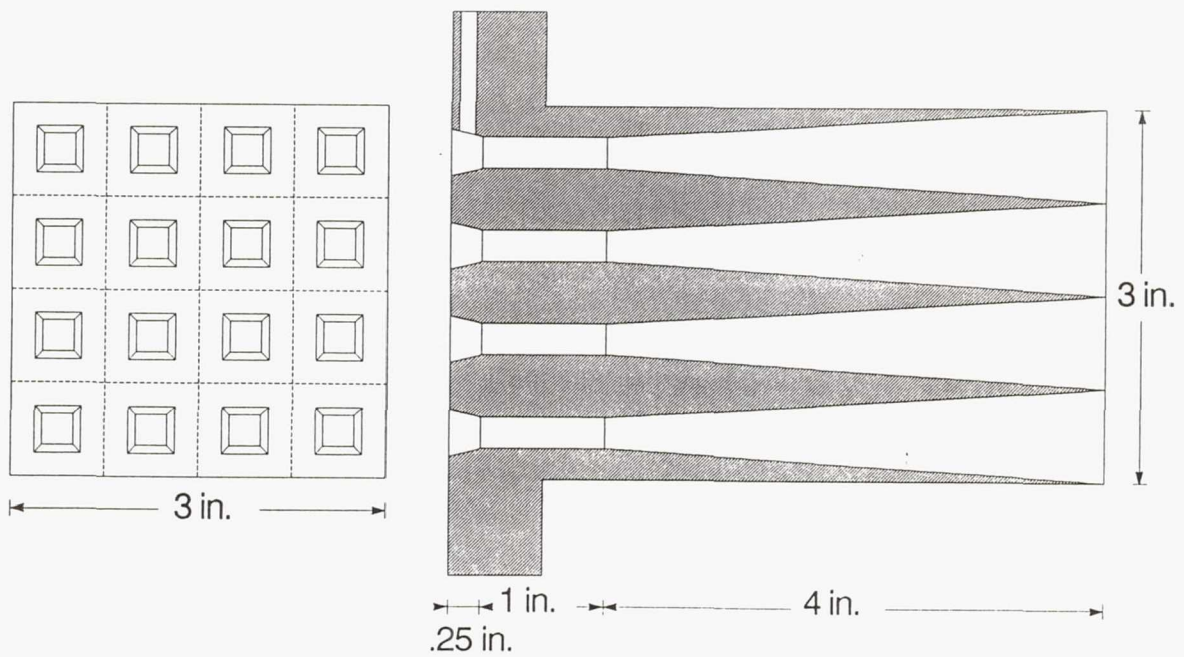

Figure 2.—Multiple tube fuel injector.

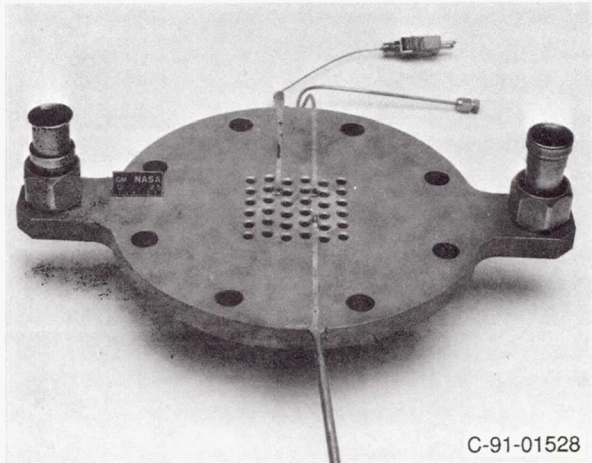

Figure 3.—Water cooled flame holder.

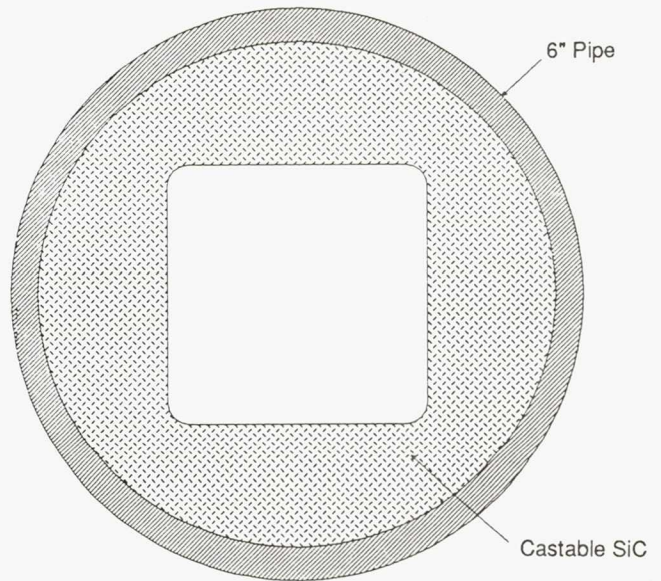

Figure 4.—Combustor cross section.

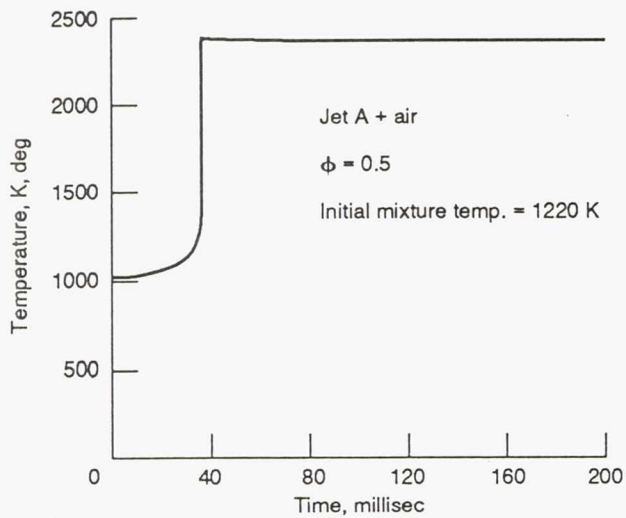

Figure 5.—Ignition delay time for Jet A + air.

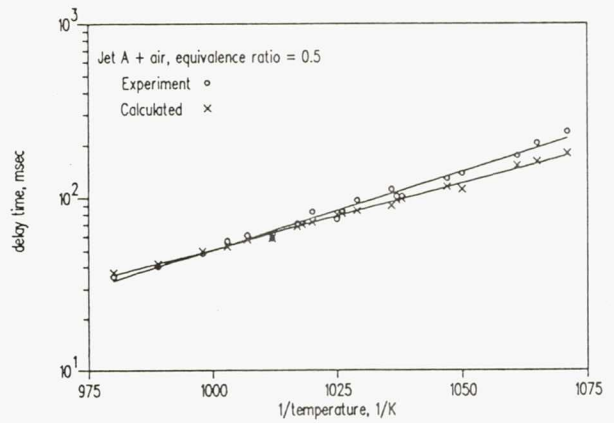

Figure 6.—Spontaneous ignition delay times for Jet A - air.

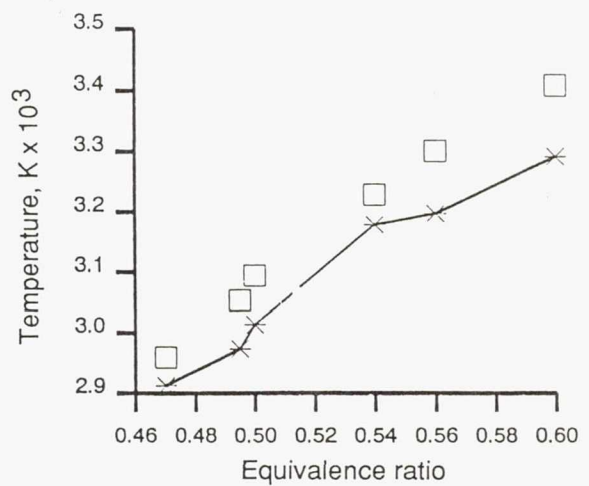
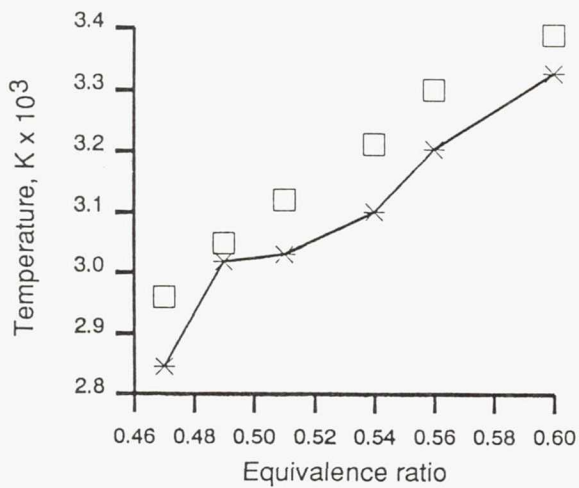
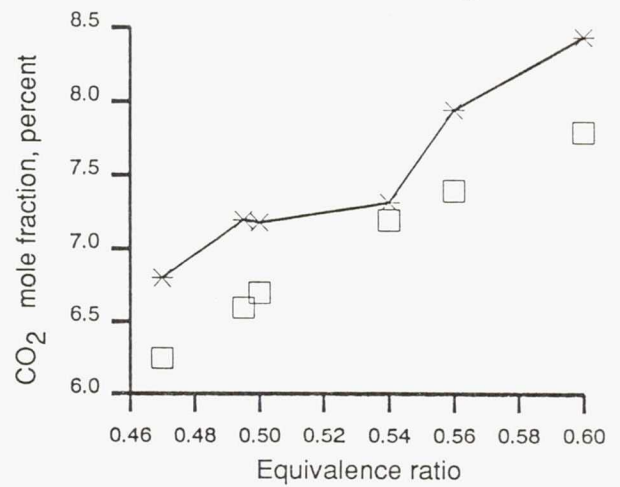
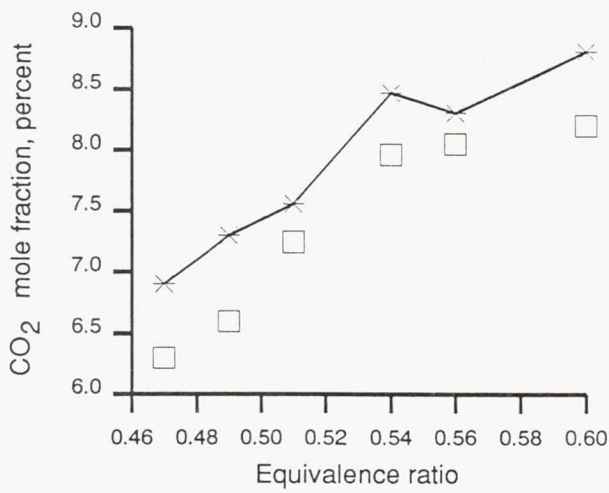
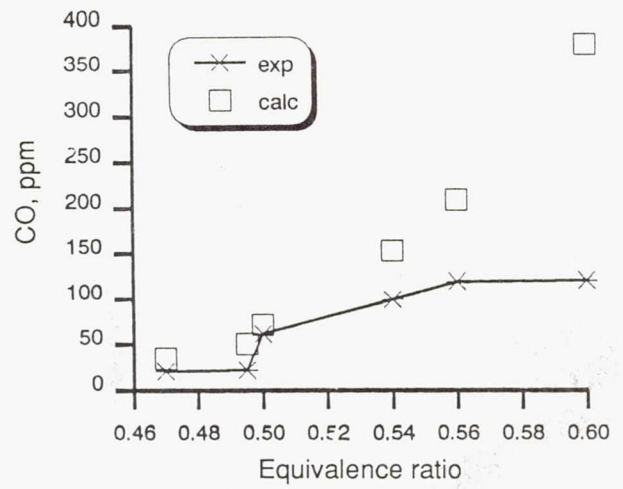
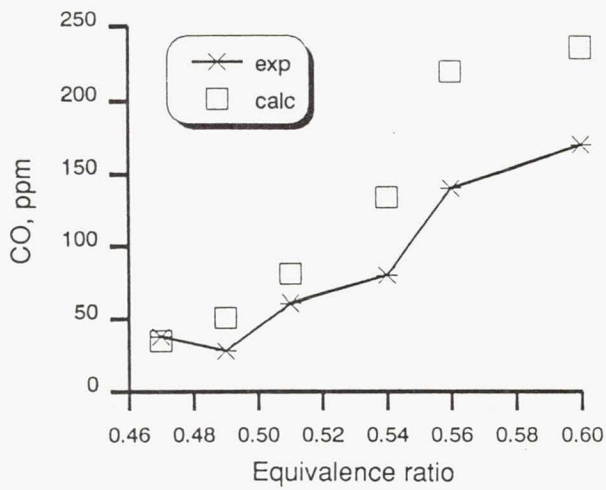

Figure 7.—Experimental and calculated specie concentrations and temperatures for Jet A oxidation at the probe #3 location.

Figure 8.—Experimental and calculated specie concentrations and temperatures for Jet A oxidation at the probe #2 location.

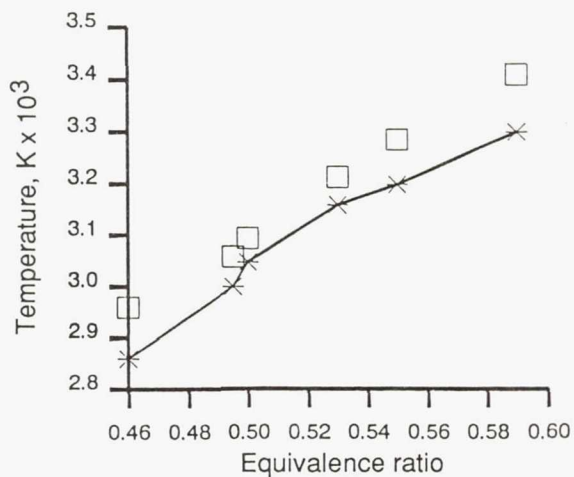
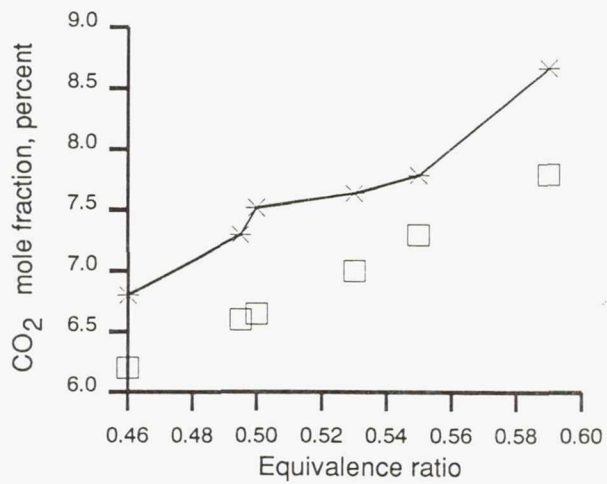
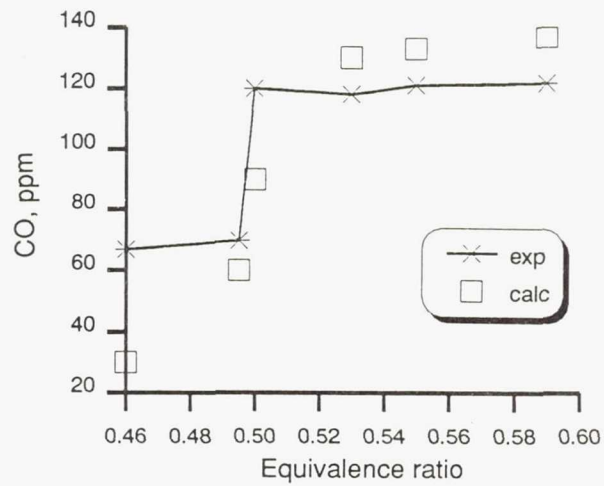

Figure 9.—Experimental and calculated specie concentrations and temperatures for Jet A oxidation at the probe #1 location.

# REPORT DOCUMENTATION PAGE

Form Approved  
OMB No. 0704-0188

Public reporting burden for this collection of information is estimated to average 1 hour per response, including the time for reviewing instructions, searching existing data sources, gathering and maintaining the data needed, and completing and reviewing the collection of information. Send comments regarding this burden estimate or any other aspect of this collection of information, including suggestions for reducing this burden, to Washington Headquarters Services, Directorate for Information Operations and Reports, 1215 Jefferson Davis Highway, Suite 1204, Arlington, VA 22202-4302, and to the Office of Management and Budget, Paperwork Reduction Project (0704-0188), Washington, DC 20503.

<b>1. AGENCY USE ONLY</b> (Leave blank)	<b>2. REPORT DATE</b>	<b>3. REPORT TYPE AND DATES COVERED</b> Technical Memorandum	
<b>4. TITLE AND SUBTITLE</b> Jet-A Reaction Mechanism Study for Combustion Application		<b>5. FUNDING NUMBERS</b>  WU-537-01-11 PE-1L162211A47A	
<b>6. AUTHOR(S)</b> Chi-Ming Lee, Krishna Kundu, and Waldo Acosta			
<b>7. PERFORMING ORGANIZATION NAME(S) AND ADDRESS(ES)</b> NASA Lewis Research Center Cleveland, Ohio 44135-3191 and Propulsion Directorate U.S. Army Aviation Systems Command Cleveland, Ohio 44135-3191		<b>8. PERFORMING ORGANIZATION REPORT NUMBER</b>  E-6279	
<b>9. SPONSORING/MONITORING AGENCY NAMES(S) AND ADDRESS(ES)</b> National Aeronautics and Space Administration Washington, D.C. 20546-0001 and U.S. Army Aviation Systems Command St. Louis, Mo. 63120-1798		<b>10. SPONSORING/MONITORING AGENCY REPORT NUMBER</b>  NASA TM-104441 AVSCOM TR-91-C-029	
<b>11. SUPPLEMENTARY NOTES</b> Prepared for the 27th Joint Propulsion Conference cosponsored by the AIAA, SAE, ASME, and ASEE, Sacramento, California, June 24-27, 1991. Chi-Ming Lee and Krishna Kundu, NASA Lewis Research Center. Waldo Acosta, Propulsion Directorate, U.S. Army Aviation Systems Command. Responsible person, Chi-Ming Lee, (216) 433-3413.			
<b>12a. DISTRIBUTION/AVAILABILITY STATEMENT</b>  Unclassified - Unlimited Subject Category 07		<b>12b. DISTRIBUTION CODE</b>	
<b>13. ABSTRACT</b> (Maximum 200 words) Simplified chemical kinetic reaction mechanisms for the combustion of Jet A fuel are studied. Initially 40 reacting species and 118 elementary chemical reactions are chosen based on the literature review of previous works. Through a sensitivity analysis with the use of LSENS General Kinetics and Sensitivity Analysis Code, 16 species and 21 elementary chemical reactions are determined for this study. This mechanism is first justified by comparison of calculated ignition delay time with available shock tube data, then is validated by comparison of calculated emissions from plug flow reactor code with in-house flame tube data.			
<b>14. SUBJECT TERMS</b> Jet engine fuels; Reaction kinetics; Combustion; Jet engine		<b>15. NUMBER OF PAGES</b> 12	
		<b>16. PRICE CODE</b> A03	
<b>17. SECURITY CLASSIFICATION OF REPORT</b> Unclassified	<b>18. SECURITY CLASSIFICATION OF THIS PAGE</b> Unclassified	<b>19. SECURITY CLASSIFICATION OF ABSTRACT</b> Unclassified	<b>20. LIMITATION OF ABSTRACT</b>

National Aeronautics and  
Space Administration

**Lewis Research Center**  
Cleveland, Ohio 44135

Official Business  
Penalty for Private Use \$300

**FOURTH CLASS MAIL**

ADDRESS CORRECTION REQUESTED



Postage and Fees Paid  
National Aeronautics and  
Space Administration  
NASA 451

**NASA**

---