

N91-32640

**DAMAGE TO METALLIC SAMPLES
PRODUCED BY MEASURED LIGHTNING CURRENTS**

Richard J. Fisher and George H. Schnetzer
Sandia National Laboratories
Albuquerque, NM 87185

ABSTRACT

A total of 10 sample disks of 2024-T3 aluminum and 4130 ferrous steel were exposed to rocket-triggered lightning currents at the Kennedy Space Center test site in Florida during the summer of 1990. The experimental configuration was arranged so that the samples were not exposed to the preliminary streamer, wire-burn, or following currents that are associated with an upward-initiated rocket-triggered flash but which are atypical of naturally initiated lightning. Return-stroke currents and continuing currents actually attaching to the sample were measured, augmented by close-up video recordings of approximately 3 feet of the channel above the sample and by 16-mm movies with 5-ms resolution. From these data it was possible to correlate individual damage spots with streamer, return-stroke, and continuing currents that produced them. Substantial penetration of 80-mil aluminum was produced by a continuing current of submedian amplitude and duration, and full penetration of a 35-mil steel sample occurred under an eightieth percentile continuing current. The primary purpose of the data acquired in these experiments is for use in improving and quantifying the fidelity of laboratory simulations of lightning burnthrough.

INTRODUCTION

Laboratory simulation of lightning arc effects has long been used in both engineering development studies and qualification testing. Such testing is widely employed throughout the aerospace industry, usually according to the SAE Committee AE4L lightning test specifications [1], MIL-STD-1757A [2], or some derivative thereof. In these documents, the components of the test currents to be applied are specified in considerable detail, and their physical correlation with corresponding components of natural lightning flash currents is established. However, when it comes to the details of test electrode geometry, spacing, and materials, these specifications are decidedly more vague and indicate no apparent basis for quantitative correspondence with actual lightning.

It is well known that erosion and penetration of metallic test materials during laboratory simulations is sensitive not only to the applied test current but equally so to the specifics of electrode geometry and materials.

References 1 and 2, for example, include cautionary notes and qualitative guidance for mitigating against these sensitivities. In a series of preliminary burnthrough experiments performed during 1988 using the Sandia Lightning Simulator (SLS)¹, the sensitivity of test results to test configurational parameters was observed to be pronounced. That is, for the same applied simulated return-stroke/continuing-current composites, the damage that resulted on identical aluminum and steel test specimens varied significantly as functions of the electrode configuration and arc length. These results and a subsequent cursory look into the literature served to stimulate a more in-depth consideration of the general issues of what should constitute the "proper" simulation technique for penetration testing and how to quantify the fidelity of that technique *vis-a-vis* results produced by natural lightning.

An extensive literature review was undertaken to determine the present general understanding of arc-to-metal interactions, particularly as relevant to the transfer of energy to an electrode surface [4]. Specific

¹ The SLS is described in detail in Reference 3.

attention was focused on arc physics, especially as related to atmospheric, high current, long duration arcs; lightning channel and attachment physics and phenomenology; lightning simulation technology; and welding technology. The survey succeeded in providing the desired overview; but the wherewithal, either theoretical or empirical, with which to reliably quantify simulation fidelity was not forthcoming.

One pragmatic and rather straightforward approach was suggested by an experiment conducted by Uman [5] in 1964. During the course of a summer, he exposed a set of copper disks to lightning by mounting them atop a TV tower. The resulting damage spots provided a qualitative indication of the diameter of the lightning attachment spot, but, unfortunately, there were no means available for measuring the incident current that produced the damage. It followed that acquisition of similar data points correlated to the incident current that caused them would provide a reliable data base against which to calibrate the laboratory simulation. Successful replication of the spots in the laboratory would then constitute a definitive validation of the test technique. Electrode parameters and other aspects of the test configuration could be systematically varied until the best duplication was achieved. Under each variation, the applied current, particularly the continuing current, which is primarily responsible for producing burnthrough, would be tailored to correspond to the measured natural lightning that caused the individual spot in question.

During the summer of 1990, such an experiment was performed at the Kennedy Space Center (KSC) rocket-triggered lightning test site in Florida. Disk samples of nominal 80-mil-thick 2024-T3 aluminum and 35-mil-thick 4130 ferrous steel were exposed to fully recorded return-stroke and continuing currents. The remainder of this paper describes the experiment and the data that were acquired.

INCIDENT LIGHTNING CURRENT

For these experiments, the rocket and wire dispensing assemblies developed by the Centre D'Etudes Nucleaires de Grenoble (CENG) in France were employed [6]. There are several variations of these systems. The one employed here, called LRSG (for lightning rocket system, grounded), incorporates a 2100-ft length of wire that is tied to earth ground at the bottom of its launch tube. The typical flash current that results from this system is illustrated schematically in Figure 1.

There are certain features of this current that depart from those of a naturally initiated flash, most notably the presence of the few hundred milliseconds of low-level initial continuous current (ICC) that precedes the first return stroke. A second, more subtle difference is that the first return stroke of the triggered flash is thought to be most often initiated by a dart, rather than stepped, leader and is otherwise typical of a subsequent return stroke of a purely natural flash [7]. From the viewpoint of the objectives of the present experiment, however, this latter issue is of no practical consequence. This is so because, in a metal of any appreciable thickness, virtually all penetration is due to the intermediate and continuing-current components of the flash current, which in triggered flashes fall well within the statistical envelopes of their counterparts in purely natural flashes.²

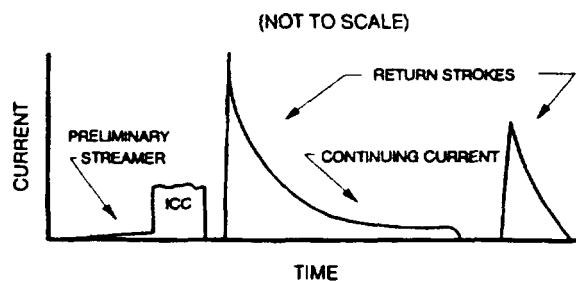

Figure 1. Typical Rocket-Triggered Lightning (RTL) Flash Current

² It is postulated that, in some instances, the shock wave associated with subsequent strokes following significant continuing currents may contribute to material erosion by splashing away molten material. However, since there are no significant differences between subsequent strokes of triggered and naturally initiated lightning, this effect should be faithfully represented in the present results.

The ICC flows in the channel prepared by the vaporized wire that terminates on the launcher tube. The tube is grounded to earth potential via an array of stranded steel wire cables. As indicated in Figure 2, it was arranged that this portion of the current would not be intercepted by the test specimens so that interpretational complications associated with this component of the triggered lightning flash were avoided. The typical sequence following cessation of the ICC was that one or more return strokes, often with intervening continuing currents, would jump from the ICC channel and attach to the top of the sample, evidently because this path to ground presented a lower impedance than the decayed original channel. In this way the desired data spots created by individual return strokes and return-stroke/continuing-current combinations were acquired.

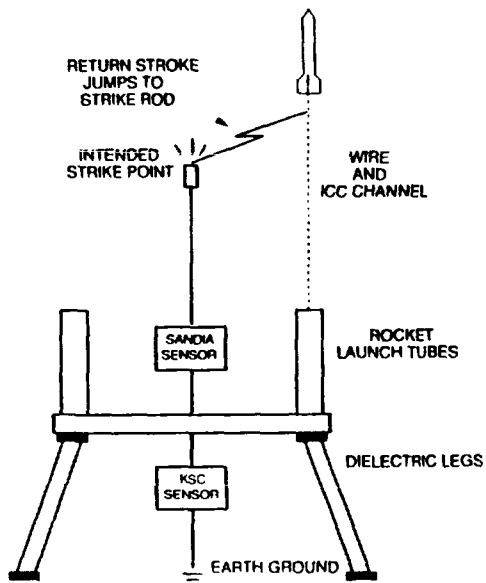

Figure 2. RTL Materials Damage Experiment Configuration

EXPERIMENT DESCRIPTION

Figure 3 shows the fixture in which the individual samples were held. The development of upward streamers from the edge of the brass fixture cup, which would lead to undesired attachments there, were suppressed by the presence of the dielectric sleeve of woven phenolic material. Two 0.5-in holes were provided in the dielectric shield to prevent the build-up of rain water

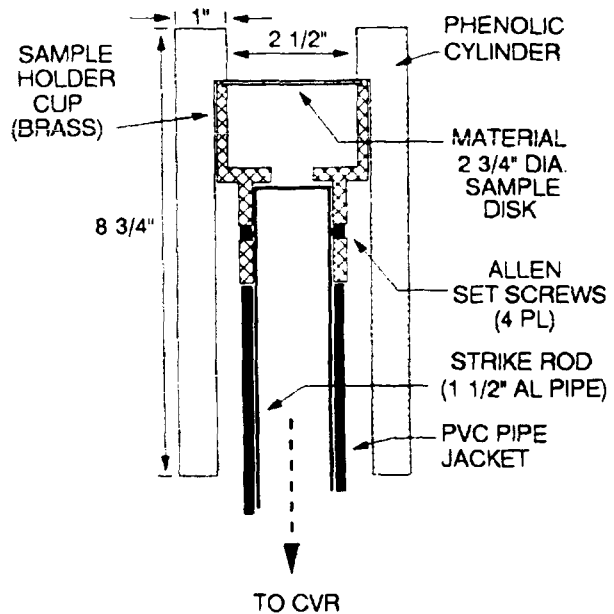

Figure 3. RTL Materials Damage Specimen Fixture

over the surface of the sample. The entire arrangement was mounted on a 10-ft hollow aluminum pole, the bottom of which was tied by a 1.5-in braided ground strap to the input of a coaxial 0.5-mΩ current viewing resistor (CVR). In order to discourage the attachment of return strokes along its length, the pole was encased in PVC pipe of ~0.2-in wall thickness from just below the fixture cup to the bottom of the pole.

The potential data return during any triggering session was increased by arranging four identical poles and fixtures on a hinging mechanism so that they could be remotely raised and lowered sequentially during the course of a given storm. Figure 4 shows the hinging mechanism that was employed. A network of plastic ropes and metal pulleys led back to the instrumentation van to allow the raising and lowering of the samples. For safety reasons, two of the sets of pulleys over which the ropes passed were tied together and led to local grounds via braided strap. The eyebolts through which the ropes passed just outside the door of the instrumentation van were also electrically tied together and to the structure of the steel van so that the ends of the ropes were held at the same potential as the structure. The ropes were only operated between rocket launches, and only then after clearance from the rocket launch controller was received.

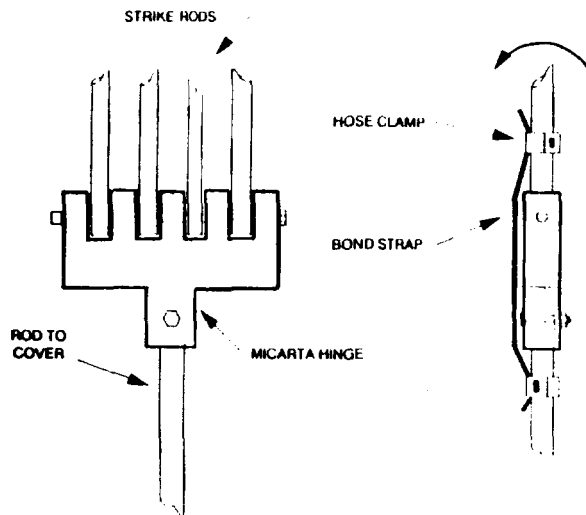

Figure 4. Hinging Mechanism for Raising and Lowering Test Specimens

INSTRUMENTATION

Measurement of the incident channel current was performed with the instrumentation provided by the Sandia Transportable Triggered Lightning Instrumentation Facility (SATTLIF), which is described in detail in a companion paper in these proceedings [8]. The voltage developed by the coaxial CVR described above was fed to two different fiber optic data links (FOLs) and transmitted to the SATTLIF for recording. In order to capture the return-stroke currents, one channel consisted of a NanoFast 300-2A FOL, followed by a 6-MHz filter and LeCroy 9400A digitizing oscilloscope. Overall bandwidth of the system was set by the 164-ns rise time of the CVR. The digitizer was operated in the segmented memory mode at an 80-ns sampling rate. This permitted the capture of the first 200 μ s of up to eight individual return strokes per flash. A trigger threshold of 1000 A was chosen. The NanoFast FOL transmitter is provided with an internal calibration signal generator, and a cal record was recorded prior to each test event as part of the countdown checklist. The return-stroke signals were also backed-up on a 1-MHz direct-record magnetic tape recorder channel. Return-stroke measurements obtained with this instrumentation compared well with those made by KSC personnel with their own system, the sensor of which was in series with the Sandia CVR (Figure 2). A comparison of the common data is given in Reference 8.

More important to the objectives of these experiments was the measurement of the low-level, long-duration continuing currents. These were recorded via a second channel that consisted of a 1-MHz Dymec frequency modulated (FM) FOL playing into both a 500-kHz FM Ampex PR2300 magnetic tape recorder and two LeCroy 9400A digitizer channels. The sensitivities of the two digitizer channels were staggered, and a 2-A continuing-current resolution was achieved. The digitizer was operated in the single segment mode with a 40- μ s sampling rate. The Dymec channel provided a dc to 500-kHz bandwidth and was found to perform extremely reliably throughout the course of the fielding period. A pneumatically actuated pulse calibration signal was provided at the input of the Dymec transmitter so that an end-to-end calibration signal could be recorded prior to each test event. The associated LeCroy channel was triggered at a level corresponding to 1000 A.

Two photographic systems were also employed. One was a Super VHS black and white video system that was zoomed to capture a 3-foot distance above and below the erected sample. The main function of this recording was to aid, immediately following the event, in determining whether or not the erected sample had been struck, so that a decision could be made as to whether or not to exchange it for a fresh one. The lens was operated at its minimum aperture (f/22), and neutral density filters were added to provide up to an equivalent of eight additional f-stops. These records are thought to represent the closest known photographs of lightning attachment points, and they reveal some interesting streamer behavior that is presently being analyzed in detail.

The time resolution of the video records is limited by the VCR framing rate to ~30 ms. In order to provide a resolution sufficient to separate individual return strokes within a flash, a 16-mm film cinematic framing camera was also operated. The field of view was adjusted to cover the entire experiment tower, and a framing rate of 200 fps was chosen, providing a 5-ms resolution. The records obtained with this camera were of critical importance in sorting out where each stroke terminated. Analysis on a frame-by-frame basis and comparison with the various current records ultimately enabled the correlation of individual damage

spots on the samples with the specific return strokes and continuous currents that caused them.

DATA AND DISCUSSION

Data spots on a total of six aluminum and four steel samples were obtained during three separate storms occurring on August 8, 9, and 11. Several of the more interesting examples are presented below. A fuller presentation and discussion of the data are available in Reference 9.

Figure 5 shows a photograph of the aluminum sample exposed to Flash 90-02 and a plot of the corresponding flash current recorded by the 500-kHz Dymec channel. These data illustrate the importance of the cinematic films. The sample exhibits numerous small surface marks clustered near the center. These correspond to upward-going streamers, which were recorded during several events by the close-up video system. Aside from those, there is a single significant spot, identified as RS#8 in Figure 5a. In this case, the cinematic film clearly revealed that the wind carried the ICC channel across the fronts of three samples that were lying horizontal prior to being raised for exposure. As a result, the first seven strokes attached to one of the horizontal samples, while only the last stroke attached to the erected one, thereby creating the data spot shown in the figure.

The stroke that hit this sample had a peak current of 13 kA. A charge of 7.6 C was transferred by the continuing current, which lasted approximately 50 ms. The spot is a raised mound of crystalline material of 0.16-in diameter and 0.002-in height above the flat surface. There is a pinhole in the center of the mound with a depth of approximately 0.002 in below the flat surface. Such an isolated spot, caused by an unambiguously known current, represents precisely the sort of data that was sought.

The two most dramatic results are indicated in Figures 6 and 7. Flash 90-03 consisted of two strokes, both of which were confirmed photographically to have hit the top of the sample. The first stroke ($I_p=13$ kA) was followed by a continuing current that transferred ~13.6 C of charge at a sustained level of 100 A. The corresponding spot is evidently the large one (#1 in

Figure 6a), which has a diameter of 0.3 in. Inside the spot is a 0.19-in-diameter raised mound of crystalline material of ~0.04-in height. This bead is surrounded by a crater of maximum depth of 0.001 in. There is no significant discoloration on the back side of the spot, but there is a 0.06-in-diameter round dot, very much like a single braille dot. Precise correlation of the other two major spots (#2 and #3) appearing in the photograph is more tenuous due to the clear photographic evidence that only two return strokes attached to the erected sample. Nevertheless, tentative correlation has been established based on a detailed examination of all the data and a rationale that is discussed in Reference 9.

Figure 7 corresponds to a 0.035-in thick steel sample. The three distinct overlapping spots have diameters of 0.33, 0.39, and 0.28 in, respectively, and the sample was fully penetrated at the center spot. Again, as confirmed by the film record, the first two strokes indicated in Figure 7b terminated on one of the horizontal samples. Only the current to the right of the indicated line attached to the top of the sample. The current consisted of a single return stroke and a rather severe continuing current. The large peak occurring at ~540 ms represents a large surge (peak of ~1500 A) riding on the established continuing current. Figure 8 shows the back side of the sample. The appearance of the melted material is different from that of the aluminum. It is not crystalline, and seems to have flowed smoothly. In several instances, the residue is silver and shiny, indicating some sort of chemical separation process of the alloy constituents.

Aside from their immediate utility in the process of quantifying simulation fidelity, the data offer additional points of interest. Consider Figure 7. The continuing current following the initial return stroke in Flash 90-03 had a duration of ~120 ms, a sustained current level of ~100 A, and a total charge transfer of 13.6 C. According, for example, to Cianos and Pierce [10], this amplitude and duration fall at approximately the thirtieth percentile points on their respective frequency distributions. The 13-C charge transfer falls at the twelfth percentile. That is, only the stated percentage of all continuing currents have smaller corresponding values. Thus, by any measure,

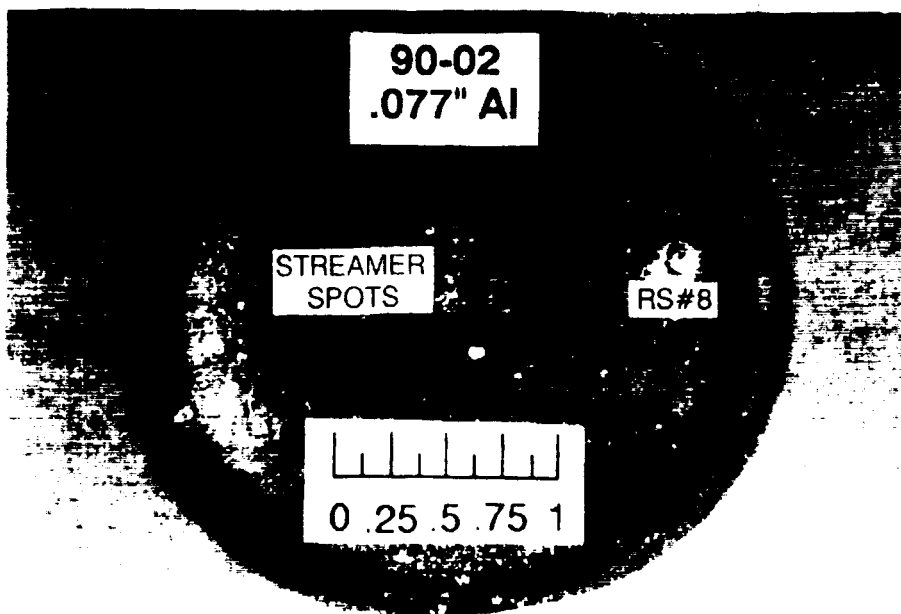

(a)

FULL FLASH 90-02
(0-500 kHz FM RECORD)

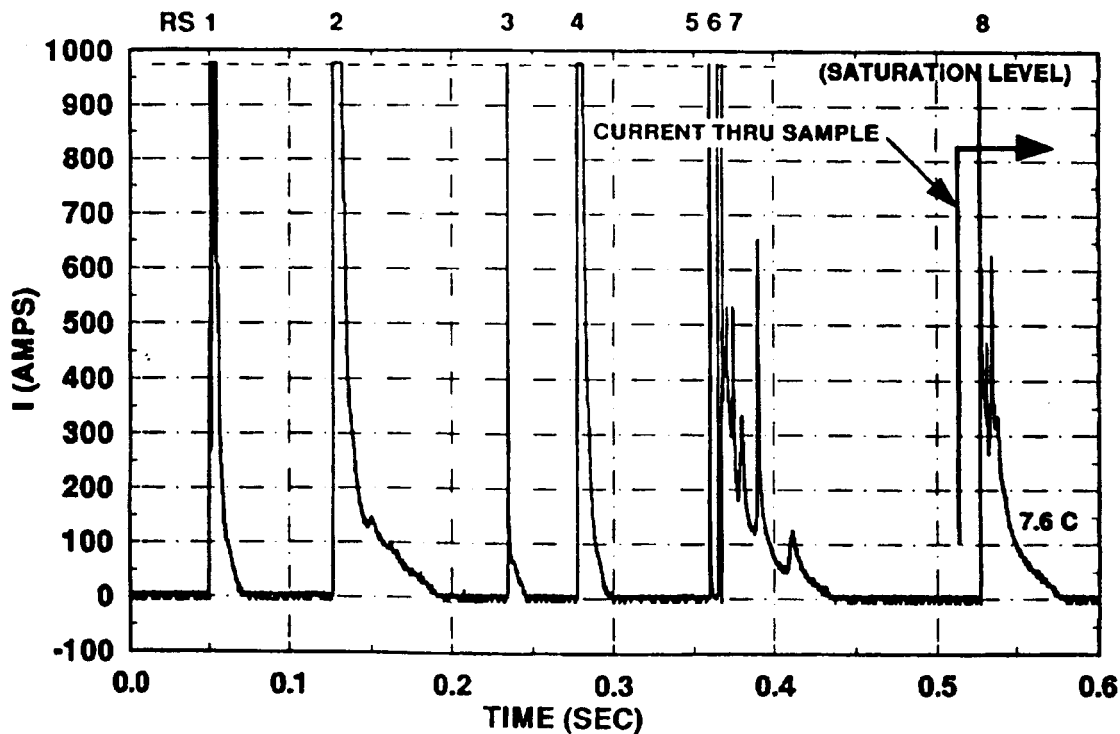

(b)

Figure 5. a) 80-mil-Thick Al Specimen Exposed on Flash 90-02 and
b) Current Recorded on Same Flash

BLACK AND WHITE PHOTOGRAPH

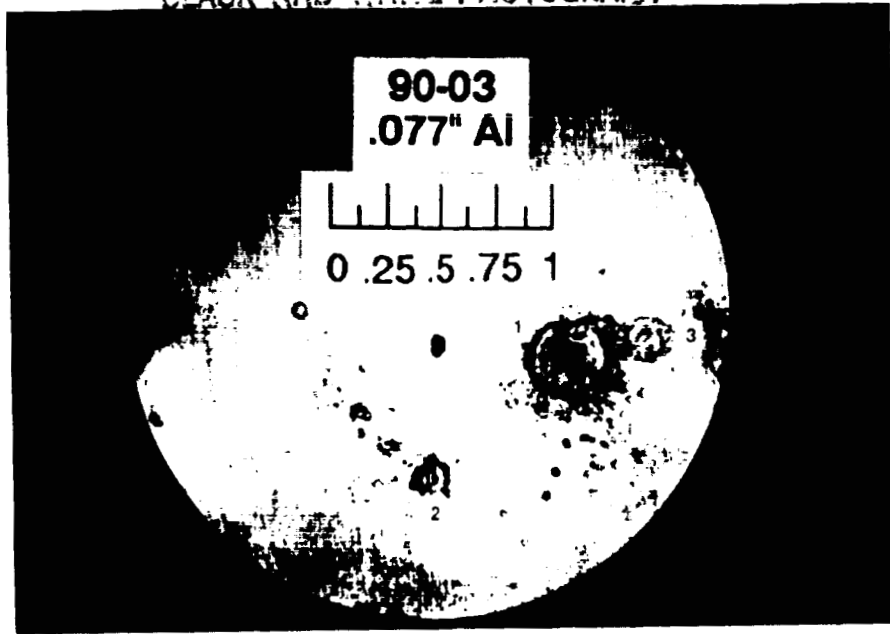

(a)

FULL FLASH 90-03
(0-500 kHz FM RECORD)

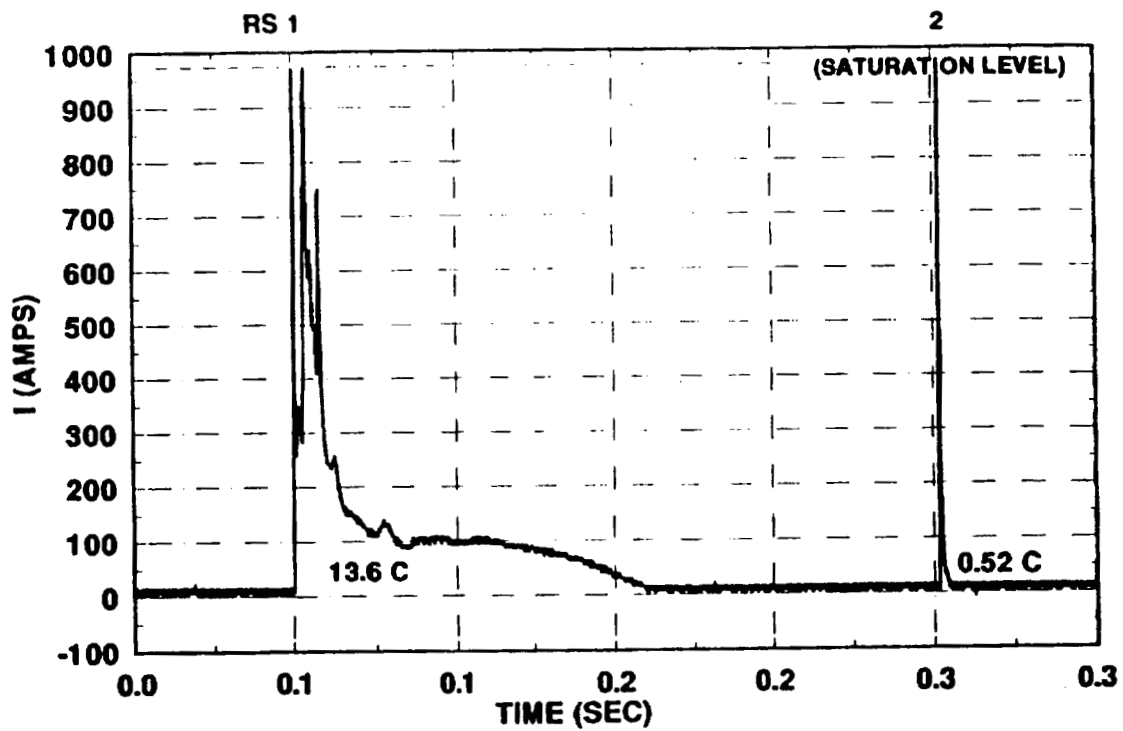

(b)

Figure 6. a) 80-mil-Thick Al Specimen Exposed of Flash 90-03 and
b) Current Recorded on Same Flash

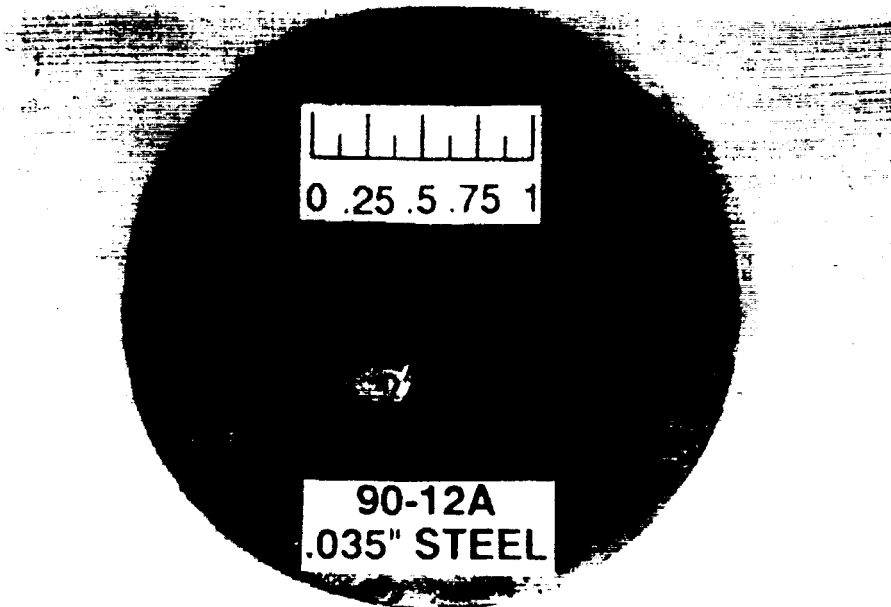

(a)

FULL FLASH 90-12
(0-500 kHz FM RECORD)

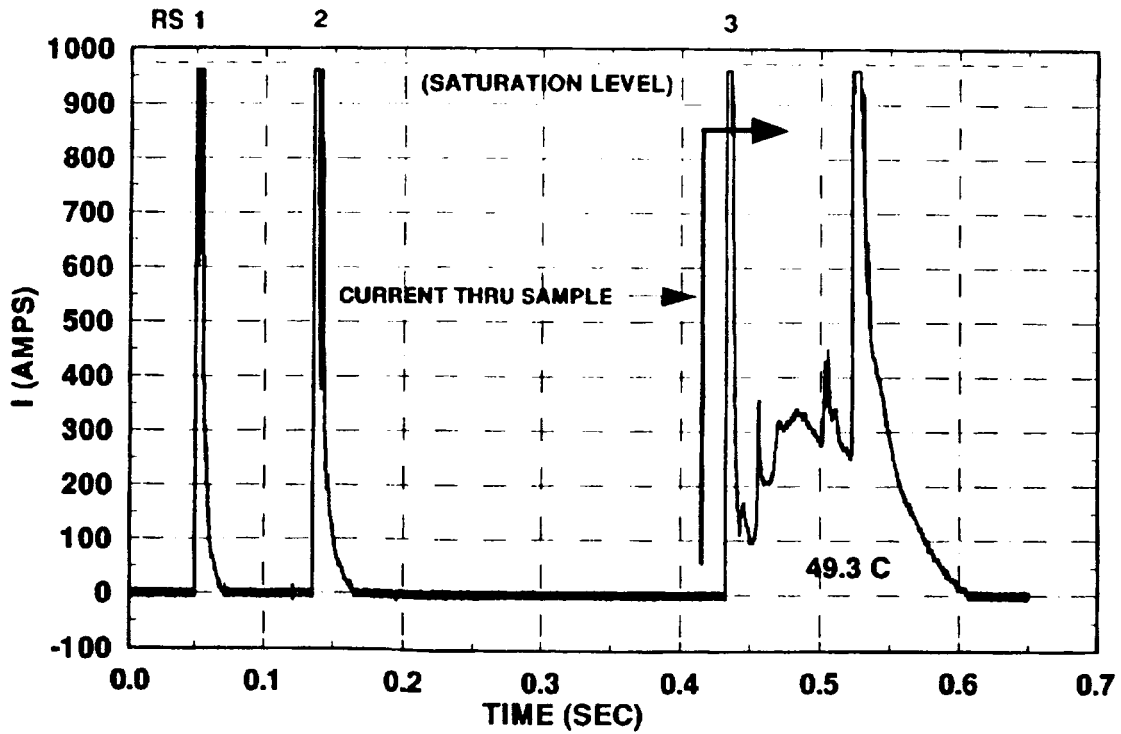

(b)

Figure 7. a) 35-mil-Thick Steel Specimen Exposed on Flash 90-12 and
b) Current Recorded on Same Flash

GRAND JURY
BLACK AND WHITE PHOTOGRAPH

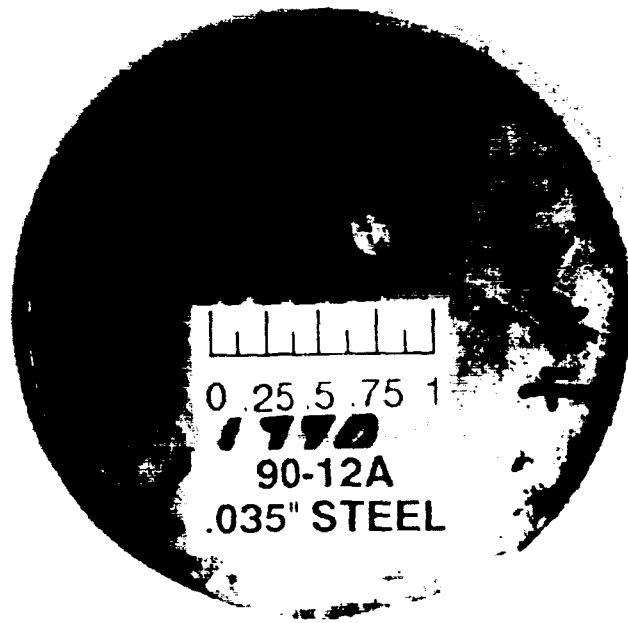

Figure 8. Back Side of 35-mil-Thick Specimen Exposed on Flash 90-12

90-03 represents a flash of very modest severity. It nevertheless produced significant damage on a material and thickness with wide practical aerospace applications, many with safety implications under nonflight conditions.

The 49-C charge transfer represented by the final stroke and continuing current indicated in Figure 7b corresponds to approximately the eightieth percentile level, according to the Cianos and Pierce model. It therefore ranks as a relatively severe, but by no means extreme, flash.

No destructive metrology on the samples is planned, at least until after the laboratory duplication efforts are completed.

CONCLUSIONS

Nine individual damage spots were acquired for which correlation with specific and measured return strokes or return-stroke/continuing-current combinations have been established with reasonable to excellent confidence. These data represent a reliable

set of benchmarks against which the fidelity of laboratory simulation of lightning penetration can be improved and quantified, at least for aluminum and steel. This will be done by exposing identical samples in the SLS to the same currents as those that produced the benchmark spots. Simulator electrode and other test configurational parameters will be varied until the best replications are obtained. *Post-mortem* analysis of all the samples will then be used to quantify the achieved duplication in terms of erosion diameter and depth and relevant metallurgical factors. Additional benchmark data spots would be very valuable, both to augment the statistical base on the present materials and to widen coverage to other materials.

One particularly significant outcome of the present experiment is definitive confirmation of the possibility of burnthrough of aluminum of thickness in excess of 80 mil, under nonflight conditions, by continuing currents of median intensity or less.

ACKNOWLEDGEMENTS

The authors wish to express their appreciation to the Kennedy Space Center and Mr. William Jafferis for the opportunity to participate in their 1990 rocket-triggered lightning program. Particular thanks are due to Mr. Jafferis for his enthusiastic personal support of these experiments and to Messrs. Andre Eybert-Berard and Louis Barret of CENG for their cooperation in conducting the rocket operations. This work was jointly sponsored by the Department of Energy, by the Project Manager's Office of the Department of the Army, and by the U.S. Army Armament Research, Development, and Engineering Center (ARDEC).

REFERENCES

1. *Lightning Test Waveforms and Techniques for Aerospace Vehicles and Hardware*, Report of SAE Committee AE4L, June 20, 1978.
2. "Lightning Qualification Test Techniques for Aerospace Vehicles and Hardware," *MIL-STD-175A*, 20 July 1983.
3. White, R. A., "Full-System Tests Using the Sandia Lightning Simulator," *Proc. 1983 Int. Conf. on Lightning and Static Electricity*, April 1983.
4. Fisher, R. J., and M. A. Uman, *Simulation Fidelity in Lightning Penetration Studies*, SAND89-3051, February 1990.
5. Uman, M. A., *All About Lightning*, Dover (1986), pp 88-89.
6. Larouche, P., A. Eybert-Berard, and L. Barret, "Triggered Lightning Flash Characterization," *Proc. 1985 Int. Conference on Lightning and Static Electricity*, June 1985.
7. Uman, M. A., "Natural and Artificially-Initiated Lightning and Lightning Test Standards," *Proc. IEEE*, Vol. 76, No. 12, December 1988.
8. Schnetzer, G. H. and R. J. Fisher, "The Sandia Transportable Triggered Lightning Instrumentation Facility (SATTLIF)," *Proc. 1991 Int. Conf. on Lightning and Static Electricity*, April 1991.
9. Fisher, R. J., and G. H. Schnetzer, *1990 Sandia Rocket-Triggered Lightning Tests at Kennedy Space Center, Florida*, SAND90-2926, February 1991.
10. Cianos, N., and E. T. Pierce, *A Ground-Lightning Environment for Engineering Use*, SRI Report, Project 1843, August 1972.