

N91-32699

**ELECTROMAGNETIC TOPOLOGY: CHARACTERIZATION OF INTERNAL
ELECTROMAGNETIC COUPLING**

J.P. Parmantier*, J.P. Aparicio** and F. Faure**

*Dassault Aviation, B.P. 300, 92214 SAINT-CLOUD, FRANCE

**Office National d'Etudes et de Recherches Aérospatiales
B.P. 72, 92322 CHATILLON CEDEX, FRANCE**ABSTRACT**

This paper presents the main principles of a method dealing with the resolution of electromagnetic internal problems: Electromagnetic Topology. A very interesting way is to generalize the multiconductor transmission line network theory to the basic equation of the Electromagnetic Topology: the B.L.T. equation.

This generalization is illustrated by the treatment of an aperture as a four port junction. Analytical and experimental derivations of the scattering parameters are presented. These concepts are used to study the electromagnetic coupling in a scale model of an aircraft, and can be seen as a convenient means to test internal electromagnetic interference.

1. INTRODUCTION

The study of the internal electromagnetic problem should, in the future, lead to the development of an electromagnetic design tool. An electromagnetic design can be carried out in four phases. The first one is to design a first prototype. The second phase is to calculate the interference in the system previously defined. In a third phase the system has to be optimized, to be in agreement with specific goals such as price, but also weight. The last phase is to establish maintenance specifications once the system is entirely defined.

Electromagnetic Topology is a powerful frequency method developed several years ago specially for aeronautics by C.E. Baum [1] in the USA, and that could answer these four phases. Nowadays, studies are being made to see how far this theory can be applied or modified or completed to be successful.

2. OVERVIEW OF ELECTROMAGNETIC TOPOLOGY**FUNDAMENTAL APPROACH**

The main concept of Electromagnetic Topology, as defined by C.E. Baum, is to divide the space of interest into volumic zones in order to break down a total complex electromagnetic problem into a group of small problems independent of each other.

The topological diagram is a helpful abstract vision of the geometry of a system, taking into account the electromagnetic interactions between the different volumes. With this diagram, an inventory of all the penetration paths into the previous volumes can be made and then an interaction graph drawn: this description of the electromagnetic interaction between volumes is better suited than the diagram to computerization. Figure 1 represents a superimposition of a topological diagram with an associated interaction graph.

According to the theory, the calculation of the interference in the system is provided by deriving the topological network(s) associated to the interaction graph. Figure 2 is an example of such a network dealing with one external penetration path of the interaction graph presented in figure 1. A network is constituted by tubes related to each other through junctions. The signal propagating on the tubes is understood in terms of wave vectors $W(z)$ and the coupling of external sources in terms of source wave vectors W_s . One can then derive relations involving all the waves on the network, considering supervectors (vectors of vectors) and supermatrices (matrices of matrices). The propagation equation relates the wave supervectors at each extremity of the tubes $W(0)$ and $W(L)$ by means of a propagation supermatrix Γ :

$$W(L) = \Gamma W(0) + W_s \quad (1)$$

The propagation equation relates the outgoing wave supervectors $W(0)$ and the incoming wave supervectors $W(L)$ by means of a scattering supermatrix S :

$$W(0) = S W(L) \quad (2)$$

Combining (1) and (2), a single equation can then be derived, taking into account all the electromagnetic interactions on the network: it is called the B.L.T. equation (Baum - Liu - Tesche):

$$(1 - S\Gamma) W(0) = S W_s \quad (3)$$

One can already measure how this equation can be useful to perform the optimization phase of an electromagnetic design. However, the main problem is to express the waves and S and Γ supermatrices in any coupling configuration.

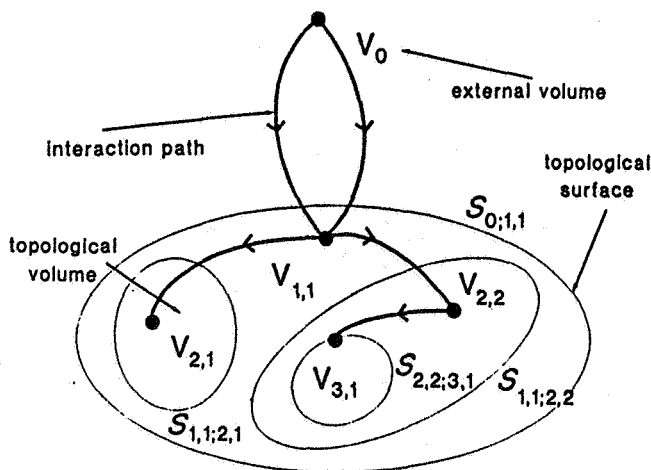

Figure 1: Topological diagram and associated topological graph.

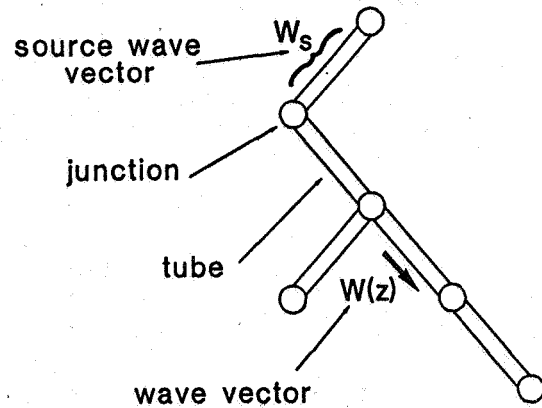

Figure 2: Topological network.

A QUALITATIVE APPROACH

In this approach, the concepts of topological diagram and graph remain valid. The difference is that all the evaluations of the interference are made by means of transfer functions. For this, judicious observables must be defined at each node of the graph, such as electromagnetic fields or currents and voltages and related by means of matricial expressions involving transfer operators $T_{i,j;k,l}$ as defined in figure 3. As an example, the current and voltage at node 3.1 $\begin{Bmatrix} I \\ V \end{Bmatrix}_{3.1}$ is given with respect to external electromagnetic

field $\begin{Bmatrix} E \\ H \end{Bmatrix}_0$ by the relation:

$$\begin{Bmatrix} I \\ V \end{Bmatrix}_{3.1} = T_{3.1;2,2} T_{2,2;1,1} \left(T_{1,1;0}^1 + T_{1,1;0}^2 \right) \begin{Bmatrix} E \\ H \end{Bmatrix}_0 \quad (4)$$

This tool is well suited to evaluate interference on a given structure and to propose maintenance specifications. The transfer operators can be measured or estimated (defining bounds with matricial norms for example) [1],[3]. The main problem is that this approach poorly lends itself to foresee the interference value when the geometry of the structure is modified.

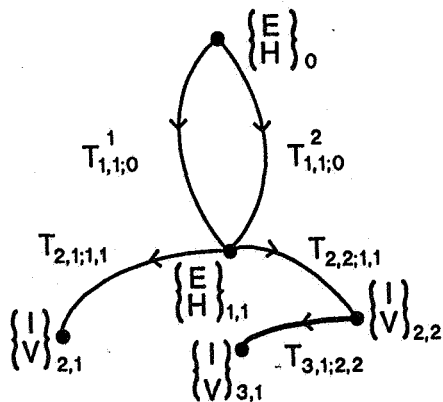

Figure 3: Transfer functions on a topological graph.

A NEW APPROACH COMBINING QUANTITATIVE AND QUALITATIVE ASPECTS

The two previous fundamental approaches must progress each in its own way, but it must always be kept in mind, that they must meet and merge in a single approach in the future.

Today, an approach conciliating the two is developed, based on the fact that a very important way to propagate the interference is constituted by cables. As a matter of fact, the multiconductor transmission line network theory is well suited to the B.L.T. equation formalism because all the quantities defined in (3) can be easily expressed with respect to current $I(z)$ and voltage $V(z)$ observables all along the lines [2],[5]. Figure 4 shows the electrical modeling of a multiconductor line cell where Z and Y are the distributed shunt impedance and parallel conductance matrices respectively. V_s and I_s are the shunt voltage and parallel current generators dealing with the coupling of external sources on the wires.

A Z_c matrix can be defined on each transmission line by:

$$Z_c = (Z.Y)^{\frac{1}{2}} \tag{3}$$

which allows to express the waves $W(z)$ as:

$$W(z) = V(z) + Z_c I(z) \tag{4}$$

Γ and W_s quantities can also be easily derived from Z and Y matrices and V_s and I_s vectors.

To obtain a generalization of this network transmission line formalism for the treatment of a global electromagnetic internal problem, one may think of integrating other forms of electromagnetic couplings into this theory. Effectively, apertures, joints, seams, antennas are very common and important penetration points in aeronautical vehicles.

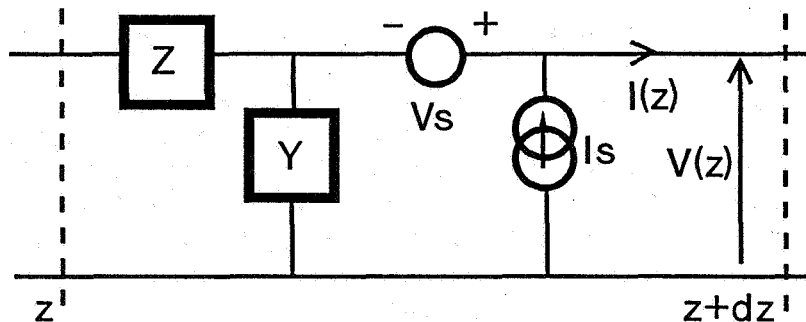

Figure 4: Electrical modeling of a multiconductor cell.

This can be done in two ways. The first one deals with distributing V_s and I_s generators all along the lines, using direct measurements or 3-dimensional codes. The second one consists in characterizing the coupling in terms of a network junction. This is what will be discussed now.

3. ELECTROMAGNETIC COUPLING THROUGH AN APERTURE DESCRIBED AS A JUNCTION

3.1. COUPLING OF TWO WIRES LOCATED ON BOTH SIDES OF AN APERTURE

Geometrical configuration

The configuration is represented in figure 5. The aperture is circular, with a diameter d , but the study remains valid for any shape. Both wires of length l are parallel to a ground plane at heights h_1 and h_2 respectively. The main hypothesis here is that conducting wire paths always prevail on any external radiation field.

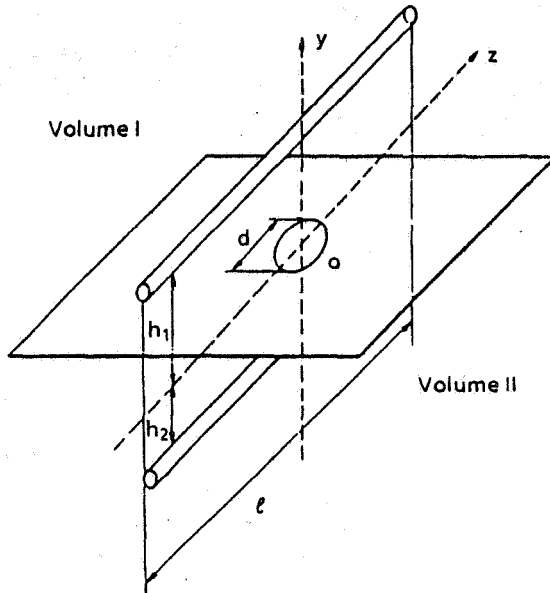

Figure 5: Coupling of two wires located on both sides of an aperture.

Electrical modeling and scattering parameters for small apertures

This model is valid insofar as the resonances of the aperture are not involved. The electrical scheme associated with this configuration is shown in figure 6 (the reaction of the inner wire is not taken into account). It can be shown that current I and voltage V in the upper volume, create in the lower wire shunt current I_{eq} and serial voltage V_{eq} generators [3], defined as:

$$V_{eq} = j\omega\alpha I \quad (5)$$

$$I_{eq} = j\omega\beta V \quad (6)$$

One can consider this configuration as a four port junction. The scattering parameters determination implies that each port is loaded on the characteristic impedance of the lines connected to Z_{cI} and Z_{cII} respectively (see figure 6).

A 4x4 matrix $[S]$ is then derived and can be divided into four blocks as follows [4]:

$$[S] = \begin{bmatrix} S_{I,I} & S_{I,II} \\ S_{II,I} & S_{II,II} \end{bmatrix} \quad (7)$$

Figure 6: Electrical modeling of the junction dealing with the coupling of two wires through an aperture.

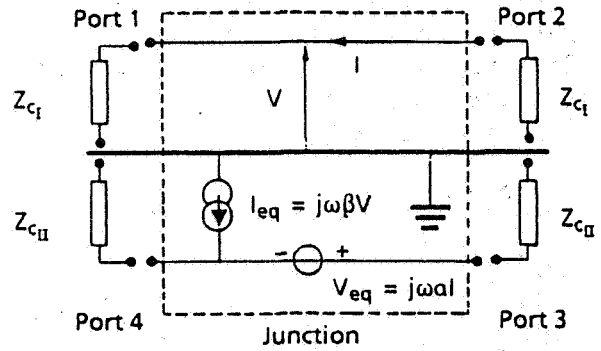

$S_{I,I}$ and $S_{II,II}$ are 2x2 matrices dealing with the scattering parameters of a transmission line and are only slightly affected by the presence of the aperture. More important are the 2x2 blocks $S_{I,II}$ and $S_{II,I}$ dealing with the signal transfer from one side of the structure to the other. The expression of $S_{II,I}$ components is given by:

$$S_{II,I} = \begin{bmatrix} \frac{j\omega}{2} \left(\beta Z_{cII} + \frac{\alpha}{Z_{cI}} \right) & \frac{j\omega}{2} \left(\beta Z_{cII} - \frac{\alpha}{Z_{cI}} \right) \\ \frac{j\omega}{2} \left(\beta Z_{cII} - \frac{\alpha}{Z_{cI}} \right) & \frac{j\omega}{2} \left(\beta Z_{cII} + \frac{\alpha}{Z_{cI}} \right) \end{bmatrix} \quad (8)$$

Scattering parameters for large apertures

It must be noted that the relation (8) still remains valid for low frequencies (before the resonances of the wires) and can inspire an efficient way to go back to α and β values.

However, when the frequency increases, the best way to characterize the aperture coupling is the measurement. The scattering parameter determination is not made directly. The first step of the work generally consists in measuring the microwave parameters S_o of the 4-port junction with a network analyser [6]. These parameters have the same definition as the "topological" S parameters except the load impedance is fixed at Z_{c_o} generally equal to 50 Ω .

The second step is to go back to the Y parameters of the junction with such a matricial relation:

$$[Y] = \frac{1}{Z_{c_o}} ([1] + [S_o])^{-1} \cdot ([1] - [S_o]) \quad (9)$$

with [1]: the unit matrix.

One can then derive the [S] topological matrix, considering the local characteristic impedance matrix $[Z_c]$ of the connected lines:

$$[S] = ([1] - [Z_c][Y]) \cdot ([1] + [Z_c][Y])^{-1} \quad (10)$$

Figures 7a,7b,7c illustrate as an example the variation of S_0 , Y and S parameters between port 1 and port 3.

It must be specified that when the length of the lines becomes greater than the aperture size, the B.L.T. equation formalism gives the opportunity to find the parameters in the actual reference plane of the junction.

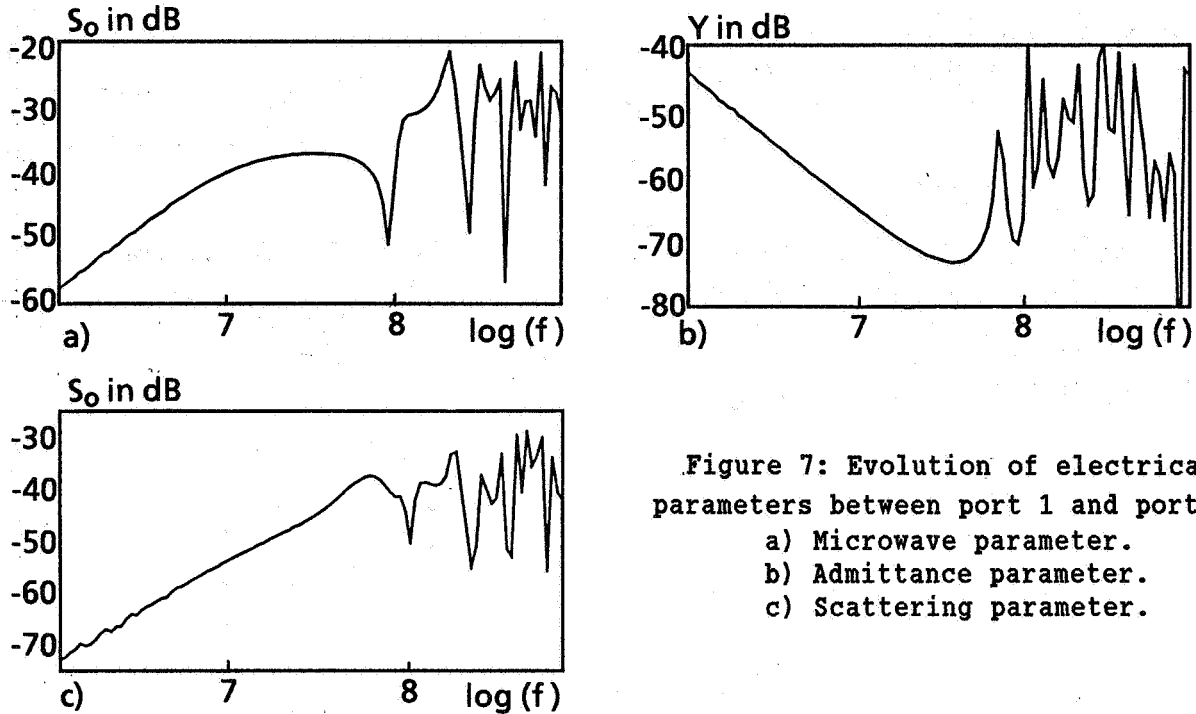

Figure 7: Evolution of electrical parameters between port 1 and port 3.

- a) Microwave parameter.
- b) Admittance parameter.
- c) Scattering parameter.

3.2. MODELING OF THE FIELD TO WIRE COUPLING

For this case, one must consider the geometrical configuration represented in figure 8. The upper wire in volume I has disappeared and has been replaced by an external electromagnetic plane wave. If the aperture is short circuited, this wave creates, short circuit electric E_{sc} and magnetic H_{sc} fields on it. The aperture must be supposed small enough to consider that the distribution of the fields is homogeneous.

Then the question can be asked what should the characteristic of the fictive wire in volume I be to create such an electromagnetic field distributions. For this, the E.M. fields created by a wire on a conductive plane can be calculated. According to the notations of figure 8, we have:

$$\vec{E}_{sc} = - \frac{V Z_0}{\pi Z_c} \frac{d}{d^2 + y^2} \vec{e}_x \quad (11)$$

and

$$\vec{H}_{sc} = - \frac{I}{\pi} \frac{d}{d^2 + y^2} \vec{e}_y \quad (12)$$

where Z_c is the characteristic impedance of the wire, Z_0 the impedance of the medium.

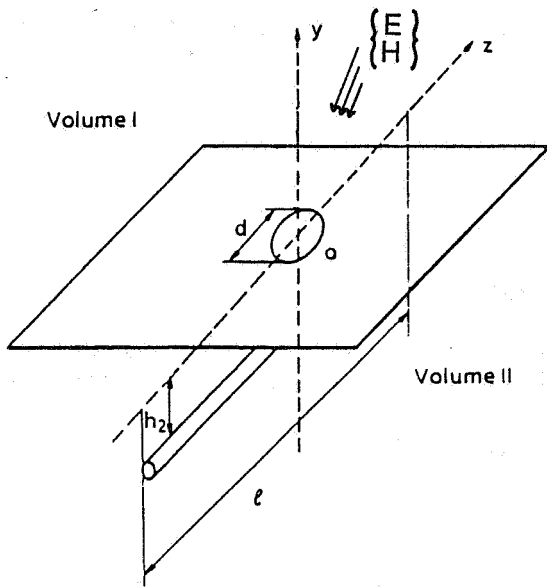

Figure 8: Coupling of a plane wave and a wire located under an aperture.

At each extremity (see figure 9), two orthogonal references can be created: $(\vec{e}_{x1}, \vec{e}_{y1}, \vec{e}_{z1})$ at port 1, $(\vec{e}_{x2}, \vec{e}_{y2}, \vec{e}_{z2})$ at port 2. The short circuit fields \vec{E}_{sc} and \vec{H}_{sc} can be expressed according to these new directions and become respectively $\vec{E}_{sc1}, \vec{H}_{sc2}$.

If I is introduced, an index dealing with volume I including indices 1 and 2, the topological wave for the fictive wire is defined by:

$$W_I^\pm = V_I \pm Z_{cI} I_I \quad (13)$$

Figure 9: Electromagnetic field created by a wire on a conductive plane.

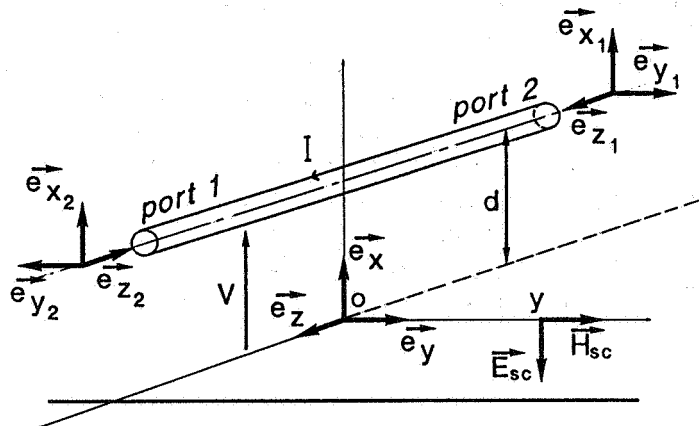

where + or - indicates incoming and outgoing waves.

From (11) and (12), defining an equivalent length l_{eq} by:

$$l_{eq} = \frac{Z_c}{Z_o} \frac{d^2 + y_o^2}{d} \quad (14)$$

($y = y_0$ at the center of the aperture), and a topological field wave W_{scI}^{\pm} by:

$$W_{scI}^{\pm} = E_{scI} \pm Z_0 H_{scI} \quad (15)$$

a new scattering equation involving the observables at each port of the junction is derived:

$$\begin{pmatrix} W_{scI}^{-} \\ W_{II}^{-} \end{pmatrix} = [S'] \begin{pmatrix} W_{scI}^{+} \\ W_{II}^{+} \end{pmatrix} \quad (16)$$

If $[S]$ is the scattering matrix dealing with the coupling of the fictive wire and the wire in volume II, defined in 4 blocks as in (8), it can be seen that $[S']$ in relation (16) is equal to:

$$[S'] = \begin{bmatrix} S_{I,I} & -S_{I,II}/l_{eq} \\ -S_{II,I} * l_{eq} & S_{II,II} \end{bmatrix} \quad (17)$$

As the scattering parameter definition needs to have a ratio V/I equal to Z_c , it is seen that the ratio $E(y)/H(y)$ remains equal to Z_0 . So, by adjusting the value of the medium impedance, it is possible to simulate any direction of the incident plane wave.

In fact, a single wire can be shown as an approximate tool to simulate a plane wave but as a convenient system for testing a structure. One could also think of measuring the scattering parameters when the wire in volume I is replaced by a conductive plane, thereby defining a stripline.

4. APPLICATION OF THE TOPOLOGICAL CONCEPTS ON A SCALE MODEL

CHARACTERIZATION OF THE INJECTION

The previous results are applied on a scale model ($1/10^{th}$) of the C160 Transall aircraft. Figure 10 shows the experimental set-up. Several wires (in dotted lines) run inside the structure and the external coupling paths are essentially constituted by two apertures 1 and 2.

An external wire excitation is chosen as in II.1, II.2 and II.3, but to maintain a constant characteristic impedance, the wire is replaced by a coaxial cable unshielded at the level of the apertures. This convenient means of excitation allows to easily choose the aperture to be irradiated. The frequency range can reach up to 100 MHz with less than a 3 dB variation and Z_c remains equal to 50Ω except at the aperture level [7].

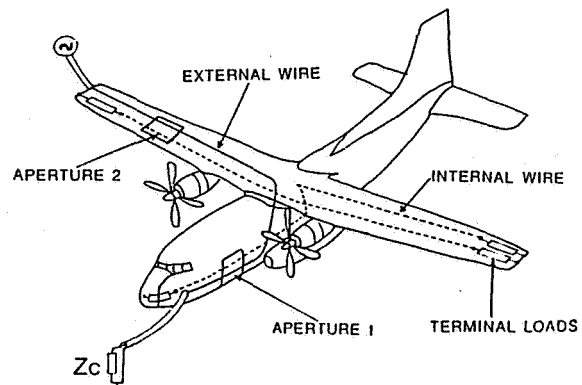

Figure 10: External and internal wire location on the scale model.

HIGH FREQUENCY MODELING OF INTERNAL COUPLINGS

If interference precalculations are to be made, it is necessary to make circuit modelings of the couplings. This can be done using powerful personal computer codes such as "Touchstone". Such a code provides the opportunity to perform curve optimizations: specific goals are introduced and the adjustment of pertinent parameters is made automatically.

The electrical characterization of the scale model is made in a topological sense which means that each part is studied independently. As an example, figure 11 represents the different ports where measurements are performed on the wing. Considering this configuration as a four port system the S_{ij} parameters have been obtained and simultaneously, a modeling of the electrical circuit has been done. To take resonances in the aperture into account, several generator cells have been provided as reported in figure 12. Finally, a comparison between measured and modeled transfer functions can be performed using the B.L.T. equation. Figure 13 gives an example of the good agreement between both results at port 4. Consequently, we are now able to foresee the consequences of any modification on this geometry, by fitting the value of the pertinent circuit elements.

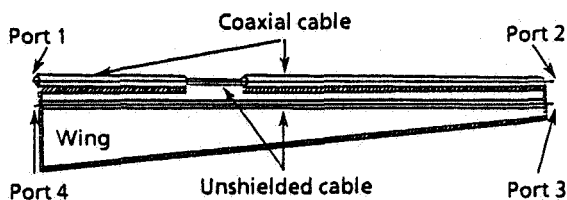

Figure 11: Different ports of measurement on a wing.

Figure 12: Electrical modeling of the coupling through the aperture taking resonances into account.

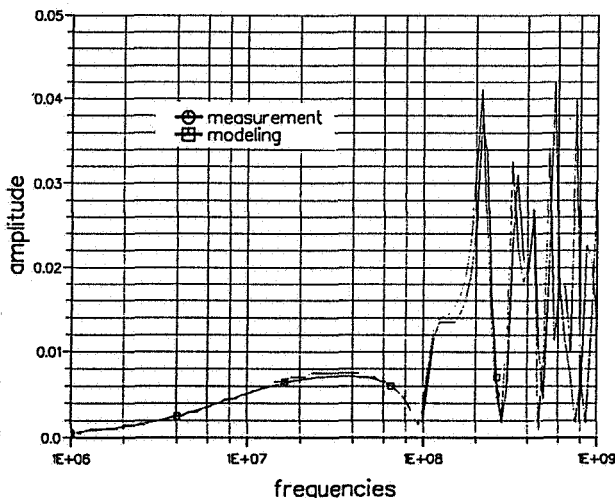
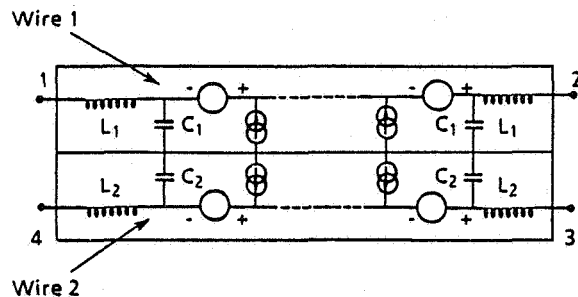

Figure 13: Comparison between measured and modeled transfer functions on port 4 of the wing.

5. CONCLUSION

The electromagnetic topology must lead to the definition of an electromagnetic design tool. Nowadays, several methods must be developed at the same time: the fundamental concepts, elaborated by C.E. Baum; a quantitative way dealing with the use of graph concepts. Another interesting method, combining the two previous ones, is to generalize the multiconductor transmission line network theory in the aim of integrating well known electromagnetic couplings in the formalism.

The treatment of an aperture as a four-port junction is an aspect of this development, and has proved itself to be a convenient means to test internal electromagnetics. In the future, other aspects such as antenna couplings and current diffusion will be treated.

In conclusion, the B.L.T. equation coupled with the multiconductor transmission line network formalism could become, in the future, the basis of an electromagnetic design tool.

REFERENCES

- [1] C.E. Baum,
Theory of electromagnetic interference control. Interaction Notes, Note 478, 28 December 1989.
- [2] C.E. Baum, T.K. Liu, F.M. Tesche,
On the analysis of general multiconductor transmission line networks. Interaction Notes, No 350, November 1978.
- [3] F.C. Yang, C.E. Baum,
Electromagnetic Topology: measurements and norms of scattering parameters of subshields. Electromagnetics 6, 47-59, 1986.
- [4] K.S.H. Lee,
Principles, techniques and reference data (a complete concatenation of technology from EMP interaction notes). EMP Interaction Notes, 2.1, 1980.
- [5] J.P. Parmantier, G. Labaune, J.C. Alliot, P. Degauque,
Electromagnetic coupling on complex systems: Topological approach. La Recherche Aéronautique, n°1990-5.
- [6] J.P. Parmantier, G. Labaune, J.C. Alliot, P. Degauque,
Electromagnetic Topology: Junction characterization methods. La Recherche Aéronautique, n°1990-5.
- [7] J.P. Parmantier, J.P. Aparicio,
Electromagnetic Topology: coupling of two wires through an aperture. Proceedings, Zurich, 1991.