

N91-32713

## LIGHTNING MAPPING SYSTEM

C. Lennon and L. Maier

National Aeronautics and Space Administration  
John F. Kennedy Space Center, Florida

### ABSTRACT

A new Lightning Detection and Ranging (LDAR) System is being implemented at the Kennedy Space Center, Florida. The first operational use is expected in the late summer of 1991.

The system is designed to map the location of In-Cloud and Cloud-to-Ground Lightning based on the Time Of Arrival (TOA) of electromagnetic radiation. The system detects VHF radiation and is designed to map the volumetric extent of lightning. The system implements two independent antenna arrays to provide a fast data quality check, as necessary for a real-time warning system. The system performance goals and a comparison with a similar system implemented in the mid 1970s is made.

### INTRODUCTION

In this paper we describe a Lightning Mapping System that is under development at the John F. Kennedy Space Center. The system is an improved version of a system that was used during the Thunderstorm Research International Program (TRIP 76-78)[1]. The final form of the original system is described by Poehler and Lennon in NASA Technical Memorandum [2]. This early NASA system used digital waveform recorders and digital computers to provide a near real-time display of lightning pulse locations. The NASA system was an automated version of a system developed by Proctor[3] which determined the time differences manually from film records.

### PRINCIPAL OF OPERATION

Lightning discharges produce a series of broadband VHF pulses. By detecting the TOA of these pulses, at widely separated sites, the location of the source of radiation can be computed.

The coordinates of the receiving sites are listed and plotted on a map of the Kennedy Space Center (KSC) in Figure 1. Lightning-produced RF pulses are received at the remote sites and are processed by Log Video Detectors (LVDs). The resulting series of video pulses are transmitted to the Central LDAR site (Site 0) by microwave links. The physical configuration of the system assures that the direct RF pulses

will arrive at the Site 0 prior to the retransmitted pulses from the remote sites. Advantage is taken of the early arrival of the pulses at the Site 0 to trigger the system.

When a pulse exceeds a threshold at the Site 0 the system is triggered, opening a data analysis period which extends for 100 microseconds. During this analysis window the system determines the time of occurrence (apparent TOA) of the largest amplitude pulse for each of the seven data channels. At the end of the analysis period the time and amplitude data for each channel will be collected, and the event will be tagged with the time of day to the nearest microsecond. This data will be buffered and the system will be re-armed within 10 microseconds. Figure 2 illustrates the time tagging process using a simplified series of lightning pulses. At the completion of the data gathering process data is transmitted to a group of computers for testing, calculation of the source locations, and display.

### COMPUTER CONFIGURATION

A block diagram of the equipment located at the LDAR Site 0 is shown in Figure 3.

The function of the display computer is to develop software for the VME system, to load both operating system and software for the VME system, and to provide lightning location displays. The display computer will receive source locations from the VME system for display.

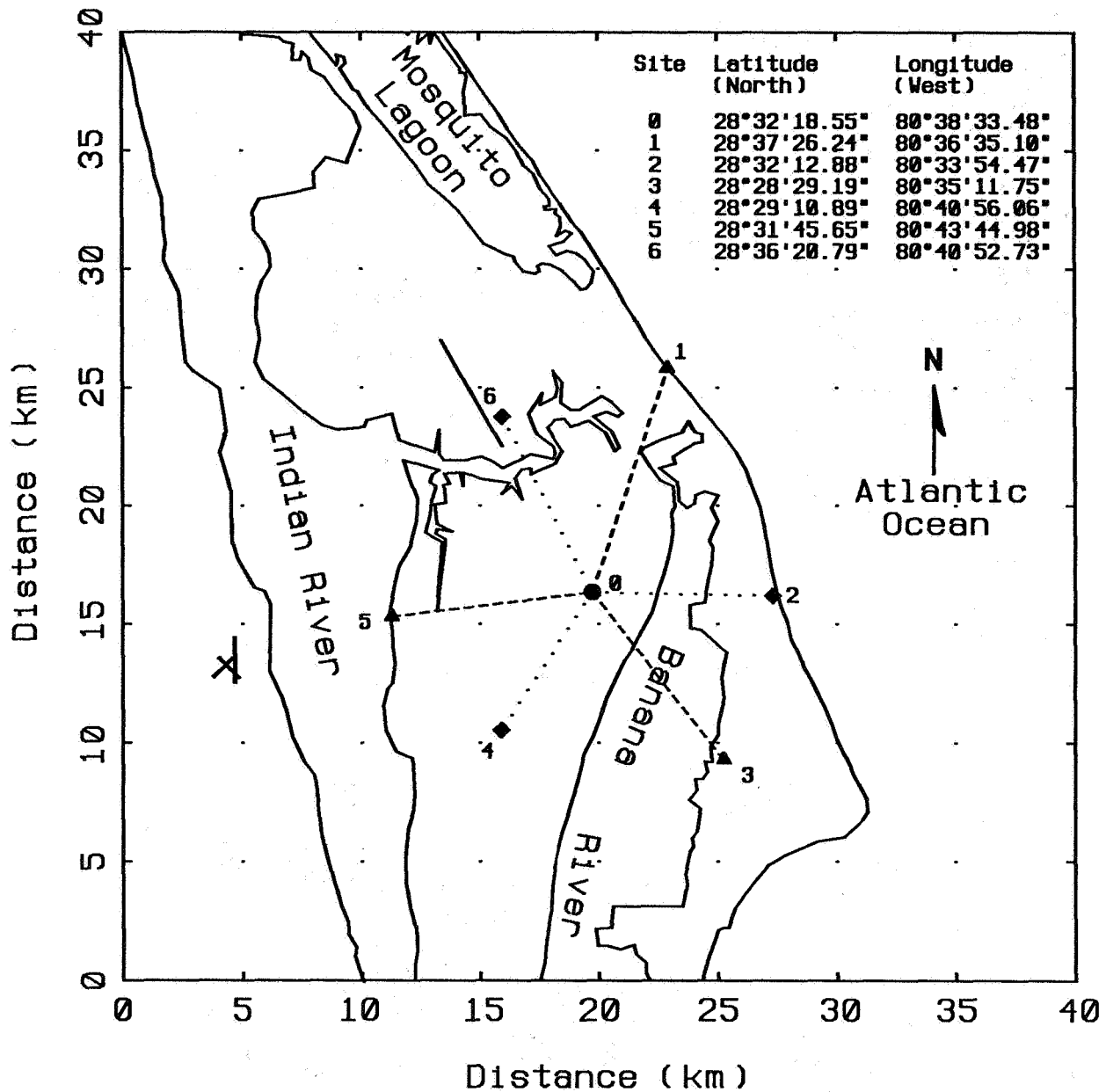

Figure 1. LDAR site locations (see text for further description).

#### DATA OUTPUT/DISPLAY

The function of the VME System is to ingest TOA data, perform validity tests, compute X, Y, and Z coordinates, store data on magnetic tape, and to transmit X, Y, Z-coordinate data to the display computer. The VME System is housed in a 20-slot card cage and uses multiple on-board computers for parallel processing of the TOA data. In addition the VME System is interfaced to a Digital Audio Tape (DAT) for mass storage of the TOA raw data (1.2 Gbytes).

The LDAR system will provide output data for displays in the following two formats.

First, the display computer will generate a near real-time display. This display will be converted to the National Television Standards Committee (NTSC) format and will be distributed to KSC and the Air Force's Operations Control Center by a combination of wideband cable and operational television circuits.

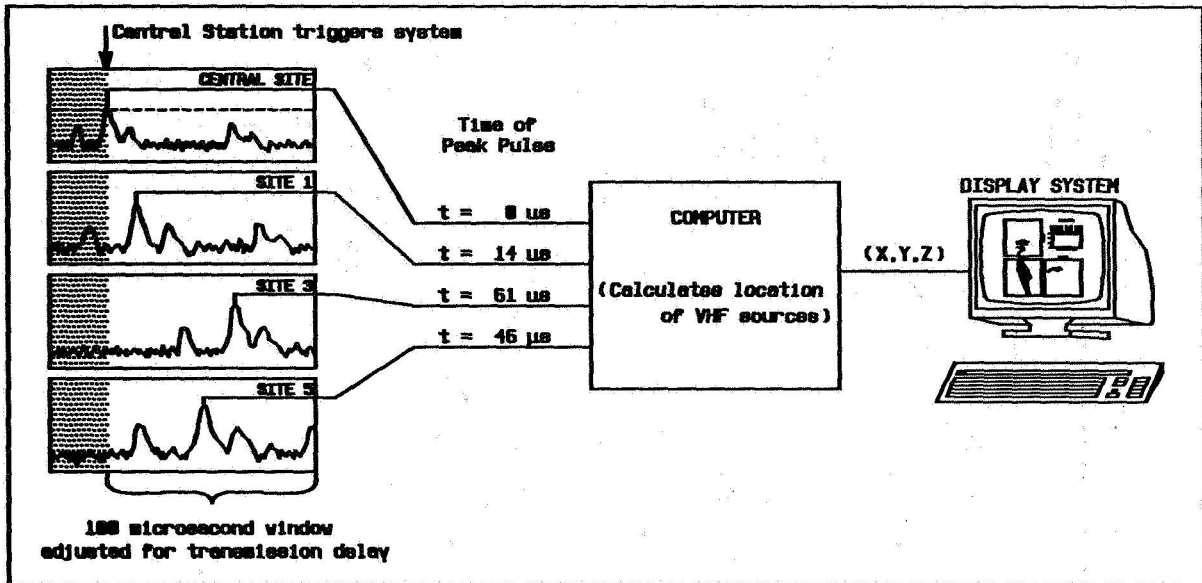

Figure 2. Time tagging process.

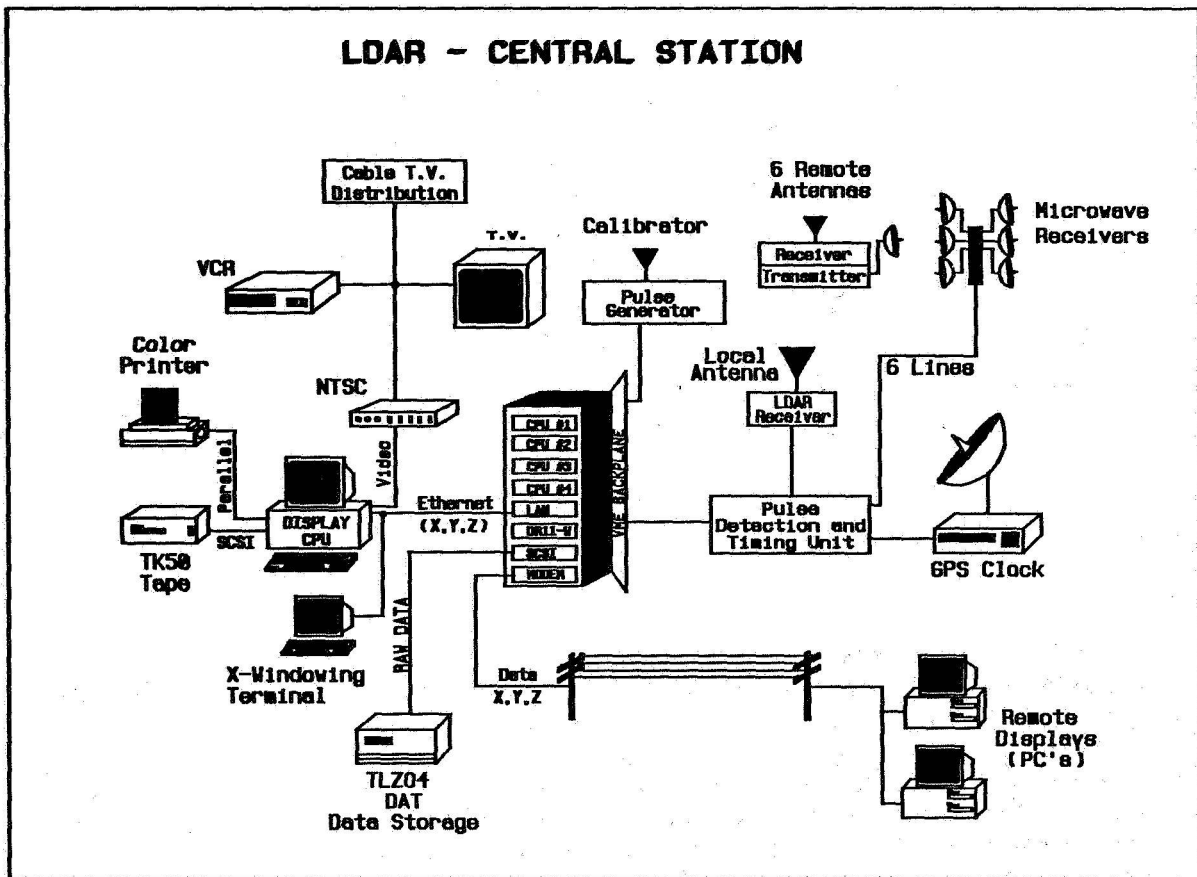

Figure 3. Block diagram of central station.

Secondly, the VME System will transmit the X, Y, Z coordinates of lightning sources. This data will be broadcast as an RS-232 format signal over a 19-gauge wire pair. This signal will be available to anyone having access to the KSC communications system. This arrangement will allow users to tailor displays to meet their requirements (e.g., a Plan Position Display, PPD, centered on Complex 39A.)

The display generated for dissemination by the local cable television network is unique, and the format of

the display is shown in Figure 4. The PPD portion of the display (A) is at the lower left of Figure 4.

This part of the display shows a map of the KSC area that is centered on the location of the LDAR Site 0 (X=0, Y=0, Z=0). The scale of the map can be changed as an operator function. When a lightning pulse is detected its location will be computed in the X, Y, Z coordinate system. The X, Y location of the point will be plotted as a point in the PPD portion of the display.

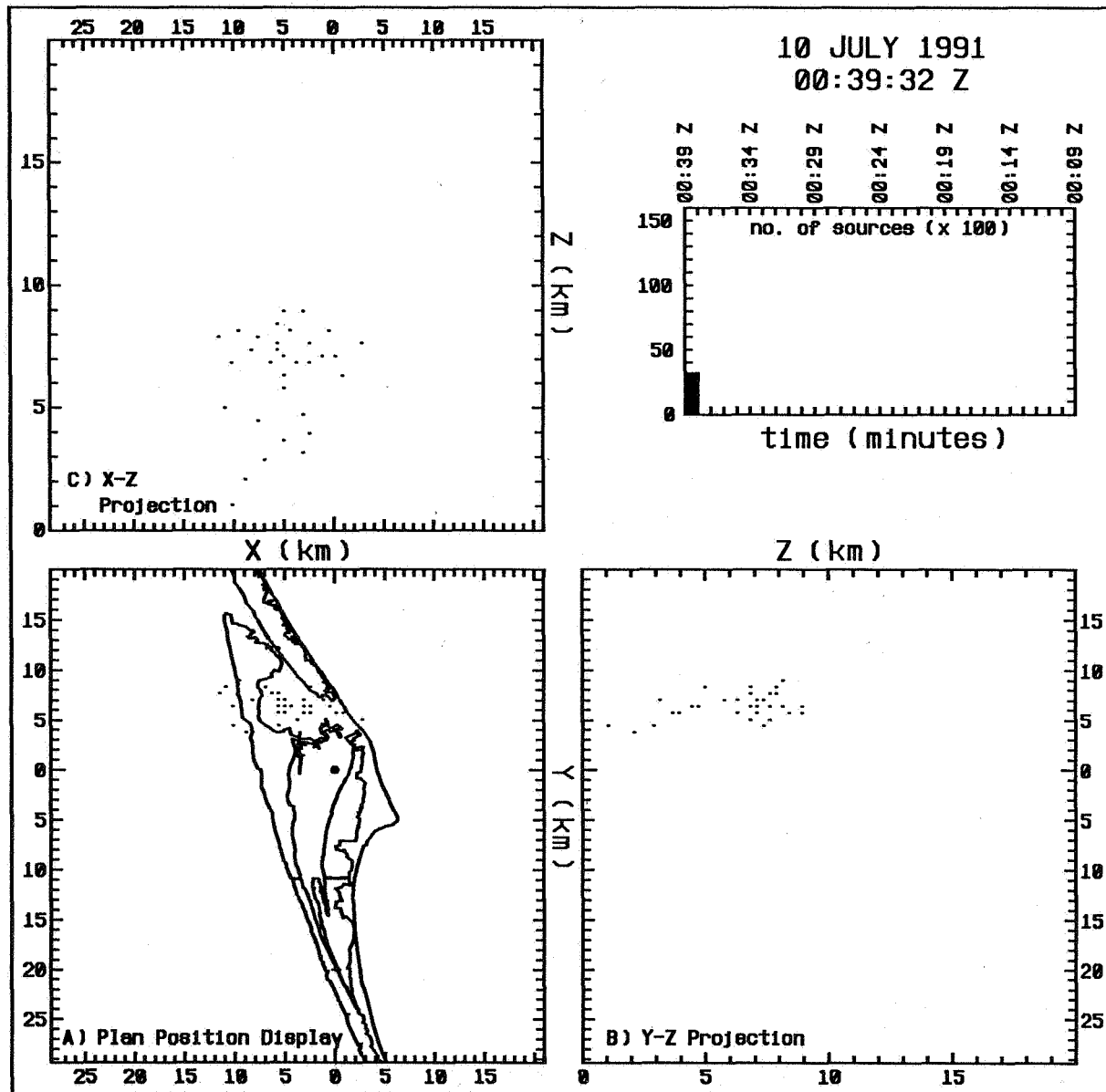

Figure 4. LDAR real-time display (see text for description).

Coupled with the PPD are two more displays that show the X, Z and Y, Z projections of the same points plotted on the PPD. These displays give the operator (observer) a view of the height profile of the discharges as seen by an observer located west of the event (Display B) or south of the event (Display C). The relationship between projections for 5 VHF sources is illustrated in Figure 5.

An additional sub-display is provided in the upper right-hand corner of the composite display (Figures 4

and 5). This display is a histogram depicting number of pulses per unit of time. The unit size of the ordinate axis (events per unit of time) will be a variable that is compatible with the lightning activity and display capacity.

Lightning pulses that fall outside of the display coverage will not be plotted or added to the histogram. A cursor will flash indicating that the system is detecting lightning activity outside of the selected display area.

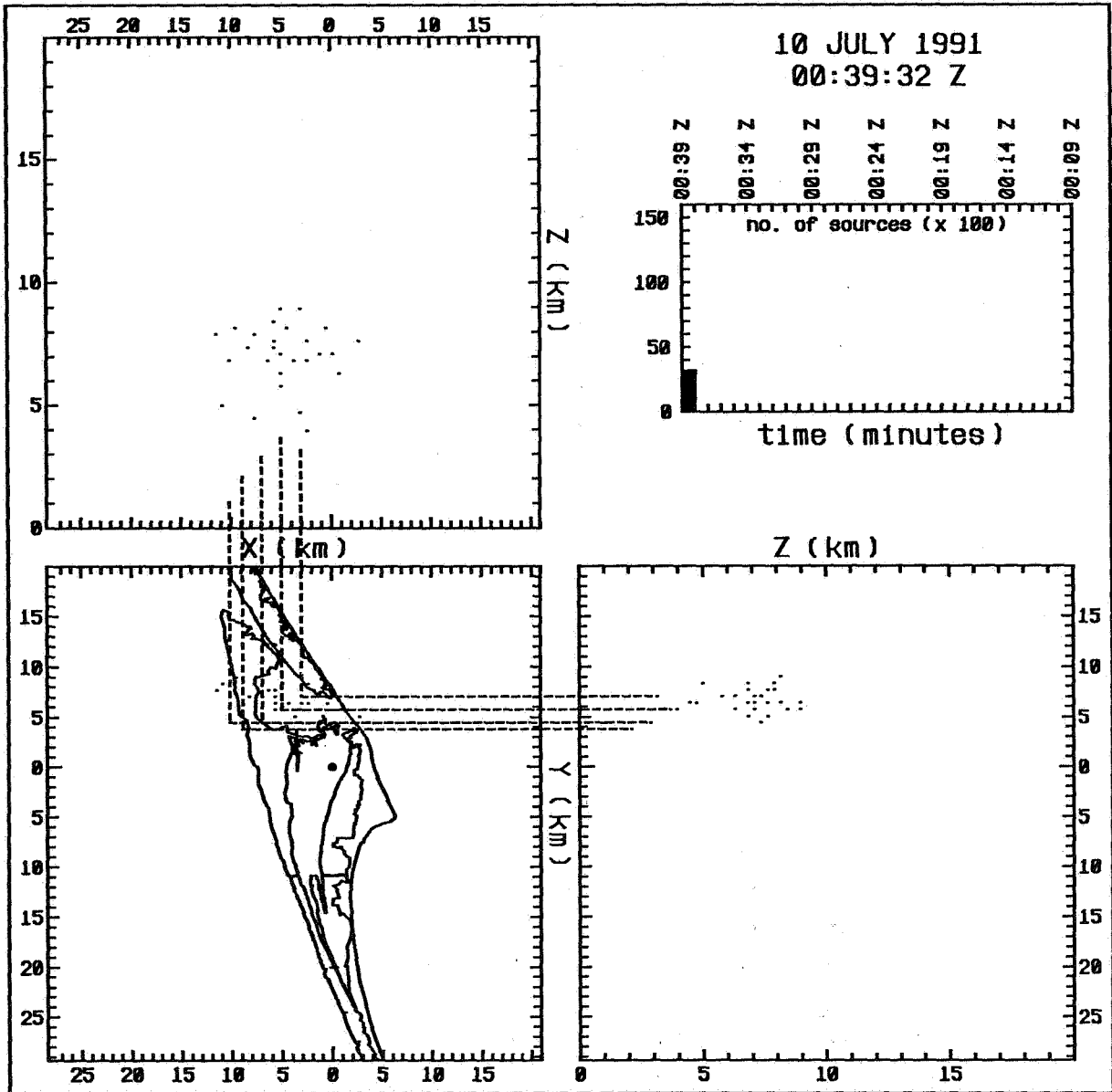

Figure 5. Demonstration of inter-relationship of projections on the LDAR real-time display.

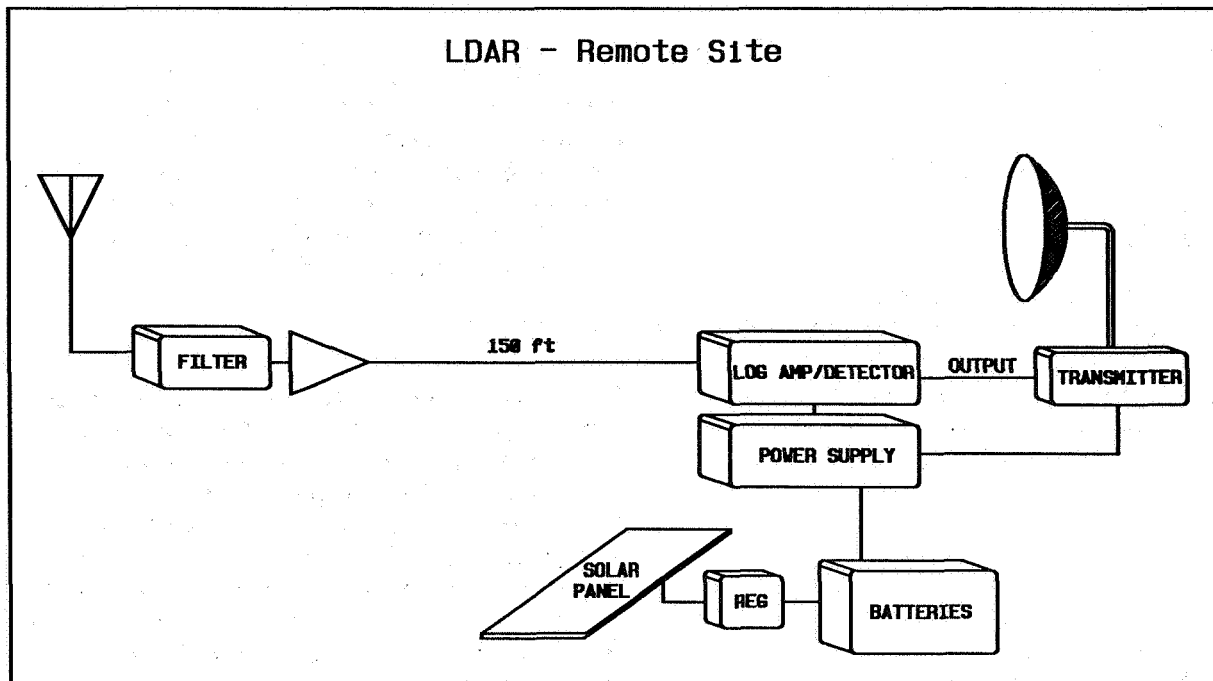

Figure 6. Block diagram of LDAR remote site.

Another feature to be added to the display is the use of color to represent temporal variations in the data. The most recent data will be displayed in bright red with earlier events being displayed in yellow, blue or green. The time interval assigned to each color will be determined during the check-out and certification phase of system development.

#### LDAR RECEIVERS/ANTENNA

A block diagram of an LDAR receiver is shown in Figure 6. The basic LDAR receiver is built around an Adams Russel Model 1CLA351 logarithmic amplifier. Amplifier specifications are provided in Table I.

TABLE I. Log amplifier specifications.

Frequency range	60-300 MHz
Input Dynamic Range	75 dB minimum
Tangential Sensitivity	-75 dBm
Rise Time	10 Nanoseconds (maximum)
Function	Logarithmic Video Detection
Linearity (Log Output)	$\pm 1.5$ Db

The frequency response of the receiving system is limited by the addition of a filter between the logarithmic amplifier and the antenna. Two sets of filters are available for selecting a system operating frequency of either  $63 \pm 3$  MHz or  $225 \pm 3$  MHz. This design easily accommodates changes to the operating frequency in the range between 60 MHz to 300 MHz by changing the input filter.

A small in-line amplifier is located near the antenna. This amplifier protects the input of the logarithmic amplifier, and it increases the signal level on the transmission line by 10 dB. By increasing the signal level on the transmission line, the effects of stray signal pickup are minimized. Power for the input amplifier is supplied via the transmission line.

The receiver package is located (adjacent to the Microwave transmitter) near the top of a 52-foot power pole. By locating the receiver close to the transmitter the possibility of stray signal pickup on the video line connecting the two is minimized.

The sensor for the receiver system is a broadband antenna covering the frequency range of 60 to 300 MHz. The antenna is specified to have hemispherical coverage, and is left hand circular polarized  $\pm 1$  dB. By using a circular polarized antenna the variation in

signal amplitude, due to variation in the polarization of the radiating source, will be minimized.

## DATA QUALITY

### SITE SELECTION

To be a useful part of a lightning warning system, the LDAR must have a high detection ratio and a near zero false alarm rate. To insure a high detection ratio the operating frequency and the locations of the receiving sites were carefully selected. Some of the criteria used in site selection are listed in Table II.

---

Table II. Site selection criteria.

---

1. Maintain "Y" Configuration
  2. Good Accessibility
  3. Located On Government Property
  4. Away From Above Ground Power Line
  5. Away from Industrial Sites
- 

### FREQUENCY SELECTION

The ambient RF signal level between 60 and 72 MHz was measured at Site 0 and at each remote site. All sites were found to have acceptable background signal levels.

An initial operating frequency of 63 MHz was chosen. This frequency is in the center of the band allocated for television Channel 3. Since there is no local Channel 3 television assignment, this frequency range is protected from local users (100 miles).

The number of lightning-produced VHF radiation impulses, as reported by Oetzel[4], peak between 50 and 100 MHz at  $10^4$  pulses-per-second, and decrease rapidly above 100 MHz. Based on these data and on operation of the earlier LDAR system at this frequency, 63 MHz was chosen as the initial operating frequency.

### TIME DELAYS

There are several system design parameters that have a direct effect on the location accuracy of the system. Some of the obvious critical parameters are: signal digitization interval, system time delays, time delay stability, and system bandwidth. The system

bandwidth (6 MHz) and digitization window ( $10^{-8}$  seconds) are fixed by design. The system delays are a function of site location, cable lengths, individual component bandwidths, and propagation delays. To insure optimum system performance, these delays must be measured and subtracted from the TOA data. To measure these delays a system calibrator has been included in the design.

### CALIBRATOR

The system calibrator consists of a high powered impulse generator AVTECH Electrosystem Ltd. Model # AVB2-C-NASA1. This generator is capable of producing a 400 volt peak-to-peak pulse into a 50 ohm load. The shape of the waveform simulates a single cycle of a 63 MHz sine wave. This signal will be applied to a vertically polarized antenna, located on top of the microwave tower at the LDAR Central site. This signal will be received at the remote site and the resulting video pulses will be transmitted back to the central site by microwave links. The time interval between the arrival of the pulse at the central site receiver and the arrival of the pulses at the output of the microwave receivers will be measured by the LDAR data processor. This is the same technique used to measure pulses produced by lightning.

Since the location of the calibrator antenna and the remote station antennas are known ( $\pm 1$  meter), the time delay to each station can be calculated. These propagation time delays are constant and will be measured by the LDAR system when the calibrator is turned on. The measured time delays will be compared to the calculated propagation delays, and the differences will be determined and entered into the LDAR software as constants.

During the system checkout and certification, the calibrator will be used at least daily to verify proper system operation and system time delay stability. Based on this data, a System Calibration Interval will be established. The calibrator provides a ready means for system function test. When the calibrator is turned on a series of points will be displayed at the center of the primary LDAR display.

### SYSTEM REDUNDANCY

The LDAR System is actually two systems. LDAR Site 0 and remote sites 1, 3 and 5 comprise System 1; and site 0 and remote sites 2, 4 and 6 comprise System 2. Since Site 0 is common, both systems operate in

TABLE III. System specifications.

Operating Frequency Initial Implementation	60-300 MHz 63 MHz
Data Band width	6 MHz
Data Collection Rate	$10^4$ events/second (maximum)
Data Window	100 microseconds
Number of Stations	6 Remote 1 Central
Remote Station Power Operating reserve	Solar Panel with batteries. 3 days with overcast sky.
System Location Accuracy Within Network	X and Y $\pm$ 30 Meters Z $\pm$ 90 Meters
Outside Network	Basic Accuracy $X D^2/6$ D = Distance in miles
Processing Efficiency (i.e., the number of source locations that pass all data quality criteria)	75%
False Alarm Rate	0
Data Storage:	All raw data stored on Digital Audio Tape (1.2 GByte capacity)
System Outputs:	1. Television NTSC Compatible Display 2. Pulse source location broadcast on RS-232 Circuit.
Central Station Power	120/208 Vac 60 Hz With uninterruptible Power System (UPS) backup for a one hour power outage. System air conditioners are not on the UPS.
System Timing:	All trigger events will be time tagged to nearest microsecond. Timing source is a GPS receiver.

synchronization. The coordinate data from System 1 is designated as  $X_1$ ,  $Y_1$ , and  $Z_1$ , and the coordinate data from System 2 is designated  $X_2$ ,  $Y_2$ , and  $Z_2$ . By comparing the coordinate data from the two systems ( $D_1 = D_2 \pm K_1(D)$ ,  $Z_1 = Z_2 \pm K_2(D)$ , where  $D = [X^2 + Y^2]^{1/2}$  is the horizontal distance to the source and  $K_1$ ,  $K_2$  increase as a function of distance from Site 0) wild points can easily be detected. Initially, the sys-

tem will not display data that does not pass the comparison test, although the data will be archived. Future development may include calculations of coordinates using other remote site combinations, i.e. 0, 1, 3 and 6. Experience has shown that the coordinate comparison is a very stringent test that assures that bad data will not be provided for operational use.



## COMPARISON WITH EARLIER LDAR (LDAR-1)

The principal of operation and the site locations for the two systems are essentially the same. The major differences are discussed below.

### DATA TRANSMISSION FROM REMOTE SITES

LDAR-1 used a combination of wideband video circuits and microwave links. The new system uses all microwave links.

### REMOTE STATION POWER

LDAR-1 used commercial A.C. power with battery back-up at all but one site. One microwave site used batteries which were charged by a wind driven generator. In the new system, all remote sites are operated from solar charged batteries.

### CALIBRATOR

LDAR-1 used a spark gap transmitter, which was located on the roof of the Vehicle Assembly Building. The new system uses a solid state pulse generator to drive an antenna, located on the microwave tower at the central site.

### WAVEFORM PROCESSING

LDAR-1 used eight Biomation Model 8100 waveform recorders, operated in parallel, to digitize and store the waveforms of the RF pulses. The stored data was dumped to a parallel processor that determined the time to the peak of the largest pulse in each waveform. The new system does not use waveform recorders. The new system uses a special NASA built processor that determines the time to peak, and peak amplitude on the fly.

### DATA COLLECTION RATE

LDAR-1 could process a maximum of 200 sets of waveforms per second. The present system is designed to determine the peak amplitude and time delays for  $10^4$  waveform sets per second.

### DATA COMPUTATION

LDAR-1 used a mini-computer to ingest data and compute the coordinates of the pulse sources. The coordinates were transferred to a second computer

for display and storage. The programming language was Basic with equipment drivers written in Assemble language. The new system will utilize four single board computers to ingest and parallel process the data. The output of the processors will be transmitted to a work station for display generation. The primary programming languages will be Fortran and "C".

## DEVELOPMENT SCHEDULE

The LDAR system is under construction. Barring unforeseen procurement or development problems, the system should be ready to record data by May of 1991. The software required to produce an elementary real-time display should be available by July 1991.

## OPERATIONAL RESEARCH

The LDAR System is an excellent tool for locating the source of VHF pulses produced by the lightning discharge process; but considerable work is needed to determine the best utilization of LDAR data in support of ground and launch operations at the Cape Canaveral Forecast Facility (CCFF).

LDAR will initially operate at 63 MHz, in the range between 50 and 100 MHz where VHF pulses are most numerous according to Kimpara [4]. Since the best operational frequency is not yet known, the current system is designed to operate between 60 and 300 MHz. The design of the present LDAR also allows one system to be operated at 63 MHz and the second system to be operated at 225 MHz. By operating the system at two frequencies simultaneously, it should be possible to determine whether radiation at 63 MHz and at 225 MHz originate from different regions of the cloud. This in turn will determine the optimum operational configuration.

The LDAR data should also be useful in studying the following operational concerns:

1. Time From First Detected VHF radiation (or any other easily identifiable meteorological signature) to occurrence of first ground strike.
2. Number and characteristics of lightning-producing storms that do not produce ground strokes.
3. Lightning Hazard Distance - Distance from centroid of VHF radiation or radar echo to ground contact point.

4. Tracking of electrical storms.
5. Definition of the end of electrical activity.
6. Preferred location of storms.
7. Climatological data base.
8. Comparison of VHF source volume with radar volume.
9. Lightning rate as a predictor of storm behavior.

#### FUTURE SYSTEM ENHANCEMENTS

After successful implementation of LDAR, future enhancements to both hardware and software are under consideration. Several are described below.

The current system uses the peak pulse in a 100-microsecond window from each of the 7 sites for calculating the VHF source location. The system relies on running two systems in parallel to compare data and reject erroneous locations due to using an incorrect pulse. A future enhancement would employ cross-correlation techniques in either hardware or software to assure the same pulse is identified for each site.

A simpler technique may be to use more than two site combinations to calculate pulse location. This would provide assurance that the pulse was located correctly and provide receiver statistics that may help identify maintenance needs. This technique may also be used with cross-correlation techniques to provide an indicator of system accuracy for the location of each radiation source

Another enhancement would lengthen the 100-microsecond window and overlap it with the subsequent windows at each of the remote sites to assure that the peak pulse in the window at site 0 will be available in the windows of each of the remote sites.

To improve vertical resolution, elevation angle measured from an interferometer at site 0 may be used.

#### ACKNOWLEDGEMENTS

Special recognition goes to Thomas Britt who designed and built the special hardware required to determine the TOA of the RF pulses. Also, we wish to recognize the special efforts to the technicians, Co-ops, coordinators and procurement personnel who have overcome many obstacles to make this project a reality.

#### REFERENCES

1. Pierce, E. T., The Thunderstorm Research International Program (TRIP)-1976, *Bull. Am. Meteorol. Soc.*, 57, 1214-1216, 1976.
2. Poehler, H. A. and Lennon, C. L., Lightning Detection and Ranging System, LDAR, System Description and Performance Objectives, NASA Technical Memorandum 741005, 1979.
3. Proctor, D. E., A hyperbolic system for obtaining VHF radio pictures of lightning, *J. Geophys. Res.*, 76, 1478-1489, 1971.
4. Oetzel, Pierce, Radio Emissions From Close Lightning, *Planetary Electrodynamics*, International Conference on the Universal Aspects of Atmospheric Electricity, Chapter IV, Pg 558, 1969.