

DESIGN OF LIGHTNING PROTECTION FOR A FULL-AUTHORITY DIGITAL ENGINE CONTROL

M. Dargl, E. Rupke, K. Wiles
Lightning Technologies, Inc., USA

ABSTRACT

This paper describes the steps and procedures necessary to achieve a successful lightning-protection design for a state-of-the-art Full-Authority Digital Engine Control (FADEC) System. The engine and control systems used as examples in this paper are fictional, but the design and verification methods are real. Topics discussed include applicable airworthiness regulations, selection of equipment transient design and control levels for the engine/airframe and intra-engine segments of the system, the use of cable shields, terminal-protection devices and filter circuits in hardware protection design, and software approaches to minimize upset potential. Shield terminations, grounding and bonding are also discussed, as are the important elements of certification and test plans, and the roles of tests and analyses. The paper includes examples of multiple-stroke and multiple-burst testing. The paper concludes with a review of design pitfalls and challenges, and status of applicable test standards such as RTCA DO-160, Section 22. This paper will be presented in two parts; Part I - Design, and Part II - Verification.

1.0 INTRODUCTION

Developed in the early 1970s for military aircraft, electronic-flight and engine-control systems have found increasing application in the commercial fleets of the world. Systems such as Full-Authority Digital Engine Control (FADEC) and Fly-By-Wire (FBW) not only perform flight-critical and essential functions, but do so independently of mechanical or hydraulic backup. Currently operating commercial transport aircraft such as the Airbus A320, McDonnell Douglas MD-11, and Boeing B747-400 use full-authority electronics for engine control and some aspects of flight control. Other systems are under development.

Because FADEC and FBW systems are flight-critical, they are required by regulatory agencies to withstand the effects of a severe lightning strike to the aircraft. This paper describes and interprets the current airworthiness regulations and standards pertaining to lightning protection and provides a technical discussion of the steps that should be taken to achieve a successful protection design. This paper also reviews several design problems and ways to overcome them. Methods to verify adequacy of these designs are treated in a sequel paper [1].

2.0 DESCRIPTION OF SYSTEMS

Typical FADEC and FBW systems share many features that are important from a lightning-protection standpoint. In general, both types of systems are designed to convert pilot-input data, such as control stick or throttle-lever movement, into digital signals which are received by actuators at the appropriate engine controls or flight-control surfaces.

Both types of systems have similar configurations:

- The systems are widely distributed throughout the airframe, with controls in the cockpit electrically connected to actuators as far as the tail and wingtips.
- FADEC and FBW systems usually receive electric power from the aircraft power distribution buses, which are also distributed throughout the aircraft.
- The systems interface with cockpit displays, and often with general-purpose digital data buses.
- The systems are sometimes connected to externally mounted sensors and actuators.

Block diagrams of generic FBW and FADEC systems are shown in Figures 1 and 2. Figures 3 and 4 show typical locations of system components and interconnecting wiring within an aircraft and an engine, respectively.

A full FBW system controls the three main axes of flight - pitch, roll and yaw - by adjusting ailerons, rudder, elevators,

flaps, trim-tabs, etc. For each of the pilot's controls, the FBW system includes a force transducer that converts the pilot's stick, pedal or lever motion into electrical signals. These signals are transmitted to a computer and voter unit (CVU) which reads not only all the data being supplied by the pilot commands, but also data sent by aircraft motion sensors (including gyros and air-data probes) and control-surface position indicators. The CVU regularly consists of three or more separate processors operating on separate channels, sometimes asynchronously. The voter unit polls the independent processors for agreement.

This redundancy is a safety feature but it does not in itself provide adequate protection against lightning because lightning-induced effects appear simultaneously in all channels of interconnecting wiring and thus have the potential to damage components in all channels at once.

The CVU computes the optimum changes to make in the various control-surface positions in order to accomplish the pilot's commands and maintain pre-programmed flight parameters. In addition to the above connections, the CVU is also connected to the pilot's display panels and to the aircraft's main power systems, including one or more engine-driven generators and one or more batteries. The computer sends the appropriate electronic signals to secondary actuators near the control surfaces.

The secondary actuators (SA) translate the electrical signals from the CVU to mechanical motion of the flight-control surface. The SA will typically consist of an electrically activated servovalve to operate the hydraulically powered control-surface actuators. There are also differential transducers which provide the CVU and main cockpit display with feedback information on the position of the control surfaces.

FADEC systems also include cockpit controls and interfaces with other cockpit avionics, as well as engine-mounted components, which usually include the electronic control unit (ECU) whose function is to that of the CVU in an FBW system. Usually, a FADEC system is comprised of two channels, designated A and B, at each engine. The CVU interfaces with engine-mounted sensors and actuators, and with cockpit avionics. The interconnecting wire harnesses often follow different routes between engine and cockpit to protect the system against damage from an exploding engine, etc. This is referred to as *disbursed routing*. Instead of control surfaces, as found in FBW systems, FADEC systems typically control engine fuel flow, stator vane position, exhaust nozzle configuration, etc., to optimize engine performance and economy.

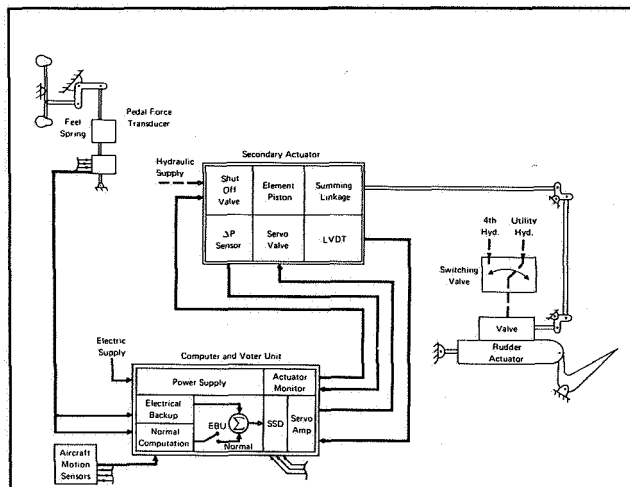

FIGURE 1 Typical FBW System

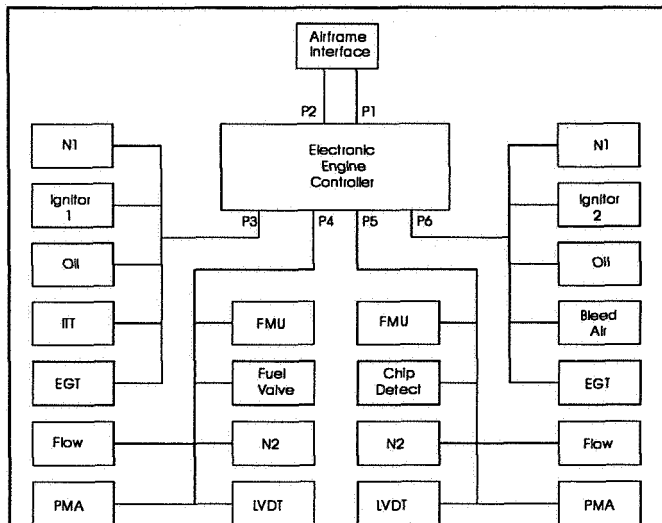

FIGURE 2 Typical FADEC Block Diagram

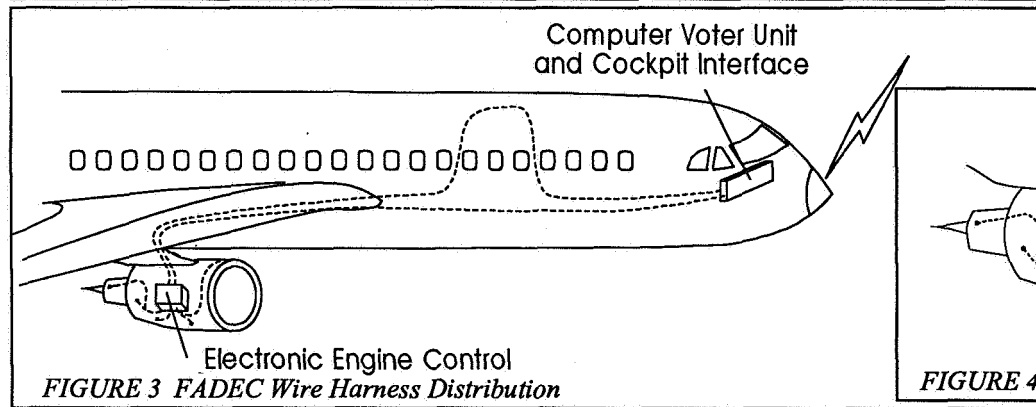

FIGURE 3 FADEC Wire Harness Distribution

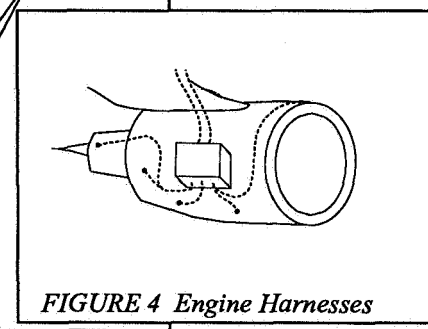

FIGURE 4 Engine Harnesses

Both systems provide many challenges to the lightning-protection engineer. The amount and length of interconnecting wiring harnesses makes them susceptible to lightning indirect effects, and the location of some components near aircraft extremities results in potential susceptibility to direct lightning effects. The magnitudes of induced transients are difficult to predict because of the difficulty of describing most wiring installations in circuit or mathematical terms that can be analyzed. These complexities make numerical modeling of the waveforms and currents which might be expected in the systems very difficult. Mathematical analysis currently can predict only orders of magnitude, which are of use in formulating design goals but inadequate for verification of all but the simplest of systems.

3.0 REGULATIONS

Airworthiness certifying authorities around the world assume that during the operational life of an aircraft, lightning strikes will occur. Over the years, the Federal Aviation Administration (FAA) has developed several Federal Aviation Regulations (FAR) [2] which pertain to lightning. These are listed in Table I, and include FAR 25.581, which states, for transport category aircraft: "The airplane must be protected against catastrophic effects of lightning." Of more particular interest to engineers concerned with electronic control systems is FAR 25.1309 which requires that "The equipment, systems, and installations whose functioning is required by this subchapter, must be designed to ensure that they perform their

intended functions under any foreseeable operating condition." While not mentioned by name in this regulation, lightning is considered a foreseeable operating condition. To preclude any question of the applicability of FAR 25.1309 to lightning protection, the FAA has required lightning protection of flight-critical and essential avionics through the imposition of *special conditions* and *issue papers*. A special condition is written by the FAA (or similar certifying authority in another country) expressly for a particular aircraft (or modification) and has the same force and effect as a published regulation. An issue paper delineates a safety issue of particular concern to the FAA, and requests the applicant to address this issue and respond to the FAA with details. Thus, an issue paper has somewhat less force than does a special condition.

To avoid questions as to the applicability of FAR 25.1309 to lightning protection, the FAA will shortly issue FAR 25.1315, which is similar to 1309 but pertains specifically to protection of avionics against the effects of lightning. It is the first such regulation to be issued by the FAA, and will obviate the need for special conditions.

This new regulation will define *critical functions* as those whose failure would contribute to or cause a condition which would prevent the continued safe flight and landing of the airplane. Critical functions must not be affected when exposed to lightning. Essential functions are those whose failure would contribute to or cause a condition which would significantly impact the safety of the aircraft or the ability of the flight crew to cope with adverse operating conditions. Essential functions must be protected to ensure that the

TABLE 1 U.S. Federal Aviation Regulations

	Vehicle Type and Regulations			
	Aircraft		Rotorcraft	
	General Aviation	Transport	Normal	Transport
Airframe	23.867	25.581	27.610	29.610
Fuel System	23.954	25.954	27.954	29.954
Other Systems	23.1309	25.1309	27.1309D	29.1309H
Avionics		25.1315		

function can be recovered in a timely manner after being exposed to lightning.

Neither FAR 25.1309 nor the forthcoming FAR 25.1315 define the lightning environment for design and certification purposes. This is found in FAA Advisory Circular 20-136 [3] which will be discussed in more detail later in this paper.

Lightning protection requirements for general aviation aircraft and general and transport category rotorcraft are included in Parts 23, 27 and 29, respectively, of the U.S. Federal Aviation Regulations [4], [5], [6]. The basic requirements are similar to those in Part 25, although application (and enforcement) of them to general aviation (Part 23) aircraft has not been as extensive. Lightning-protection regulations for rotorcraft are also similar to the transport aircraft (Part 25) requirements, and the recent introduction of FBW and FADEC systems to these vehicles has prompted renewed attention to the helicopter lightning-protection requirements.

Military aircraft and rotorcraft must either comply with FAA standards or Mil-Stds 1757A and 1795A, depending on their role. MIL-STD-1795A describes the protection requirements and the lightning environment, and MIL-STD-1757A presents verification tests methods. Both are the same as the FAA requirements for civil aircraft. MIL-STD-1795A is of interest because it extends protection beyond flight-critical/essential systems to include those systems whose failure could endanger mission success, or result in excessive maintenance costs, on an optional basis. These mission and maintenance factors, of course, are of equal concern to owners/operators of civil aircraft, but are not a part of the civil-airworthiness requirements.

Translation of these regulations into specific aircraft design goals is left to the manufacturer. However, in order to obtain certification, the manufacturer must verify that the aircraft and its systems are protected against catastrophic effects from lightning in accordance with these regulations.

4.0 STANDARDS

Beyond the regulations, the FAA has issued Advisory Circulars (AC) that provide more detailed information on how to achieve successful compliance with the FARs. The first lightning-related AC was 20-53 [7] that dealt with lightning protection of fuel systems. However, the FAA recognized that this did not cover other systems, so in 1972 the Society of Automotive Engineers Committee on Electromagnetic Compatibility was asked to form a subcommittee to develop improved aircraft lightning-protection standards. This committee was designated SAE AE-4L.

Over the years, the committee issued several reports which did much to define the threats posed by lightning and to recommend design practices and test methods required to ensure protection. Of

particular importance to electronic control systems is the SAE Committee Report AE4L-87-3, called the Orange Book, which was adopted by the FAA in 1990 as AC 20-136. The subject is "Protection of aircraft electrical/electronic systems against the indirect effects of lightning."

This AC defines the electrical characteristics of lightning for use in design and verification of protection against lightning indirect effects. This AC includes recent additions to the environment that are important to indirect-effects protection, including multiple strokes and multiple bursts which are described in [8]. In addition, AC 20-136 furnishes the engineer with procedural steps which can be followed to achieve and verify a successful design. These steps, as they apply to full-authority electronic control systems, are discussed in following sections of this paper.

5.0 INDIRECT EFFECTS

Since most parts of an FBW or FADEC system are installed inside an airframe, lightning indirect effects are of primary concern. These effects have been described fully elsewhere [9], [10], [11], [12] and include voltages and currents induced by changing magnetic fields and/or structural voltages in the interconnecting wiring associated with FBW and FADEC systems.

Of particular concern to digital systems is the potential for upset of data processing and control functions due to the effects of the multiple-stroke and burst environments. Whereas shielding and other protection approaches may control induced transients to non-damaging levels, the low-level transients that remain intermingle with them, resulting in erroneous commands. There will be as many transients as there are strokes or pulses in the "multiple" environments, and these may change or upset computer-generated words and commands. In one well-documented case, a single additional bit induced by a lightning strike to an Atlas-Centaur rocket launched by NASA from Cape Canaveral resulted in a hard-over guidance command and loss of the vehicle shortly after liftoff [13].

6.0 DIRECT EFFECTS

Electronic control systems may also be exposed to the direct attachment of the lightning channel to externally mounted sensors, such as air-data probes or actuator parts. Another concern is the puncture of non-conducting skins, resulting in direct lightning current flow into control system components. Direct effects may also be caused by lightning currents being transferred to the electronic systems via cables or power supplies shared with unrelated non-critical components such as antennae, probes or lights. It is the responsibility of the lightning-protection engineer to identify possible current paths of direct entry of lightning currents to the system.

7.0 STEPS IN DESIGN

The most successful lightning-protection design programs occur when the process is conducted in a logical series of steps. As outlined in AC 20-136, the steps are: a) Determine the lightning strike zones. b) Establish the external lightning environment for the zones. c) Establish the interior environment. d) Identify the aircraft flight-critical/essential systems and equipment. e) Establish Transient Control Levels (TCL) and Equipment Transient Design Levels (ETDL). f) Design protection. g) Verify protection. The balance of this paper describes steps a through f. Step g is the subject of a sequel paper [1].

7.1 a) DETERMINE LIGHTNING-STRIKE ZONES

There are five defined lightning-strike zones which are defined as follows: 1) Zone 1A: Initial attachment point with low possibility of lightning channel hang-on. 2) Zone 1B: Initial attachment point with high possibility of lightning channel hang-on. 3) Zone 2A: A swept-stroke zone with low possibility of lightning channel hang-on. 4) Zone 2B: A swept-stroke zone with high possibility of lightning channel hang-on. 5) Zone 3: Those portions of the aircraft that lie within or between the other zones, which may carry substantial amounts of electrical current by conduction between areas of direct or swept-stroke attachment points.

The location of the zones varies from one aircraft design to another, and depends upon aircraft geometry and operational factors. Therefore individual assessments must be made for each aircraft. Methods of determination are described in [14].

The lightning currents to be expected in each zone are shown in Table 2.

TABLE 2 Current Components Applicable in Various Zones

Zone	Current Waveforms					
	A	B	C	D	Multiple Burst	Multiple Stroke
1A	X	X			X	X
1B	X	X	X	X	X	X
2A		X		X	X	X
2B		X	X	X	X	X
3	X	X	X	X	X	X

Until recently, Zone 1A was identified as extending only 18 inches aft of the leading edge extremities such as engine inlets. However, in-flight experience and laboratory tests of scale models of aircraft have shown that Zone 1A may be extended up to 6 meters aft of leading edges. Thus, most surfaces of wing-mounted nacelles are located within Zone 1A and subject to the first return stroke, current component A. Trailing edges of engine nacelles and exhaust ducts are in Zone 1B, where all four components of the lightning environment are experienced. Flight-control surfaces have similar exposures, depending on their location on the aircraft.

It must be remembered that structures and components inside surfaces in most zones are in Zone 3 and are exposed to the effects of conducted currents. Figure 5 shows typical zones on a wing-

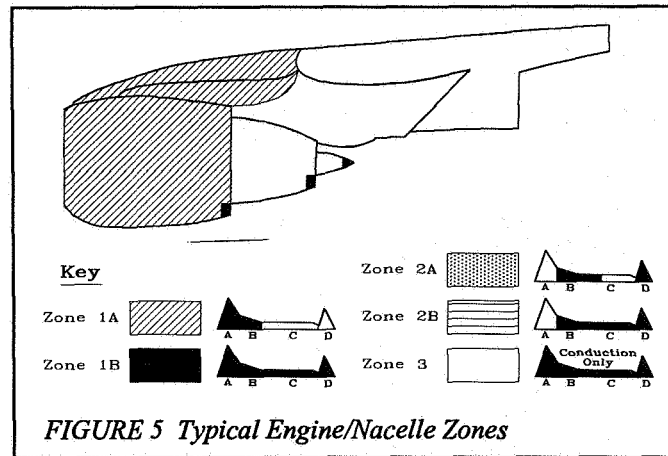

FIGURE 5 Typical Engine/Nacelle Zones

mounted engine nacelle.

Once zones have been established for a particular aircraft design, they should be documented on a drawing of the vehicle with boundaries identified by appropriate station numbers or other notation. It is appropriate for the applicant to review and obtain FAA concurrence for the zone drawings since these determine the specific components of the lightning environment that the system must withstand.

Of essential concern to the aircraft designer is the identification of the various zones and surface materials through which the flight-critical electronic control systems pass. This will aid in determining the direct and indirect effects to be expected and the protection methods required, as will be discussed later in this paper.

7.2 b) ESTABLISHING THE EXTERNAL LIGHTNING ENVIRONMENT

The results of recent research into characteristics of lightning encountered by aircraft has focused attention beyond the effects of cloud-to-earth lightning, to include the additional characteristics of intracloud and cloud-to-cloud lightning strikes, especially as they may affect electronic systems. Whereas the amplitude and action integrals of the currents in these strikes are usually less than those associated with cloud-to-earth flashes, other aspects, such as peak rates of change of current and multiplicity of pulses, are of particular concern.

The most significant of these results is the multiple-burst lightning environment, composed of a large number of comparatively low amplitude pulses, characterized by high rates of change (up to 2×10^{11} a/s) and short duration (between 1 and 10 microseconds), and occurring randomly over the lifetime of the lightning flash.

Multiple-burst phenomenon is now added to the cloud-to-earth lightning environment which includes the four basic current components and the multiple-stroke environment based on components A and D/2, as follows:

Component A: Initial High Peak Current Component B: Intermediate Current Component C: Continuing Current Component D: Restrike Current Multiple Stroke (Component A, followed by 23 Components D/2)

The multiple-burst environment, or Component H, as described in AC 20-136 Appendix III, has a peak current of 10 kA and a peak rate of rise of 2×10^{11} a/s.

For evaluation of the indirect effects of lightning to sensitive

aircraft electronics, it is necessary to consider both the multiple-stroke and multiple-burst environments, in addition to the basic indirect effects arising from Component A. This is because the succession of D/2 strokes or H pulses may induce corresponding pulses in data transfer circuits, for example, causing upset or cumulative damage to sensitive systems or devices, as noted previously.

7.3 c) ESTABLISH THE INTERNAL ENVIRONMENT

A lightning strike injects a wide assortment of electric currents into the airframe, some of which reach hundreds of thousands of amperes. These currents diffuse throughout conducting structures and are accompanied by changing electromagnetic fields, which can also penetrate to the interior of the aircraft.

The fields and structural IR voltages constitute the portion of the internal lightning environment which causes the voltages and currents on interconnecting wiring that in turn appear at sensitive equipment interfaces. In some cases, electromagnetic fields within the aircraft may penetrate equipment enclosures and compromise system operation.

The mechanisms whereby lightning currents and magnetic fields interact with electrical and electronic systems are illustrated in Figure 6.

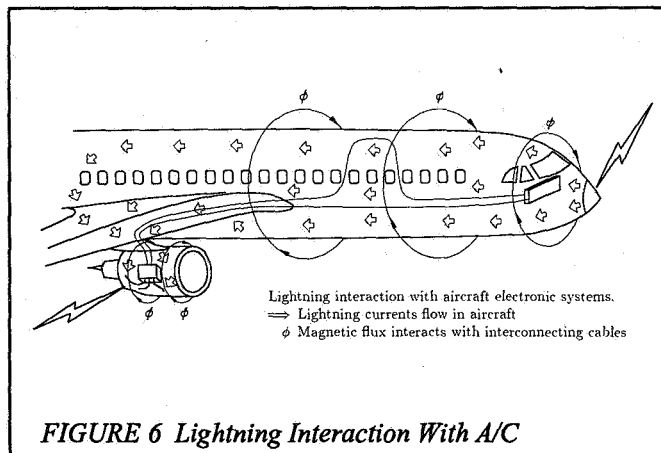

FIGURE 6 Lightning Interaction With A/C

The passage of current between fuselage and engine nacelle creates a potential difference (voltage) between the flight deck and engine-mounted computer. In an aircraft constructed of conventional aluminum, resistance is primarily in the fuselage/wing, wing/pylon and pylon/engine joints. Whereas these resistances are small, lightning-stroke currents of 200 kA can produce IR voltages of several hundred volts. These structural IR voltages may drive currents into interconnecting wires between electronic components in the cockpit and nacelle.

The lightning currents in the airframe are accompanied by changing magnetic fields which increase and decrease in amplitude along with the lightning current. A portion of these fields may penetrate through apertures in the fuselage, wing, pylon and nacelle and induce voltages in unshielded interconnected wiring or currents in the shields of shielded cables.

The multiple-burst environment is not necessarily a salient factor in a damage assessment, but can be the primary factor in a system upset. Since major electrical/electronic systems are composed of

components that are distributed throughout the aircraft, verification of compliance relative to functional upset involves consideration of the overall lightning environment to which the system is exposed. Functional upset can be a particularly important issue for digital processor-based systems in modern aircraft.

Determining the interior lightning environment is generally considered the responsibility of the airframe designer. However, sophisticated electronic control systems and equipment now being employed in aircraft, and the use of composite skins, necessitate a closer working relationship between the airframe designer and the equipment designer to fulfill the design goals of adequate lightning protection and aircraft performance and economy.

Two methods are generally accepted in determining the internal environment: Numerical analysis, as described in detail in [15] and experimental analysis [16]. Numerical analysis methods, which are still in their relative infancy, are often validated by comparison with test data on simple airframes and/or wiring installations, and then extended to address more complex installations.

The difficulty here is that in the extension, complex installations may introduce factors that affect computed results by at least one order of magnitude; yet these factors are not quantified and therefore neglected. Figure 7 shows the type of situation that can be analyzed, and a real-life installation this approach is sometimes intended to represent.

Electromagnetic interference, from such sources as radio trans-

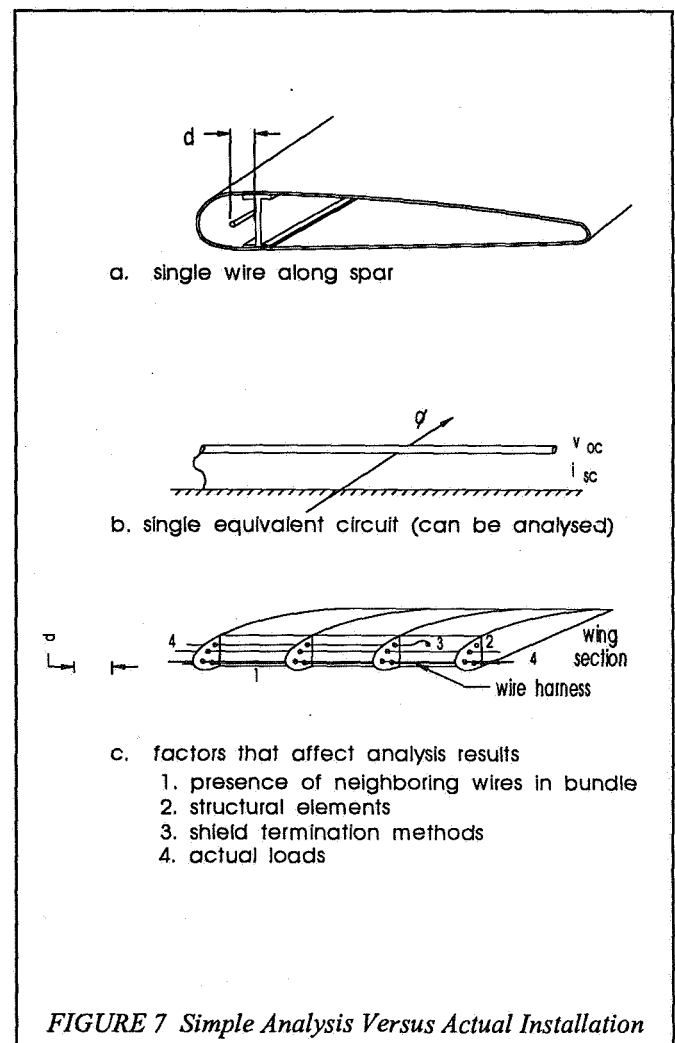

FIGURE 7 Simple Analysis Versus Actual Installation

mitters or radar systems, presents a different coupling mode than that of lightning. EMI, though present in the external environment, with the possibility of coupling with the internal environment, requires no special protection methods. An aircraft employing proper lightning protection methods will exclude adverse EMI effects.

7.4 d) IDENTIFY THE FLIGHT-CRITICAL/ESSENTIAL SYSTEMS AND EQUIPMENT

Flight-critical and essential systems and equipment include, but are not limited to:

- Engine parameters
- Wing anti-ice system
- Aircraft power
- Fuel-flow electrical
- Flight instruments
- Warning lights power
- Stall barrier
- Audible tone generator
- Communication system(s)
- Engine fire determination
- Navigation capabilities

In addition to identifying systems and equipment, a major consideration for the designer is to determine their locations and the routing of wiring within the aircraft and review the location of interfacing equipment which is not critical or essential but may provide an indirect (back door) for substantial lightning-induced transients. These transients may propagate from externally mounted probes or devices on the aircraft or be routed from regions with intense magnetic fields.

Complex integrated avionic systems many times display a variety of functions of which some may be critical/essential, while other functions are only supplementary and, if lost, will not significantly degrade the level of safety. Failure or loss of certain noncritical and non-essential information may be acceptable as long as the critical/essential functions are maintained. The identification of critical/essential functions should be the determining factor for what systems or portions of a system must remain operable or no affected by the lightning event.

The determination of flight-critical/essential functions and equipment should be a formalized policy. Generally, it is best to have inputs into this list from not only system designers but from other support groups such as reliability (failure-mode analysis) groups and flight-test operations. This becomes very important since flight test may be required to demonstrate the ability to safely operate the aircraft from the critical/essential equipment list. Thus the critical and essential systems (or equipment) listing becomes a key certification issue which should be well conceived and agreed to by program management.

7.5 e) ESTABLISH TCL AND ETDL

The Transient Control Level philosophy was originally inspired by the Basic Insulation Level (BIL), or transient coordination philosophy, used successfully in the electric power field for many years. The TCL approach follows the BIL approach to transient coordination in that targets or specifications relative to transients should be assigned both to those who design electronic equipment and to those who design wiring to interconnect such equipment, rather than allowing things to develop by chance. The TCL philosophy is illustrated in Figure 8.

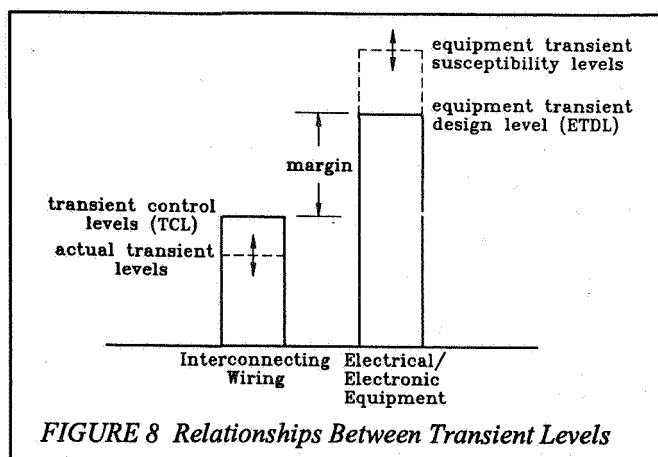

FIGURE 8 Relationships Between Transient Levels

It encompasses the following:

- **Actual Transient Level:** Ensuring that the actual transient level produced by lightning or any other source of transient will be less than that associated with the transient control level number assigned to the cable designer. The cable designer's job is to analyze the electromagnetic threat that lightning would present and to use whatever techniques of circuit routing or shielding are necessary to ensure that the actual transients produced by lightning do not exceed the values specified for that particular type of circuit.

- **Equipment Transient Design Level:** The ETDL establishes the levels of transients that must be tolerated by the equipment within a system. This tolerance can be achieved, of course, by inherent hardness or tolerance of the electronic devices within the equipment or by installation of surge-protection devices (SPDs) at the equipment terminals. The purpose of these SPDs is to limit incoming transients to levels that can be tolerated by equipment and components.

Prediction of the actual transient levels during the system design phase is difficult because of the large number of individual wires and installation configurations that abound in any complex system. Therefore, there will always be a possibility of some wires or circuits experiencing higher transients than those which have been predicted by analysis during the design phase or even those which have been measured during tests of full vehicles. In the latter case, it is never practical to measure transients in every single wire due to time constraints.

This topic of margins is very important, and one which the regulatory authorities have not formulated definite policies on. That is, the amount of the margin is uncertain in some cases. In general, the greater the degree of confidence that one has in the actual transient levels, the smaller the margin can be. Conversely, if actual transient levels, and therefore transient control levels, have been established purely by estimation or analysis techniques, or by similarity with other designs and not by test, then the authorities require use of a larger margin.

Margins as small as 50 percent and as large as 10-1 have been required in the past. Recently, several advanced flight- and engine-control systems have been certified with a margin of 2-1 when the actual transient levels in interconnecting wires have been measured and verified by aircraft tests and when the capability of the equipment to tolerate the transient design levels have also been verified by test.

Further discussion of recommended test techniques will appear in

Selection of the most appropriate method is challenging since it depends on the ultimate use of the data and the state of development of the aircraft. A simulation technique that imposes all features of the lightning in a proper time sequence is desirable but this may not be effective for subsystems or for providing design data. It is especially important that the simulation technique provide data on the system, subsystem or component equipment on line replaceable unit (LRU) responses that can be extrapolated to the values that occur when the aircraft is exposed to the real lightning environment.

Transient design and control levels are best defined in terms of the waveshapes and amplitudes of induced voltage and current transients that appear at interfaces between equipment and interconnecting wires. Specifically, this means the transients that appear on equipment connector pins. In most cases, lightning strikes will induce the maximum levels of transients between interconnecting wires and airframe ground. Therefore, the maximum induced transients will nearly always appear between connector pins and case ground. Thus it is usually preferable to design the equipment transient design levels as the levels of transients that must be withstood by the equipment between incoming connector pins and equipment case ground.

This is often referred to as a *pin specification*. Of course, in any complex system there will be many wires and pins interfacing with each piece of equipment. These wires will extend to varied locations within the aircraft and will experience varying amplitudes and waveshapes of transients. In addition, these circuits may themselves operate at a different or varied system voltage levels. For example, some incoming wires bring 115 V or 28V aircraft power to the equipment. Others, however, only transmit very small signal voltages whose amplitudes do not exceed 1V or 5V. Thus it often makes sense to establish more than one transient design level for a single piece of equipment with the individual levels being related to either the function of the incoming circuit and connector pin or the routing of that circuit through the aircraft.

Thus, for example, for a typical flight-control computer, one transient design level could be established for incoming 115V AC power circuits, a second level might be established for incoming 28V DC aircraft power circuits, and a third equipment transient design level could be established for incoming or outgoing signal and control circuits.

Frequently, each of these functions passes through the same multi-pin connector. In this example, a single connector can have pins which must withstand differing equipment transient design levels.

But in all cases, the levels would be defined as follows:

- A waveshape
- A peak voltage
- A peak current

The voltage referred to above is the maximum voltage which would be expected to appear at the open-circuit terminals of the interfacing wire with no load. This is referred to as the open-circuit voltage as shown in Figure 9 (a). The current specification is the maximum current expected to be induced in the same interconnecting circuit(s) when that circuit is shorted to ground at the equipment as in Figure 9 (b). Of course, in most cases, the load within the equipment is a finite impedance, so that neither the open-circuit voltage nor the short-circuit current will appear at the equipment in an actual lightning strike event as shown in Figure 9 (c). But if the transient design level specification is described in this manner, then the proper amplitude of transient will appear at the equipment when

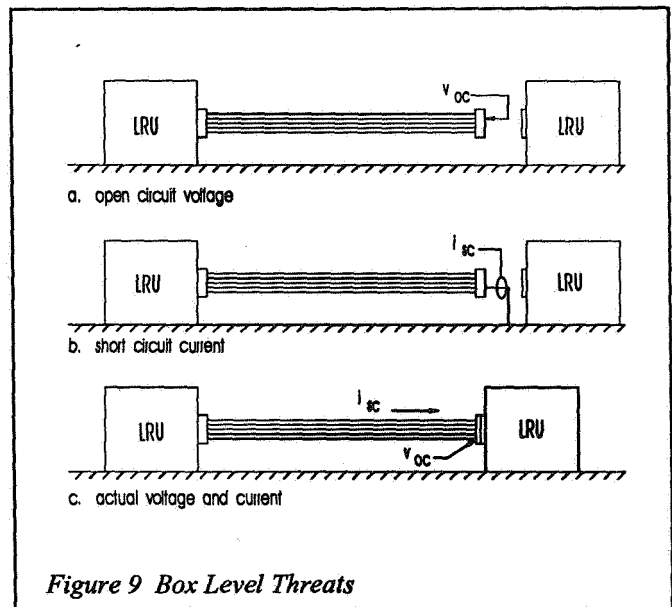

Figure 9 Box Level Threats

the equipment is tested with a test set that can also produce either the open-circuit voltage or the short-circuit current.

7.5.1 CONSIDERATIONS IN ETDL SELECTION

The importance of ETDLs applicable to the equipment connector pins is that it establishes the transient levels which equipment components must withstand without burnout. This is the very basic and most important part of the ETDL specification for flight critical and essential equipment. Compliance with pin specifications will require proper selection of equipment components and/or the application of surge-suppression devices. A further discussion of protection devices is contained in Design Protection section of this paper.

Verification of compliance with pin ETDL requirements usually means the application of a pin-injection test as described in [1]. In this test, transients are applied to pins individually. This means that the equipment cannot be interconnected with other equipment on the test bench. A pin specification and pin-injection test are not capable of evaluating the synergistic effects that may occur due to the simultaneous application of transients on all incoming circuits and at all connectors within the system. It is therefore usually necessary to specify a second type of ETDL which is applicable to a fully interconnected and operating system.

This second ETDL is often a bulk cable current specification which defines the waveshape and amplitude of the total current expected to be induced in the cables which interconnect the various components of the system, such as those which connect the flight-control computer to secondary actuators in a flight-control system. For this purpose, a bulk cable current waveshape, such as waveform 1 or 5, as shown in AC 20-136 is often selected together with a peak amplitude. Amplitudes of bulk cable currents induced on intra-engine cables of a full-authority digital engine control system would range in the thousands of amperes, whereas the amplitudes of bulk cable currents circulating in cables installed within an aluminum fuselage might be less than 100 amperes.

Bulk cable current specifications are most appropriate for cables in which the bundle of wires is enclosed within an overall shield or in which most of the circuits are enclosed within individual shields, and these shields are grounded to equipment cases at each end. In this case, of course, the lightning magnetic fields induce voltages and

currents in the loop between the cable shields and the airframe. In some cases, cables may not simply extend between two pieces of equipment but may branch and extend from one piece of equipment such as a computer to several remote items such as actuators and sensors. In these cases, care must be given to selection of realistic current levels. For example, the bulk cable current at the computer end of such a cable would be the sum of the bulk cable currents entering each of the accessories which are fed from branches of this same cable.

The bulk cable current specification is viewed as a system specification, both from a component-damage and system-upset perspective. Cable shields, connectors, equipment cases and components within the equipment must, of course, withstand the effects of the specified currents flowing on the cable shields. Currents on shields will, of course, produce transient voltages in conductors and at equipment interfaces within those shields. These transients will be lower in amplitude than they would be were the shields not present or ungrounded. Nonetheless, these transients still exist and in some cases may reach damaging levels. Also, induced transients which do not meet damaging levels may still be capable of upsetting digital-processing circuits, especially when it is recalled that there will be more than one transient produced by an individual lightning flash. The bulk cable current specification therefore enables realistic induced transients to be induced simultaneously in all cables and conductors within a system. And if for verification purposes this ETDL is applied in a multiple-stroke or multiple-burst mode, it is indeed possible to evaluate system upset possibilities and/or verify that the system will not upset when exposed to the specified ETDL.

For interconnecting cables which are not shielded it may not be appropriate to specify a bulk cable current or at least a bulk cable current by itself. In these cases, the cable ETDL may be specified as both an open-circuit voltage and a short-circuit current. In this case, the open-circuit voltage is the voltage that would appear between the ends of all interconnecting wires and airframe ground when disconnected from the equipment. The short-circuit current factor is the total current that would flow from all connectors to airframe ground when these connectors are shorted to airframe ground at the equipment. Thus in this latter case the short-circuit current factor can be viewed as the sum of the short-circuit currents in all the individual wires within the cable bundle.

7.5.2 OTHER ASPECTS OF ETDL SPECIFICATIONS

It must be remembered that whereas ETDLs are defined as a single waveform, they do appear as multiple transients because of the

fact that lightning flashes inject more than one stroke or pulse of current through the airframe with each stroke or current pulse producing a corresponding transients. This aspect of the lightning environment has been defined as the multiple-stroke and multiple-burst environment in AC 20-136. Therefore whenever at ETDL is defined, it must be viewed as a multiple-transient threat as illustrated in Figure 10.

The first of these pulses is at the specified ETDL level and the second through the 24th of which are either at one-half or one-fourth of the specified ETDL depending upon the coupling mode. Subsequent transients which are predominantly due to changing magnetic fields would be one-half of the original ETDL. Transients which are predominantly due to structural IR effects are one-fourth of the amplitude of the original ETDL.

Thus the equipment components must be designed and verified to withstand the first ETDL transient but the subsequent 23 transients at reduced levels. Test and analysis methods for verification and compliance with this multiple-stroke specification are discussed more fully in [1].

Damaging effects of the subsequent stroke components of the multiple-stroke environment are significant and do need to be accounted for in equipment design and in the selection of surge-protection devices which will be discussed in the following section.

The damaging effects of multiple-burst transients are usually negligible and need not be considered in selection of circuit elements or SPDs. However, the multiple-burst transients are important from an upset standpoint.

7.5.3 PITFALLS IN ETDL SELECTION

One method of defining ETDL for system equipment has been to define the characteristics of a transient which is applied between an equipment case and a test bench ground when that case has been elevated from ground. In this case, a short cable(s) is attached to the equipment and grounded through simulated loads a short distance away from the equipment. Verification is achieved by applying the specified transient between the equipment case and test bench ground. Unfortunately, one cannot be certain of the value of the levels of actual transients applied to specific pins or electronic devices within the equipment because in most cases there exist one or more ground wires or grounded shields between the equipment and the simulated loads a short distance away.

These wires inevitably accept most of the transient energy and leave the remaining conductors relatively unexposed. Unfortunately, the method just described has been formalized in several industry specification and test requirements, including RTCA DO-160, [18] and many equipment vendors have received the misleading impression that compliance with such a specification indicates that their equipment can indeed tolerate an ETDL at its interface(s) as described earlier in this section.

Nothing could be further from the truth. Also, unfortunately, potential users of such equipment have been led astray and given the false assumption that equipment thus qualified is capable of tolerating actual transient levels that appear between individual wires and airframe ground. Fortunately, industry standards-writing groups are taking a second look at these methods and clarifying the results obtained from them as compared with the pin specification.

Flow charts demonstrating logical progression of steps toward integration of design at the airframe and component levels are shown in Figure 11.

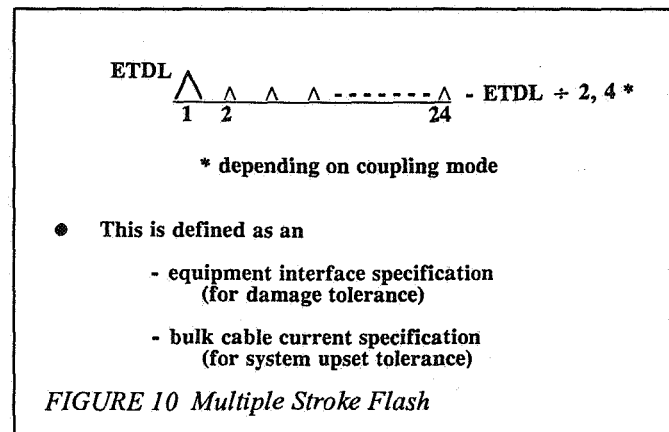

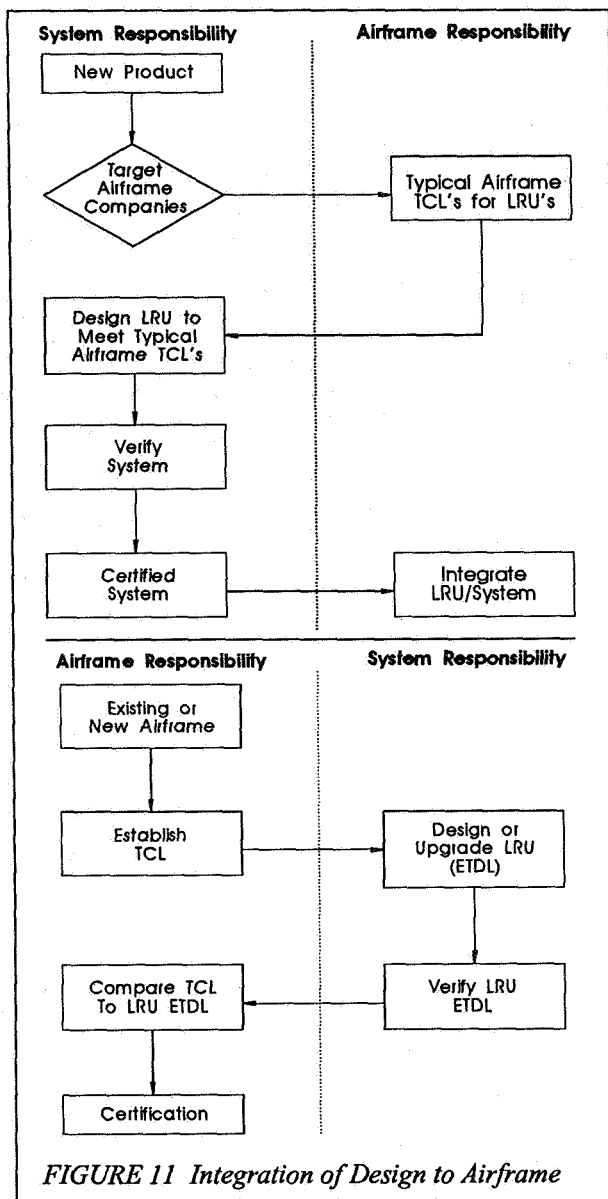

FIGURE 11 Integration of Design to Airframe

7.6 f) DESIGN PROTECTION

To minimize the possibility of upset or damage, the ETDL should be higher than the TCL allowed to appear at equipment interfaces. In cases where the TCL plus the defined margin exceed the transient design level, additional protection must be provided. The optimum protection design is based on many factors, including level of required and provided protection, cost, weight, impact on production schedule, impact on vehicle performance, maintenance, reliability and ability to withstand other natural and man-made environments.

In general, the objective of the protection design is to:

- Reduce the level of the transient that reaches the vulnerable electric or electronic circuit.
- Decrease vulnerability of the circuits by increasing their damage and upset thresholds.
- Increase the design margin by combining elements of the above.

Design techniques commonly used to reduce transient levels include shielding, cable routing, circuit wiring type selection, terminal protection and dielectric isolation. Techniques that decrease

circuit vulnerability include circuit designs with high damage levels, high-level logic, and use of hardware and software techniques to increase circuit upset tolerance.

In order to make an electronic system immune to the effects of lightning, it is almost always necessary to make judicious use of shielding on interconnecting wiring and to provide proper grounding of these shields.

Of the different types of shields, the solid shield inherently provides better shielding than does a braided shield, and a spiral-wrapped shield can be far inferior to a braided shield in performance.

In severe environments, braided shields using two overlapping courses of braid may give shielding performance approaching that of a solid-walled shield.

Conduits should not be relied upon for protection against indirect effects since they may or may not provide electromagnetic shielding. Only if the conduit is electrically connected to the aircraft structure will it be able to carry current, and thus provide shielding for the conductors within.

The presence of a shield grounded at only one end will not significantly affect the magnitude of the voltage induced by changing magnetic fields, although a shield may protect against changing electric fields. While a shield may keep the voltage at the grounded end low, it will allow the common mode voltage on the signal conductors to be high at the unshielded end.

Shielding against magnetic fields requires the shield to be grounded at both ends, in order that it may carry a circulating current. It is the circulating current that cancels the magnetic fields that produce common mode voltages.

There is some virtue in staggering spacing between multiple-ground points on a cable shield, since it is theoretically possible that uniform grounding can lead to troublesome standing waves if the shield is illuminated by a sustained frequency interference source. Also, the cable may be exposed to a significant amount of magnetic field over only a small portion of its total length. If the shield is multiple-grounded, the circulating currents will tend to flow along only one portion of the cable, whereas if it is grounded at only the two ends, current is constrained to flow the entire length of the cable.

The requirement that a shield intended for protection against lightning effects must be grounded at both ends raises the perennial controversy about single-point versus multi-point grounding of circuits. For many reasons, mostly legitimate, low-level circuits need to be shielded against low-frequency interference. Most commonly, and usually legitimately, the shields intended for such low-frequency interference protection are grounded at only one end.

A fundamental concept, often overlooked is that the physical length of such shields must be short compared to the wavelength of the interfering signals. Lightning-produced interference, however, is usually broad-band and includes significant amounts of energy at quite high frequencies - frequencies higher than those the typical low-frequency shields are intended to handle. This conflict is usually too great for both sets of requirements to be met by only one shield system.

Most commonly, both sets of requirements can be met only by having one shield system to protect against low-frequency interference and a second to protect against lightning-generated interference. The lightning shield can usually consist of an overall braided shield on a group of conductors, with this overall shield being grounded to the aircraft structure at least at the ends. Within the overall shield may be placed whatever types of circuits are needed. Such an overall shield is shown in Figure 12. Other types of

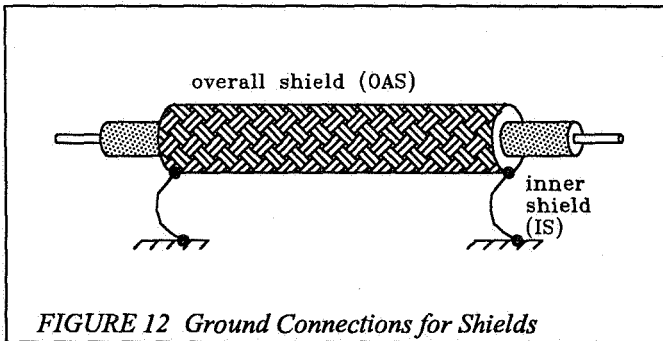

FIGURE 12 Ground Connections for Shields

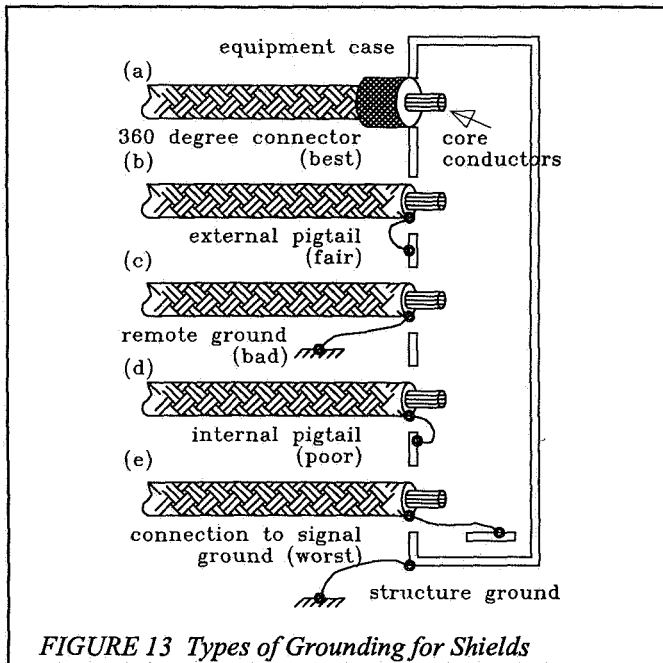

FIGURE 13 Types of Grounding for Shields

grounding for shields are shown in Figure 13.

An in-depth treatment of equipment location and associated wiring can be found in [17].

Because of other constraints, the designer may not have much choice in the location of electronic equipment. But it is often possible to make improvements in the resistance to indirect effects by locating equipment in regions of the aircraft where the electromagnetic fields produced by lightning current are the lowest, and by avoiding placement in the region where fields are the highest. For example, since the most important type of coupling from the outside electromagnetic environment to the inside of the aircraft is through apertures, it follows that equipment should be located as far from major apertures as possible.

One main goal is to locate electronic equipment toward the center of the aircraft structure, since the electromagnetic fields tend to cancel toward the center of any structure. Other goals include locating equipment away from the outer skin of the aircraft, particularly the nose; and, if possible, electronic equipment should be located in shielded compartments.

Of particular importance to aircraft using large amounts of composite materials is the type of shelf upon which electronic equipment is located. Shelves are called upon to provide ground planes or reference surfaces for electronic equipment, and thus it is essential that they be highly conductive and well-bonded to the aircraft structure.

Some basic principles apply:

- The closer a conductor is placed to a metallic ground plane, the less is the flux that can pass between that conductor and the ground plane.

- Magnetic fields are concentrated around protruding structural members and diverge in inside corners. Hence, conductors located atop protruding members will intercept more magnetic flux than conductors placed in corners, where the field intensity is weaker.

- Fields will be weaker on the interior of a U-shaped member than they will be on the edges of that member.

- Fields will be lowest inside a closed member.

Circuit protection devices can sometimes be used to limit the amount of electrical energy that a wire can couple into a piece of electronic equipment. While one can seldom eliminate interference through the use of circuit protection devices, when judiciously used, they can virtually eliminate physical damage to electronic devices. Protective devices should be incorporated into a piece of equipment at the time it is built, not added after trouble has been experienced.

Circuit protection devices, described in [19] include:

- Switching devices
- Non-linear devices
- Circuit interrupters
- Spark gaps
- Metal oxide varistors
- Zener-type diodes
- Reverse-biased diodes

Frequently a spark gap and a MOV, or an MOV and a surge-protecting diode, are used together to provide added protection. The higher energy device is connected close to the point where the surge may enter the system, and the lower energy device is connected close to the more sensitive components. The principle is that the high-energy device provides the primary protection and diverts the major portion of the surge energy, while the lower-energy device provides protection for the residual transients.

Protective devices cannot be operated directly in parallel since the device with the lowest clamping voltage would carry all the surge current. Impedance between the two is needed to limit the surge current in the lower energy device and allow voltage to develop that initiates conduction in the high-energy device. Best protection is obtained if the two surge protectors are physically separated, where possible.

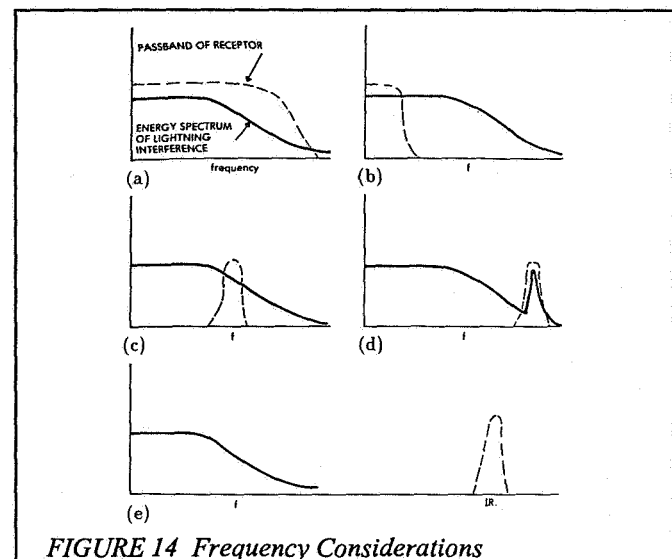

FIGURE 14 Frequency Considerations

One of the most important considerations in the control of lightning-related interference through proper circuit design lies in the fundamental observation that a device with a broad bandwidth can intercept more noise energy than can a narrow bandwidth device. Some of the considerations that derive from this observation are contained in Figure 14.

The noise produced by lightning has a broad frequency spectrum. Equipment is damaged or caused to malfunction in accordance with the total amount of energy intercepted. In a lightning flash there may be plenty of energy left in the megahertz and multimegahertz region to cause interference. The energy that is available for damage or interference may well be concentrated in certain frequency bands by the characteristic response of the aircraft or the wiring within the aircraft.

The studies of types of interference produced in aircraft by the flow of lightning current have shown that the lightning energy excites oscillatory frequencies on aircraft wiring, particularly if the wiring is based on the single-point grounding concept. If at all possible, the pass bands of electronic equipment should not include these frequencies, as does the hypothetical pass band shown in Figure 14 (d). Higher or lower pass bands would inherently be better than the one shown. As an extreme example, shown in Figure 14 (e) fiber optic signal transmission operating in the infrared region avoids the frequency spectrum associated with lightning-generated interference almost completely.

Once the ETDLs have been established, it is important to look at the protection design of individual equipment from a system standpoint when possible, and some intelligent decisions can be made.

If a system is protected on an independent basis where SPDs are installed at each end of a circuit, there is the potential for burning out

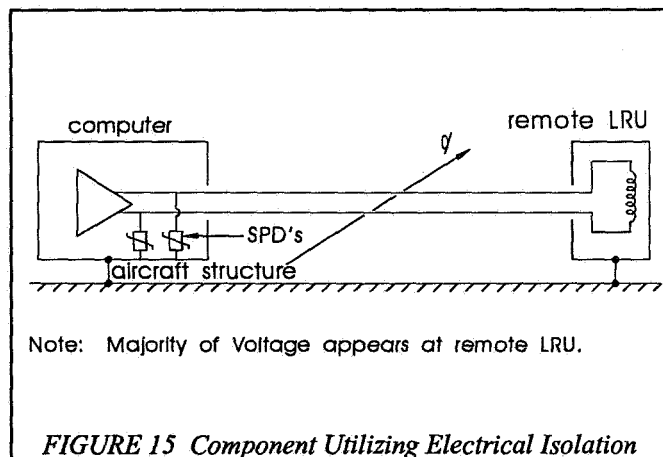

FIGURE 15 Component Utilizing Electrical Isolation

the SPDs at both ends of the circuit. Therefore, placing SPDs at interfaces of all LRUs within a system is not always a good idea. It adds weight and cost to the equipment. Instead, there are several alternatives which make sense from a system design standpoint. One is applying an SPD at one end of a circuit and utilizing electrical insulation between incoming elements and case ground at the other end, as illustrated in Figure 15.

Because of that insulation, no current flows. Because no current flows, no current flows through SPDs at the computer end and they are not stressed. The SPDs are there in the rare event that a transient might appear there, but they are not stressed by short-circuit currents because the remote ends of the circuit conductors are insulated from ground.

A variation consists of SPDs used at the computer as before.

When complete insulation is not possible in the remote LRUs, it is possible to install series impedance at the interfaces of the remote LRU. Thus, in this particular case, some current will flow in the circuit, but the current will be limited by the series resistance to a level which is safe enough so that SPDs in the computer do not burn out.

When either of these two approaches is employed for protection design, it is essential that both LRUs be assigned the same ETDL and that both be verified by test, specifically by the pin-injection test described earlier and which will be discussed further in [1]. When the pin-injection test is applied to the computer interface, the open-circuit voltage of the test set will be clamped to the rated clamping level of the SPDs in the computer and current will flow through them. This current will be limited by the short-circuit current factor in the ETDL specification and, of course, the SPDs must be able to tolerate this amount of short-circuit current to pass the test. At the remote LRU, the same test set is applied to the connector pins of the same circuit. In this case, the entire test set voltage which is the ETDL open-circuit voltage level, will appear between incoming pins and case ground because there are no SPDs and no other elements or connections between incoming circuits and case ground. Thus the insulation between LRU circuit elements and case ground must be capable of tolerating the full ETDL voltage level.

A major challenge facing FADEC and FBW system designers concerns the performance of system software in the presence of indirect lightning effects. [20], [21], [22], [23]. Circuits should be designed to tolerate momentary logic upsets and to return to normal operation after a transient. Designers should avoid circuits that latch up in an abnormal mode, and use logic with high transitional levels wherever possible.

In a practical sense, upset is very difficult to prevent by shielding because the signal levels must be reduced to below the level of the logic voltage (usually a very low signal of 5 to 12V). Protection devices cannot be used because the devices, if they are set below the logic level, would effectively upset the logic. Upset hardening is often handled by software that allows the upset to occur but ensures that it will not be catastrophic to the aircraft or its operation. Optical isolation equipment is effective in reducing upset.

Following are a few examples of the software techniques that should be considered to minimize upset:

- Program execution from random access memory (RAM) is undesirable.
- Exit from temporary loops must be guaranteed.
- Return from all possible interrupts is mandatory.
- Use system cross-checking and process redundancy that involves multiple execution of a process and comparison of results.
- Use checkpoint rollback where critical information is periodically and routinely recorded on a backup or redundant-storage medium.
- Use plausibility checks that verify that information being processed or the result of computation fall within realistic bounds.
- Use timeouts for certain operations to occur.

8.0 CONCLUSION

This paper has discussed the first six steps in the lightning protection certification process. The sequel paper, "Certification of Lightning Protection for a Full-Authority Digital Engine Control," discusses the verification process in detail.

REFERENCES

- 1) M. Dargi, E. Rupke, K. Wiles, "Certification of Lightning Protection for a Full-Authority Digital Engine Control," International Aerospace and Ground Conference on Lightning and Static Electricity, 16-19 April, 1991.
- 2) U.S. Federal Aviation Regulations, Airworthiness Standards: Transport Category Airplanes, June 1974
- 3) "Protection of Aircraft Electrical/Electronic Systems Against the Indirect Effects of Lightning," FAA AC 20-136, 5 March, 1990.
- 4) U.S. Federal Aviation Regulations, Airworthiness Standards: Normal, Utility and Acrobatic Category Airplanes, December 1974.
- 5) U.S. Federal Aviation Regulations, Airworthiness Standards: Normal Category Rotorcraft, 1974.
- 6) U.S. Federal Aviation Regulations, Airworthiness Standards: Transport Category Rotorcraft, 1974.
- 7) "Protection of Airplane Fuel Systems Against Fuel Vapor Ignition Due to Lightning," FAA AC 20-53A, Federal Aviation Administration, Washington, D.C., 12 April, 1985.
- 8) F.A. Fisher, J.A. Plumer, R.A. Perala, "Lightning Protection of Aircraft," Lightning Technologies, Inc., 1990; Chapter 5.
- 9) Fisher et.al., Chapter 4.
- 10) Fisher et.al., Chapter 8.
- 11) Fisher et.al., Chapter 11.
- 12) Fisher et.al., Chapter 14.
- 13) NASA Report of Atlas-Centaur-67 FLTSATCOM F-6 Investigation Board, July 15, 1987.
- 14) Fisher et.al., Chapter 5.
- 15) Fisher et.al., Chapter 10.
- 16) Fisher et.al., Chapter 13.
- 17) Fisher et.al., Chapter 16.
- 18) "Environmental Conditions and Test Procedures for Airborne Equipment, Radio Technical Commission for Aeronautics.
- 19) Fisher et.al., Chapter 17.
- 20) "Damage and Voltage Breakdown Threshold Data Base Improvement Test Report," document D-180-28467-1, Boeing Aerospace Co., Seattle, Wash., 1984.
- 21) G.W. Masson, "Upset Experimentation in Computer-Based System," Eighth International Aerospace and Ground Conference on Lightning and Static Electricity, 21-23 June, 1983.
- 22) R.A. Perala, T. Rudolph, F. Erikson, "Electromagnetic Interaction of Lightning with Aircraft," IEEE Transactions on Electromagnetic Compatibility, Volume EMC-24, Number 2, May 1982.
- 23) G.M. Masson, "Intermittent/Transient Faults in Digital Computers," Compendium of Lightning Effects on Future Aircraft Electronic Systems, DOT/FAA/CT-82/30, February 1982.