

N92-11110**NUCLEAR LIGHT BULB**

Tom Latham
United Technologies Research Center

The nuclear light bulb engine is a closed cycle gas core concept. United Technologies made a policy decision in the early days of gas core reactor development that we were not to work on any concept that didn't have the potential of complete containment of the nuclear fuel.

During that era we did support NASA-Lewis with contracted open cycle gas core flow test work and shared a great deal of technical information from the nuclear light bulb program.

The nuclear light bulb concept provides containment by keeping the nuclear fuel fluid mechanically suspended in a cylindrical geometry. Thermal heat passes through an internally cooled, fused-silica, transparent wall and heats hydrogen propellant (Figure 1). The seeded hydrogen propellant absorbs radiant energy and is expanded through a nozzle.

Internal moderation was used in the configuration which resulted in a reduced critical density requirement. This result was supported by criticality experiments. If, in addition, we used U233 nuclear fuel instead of U235, we gained about a two-thirds reduction in overall fuel loading.

A reference engine was designed that had seven cells and was sized to fit in what was then predicted to be the shuttle bay mass and volume limitations (Figure 2).

The pressure vessel, the hydrogen cooling pumps, the secondary cooling system, fuel handling systems and thrust nozzles fit into a bay that measures about seven meters long by four meters in diameter. The total engine weight is around 70,000 pounds (Figure 3), the engine power is around 4,600 megawatts, and the thrust-to-weight ratio is 1.3.

These numbers were chosen relatively carefully. We chose these operating levels so that we did not have to use space radiators in the system to remove excess heat from the moderator or pressure vessel. If you go much beyond this performance, you do have to start using space radiators to remove extra heat.

If you increase specific impulse to 2,500 to 3,000 seconds, you have thermal radiation dominated heating of the nozzle throat. There were studies done of nozzle throat cooling schemes to remove the radiant heat. That's an important technical question to tackle.

A VOICE: Radiation from the gas?

PRECEDING PAGE BLANK NOT FILMED

MR. LATHAM: Yes. The gas and the seed that is in it. The hydrogen flow through the nozzle is optically thick because it has tiny tungsten seed particles in it.

Elements of the nuclear light bulb program included closed loop critical assembly tests done at Los Alamos with UF_6 confined by argon buffer gas (Figure 4).

We also showed that transparent fused-silica, when subjected to a high intensity ionizing dose rates, exhibit a radiation damage annealing effect that restores transparency.

We did some work that showed that the fuel region could be seeded with constituents that would block UV radiation from the uranium plasma. That reduces radiation energy absorption in the fused-silica wall at wavelengths below the UV cutoff. That has to be verified experimentally.

Argon seeded with sub-micron tungsten particles to simulate seeded propellant was heated by thermal radiation from a high power dc-arc. The radiant energy passed through a fused silica wall to a propellant channel. A peak outlet temperature of 4500K was reached, which is equivalent to a specific impulse or 1,350 seconds for hydrogen.

It was shown by a combination of calculations and experiments that internal moderation produced a critical mass reduction (Figure 5).

In a 1.2 megawatt RF facility at the United Technologies Research Center, we used uranium hexafluoride and tungsten hexafluoride as the simulated fuel. We seeded the argon buffer gas with some fluorine gas to react with any fluorides that approached the containment walls. In final experiments, we were getting only milligrams of deposits in tests that ran about 40 minutes. The uranium fluorides are fuel forms that need to be considered for these applications, at least as initial fuel concepts.

A level 3 technology readiness for this concept is estimated.

What are the effects of new technologies (Figure 6)? Certainly modern computational fluid dynamics are going to tell us a lot more. We need to look at nozzle cooling designs and what the upper limit is on specific impulse. There are a whole host of materials that need to be readdressed: coatings, transparent materials, and composites, for example. Space radiator redesign should reduce some weight; we need to look at the reference engine generally with 1990's technology in mind. Mission architectures have changed and we have to work with new regulations with regard to testing, crew safety, and space operations.

Key technical issues include reactor and system stability (Figure 7). We didn't examine failure modes and safety, and we don't have estimates of operating lifetime. Fuel and buffer gas separation, handling and recirculation are areas that also must be addressed.

We don't know much about overall system reliability either. Correlation of fission versus electrically heated tests has to be addressed and verified. We also need to do experiments that validate that you can seed an optically thick plasma and control the spectral distribution of emitted thermal radiation.

We did some missions analysis for a Mars mission back in 1971. The characteristics of the systems used, which of course should be updated, are shown in Figure 8. The assumed transit times were 140 days out and 245 days back, with an 80 day stopover (Figure 9).

The mission required four impulses; one impulse to get there, one to stop at Mars, one impulse to leave and one impulse to return to Earth. The reference engine required an initial mass in Earth orbit that was between a third and a quarter that of the solid core nuclear rocket (Figure 10).

The numbers in parentheses are the number of engines needed to leave Earth, number of engines needed at Mars, number of engines needed to leave Mars and, finally, the number to return. No notation means you can do it all with one engine.

For the next steps (Figure 11 and 12), more fluid dynamic analysis and nozzle cooling design work is needed. We should look at materials such as composites, coatings, transparent wall materials, and evaluate the NASP database to see what kind of materials are of use. We should redesign the reference engine using 1990's technology. Modern mission analysis should be done, as well as environmental assessments of the effects on crews by space and test operations. Then, we should define how to proceed.

What are the critical tests (Figure 13)? Cold flow and more electrically heated tests are needed to develop fuel recirculation and handling systems and also for demonstrations of fluid mechanical confinement. Using the same kinds of tests, we should investigate fuel and buffer gas circulation and reprocessing and measure the effects of spectral tailoring.

In the long term, nuclear criticality tests must be continued. Small scale low power tests and small scale high power tests can be done using the solid core facilities for fuel element tests. You can do a lot of proof-of-concept validation before you have to get to full scale testing.

The key point here is that you can piggyback nuclear light bulb experiments using solid core test reactors and facilities for small scale in-reactor proof-of-concept tests, thereby saving money.

Here is a cut at costs and schedule (Figure 14).

In closing, it's hard to review all the work that was done. But a lot of technology was considered some 10 to 20 years ago and in all cases, the feasibility of the nuclear light

bulb concept continued to be demonstrable.

BIBLIOGRAPHY

Tom Lathan
Nuclear Light Bulb

1. **McLafferty, G.H.:** Investigation of Gaseous Nuclear Rocket Technology -- Summary Technical Report. United Aircraft Research Laboratories Report H-910093-46, prepared under Contract NASw-847, November 1969.
2. **McLafferty, G.H.:** Gas-Core Nuclear Rocket Engine Technology Status. *Journal of Spacecraft and Rockets*, Vol. 7, No. 12, December 1970, p. 1391.
3. **Kendall, J.S.:** Investigations of Gaseous Nuclear Rocket Technology -- Summary technical Report. United Aircraft Research Laboratories Report L-910905-13, prepared under Contract SNPC-70, September 1972.
4. **Kendall, J.S. and T.S. Latham:** Summary of Fluid Mechanics and Engine Characteristics Research on the Nuclear Light Bulb Engine Concept. AIAA Paper No. 70-689, presented at AIAA 6th Propulsion Joint Specialist Conference, San Diego, CA June 1970.
5. **Latham, T.S.:** Summary of Performance Characteristics of the Nuclear Light Bulb Engine. AIAA Paper No. 71-642, presented at the Seventh IAA Propulsion Joint Specialist Conference, Salt Lake City, Utah, June 1971.
6. **Clement, J.D. and J.R. Williams:** Gas Core Reactor Technology. *Reactor Technology*, Vol. 13, No. 3, Summer 1970, pp. 226-251.
7. **Latham, T.S. and R.J. Rodgers:** Analytical Design and Performance Studies of Nuclear Furnace Tests of Small Nuclear Light Bulb Models. United Aircraft Research Laboratories Report L-910900-17, prepared under Contract SNPC-70, September 1972.
8. **Roman, W.C.:** Argon/UF₆ Plasma Experiments: UF₆ Regeneration and Product Analysis. NASA CR 3258. Prepared under NASA Contract NAS1-14329, March 1980.
9. **Latham, T.S. and R.J. Rodgers:** Small Nuclear Light Bulb Engines with Cold Beryllium Reflectors. AIAA Paper No. 72-1093, presented at AIAA/SAE 8th Joint Propulsion Specialist Conference, New Orleans, LA, November 1972.
10. **Jaminet, J.E. and J.S. Kendall:** Vortex-Confined Uranium Hexafluoride Cavity Reactor Experiment. United Technologies Research Center Report R80-914499-4 prepared under Contract X69-5627F-1, April 1980.

SKETCH OF A NUCLEAR LIGHT BULB ENGINE

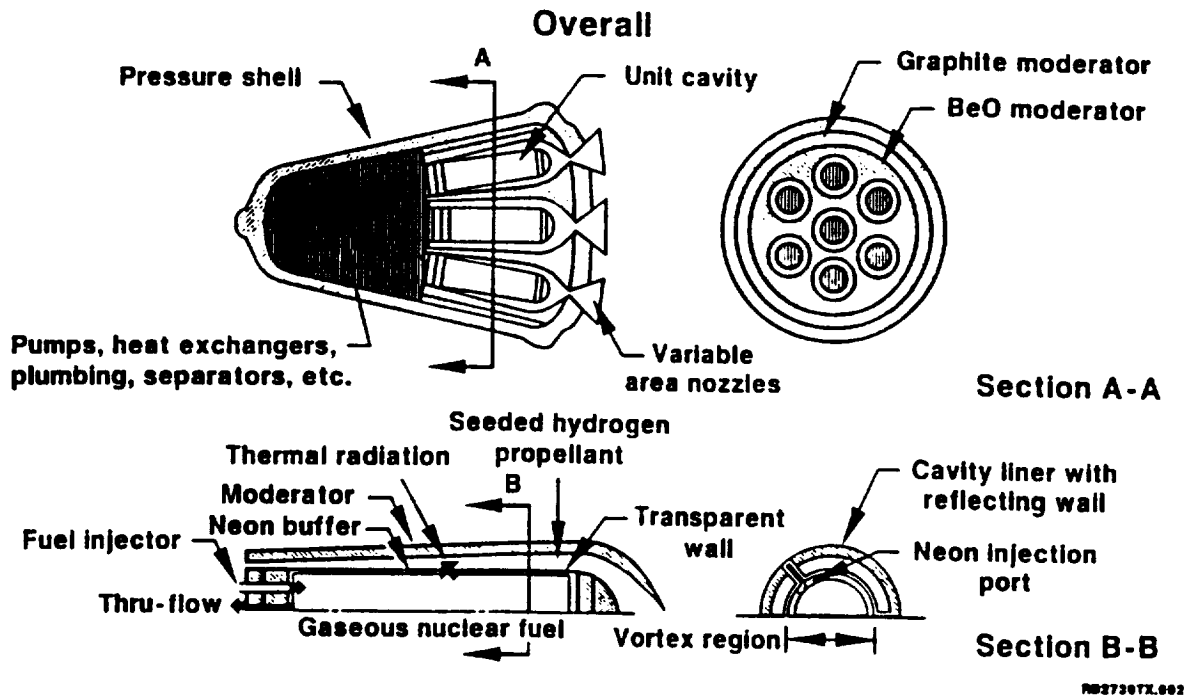

Figure 1

Reference Nuclear Light Bulb Engine Configuration

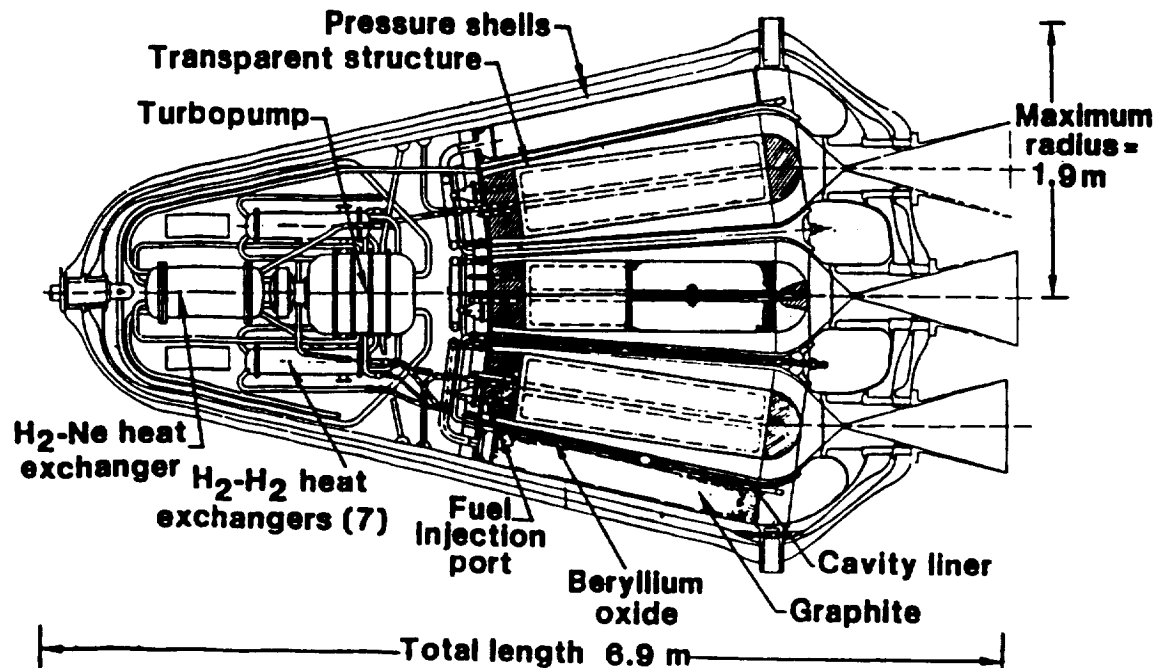

Figure 2

PERFORMANCE CHARACTERISTICS OF REFERENCE NUCLEAR LIGHT BULB ENGINE

Engine weight	70,000 lb
Engine power	4600 MW
Total propellant flow	49.3 lb / sec
Specific impulse	1870 sec
Thrust	92,000 lb
Engine thrust-to-weight ratio	1.3

Figure 3

GAS CORE NUCLEAR REACTOR

Program Achievements

- **Flow Containment Demonstrated**
 - Cold Flow
 - RF Plasma
 - Closed Loop Critical Cavity Assembly
- **Energy Coupling Demonstrated**
 - RF Plasma
 - Radiation Annealing Effect
 - Buffer Gas Tailoring
 - Seeded Propellant Heating Test
 - Equivalent Isp Approx 1350 sec.

GAS CORE NUCLEAR REACTOR

Program Achievements (Cont.)

- **Internal Moderator Benefit Confirmed**
 - **Almost 3:1 Reduction in Critical Mass**
- **Flow Rate Control Demonstrated**
 - **Closed Loop Argon-UF₆ Vortex Flow Syst.**
 - **Los Alamos Critical Cavity Assembly**
 - **Seven Tests**
 - **Achieved 20 KW for Approx. 100 sec.**
 - **No Unexpected Fluctuations**
- **Technology Readiness Level = 3**

Figure 5

IMPACT OF NEW TECHNOLOGIES / SAFETY REGULATIONS

- **Computational fluid dynamics**
- **Cooled nozzle design**
- **Materials**
- **Space radiator design**
- **Reference engine with 1990's technology**
- **Mission architectures**
- **Environmental and crew safety**

KEY TECHNICAL QUESTIONS

- Reactor / system stability over all operating conditions
- Failure modes and safety impacts
- Operating lifetime / performance envelope
- Fuel / buffer gas separation / recirculation system performance
- Overall system reliability
- Correlation of electrically heated demonstrations to fission heated operation
- Validation of spectral tailoring of radiant heat flux

Figure 7

ENGINE SPECIFICATIONS

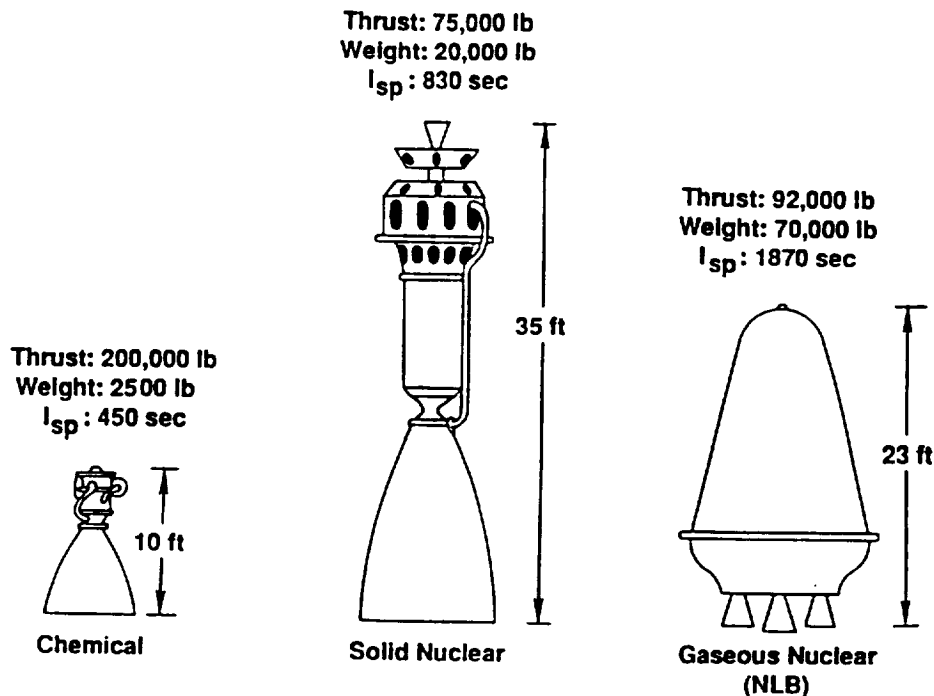

Figure 8

TRAJECTORY PROFILE

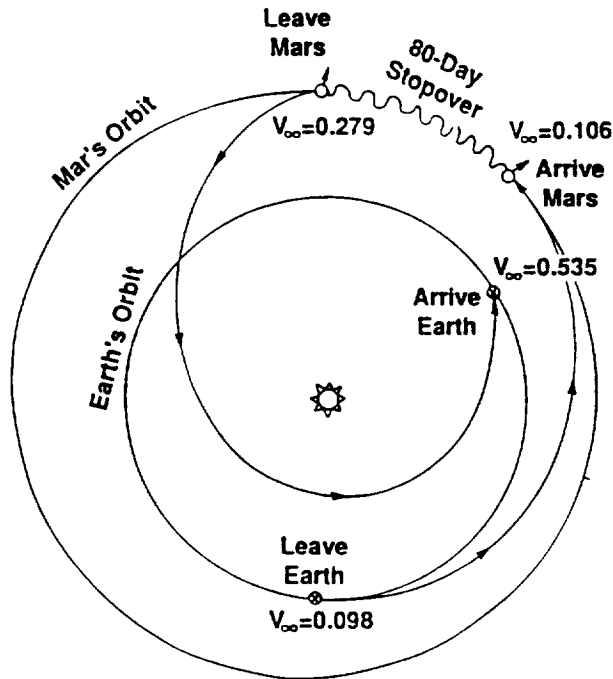

Figure 9

INITIAL MASS REQUIREMENTS

Manned mass mission

Mass in earth orbit, $\text{lb} \times 10^{-6}$

Standard stopover
Stay = 90 days

Payload - 400,000 lb
100,000 lb left at Mars

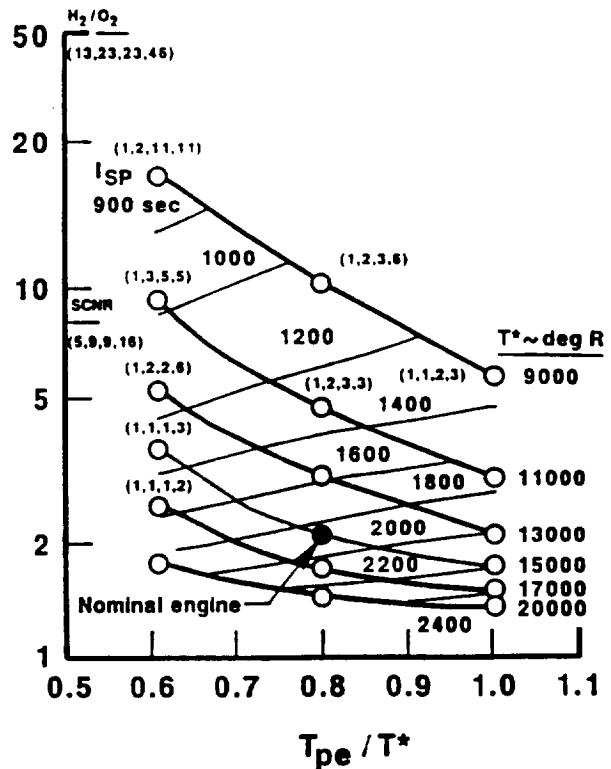

Figure 10

GAS CORE NUCLEAR REACTOR

The Next Step

- **CFD Analysis/Design of Cavity**
- **Cooled Nozzle Design**
- **Materials Evaluation**
 - **Radiation Damage**
 - **Composites and Coatings**
 - **National Aerospace Plane Data Base**
- **Redesign Reference Engine**
 - **1990 Technology Level**
 - **Advanced Turbopump Concepts (SSME)**
 - **Advanced Diagnostics**
 - **Fiber Optics**
 - **Launch and On-Orbit Operations**
 - **Fuel Reprocessing System**
- **Mission Performance Analyses**

Figure 11

GAS CORE NUCLEAR REACTOR

The Next Step (Cont.)

- **Environmental Assessment**
 - **Earth Development Facilities**
 - **Launch Facilities and On-Orbit Operations**
 - **Operations and Crew Impact**
 - **Direct - Radiation Exposure, Vehicle Design**
 - **Indirect - Mission Profile, Duration**
 - **Lunar and Planetary Outposts**
- **Test Options Evaluation**
- **Test Program/Facilities Definition**

Figure 12

