

025921-23-T

FINAL REPORT:
A NEW TECHNIQUE FOR SIMULATING COMPOSITE MATERIAL

John L. Volakis

210-217-11

P-98

NASA-Ames Research Center
Moffett Field, CA 94035
Grant NAG-2-541

September 1991



THE UNIVERSITY OF MICHIGAN

**Radiation Laboratory
Department of Electrical Engineering
and Computer Science
Ann Arbor, Michigan 48109-2122
USA**

(NASA-CR-188792) A NEW TECHNIQUE FOR
SIMULATING COMPOSITE MATERIAL Final Report,
Sep. 1988 - Sep. 1991 (Michigan Univ.)
73 p CSCL 11D

N92-11140

Unclas
G3/24 0039574

FINAL REPORT
FOR
NASA Grant NAG-2-541
NASA Technical Monitor: Alex Woo

Grant Title: A New Technique for Simulating Composite Material

Institution: The Radiation Laboratory
Department of Electrical Engineering
and Computer Science
The University of Michigan
Ann Arbor, MI 48109-2122

Period Covered: September 1988 - September 1991 (Final Report)

Report Author: J.L. Volakis

Principal Investigator: John L. Volakis
Telephone: (313) 764-0500

Table of Contents

Introduction	1
Project Objectives	2
Payoff	3
Funding Profile	4
Project Milestones	5
Second Year Milestones	6
Third Year Milestones	7
First Year Progress Summary	8
Second Year Progress	9
Third Year Progress	11
Summary of Accomplishments	13
Future Work	14
Presentation Viewgraphs	16
Appendix A: List of Journal Articles	49
Appendix B: Reports List	52
Abstracts of Technical Reports	54

Introduction

This is a summary progress report of the NASA three-year Grant NAG 2-541 which was initiated in September 1988. This research project dealt with the development of new methodologies and algorithms for the multi-spectrum electromagnetic characterization of large scale non-metallic airborne vehicles and structures. As can be readily attested from the appended results of our research, a new robust, low memory and accurate methodology was developed which is particularly suited for modern machine architectures. This is a hybrid finite element method and combines two well known numerical solution approaches. That of the finite element method for modeling volumes and the boundary integral method which yields exact boundary conditions for terminating the finite element mesh. In addition, a variety of new high frequency results were generated (such as diffraction coefficients for impedance surfaces and material layers) and a new class of boundary conditions were developed which hold promise for more efficient simulations. During the course of this project nearly twenty five detailed research reports were generated (totalling more than 1000 pages) along with an equal number of journal papers. The reports, papers and journals articles are listed in the appendices of this report along with their abstracts. The University of Michigan Radiation Laboratory report 025921-22-T is intended to provide a technical summary of the developed hybrid finite element method. A shorter version of this report has also appeared in the April 1991 issue of the *IEEE Antennas and Propagation Transactions Magazine*.

Below we summarize our progress on a year by year basis with recommendation on the continuation of this project. However, before doing so, a short statement of the project's initial goals and their importance to NASA and the Navy is given.

Project Objectives

- Implement a new formulation for scattering by two-dimensional(2D) and three-dimensional(3D) composite structures. At present, there is no available methodology for modeling large size non-metallic vehicles for electromagnetic characterization purposes.
- New method is a modified version of the finite element method and claims a low $O(n)$ memory demand making it attractive for large body simulations without any restrictions on the structure's composition.
- Develop 2D and 3D general purpose codes and associated graphical user interfaces based on the new methodology.
- Develop a new class of generalized impedance boundary conditions (GIBC) to allow the simulation of thin multilayer material coatings. These are to be incorporated with the finite element codes to model such coatings or to be used in place of absorbing boundary conditions(ABCs)
- Develop diffraction coefficients for new geometries based on the proposed GIBCs.
- Develop 2D and 3D numerical solutions based on the proposed GIBCs

Payoff

- Proposed work will allow the simulation of three-dimensional composite vehicles and structures for test and evaluation.
- To date, no other methodology can claim an $O(n)$ memory demand without a compromise in accuracy and versatility.
- No technique is presently available for treating 3D composite/penetrable structures
- Because it provides near zone and far zone field distributions, it will also serve as a diagnostic tool in evaluating the effectiveness of surface treatments.
- Complete, general purpose codes will be developed along with associated graphical user interfaces to be used in the test and evaluation of practical size vehicles.

- The proposed generalized impedance boundary conditions should prove important in modeling high contrast RAM material either in the context of the proposed hybrid finite element method or in high frequency modelling.

Funding Profile

YEAR	AMOUNT		
	PMTC.	Univ.Mich.	Total
	(Cost Sharing)		
1988-89	\$50,000	\$29,000	\$79,000
1989-90	\$50,000	\$29,000	\$79,000
1990-91	\$100,000	\$25,000	\$125,000

Project Milestones

First Year Milestones

- Develop 2-D formulation for the proposed hybrid finite element method (FE-CGFFT)
- Implement and test methodology by comparison with results based on traditional approaches
- Assess method's advantages and potential for future 3D implementations

-
- Develop higher order boundary conditions (GIBC) aimed at improving the simulation of multilayer coatings
 - Test accuracy and limitation of these boundary conditions
 - Begin development of new canonical analytical solutions by making use of the developed GIBC.

Second Year Milestones

- Develop geometry generation package to be interfaced with the developed 2D hybrid finite element code.
 - Develop graphical user interface(GUI) for the 2D code, compatible with X-window platforms.
 - Start development of the proposed 3D hybrid finite element method (FE-CGFFT).
 - Apply FE-CGFFT method to a restricted class of 3D geometries; Test and evaluate method.
 - Develop analysis and begin code development for general Bodies of Revolutions (BOR) based on the new method.
-
- Develop new diffraction coefficients based on the GIBC;
Test and evaluate these for incorporation into GTD codes.
 - Develop 2D numerical solutions based on the derived GIBC.

Third Year Milestones

- Complete and validate Body of Revolution Code and associated Graphical User Interface.
- Develop edge-based shape functions and discretize equations using tetrahedral and other six-sided elements.
- Develop test codes using the boundary integral or the ABCs for a simple structure such as a finite cylinder.
- Develop and test other more accurate ABCs if necessary
- Validate test codes by comparison with BOR moment method codes
- Begin interfacing with 3D graphics packages such as SDRC IDEAS® and PATRAN®.

-
- Develop 3D numerical codes using simulations based on the Generalized Impedance Boundary Conditions(GIBCs)
 - Continue development of high frequency solutions

First Year Progress Summary

- Developed analysis and associated computer code for 2D scattering using the proposed finite element-boundary integral method in conjunction with the conjugate gradient-FFT (FE-CGFFT)
- Wrote user interface and 2D mesh generation package.
- Validated new code for rectangular structures and found its efficiency to be in accordance with original expectations.

-
- Developed generalized impedance boundary conditions (GIBC) for multilayer material coatings on curved bodies.
 - Implemented and tested the developed GIBC for scattering by 2D coated bodies; A new numerical code was developed.
 - Generated a new canonical diffraction coefficient for skew incidence on impedance wedges. This diffraction coefficient will later prove to be of crucial importance in high frequency analysis of composite structures.

-
- Five detailed reports were written on the above accomplishments.
 - Seven journal papers were submitted for publication and many conference publications resulted from this year's effort.

Second Year Progress

- Developed formulation and code for scattering by 3D rectangular cavities, cracks and slots using the proposed FE-CGFFT method. Code demonstrated the method's unprecedented low memory, efficiency and versatility.
- Made several improvements to the 2D FE-CGFFT code developed last year:
 - Developed new color graphics compatible with X-window platforms (post-processing tools).
 - Developed a new 2D mesh generator - AUTOMESH (pre-processing tool)
 - Validated code for a variety of composite geometries of arbitrary shape.
 - Determined that method's convergence can be improved by resorting to higher order boundary elements.
- Developed the three dimensional FE-CGFFT analysis for Bodies of Revolution (BOR).
- New BOR code was written and is being debugged.
- Examined a number of commercial 3D mesh generation packages and found SDRC IDEAS@ to be most useful for this method.
- Developed new high frequency solutions for metal-dielectric junctions made possible by using the generalized impedance boundary conditions.

- Constructed a numerical solution based on the generalized boundary conditions for scattering by 2D cracks and gaps and impedance surfaces.

-
- A total of fifteen(15) reports have been written during the first two years of this project.
 - More than twelve(12) journal papers have been published or submitted based on this work.
 - Many conference papers have also been presented.

Third Year Progress

- Validated the Body of Revolution(BOR) Code and we are now improving its convergence characteristics by making use of higher order boundary elements.
- Developed 3D finite element codes for non-rectangular and inhomogeneously filled cavities.
- Developed new improved Absorbing Boundary Conditions (ABCs) to be used in conjunction with the proposed finite element solution.
- Formulated new edge-based tetrahedral elements suitable for electromagnetic simulations. Coded and tested formulation for modeling closed cavities
- The development of a general purpose 3D finite element - ABC code using tetrahedral elements is nearly complete.

-
- New diffraction coefficients were generated for dielectric-to-dielectric junctions using the developed GIBCs.
 - The non-uniqueness of GIBCs was investigated and resolved for a number of cases.
 - Developed solutions for creeping and surface waves on multilayer dielectrics. A code was also written and tested.
 - Developed a 3D formulation and code for multilayer dielectric coatings using the developed GIBCs.

-
- Twenty two (22) reports totalling more than 1200 pages have been written so far as a result of this effort.
 - Over thirty journal papers have been written to date.
 - Over twenty conference papers have also been written and presented.

Summary of Accomplishments

During the course of this study we have developed and validated a new method for scattering by composite vehicles. The method has proven superior to existing approaches by requiring a low $O(n)$ storage without compromising the accuracy of the solution. So far, up to 150,000 unknown systems have been solved via the method with rather remarkable convergence rates.

Based on this method, a general purpose scattering code was written along with a mesh generator compatible with X window platforms. A Body of Revolution code was also written as a first step in moving toward a full scale three dimensional implementation. At this point the three-dimensional finite element formulation has been developed and coded for edge-based elements which are best suited for electromagnetic simulations. A three dimensional code based on a new class of absorbing boundary conditions should be ready within one to two months. The accuracy of this code will be examined before proceeding with the incorporation of the exact boundary integral equations for terminating the mesh.

In addition to the development of the new numerical method, a rather successful study was carried out pertaining to the development of improved impedance boundary conditions and diffraction coefficients for impedance and material edges. These were crucial in improving the capability of existing high frequency codes. In addition, they provide an

efficient and elegant simulation of thin layers and impedance surfaces in the context of finite element solutions.

Future Work

During the previous grant we developed and tested the proposed hybrid finite element method (FE-CGFFT). The method was applied to a variety of 2D and some 3D applications but by and large this initial study was concerned with the development and validation of the method. However, the full potential of the method remains to be explored and this should be the driving goal of the next effort. It is essential that the full 3D implementation of the method be completed as planned and be applied for a characterization of new large scale composite geometries. New discretization elements should be examined and implemented in a manner that leads to improved system conditions. Further, preconditioning schemes should be examined and new solvers for vector and multi-processor architectures be explored for solving very large systems involving millions of unknowns. A major advantage of the proposed methodology is its suitability for solution on multi-processor architectures and this feature should be explored to its maximum. Finally, the role of pre- and post-processing software should not be ignored. When dealing with large structures, the generation of geometry discretization files is a major, time consuming task and must be well integrated with the analysis code. Also, the processing and presentation of the multi-spectral RCS or near field data present us with a challenging task and ways must be developed

to effectively display the information contained by such data.

PRESENTATION VIEWGRAPHS
ON THE
FORMULATION, VALIDATION AND
APPLICATION OF THE
HYBRID FINITE ELEMENT-CGFFT METHOD

Geometries where the proposed Finite Element-Boundary Element has been Applied

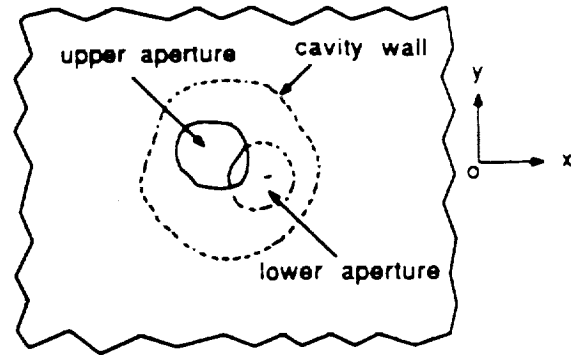
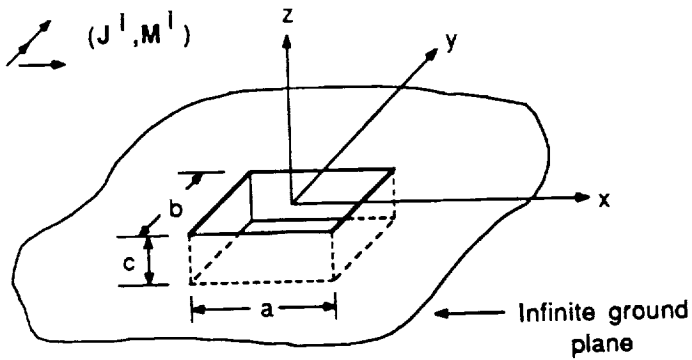
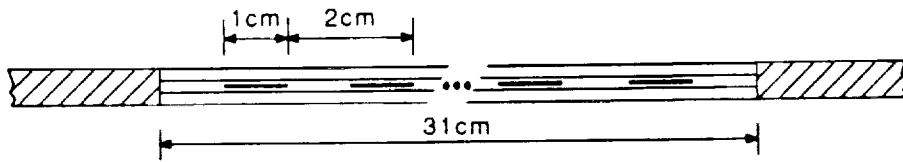
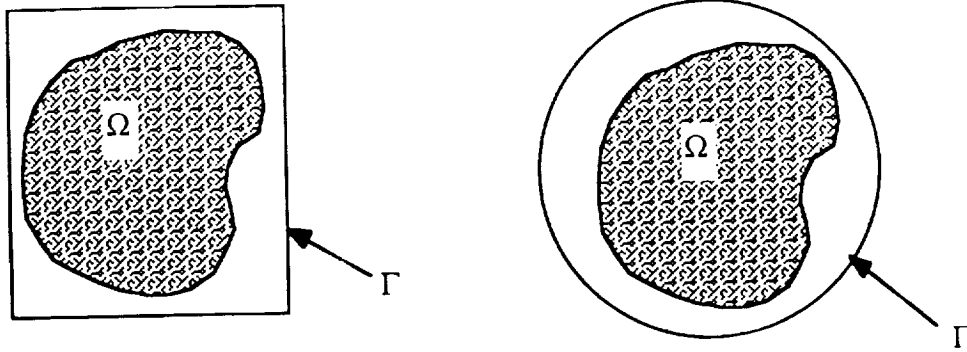

Top View

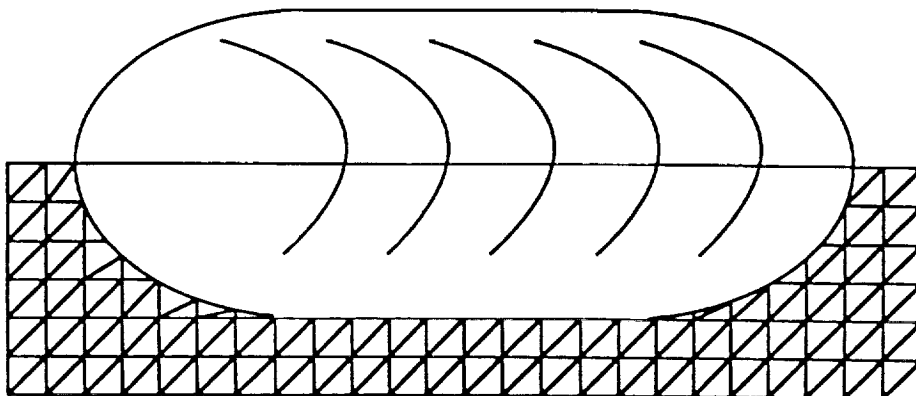

k-SPACE / CONJUGATE GRADIENT FFT

METHODOLOGY

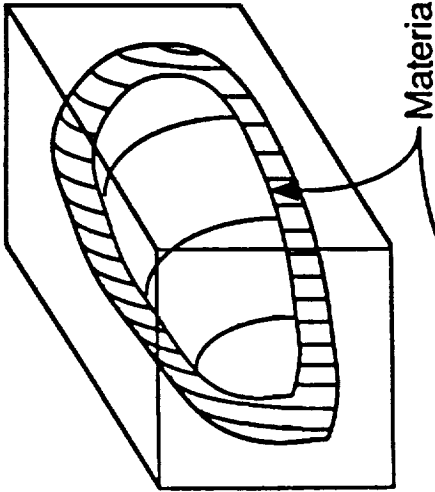

- Target is fitted in uniform rectangular grid / mesh
- Discretize Fields and Integral Equation
- Evaluate integrals via FFT to avoid matrix generation
- Solve iteratively

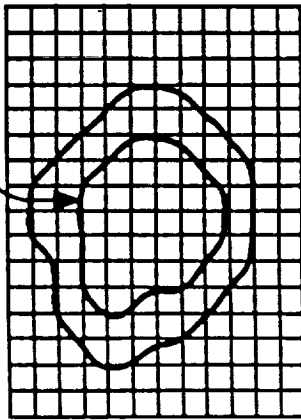

Advantages

- Low memory demand $O(N)$
- Exact formulation
- Convergence Guaranteed
- Simple discretization

Disadvantages

- Must solve system for each look angle
- Requires 3-D FFTs
- Slow in generating patterns
- Uniform rectangular gridding including impenetrable portions (with some exceptions)
- Staircasing
- May converge slowly unless conditioned.

Finite Element-Boundary Integral CGFFT Hybrid Method

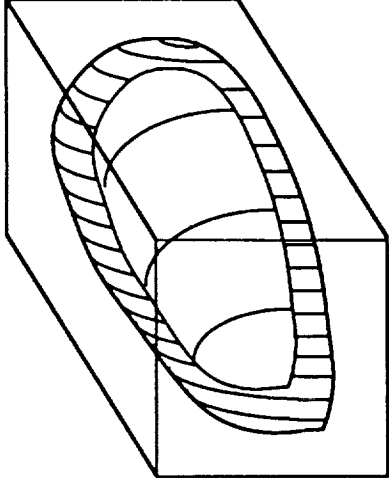

Why Hybrid?

- To eliminate gridding within hard boundaries
- To avoid non-conformed gridding
- To improve CPU time per iteration
- Maintain $O(N)$ memory demand

Description of one Approach

- Enclose target in a tight cubic box (cuboid)
- Employ Finite Element Method to relate fields on structure to those of the cuboid \rightarrow banded matrix
- Employ Boundary Integral equation to relate fields between Γ and Γ_b
- Use 2-D FFTs to evaluate boundary integrals avoiding matrix generation
- Solve system via the CGFFT.

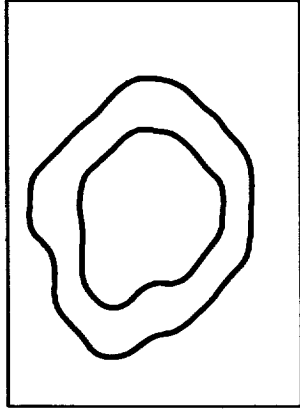

2-D cross-section

Formulation of the Proposed Finite Element-Boundary Element Method

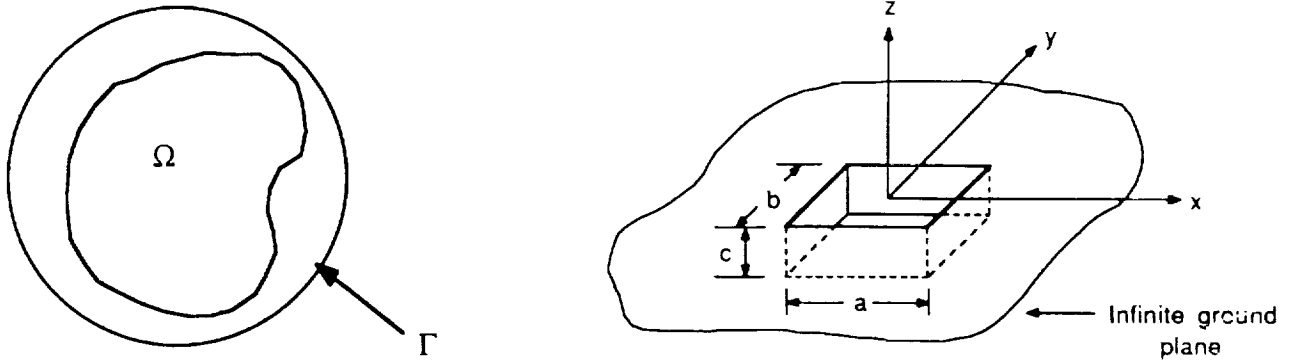

- Tightly enclose structure by a contour (for 2D) or a surface (for 3D). This enclosure separates the infinite space into region Ω and Ω_∞ .
- Formulate and Discretize the field in the interior region Ω via the finite element method.
 - use triangles for 2D
 - use tetrahedra or bricks for 3D
- Employ the Boundary integral equation on Γ to relate the tangential fields. Discretize this i.e. via the Boundary Element method.
- Combine the Finite element and boundary element matrices to solve for the modal or element fields.
- If Γ is kept flat or circular, the boundary integrals are convolutional.
- By using an iterative solution algorithm to solve the system, the FFT can be employed to evaluate the convolutional boundary integrals leading to an $O(n)$ storage requirement.

Finite Element Formulation

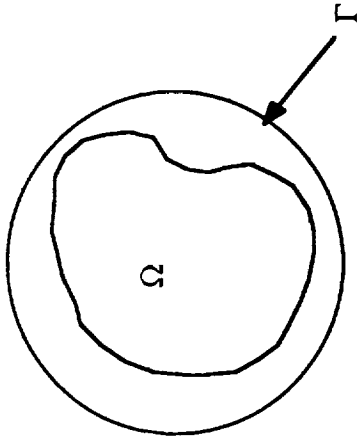

Solve \mathbf{E} such that

$$\delta F(\mathbf{E}) = 0 \quad \text{in } \Omega$$

where

$$F(\mathbf{E}) = \frac{1}{2} \int_{\Omega} \left[\frac{1}{\mu_r} (\nabla \times \mathbf{E}) \cdot (\nabla \times \mathbf{E}) - k_0^2 \epsilon_r \mathbf{E} \cdot \mathbf{E} \right] d\Omega + j k_0 Z_0 \oint_{\Gamma} \mathbf{E} \cdot (\mathbf{H} \times \hat{\mathbf{n}}) d\Gamma$$

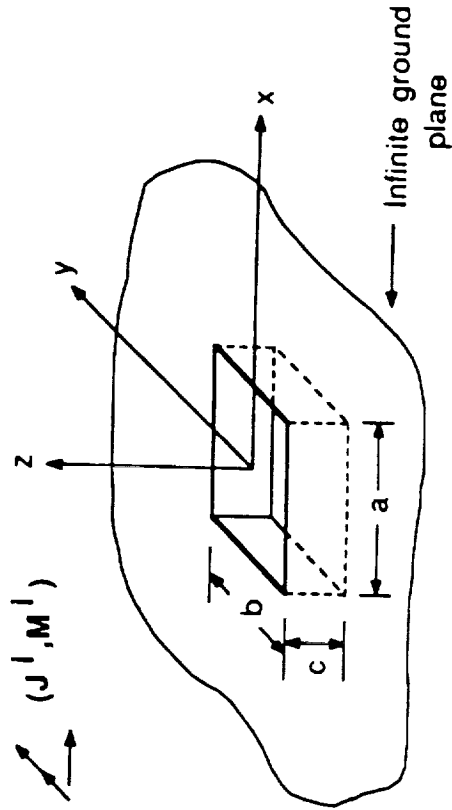

Linear interpolation:

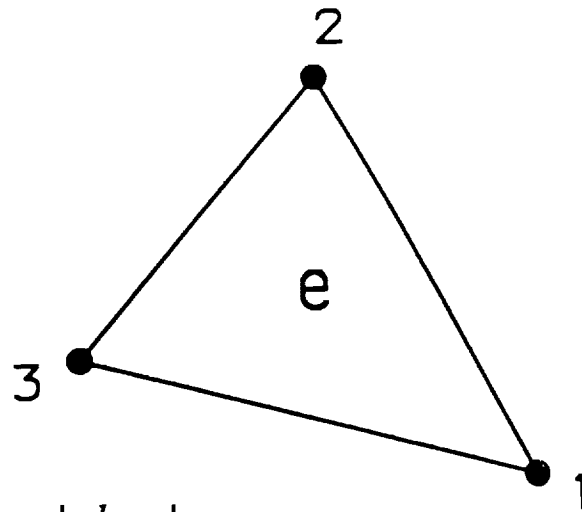

Assume

$$\phi^e(x, y) = a + bx + cy$$

Then

$$\phi^e(x, y) = \sum_{i=1}^3 N_i^e(x, y) \phi_i^e$$

where

$$N_i^e(x, y) = \frac{1}{2\Delta^e} (a_i + b_i x + c_i y)$$

and

$$a_1 = x_2 y_3 - y_2 x_3 ; \quad b_1 = y_2 - y_3 ; \quad c_1 = x_3 - x_2$$

$$a_2 = x_3 y_1 - y_3 x_1 ; \quad b_2 = y_3 - y_1 ; \quad c_2 = x_1 - x_3$$

$$a_3 = x_1 y_2 - y_1 x_2 ; \quad b_3 = y_1 - y_2 ; \quad c_3 = x_2 - x_1$$

$$\Delta^e = \frac{1}{2} \begin{vmatrix} 1 & x_1 & y_1 \\ 1 & x_2 & y_2 \\ 1 & x_3 & y_3 \end{vmatrix} = \text{area of the } e\text{th element}$$

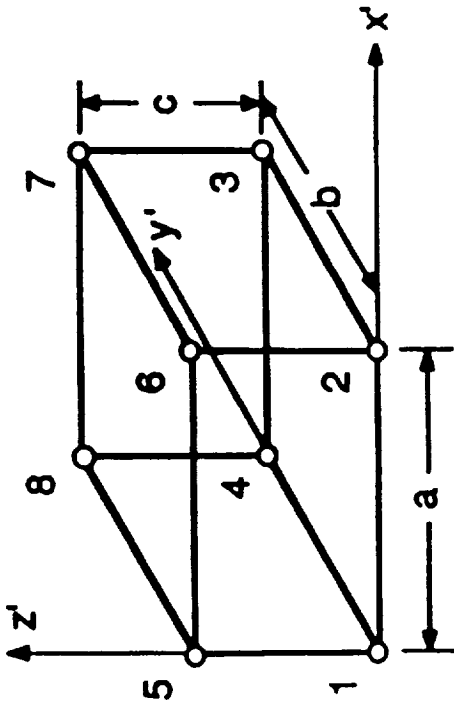

$$E_x = \sum_{j=1}^4 N_{xj}^e(y, z)\phi_{xj}^e; \quad E_y = \sum_{j=1}^4 N_{yj}^e(z, x)\phi_{yj}^e; \quad E_z = \sum_{j=1}^4 N_{zj}^e(x, y)\phi_{zj}^e$$

$$N_{x1}^e = \frac{(b-y')(c-z')}{bc}; \quad N_{x2}^e = \frac{y'(c-z')}{bc}; \quad N_{x3}^e = \frac{(b-y')z'}{bc}; \quad N_{x4}^e = \frac{y'z'}{bc}$$

$$N_{y1}^e = \frac{(c-z')(a-x')}{ca}; \quad N_{y2}^e = \frac{z'(a-x')}{ca}; \quad N_{y3}^e = \frac{(c-z')x'}{ca}; \quad N_{y4}^e = \frac{z'x'}{ca}$$

$$N_{z1}^e = \frac{(a-x')(b-y')}{ab}; \quad N_{z2}^e = \frac{x'(b-y')}{ab}; \quad N_{z3}^e = \frac{(a-x')y'}{ab}; \quad N_{z4}^e = \frac{x'y'}{ab}$$

Discretization of the Functional $F(\mathbf{E})$

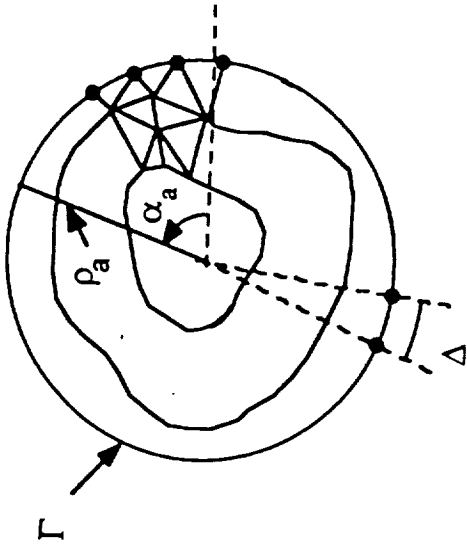

$$\mathbf{E} \text{ (or } \mathbf{H}) = \sum_{e=1}^{M_d} \mathbf{E}^e \text{ (or } \mathbf{H}^e) \approx \sum_{e=1}^{M_d} \sum_{j=1}^{n_d} N_j^e \mathbf{E}_j^e \text{ (or } \mathbf{H}_j^e) \approx \sum_{j=1}^{N_d} N_j^g \mathbf{E}_j \text{ (or } \mathbf{H}_j)$$

$$\mathbf{E} \times \hat{\mathbf{n}} \text{ (or } \mathbf{H} \times \hat{\mathbf{n}}) = \sum_{e=1}^{M_b} \mathbf{E}^e \times \hat{\mathbf{n}} \text{ (or } \mathbf{H}^e \times \hat{\mathbf{n}})$$

$$\approx \sum_{e=1}^{M_b} \sum_{j=1}^{n_b} L_j^e \mathbf{E}_j^e \times \hat{\mathbf{n}} \text{ (or } \mathbf{H}_j^e \times \hat{\mathbf{n}})$$

$$\approx \sum_{j=1}^{N_b} L_j^g \mathbf{E}_j \times \hat{\mathbf{n}} \text{ (or } \mathbf{H}_j \times \hat{\mathbf{n}})$$

$$[\bar{\mathbf{A}}_e]_{N_d \times N_d} \bullet \{\mathbf{E}\}_{N_d \times 1} + [\bar{\mathbf{B}}_e]_{N_b \times N_b} \bullet \{\mathbf{H} \times \hat{\mathbf{n}}\}_{N_b \times 1} = 0$$

$$(\bar{\mathbf{A}}_e)_{ij} = \int_{\Omega} [(\nabla \times N_i^g \bar{\mathbf{I}}) \bullet (\nabla \times N_j^g \bar{\mathbf{I}}) - k_0^2 \epsilon_r N_i^g N_j^g \bar{\mathbf{I}}] d\Omega$$

$$(\bar{\mathbf{B}}_e)_{ij} = j k_0 Z_0 \oint_{\Gamma} L_i^g L_j^g \bar{\mathbf{I}} \cdot d\Gamma$$

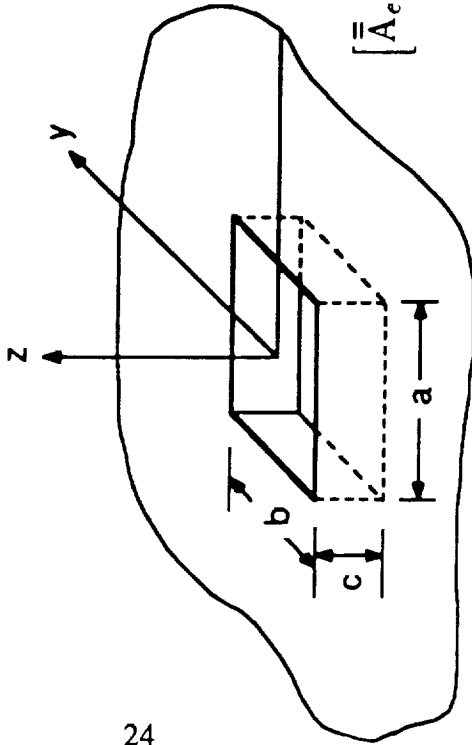

Boundary Integral Formulation

$$\mathbf{E} = \mathbf{E}^i + L_{e1}^s (\mathbf{E} \times \hat{\mathbf{n}}) + L_{e2}^s (\mathbf{H} \times \hat{\mathbf{n}})$$

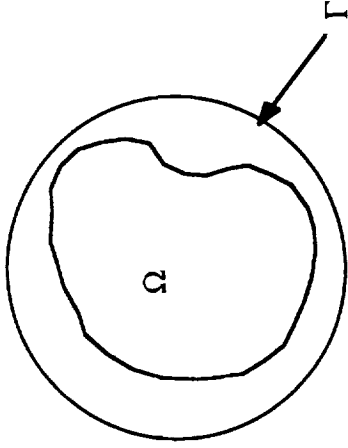

For 2D

$$\mathbf{E}_z = \mathbf{E}_z^i + \int_{\Gamma} \left\{ \mathbf{E}_z(\rho') \frac{\partial \mathbf{g}_0}{\partial n'} + \mathbf{g}_0 \frac{\partial \mathbf{E}_z(\rho')}{\partial n} \right\} d\Gamma'$$

For 3D

$$\mathbf{E} = \mathbf{E}^i(\mathbf{r}) + \iint_S \left\{ \nabla \times \bar{\bar{\mathbf{G}}}_0(\mathbf{r}, \mathbf{r}') \bullet [\mathbf{E}(\mathbf{r}') \times \hat{\mathbf{n}}'] - jk_0 Z_0 \bar{\bar{\mathbf{G}}}_0(\mathbf{r}, \mathbf{r}') \bullet [\mathbf{H}(\mathbf{r}') \times \hat{\mathbf{n}}'] \right\} dS'$$

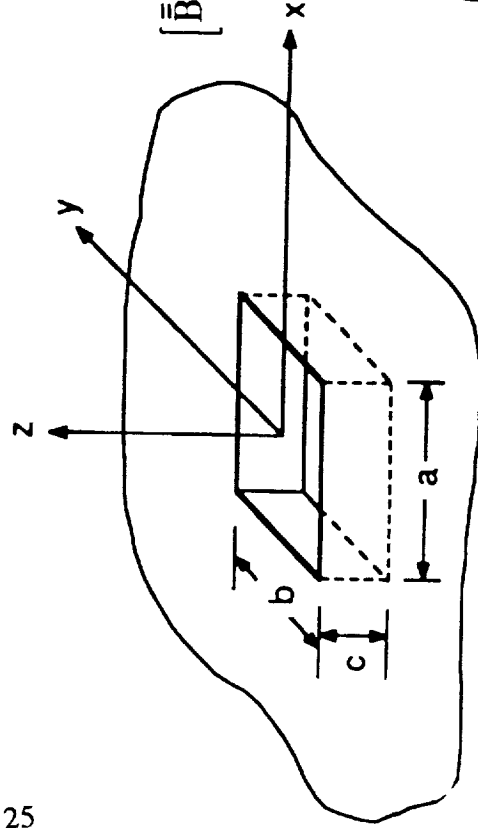

Discrete System:

$$[\bar{\bar{\mathbf{B}}}_h]_{N_b \times N_b} \bullet \{\mathbf{E} \times \hat{\mathbf{n}}\}_{N_b \times 1} + [\bar{\bar{\mathbf{P}}}_{e1}]_{N_b \times N_b} \bullet \{\mathbf{E} \times \hat{\mathbf{n}}\}_{N_b \times 1} + [\bar{\bar{\mathbf{P}}}_{e2}]_{N_b \times N_b} \bullet \{\mathbf{H} \times \hat{\mathbf{n}}\}_{N_b \times 1} = \{\mathbf{b}_e\}_{N_b \times 1}$$

$$(\bar{\bar{\mathbf{P}}}_{e1,2})_{ij} = -jk_0 Y_0 \oint_{\Gamma} L_i^g \hat{\mathbf{n}} \times L_j^s (\mathbf{L}_j^g \bar{\mathbf{I}}) d\Gamma$$

$$(\mathbf{b}_e)_i = jk_0 Y_0 \oint_{\Gamma} L_i^g \hat{\mathbf{n}} \times \mathbf{E}^i d\Gamma$$

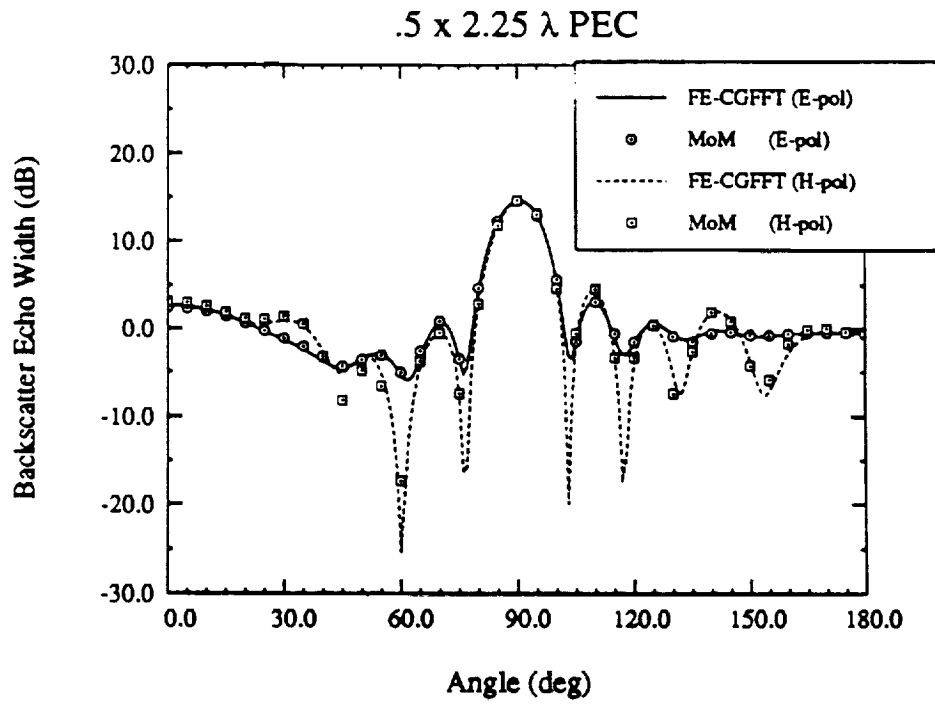
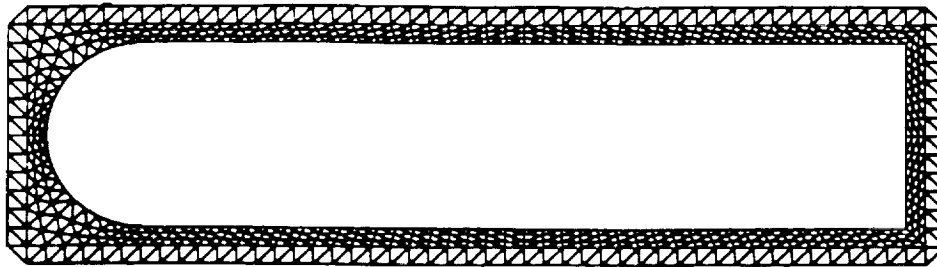
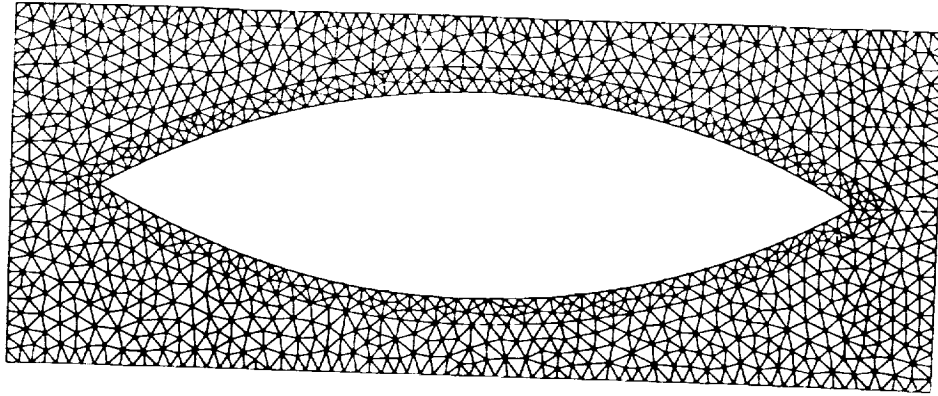
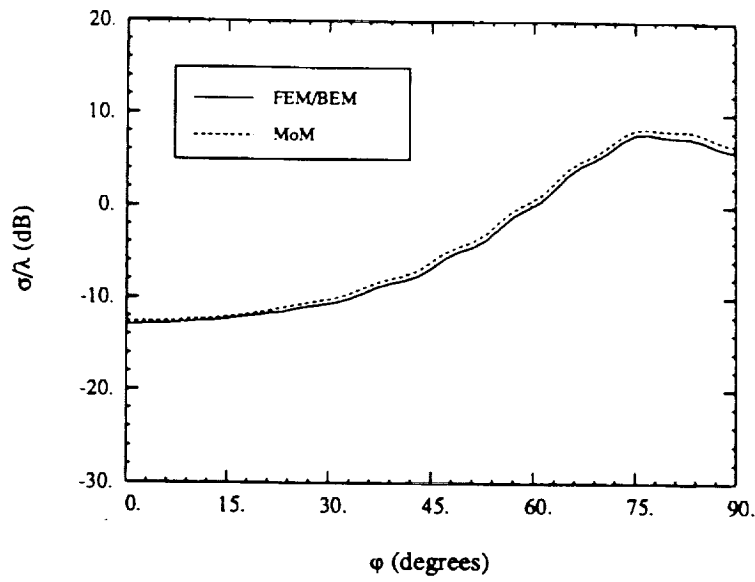

Figure 1: E_z and H_z backscatter echowidth patterns for the illustrated perfectly conducting cylinder.



E-pol



(a)

H-pol

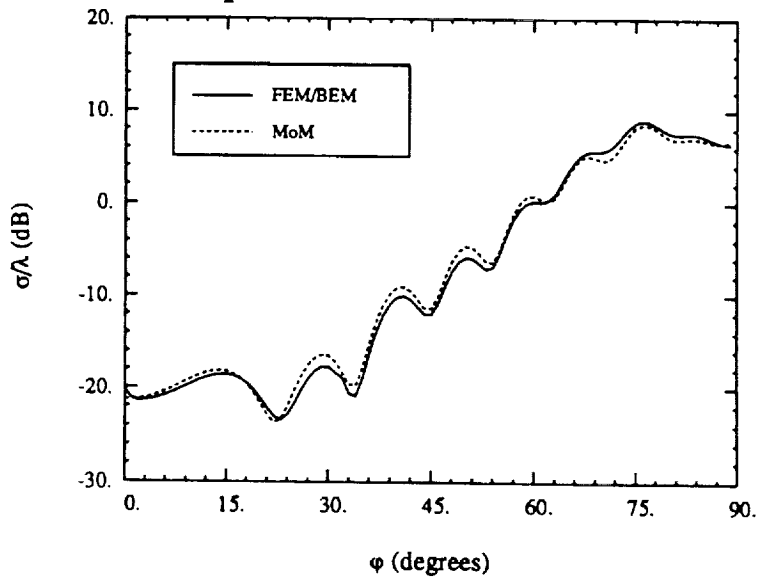

(b)

Coated Ogive
 $4\lambda \times 1\lambda$
 0.05λ coating
 $\epsilon_r = 3 - j5$
 $\mu_r = 1.5 - j0.5$

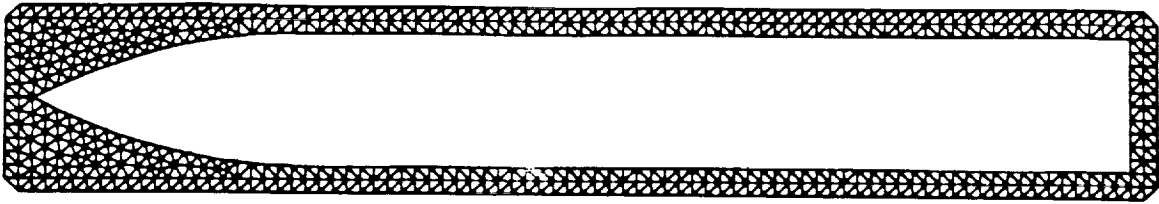

FILE: missile_out
 CREATION DATE: 1 Aug 1990
 STRUCTURE: missile shape
 ENCLOSURE: rectangle

 number of nodes: 636
 number of elements: 908
 nodes on pec boundary: 172
 nodes on obs boundary: 192

 nodes on unknowns (E-pol): 464
 nodes on unknowns (H-pol): 636

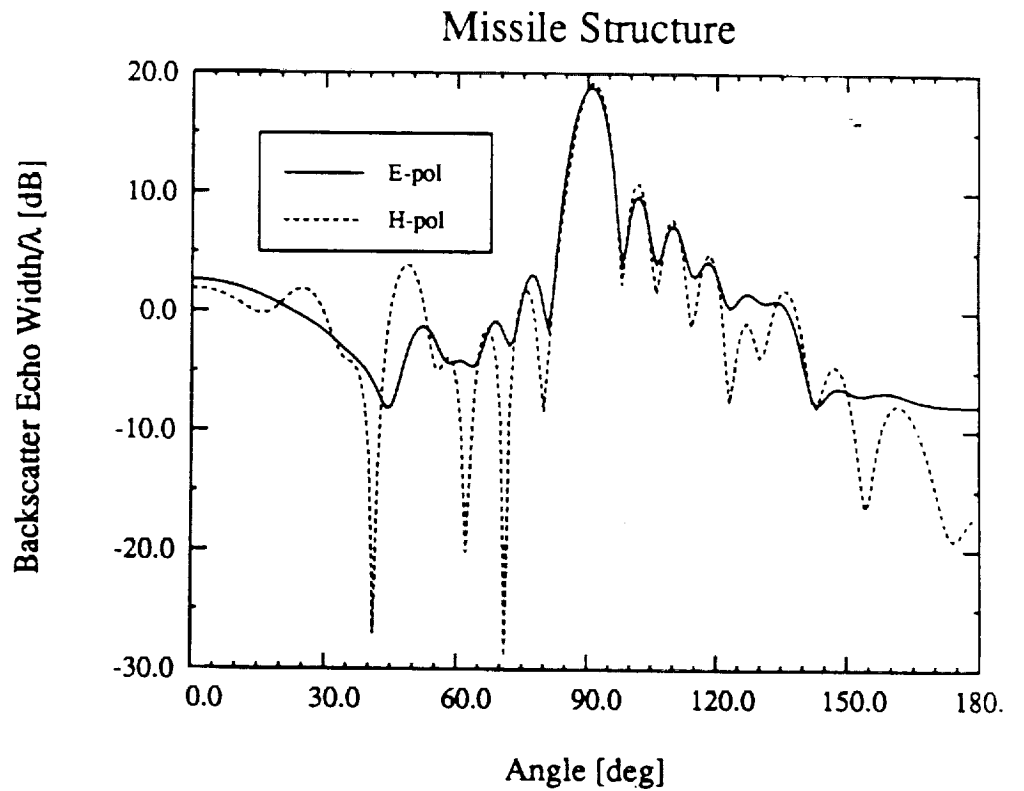

Figure 7: Backscatter patterns for a missile-like perfectly conducting and coated cylinder.

COATED OGIVE

$$0.05\lambda \text{ coating } \begin{pmatrix} \epsilon_r = 5 - j3 \\ \mu_r = 1.5 - j0.5 \end{pmatrix}$$

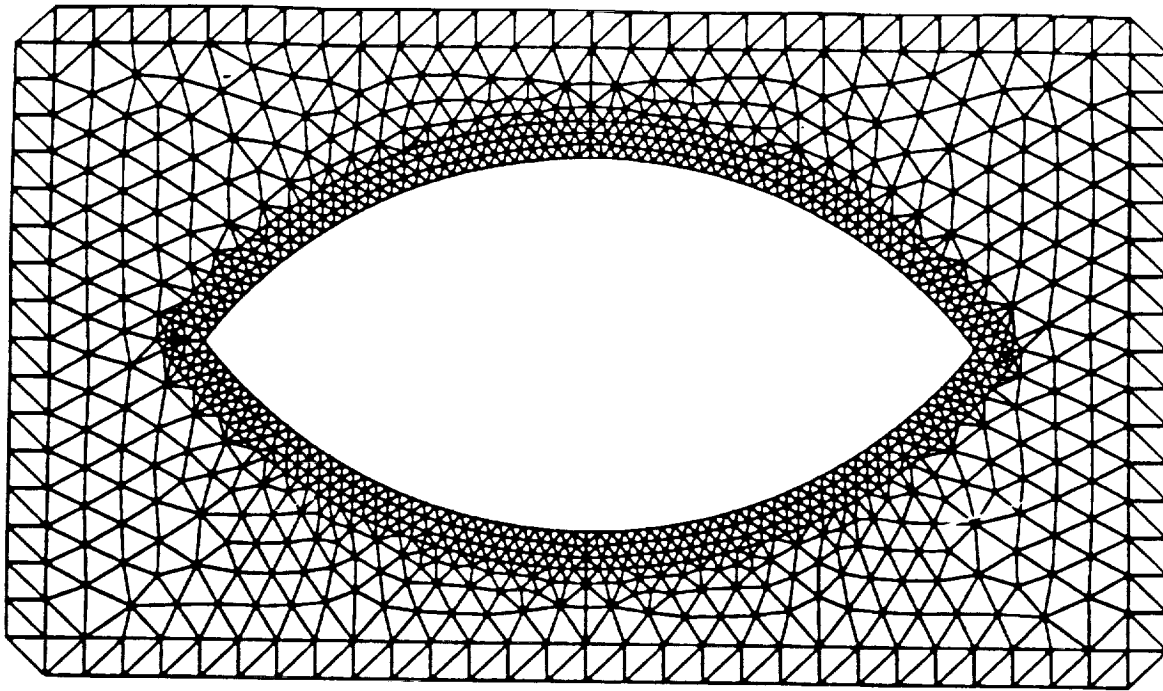

Figure 2(b): Example of a rectangular mesh enclosing a coated ogive.

FILE: ogive_leo_out
CREATION DATE: 7 Aug 1990
STRUCTURE: 0.5 x 1 λ coated conductor
ENCLOSURE: rectangle
number of nodes: 1084
number of elements: 1936
nodes on pec boundary: 140
nodes on obs boundary: 92
nodes on unknowns (E-pol): 944
nodes on unknowns (H-pol): 1084

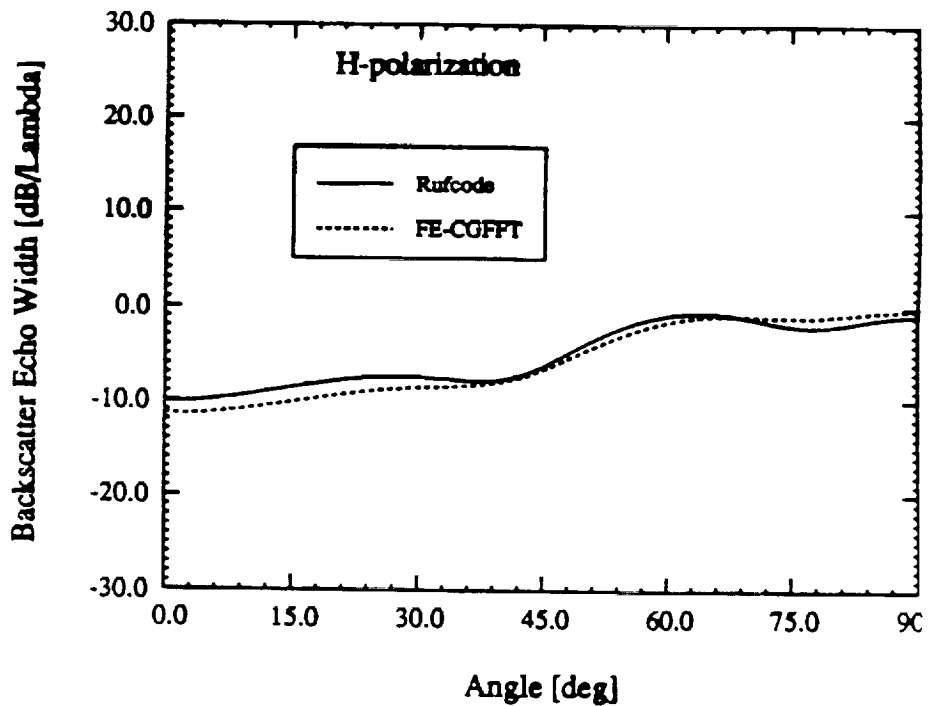

Figure 2(c): H-polarization backscatter pattern for the coated ogive in Fig. 2(b).

Coated Trailing Edge FEM Mesh

case 2

$$y_{\text{in}} = \begin{cases} \pm \frac{1}{2} \sqrt{1 - (x/2.5)^2} & -2.5 \leq x \leq 0 \\ \pm 0.8232 A(x) & 0 \leq x \leq 2.5 \end{cases}$$

$$A(x) = \sqrt{\left(1 - (x/2.7182)^2\right)} - 0.3926$$

$$y_{\text{out}} = \pm 0.8116 B(x) \quad 0.1 \leq x \leq 3.0$$

$$B(x) = \sqrt{1 - [(x-.1)/3.1416]^2} - .3846$$

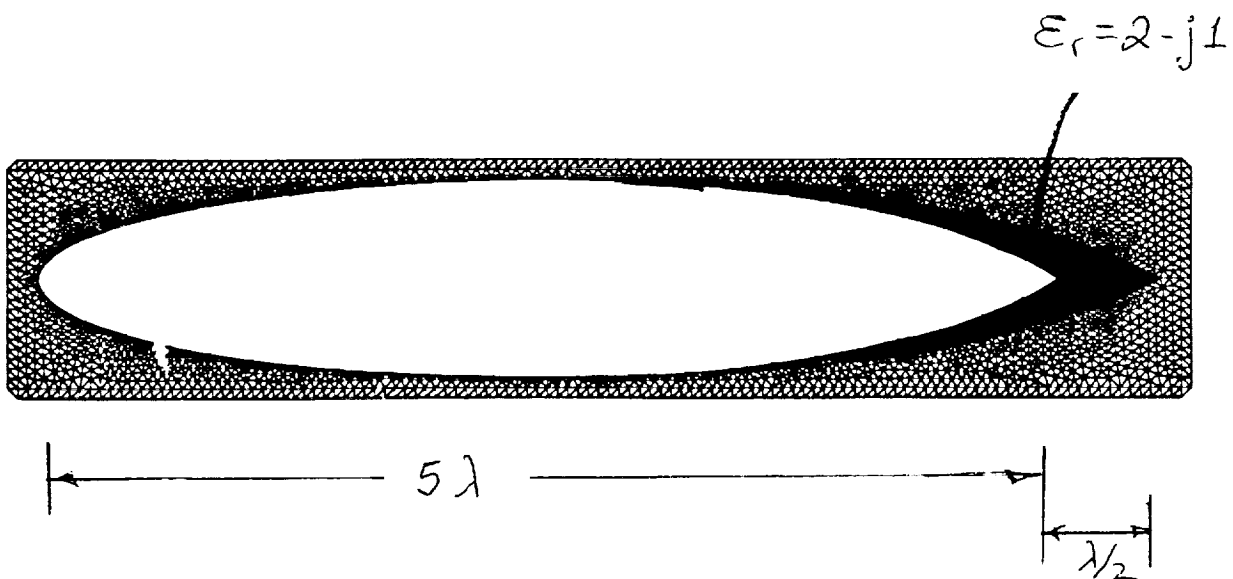

Case 2: Coated trailing edge, ($\epsilon=2-j1$), H-pol

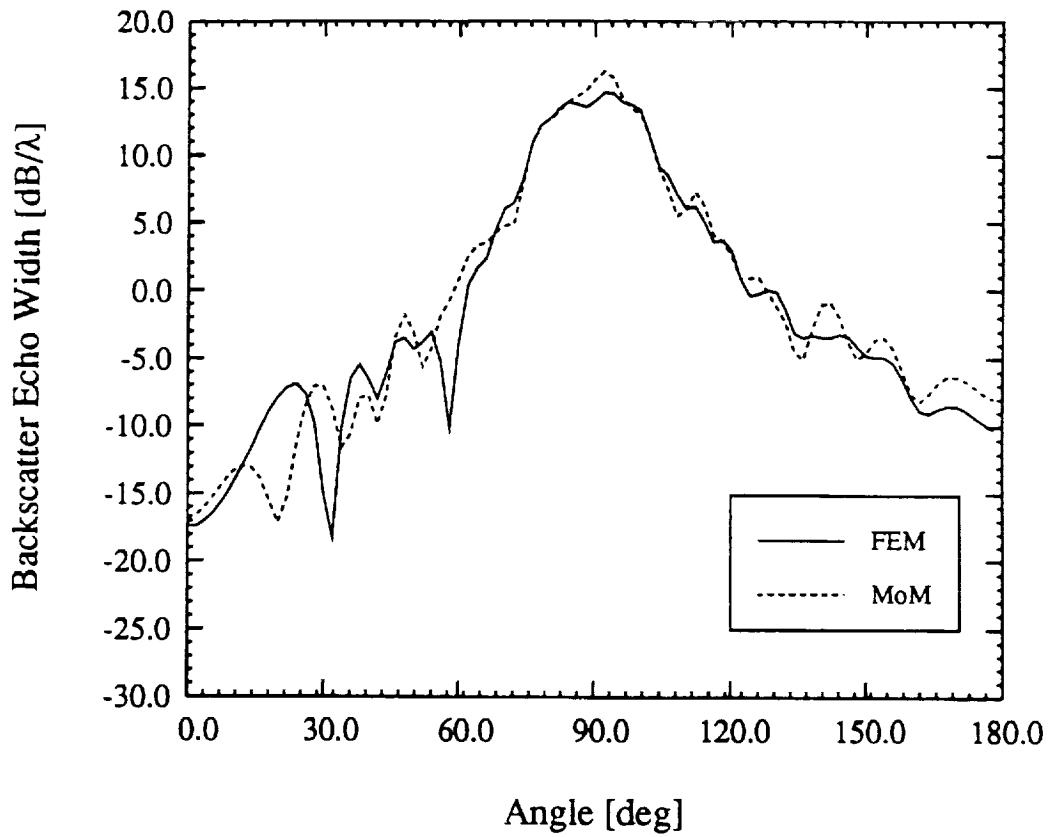

Case 2: Coated trailing edge, ($\epsilon=2-j1$), E-pol

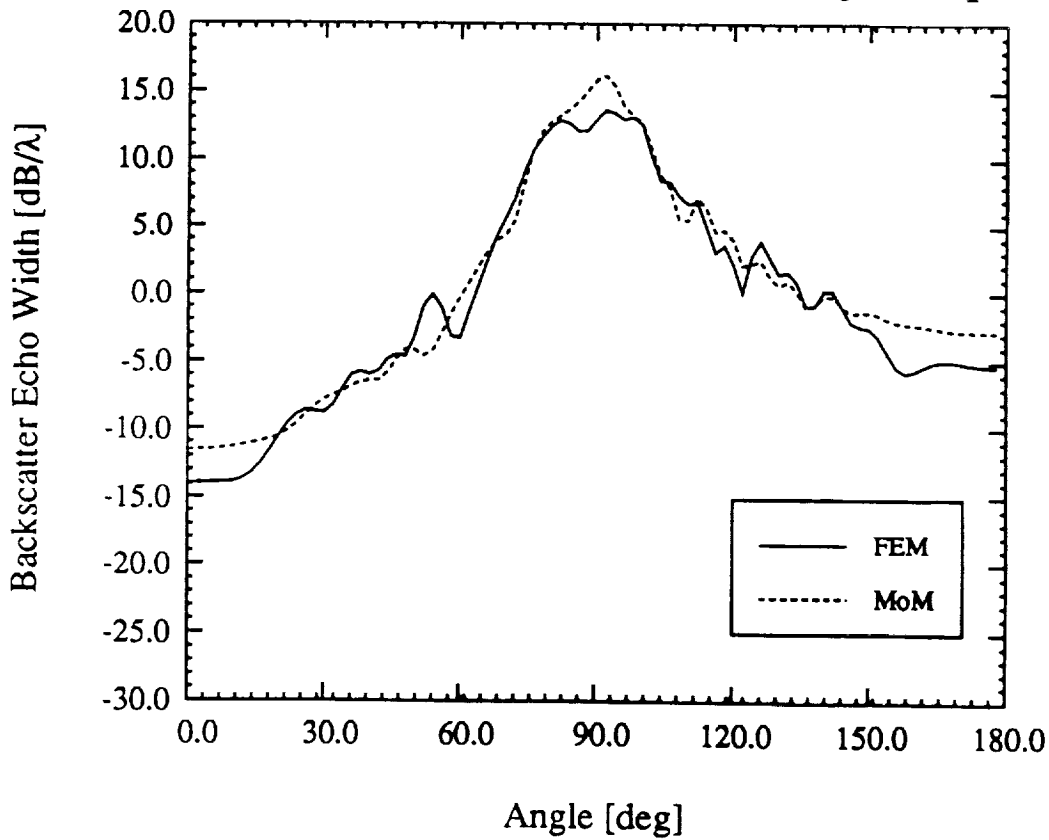

H-polarization

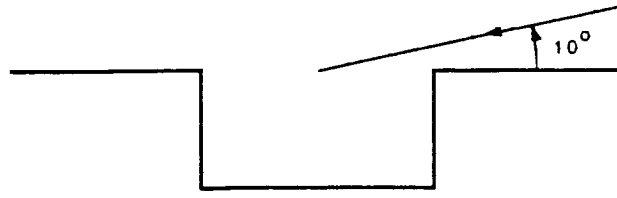

Groove
Width: 2.5cm
Depth: 1.25cm

CALCULATED

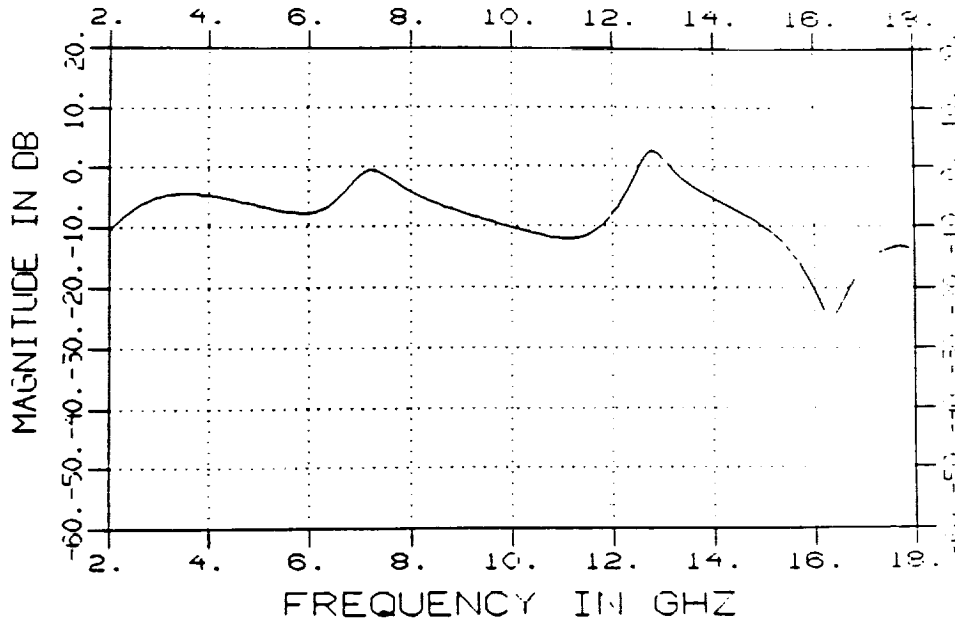

MEASURED

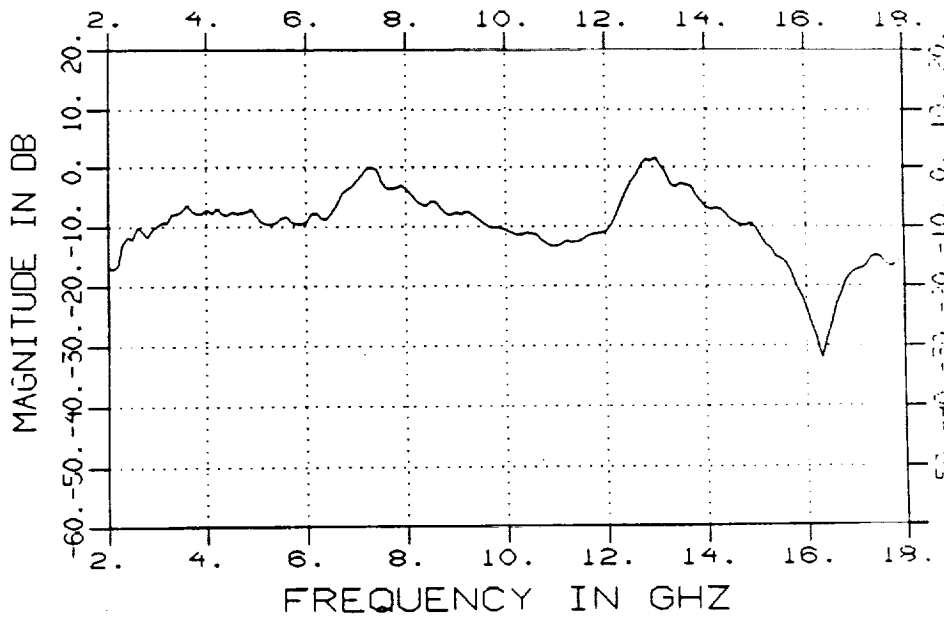

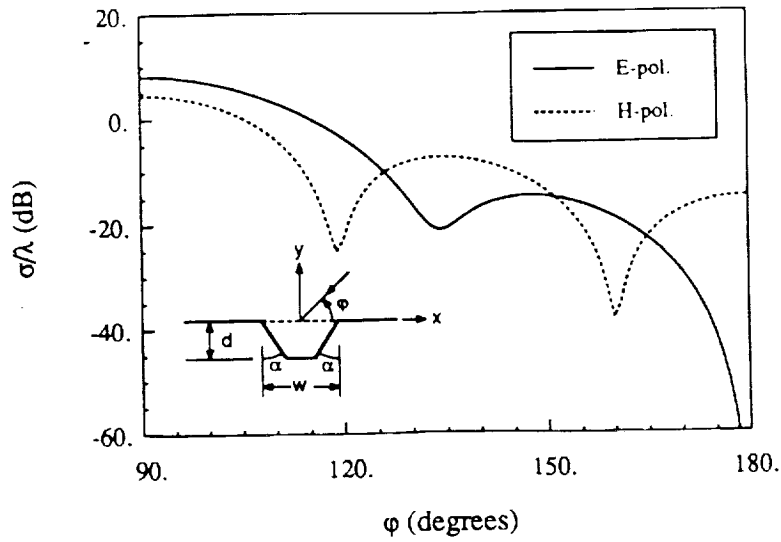

Backscatter patterns for a groove having a trapezoidal cross-section and filled with a material having $\epsilon_r = 2.56 - j0.256$, $\mu_r = 1.2 - j0.1$; $w = 1\lambda$, $d = 0.5\lambda$, $\alpha = 30^\circ$.

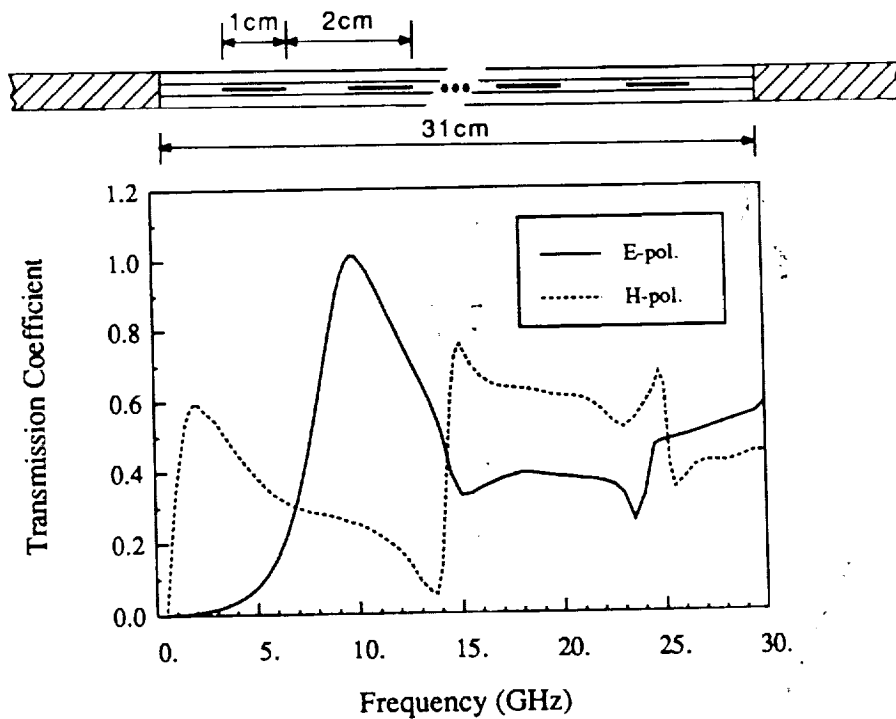
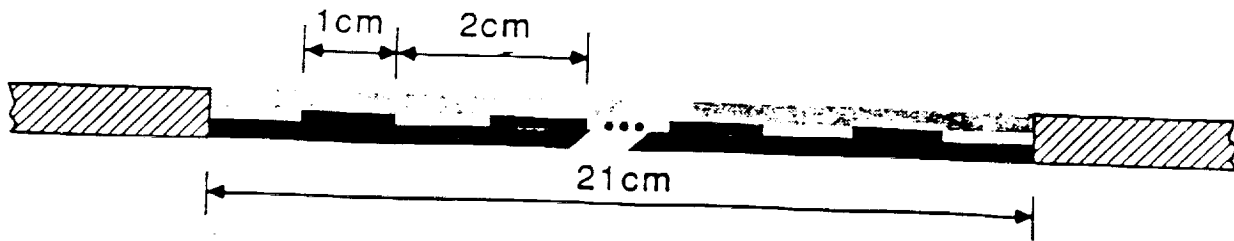
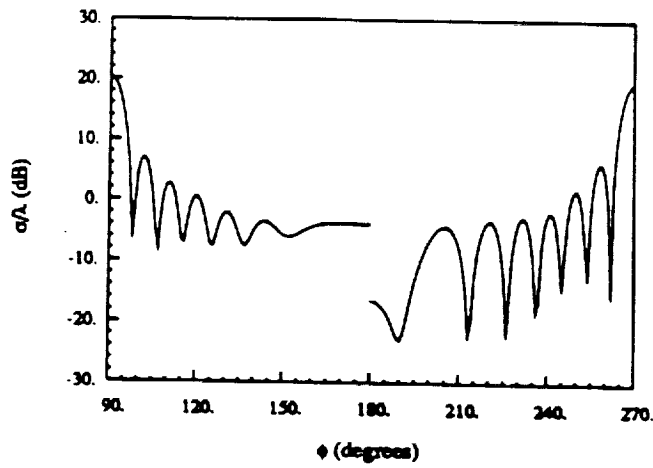

Illustration of an aperture filled with three dielectric layers and a strip grating. Top and bottom layers: $\epsilon_r = 2.56$, $\mu_r = 1.0$, 0.2 cm thick; middle layer: $\epsilon_r = 4.0$, $\mu_r = 1.0$, 0.2 cm thick.



$\epsilon_r=2.56$, $d=0.2\text{cm}$
 $\epsilon_r=4$, $d=0.2\text{cm}$
 strip, $d=0.1\text{cm}$



10 GHz

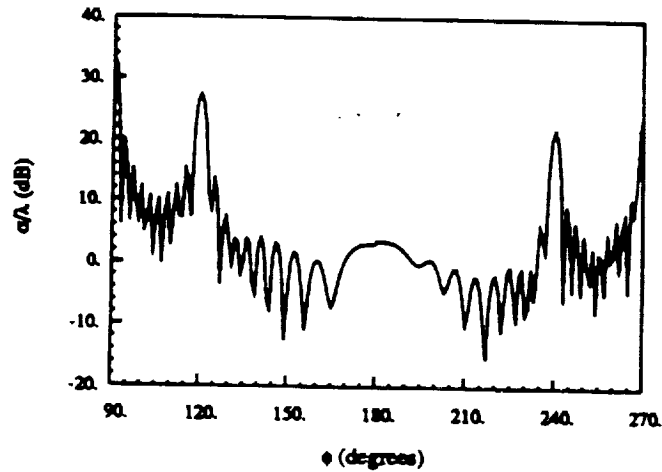

39 GHz

Normal Incidence

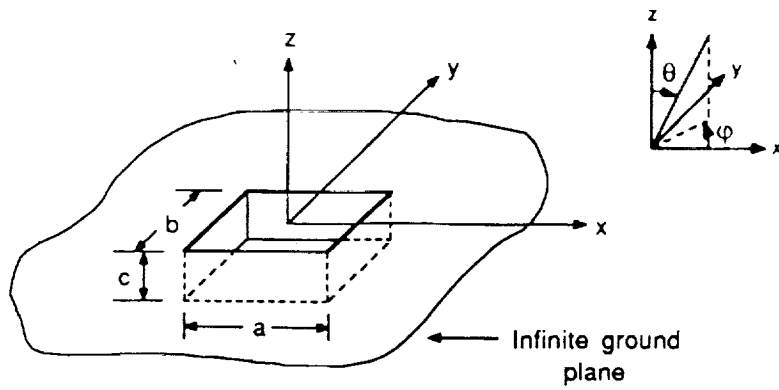

$c = 0.25 \lambda$ material filling
 $a = 1 \lambda$ $\epsilon_r = 7 - j0.5$ (a) = $\phi = 90^\circ$
 $b = 0.25 \lambda$ $\mu_r = 1.8 - j.01$ (b) = $\phi = 0^\circ$

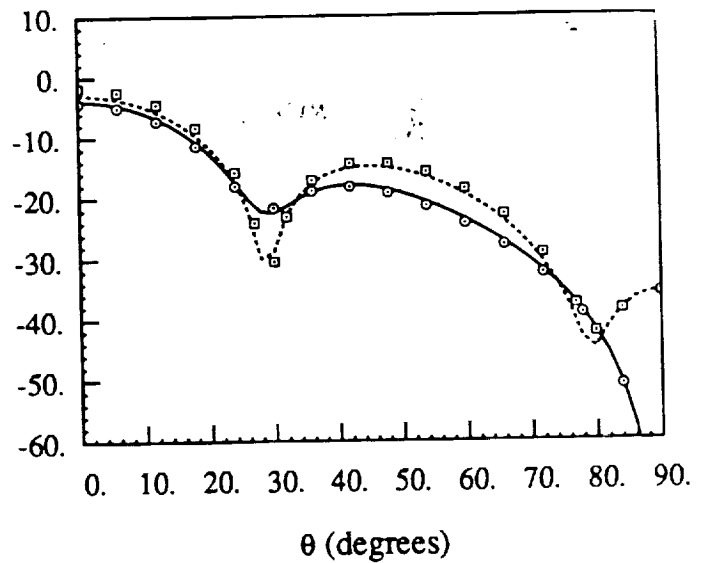
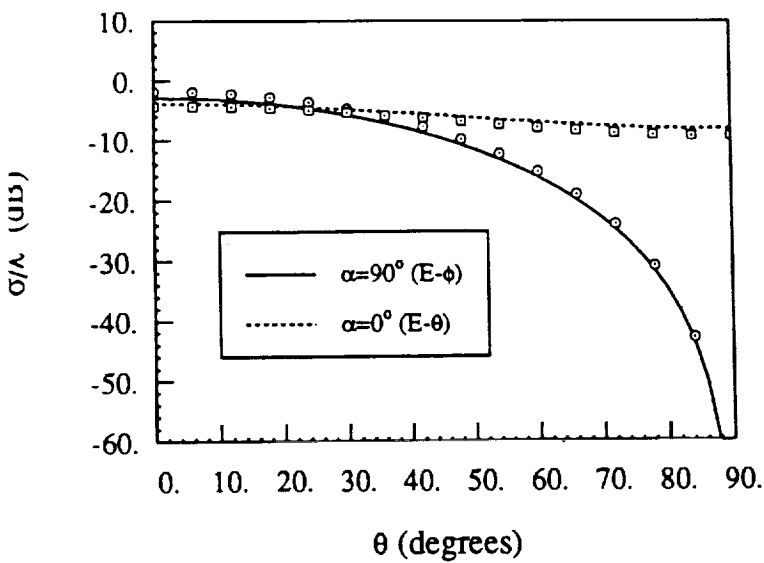

Backscatter patterns for a material-filled cavity versus incidence angle; $a = 1.0 \lambda$, $b = 0.25 \lambda$, $c = 0.25 \lambda$, $\epsilon_r = 7.0 - j0.5$, $\mu_r = 1.8 - j0.1$. Solid and dashed lines represent the solution of this method; circles and squares represent the moment method/modal solution. (a) $\varphi = 90^\circ$. (b) $\varphi = 0^\circ$.

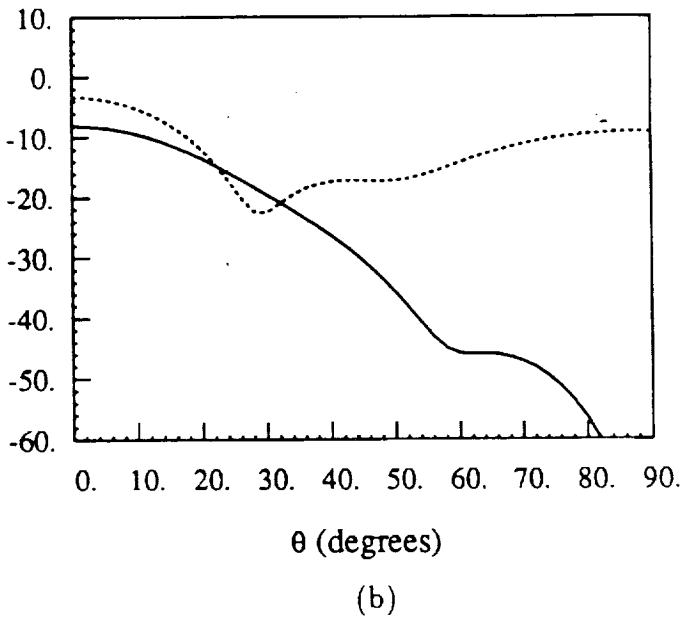
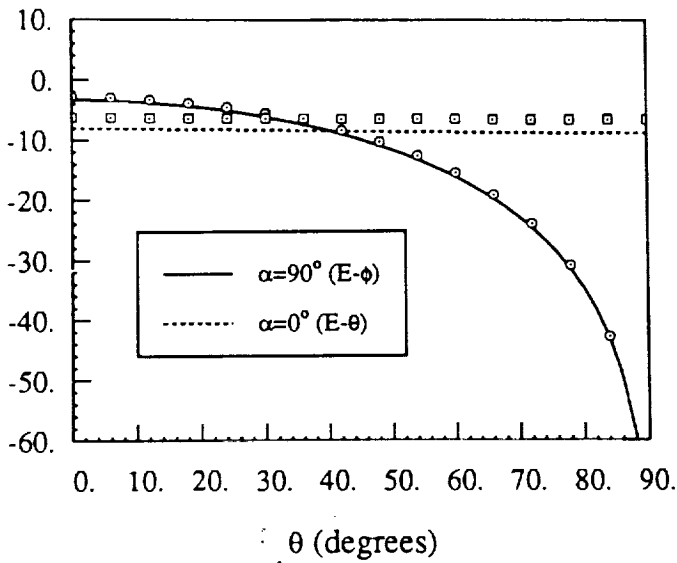
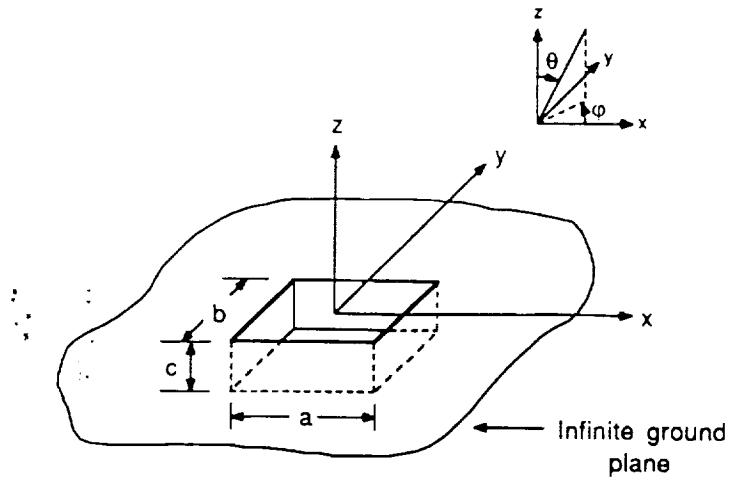

Backscatter patterns for a multilayer material-filled cavity versus incidence angle; $a = 1.0\lambda$, $b = 0.25\lambda$, $c = 0.25\lambda$. Top layer: $\epsilon_r = 7.0 - j0.5$, $\mu_r = 1.8 - j0.1$, 0.0625λ thick; middle layer: $\epsilon_r = 3.0 - j0.05$, $\mu_r = 2.0$, 0.125λ thick; bottom layer: $\epsilon_r = 5.0 - j0.03$, $\mu_r = 1.0$, 0.0625λ thick. Solid and dashed lines represent the three-dimensional solution; circles and squares represent the two-dimensional solution. (a) $\varphi = 90^\circ$. (b) $\varphi = 0^\circ$.

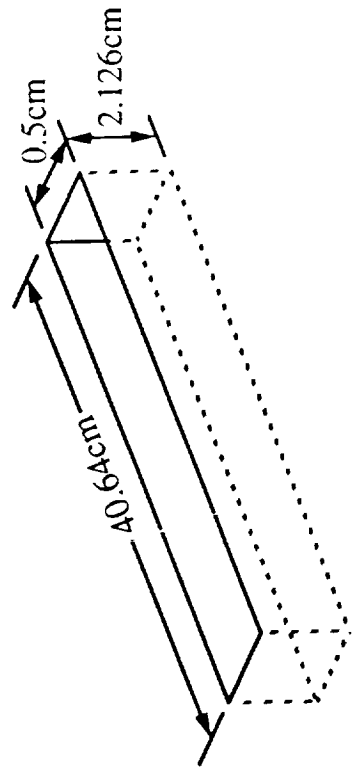
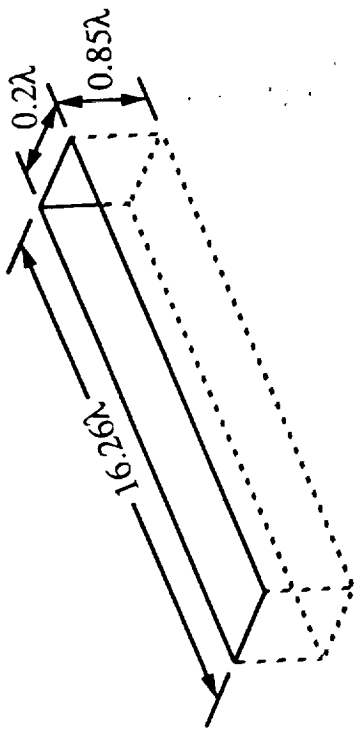

Comparison with OSU measurements

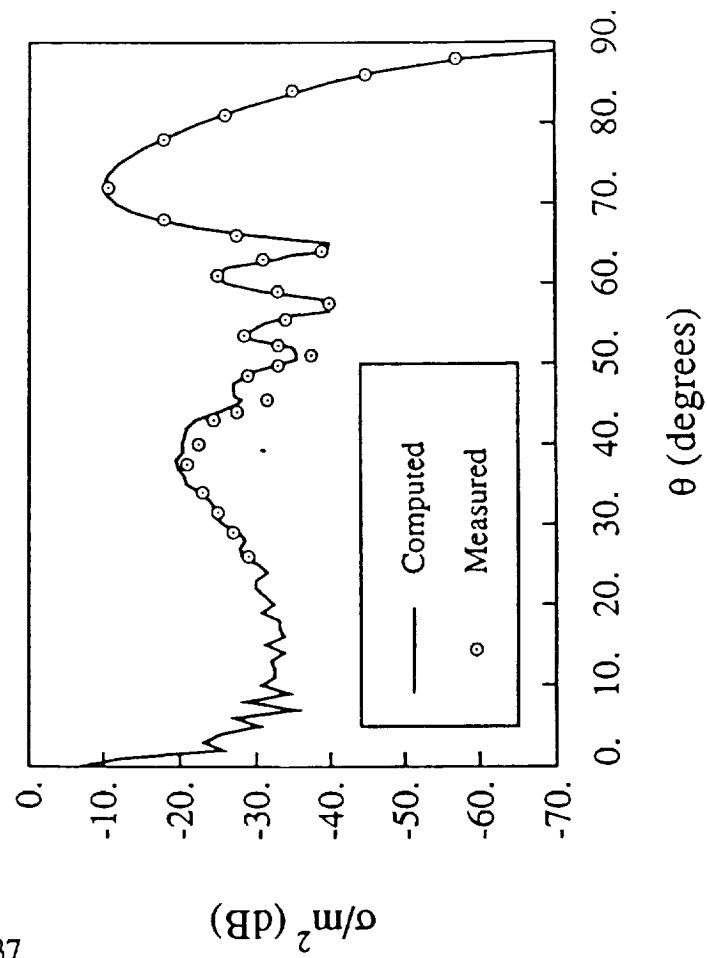

$\theta = 72^\circ, \phi = 0$

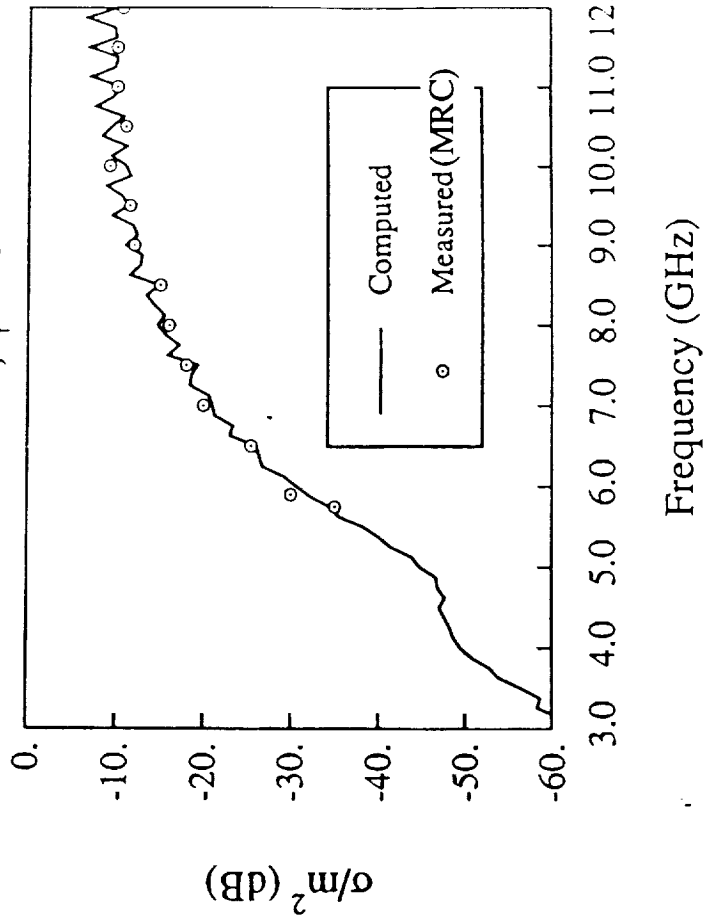

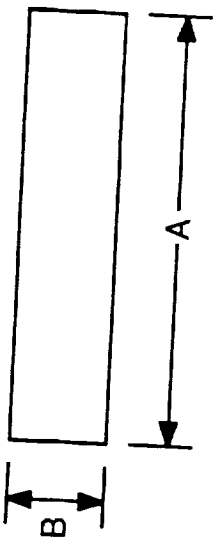

$A = 1.2\lambda$, $B = 0.25\lambda$, $t = 0.25\lambda$
 Filled with two dielectric layers

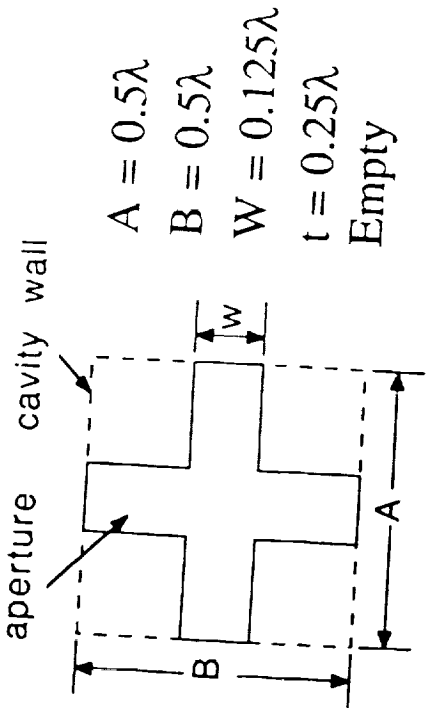
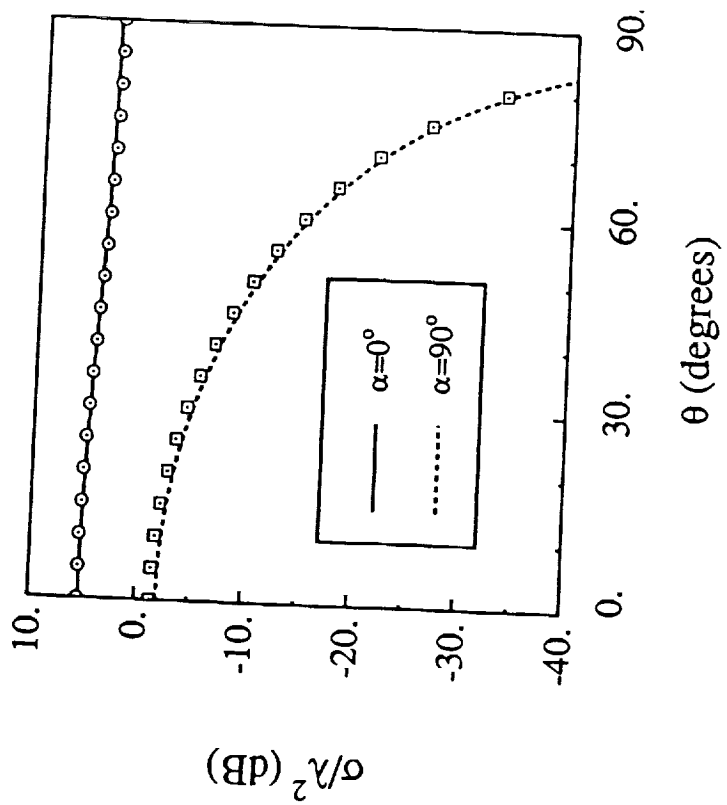

$A = 0.5\lambda$
 $B = 0.5\lambda$
 $W = 0.125\lambda$
 $t = 0.25\lambda$
 Empty

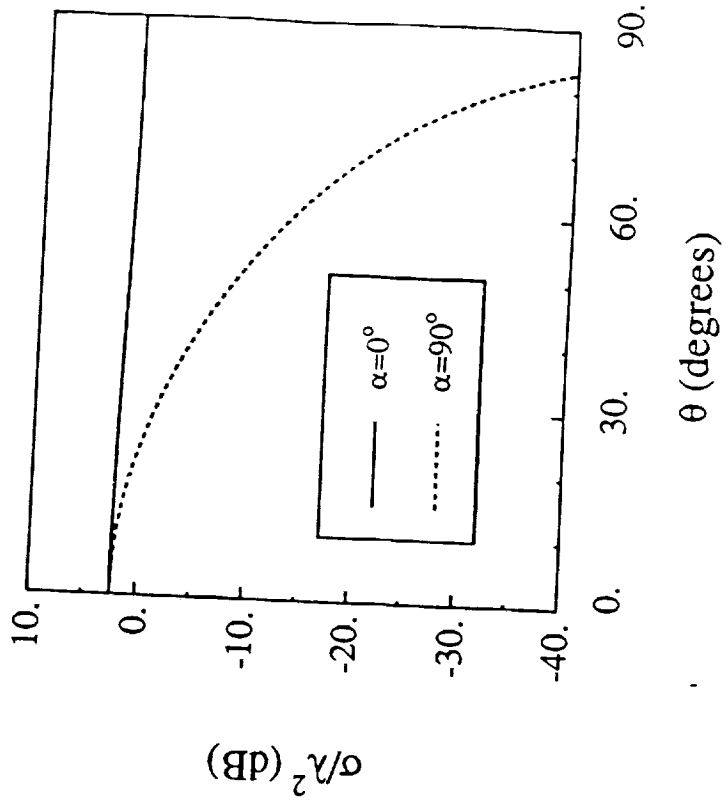

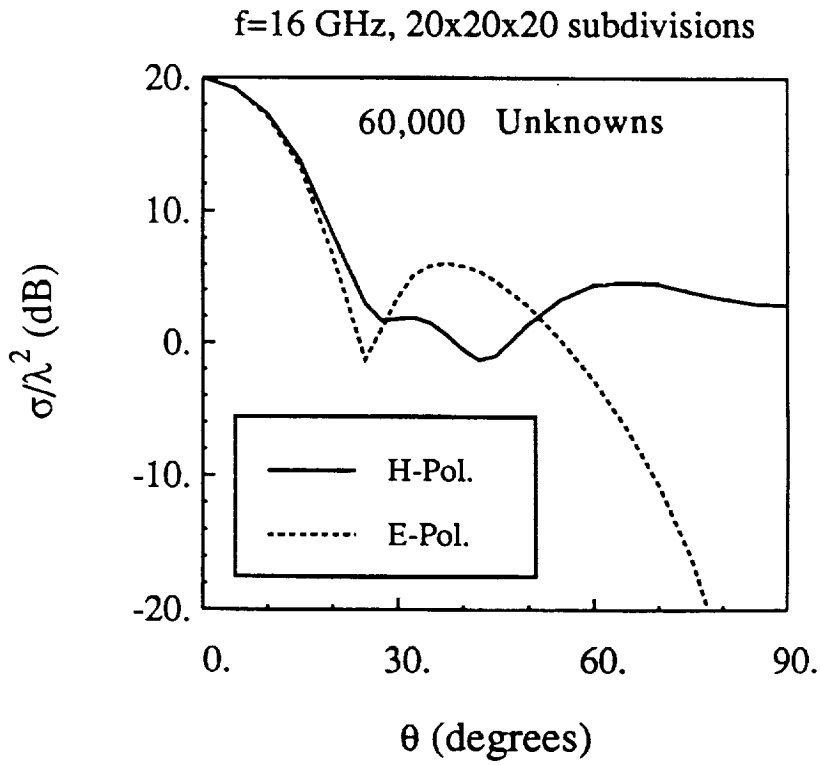
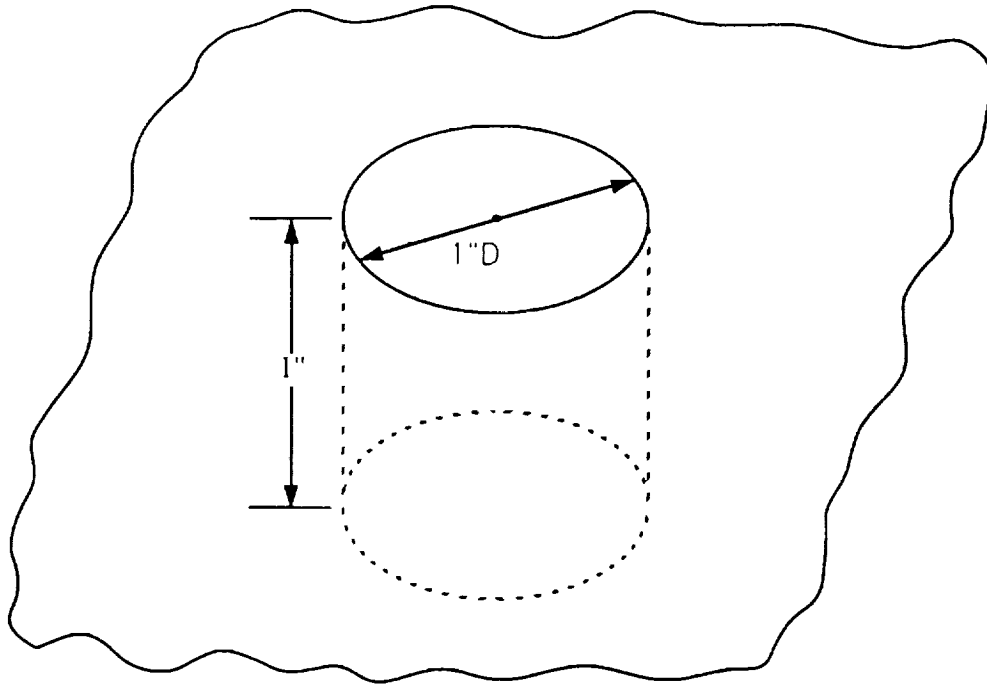

Finite Element Formulation

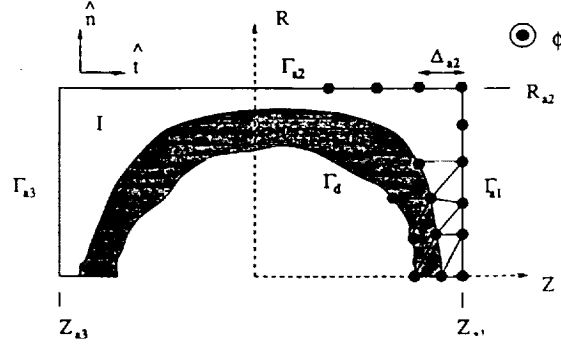

- Subdivide the region internal to Γ_a into finite elements
- Expand the fields over element e as

$$\psi_1^e = R \sum_{j=1}^3 e_{m\phi j}^e N_j^e(R, Z)$$

$$\psi_2^e = R \sum_{j=1}^3 h_{m\phi j}^e N_j^e(R, Z)$$

- Apply the method of weighted residuals to the CAP equations over the e th element

$$\iint_{S^e} R N_i^e(R, Z) \mathcal{R}_{s1}^e dS = 0$$

$$\iint_{S^e} R N_i^e(R, Z) \mathcal{R}_{s2}^e dS = 0$$

where

$$\mathcal{R}_{s1}^e = \nabla \cdot \left[f_m \left(\epsilon_r R \nabla \psi_1^e + m \hat{\phi} \times \nabla \psi_2^e \right) \right] + \frac{\epsilon_r \psi_1^e}{R}$$

$$\mathcal{R}_{s2}^e = \nabla \cdot \left[f_m \left(\mu_r R \nabla \psi_2^e - m \hat{\phi} \times \nabla \psi_1^e \right) \right] + \frac{\mu_r \psi_2^e}{R}$$

and N_i^e is the usual linear shape function.

FE-BE System Assembly

- The final finite element - boundary element system is

$$\begin{bmatrix} A_{aa} & A_{aI} & B_{aa} \\ A_{Ia} & A_{II} & 0 \\ L_{aa} & 0 & M_{aa} \end{bmatrix} \begin{bmatrix} u_{m\phi a} \\ u_{m\phi I} \\ u_{mt} \end{bmatrix} = \begin{bmatrix} 0 \\ 0 \\ u_{m\phi a}^{inc} \end{bmatrix}$$

where

$$L_{aa} = \begin{bmatrix} P & -Q \\ Q & P \end{bmatrix} \quad M_{aa} = \begin{bmatrix} -P^t & -Q^t \\ Q^t & -P^t \end{bmatrix}$$

and

$$\begin{aligned} P &= \frac{1}{2}[\frac{1}{2}I - P^\phi]C \\ Q &= \frac{1}{2}Q^\phi C + Q^{\phi'} D \end{aligned}$$

- A typical matrix element is

$$\left[Q_{22}^{\phi'} \right]_{ij} = \int_{Z_{j+1}}^{Z_j} j g_m^{(2)'}(R_2, R_2, Z_{i+\frac{1}{2}}, Z') Z' dZ'$$

- Solve the equation via the CG algorithm and use the FFT to compute some of the integrals

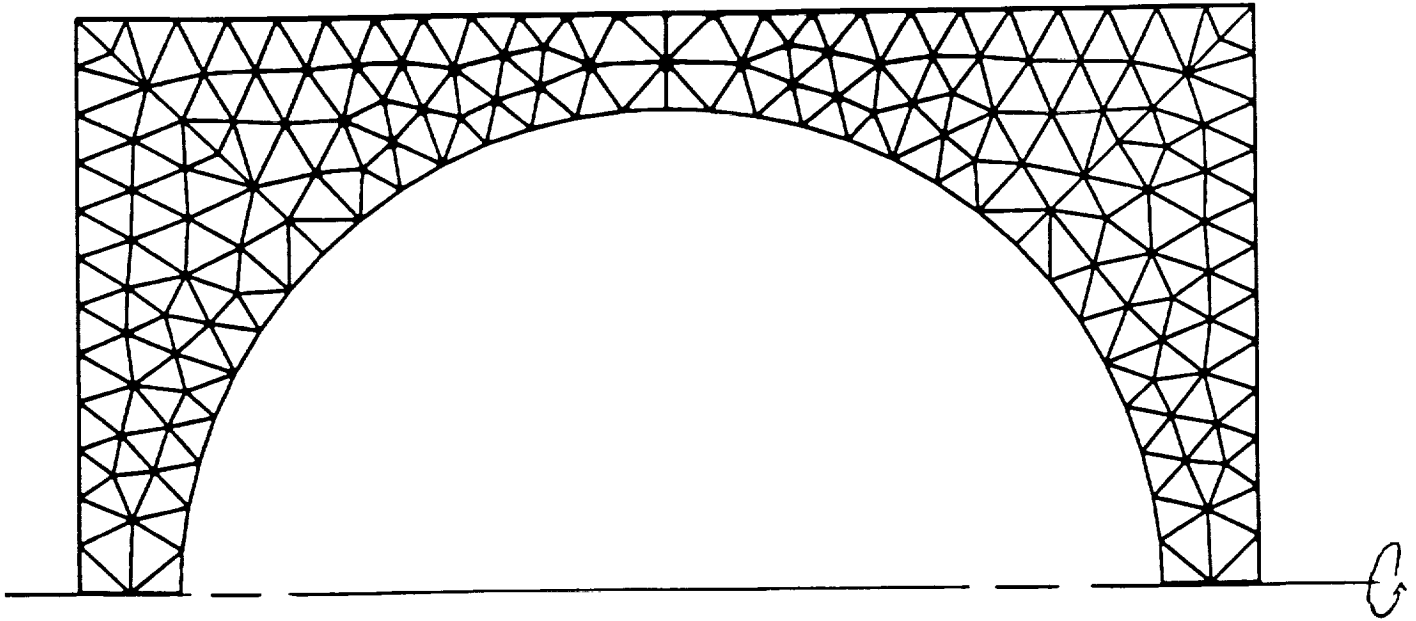

Conducting Sphere ($\rho=0.5\lambda$)

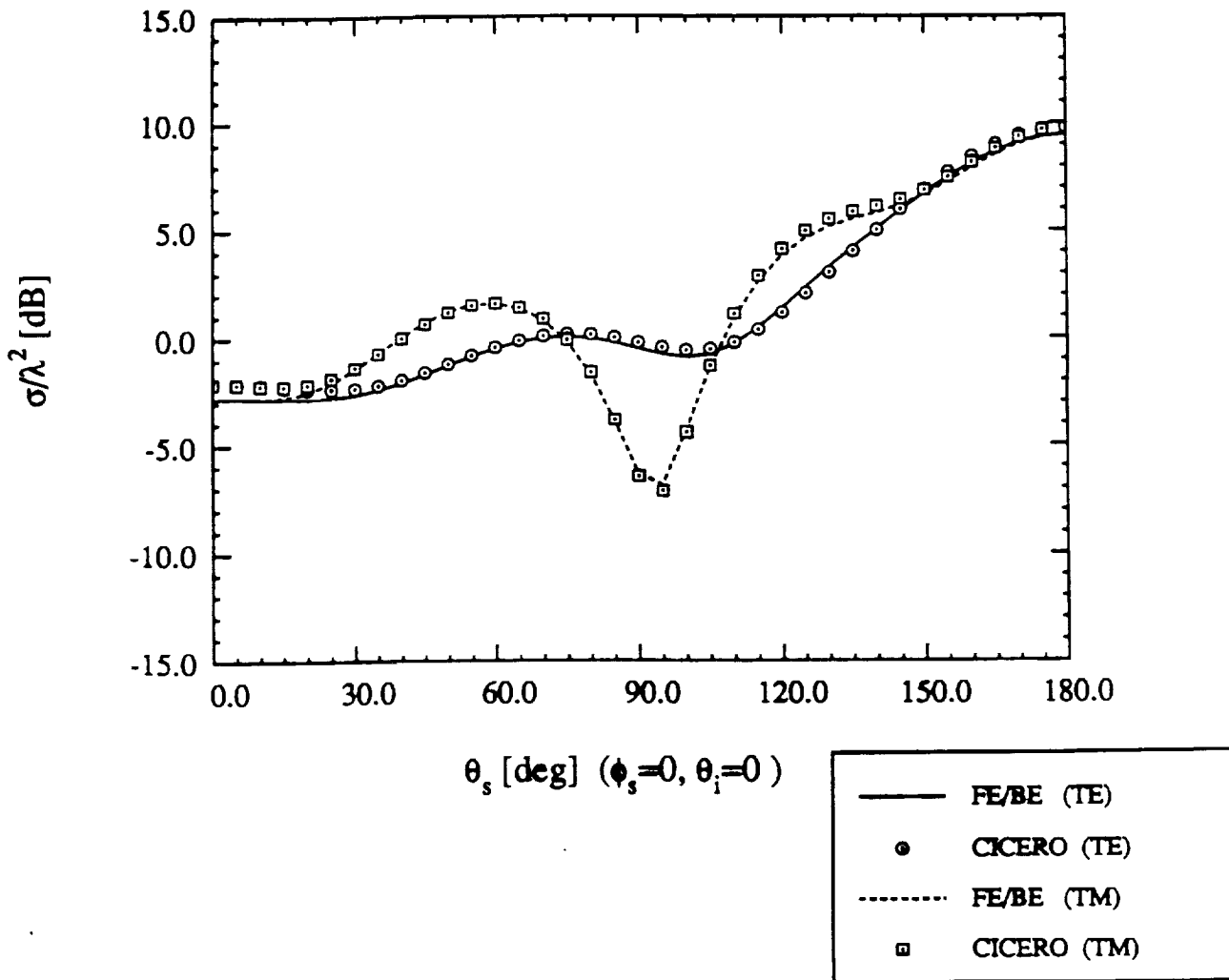

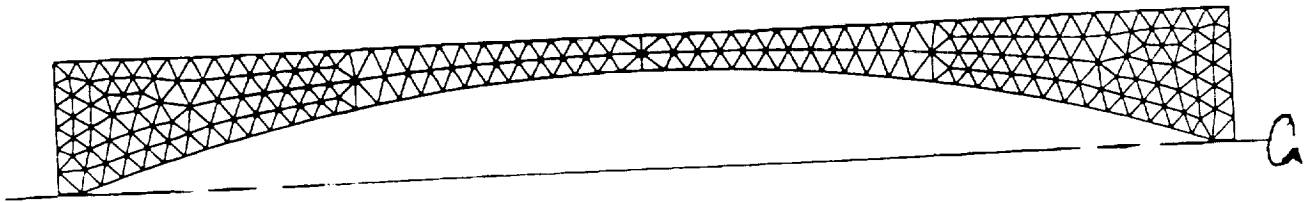

$\rho = .088\lambda, l = 1.0\lambda$ pc Ogive

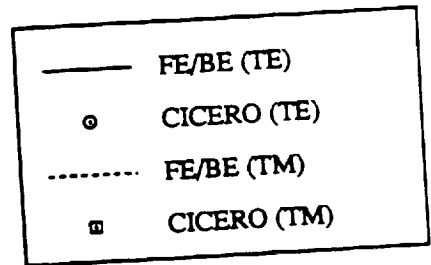
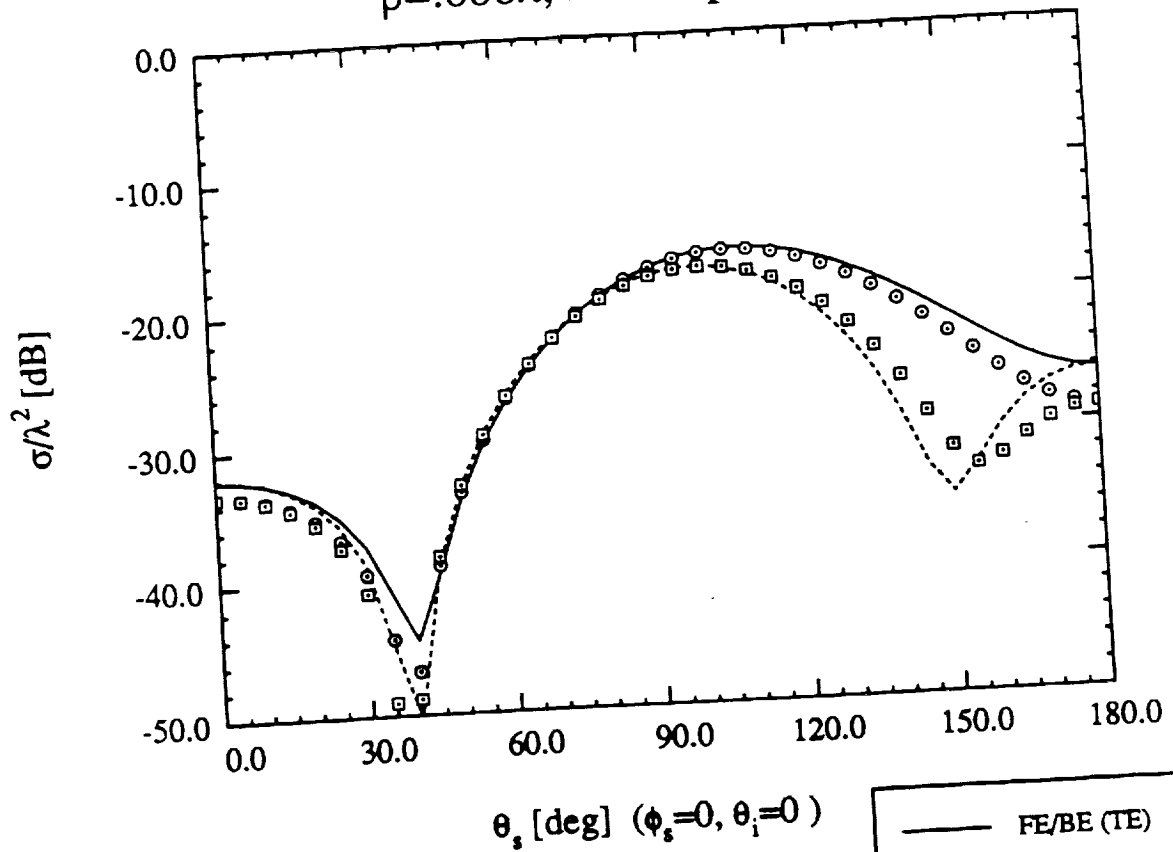

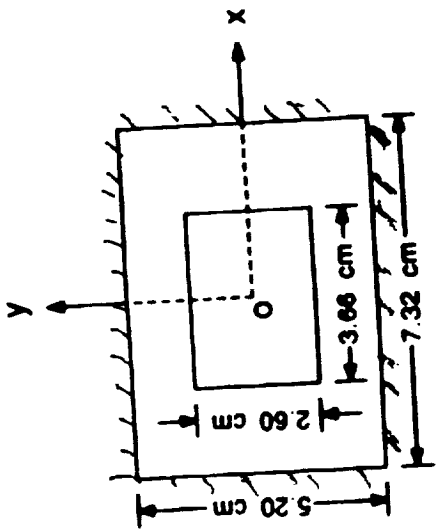
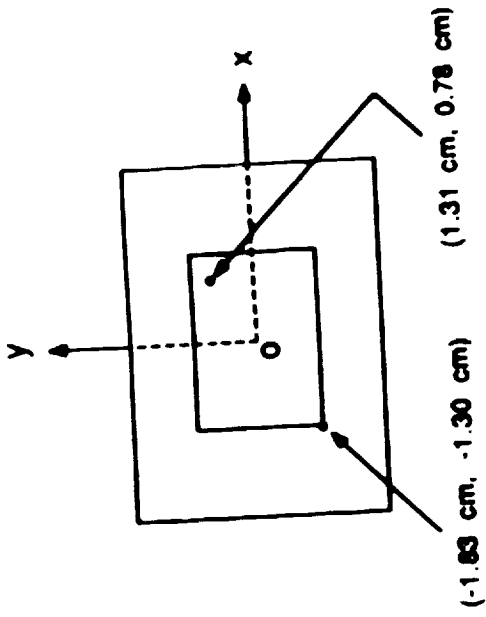

MEASURED (FORRAI + NEWMAN)

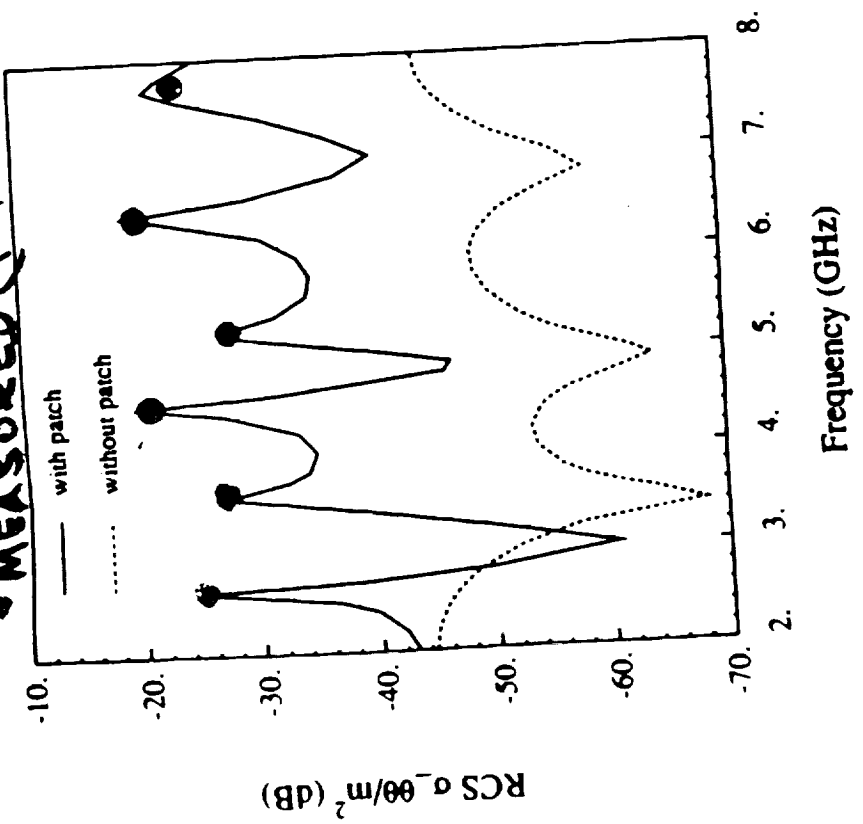
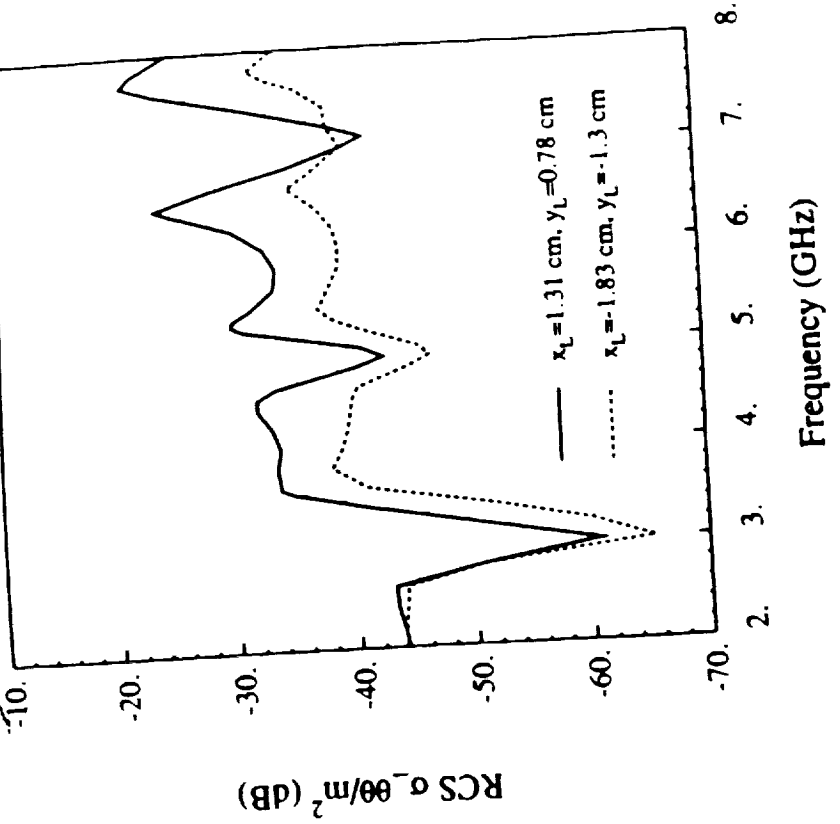

9 Element Array

$\phi_i = 45^\circ; \theta_i = 60^\circ$

EX-EY VECTOR PLOT

f = 2.62 GHz

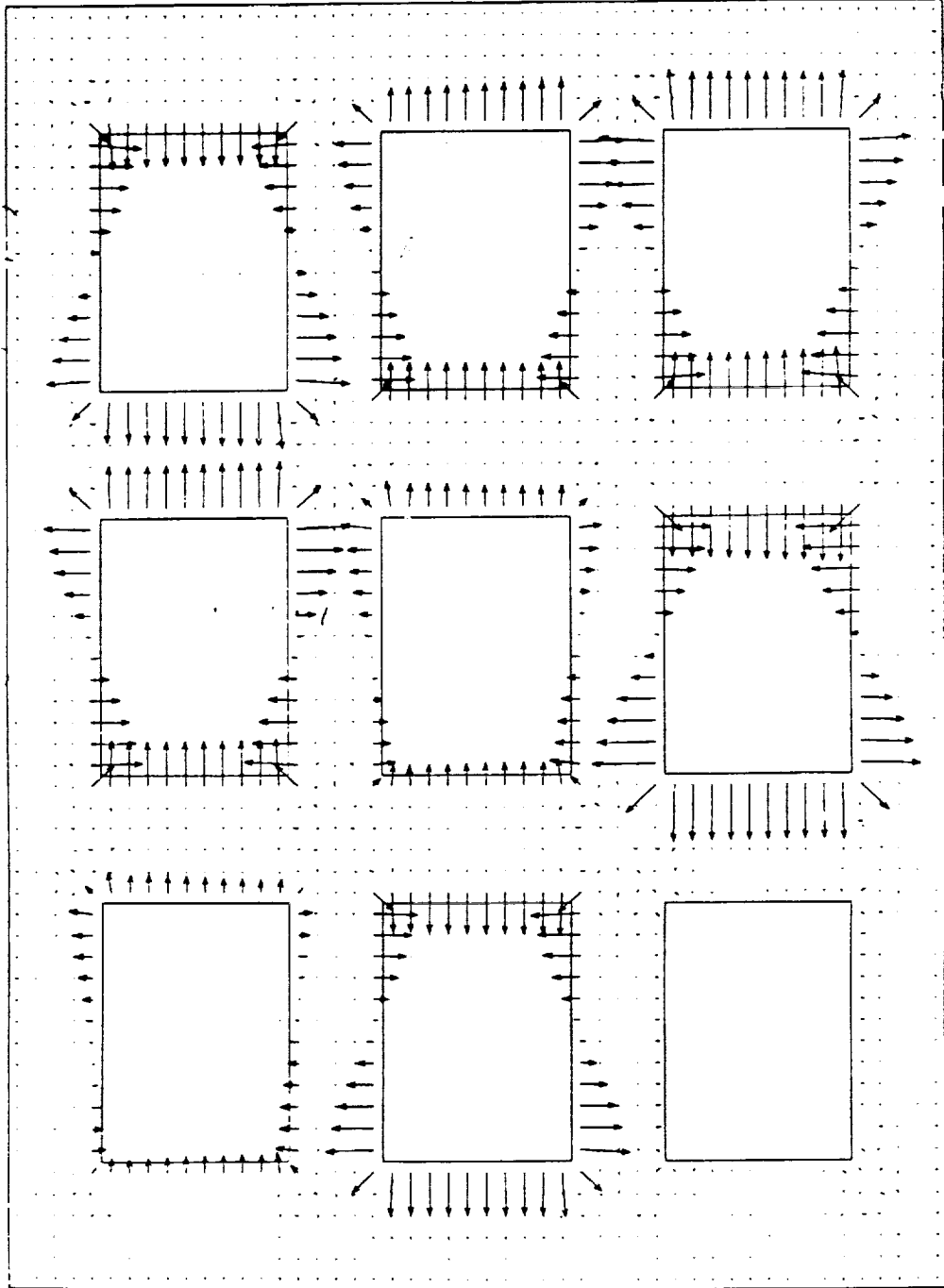

Total number of unknowns = 15,331 (3250 bricks) Number of non-zero field nodes = 6,423
CPU time per angle = 192 sec on YMP/832

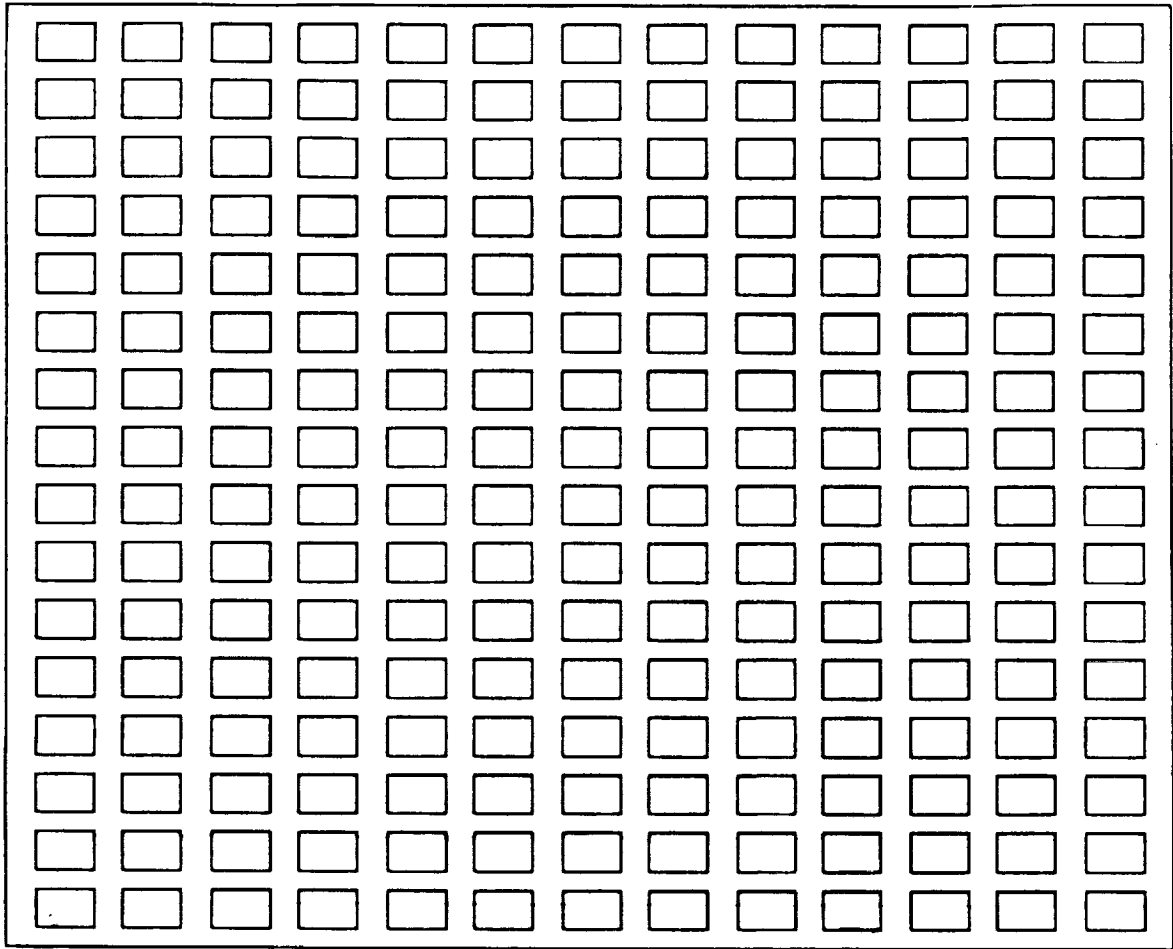

13 × 16 (=208) array

N=120,935

≈ 100 iterations

f=2.62 GHz

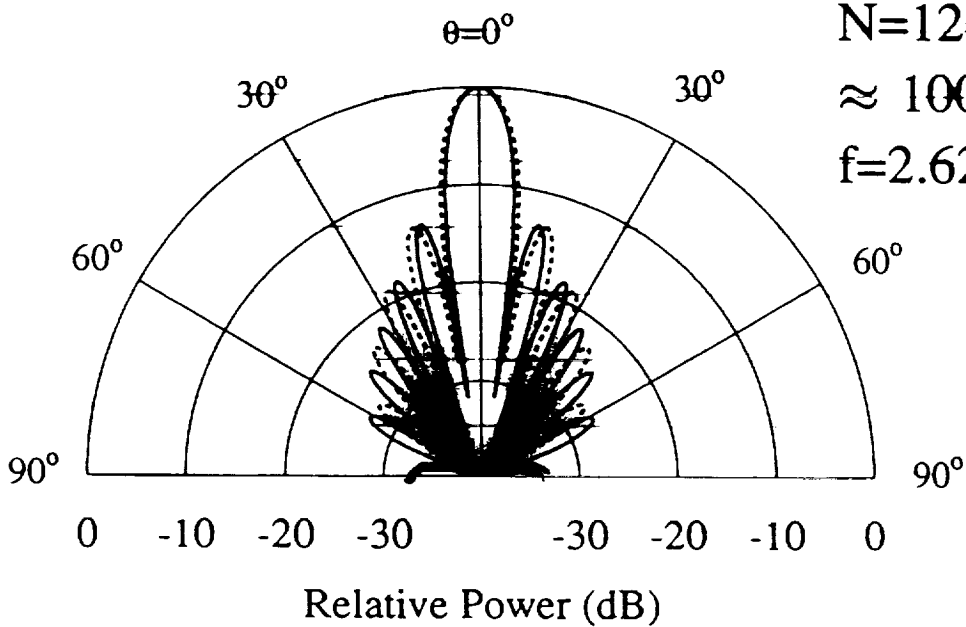

METHOD'S EFFICIENCY:

- (1) Expected to be very efficient in computation time (we have observed unusually fast convergences)
- (2) Less efficient for RCS vs angle computations
- (3) Very efficient in memory use:

Memory demand is approx.

$$5 N_t + 10 N_s \text{ complex}$$

$$5 N_t + 2 N_s \text{ integers}$$

Where

N_t = total number of unknowns and

N_s = number of aperture unknowns

METHOD'S VERSATILITY AND CAPABILITY:

- (1) Treats layered substrates and superstrates**
- (2) Treats microstrip patch antennas and slot antennas**
- (3) Models impedance loads and short-circuit pins**
- (4) Models probe feeds, microstrip line edge feeds and microstrip sandwich feeds**
- (5) Provides characterization of both scattering and radiation properties**
- (6) Has $O(n)$ memory demand and is capable of treating large geometries with tens of thousands unknowns**

APPENDIX A: List of Journal Articles

1. J.L. Volakis and T.B.A. Senior, "Application of a Class of Generalized Boundary Conditions to Scattering by a Metal-Backed Dielectric Half Plane," (invited paper) *Proceedings of the IEEE*, vol. 73, pp. 796-805, May 1989.
2. H.H. Syed and J.L. Volakis, "Multiple Diffractions Among Polygonal Impedance Cylinders," *IEEE Trans. on Antennas and Propagat.*, vol AP-37, pp. 664-672, May 1989.
3. M.A. Ricoy and J.L. Volakis, "E-polarization Diffraction by a Thick Metal-Dielectric Join," *J. of Electromagnetic Waves and Applications*, Vol. 3, No. 5, pp. 383-407, 1989.
4. K. Barkeshli and J.L. Volakis, "Improving the Convergence of the Conjugate Gradient FFT Method Using Subdomain Basis Functions," *IEEE Trans. on Antennas and Propagat.*, vol. AP-37, pp. 893-900, July 1989
5. K.Barkeshli and J.L. Volakis, "A Vector-Concurrent Application of a Conjugate Gradient FFT Algorithm to Electromagnetic Radiation and Scattering Problems," *IEEE Trans. on Magnetics*, Vol. 25, pp. 2892-2894, July 1986
6. J.-M. Jin and J.L. Volakis, "A New Technique for Characterizing Diffraction by Inhomogeneously Filled Slot of Arbitrary Cross Section in a Thick Conducting Plane," *IEE Electronic Letters*, Vol. 25, No. 17, pp. 1121-1122, 17th Aug. 1989.
7. J.L. Volakis and M.A. Ricoy, "H-polarization Diffraction by a Thick Metal-Dielectric Join," *IEEE Trans on Antennas and Propagat.*, Vol. AP-37, pp. 1453-1462, Nov. 1989.
8. T.B.A. Senior and J.L. Volakis, "Derivation and Application of a Class of Generalized Boundary Conditions," *IEEE Trans. on Antennas and Propagat.*, Vol. AP-37, PP. 1566-1572, Dec. 1989.
9. J.L. Volakis and J. Collins, "Electromagnetic Scattering From a Resistive Half-Plane on a Dielectric Interface," *Wave Motion*, Vol. 12, pp. 81-96, 1990.
10. K. Barkeshli and J.L. Volakis, "On the Implementation and Accuracy of the Conjugate Gradient Fourier Transform Method," *IEEE Transactions Antennas and Propagation Magazine*, Vol. 32, No.2, pp. 20-26, April 1990.
11. J.-M. Jin and J.L. Volakis, "TM Scattering by an Inhomogeneously Filled Aperture in a Thick Ground Plane," *IEE Proceedings, Part H*. Vol. 137, No. 3, pp. 153-159, June 1990.
12. J.L. Volakis and P.B. Katehi, "Research in Computational Electromagnetics at the University of Michigan," *IEEE Transactions Antennas and Propagation Magazine.*, Vol. 32, pp. 16- 30, June 1990.

13. J.-M. Jin and J.L. Volakis, "TE Scattering by an Inhomogeneously Filled Aperture in a Thick Conducting Plane," *IEEE Trans. Antennas and Propagat.*, Vol AP-38, pp. 1280-1286, August 1990.
14. K. Barkeshli and J.L. Volakis, "TE Scattering by a Two-Dimensional Groove in a Ground Plane Using Higher Order Boundary Conditions," *IEEE Trans. Antennas and Propagat.*, pp.1421-1428, October 1990.
15. M.A. Ricoy and J.L. Volakis, "Derivation of Generalized Transition/Boundary Conditions for Planar Multiple Layer Structures," *Radio Sci.*, Vol. 25, pp. 391-405, July-Aug. 1990.
16. J.D. Collins and J.L. Volakis and J.M. Jin, "A Finite Element-Boundary Integral Formulation for Solution via CGFFT of Two-Dimensional Scattering Problems," *IEEE Trans. Antennas and Propagat.*, Vol. AP-38, pp. 1852-1858, November 1990.
17. J.L. Volakis and H.H. Syed, "Application of Higher Order Boundary Conditions to Scattering by Multi-layer Coated Cylinders," *J. of Electromagnetic Waves and Applications.*, Vol. 4, No. 12, pp. 1157-1180, 1990
18. J. D. Collins, J.-M. Jin and J.L. Volakis, "A Combined Finite Element-Boundary Element Formulation for Solution of Two-Dimensional Problems via CGFFT," *Electromagnetics*, Vol 10, pp. 423-437, 1990.
19. J.M. Jin and J.L. Volakis, " A Finite Element-Boundary Integral Formulation for Scattering by Three-Dimensional Cavity-Backed Apertures," *IEEE Trans. Antennas and Propagation.*, Vol. AP-39, pp. January 1991.
20. M.A. Ricoy and J. L. Volakis, "Diffraction by a Multilayered Slab Recessed in a Ground Plane via a Generalized Impedance Boundary Condition," *Radio Science*, March-April, 1991.
21. K. Barkeshli and J.L. Volakis, " Electromagnetic Scattering by an Aperture Formed by Rectangular Cavity Recessed in a Ground Plane," accepted in *J. Electromagnetic Waves and Applications*, 1991
22. J.M. Jin and J.L. Volakis, "Electromagnetic Scattering by and Transmission through a Three-Dimensional Slot in a Thick Conducting Plane," *IEEE Trans. Antennas and Propagat.*, Vol. AP-39, April 1991
23. H.H. Syed and J.L. Volakis, "An Approximate Diffraction Coefficient for an Impedance Wedge at Skew Incidence," submitted to *IEEE Trans. Antennas and Propagat.*
24. J.M. Jin, J.L. Volakis and J.D. Collins, "A Finite Element-Boundary Element Method for Scattering by Two and Three Dimensional Structures," submitted to *IEEE Antennas and Propagat. Magazine*.
25. T.B.A. Senior and J.L. Volakis "Generalized Impedance Boundary Conditions in Scattering," accepted in *Proceedings of the IEEE*.
26. M.A. Ricoy and J.L. Volakis, "Diffraction by a Symmetric Material Junction, Part I: General Solution," submitted to *IEEE Trans. Antennas and Propagat.*

27. M.A. Ricoy and J.L. Volakis, "Diffraction by a Symmetric Material Junction, Part II: Resolution of Non-Uniqueness Associated with Higher Order Boundary Conditions," submitted to *IEEE Trans. Antennas and Propagat.*
28. H.H. Syed and J.L. Volakis, "High Frequency Scattering by a Smooth Coated Cylinder Simulated with Generalized Impedance Boundary Conditions," accepted in *Radio Science*
29. J.M. Jin and J. L. Volakis, "Scattering and Radiation From Microstrip Patch Antennas and Arrays Residing in a Cavity," submitted to *IEEE Trans. Antennas and Propagat.*
30. J.M. Jin and J.L. Volakis, "Scattering by a Finite Frequency Selective Surface," submitted to the *IEEE Trans. Antennas and Propagat.*
31. J.M. Jin and J.L. Volakis, "A Biconjugate Gradient FFT Solution for Scattering by Planar Plates," submitted to *Electromagnetics*
32. J.M. Jin, J. L. Volakis, C.L. Yu and A. Woo, "Modeling of Resistive Sheets in the Context of the Finite Element Solutions," submitted to *IEEE Trans. Antennas and Propagat.*
33. A. Chatterjee, J.M. Jin and J.L. Volakis, "Computation of Cavity Resonances Using Edge-Based Finite Elements," submitted to *IEEE Trans. Microwave Theory and Techn.*
34. J.M. Jin and J.L. Volakis, "A Fictitious Absorber For Truncating Finite Element Meshes in Scattering," submitted to *IEE Proceedings, Part H.*

Appendix B: Reports List

1. J.L. Volakis, T.B.A. Senior and J.-M. Jin, "Derivation and Application of a Class of Generalized Impedance Boundary Conditions - II," University of Michigan Radiation Laboratory, Technical Report 025921-1-T, February 1989, 47 pp.
2. K. Barkeshli and J.L. Volakis, "Scattering by a Two-Dimensional Groove in a Ground Plane," University of Michigan Radiation Laboratory, Technical Report 025921-2-T, February 1989, 31 pp.
3. J.L. Volakis, "Semi-Annual Progress Report for NASA Grant NAG-2-541," The University of Michigan Radiation Laboratory, Technical Report 025921-3-T, 45 pp.
4. H.H. Syed and J.L. Volakis, "An Approximate Skew Incidence Diffraction Coefficient for an Impedance Wedge," University of Michigan Radiation Laboratory, Technical Report 025921-4-T, September 1989, 31 pp.
5. M.A. Ricoy and J.L. Volakis, "Derivation of Generalized Transition/Boundary Conditions for Planar Multiple Layer Structures," University of Michigan Radiation Laboratory, Technical Report 025921-5-T, September 1989, 36 pp.
6. J.D. Collins and J.L. Volakis, "A Combined Finite Element and Boundary Integral Formulation for Solution via CGFFT of Two-Dimensional Scattering Problems," University of Michigan Radiation Laboratory, Technical Report 025921-6-T, September 1989, 73 pp.
7. J.L. Volakis, "Semi-Annual Report for NASA Grant NAG 2-541," University of Michigan Radiation Laboratory, Report 025921-7-T, September 1989, 46 pp.
8. M. A. Ricoy and J. L. Volakis, "Diffraction by a Multilayered Slab Recessed in a Ground Plane via the Generalized Impedance Boundary Conditions," University of Michigan Radiation Laboratory, Technical Report 025921-8-T, Dec. 1989, 34 pp.
9. H.H. Syed and J.L. Volakis, "An Asymptotic Analysis of the Plane Wave Scattering by a Smooth Convex Impedance Cylinder," University of Michigan Radiation Laboratory, Technical Report 025921-9-T, Jan. 1990. 31 pp.
10. J.M Jin and J.L. Volakis, "A Finite Element-Boundary Integral Formulation For Scattering by Three-Dimensional Cavity Backed Apertures," University of Michigan Radiation Laboratory Technical Report 025921-10-T, February 1990. 28 pp.
11. J. D. Collins J.M. Jin and J.L. Volakis, "A Combined Finite Element-Boundary element Formulation for Solution of Two Dimensional Problems via CGFFT," University of Michigan Radiation Laboratory Technical Report 025921-11-T, February 1990. 45 pp.
12. J. L. Volakis, "Semi-Annual Report for NASA Grant NAG 2-541," University of Michigan Radiation Laboratory Report 025921-12-T, February 1990, 60 pp.

13. J. L. Volakis, "Semi-Annual Report for NASA Grant NAG 2-541," University of Michigan Radiation Laboratory Report 025921-13-T, September 1990, 56 pp.
14. M.A. Ricoy and J.L. Volakis, " Electromagnetic Scattering from Two-Dimensional Thick Material Junctions," University of Michigan Radiation Laboratory 025921-14-T, August 1990; 166pp.
15. C. Hua, "User's Manual for AUTOMESH-2D: A Program of Automatic Mesh Generation for Two-Dimensional Scattering Analysis by the Finite Element Method," Univeristy of Michigan Radiation Laboratory Report 025921-15-T, August 1990, 38 pp.
16. J. Zapp, "Examples of Finite Mesh Generation Using SDRC IDEAS," University of Michigan Radiation Laboratory Report 025-921-16-T, August 1990, 38 pp.
17. H.H.Syed and J.L. Volakis, "High Frequency Scattering by a Smooth Coated Cylinder Simulated with Generalized Impedance Boundary Conditions," University of Michigan Radiation Laboratory Report 025921-17-T, January 1991. 32pp.
18. J.D. Collins and J.L. Volakis, " A Combined Finite Element-Boundary Element Formulation for Solution of Axially Symmetric Bodies," University of Michigan Radiation Laboratory Report 025921-18-T, January 1991. 64pp.
19. J.L. Volakis, "Semi-Annual Report for NASA Grant NAG 2-541," University of Michigan Radiation Laboratory Technical Report 025921-19-T, February 1991, 45 pp.
20. J.M. Jin, J.L. Volakis and J.D. Collins, "A finite Element -Boundary Integral Method for Scattering and Radiation by Two and Three Dimensional Structures," University of Michigan Radiation Laboratory Technical Report 025921-20-T, 36pp.
21. K. Barkeshli and J. L. Volakis, "Applications of the conjugate gradient FFT method in scattering and radiation including simulations with impedance boundary conditions," University of Michigan Radiation Laboratory Report 025912-21-T, May 1991.
22. A. Chatterjee, J.M. Jin and J.L. Volakis, "Use of edge-based finite elements for solving three dimensional scattering problems," University of Michigan Radiation Laboratory Report 025921-22-T, August 1991.

Abstracts of technical reports

DERIVATION AND APPLICATION OF A CLASS OF GENERALIZED BOUNDARY CONDITIONS - II

**J. L. Volakis, T. B. A. Senior, and J.-M. Jin
The Radiation Laboratory
Department of Electrical Engineering and Computer Science
The University of Michigan
Ann Arbor, MI 48109-2122**

Abstract

Boundary conditions involving higher order derivatives are presented for simulating surfaces whose reflection coefficients are known analytically, numerically or experimentally. Procedures for determining the coefficients of the derivatives are discussed, along with the effect of displacing the surface where the boundary conditions are applied. Provided the coefficients satisfy a duality relation, equivalent forms of the boundary conditions involving tangential field components are deduced, and these provide the natural extension to non-planar surfaces. As an illustration, the simulation of metal-backed uniform and three layer dielectric coatings is given. It is shown that fourth order conditions are capable of providing an accurate simulation for the uniform coating at least a quarter of a wavelength in thickness. Provided, though, some compromise in accuracy is acceptable, it is also shown that a third order condition may be sufficient for practical purposes when simulating uniform coatings.

Scattering by a Two Dimensional Groove in a Ground Plane

Kasra Barkeshli and John L. Volakis

Abstract

Higher order boundary conditions involve derivatives of the fields beyond the first and were recently shown to be more effective than traditional first order conditions in modeling dielectric coatings and layers. In this report an application of a third order generalized boundary condition to scattering by a filled rectangular groove is presented. Deficiencies of such higher order boundary conditions are addressed and a correction is proposed for the present case. As part of the process of examining and improving the accuracy of the proposed generalized boundary conditions, an exact solution is developed and a comparison is provided with a solution based on the standard impedance boundary condition.

Preface

This semi-annual report describes our progress during the period from September 1988 to February 1989. There are four separate tasks described in this report. Although, some of these tasks are interdependent, their reports should be read independently. That is, figure and reference numbering is consecutive only within the description of a given task. As can be expected, the progress report on each task is brief. The reader is expected to refer to the detailed reports or papers referenced in the progress reports.

An Approximate Skew Incidence Diffraction Coefficient for an Impedance Wedge

Hasnain H. Syed and John L. Volakis
Radiation Laboratory
Department of Electrical Engineering and Computer Science
The University of Michigan
Ann Arbor, MI 48109-2122

Abstract

An approximate diffraction coefficient is presented for an impedance wedge at skew incidence. This is based on suitable modifications of the available skew incidence solution for an impedance half plane. The derived diffraction coefficient reduces to the known ones for an impedance wedge at normal incidence, a perfectly conducting wedge at skew incidence as well as an impedance half plane at skew incidence. An additional crucial requirement that the total field remains continuous at the reflection and shadow boundary is also imposed. Using the derived approximate diffraction coefficient a first order solution is obtained for the scattering by a polygonal impedance cylinder at skew incidence. This is then compared with numerical data which validate the accuracy of the presented dyadic coefficient.

Derivation of Generalized Transition/Boundary Conditions for Planar Multiple Layer Structures ¹

September, 1989

M. A. Ricoy and J. L. Volakis

Radiation Laboratory
Department of Electrical Engineering and Computer Science
The University of Michigan
Ann Arbor, Michigan 48109-2122

Abstract-Infinite order generalized impedance boundary conditions (GIBCs) and generalized sheet transition conditions (GSTCs) for planar multilayer configurations are developed via the Taylor series expansion method. The conditions are derived in a matrix product form where each matrix corresponds to a specific layer. An overall composite boundary/transition condition is obtained by making finite order approximations to the elements of each matrix for the cases of "low contrast" and "high contrast" material layers. The accuracy of the truncated boundary conditions is examined by comparing their implied reflection and transmission coefficients with the corresponding exact coefficients. Design curves are also given which relate the maximum order of the conditions required to simulate a coating or layer of specific thickness and contrast. Expressions are then derived for the reflection and transmission coefficients of the GIBC/GSTC sheets and these are compared to exact coefficients to demonstrate the validity of the derived GIBCs/GSTCs.

¹This work was supported in part by the NASA Ames Research Center under Grant NAG 2-541.

A Combined Finite Element-Boundary Element Formulation
for Solution via CGFFT of 2-Dimensional Scattering Problems

J.D. Collins and J.L. Volakis

Radiation Laboratory
Department of Electrical Engineering and Computer Science
The University of Michigan
Ann Arbor, MI 48109-2122

Abstract

A new technique is presented for computing the scattering by two-dimensional structures of arbitrary composition. The proposed solution approach combines the usual finite element method with the boundary integral equation to formulate a discrete system. This subsequently solved via the conjugate gradient (CG) algorithm. A particular characteristic of the method is the use of rectangular boundaries to enclose the scatterer. Several of the resulting boundary integrals are therefore convolutions and may be evaluated via the fast Fourier transform (FFT) in the implementation of the CG algorithm. The solution approach offers the principle advantage of having $O(N)$ memory demand and employs a one-dimensional FFT versus a two-dimensional FFT as required with a traditional implementation of the CGFFT algorithm. The speed of the proposed solution method is compared with that of the traditional CGFFT algorithm, and results for rectangular bodies are given and shown to be in excellent agreement with the moment method.

Preface

This semi-annual report describes our progress during the period from February 1989 to September 1989. In all, six technical reports, seven journal articles and eight conference papers have been completed since the beginning of this grant one year ago. These are referenced at the end of each task described in the reprint.

There are four tasks described in this report. Each should be read independently. That is, figure and reference numbering is consecutive only within the description of the task. As can be expected, the progress reports are very brief and the reader should refer to the referenced technical reports for detailed coverage.

Diffraction by a Multilayer Slab Recessed in a Ground Plane via Generalized Impedance Boundary Conditions ¹

December, 1989

M. A. Ricoy and J. L. Volakis

Radiation Laboratory

Department of Electrical Engineering and Computer Science

The University of Michigan

Ann Arbor, Michigan 48109-2122

Abstract-The diffraction problem associated with a multilayer material slab recessed in a perfectly conducting ground plane is formulated and solved via the Generalized Scattering Matrix Formulation (GSMF) in conjunction with the dual integral equation approach. The multilayer slab is replaced by a surface obeying a generalized impedance boundary condition (GIBC) to facilitate the computation of the pertinent Wiener Hopf split functions and their zeros. Both E_z and H_z polarizations are considered and a number of scattering patterns are presented, some of which are compared to exact results available for a homogeneous recessed slab.

An Asymptotic Analysis of the Plane Wave Scattering by a Smooth Convex Impedance Cylinder

Hasnain H. Syed and John L. Volakis
Radiation Laboratory
Department of Electrical Engineering and Computer Science
The University of Michigan
Ann Arbor, MI 48109-2122

Abstract

A rigorous UTD (Uniform Geometrical Theory of Diffraction) analysis of the diffraction by a smooth convex impedance cylinder is presented. The analysis parallels the one employed for the perfectly conducting cylinder. Ray solutions are obtained which remain valid in the transition region and uniformly reduce to those in the lit and the shadow regions. In addition, a ray solution is presented when the observation point is in the close vicinity of the cylinder. The resulting transition region expressions are in terms of Fock-type integrals which are evaluated using a numerical scheme based on Fourier quadrature.

A FINITE ELEMENT-BOUNDARY INTEGRAL FORMULATION
FOR SCATTERING BY THREE-DIMENSIONAL
CAVITY-BACKED APERTURES

Jian-Ming Jin and John L. Volakis

Radiation Laboratory

Department of Electrical Engineering and Computer Science

The University of Michigan

Ann Arbor, Michigan 48109

ABSTRACT

A new numerical technique is proposed for the electromagnetic characterization of the scattering by a three-dimensional cavity-backed aperture in an infinite ground plane. The technique combines the finite element and boundary integral methods to formulate a system of equations for the solution of the aperture fields and those inside the cavity. Specifically, the finite element method is employed to formulate the fields in the cavity region and the boundary integral approach is used in conjunction with the equivalence principle to represent the fields above the ground plane. Unlike traditional approaches, the proposed technique does not require knowledge of the cavity's Green's function and is, therefore, applicable to arbitrary shape depressions and material fillings. Furthermore, the proposed formulation leads to a system having a partly full and partly sparse as well as symmetric and banded matrix which can be solved efficiently using special algorithms.

Abstract

A new method for the computation of electromagnetic scattering from arbitrary two-dimensional bodies is presented. The method combines the finite element and boundary element methods leading to a system for solution via the Conjugate Gradient FFT algorithm. Two forms of boundaries aimed at reducing the storage requirement of the boundary integral are investigated. It is shown that the boundary integral becomes convolutional when a circular enclosure is chosen, resulting in reduced storage requirement when the system is solved via the Conjugate Gradient FFT method. The same holds for the ogival enclosure, except that some of the boundary integrals are not convolutional and must be carefully treated to maintain the $O(N)$ memory requirement. Results for several circular and ogival structures are presented and shown to be in excellent agreement with those obtained by traditional methods.

Preface

This semi-annual report describes our progress during the period from September 1989 to February 1990. Several technical reports and papers have been written and these are listed at the end of each task.

There are four tasks described in this report. Each should be read independently. That is, figure and reference numbering is consecutive only within the description of the task. As can be expected, the progress reports are very brief and the reader should refer to the referenced technical reports for detailed coverage.

Preface

This semi-annual report describes our progress during the period from February 1990 to September 1990. Several technical reports and papers have been written and these are listed at the end of each task.

There are two tasks described in this report. Each should be read independently. That is, figure and reference numbering is consecutive only within the description of the task. As can be expected, the progress reports are very brief and the reader should refer to the referenced technical reports for detailed coverage. A total of sixteen technical reports have already been submitted and two more are currently being prepared. Also, more than 18 publications to refereed journals and more than 17 conference papers have resulted from this sponsored research.

Electromagnetic Scattering From Two-Dimensional Thick Material Junctions

August, 1990

M. A. Ricoy and J. L. Volakis

Radiation Laboratory

Department of Electrical Engineering and Computer Science

The University of Michigan

Ann Arbor, Michigan 48109-2122

Abstract-Because material junctions are commonplace on structures whose radar cross section is of interest, it is essential that their scattering properties be adequately characterized. The standard impedance boundary condition (SIBC) has been employed in the past along with function theoretic techniques to develop simple scattering models of material junctions with thin and/or high loss slabs. To extend these models to more general slabs, generalized impedance boundary conditions (GIBCs) and generalized sheet transition conditions (GSTCs) have been proposed. Unfortunately, the solutions obtained with these are usually non-unique in the form of unknown constants, and although the constants have been resolved for a few special cases, previous efforts were unable to determine them in the general case.

This report examines the problem of the plane wave diffraction by an arbitrary symmetric two-dimensional junction, where Generalized Impedance Boundary Conditions (GIBCs) and Generalized Sheet Transition Conditions (GSTCs) are employed to simulate the slabs. In chapter 2, GIBCs and GSTCs are constructed for multilayer planar slabs of arbitrary thickness and the resulting GIBC/GSTC reflection coefficients are compared with exact counterparts to evaluate the GIBCs/GSTCs. In chapter 3 the plane wave diffraction by a multilayer material slab recessed in a perfectly conducting ground plane is formulated and solved via the Generalized Scattering Matrix Formulation (GSMF) in conjunction with the dual integral equation approach. Various scattering patterns are computed and validated with exact results where possible.

In chapter 4, the diffraction by a material discontinuity in a thick dielectric/ferrite slab is considered by modelling the constituent slabs with GSTCs. A non-unique solution in terms of unknown constants is obtained, and these constants are evaluated for the recessed slab geometry of chapter 3 by comparison with the solution obtained therein. Several other simplified cases are also presented and discussed. In chapter 5 an eigenfunction expansion method is introduced to determine the unknown solution constants in the general case. This procedure is applied to the solution of chapter 4, and scattering patterns are presented for various slab junctions and compared with alternative results where possible. Chapter six presents a short summary of this report and some recommendations for future work.

Table of Contents

	Page
Introduction	1
Running AUTOMESH-2D	5
Example Problems	7
Appendix I: Results for Example	10
Appendix II: Results for Example 2	23
Appendix III: Results for Example 3	28

Table of Contents

	Page
Introduction to IDEAS	1
Pre/Post Processing	2
Mesh Generation	4
Getting Started with IDEAS	6
Mesh Generation 2-D Example	
Material Properties	
Mesh Generation 3-D Example	
Appendix A: Widely Used Global Commands	22
Appendix B: Examples of 2-D and 3-D Meshes	44

High Frequency Scattering by a Smooth Coated Cylinder Simulated with Generalized Impedance Boundary Conditions

Hasnain H. Syed and John L. Volakis

Radiation Laboratory
Department of Electrical Engineering and Computer Science
The University of Michigan
Ann Arbor, Michigan 48109-2122

Abstract

Rigorous UTD (Uniform Geometrical Theory of Diffraction) diffraction coefficients are presented for a coated convex cylinder simulated with generalized impedance boundary conditions. In particular, ray solutions are obtained which remain valid in the transition region and reduce uniformly to those in the deep lit and shadow regions. These involve new transition functions in place of the usual Fock-type integrals, characteristic to the impedance cylinder. A uniform asymptotic solution is also presented for observations in the close vicinity of the cylinder. As usual, the diffraction coefficients for the convex cylinder are obtained via a generalization of the corresponding ones for the circular cylinder.

Abstract

A new method is presented for the computation of electromagnetic scattering from axially symmetric bodies. To allow the simulation of inhomogeneous cross sections, the method combines the finite element and boundary element techniques. Interior to a fictitious surface enclosing the scattering body, the finite element method is used which results in a sparse submatrix, whereas along the enclosure the Stratton-Chu integral equation is enforced. By choosing the fictitious enclosure to be a right circular cylinder, most of the resulting boundary integrals are convolutional and may therefore be evaluated via the FFT with the system is iteratively solved. In view of the sparse matrix associated with the interior fields, this reduces the storage requirement of the entire system to $O(N)$ making the method attractive for large scale computations. This report describes the details of the corresponding formulation and its numerical implementation.

Preface

This semi-annual report describes our progress during the period from September 1990 to February 1991. Two specific tasks are described and each should be read independently. That is, figure and reference numbering is consecutive only within the description of the task. As can be expected the progress reports are very brief and the reader should refer to the referenced technical reports for detailed coverage. A total of 23 journal articles, 17 conference publications and 18 technical reports have been written since the beginning of the Grant. A complete list of these is given in pp. 40-45.

A FINITE ELEMENT – BOUNDARY INTEGRAL METHOD FOR
SCATTERING AND RADIATION BY TWO- AND
THREE-DIMENSIONAL STRUCTURES

Jian-Ming Jin, John L. Volakis, and Jeffery D. Collins

Radiation Laboratory

Department of Electrical Engineering and Computer Science

The University of Michigan

Ann Arbor, Michigan 48109-2122

ABSTRACT

This paper presents a review of a hybrid finite element – boundary integral formulation for scattering and radiation by two- and three-dimensional composite structures. In contrast to other hybrid techniques involving the finite element method, the proposed one is in principle exact and can be implemented using a low $O(N)$ storage. This is of particular importance for large scale applications and is a characteristic of the boundary chosen to terminate the finite element mesh, usually as close to the structure as possible. A certain class of these boundaries lead to convolutional boundary integrals which can be evaluated via the fast Fourier transform (FFT) without a need to generate a matrix, thus, retaining the $O(N)$ storage requirement. The paper begins with a general description of the method. A number of two- and three-dimensional applications are then given, including numerical computations which demonstrate the method's accuracy, efficiency and capability.

APPLICATIONS OF THE CONJUGATE GRADIENT FFT METHOD IN
SCATTERING AND RADIATION INCLUDING SIMULATIONS
WITH IMPEDANCE BOUNDARY CONDITIONS

Abstract

The theoretical and computational aspects related to the application of the Conjugate Gradient FFT (CGFFT) method in computational electromagnetics are examined. The advantages of applying the CGFFT method to a class of large scale scattering and radiation problems are outlined. The main advantages of the method stem from its iterative nature which eliminates a need to form the system matrix (thus reducing the computer memory allocation requirements) and guarantees convergence to the true solution in a finite number of steps. Moreover, since the CGFFT algorithm is highly vectorizable, it can be efficiently implemented on supercomputers and multiprocessor machines.

Results are presented for various radiators and scatterers including thin cylindrical dipole antennas, thin conductive and resistive strips and plates, as well as dielectric cylinders.

Solutions of integral equations derived on the basis of generalized impedance boundary conditions (GIBC) are also examined. These boundary conditions can be used to replace the profile of a material coating by an impedance sheet or insert, thus, eliminating the need to introduce unknown polarization currents within the volume of the layer. Moreover, by applying these surface boundary conditions, the difficulties associated with the calculation of the Green's function are avoided. Impedance boundary conditions of up to the third order are employed and shown to be compatible with the basic CGFFT formulation, allowing an efficient simulation of large coated structures and filled cavity-backed apertures by further reducing the memory demand. For the purpose of validation of these simulations, a general full-wave analysis of two- and three-dimensional rectangular grooves and cavities is presented which will also serve as reference for future work.

USE OF EDGE-BASED FINITE ELEMENTS FOR
SOLVING THREE DIMENSIONAL SCATTERING
PROBLEMS

A. Chatterjee, J.M. Jin and J.L. Volakis
Radiation Laboratory
Department of Electrical Engineering and Computer Science
University of Michigan
Ann Arbor, MI 48109-2122

Abstract

Edge-based finite elements are free from the drawbacks associated with node-based vectorial finite elements and are, therefore, ideal for solving three-dimensional scattering problems. The finite element discretization using edge elements is checked by solving for the resonant frequencies of a closed inhomogeneously filled metallic cavity. Significant improvements in accuracy are observed when compared to the classical node-based approach with no penalty in terms of computational time and with the expected absence of 'spurious' modes. A performance comparison between the edge-based tetrahedra and rectangular brick elements is carried out and tetrahedral elements are found to be more accurate than rectangular bricks for a given storage intensity. A detailed formulation for the scattering problem with various approaches for terminating the finite element mesh is also presented.