

179 9211
IN-39-CR
48077
P-18

TECHNION RESEARCH AND DEVELOPMENT FOUNDATION LTD.

TECHNION CITY, HAIFA 32000, ISRAEL

Annual Report on Research No. 160-573:

Multi-Disciplinary Optimization of Aeroservoelastic Systems

Sponsored by NASA Grant NAGW-1708

Principal Investigator: Mordechay Karpel, Associate Professor

Faculty of Aerospace Engineering

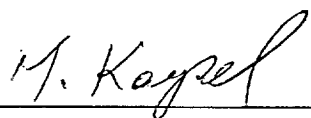

Principal Investigator

October 21, 1991

Date

© 1991 by Mordechay Karpel, National Aeronautics and Space Administration, and
the Technion Research and Development Foundation Ltd.

The purpose of the research project "Multi-Disciplinary Optimization of Aeroservoelastic Systems" in its second year (from October 1990 to September 1991) was to continue the development of new methods for efficient aeroservoelastic analysis and optimization. The main target was to develop a method for investigating large structural variations using a single set of modal coordinates. This task has been accomplished by basing the structural modal coordinates on normal modes calculated with a set of fictitious masses loading the locations of anticipated structural changes.

The first part of this work, "Modal Coordinates for Aeroelastic Analysis with Large Local Structural Variations", has been presented at the European Forum on Aeroelasticity and Structural Dynamics, Aachen, Germany, June 1991. The paper was co-authored by Carol D. Wieseman of NASA Langley. The abstract is given in Appendix A. The paper has also been submitted for publication in the AIAA Journal of Aircraft. The second part of this work, "Time Simulation of Flutter with Large Stiffness Changes", has been proposed, together with Carol Wieseman, for presentation at the 33rd Structures, Structural Dynamics and Materials Conference, April 1992. The submitted extended abstract is given in Appendix B.

Another work on sensitivity derivatives for residualized aeroservoelastic optimum-design models has been performed together with Israel Herszberg of RMIT Victoria University of Technology, Australia, while he was on sabbatical at the Technion. The abstract of the paper on this work that has also been presented in the Aachen Conference mentioned above is given in Appendix C.

Two other subjects that I worked on together with graduate students are aeroservoelastic optimization with continuous gust response constraints (with Arie Zole) and dynamic response to impulsive excitation (with Eyal Presante).

The target in both cases is to develop efficient numerical procedures for inclusion in the multi-disciplinary optimization scheme. It is anticipated that the first subject will be incorporated in the FASER optimization program by June, 1992, and the second subject before the end of 1992.

A preliminary investigation has been started, in cooperation with Shlomo Taason of ICASE on the inclusion of static aeroelastic effect in CFD shape optimization. Initial guidelines for 2-D optimization are given in Appendix D. The basic principles will be applied to 3-D optimization at a later stage.

Appendix A

MODAL COORDINATES FOR AEROELASTIC ANALYSIS WITH LARGE LOCAL STRUCTURAL VARIATIONS

M. Karpel

C.D. Wieseman

Faculty of Aerospace Engineering
Technion-Israel Institute of Technology

NASA Langley Research Center
Hampton, Virginia

The investigation of the effects of local structural property variations on flutter and aeroelastic response is an important phase of the design of flight vehicles. Common aeroelastic analyses start with the calculation of a limited set of normal vibration modes which serve as generalized coordinates. Repeated calculations of the normal modes and the associated generalized aerodynamic force coefficients every time a structural property changes may be impractical. An additional problem is how to deal with the changing coordinates during time-domain response simulations. These problems can be resolved by performing the entire analysis with a constant set of modal coordinates. Various applications used the vibration modes of a nominal structure as generalized coordinates and account for structural changes by introducing stiffness, mass and damping coupling terms. However, the application of this approach to cases of large structural variations may either yield inaccurate results or require a very large number of modes.

The approach taken in this work is to calculate the constant set of modal coordinates with the free-free structure loaded with fictitious masses at the vicinity of the varying stiffness. The application of relatively large fictitious masses causes significant local deformations in the low frequency modes. This facilitates high accuracy usage of a small number of modal coordinates over a wide range of local stiffness variations. The fictitious masses are removed in the analysis by appropriate mass coupling terms. Damping coupling terms are introduced to yield the desired modal damping values at air off conditions.

The numerical examples deal with a realistic aeroelastic system of an aircraft with a tip store. The wing-store pitch stiffness properties are subject to change by a factor of 30, which has a drastic effect on the flutter characteristics. It is first shown that without fictitious masses the transition-by-coupling from one configuration to the other causes significant errors of critical natural frequencies even with 60 modes taken into account. The introduction of a single fictitious mass yields very accurate frequencies with as few as 10 modes taken into account. A parametric study shows that the results are insensitive to the value of the fictitious mass provided that it is above a certain value but not large enough to cause ill-conditioning. The state-space aeroelastic equations of motion are formulated using minimum-state rational approximations of the unsteady aerodynamic forces. The differences between flutter velocities and frequencies obtained by coupling, and those obtained by direct solutions are less than 3%.

Appendix B

TIME SIMULATION OF FLUTTER WITH LARGE STIFFNESS CHANGES

Mordechay Karpel
Technion-Israel Institute of Technology
Haifa, Israel

Carol D. Wieseman
NASA Langley Research Center
Hampton, VA 23665-5225

INTRODUCTION

The common approach for formulating the equations of motion of aeroelastic systems starts with normal modes analysis of the structural model. Unsteady aerodynamic force coefficient matrices are then calculated at various reduced frequency values to account for the aerodynamic coupling between these modes while undergoing oscillatory motion. Classic frequency-domain aeroelastic analysis methods use the modal structural properties and the tabulated aerodynamic matrices for calculating the flutter conditions at which the aeroelastic system matrix is neutrally stable. The basic assumption of the modal approach is that the structural deflections of the aeroelastic system are linear combinations of a limited set of low frequency vibration modes.

Time-domain aeroelastic modeling techniques, which cast the equations of motion in a state-space, time-invariant form, call for the approximation of the aerodynamic matrices by rational functions in the Laplace domain. The order of the resulting state-space model is a function of the number of selected modes, the number of aerodynamic approximation roots, and the approximation formula. The main considerations in constructing the model are its size (which affects the efficiency of the subsequent analyses), its accuracy, and the model construction efforts.

Various computational schemes such as structural optimization, parametric studies, the investigation of damage effects, and structural changes during dynamic response, require

repeated construction of the model for numerous structural variations. Repeated calculation of the normal modes and the associated aerodynamic matrices every time the structure changes is often impractical in these cases. A more practical approach is to introduce structural changes without changing the modal coordinates. The validity of this approach depends on the structural information contained in the modal coordinates and the magnitude of the structural changes. The number of required modes increases with the magnitude of the allowable structural move limits. Keeping the modal coordinates unchanged is even more important in time simulation of aeroelastic response during which structural changes occur. The occurrences of structural changes define the time segments between which the model changes. The end conditions of one segment are the initial conditions of the following one. One can argue that these transition-point conditions can be transformed to a set of new coordinates. But this transformation is adequate only if the new coordinates can be expressed as a linear combination of the old ones. However, if this is the case, there is also no need to change the modal coordinates in the first place.

Various structural optimization procedures, like that of Ref. 1, demonstrated that moderate structural changes can be accommodated without changing the modal coordinates. In order to accommodate large structural changes, the modes that serve as generalized coordinates must contain significant distortions in the vicinity of the changes. Taking into account more modes supports this purpose but may result in an excessively large aeroelastic model. A method for accommodating large structural changes at a small number of structural locations, without significantly increasing the model size has been presented in Ref. 2. The procedure starts with calculating a set of low frequency vibration modes with the structure loaded with large fictitious masses at the location of anticipated structural changes. The fictitious masses cause the vibration modes to contain the local deformations required for an adequate accommodation of large structural changes.

The purpose of the proposed paper is to outline the process of using fictitious-mass modes to generate efficient fixed-coordinate time-domain aeroelastic models for dynamic response and loads analyses, and to demonstrate the usage of these models for time simulation of flutter during which large local stiffness changes occur.

SELECTED RESULTS

The numerical example consists of a mathematical model of the AFW wind-tunnel model tested at the NASA Langley Research Center. An external store is connected to the tip of the wing through a decoupling mechanism designed to decouple the pitch motion of the store from that of the wing when flutter occurs. With "stiff" or "coupled" pitch connection, the Mach 0.9 antisymmetric flutter dynamic pressure is about 1.9 psi and the flutter frequency is about 12 Hz. When the decoupling mechanism is activated, the pitch connection stiffness is reduced by 96.5% ("soft" or "decoupled") and the flutter conditions change to 2.9 psi, 31 Hz, namely a drastic change in both flutter dynamic pressure and the flutter mechanism.

The fictitious-mass finite-element (NASTRAN) model is with the soft pitch connection and with a fictitious pitch inertia of 3 lb-in-sec², twice that of the tip store, loading the wing end of the pitch spring. A set of 14 low frequency vibration fictitious-mass (FM) modes is used to generate the basic stiff model. A comparison between the first seven natural frequencies obtained directly from NASTRAN and those calculated from the 14 FM modes and from 14 soft modes without fictitious masses is given in Table 1. It is clear that the FM model produces accurate frequencies while the flutter critical store pitch frequency obtained from the soft model without fictitious mass is 18% higher than the correct one.

The 14 FM modes were used to generate a time domain aeroelastic model for the stiff case using Minimum-State rational approximation of the unsteady aerodynamics³ with 8 aerodynamic augmenting states. The transition to the soft condition is performed by simply introducing the appropriate stiffness coupling terms and damping coupling terms (to yield an

effective diagonal modal damping matrix). The modal coordinates, as well as the associated aerodynamic terms, remain unchanged. A comparison between flutter conditions calculated by the frequency domain p-k method and those obtained from the root-locus analysis of the state-space models is given in Table 2. While the direct stiff and soft cases required full analyses starting from separate finite-element models, the FM results were obtained from models that are based on the same modal coordinates and aerodynamic coefficients.

The adequacy of the FM model for time simulation is checked by comparing responses to initial conditions with those obtained by the direct models. The dynamic pressure at which responses are calculated is 2.5% higher than the stiff flutter dynamic pressure. The vertical acceleration responses of the forward and rear tip-store points are given in figure 1 for the stiff case and in figure 2 for the soft case. The development of flutter at this dynamic pressure and the decay due to activation of the decoupling mechanism are simulated in figure 3. The transition from stiff to soft is performed by introducing the appropriate coupling terms between the structural states of the FM model. The only output equations that need to be changed in the transition are those involve acceleration response. It can be observed that the system stabilizes very fast but there may be significant overshoots in the transition.

CONCLUDING REMARKS

Normal modes calculated with fictitious masses at selected structural locations form a set of generalized coordinates with which aeroelastic systems can be analyzed over a wide range of stiffness changes in the vicinity of these location. The values of the fictitious masses can be arbitrarily chosen from a wide range of masses that cause significant local deformations in the low frequency modes, without causing numerical ill conditioning. The physically weighted minimum-state rational approximation of the unsteady aerodynamic force coefficient matrices is performed once for all the stiffness variations. The size of the resulting time-domain model is similar to those required for the analyses of each stiffness

case separately. The model facilitates an efficient simulation of aeroelastic time response during which large stiffness changes occur. A numerical application demonstrated a flutter divergence followed by rapid convergence due to the activation of a decoupling mechanism which reduces the stiffness of a critical element by 96.5%. The example demonstrates that the activation of the decoupler may cause a transient overshoot before the system stabilizes.

REFERENCES

¹Karpel, M., "Multidisciplinary Optimization of Aeroservoelastic Systems," presented at the Air Force/ NASA Symposium on Multidisciplinary Analysis and Optimization, San Francisco, CA, Sept. 1990.

²Karpel, M. and Wieseman, C.D., "Modal Coordinates for Aeroelastic Analysis with Large Local Structural Variations," presented at the European Forum on Aeroelasticity and Structural Dynamics, Aachen, Germany, April 1991.

³Karpel, M. and Hoadley, S.T., "Physically Weighted Approximations of Unsteady Aerodynamic Forces Using the Minimum-State Method", NASA TP 3025, March 1991.

FIGURES

1. Time response to initial condition, stiff store connection.
2. Time response to initial condition, soft store connection.
3. Time simulation of flutter with stiff-to-soft transition.

Table 1. Natural frequencies of the stiff model

Number	direct from NASTRAN	from soft with FM	from soft without FM	Description
1	0	0	0	rigid-body roll
2	7.023	7.024	7.032	1st fuselage bending
3	7.856	7.864	7.980	1st wing bending
4	13.069	13.179	15.41	store pitch
5	16.161	16.134	16.43	2nd fuselage bending
6	27.408	27.410	27.47	3rd wing bending
7	38.271	38.300	38.76	1st wing torsion

Table 2. Flutter results with different models.

store connection	Frequency domain		State Space			
	p-k 13 modes		direct 13 modes		from FM model 14 modes	
	q_f (psi)	ω_f (Hz)	q_f (psi)	ω_f (Hz)	q_f (psi)	ω_f (Hz)
stiff	1.889	11.88	1.884	11.89	1.918	11.94
soft	2.958	30.88	2.948	30.78	3.077	30.94

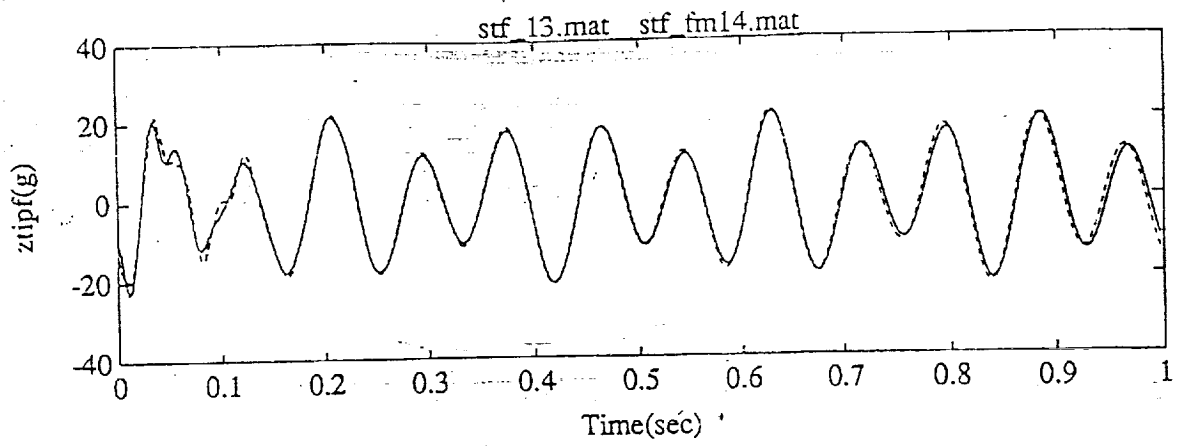

a) Acceleration near forward end of tip missile, g's.

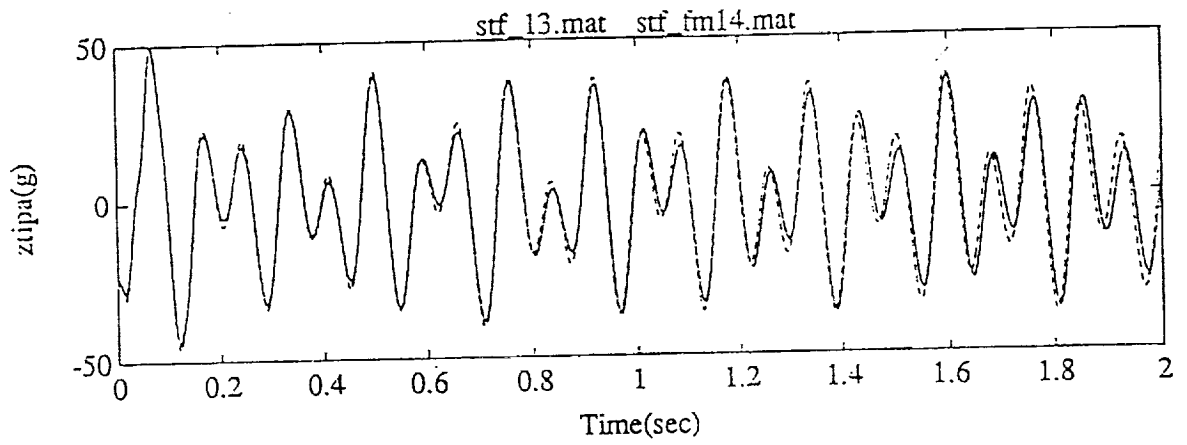

b) Acceleration near rear end of tip missile, g's.

Figure 1. Time response to initial condition, stiff store connection.

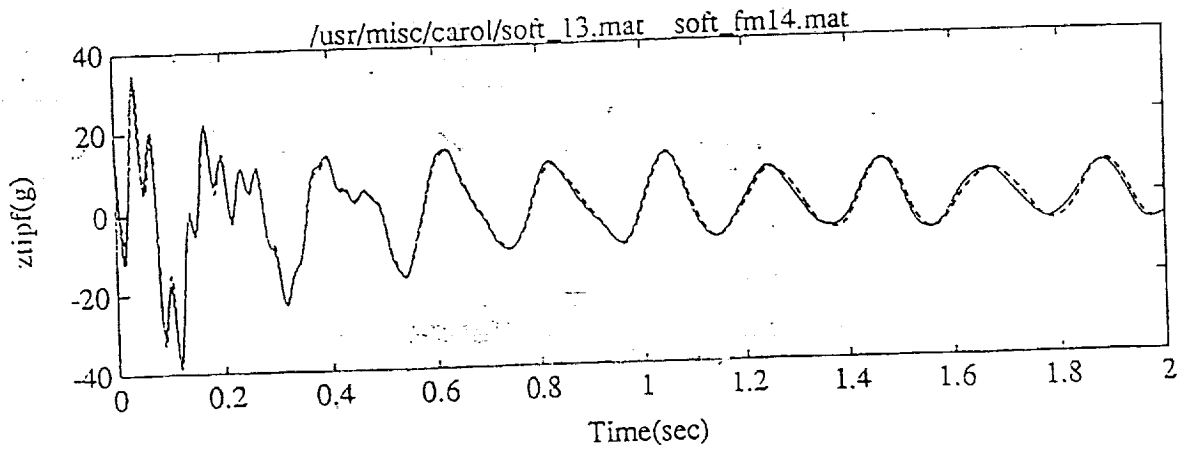

a) Acceleration near forward end of tip missile, g's.

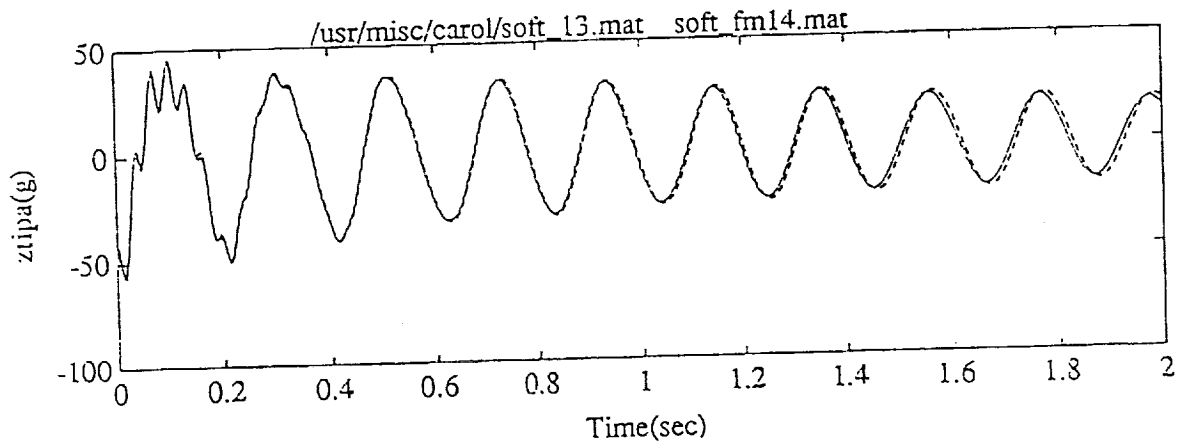

b) Acceleration near rear end of tip missile, g's.

Figure 2. Time response to initial condition, soft store connection.

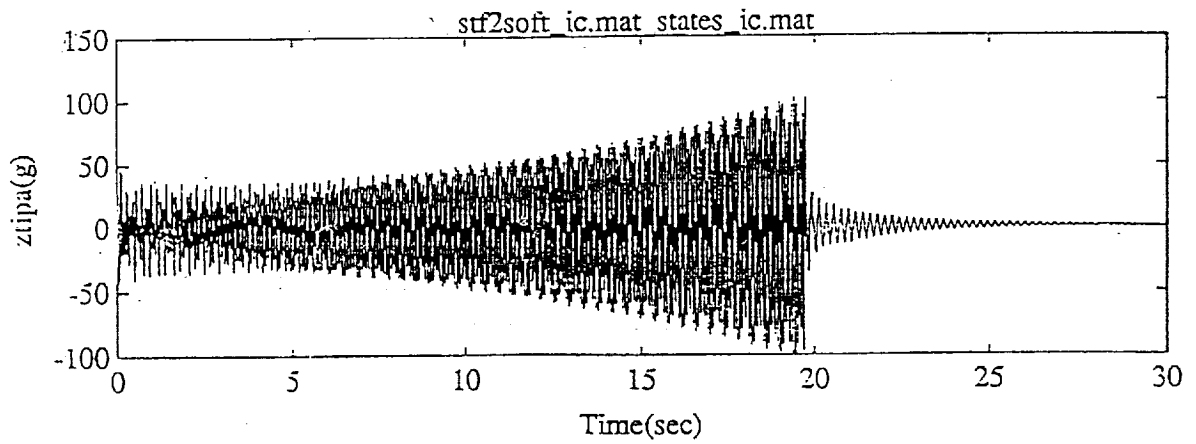

a) Acceleration near rear end of tip missile, g's.

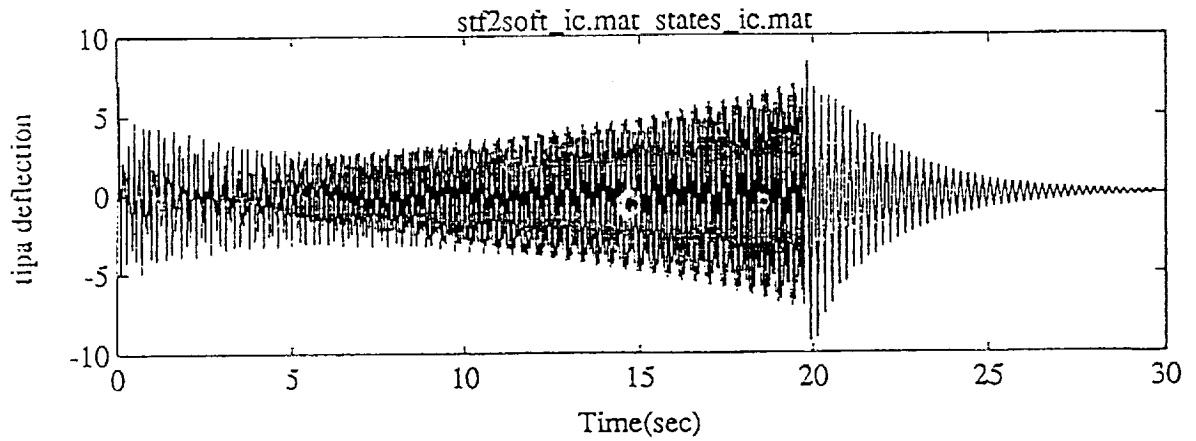

b) Deflection near rear end of tip missile, in.

Figure 3. Time simulation of flutter with stiff-to-soft transition.

ABSTRACT FORM

(Please use this form for your abstract. A reprint will be published in a booklet of abstracts.)

Title ▶ **SENSITIVITY DERIVATIVES FOR RESIDUALIZED AEROSERVOELASTIC OPTIMUM DESIGN MODELS**

Author(s) ▶ **Israel Herszberg** **Mordechay Karpel**

Company/
Affiliation ▶ **Centre for Aerospace Design Technology** **Faculty of Aerospace Engineering**
RMIT Victoria University of Technology **Technion-Israel Institute of Technology**

Text ▶ Analytical expressions for the sensitivity derivatives of flutter dynamic pressure and control
1½-spaced design criteria, with respect to structural and control design variables are extended to deal with residualized aeroservoelastic models.

The model considered is a first-order time-domain feedback system subject to model size reduction by means of residualization. The structure is represented by a number of structural vibration modes, the aerodynamics by rational approximation functions and the control system couples control surface motion to the response of motion sensors located on the structure.

The dynamic residualization technique and the minimum-state approximation method for aerodynamic modelling have been demonstrated to yield a relative low order, high accuracy model which may be used for on-line design studies where fast response time is important. The extended formulation and new techniques of this work make the calculations more efficient and further enhance on-line design studies.

To date the optimal design process makes use of the reduced order system to calculate flutter dynamic pressures and gain margins, but reverts to the full model for the calculation of stability derivatives. The calculation of sensitivity derivatives depends on the special topography of the system matrices which is not preserved by the residualization process. A large proportion of the computation time is spent in calculating these derivatives, particularly if there is a large number of design variables. The techniques presented in this work allow the calculation of sensitivity derivatives for the reduced order system. The consequent reduction in computation time for the stability derivatives is of the order of the square of the ratio of the numbers of states.

A realistic numerical example of the optimal design of an aeroservoelastic system comprising a carbon-composite wing with four control surfaces is used to demonstrate the method and to compare the results with those obtained by using sensitivity derivatives computed from the full model. The optimization minimizes the structural weight with respect to structural and control variables, subject to aeroelastic, control and design constraints.

The use of sensitivity derivatives calculated for the reduced system decreases significantly the time taken for the optimization and consequently enhances the optimization method as an on-line design tool.

Appendix D

M. Karpel, August 19, 1991

Aeroelastic Effects in 2-D Shape Optimization

A given airfoil is subjected to 2-D flow as shown in Figure 1. The "nominal" (or "rigid") angle of attack and trailing-edge control surface deflection are α_0 and δ_0 . The x axis is parallel to the nominal chord line which connects the leading and trailing edges when $\alpha = \alpha_0$ and $\delta = \delta_0 = 0$. The actual angle of attack (α) is related to the nominal one by

$$\alpha = \alpha_0 + \alpha_e \quad (1)$$

where α_e is the elastic deformation of a pitch spring of stiffness k_α located at the elastic axis at $x = cx_e$, $z = cz_e$ and connecting the airfoil to the α setup mechanism (which commands α_0). The pitch elastic equilibrium equation is

$$M = k_\alpha \alpha_e \quad (2)$$

where M is the aerodynamic pitching moment about the elastic axis. The actual control surface deflection (δ) is related to the nominal one by

$$\delta = \delta_0 + \delta_e \quad (3)$$

where δ_e is the elastic deformation of the actuator spring k_δ representing the actuator stiffness and located at $x = cx_h$, $z = cz_h$. The associated equilibrium equation is

$$H = k_\delta \delta_e \quad (4)$$

where H is the aerodynamic hinge moment about the hinge line located at $x = cx_h$.

The aerodynamic moments are

$$M = q \int_0^c C_{p_u} [x - cx_e + z_u'(z_u - cz_e)] dx - q \int_0^c C_{p_l} [x - cx_e - z_l'(z_l - cz_e)] dx \quad (5)$$

and

$$H = q \int_{cx_h}^c C_{p_u} [x - cx_h + z_u'(z_u - cz_h)] dx - q \int_{cx_h}^c C_{p_l} [x - cx_h - z_l'(z_l - cz_h)] dx \quad (6)$$

where $q = \frac{1}{2}\rho V^2$ is the dynamic pressure, C_p is the surface pressure coefficient, and subscripts u and l relate to the upper and lower surfaces respectively. z_u and z_l are the upper and lower surface coordinates.

It is assumed that the optimization shape functions include α_0 , α_e , δ_0 and δ_e as design variables. α_0 is usually utilized by rotating the x-z axes relative to the velocity direction. α_e defines the shape function

$$f_\alpha = x_e - x/c \quad (7)$$

The elastic axis and hinge line z locations are defined after geometry changes by the average of the local z_u and z_l values. The shape function associated with both δ_0 and δ_e is

$$f_\delta = \begin{cases} 0 & \text{if } x \leq cx_h \\ x_h - x/c & \text{otherwise} \end{cases} \quad (8)$$

The shape functions of Eqs. (7) and (8) are used to define both upper and lower surfaces.

The elastic parameters α_e and δ_e should be treated as dependent variables tuned to satisfy the equality constraints of Eqs. (2) and (4). The CFD calculations in each iteration result in M and H , and their sensitivity derivatives w.r.t. all design variables including α and δ . To estimate the changes in α_e and δ_e required to satisfy these constraints, we can use

$$\begin{Bmatrix} M \\ H \end{Bmatrix} + qc^2 \begin{bmatrix} C_{M_\alpha} & C_{M_\delta} \\ C_{H_\alpha} & C_{H_\delta} \end{bmatrix} \begin{Bmatrix} \Delta\alpha_e \\ \Delta\delta_e \end{Bmatrix} = \begin{bmatrix} k_\alpha & 0 \\ 0 & k_\delta \end{bmatrix} \begin{Bmatrix} \alpha_e + \Delta\alpha_e \\ \delta_e + \Delta\delta_e \end{Bmatrix} \quad (9)$$

where $C_M = M/qc^2$ and $C_H = H/qc^2$ which yields

$$\begin{Bmatrix} \Delta\alpha_e \\ \Delta\delta_e \end{Bmatrix} = \left(\begin{bmatrix} k_\alpha & 0 \\ 0 & k_\delta \end{bmatrix} - qc^2 \begin{bmatrix} C_{M_\alpha} & C_{M_\delta} \\ C_{H_\alpha} & C_{H_\delta} \end{bmatrix} \right)^{-1} \left(\begin{Bmatrix} M \\ H \end{Bmatrix} - \begin{bmatrix} k_\alpha & 0 \\ 0 & k_\delta \end{bmatrix} \begin{Bmatrix} \alpha_e \\ \delta_e \end{Bmatrix} \right) \quad (10)$$

At the end of the iteration, all objective functions and their sensitivity derivatives are modified to reflect the effects of the constrain equations, as done for other equality constraints.

It should be noted that if the optimization is performed for one set of flow conditions and required lift, it can be performed without aeroelastic effects. After the optimal α_0 and δ_0 are found, M and H are calculated by Eqs. (5) and (6), α_e and δ_e are then calculated by Eqs. (2) and (4), which yields the actual α and δ of Eqs. (1) and (3). A multipoint optimization, however, and off-optimum calculations, require the inclusion of aeroelastic effects. It is suggested to perform an optimization case with a rigid airfoil first (with α and δ serving as design variables among others). The elastic deformations can then be calculated as described above. Another optimization can now be performed for the elastic airfoil when the optimal result is known a-priori. This will help studying potential problems associated with introducing aeroelastic effects. The formulation given above can be extended to 3D optimization by replacing the α_e and δ_e parameters by elastic modal deflections that will also serve as wing shape functions.

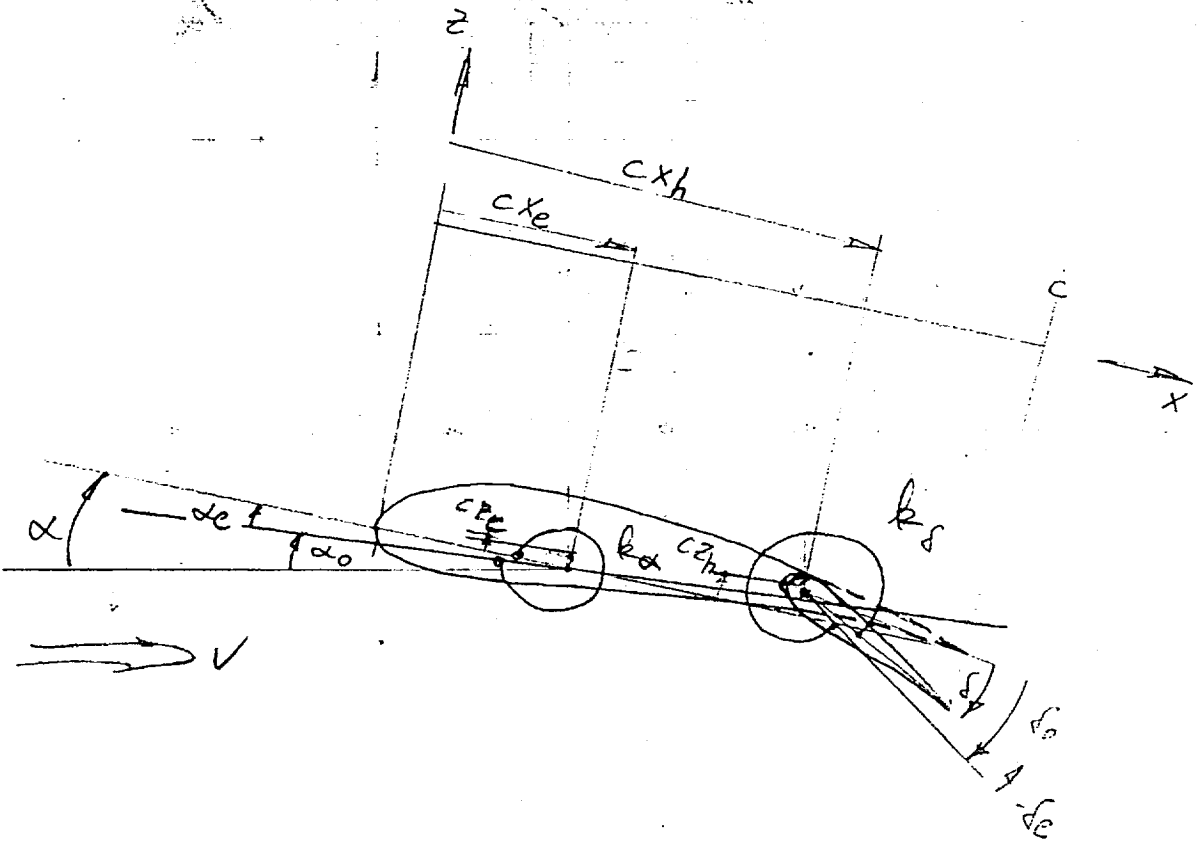

Figure 1: 2-D Airfoil