

**DEVELOPMENT OF HIGH  $T_c$  (>110K) Bi, Tl and Y-BASED MATERIALS  
AS SUPERCONDUCTING CIRCUIT ELEMENTS**

**SEMI-ANNUAL REPORT**

**to**

**National Aeronautics and Space Administration  
Langley Research Center  
Hampton, VA 23665-5225**

**Period: February, 1991 - October, 1991**

**Principal Investigator:**

**Gene Haertling**

**Supporting Investigators:**

**Gregory Grabert**

**Phillip Gilmour**

**Contract No. NAG-1-1108**

**November 11, 1991**



**CLEMSON  
UNIVERSITY**

**Department of Ceramic Engineering  
College of Engineering**

## Summary

Experimental work has continued on the development and characterization of bulk and hot pressed powders and tapecast materials in the Bi-Sr-Ca-Cu-O and Tl-Ba-Ca-Cu-O systems. A process for producing warp-free, sintered, superconducting tapes of Bi composition  $\text{Bi}_2\text{Sr}_2\text{Ca}_2\text{Cu}_3\text{O}_x$  has been established. This procedure requires a triple calcination at  $830^\circ\text{C}$  for 24 hours and sintering at  $845^\circ\text{C}$  from 20 to 200 hours. Hot pressing the triple calcined powder at  $845^\circ\text{C}$  for 6 hours at 5000 psi yielded a dense material which on further heat treatment at  $845^\circ\text{C}$  for 24 hours exhibited a  $T_c$  of 108.2K. As anticipated, the Bi compositions were found to be much less oxygen sensitive than the Y compositions (123). This was especially noted in the case of the hot pressed materials which were superconducting ( $T_c = 82\text{K}$ ) as hot pressed - a condition which could not be achieved in the Y compositions. Safire-type grounding links are in the process of being fabricated from these materials.

The procedure for producing reproducible bulk and tapecast material of Tl composition  $\text{Tl}_2\text{Ba}_2\text{Ca}_2\text{Cu}_3\text{O}_x$  is still in progress. Additives of Li and Mn were made to the base composition in order to lower the sintering temperature and thereby reduce the volatilization of the thallium oxide. Although this was partially successful in the bulk material, the tapecast materials were found to be especially difficult to process since the reducing conditions, which were produced during the burnoff of the binder resin, were also instrumental in reducing thallic oxide ( $\text{Tl}_2\text{O}_3$ ) to the more volatile thallos oxide ( $\text{Tl}_2\text{O}$ ). To date, the highest  $T_c$  produced in a Tl-based tapecast material is 106.5K.

## I. Introduction

This report details work that was carried out over the period from February, 1991 thru October, 1991, in the Ceramic Engineering Department of Clemson University under NASA contract No. NAG-1-1108. The work described in this report is part of the second year of a program involving the development of high Tc superconducting circuit elements in the Bi-Sr-Ca-Cu-O and Tl-Ba-Ca-Cu-O compositional systems. This effort is intended to build on the results of the previous contract (NAG-1-820) which involved the development of the  $\text{Yba}_2\text{Cu}_3\text{O}_{7-x}$  (123) material in circuit elements; and more specifically, a superconducting grounding link for the SAFIRE (Spectroscopy of the Atmosphere using Far Infra-Red Emission) program.

The technology developed for the SAFIRE grounding link involves a rigid-structure approach to superconducting elements rather than the flexible-wire idea promoted by most other institutions. In principle, the rigid-structure concept is quite simple and is tailor-made to take advantage of the inherent desirable properties of the superconducting ceramics while at the same time recognizing the low strength and basic brittleness of these materials. This is accomplished by pre-forming, sintering and testing the ceramic superconductor prior to bonding it to a rigid supporting substrate which is then totally encapsulated for further support and environmental protection. This approach has the advantages of (1) pre-testing of the superconducting material separate from the substrate, (2) optimization of the development of superconductivity in the ceramic without temperature limitations imposed by the substrate, (3) wider selection of substrate materials since the high temperature processing step precedes mounting of the superconductor to the printed circuit board, (4) freedom from firing shrinkage and other material compatibility problems and (5) high anticipated reliability because of its simplicity, rigid design and total encapsulation from the environment.

The report is presented in two parts; i.e., Part I dealing with the Bi-based materials and Part II covering work on the Tl-based materials.

**Semi-Annual Report**

**Development of High  $T_c$  (>110 K) Bi, Tl and Y-Based  
Materials as Superconducting Circuit Elements**

**Submitted to**

**National Aeronautics and Space Administration  
Langley Research Center**

**Submitted by**

**Gregory Grabert**

**Principle Investigator**

**Gene H. Haertling**

**Department of Ceramic Engineering**

**Clemson University**

**Contract No. Nag-1-1108**

**October 1991**

## I. Introduction

Since the discovery of a High  $T_c$  superconducting phase in the Bi-Sr-Ca-Cu-O (BSCCO) system by Maeda and his coworkers<sup>(1)</sup>, extensive work has been done to fabricate devices out of these materials. Ceramic superconducting devices in the Y-Ba-Cu-O system have been fabricated at Clemson University using the rigid conductor process (RCP)<sup>(2,3)</sup> for the SAFIRE (Spectroscopy of the Atmosphere using Far Infra-Red Emission) program. This process is currently being applied to the bismuth-based materials because the bismuth-based materials have several advantages over the yttrium-based materials. Besides having a critical temperature ( $T_c$ ) of 110 K as compared to that of 92 K for the yttrium-based material, the bismuth-based material (1) is less oxygen stoichiometry sensitive than the yttrium-based material, (2) is resistant to moisture degradation, unlike the yttrium and thallium-based materials and (3) has a higher intrinsic critical current density ( $J_c$ ) than the yttrium-based material and with better grain alignment could possibly have higher extrinsic  $J_c$ .

This report contains the sample preparation for the bulk and tapecast bismuth-based materials and the preliminary results obtained since June, 1991.

## II. Experimental Procedure

Figure 1 shows the preparation process for the uniaxial and hot pressed bulk bismuth-based material. Figure 2 shows the preparation process for the tapecast bismuth-based material. In all cases, the starting materials were  $\text{Bi}_2\text{O}_3$ ,  $\text{PbO}$ ,  $\text{SrCO}_3$ ,  $\text{CaCO}_3$  and  $\text{CuO}$ . The powders were weighed out and ball milled with distilled water for one hour and dried at 100 °C for eighteen hours. The dried powder was then pressed into pellets and calcined at 810 °C for twelve hours and once or twice at 830 °C for twenty-four hours depending on the process. The calcined powder was then ground with a mortar and pestle for processing into the bulk and tapecast material. For the uniaxially pressed material, the calcined

powder was pressed into one square inch pellets and sintered at 845 °C for twenty to two hundred hours in air. For the hot pressed material, the calcined powder was hot pressed at 5000 psi for six hours at 845 °C in oxygen. This material was then tested or subjected to an additional heat treatment of twenty-four hours at 845 °C in air. The furnace schedule for the bulk material can be seen in Figure 3. For the tapecast material, the calcined powder was ball milled with trichloroethylene for one hour and dried at 100 °C for eighteen hours. The dried powder was then mixed with a commercial binder, B73305 from Metoramic Sciences, Inc., in the ratio of 150 grams of powder to 80 grams of binder and ball milled for one hour. The mixture was deaired for ten minutes and tapecast by a conventional tapecasting processes<sup>(4)</sup>. The tape was cut into strips with the dimensions 25.4 mm x 2.0 mm x 0.5 mm. The strips were sintered by a single and double ramp process. In the single ramp process the tapes were sintered at 845 °C for twenty-eight to forty-eight hours in air using the furnace schedule seen in Figure 3. In the double ramp process, the tapes were covered and sintered at 500°C to 800°C for two hours, cooled down to room temperature, uncovered and sintered at 845 °C for thirty hours in air. Tapes were also sintered covered at 845 °C for thirty hours using the double ramp process. The furnace schedule for the double ramp process can be seen in Figure 4. The electrodes for all materials were applied using a commercial silver paste, C8710 from Heraeus Inc., Cermalloy Division, and fired at 845 °C for eighteen minutes. All of the materials were first tested for the Meissner effect. The critical temperature and critical current density for both the bulk and the tapecast materials were evaluated using a standard four point method. The resistance was measured by a Keithley, Model 580, micro-ohmmeter with a sensitivity of  $10^{-6} \Omega$ . The critical currents were measured using a 1  $\mu$ V per mm standard by a Keithley, Model 197, Autoranging MicroVolt DMM. In addition, the structures of the samples were examined by powder X-ray diffraction (XRD) using Cu  $K_{\alpha}$  radiation. Scanning electron microscopy (SEM) was used to observe the homogeneity and surface morphology of the materials.

### III. Results and Discussion

#### 1. BSCCO Bulk Material

Figure 5 shows the resistance versus temperature curve for the hot pressed compact which was prepared at 845 °C for six hours in oxygen at 5000 psi. The curve showed that the material had a sharp transition to the superconducting state at 83.3 K. Figure 6 shows the resistance versus temperature curve for the same compact with an additional twenty-four hour heat treatment at 845 °C in air. The curve showed that the material now has a sharp transition to the superconducting state at 108.2 K. This material is now less dense, the bulk density dropped from 6.18 to 6.01 g/cc, but the additional twenty-four hour heat treatment has increased the  $T_c$  by almost 25 K. From the SEM micrographs, shown in Figure 7, one can see that the compact with no additional heat treatment appears to be a very dense melt with no apparent grain structure, but the heat treated compact's structure now has grain growth and the grains exhibit the same flaky behavior seen before in the bulk uniaxially pressed material<sup>(5)</sup>. The bulk uniaxially pressed compact had to be sintered for two-hundred hours to reach the same  $T_c$  as the heat treated compact<sup>(5)</sup>. The reason the hot pressed compact can be converted to the higher  $T_c$  phase in a substantially shorter amount of time is due to the compact being much more dense and uniform than the uniaxially pressed pellet making the driving force for conversion much higher.

A preliminary study of the effect the number of calcinations had on the superconducting properties of the uniaxially and hot pressed material was done. In the uniaxially pressed material sintered for thirty hours at 845 °C in air, shown in Figure 8, the two times calcined material had a  $T_c$  of 99.1 K, whereas the three times calcined material had a  $T_c$  that was 3 K higher at 102.0 K. In the hot pressed material with no additional heat treatment, shown in Figure 9, the two times calcined material did not superconduct, while the three times calcined material had a  $T_c$  of 83.3 K. The same two compacts with an additional heat treatment of twenty-four hours at 845 °C

in air, shown in Figure 10, the two times calcined material had a  $T_c$  of 104.4 K, and the three times calcined material had a  $T_c$  that was 4 K higher at 108.2 K.

## 2. BSCCO TapeCast Material

All of the powder used to make the tapecast material was calcined three times. There was a problem with the tapecast material, after thirty hours sintering, a percentage of the tapes started to curl and fracture. As the sintering time increased so did the percentage of unacceptable tapes. To alleviate the curling problem, the tapes were covered and sintered at 845 °C for thirty hours using the single ramp furnace schedule shown in Figure 3. These tapes did not curl but they did partially react with the setter plate. From information about the binder burnout rate and the Y-Ba-Cu-O system, it was decided that the tapes were to be covered and sintered at 500 to 800 °C for two hours using the double ramp furnace schedule shown in Figure 4, then uncovered and sintered for thirty hours at 845 °C. These results are shown in Table 1. The best results came from the tapes which were covered and sintered at 845 °C, but these tapes partially reacted with the setter plate.

A sintering time versus critical temperature curve in the twenty-eight to forty-eight hour single ramp sintering time range with a dot for the double ramp process of 700 °C is shown in Figure 11. The curve shows just how much higher the  $T_c$  of the double ramp process is over the single ramp process. The  $J_c$ 's of the double ramp process are twice that of the single ramp process.

## IV. Conclusions

In conclusion, to produce the uniaxially and hot pressed bulk material with the best properties the starting material should be calcined three times. Calcination work with the tapecast material still needs to be done. To fabricate uniform tapecast material, the tapes must be covered and the



double ramp method used to prevent cracking and curling. Hot pressing the bulk material before sintering allows the high  $T_c$  phase to be developed in significantly shorter time.

## References

1. Maeda, H., Y. Tanaka, M. Fukutomi and T. Asano, (1988). "A New high- $T_c$  Oxide Superconductor Without a Rare Earth Element," *Jap. J. Appl. Phys.*, vol. 27, No. 2, February, pp. L209-L210.
2. Haertling, G. H., (1990). "Development and Evaluation of Superconducting Circuit Elements," NASA Final Report, Contract No. NAG-1-820, October.
3. Haertling, G. H., (1991). "Ceramic Superconducting Components," *Ceramic Transaction*, Vol. 18
4. Reed, J. S., (1988). *Introduction to the Principles of Ceramic Processing*, John Wiley & Sons, New York.
5. Haertling, G. H., (1991). "Development of High  $T_c$  (>110 K) Bi, Tl and Y-Based Materials as Superconducting Circuit Elements," NASA Annual Report, Contract No. NAG-1-1108, June.

**Table 1** The firing schedule, process, the  $T_c$ , and the  $J_c$  of the tapecast material using the two stage ramp firing process. All of the tapes were firing at 845 °C for thirty hours.

Temp	Firing	$T_c$ (K)	$J_c$ (A/cm <sup>2</sup> )
845	Single	101.5	80.8
800	Double	99.0	46.6
700	Double	101.3	50.9
650	Double	90.8	20.1
500	Double	NS	NS

NS - Non Superconducting

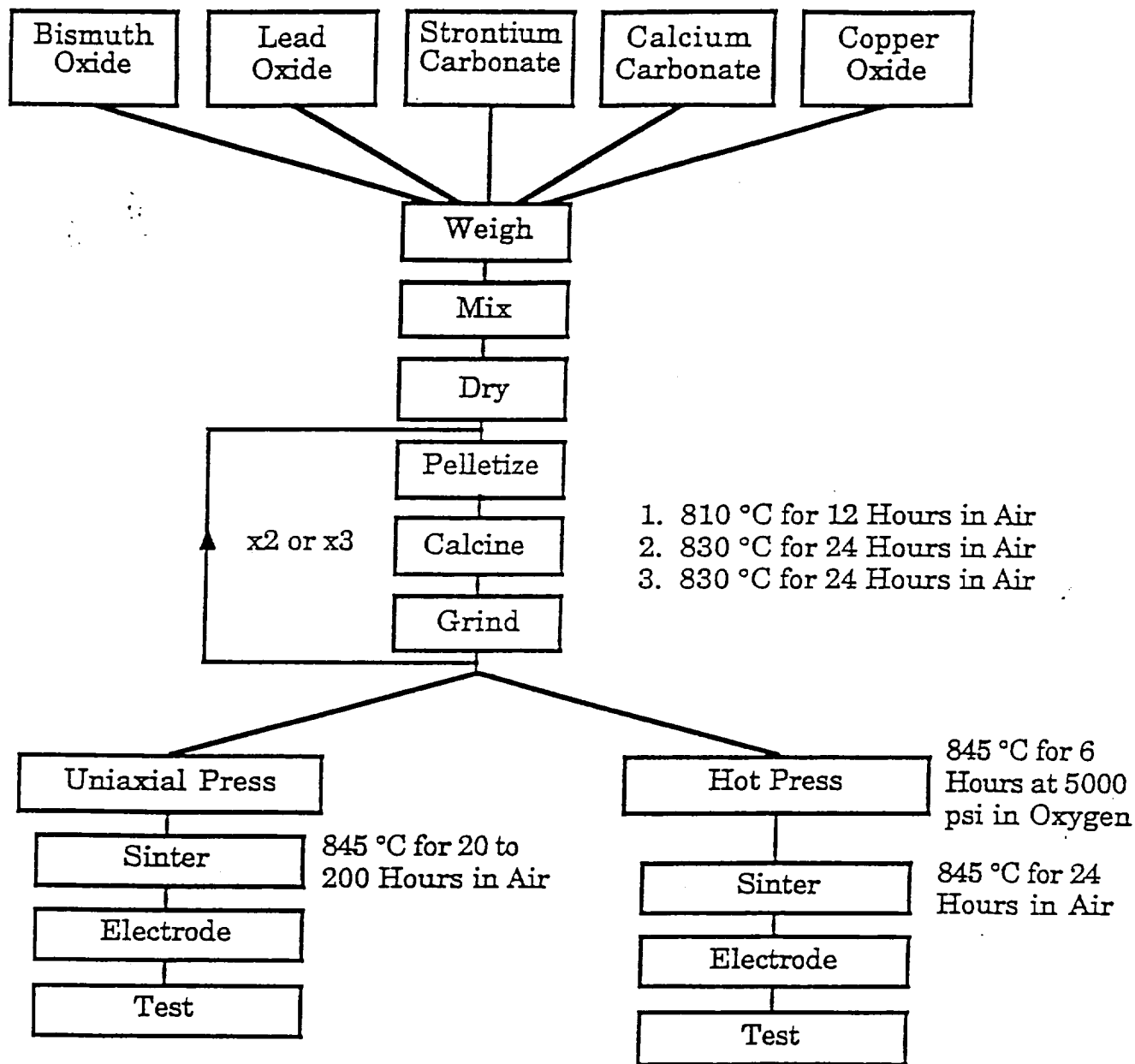

**Figure 1** Flow chart for the uniaxially and hot pressed bismuth-based materials showing the procedures used to synthesize these materials. These materials were synthesized using both two and three time calcined powder.

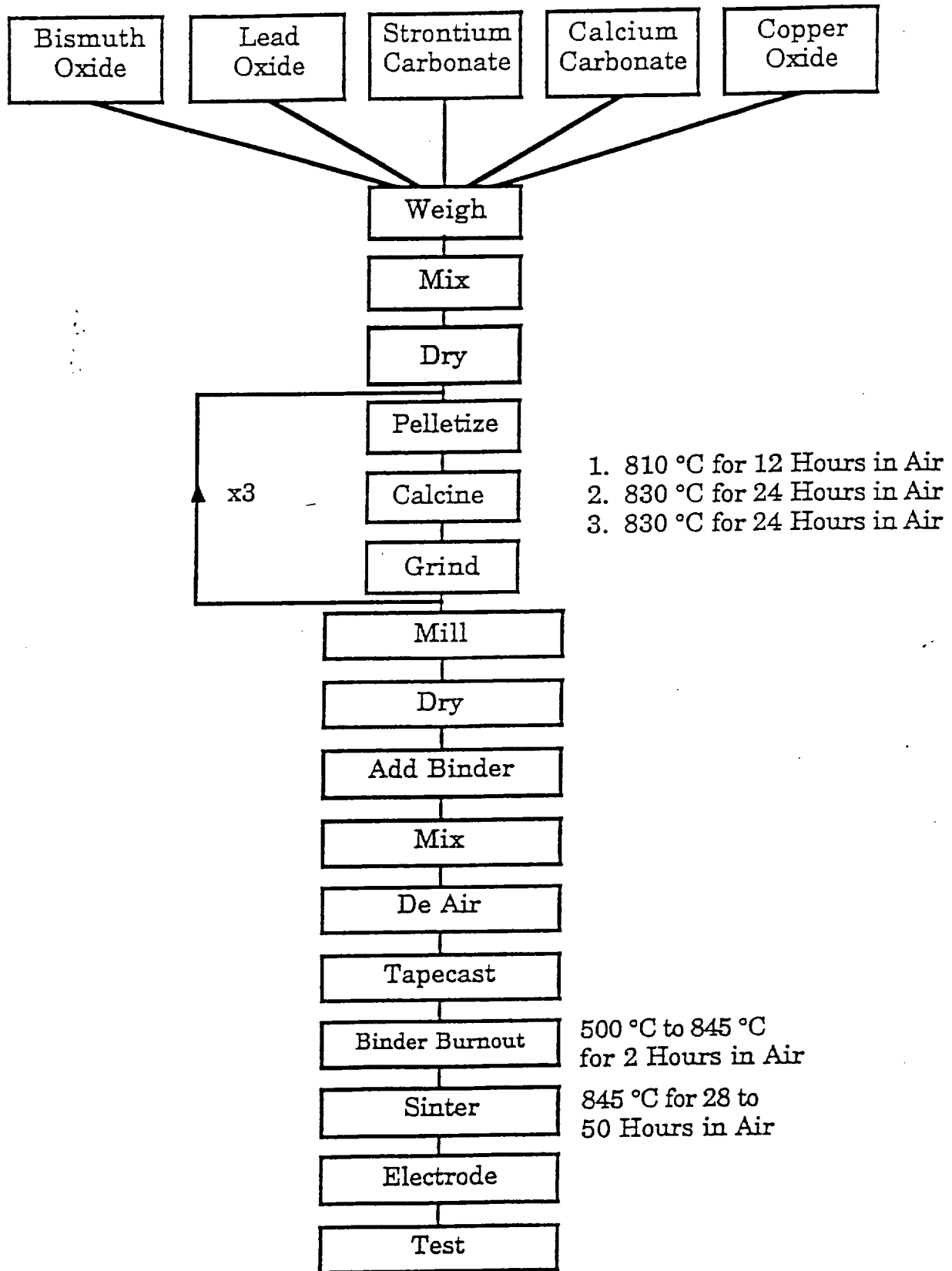

**Figure 2** Flow chart for the tapecast bismuth-based materials showing the procedures used to synthesize these materials. These materials were synthesized using three time calcined powder.

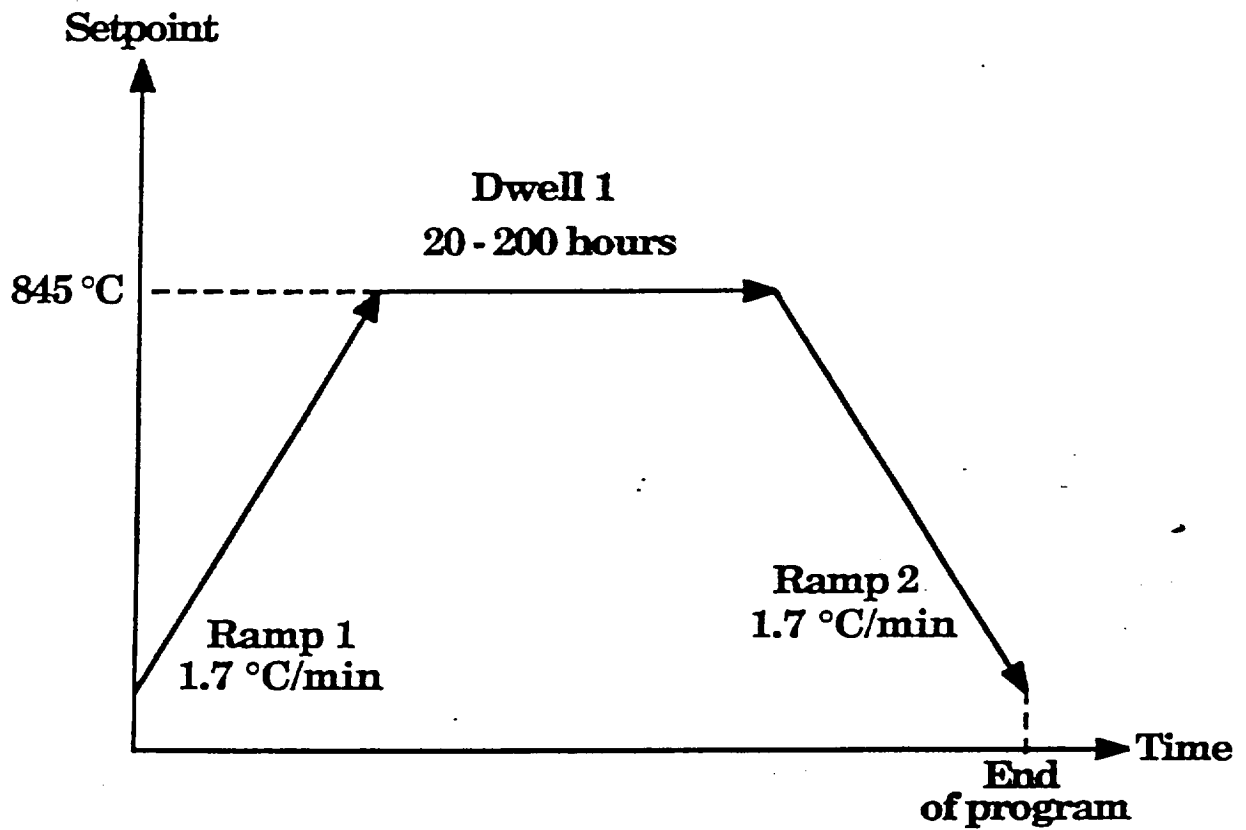

**Figure 3** The furnace schedule and operation for the bulk and single ramp tapecast bismuth-based materials.

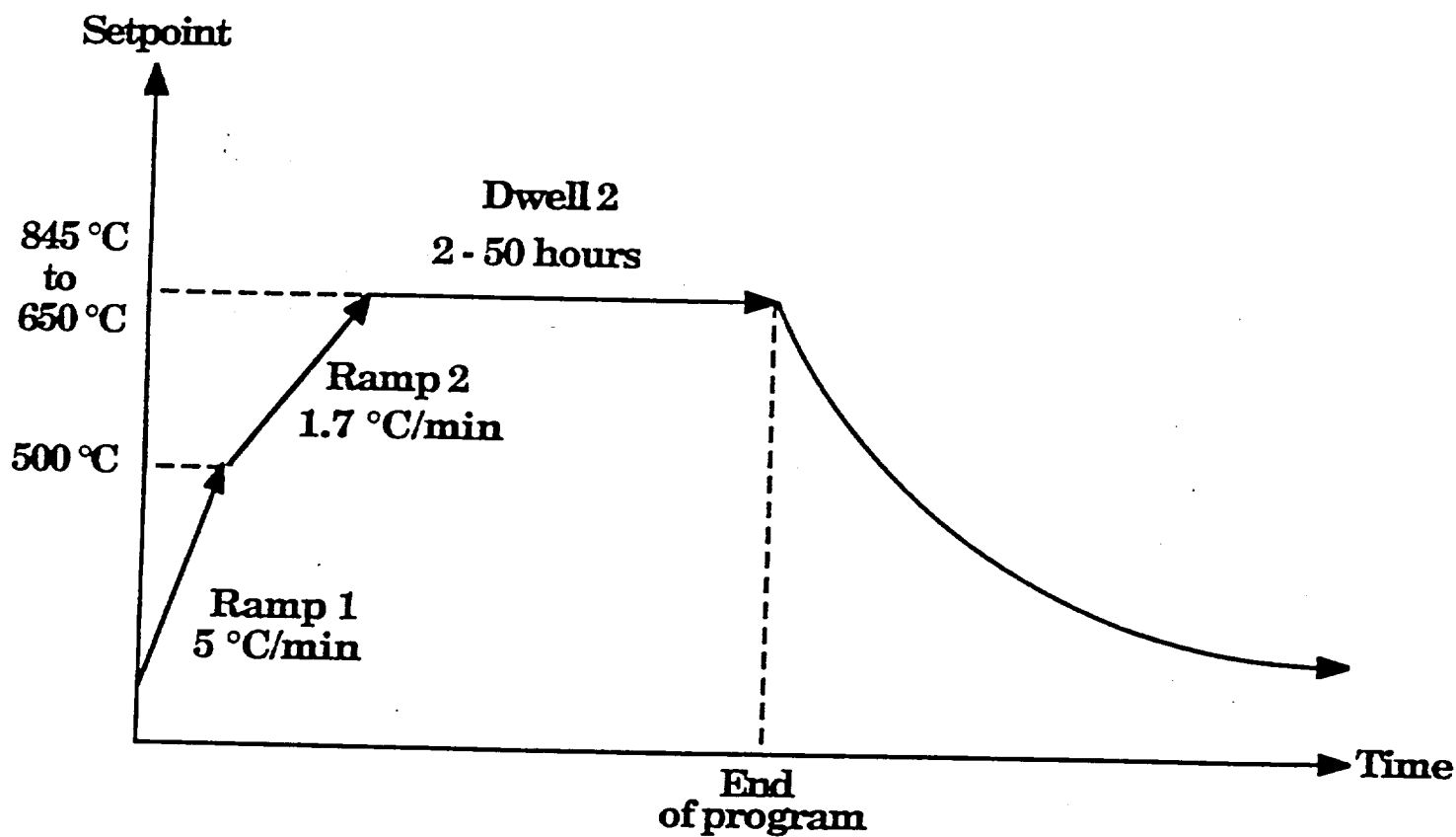

**Figure 4** The furnace schedule and operation for the double ramp tapecast bismuth-based materials.

Sample No: \_\_\_\_\_

Date: \_\_\_\_\_

Sample ID: \_\_\_\_\_

by: \_\_\_\_\_

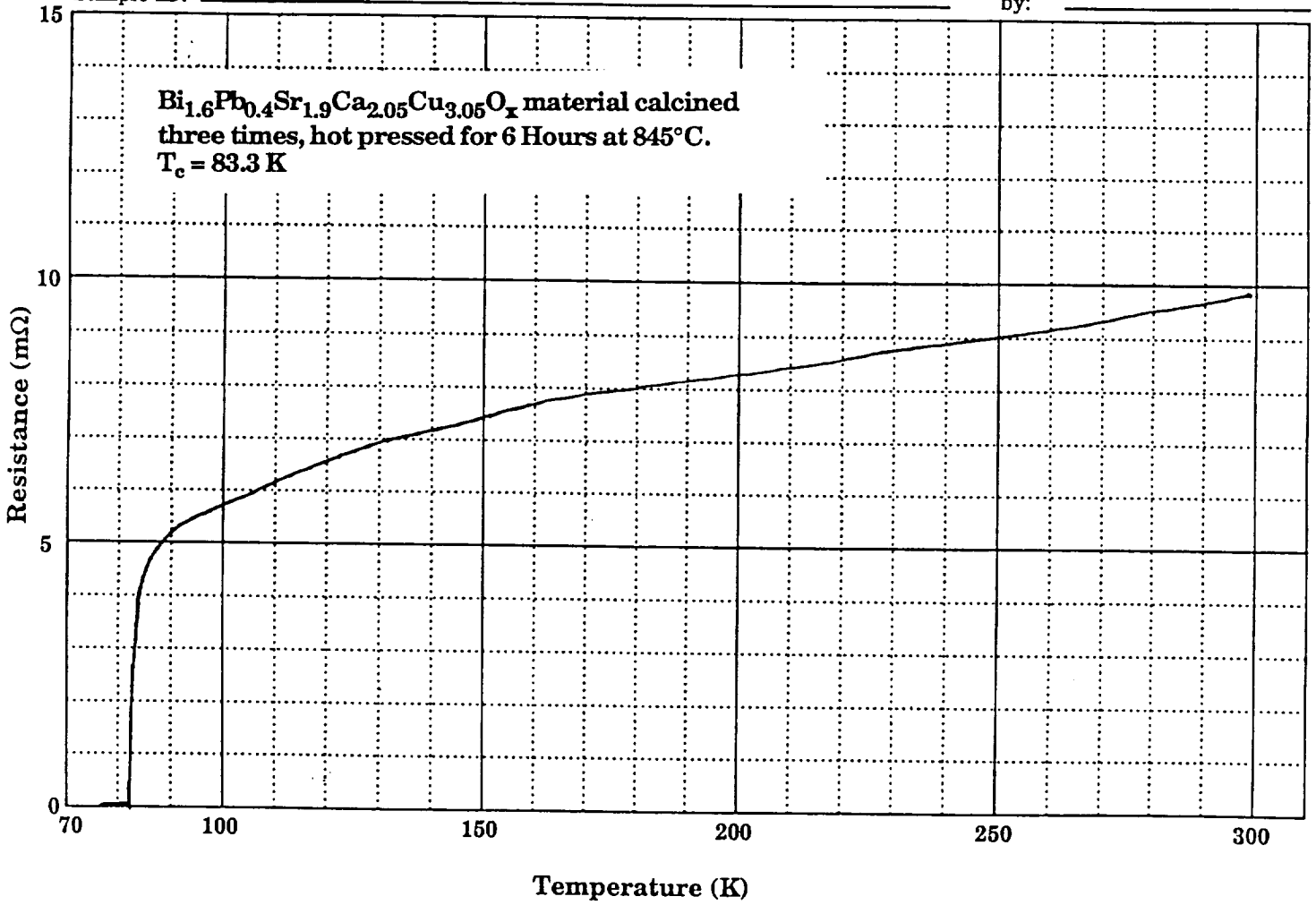

**Figure 5** Resistance versus Temperature curve for a bulk hot pressed sample with no additional heat treatment.



Sample No: \_\_\_\_\_

Date: \_\_\_\_\_

Sample ID: \_\_\_\_\_

by: \_\_\_\_\_

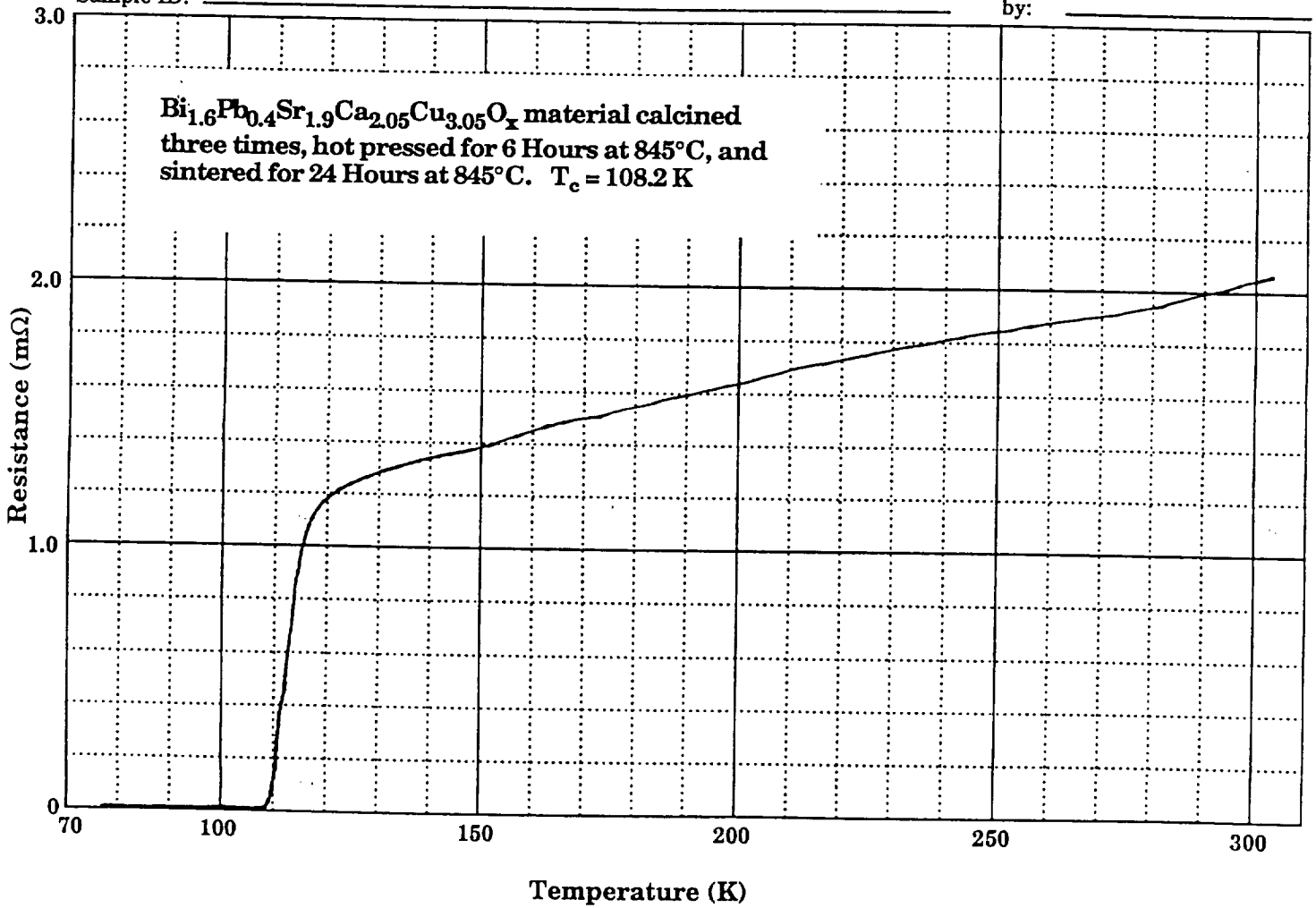

**Figure 6** Resistance versus Temperature curve for a bulk hot pressed sample with twenty-four hours additional heat treatment at 845 °C.

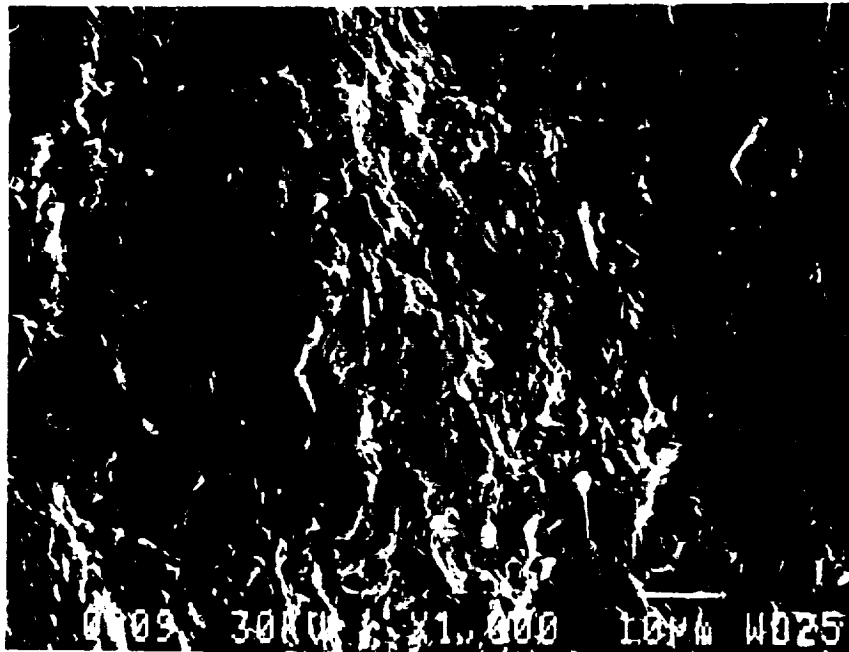

a) Hot pressed pellet with no additional heat treatment.



b) Hot pressed pellet sintered for an additional twenty-four hours in air.

**Figure 7** SEM micrographs for bulk hot pressed pellets pressed at 5000 psi for six hours at 845 ° C in oxygen.

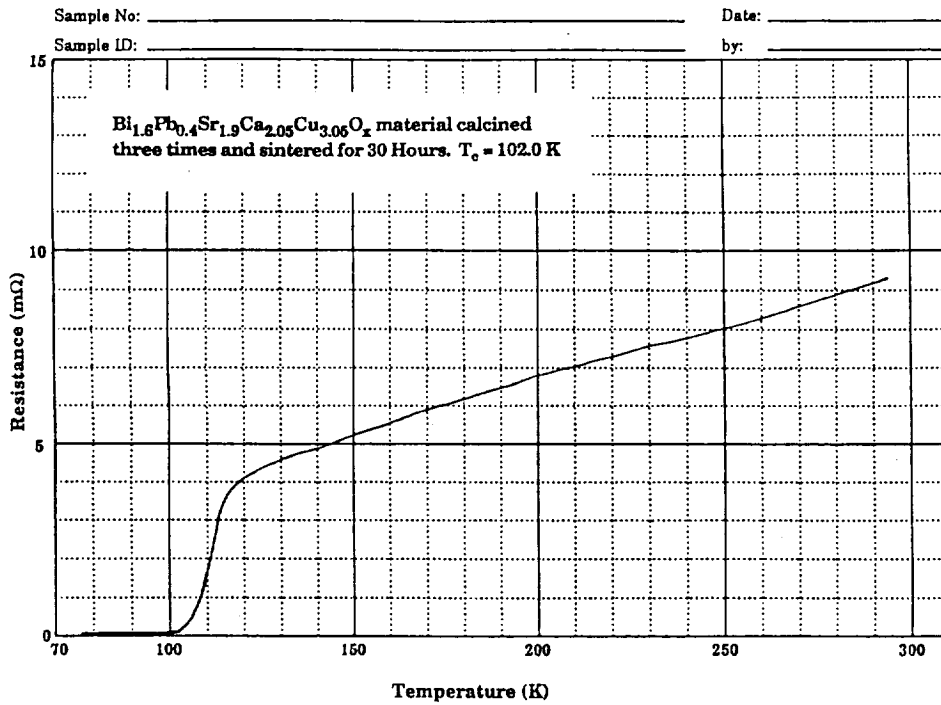

a) Uniaxially pressed pellet calcined twice. The T<sub>c</sub> is 99.1 K

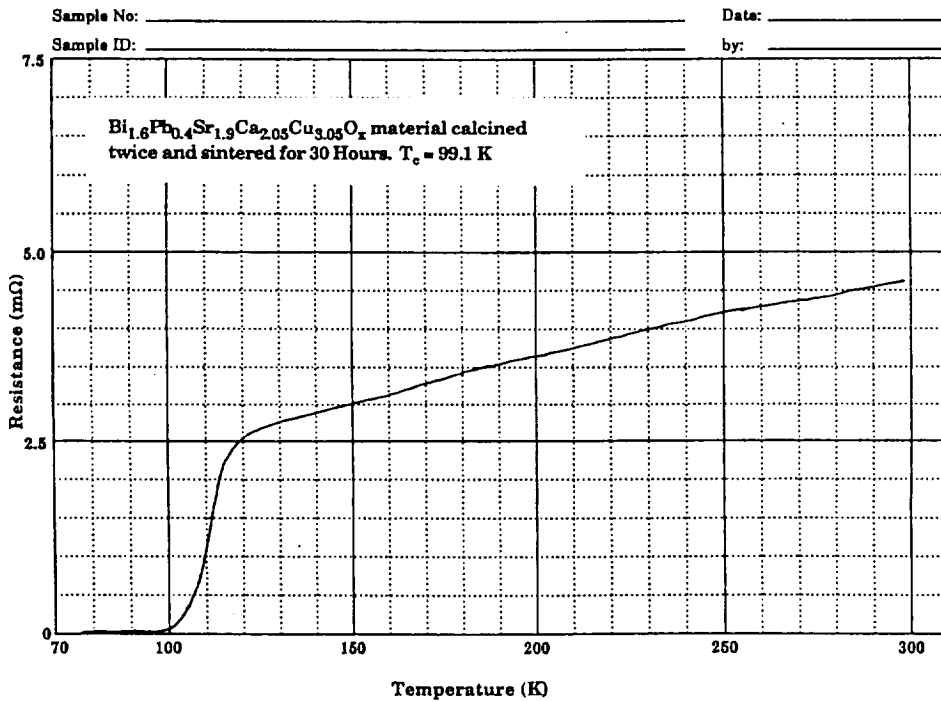

b) Uniaxially pressed pellet calcined three times. The T<sub>c</sub> is 102.0 K

**Figure 8** Resistance versus Temperature curves for a bulk samples sintered for thirty hours in air at 845 °C. They varied in number of times the material was calcined.

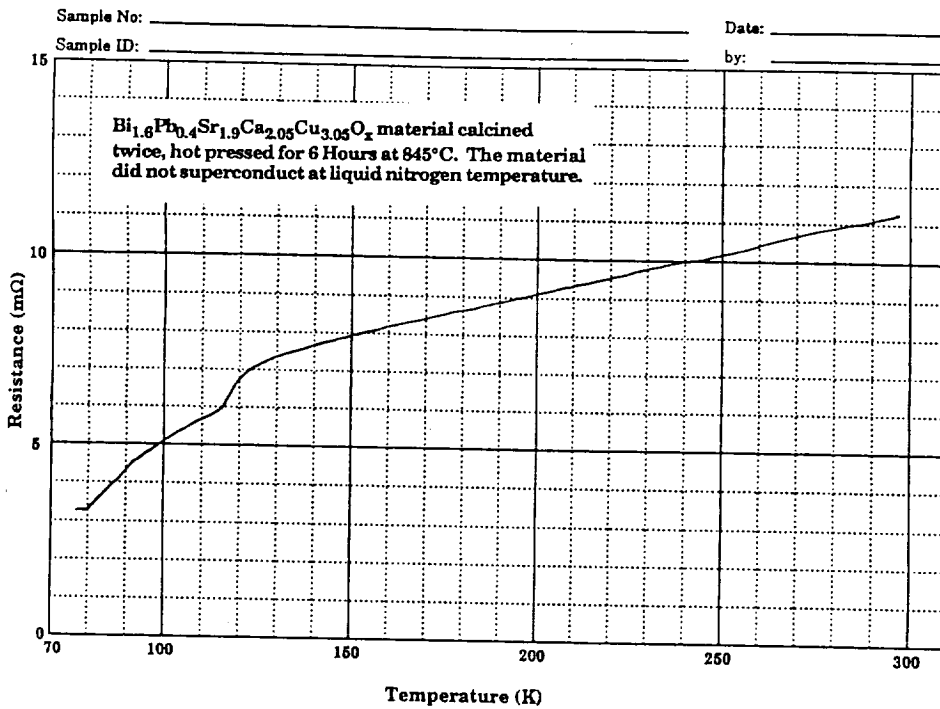

a) Hot pressed pellet with no additional heat treatment calcined twice. The Material did not superconductor.

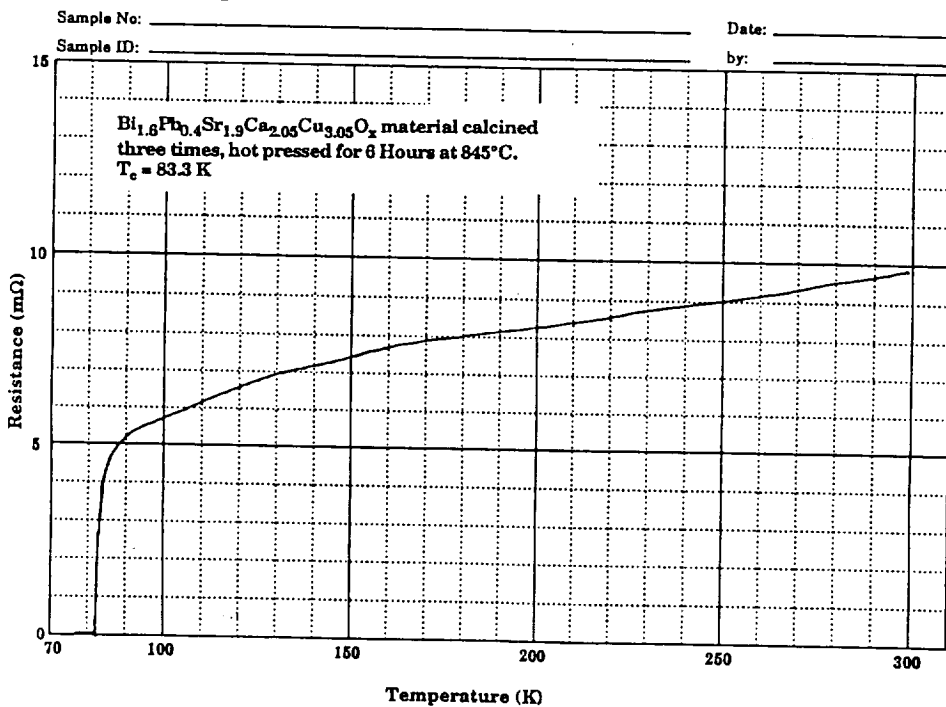

b) Hot pressed pellet with no additional heat treatment calcined three times. The  $T_c$  was 83.3 K

**Figure 9** Resistance versus Temperature curves for bulk hot pressed samples with no additional heat treatment. They varied in number of times the material was calcined.

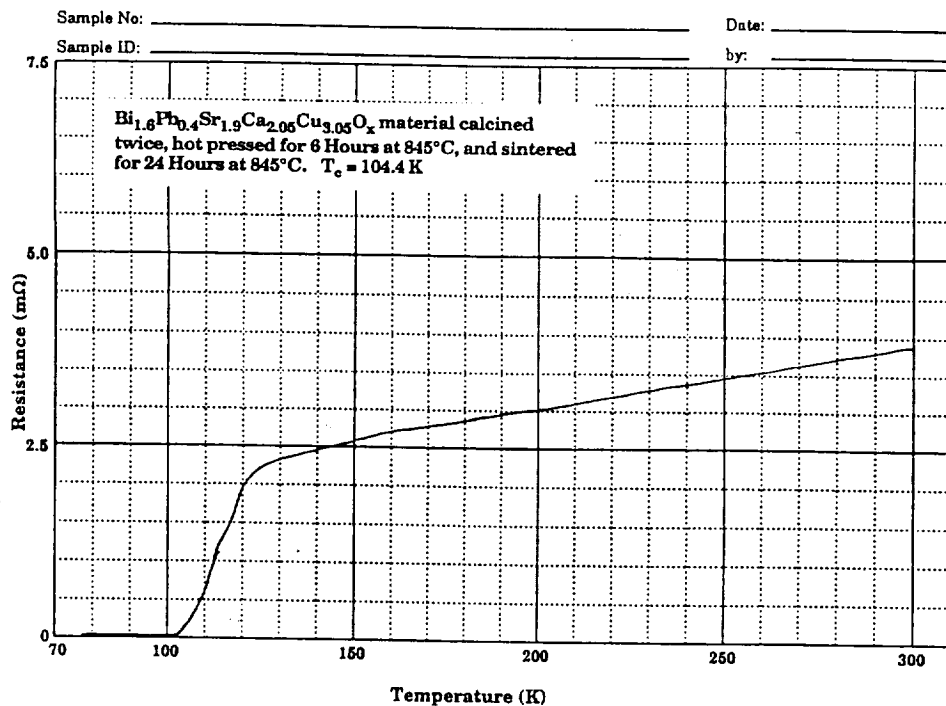

a) Hot pressed pellet with additional heat treatment calcined twice. The  $T_c$  was 104.4 K

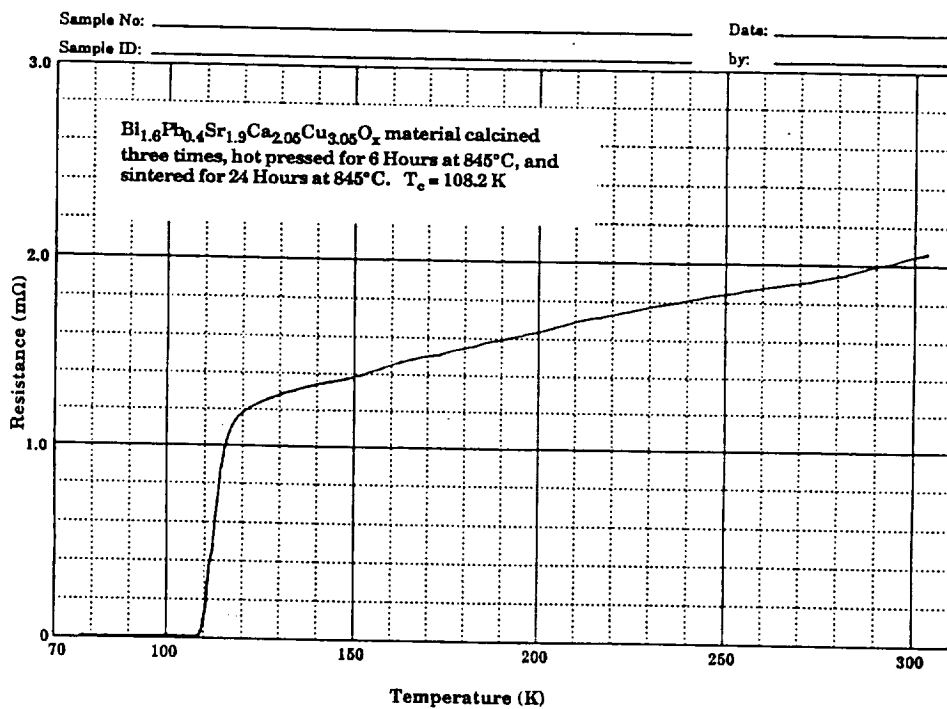

b) Hot pressed pellet with additional heat treatment calcined three times. The  $T_c$  was 108.2 K

**Figure 10** Resistance versus Temperature curves for bulk hot pressed samples with twenty-four hours additional heat treatment at  $845^\circ\text{C}$ . They varied in number of times the material was calcined.

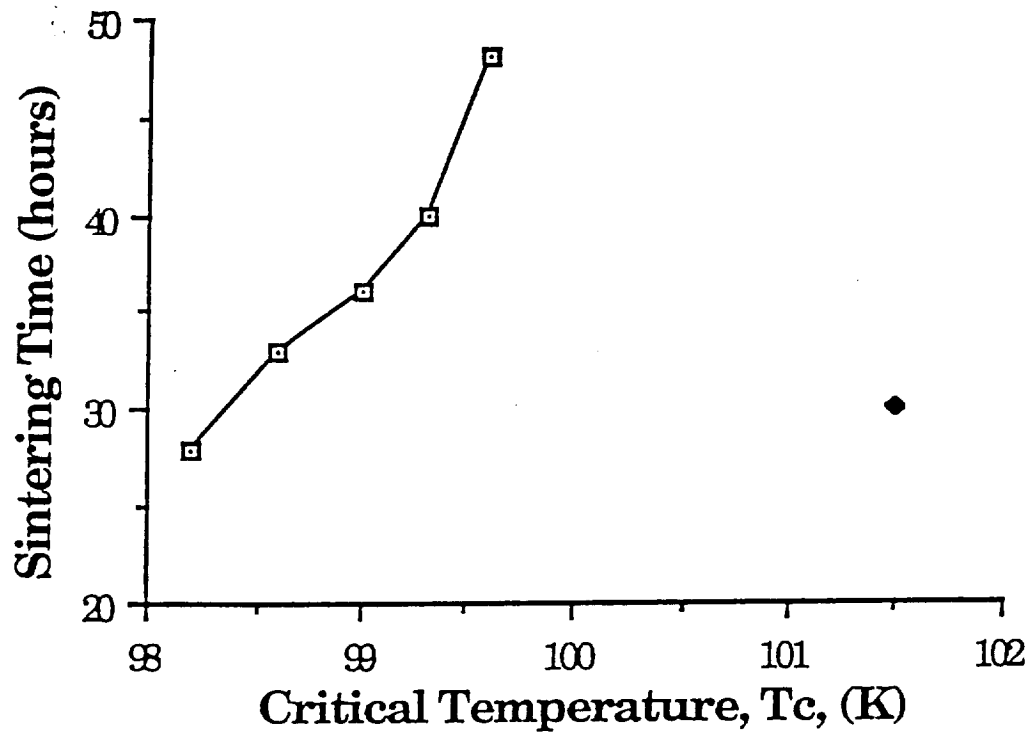

**Figure 11** Sintering Time versus Critical Temperature curve for the single ramp tapecast material with a dot for the double ramp tapecast material, showing why the double ramp process is preferred.

**Semiannual Report**

**Part II**

**Development of Ti-Based Materials**

**submitted to**

**National Aeronautics and Space Administration  
Langley Research Center**

**submitted by  
Phillip Gilmour**

**Principal Investigator  
Gene H. Haertling**

**Department of Ceramic Engineering  
Clemson University  
Contract No. NAG-1-1108  
November 1991**

## Abstract

Two studies were performed to investigate if additives can enhance the superconducting transition temperature of thallium-based superconductors with the nominal composition  $\text{Tl}_2\text{Ba}_2\text{Ca}_2\text{Cu}_3\text{O}_{10}$ . In the first study, additional data of lithium substitutions for copper was collected and found to support previous conclusions that small concentrations of lithium improve transition temperatures. Another investigation showed manganese substitutions for copper produced a deleterious effect on the transition temperature for all concentrations studied.

Thallium superconductor tapes were fabricated with the nominal composition  $\text{Tl}_2\text{Ba}_2\text{Ca}_2\text{Cu}_3\text{O}_{10}$ . A tape-cast technique was developed to improve thallium homogeneity in the ceramic. In this fabrication method, a precursor powder with the nominal composition  $\text{Tl}_2\text{Ba}_2\text{Ca}_2\text{Cu}_3\text{O}_{10}$  was mixed with a resin binder for casting tapes. The highest superconducting transition temperature found for a tape, 106.5K, was found in a ceramic with a small initial particle size and flash-fired close to the melting point.



## **Lithium Additions**

In the previous annual report,<sup>1</sup> small amounts of lithium appeared to increase the superconducting transition temperatures of thallium superconductors in a pelletized form. More data is included in this report which supports this conclusion. The experimental procedure was described in the previous report.

Figure 1 shows the change in superconducting transition temperature with increased lithium oxide additions for pellets sintered at 890°C for 30 minutes (pellets were batched to the nominal composition  $Tl_2Ba_2Ca_2Cu_3O_{10}$ ). A maximum transition temperature of 108.3K occurs for 6.7 mole percent lithium substitution for copper, corresponding to the formula  $Tl_2Ba_2Ca_2Cu_{2.8}Li_{0.2}O_{10}$ . Higher lithium concentrations reduce the transition temperature. While it was hoped lithium would act as a flux and lower the sintering temperature, thereby reducing thallium volatility, results from the previous study suggest temperatures above 880°C must be attained to produce appreciable amounts of the Tl-2223 phase. However, lithium could be added in small amounts to slightly improve the superconducting transition temperature.

## **Manganese Additions**

In an attempt to further improve upon the processing procedure and superconducting properties of thallium superconductors--with the ultimate objective of developing a reliable process for fabricating good quality Tl-superconductor tapes--manganese substitutions for copper were investigated. It was hoped that manganese would increase oxygen diffusivity while sintering yielding improved superconductor properties.

It is well-known in the capacitor industry that very small additions of manganese to perovskite-based capacitor compositions can slightly enhance densification and dramatically increase resistivity. A complete understanding of the mechanism by which manganese accomplishes this effect is not yet known. Since manganese ions can undergo changes in oxidation state relatively easily, a partial explanation may be due to enhanced anion diffusivity stemming from the ease in which manganese can change its state to accommodate oxygen/oxygen vacancy diffusion in the lattice while sintering.<sup>2</sup>

Since high-temperature superconductors contain a perovskite sublattice and anion distribution is critical in attaining high-temperature superconductors,

manganese substitutions for copper were examined. Previous papers suggest manganese additions for copper do not degrade or only slightly degrade the transition temperature.<sup>3,4</sup> However, manganese/copper substitutions in these studies were an order-of-magnitude higher than typical manganese/transition metal substitutions used in the capacitor industry.

Superconducting ceramic pellets containing manganese substitution for copper were processed by the same procedure as lithium substituted superconductors. Substitutions of manganese, in the form of  $MnO_2$ , were added in concentrations of 0, 0.47, 0.93 and 1.87 mole percent of copper in the formula  $Tl_2Ba_2Ca_2Cu_3O_{10}$ . Figure 2 shows the dependence of the superconducting transition temperature on manganese concentration. These pellets, which were sintered at 885°C for 30 minutes, show a decrease in transition temperature with increasing manganese concentration. Similarly, Figure 3 shows pellets fired at 885°C for 120 minutes also show a decrease in transition temperature with increasing manganese substitutions. Hence, it appears manganese produces a deleterious effect on the transition temperature under the conditions investigated.

## **Thallium Superconductor Tapes**

### Introduction

There is a paucity of fabrication techniques used to fabricate  $Tl_2Ba_2Ca_2Cu_3O_{10}$  or  $Tl_2Ba_2CaCu_2O_8$  tapes. Previous investigations in the literature attempt to develop thallium superconductor tapes by placing a  $Ba_2Ca_2Cu_3O_7$  precursor tape and  $Tl_2O_3$  powder (or a mixture of Tl/Ba/Ca/Cu oxides) in a hermetically sealed container.<sup>5,6</sup> Upon heating above 720°C, thallium oxide gasifies and diffuses into the precursor while the sealed container prevents thallium from seeping into the outside environment. Sheng and Hermann developed this method to reduce the thallium volatility and toxicity in a laboratory or industrial environment. Typical transition temperatures of tapes range from 100K-115K. Sheng and Hermann noted there is a large variability the transition temperature. This could be attributed to the resulting inhomogeneity which results from thallium diffusion into the precursor material or to the sensitivity of thallium superconducting compounds to processing conditions.

A different tape fabrication approach was undertaken in this study. Instead of thallium diffusing into the precursor, it was believed a solid state reaction of thallium with other precursors during sintering may lead to greater tape homogeneity and possibly improved properties and reproducibility.

#### Precursor Formation and Binder Burn-Out Procedure

Powders of  $Tl_2O_3$ ,  $BaO_2$ ,  $CuO$  and  $CaO$  were used in this study.<sup>†</sup> Initial batches of Tl-Ba-Ca-Cu-O tapes were made by mixing  $BaO_2$ ,  $CaO$ , and  $CuO$  in stoichiometric proportions to the formula  $Ba_2Ca_2Cu_3O_7$ . (This common precursor synthesis route was developed by Sheng and Hermann to produce liquid phase sintering and improve copper and alkali metal homogeneity.) The oxides were ball-milled in trichloroethylene for one hour. After drying, the powder was passed through 60 mesh, pelletized at  $8 \times 10^3$  psi, and calcined in flowing oxygen for eight hours at  $915^\circ C$ . The pellets were allowed to cool with the furnace to room temperature. A porcelain mortar and pestle was used to grind the powder until it passed through 400 mesh. This powder was calcined two more times under identical conditions for a total calcination time of 24 hours.

After the final calcination, the  $Tl_2O_3$  and  $Ba_2Ca_2Cu_3O_7$  precursor were mixed in stoichiometric amounts according to the composition  $Tl_2Ba_2Ca_2Cu_3O_{10}$ . Mixing was accomplished by ball milling the powders for 30 minutes in a ball mill. After drying, thirty five weight percent of a resin binder<sup>§</sup> was added to the powder and ball-milled for one hour. The slurry was placed in a slight vacuum for 10 minutes and allowed to sit and defoam for 20 minutes. Tape casting was performed with a single knife edge set at 50 mils. The tapes were allowed to dry for three hours on each side.

Figure 4 shows a thermogravimetric analysis profile of pure binder (solvents were removed by drying in a vacuum oven for twelve hours at  $140^\circ C$ ). The figure shows a smooth burnout over a long range of temperature until negligible amounts were left at  $550^\circ C$ . Consequently, binder was removed from the green

---

<sup>†</sup>The raw powders used were:  $Tl_2O_3$ /Malinckrodt, Lot 3800KCAM;  $BaO_2$ /Eastman Kodak Co. Lot A16A;  $CaO$ /Fisher Scientific, Lot 864342; and  $CuO$ /Fisher Scientific, Lot 901219

<sup>§</sup>The binder used was from Metoramic Sciences, Inc. B73305, Lot # 0-4824.

tapes by slowly heating (3°C/min) to 550°C and soaking for two hours. The tapes were cooled to room temperature with the furnace.

After removing from the furnace it was noticed that the tape coloration changed from black before burnout to dark brown after binder removal. Also the tapes "feathered out" making the tapes extremely delicate, porous and unusable. Figure 5 shows an SEM photomicrograph of the tape after binder removal. At first it was not certain what caused the tape feathering resulting in the channel-like structure in the SEM photomicrograph. Ramp rates, soak times, and soak temperatures were varied; however, the final "feathery" form of the burnt-out tapes always occurred.

It was noticed the tapes started to feather at approximately 200°C. As shown in Figure 4, this is approximately the same temperature where the binder begins to leave the system. To examine binder/powder interactions, two tapes consisting of Tl<sub>2</sub>O<sub>3</sub>/binder and Ba<sub>2</sub>Ca<sub>2</sub>Cu<sub>3</sub>O<sub>7</sub>/binder were cast. Burnt-out tapes of Ba<sub>2</sub>Ca<sub>2</sub>Cu<sub>3</sub>O<sub>7</sub> were relatively strong with little curling or warping. However upon opening the furnace door at 200°C to inspect the Tl<sub>2</sub>O<sub>3</sub> tapes, a dark-brown gas emanated from the furnace. After the furnace was cooled, the only evidence left of the tapes was the dark-brown discoloration of the setter plate and furnace interior.

Evidently the binder reacted with Tl<sub>2</sub>O<sub>3</sub>. Thallic oxide reduces to thallos oxide according to the reaction:

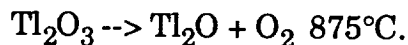

The low melting point product is responsible for the volatility of the thallium compounds and difficulty in processing. Apparently when binder begins to leave the tape at ~200°C, the organics reduce Tl<sub>2</sub>O<sub>3</sub> at a much lower temperature and volatile thallos oxide leaves the system. X-ray diffraction patterns shown in Figure 6 suggest burnt-out tapes do not contain significant amounts of Tl<sub>2</sub>O<sub>3</sub>, Tl<sub>2</sub>O, or various forms of Tl-hydroxides or carbonates. The consequent thallium loss and tape feathering does not allow this procedure to be utilized to develop Tl-superconducting tapes.

To reduce thallium volatility during binder burnout, thallium was incorporated directly into the lattice before tape casting. This was done by preparing a Ba<sub>2</sub>Ca<sub>2</sub>Cu<sub>3</sub>O<sub>7</sub> precursor according to the previously mentioned procedure. After the final calcination Tl<sub>2</sub>O<sub>3</sub> was added in stoichiometric proportions and milled for one hour. Subsequently, the powders were pelletized at a pressure of 8,000 psi, wrapped in silver foil, and presintered by flash-firing in

flowing oxygen at 840°C or 890°C for three hours (presintering will be defined as firing close to the sintering temperature in order to incorporate thallium into the superconductor structure prior to binder addition). The pellets were ground in a mortar and pestle and passed through 60 or 400 mesh. The binder mixing and tape casting was similar to the above-mentioned procedure.

A slow ramp rate of ~3°C/min to 550°C with a 90 minute soak resulted in relatively strong tapes which were not feathered but bowed. Ramp rates of ~12°C/min resulted in tapes which were flat and warped. Figure 7 illustrates the difference in microstructure of burnt-out tapes at ramp rates of 2°C/min and 12°C/min. Tapes burnt-out at the slower ramp rate show a relatively uniform microstructure. However, the tapes with a rapid burn-out rate produced regions of densely-packed grains; the density variation of these burnt-out tapes would account for tape distortion. The bowing problem at slower burnout rates was solved by pinning the tape ends with zirconia setters. Subsequent processing used the slower ramp rates for binder burnout.

After binder burnout, the tapes were carefully wrapped in silver foil and placed on a zirconia setter plate. Tapes were flash-fired in flowing oxygen at 885°C for times ranging from 30 minutes to 120 minutes. Silver paste electrodes were fired on the tapes at 600°C and allowed to cool with the furnace.

### Superconductor Tape Results

Figure 8 shows tapes which were presintered at 840°C and had a relatively coarse grain size before sintering (powder passed through 60 mesh before adding binder) did not exhibit zero resistance at liquid nitrogen temperature. In fact, sintering for only 30 minutes produced semiconducting behavior throughout the temperature range studied. As evident in Figure 9, tapes which had finer grain size before sintering (powder passed through 400 mesh before adding binder) exhibited significantly better properties: transition temperatures rose from nonsuperconducting at liquid nitrogen temperatures to 97.3K for 120 minute soak time. Microstructure of tapes fired at 890°C for 30 minutes is shown in Figure 10. The tape of the powder which was passed through 400 mesh shows a much finer, more uniform microstructure than the tape which had powder passed through 60 mesh.

Tapes which were presintered at 890°C showed a similar dependence on grain size. Figures 11 and 12 show tapes with smaller initial grain size yielded higher transition temperatures. The smallest grain size tape with the longest

soak time resulted in the highest transition temperature, 106.5K, found in this preliminary investigation. The SEM photomicrograph shown in Figure 13 shows microstructure found in the 106.5K sample consists of long rectangular grains. This is indicative of the presence of the Tl-2212 phase in the sample--for reference, a more acicular morphology is indicative of the higher transition Tl-2223 phase.

While this investigation has produced tapes with transition temperatures in the range reported in the literature, it is believed modifications in precursor stoichiometry, namely thallium concentration, and presintering conditions will yield improved tapes. It appears the most significant problem which must be overcome is diffusion of the silver into the superconductor in order to fabricate long, uniform tapes for the SAFIRE project. Changes in sintering conditions and the silver wrapping could reduce or prevent this problem.

## **Summary**

1. Additional data was collected to augment previous investigations of lithium substitutions for copper. Below 6.7 mole percent substitutions, lithium oxide enhanced the superconducting transition temperature. Above this concentration, transition temperature decreased with lithium additions.

2. Manganese substitutions for copper reduced the transition temperature for all manganese concentrations investigated.

3. Thick films were fabricated.

a) Thallium had to be incorporated into a superconducting structure before mixing with binder to prevent appreciable thallium loss during binder burnout.

b) Finer precursor powders mixed with binder resulted in higher superconducting transition temperatures.

c) Presintering at 890°C yielded higher transition temperatures than presintering at 840°C.

d) Similar to the results found in the previous investigations with ceramic pellets, longer soak times generally yielded higher transition temperatures under the conditions investigated.

## References

1. G. Haertling, "Development of High  $T_c$  (>110K) Bi, Tl, and Y-Based Materials as Superconducting Circuit Elements," NASA Annual Report, Contract No. NAG-1-1108, June 28, 1991.
2. P. C. Gilmour, "The Effect of Manganese Additions on the Stoichiometry and Resistivity of a Lead-Iron-Niobate Ceramic," M.S. Thesis, The Pennsylvania State University, 1987.
3. P. Strobel, C. Paulson, and J. L. Tholence, "Superconducting Properties of Substituted  $\text{YBa}_2\text{Cu}_{3(1-x)}\text{M}_{3x}\text{O}_{7-\delta}$ ," *Solid State. Commun.* **65**, 585-589 (1988).
4. Y. Ying-Chang, Z. Yuan-Bo, Y. Wei-Chun, Y. Ji-Lian, Z. Bui-Sheng, Z. Hui-Ming, D. Yong-Fan, J. Lan, and Y. Chun-Tang, "Substitution Effects and Neutron Diffraction Study of  $\text{YBa}_2(\text{Cu}_{0.95}\text{M}_{0.05})_3\text{O}_{7-\delta}$ ," *Acta Phys. Sin.* **39**, 111-118 (1990).
5. Z. Z. Sheng, L. Sheng, H. M. Su, and A. M. Hermann, "Tl<sub>2</sub>O<sub>3</sub> Vapor Process of Making Tl-Ba-Ca-Cu-O Superconductors," *Appl. Phys. Lett.* **53**, 2686-2688 (1988).
6. R. Sugise, M. Hirabayashi, N. Terada, M. Jo, F. Kawashima, and H. Ihara, "Preparation of Tl<sub>2</sub>Ba<sub>2</sub>Ca<sub>2</sub>Cu<sub>3</sub>O<sub>y</sub> Thick Films from Ba-Ca-Cu-O Films," *Japan. J. Appl. Phys.* **27**, L2314-2316 (1988).



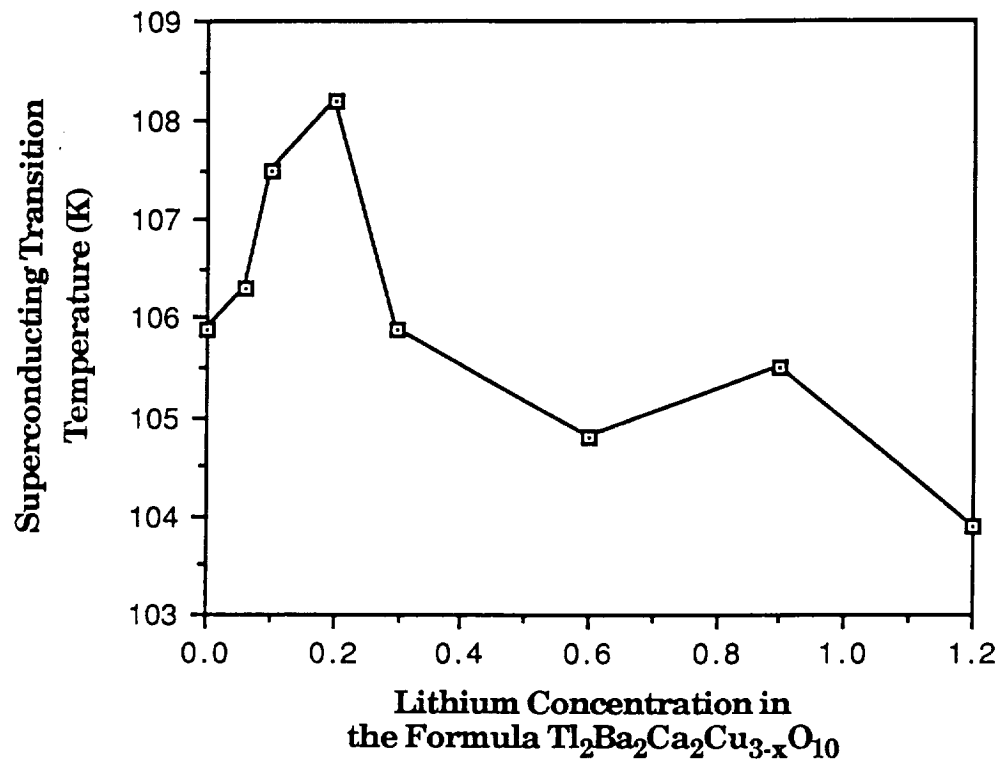

**Figure 1**

Superconducting Transition Temperature as a Function of Lithium Concentration. Flash-Fired at 890°C for 30 Minutes.

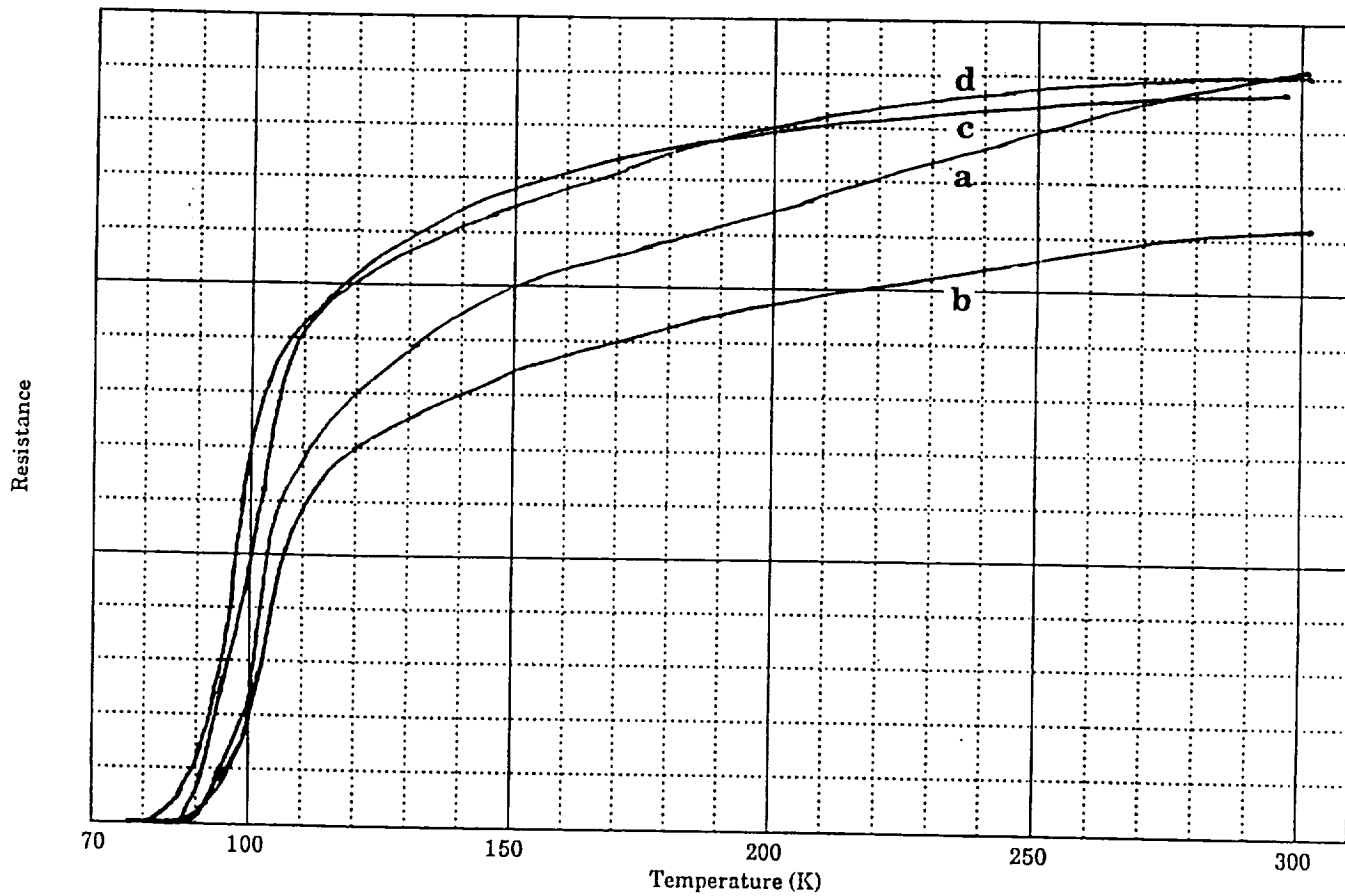

**Figure 2**

Resistance as a Function of Temperature for Ceramic Pellets with Various Manganese Substitutions. Flash-Fired at 885°C for 30 Minutes.

- a) 0 mole percent Mn for Cu ( $T_c=88.7K$ )
- b) 0.47 mole percent Mn for Cu ( $T_c=86.3K$ )
- c) 0.93 mole percent Mn for Cu ( $T_c=87.3K$ )
- d) 1.87 mole percent Mn for Cu ( $T_c=81.6K$ )

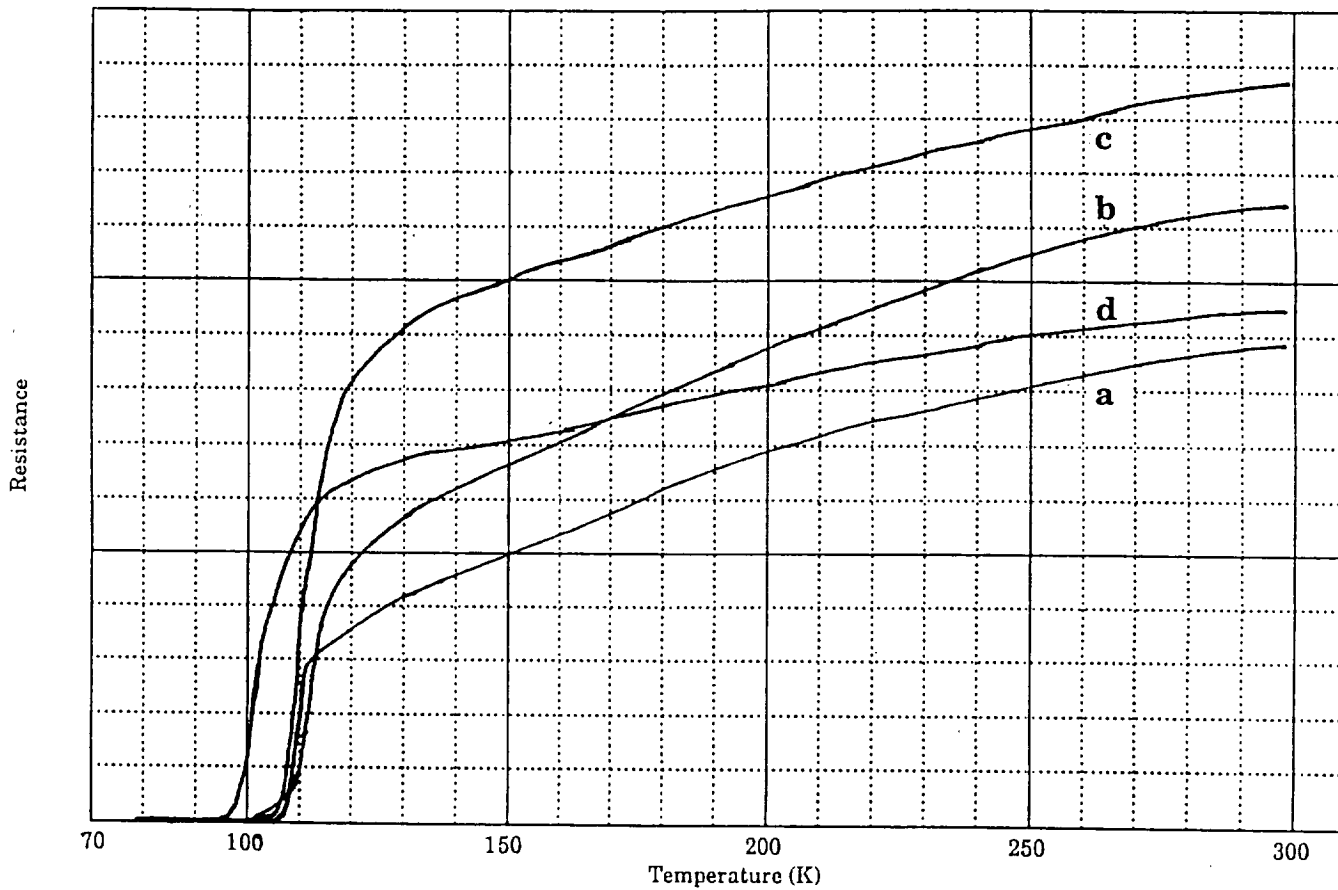

**Figure 3**

Resistance as a Function of Temperature for Ceramic Pellets with Various Manganese Substitutions. Flash-Fired at 885°C for 120 Minutes.

- a) 0 mole percent Mn for Cu ( $T_c=108.0\text{K}$ )
- b) 0.47 mole percent Mn for Cu ( $T_c=101.3\text{K}$ )
- c) 0.93 mole percent Mn for Cu ( $T_c=105.7\text{K}$ )
- d) 1.87 mole percent Mn for Cu ( $T_c=97.4\text{K}$ )

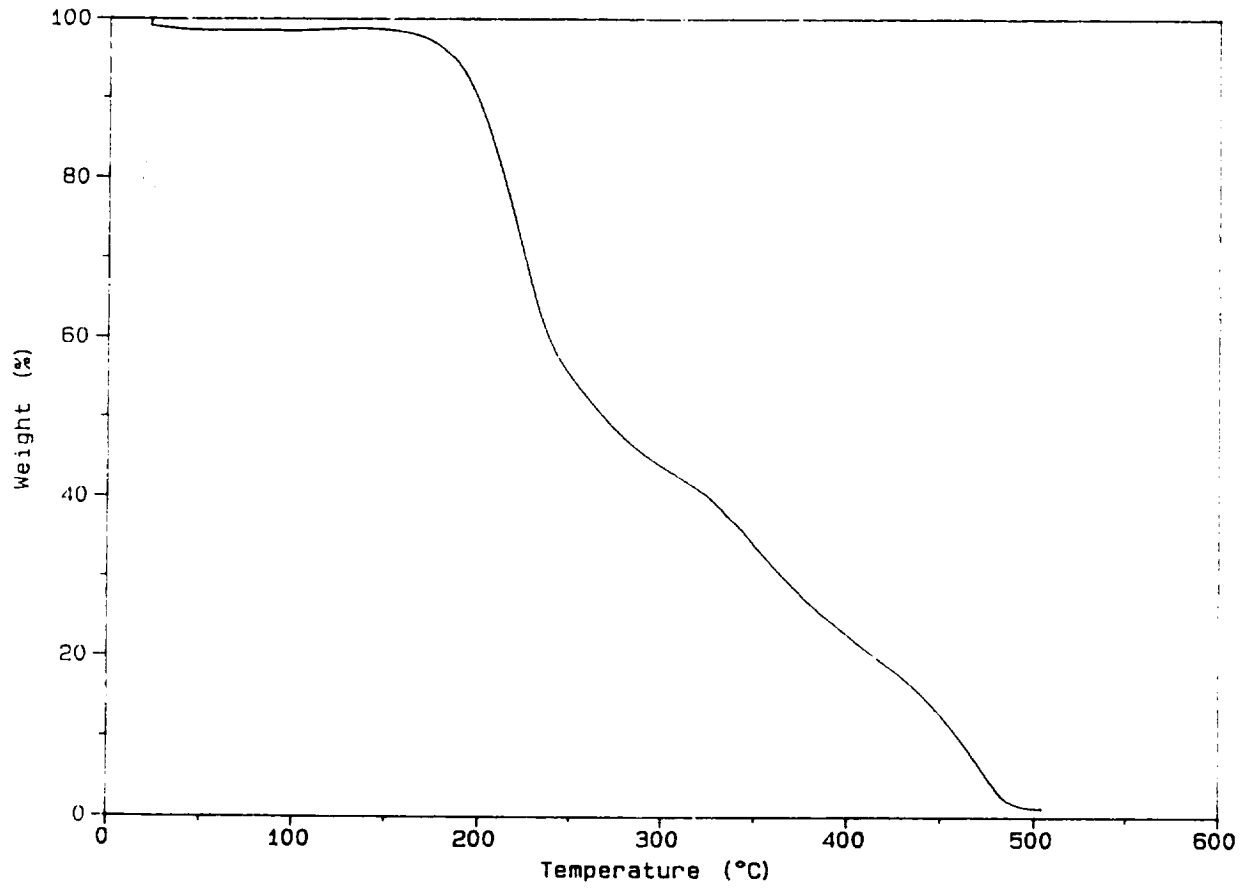

**Figure 4**

Thermogravimetric Analysis of Binder Used for Tape Casting.  
Air Purged-Rate 1°C/min.

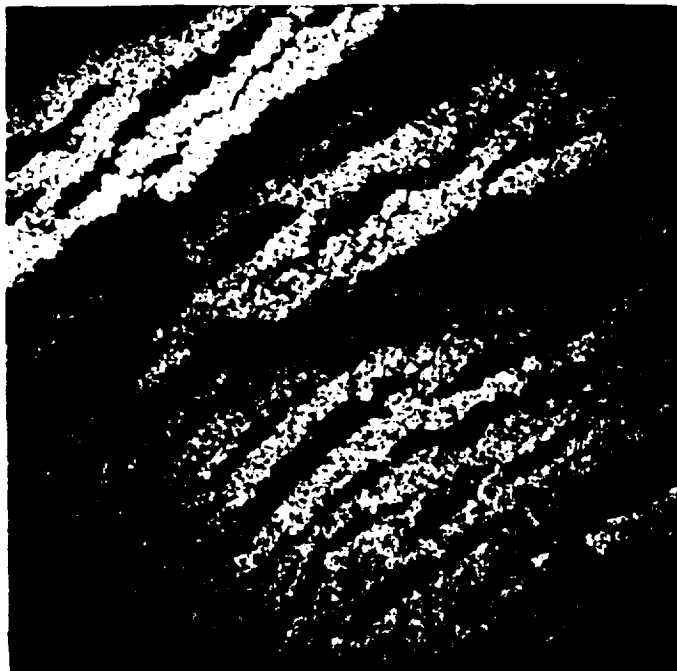
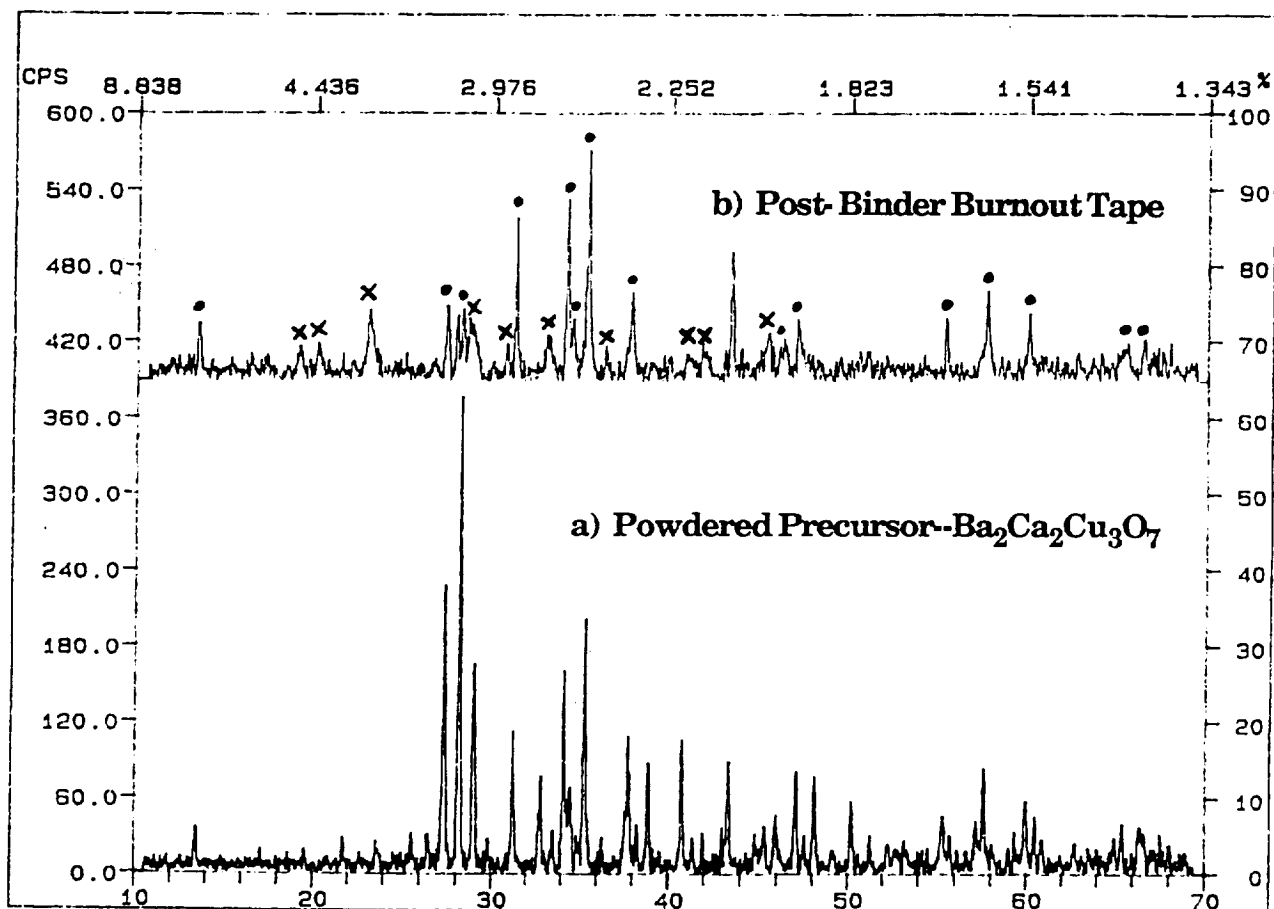

**Figure 5**

SEM Photomicrograph of a Post-Binder Burnout Tape  
Powders Mixed with Binder:  $\text{Tl}_2\text{O}_3$  and  $\text{Ba}_2\text{Ca}_2\text{Cu}_3\text{O}_7$   
(sieved through 60 mesh)

Ramp:  $5^\circ\text{C}/\text{min}$ ,  $550^\circ\text{C}$  Max., One Hour Soak.

**400X**



**Figure 6**

X-Ray Diffraction Patterns

a) Powdered Precursor Fired at 910°C for 24 Hours.--  
powder with the nominal composition Ba<sub>2</sub>Ca<sub>2</sub>Cu<sub>3</sub>O<sub>7</sub>

b) Post-Binder Burnout Tape--  
precursor powders in the tape included Tl<sub>2</sub>O<sub>3</sub> and Ba<sub>2</sub>Ca<sub>2</sub>Cu<sub>3</sub>O<sub>7</sub>

(Note: No Identifiable Thallium Oxides, Hydroxides,  
or Carbonates were Present in the Post-Binder Burnout Tape.)

- Denotes Peaks Found in Precursor
- x Denotes Unidentified Peaks.

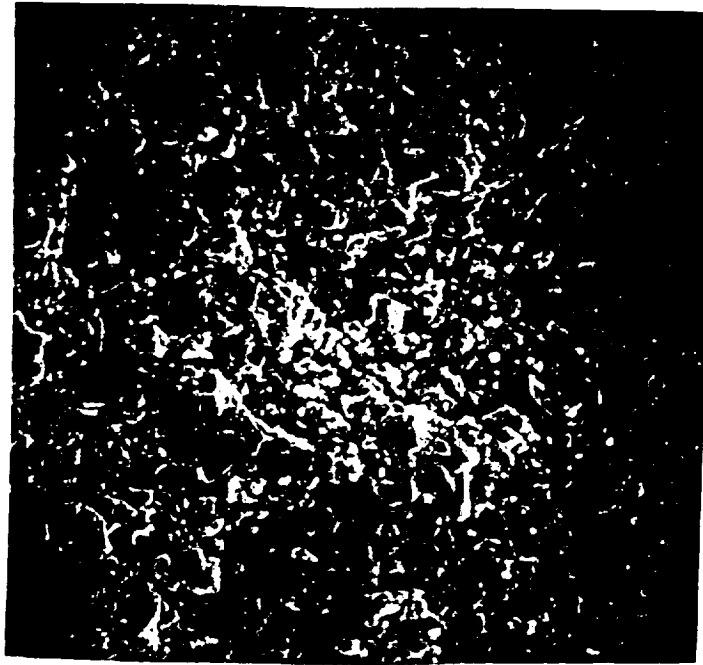

a) Ramp 2°C/min to 550°C. Soak for Two Hours.

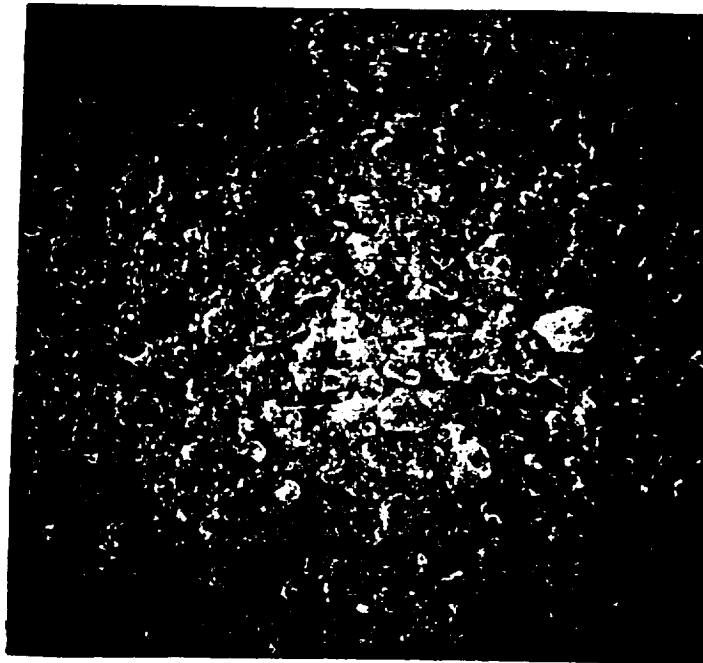

b) Ramp 12°C/min to 550°C. Soak for Two Hours.

**Figure 7**

SEM Photomicrographs of Post-Binder Burnout Tapes.  
Nominal Composition of Precursor Powder:  $\text{Tl}_2\text{Ba}_2\text{Ca}_2\text{Cu}_3\text{O}_{10}$   
200X

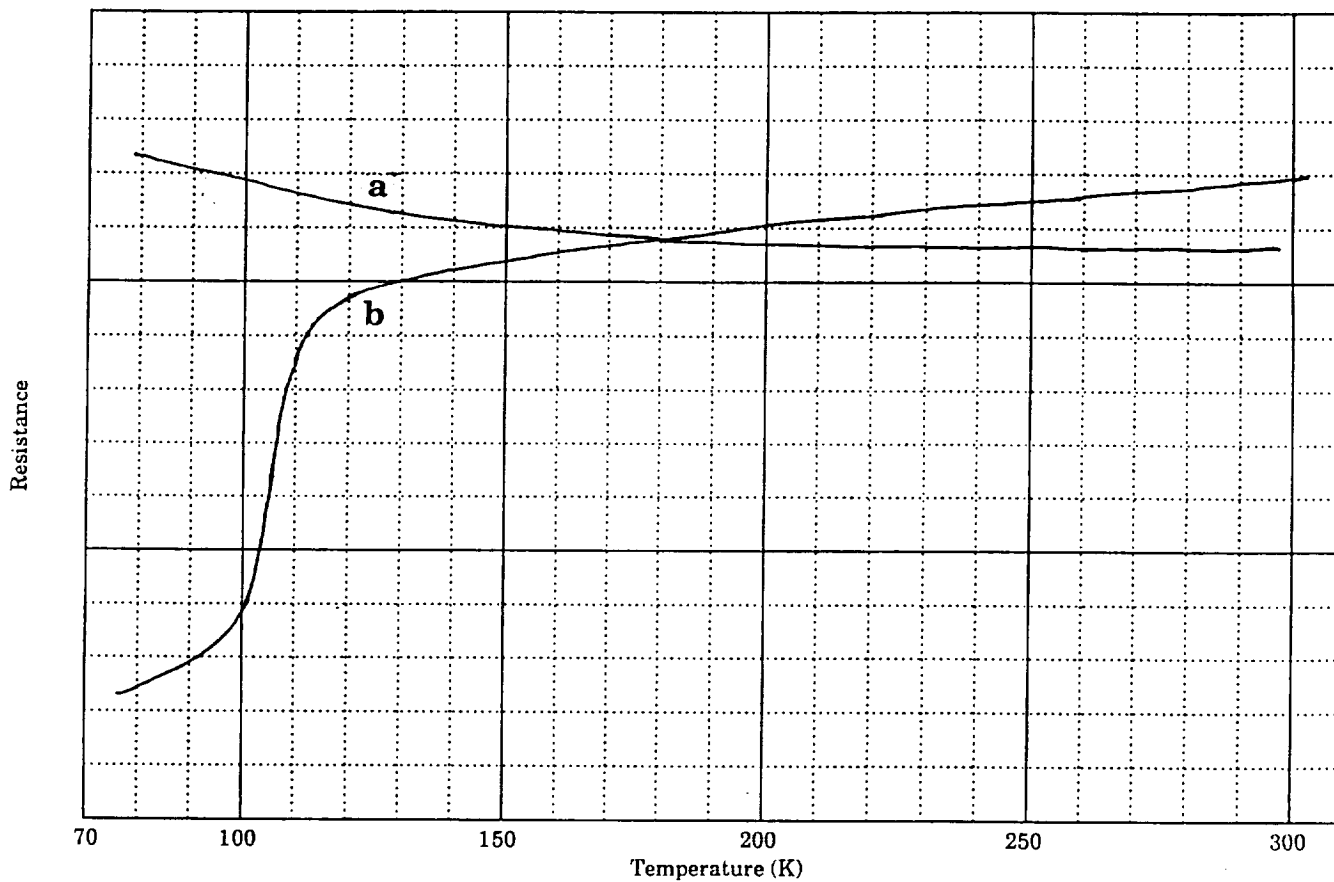

**Figure 8**

Resistance as a Function of Temperature for Ceramic Tapes.  
 Nominal Composition of Precursor Powder:  $\text{Tl}_2\text{Ba}_2\text{Ca}_2\text{Cu}_3\text{O}_{10}$   
 840°C Presinter--Sieved through 60 mesh  
 a) 30 Minute Soak at 890°C (Nonsuperconducting at 77.7K)  
 b) 60 Minute Soak at 890°C (Nonsuperconducting at 77.7K)



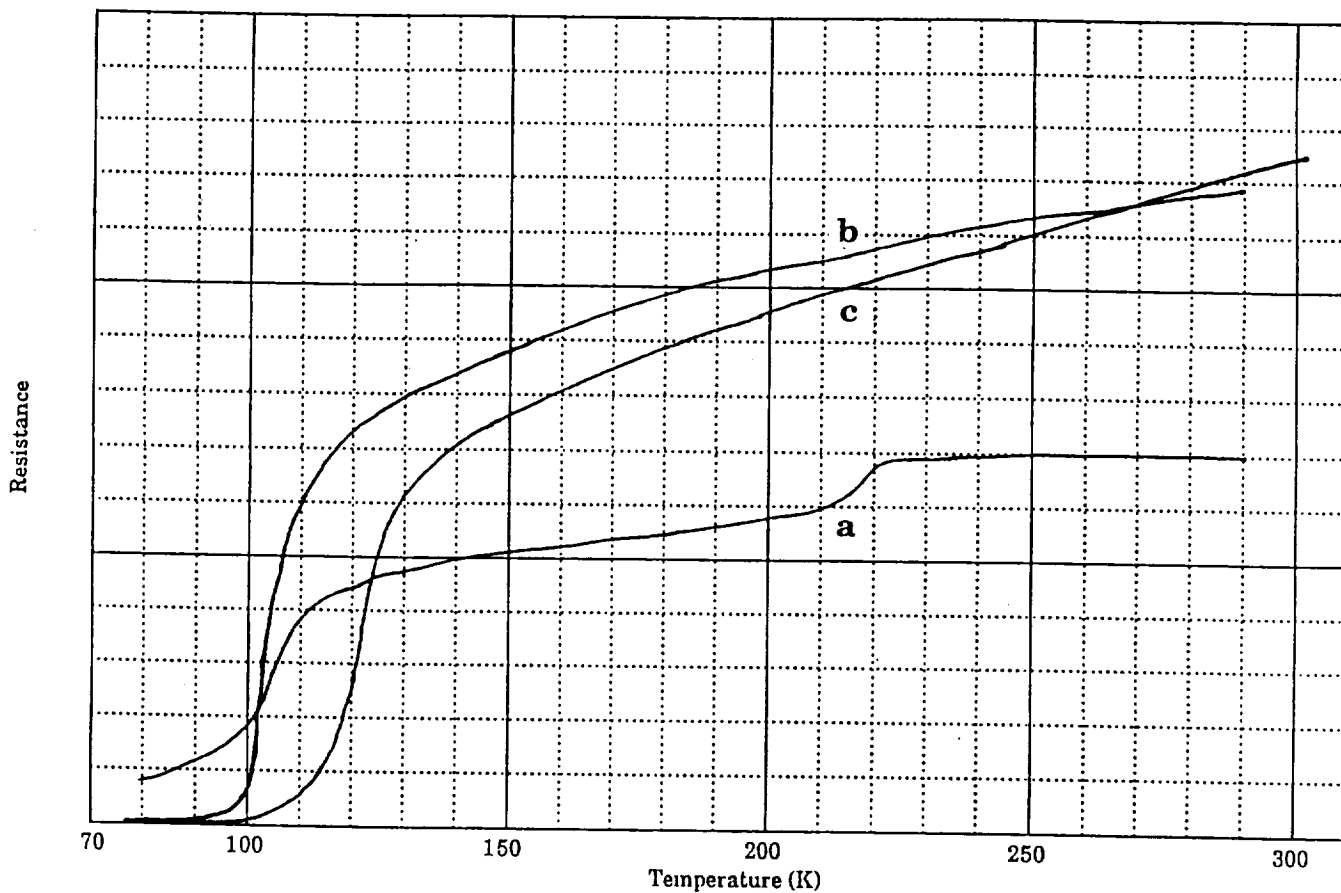

**Figure 9**

Resistance as a Function of Temperature for Ceramic Tapes.  
 Nominal Composition of Precursor Powder:  $\text{Tl}_2\text{Ba}_2\text{Ca}_2\text{Cu}_3\text{O}_{10}$

840°C Presinter--Sieved through 400 mesh

a) 30 Minute Soak at 890°C (Nonsuperconducting at 77.7K)

b) 60 Minute Soak at 890°C (Nonsuperconducting at 77.7K)

c) 120 Minute Soak at 890°C ( $T_c = 97.3\text{K}$  at 1 mA)

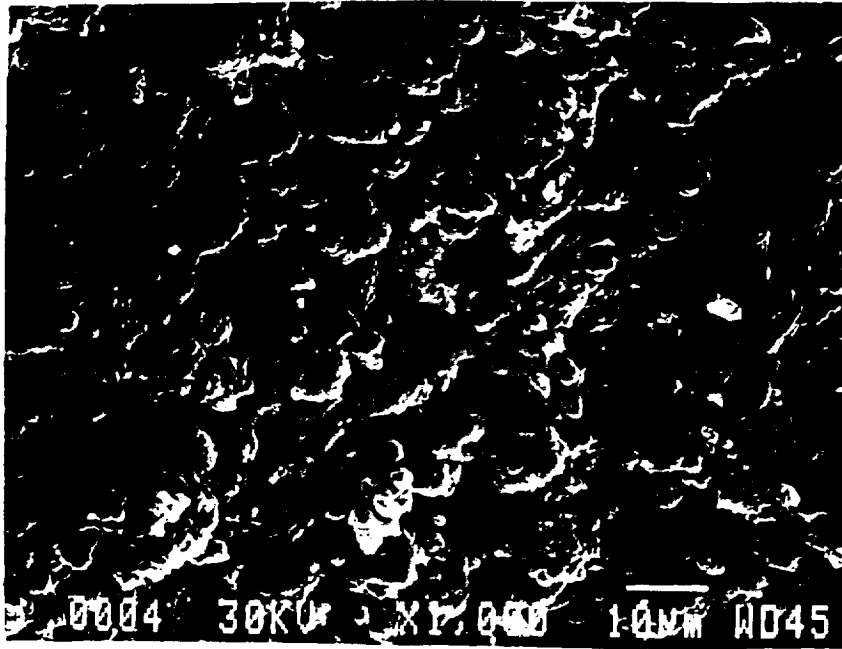

a) Precursor Powder Sieved Through 60 Mesh

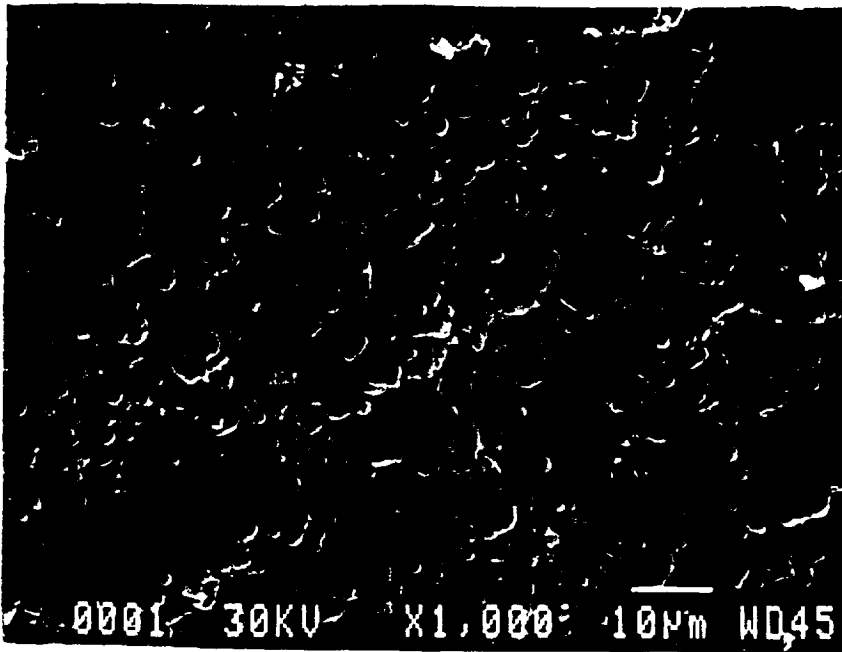

b) Precursor Powder Sieved Through 400 Mesh.

**Figure 10**

SEM Photomicrographs of the As-Fired Surface of Ceramic Tapes.

Flash-Fired at 890°C for 30 Minutes.

Nominal Composition of Precursor Powder:  $Tl_2Ba_2Ca_2Cu_3O_{10}$

1000X

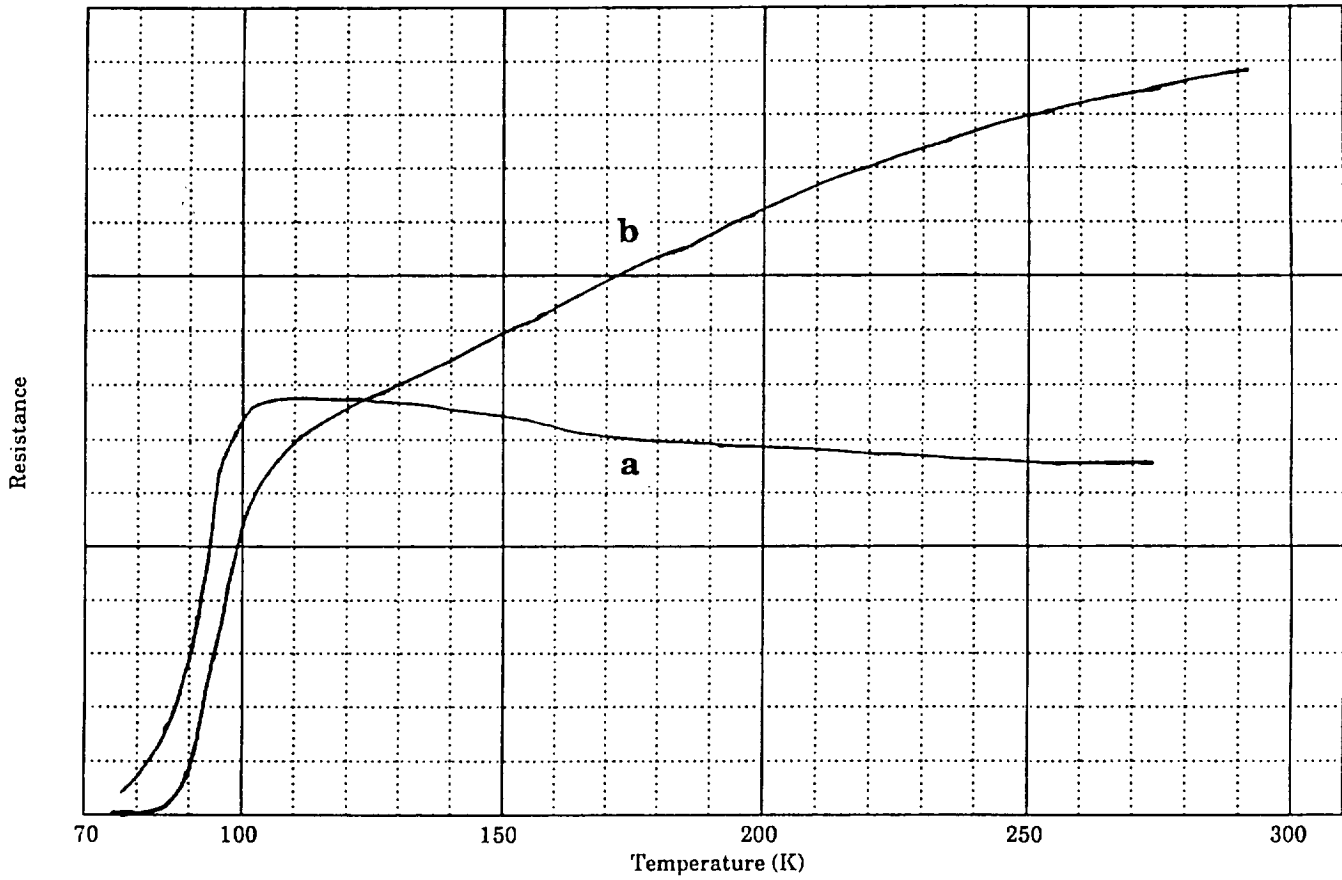

**Figure 11**

Resistance as a Function of Temperature for Ceramic Tapes.  
 Nominal Composition of Precursor Powder:  $\text{Tl}_2\text{Ba}_2\text{Ca}_2\text{Cu}_3\text{O}_{10}$   
 890°C Presinter--Sieved through 60 mesh  
 a) 30 Minute Soak at 890°C (Nonsuperconducting at 77.7K)  
 b) 60 Minute Soak at 890°C ( $T_c=90.7\text{K}$  at 100 mA)

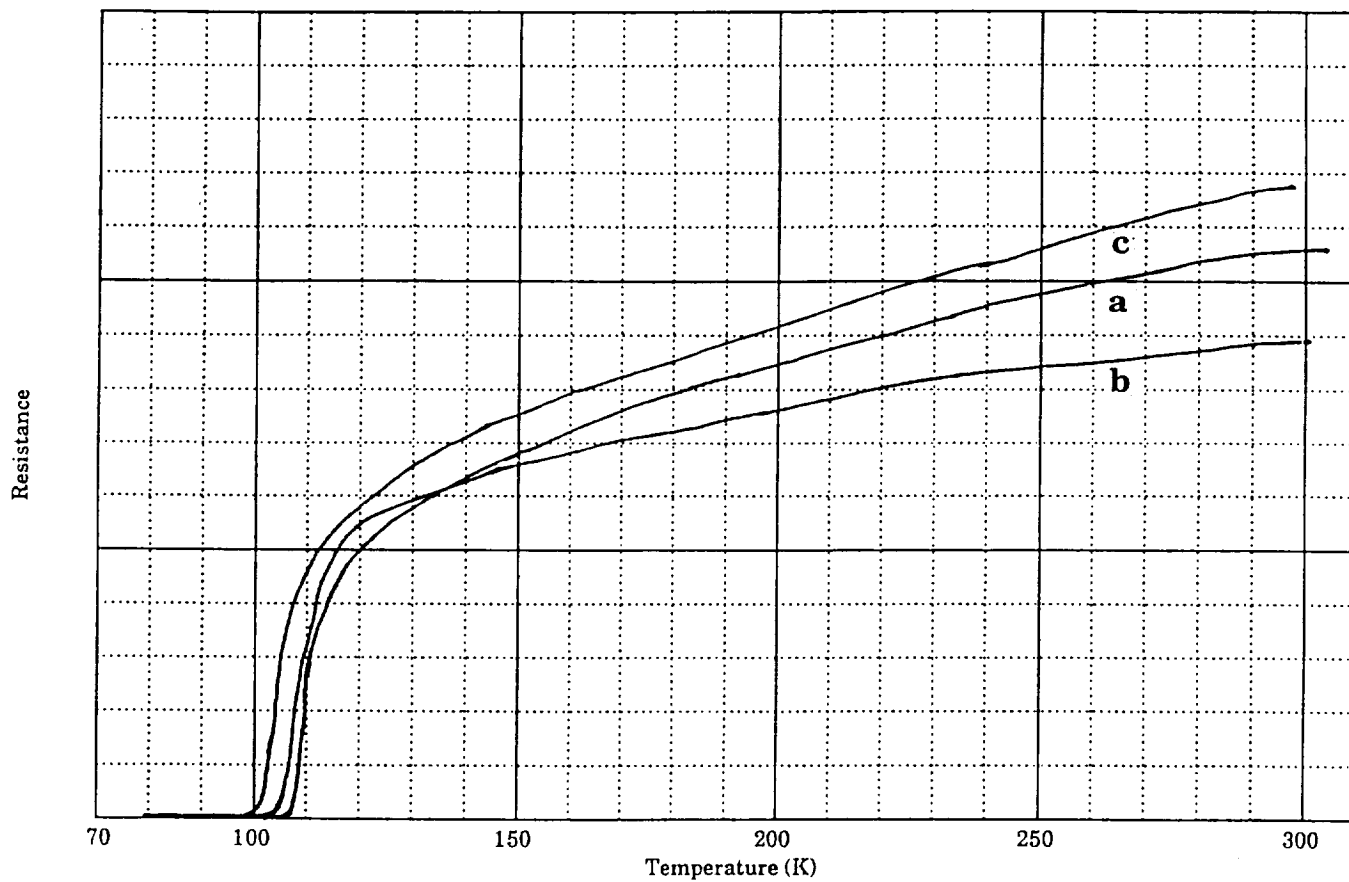

**Figure 12**

Resistance as a Function of Temperature for Ceramic Tapes.  
 Nominal Composition of Precursor Powder:  $Tl_2Ba_2Ca_2Cu_3O_{10}$   
 890°C Presinter--Sieved through 400 mesh  
 a) 30 Minute Soak at 890°C ( $T_c = 96.4K$  at 100mA)  
 b) 60 Minute Soak at 890°C ( $T_c = 104.6K$  at 100 mA)  
 c) 120 Minute Soak at 890°C ( $T_c = 106.5K$  at 100 mA)



**Figure 13**

SEM Photomicrograph of the As-Fired Surface of a Ceramic Tape.

Nominal Composition of Precursor Powder:  $\text{Tl}_2\text{Ba}_2\text{Ca}_2\text{Cu}_3\text{O}_{10}$

Presintered at  $890^\circ\text{C}$  for 360 Minutes

Passed Through 400 Mesh

Flash-Fired at  $890^\circ\text{C}$  for 120 Minutes.

**1000X**