

Third International Conference on Inverse Design Concepts and Optimization in Engineering Sciences
(ICIDES-III), Editor: G.S. Dulikravich, Washington D.C., October 23-25, 1991.

**AERODYNAMIC AIRCRAFT DESIGN METHODS
AND
THEIR NOTABLE APPLICATIONS**

— SURVEY OF THE ACTIVITY IN JAPAN —

Kozo Fujii
Institute of Space and Astronautical Science,
Yoshinodai 3-1-1, Sagami-hara, Kanagawa, 229, JAPAN

and

Susumu Takanashi
National Aerospace Laboratory
Jindaiji-Higashi 7-44-1, Chofu, Tokyo, 182, JAPAN

ABSTRACT

In the present paper, an overview of the aerodynamic aircraft-design methods and their recent applications in Japan is presented. One of the design codes which was developed at the National Aerospace Laboratory (NAL) and widely used now is mainly discussed, and hence, most of the application examples are the results of the collaborative works between heavy industries and National Aerospace Laboratory. Wide variety of applications in transonic to supersonic flow regimes are presented. Although design of aircraft elements for external flows are the main focus, some of the internal flow applications are also presented. Recent applications of the design code using the Navier-Stokes and Euler equations in the analysis mode include the design of HOPE(space vehicle) and USB(upper surface blowing) aircraft configurations.

INTRODUCTION

With the advent of supercomputers having fast processors and large memories, CFD(computational Fluid Dynamics) is progressing at incredible speed. Three-dimensional Navier-Stokes simulations, which were very rare ten years ago even for relatively simple body configurations are now common at any conference on fluid dynamics[1,2,3]. Flow field simulations over complex body configuration are not difficult task once the geometry data is given. We can learn a lot of flow physics from the simulated results that may be helpful for re-designing the body configuration. Although such simulated results give us a lot of information about the flow field, they would not tell us how to modify the body configuration for the better design. One way to do it may be a trial-and-error type approach where conducting a large number of simulations is necessary, which is still not feasible even with advanced supercomputers. So-called design programs for determining the optimum geometry may be as useful as analysis programs simulating the given flow fields.

There has been a strong effort to develop both airfoil and wing design methods for many years. Unfortunately, the progress is not as remarkable as analysis methods. This is true in Japan as well as in the United States. CFD technology has been remarkably improved last several years, but on the other hand, no much progress was made for the design methods and code development. Only one remarkable progress in Japan was the design method developed by Takanashi at National Aerospace Laboratory in 1984. His method is "iterative correction method" based on the perturbation equations of potential flows. In this method, the geometry correction is made iteratively to reduce the difference between the target pressure distributions and the

pressure distributions that is obtained by an analysis code. One of the advantages of this code is that any analysis code can be incorporated because analysis code is sort of black box for the geometry correction method. Analysis codes are not necessarily restricted to the potential codes. Even the Navier-Stokes codes can be used although the convergence is not guaranteed. Because of the flexibility and robustness of the code, it has been used for wide variety of applications. Now, most of the aircraft industries in Japan use this computer code and applied it to the practical problems.

In the present paper, Takanashi's design method and its applications are presented. Since this is a paper giving an overview of the Japanese activity, only the conceptual explanation is given about the method itself, and the focus is mainly laid on the demonstration of the applications to a wide variety of the flow fields.

DESIGN METHODOLOGY

Background

There are several approaches for the design problems. One way may be the numerical optimization using an analysis code. Wing design method was proposed by Hicks in 1976[4], and the research has been extensively conducted since then. In this optimization technique, a wing section with, for instance, minimal total drag under some constraints such as a specified lift and maximum thickness is sought by using the analysis code and the optimization code iteratively. Recently, Jameson[5] proposed an efficient method using a control theory. There exists so-called "inverse method" of wing design in which wing geometry is determined to realize the specified pressure distributions. This type of approach was used for wing design by Henne[6] and for wing-fuselage design by Shankar[7] for example. The approach used by Takanashi may be different from either of the approaches above. This is an iterative residual correction method similar to the works by Barger and Brooks[8], Davis[9], and McFadden[10] for the two-dimensional problems. The advantage of this approach is that only minimum effort in developing the geometry correction code is needed to decrease the pressure residual, while an analysis code is retained in its original form. In the next section, the formulation is briefly described.

Formulation of Inverse Problem and Iterative Procedure

Only a concept of the design method that was developed by Takanashi in 1984 is briefly described. More details can be found in his original and the following papers[11,12,13].

First, inverse problem is defined. Here the nonlinear full potential equations are taken as basic equations, and in the formulation process, small perturbations are assumed. Thus, the applicability is restricted to the flow field without shock waves or with weak shock waves. After some manipulations, integral equations that relate the geometry change and the surface pressure change are formulated. Iterative design procedure is formulated using the integral equations obtained above. Body (wing, wing-body complete aircraft etc.) surface is paneled into segments and the integral equations are discretized and numerically solved to find the necessary amount of geometry modification once the difference of required and calculated pressure difference is defined. Since we have the target pressure distributions which is required, we can define the difference using some analysis code.

The iteration process can be defined as follows. First, we assume initial body geometry, then calculate the surface pressure distributions using some analysis codes. Since we know the require pressure distributions, we can calculate the difference between the required an calculated

pressure distributions by a simple subtraction. Second, necessary body geometry change can be calculated using the integral equations which are discretized. Improved body geometry is now defined and the analysis code is once again used to calculate the pressure distribution in the second approximation. The iteration process is schematically shown in Fig. 1. One significant feature of this method is that analysis code is sort of "black box" and any type of analysis methods can be used. The Euler, Navier-Stokes, even the experimental measured data can be used to supply the pressure distribution data. They may be used so far as there occur no strong shock waves and the difference between the target and calculated pressure distributions is not large. Although there is no guarantee for the convergence in the case of some analysis code such as Euler and Navier-Stokes codes where perturbation between the geometry and surface pressure may not be uniquely defined because of the strong nonlinearity, many examples shown below indicate that the applicability of the present method is much wider than the theoretical prediction.

APPLICATION EXAMPLES

Transonic Wing Design

In Takanashi's original paper[11], applications to a couple of transonic wing design problems were presented. One of them is shown here. Figure 2 shows the original geometry data and the computed pressure distributions (dotted data). Also plotted is the target (specified) pressure distributions (solid lines). The freestream Mach number is 0.74 and the wing planform was fixed with 9.92 aspect ratio, 18.4 deg. sweep angle. The trailing-edge kink location is 30 % semispan. The target pressure distributions were determined to realize the same chordwise pressure distributions at any span station between the wing root and tip. Such pressure distributions are usually called "isobar pattern" because straight lines appear on the surface pressure contours over the entire wing surface. The chordwise pressure is determined by the two-dimensional airfoil design code, and its characteristics were investigated by airfoil analysis and wind-tunnel testings. Analysis code used in this example was "FLO22", nonlinear full potential code developed by Jameson. To avoid the monotonic increase of the thickness of the root section in the iteration process, the root section profile was fixed throughout the iteration process in this example.

Figure 3 shows the sectional wing geometry and the pressure distributions obtained after ten iterations. The target pressure distributions are almost realized. In Fig. 4, the pressure contours on the upper surface of the wing are plotted. Chordwise pressure distributions are almost the same for any spanwise station except close to the wing root section. Note that the computational time for the design mode is negligibly small compared to that of the analysis code in the iteration process.

To show that the design code can be combined with any analysis code, several computations for the design of transonic wings were carried out[12]. One of the computations using the analysis code[14] developed at the National Aerospace Laboratory is presented next. In this example, the boundary layer code also developed at the NAL[15] was incorporated. Only four iterations were necessary for the convergence. The isobar pattern is realized from the root section to the wing tip section in the computed result as is shown in Fig. 5. Mitsubishi Heavy Industries (MHI) used Takanashi's code and designed many practical wings for transonic transport aircraft[16]. As a design strategy, isobar pattern was required, and the final wing geometry was determined considering the off-design requirements about buffet, pitch-up and else. As an example, Fig. 6 shows the chordwise pressure distributions to be realized at each spanwise station. The Mach number on the design point was 0.77, and the CL was 0.65. The aspect ratio was 10, the sweep angle was 18 deg. and the tapered ratio 0.3 (see Fig. 7). The initial and the final pressure distributions along with the target pressure distributions are shown in Fig. 8, and the final wing geometry where thickness and the twisted angle are modified near the

tip to satisfy the off-design requirements is shown in Fig. 9. The wind tunnel experiment was conducted to check the aerodynamic performance of the designed wing. The measured C_p distributions are presented in Fig. 10. Reasonable agreement is observed between the target and the measured pressure distributions. Figure 11 shows the comparison of the pressure contours on the upper surface of the wing. Here again, good agreement is obtained between the computed and measured contour plots even though small discrepancy is observed near the root and tip.

At the time of this design code development, there was a collaboration between JADC representing Japanese industries and Boeing company to develop a new transonic aircraft. The project was called 7J7 in the United States, and YXX in Japan. Although this project was retorted because of the market change, there left is a lot of technology accumulations for the Research and Development. Under this project, many wing configurations were designed by Mitsubishi Heavy Industries again using Takanashi's code. Some of the designed wings were used for the simulations using the Reynolds-averaged Navier-Stokes equations[17,18] and the computed results were compared with the corresponding experiments[19] to confirm the aerodynamic performance of the designed wings. These examples will be shown at the conference.

Airfoil Design Using Navier-Stokes Equations

As has been mentioned above, the analysis code is sort of a "black box" and it can use any analytical method even though the convergence is not necessarily guaranteed. Hirose et al. coupled Takanashi's design code with two-dimensional Reynolds-averaged Navier-Stokes code[20]. With specifying the same pressure distributions at each spanwise station for large aspect ratio wing, the three-dimensional design code was incorporated with the two-dimensional Navier-Stokes code for the design of two-dimensional airfoil. One of the application examples is shown here. Shockless supercritical pressure distributions at $Cl= 0.6$ was specified as a target and the initial geometry was set up to have strong shock wave. The freestream Mach number is 0.75 at the Reynolds number 13 million. The initial, target and computed C_p distributions along with the initial and final airfoil geometries are plotted in Fig. 12. The target C_p distributions are almost realized in ten iterations.

Two Dimensional Transonic Cascades

Takanashi reformulated his original design code and developed a two dimensional cascade design program in 1986. The analysis code in this case is a Euler code using explicit time integration. Even after 10 iterations, fully converged solution was not obtained. However, the pressure is becoming closer and closer to the target pressure on every iteration stages. The solution after 10 iterations is presented in Fig. 13 along with the cascade geometry. Takanashi insisted in his paper[13] that the convergence would be much improved by optimizing the parameters in the design process for cascade flows.

Additional Applications

Recently, with the rapid progress of supercomputers, the design code above was combined with three-dimensional Navier-Stokes codes and applied to more difficult cases. Both Mitsubishi (MHI) and Kawasaki (KHI) Heavy Industries applied it to the design of HOPE(H-II Rocket Orbiting Plane). The HOPE is a space vehicle that NASDA (National Space Development Agency) is currently developing. Both companies were interested in redesigning the tip fin of the configuration. MHI analysed the transonic flow at Mach number 0.9 with 5 degrees angles of attack and the Reynolds number 2 million[21]. They found by the Navier-Stokes simulations that the flow field surrounded by the fuselage, main wing and tip fin became almost channel flow and strong shock wave and associated flow separation occurred. The Takanashi's design code was

iteratively used with the three-dimensional Navier-Stokes code and the good improvement was obtained after five iterations. They used half a million of grid points for the Navier-Stokes analysis and the computer time required for each iteration step was 5 hours for the analysis mode and 0.2 hours for the design mode. Thus, in total, 26 hours were necessary even with the Fujitsu VP400, one of the most advanced supercomputers at that time. The initial body configuration is shown in Fig. 14 in terms of the computational grid. The initial and the final chordwise pressure distributions on the tip fin are presented in Fig. 15 with the corresponding sectional geometries. Although the target pressure is not precisely realized, there is obvious improvement such as disappearance of the suction peak. The close-up views of the near-surface streamlines obtained from the computed flow fields both for the initial and obtained configurations are presented in Fig. 16. Shock wave is weakened and the flow separation on the tip fin surface disappears in the final configuration.

Kawasaki Heavy Industries tried to modify the pressure distributions over the tip fin to satisfy the buffet boundary by re-designing the tip fin using Takanashi's design code with the Euler code[22]. About 200,000 grid points were used in the analysis mode and total computer time for five iterations was about 5 hours. In this example, the freestream Mach number is 0.9 and the angle of attack is 6.5 degrees. The original and designed sectional geometries, and the initial and final C_p distributions along with the target C_p are presented in Fig. 17. Remarkable improvement is observed although the target C_p distributions are not realized also in this example.

Kawasaki Heavy Industries also applied the design code for the redesign of the USB (Upper Surface Blowing) wing configuration of the STOL[23]. The planform of the USB is shown in Fig. 18. In this example, isobar pattern is the target, but the wing section is fixed near the nacelle and the tip to avoid resulted very thin wing section to weaken the shock wave. Figure 19 shows the sectional C_p distributions. The strong shock wave that appeared on the initial configuration is weakened and the target C_p distributions are almost realized.

Another aircraft company named Fuji Heavy Industries developed their own design code based on the Takanashi's method. They applied it to the design problem of wing-fuselage combination[24]. The analysis code was full potential code. The target pressure distributions were such that realize the isobar pattern on the wing surface and are the same as the initial ones on the fuselage. The initial and final C_p distributions and the surface pressure contours are plotted in Fig. 20. The computed C_p in the lower surface realizes the target C_p , but still some discrepancy exists on the upper surface. However, compared to the initial C_p distributions, improvement is obvious. The final configuration is shown in Fig. 21.

SUMMARY

An overview of the Aerodynamic aircraft-design methods and their recent applications in Japan was presented. One of the design codes developed at the National Aerospace Laboratory (NAL) is mainly discussed because of its popularity in Japan, and wide variety of applications were presented from transonic to supersonic flow regimes. This design method uses inverse design code and analysis code iteratively to realize the required pressure distributions, and thus any analysis code can be used. Some of the examples shown here used Euler and Navier-Stokes code as an analysis mode. These application examples indicated the capability and feasibility of the design code. The fact that many companies currently use this design code for practical problems and obtain successful results proves it.

This paper is written based on the results that the first author has noticed. There may be more activities in Japan that can not be included in the paper. Unfortunately many of the papers in the reference list are written in Japanese. However, some of the important papers such as

Takanashi's original paper are written in English and the authors hope that the list of reference in this paper is useful for any researchers for the design problems.

ACKNOWLEDGEMENT

The first author of this paper only surveyed the development of the design methods in Japan, and did not contribute to the research at all. Many of the results shown in this paper are the contribution of many researchers in Japan. The authors would like to thank all of them that supplied computed results for this survey paper. Three aircraft companies, Fuji Heavy Industries, Kawasaki Heavy Industries and Mitsubishi Heavy Industries are greatly acknowledged for helping the authors to write this paper.

REFERENCES

1. Buning, P. G. et al., "Numerical Simulation of the Integrated Space Shuttle Vehicle in Ascent," AIAA Paper 88-4359, 1988.
2. Rizk, Y. M., Schiff, L. B., and Gee, K., "Numerical Simulation of the Viscous Flow Around Simplified F/A-18 at High Angle of Attack," AIAA Paper 90-2999, 1990.
3. Yeh, D. et al., "Numerical Study of the X-31 High Angle of Attack Characteristics," AIAA Paper 91-1630, 1991.
4. Hicks, R. M. et al., "Airfoil Section Drag Reduction at Transonic Speeds by Numerical Optimization," SAE Paper 760477, 1976.
5. Jameson, A., "Aerodynamic Design Via Control Theory," ICASE Report No. 88-64, 1988.
6. Henne, P. A., "Inverse Transonic Wing Design Method," J. Aircraft, Vol. 18, No.2, pp. 121-127, 1981.
7. Shankar, V., "A Full Potential Inverse Method Based on a Density Linearization Scheme for Wing Design," AIAA Paper 81-1234, 1981.
8. Barger, R. L. and Brooks, C. W., "A Streamwise Curvature Method for Design of Supercritical and Subcritical Airfoils," NASA TN D-7770, 1974.
9. Davis, W. H. Jr., "Technique for Developing Design Tools from the Analysis Methods of Computational Aerodynamics," AIAA Paper 79-1529, 1979.
10. McFadden, G. B., "An Artificial Viscosity Method for the Design of Supercritical Airfoils," Ph D. Thesis, New York Univ., 1979.
11. Takanashi, S., "Iterative Three-Dimensional Transonic Wing Design Using Integral Equations," J. Aircraft, Vol. 22, No. 8, pp. 655-660, 1985.
12. Takanashi, S., "Transonic Wing and Airfoil Design Using Inverse Code WINDES," Proc. 3rd NAL Symposium on Aircraft Computational Aerodynamics, NAL SP-5, 1985 (in Japanese).
13. Takanashi, S. et al., "Inverse Design Method for Two-Dimensional Transonic Cascades," Proc. 4th NAL Symposium on Aircraft Computational Aerodynamics, NAL SP-7, 1986 (in Japanese).

14. Ishiguro, T. et al., "Numerical Analysis of Inviscid Flows about Wing-Fuselage Combinations, III Calculation Based on the Euler Equations," NAL TR-896, 1985 (in Japanese).
15. Matsuno, K., "A Vector-Oriented Finite-Difference Scheme for Calculating Three-Dimensional Compressible Laminar and Turbulent Boundary Layers on Practical Configurations," AIAA Paper 81-1020, 1981.
16. Tanioka, T et al., "Wing Design Using Three-Dimensional Transonic Inverse Method," Proc. 22th Aircraft Symposium, 1984 (in Japanese).
17. Fujii, K. and Obayashi, S., "Navier-Stokes Simulations of Transonic Flows Over a Practical Wing Configuration," AIAA Journal, Vol. 25, No. 3, pp. 369-370, 1987.
18. Fujii, K. and Obayashi, S., "Navier-Stokes Simulations of Transonic Flows Over a Wing-Fuselage Combination," AIAA Journal, Vol. 25, No. 12, pp. 1587-1596, 1987.
19. Miyakawa, J, et al., "Searching the Horizon of Navier-Stokes Simulation of Transonic Aircraft," AIAA Paper 87-0524, 1987.
20. Hirose, N., et al., "Transonic Airfoil Design Based on Navier-Stokes Equation to Attain Arbitrary Specified Pressure Distribution -an Iterative Procedure, " AIAA Paper 85-1592, 1985.
21. Kaiden, T. et al., "Aerodynamic Design of Non-Planar Wing by Inverse Method with Navier-Stokes Equation," Proc. 8th NAL Symposium on Aircraft Computational Aerodynamics, " NAL SP-14, 1990 (in Japanese).
22. Sakai, K., "Wind Tunnel Experiments and Computational Fluid Dynamics at KHI," Proc. 9th NAL Symposium on Aircraft Computational Aerodynamics, " to be published as NAL SP, 1991(in Japanese).
23. Takahashi, H. et al., "Wing Design of Small Transport Aircraft Using Three-Dimensional Inverse Method," Proc. 27th Aircraft Symposium, 1989 (in Japanese).
24. Tani, Y. et al., "Blended Wing-Body Configuration Design Using Transonic Inverse Code, " NAL SP-14, 1990 (in Japanese).

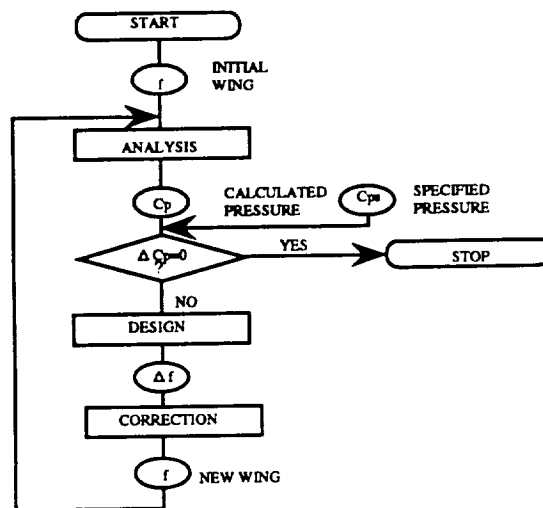

Fig. 1 Iterative design process.

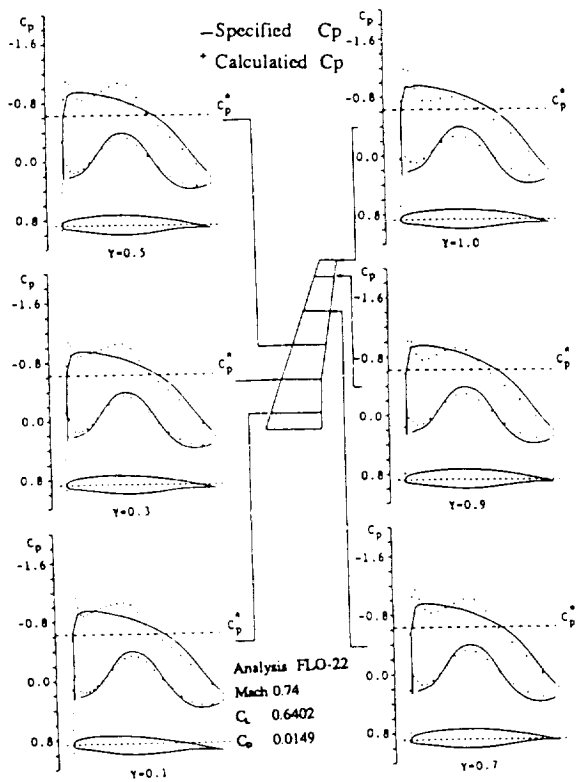

Fig. 2 Initial wing geometry with the plots of corresponding computed pressure distributions and the specified(target) pressure distributions[11].

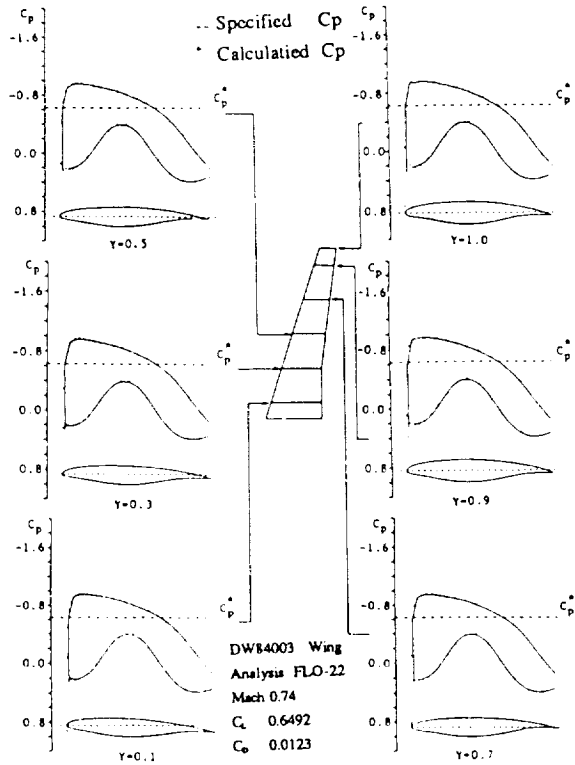

Fig. 3 Designed wing geometry and the pressure distributions[11].

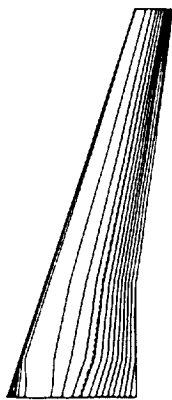

Fig. 4 Pressure contour plots on the upper surface of the designed wing[11].

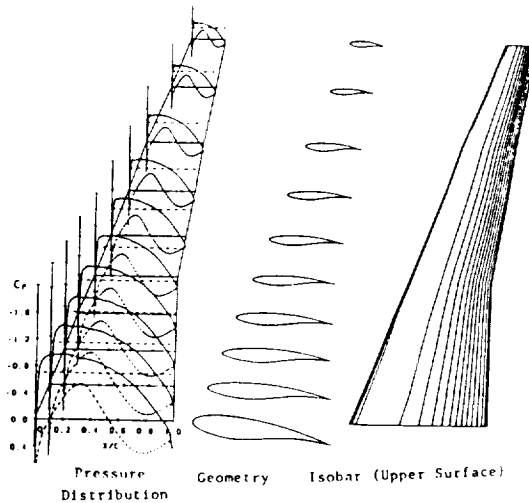

Fig. 5 Designed wing geometry with the plots of the pressure distributions and the upper surface pressure contour plots (potential code and the boundary code were used in the analysis mode)[12].

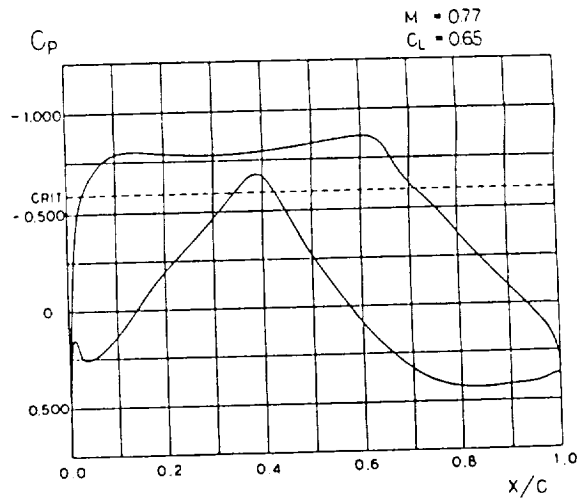

Fig. 6 Target chordwise pressure distributions at each span station[16].

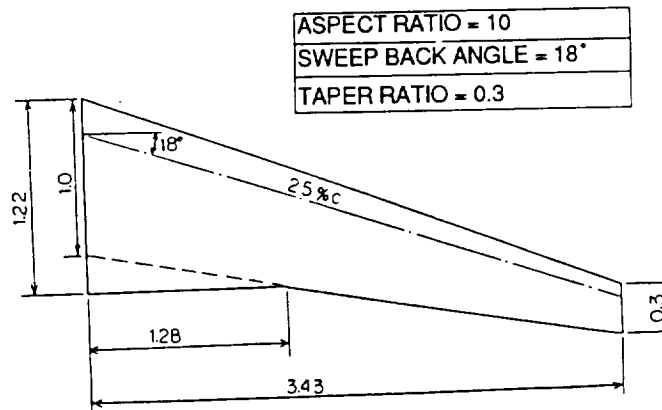

Fig. 7 Wing planform (fixed)[16].

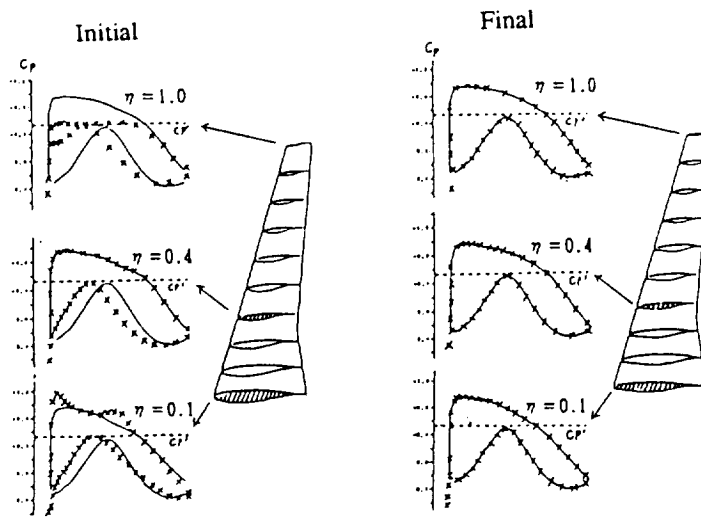

Fig. 8 Initial and final pressure distributions along with the target pressure distributions plotted with the wing geometries[16].

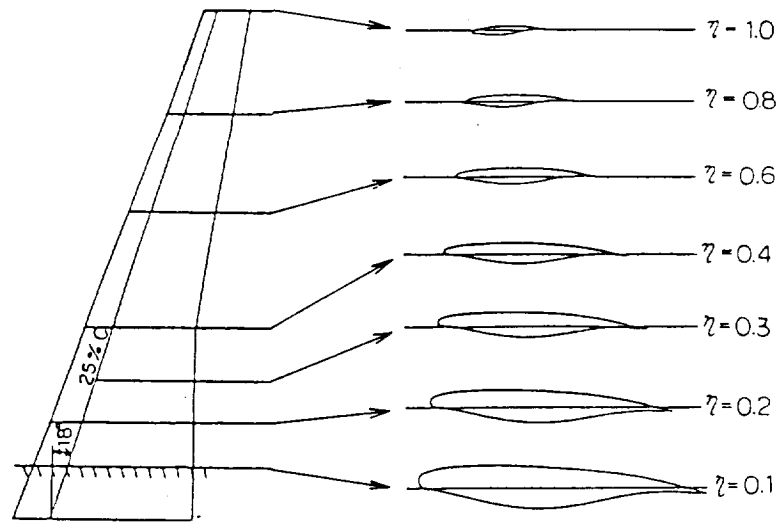

Fig. 9 Final wing geometry taking off-design requirements into account[16].

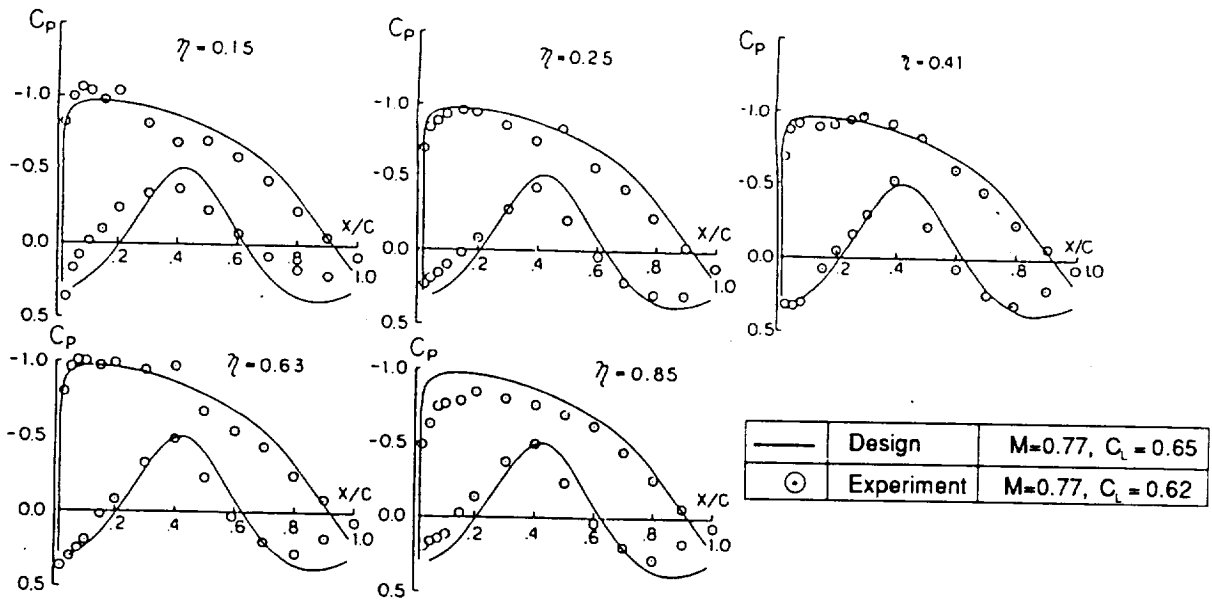

Fig. 10 Experimentally measured and designed pressure distributions[16].

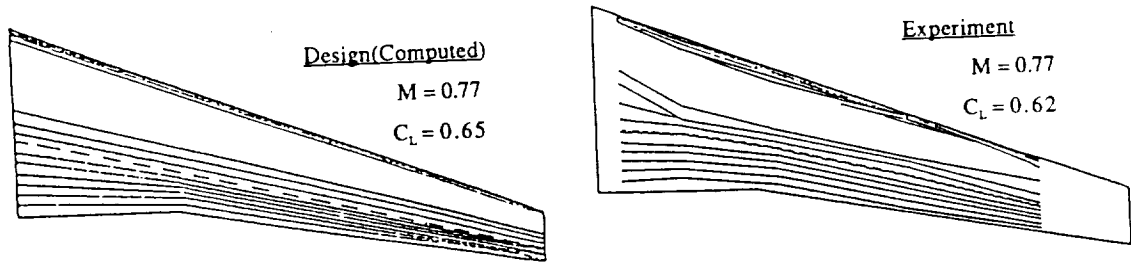

Fig. 11 Computed and experimentally measured pressure contour plots on the upper surface of the wing[16].

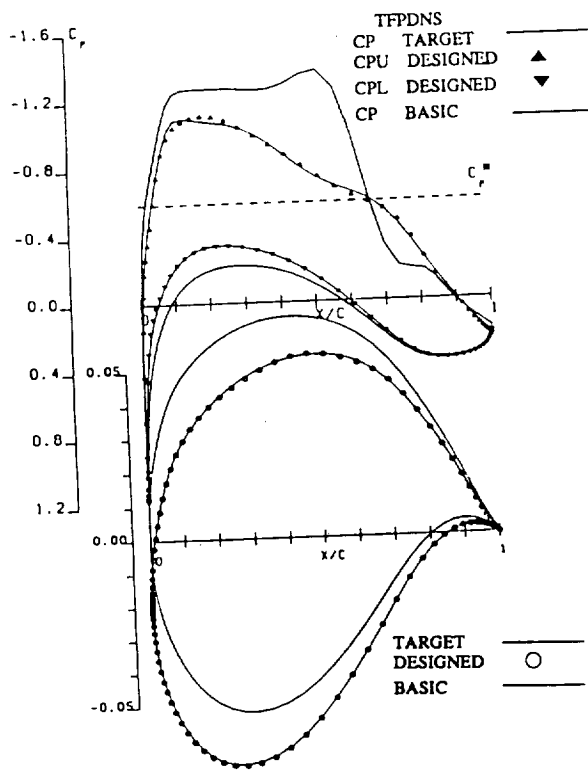

Fig. 12 Comparison of the initial, target and designed Cp distributions along with the initial and final airfoil geometries[20].

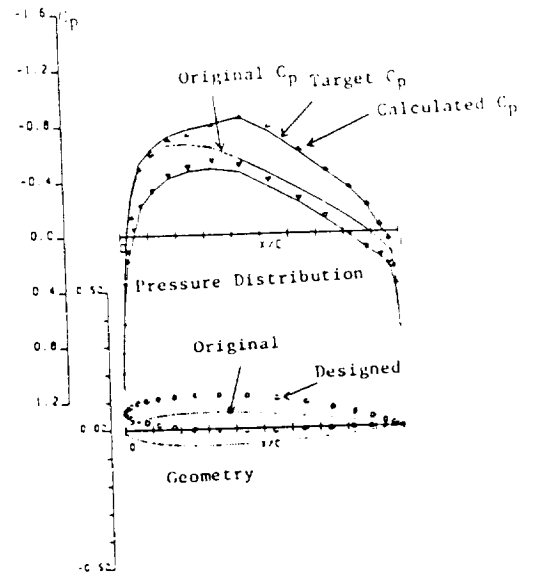

Fig. 13 Initial, target and designed Cp distributions with the initial and final cascade geometries[13].

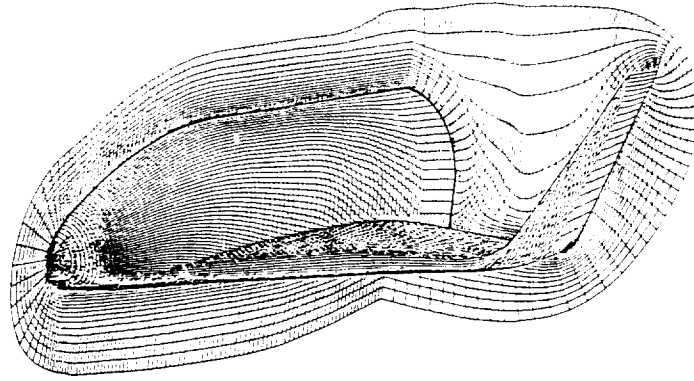

Fig. 14. Computational grid over a HOPE configuration[21].

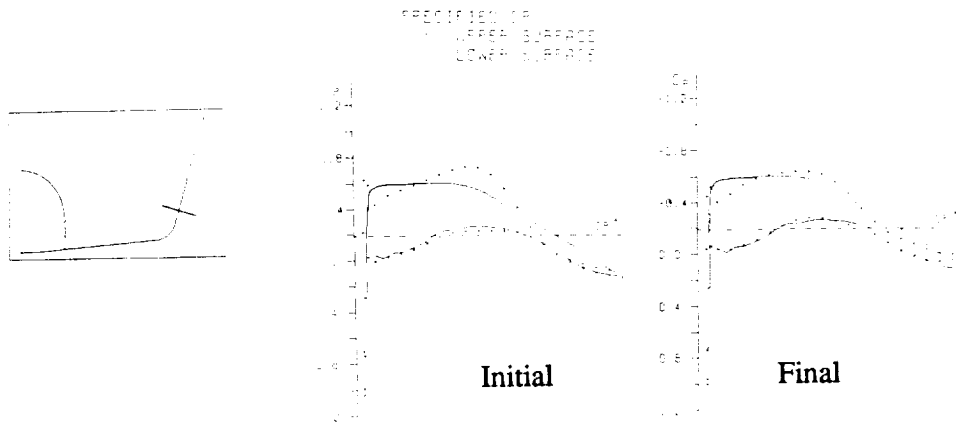

Fig. 15 Initial and final chordwise pressure distributions over the tip fin of the HOPE and their spanwise sections[21].

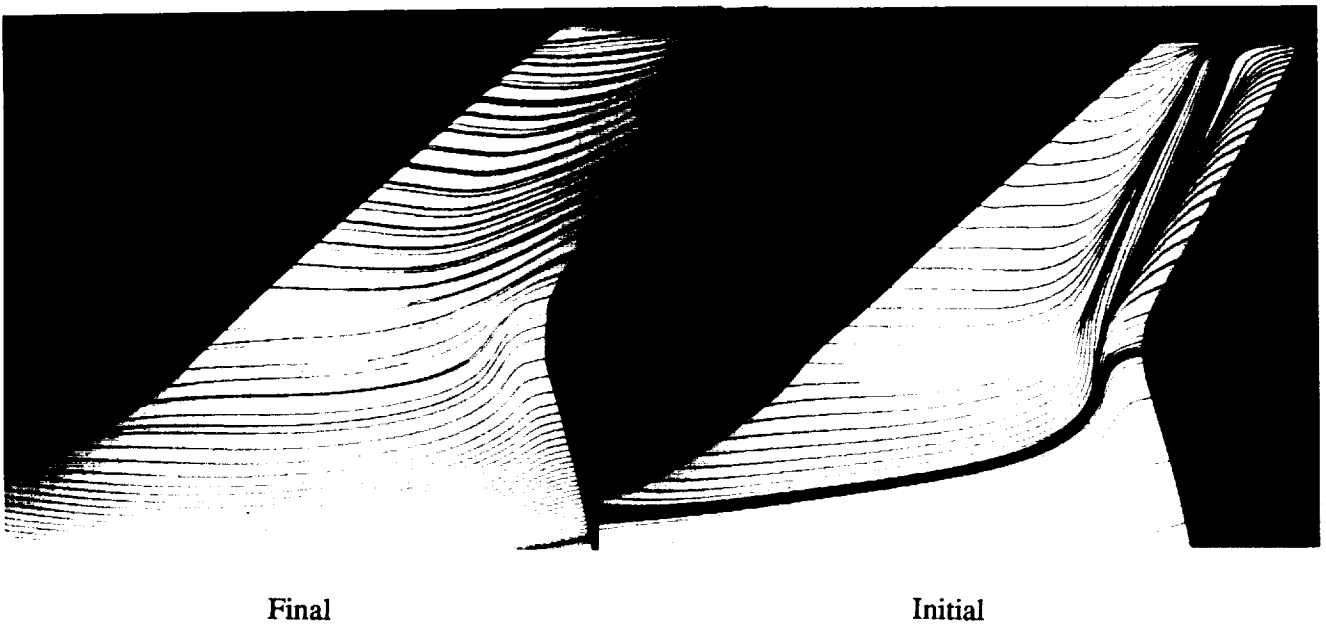

Fig. 16 Computed near-surface streamlines for the initial and final HOPE configurations[20].

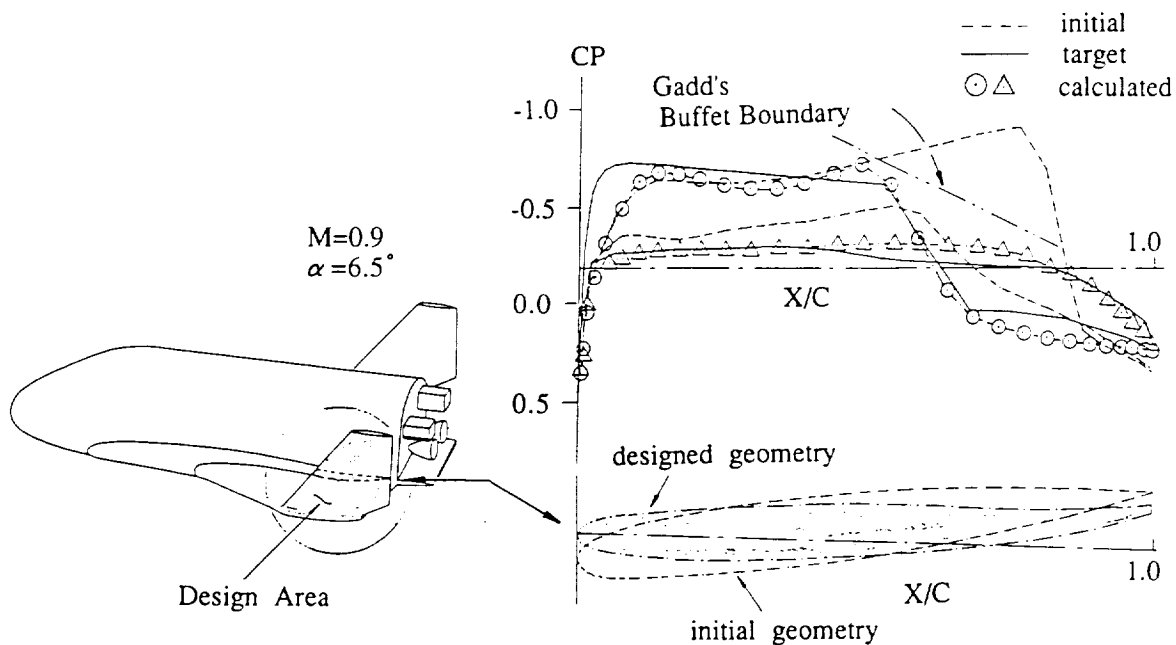

Fig. 17 Wing tip design of HOPE by KHI; initial and final chordwise pressure distributions over the tip fin and their spanwise sections[22].

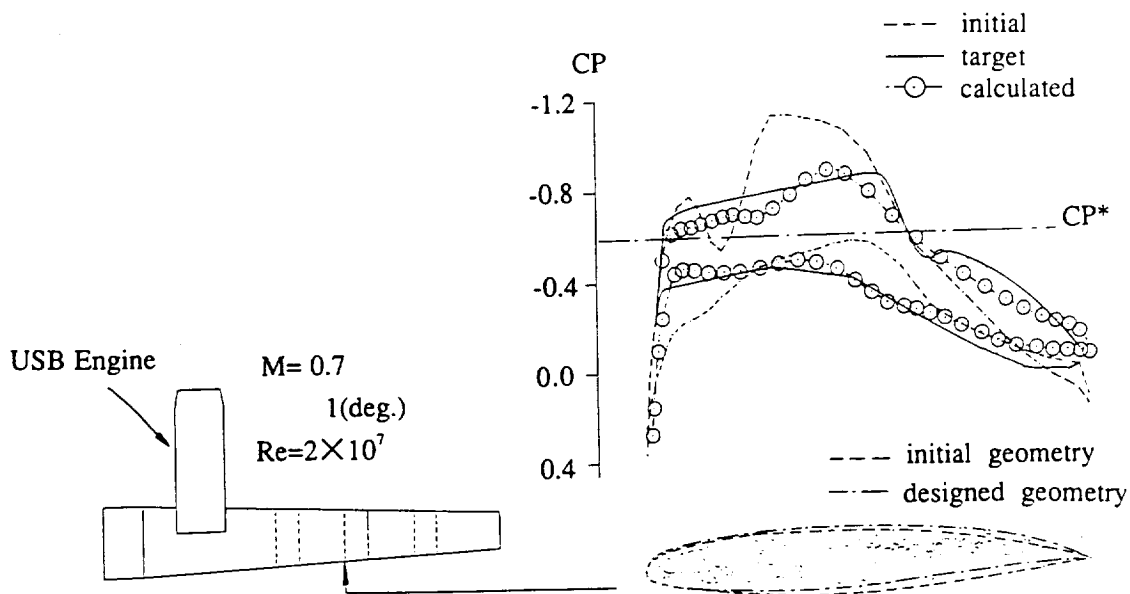

Fig. 18 USB wing planform[23].

Fig. 19 Sectional Cp distributions; initial and final Cp's and their geometries[23].

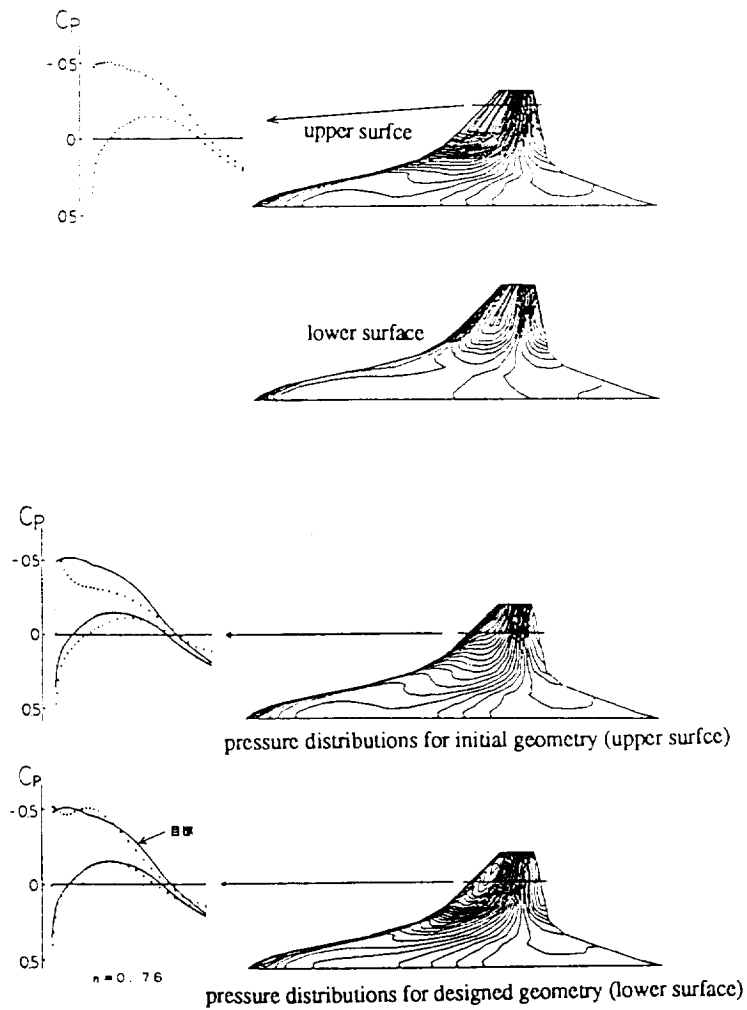

Fig. 20 Wing-body combination design by FHI; initial and final chordwise C_p distributions and surface pressure contour plots[24].

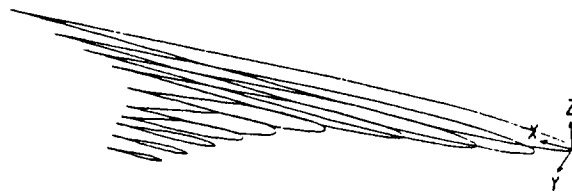

Fig. 21 Final designed wing-body combination[24].