

1N-05  
77636  
p. 20

NASA Technical Memorandum 103875

---

# Tiltrotor Research Aircraft Composite Blade Repairs— Lessons Learned

---

Paul S. Espinosa and David R. Groepler

---

(NASA-TM-103875) TILTROTOR RESEARCH  
AIRCRAFT COMPOSITE BLADE REPAIRS: LESSONS  
LEARNED (NASA) 20 p C5CL 01C

N92-19563

Unclas  
G3/05 0077036

December 1991

**Presentation Paper**—This report was presented at the Eighth International Conference on Composite Materials, Honolulu, July 1991.



---

# Tiltrotor Research Aircraft Composite Blade Repairs— Lessons Learned

---

Paul S. Espinosa and David R. Groepler, Ames Research Center, Moffett Field, California

December 1991



National Aeronautics and  
Space Administration

**Ames Research Center**  
Moffett Field, California 94035-1000

## Summary

The XV-15, N703NA Tiltrotor Research Aircraft located at the NASA Ames Research Center, Moffett Field, California, currently uses a set of composite rotor blades of complex shape known as the advanced technology blades (ATBs). The main structural element of the blades is a D-spar constructed of unidirectional, angled fiberglass/graphite, with the aft fairing portion of the blades constructed of a fiberglass cross-ply skin bonded to a Nomex honeycomb core. The blade tip is a removable laminate shell that fits over the outboard section of the spar structure, which contains a cavity to retain balance weights. Two types of tip shells are used for research. One is highly twisted (more than a conventional helicopter blade) and has a hollow core constructed of a thin Nomex-honeycomb-and-fiberglass-skin sandwich; the other is untwisted with a solid Nomex honeycomb core and a fiberglass cross-ply skin. During initial flight testing of the blades, a number of problems in the composite structure were encountered. These problems included debonding between the fiberglass skin and the honeycomb core, failure of the honeycomb core, failures in fiberglass splices, cracks in fiberglass blocks, misalignment of mated composite parts, and failures of retention of metal fasteners. Substantial time was spent in identifying and repairing these problems. This paper discusses the types of problems encountered, the inspection procedures used to identify each problem, the repairs performed on the damaged or flawed areas, the level of criticality of the problems, and the monitoring of repaired areas. It is hoped that this discussion will help designers, analysts, and experimenters in the future as the use of composites becomes more prevalent.

## 1. Introduction

### 1.1 Background

The XV-15, N703NA (fig. 1) is one of two aircraft designed and manufactured by Bell Helicopter Textron Inc. (BHTI) in the 1970's to demonstrate tiltrotor proof-of-concept technology under a NASA-Army contract. The XV-15 aircraft designated N703NA was accepted by NASA in 1980 for testing at the Ames Research Center, Moffett Field, California. The other aircraft is currently being tested by Bell Helicopter at the Arlington, Texas, Flight Test Center.

The tiltrotor aircraft is unique in its ability to fly as a helicopter, with vertical-take-off, hover, and landing capability, and also as a conventional fixed-wing aircraft with the benefit of the latter's greater cruise speed and efficiency. The XV-15 has two 25-ft (7.62-m) rotors and nacelles that

house the engines and transmissions at the tips of a forward-swept wing. The aircraft has an "H" tail design and tricycle retractable landing gear. The tilting nacelles are pointed upward for flight in helicopter mode and rotated forward for flight in airplane mode. The XV-15 flight modes are illustrated in figure 2. The rotors are interconnected by a drive shaft that passes through the wing so that both rotors continue to rotate in the event of an engine failure. The pilot's flight controls resemble those of a conventional helicopter, and combine the functions of a helicopter and a conventional aircraft into a single set of controls for the pilot and a duplicate set for the copilot.

The XV-15 initially used a set of metal blades. After successful completion of the initial testing program, an investigation of the application of advanced aerodynamics and structural materials to the tiltrotor aircraft's rotor blades was initiated. An airworthy set of rotor blades called advanced technology blades (ATBs) was developed by the Boeing Vertol Company to be used on the NASA Ames XV-15. These blades were designed to be capable of operating at the aircraft's design transmission torque rating, which is about 25 percent above the transmission operating limits of the original metal blades.

The nonuniform variation of geometry along the span of the ATB is a good example of the versatility of composite materials in obtaining optimum aerodynamic shapes. The ATBs (fig. 3) have 43 deg of nonlinear twist, a nonuniform tapered planform, and thin airfoils, required for tiltrotor aerodynamic efficiency. Thus the objectives of the ATB investigation were to address aerodynamic, structural, material, and manufacturing issues. The specific objectives were to

- (1) improve the "productivity index" of the XV-15 (measured by the product of payload and cruise speed divided by the empty weight) by increasing payload capability without degrading cruise speed;
- (2) improve blade fatigue strength and extend the service life and transition flight envelope in areas where it is limited by the strength of the metal blades;
- (3) demonstrate the feasibility of manufacturing processes for highly twisted composite tiltrotor blades of unconventional design;
- (4) demonstrate structural properties, improve rotor performance, and reduce blade loads by ground and flight-test evaluation (ref. 1).

A set of three ATBs was first tested in 1984 at the Ames Outdoor Aerodynamic Research Facility (OARF) on the prop test rig. After more than 26 hr of testing, the blades were returned to Boeing for refurbishment and inspection,

after which a total of 8 blades (one complete ship set and one spare blade per side) were shipped by Boeing to Ames. In 1987, the ATBs were installed on the XV-15. The blades were operated on the aircraft on a ground tie-down test stand (fig. 4) before actual flight. The first free flight of the blades was in 1988. They have now accumulated approximately 45 hr of operational time.

## 1.2 Description

The major components of the XV-15 ATBs (fig. 5) are the main structural assembly of the blade, a blade-spar-extension tip-weight-fitting assembly, a removable tip cover, a removable cuff fairing (not shown), and a 4340 steel pitch housing with attachment pins. A description of the design and a discussion of material selection are provided in reference 2.

**1.2.1 Main structural assembly**– A typical cross section of the main structural assembly of the ATB is shown in figure 6. The D-spar is constructed of unidirectional and angled fiberglass/carbon. The spar is coated with a thin layer of aluminized fiberglass cloth for lightning protection. A cap covers the leading edge of the spar to provide erosion protection. A polyurethane erosion cap is used inboard of the 68% radius, and an electroformed nickel nose cap is employed from the 68% radius to the blade tip to provide protection at the high local-impact speeds. The aft fairing section of the blade is constructed of a  $\pm 45$ -deg-biasply fiberglass epoxy skin bonded to a Nomex honeycomb core.

**1.2.2 Blade-spar-extension tip-weight-fitting assembly**– A unidirectional fiberglass epoxy nose block at the end of the spar allows for the addition and removal of track and balance weights. The weight housing is constructed from molded blocks bonded together with EA9628 and EA9309.2 adhesive. Unidirectional fiberglass wraps extend from the main spar around the tip weight fitting to provide centrifugal force retention. The cavities in each blade can hold up to 3.5 lb (1.59 kg) of balance weights and 1.4 lb (0.635 kg) of track adjustment weights.

**1.2.3 Tip cover**– The blades have a removable tip cover which provides access to the track and balance weights located in the tip-weight-fitting assembly at the end of the D-spar. The removable tip can be switched with other tips to allow for variations in tip geometry (for aerodynamic configuration changes). Currently there are two airworthy types of blade tips available for flight testing. The first type flown on the ATBs, called the baseline tip cover, has a high aerodynamic twist and a hollow aft fairing area. A cross section through this design is shown in figure 7. The leading edge of the tip is a solid fiberglass skin, and the

trailing edge is constructed of a thin Nomex honeycomb sandwich core 0.100 in. (0.254 cm) thick with a preimpregnated glass-weave skin 0.018 in. (0.046 cm) thick on the outer and inner surfaces, with a  $\pm 45$ -deg orientation. There is a cavity extending through the entire tip with a shear splice made of a thin fiberglass web between the upper and lower surfaces of the tip to provide rigidity while the tip is installed or removed from the blade.

Another tip cover with the same airfoil and planform but with no twist (called the “alternate tip”) replaced the baseline tip later in the testing program. This design has a solid honeycomb core throughout except for a small cavity that fits over the spar-extension weight block when the tip is placed on the blade. Both tips are retained by screws that attach to inserts located in the blade main spar and spar extension. A view of the tip assembly showing the retaining screw locations is presented in figure 8.

**1.2.4 Root end cuff**– The aerodynamic fairing at the root of the blade is removable to provide access to the blade retention pins and clevis and to provide access to instrumentation wiring. The removability of this “cuff” section also allows changes to be made in the cuff geometry for research purposes. The cuff structure is a bias-ply Nomex honeycomb sandwich shell. No major problems were encountered with the cuff so it is not discussed in this paper.

## 2. ATB Blade Repairs

The primary structure of the ATBs has performed very well. However, a number of problems were encountered with the secondary structure of the blades during the initial flight-testing phase. None of the structural problems posed a flight-control or loads problem during flight, and all of the structural problems were found during inspections performed between flights. Several components of the blades were identified as recurring problem areas, and much time was spent working on them. Typically, the first occurrence of a specific problem consumed much time and effort for evaluation and repair. Further problems of the same type required less time for resolution. This section will cover the most common problems encountered, grouped as follows:

- (1) Debonding between the fiberglass skin and the honeycomb core
- (2) Failure of the honeycomb core
- (3) Failures in fiberglass splices
- (4) Cracks in fiberglass blocks

- (5) Misalignment of mated composite parts
- (6) Failures of retention of metal fasteners

For each type of problem described, the following are discussed:

- (1) Description of the problem—flight hours when a problem was found, cause of the problem, other associated failures, and disposition
- (2) Inspection procedures—when to perform an inspection, the type of inspection performed, methods for inspecting problem areas, problems with the inspection technique, and alternate inspection methods
- (3) Repairs performed—corrective actions, modifications, and repair procedures
- (4) Level of severity and monitoring of critical problems—determination of problem criticality, and monitoring of problem areas

## **2.1 Debonding Between the Fiberglass Skin and the Honeycomb Core**

**2.1.1 Description of the problem**— After 24.1 hr of operation, two baseline blade-tip covers showed separation of the fiberglass skin from the honeycomb core. After 25.8 hr another tip was found to have been debonded. The surface area of the debonds varied from 4 to 10 in.<sup>2</sup> (25.8 to 64.5 cm<sup>2</sup>). Debonding of the tips in these cases was determined to have been caused by failure of the adhesive between the skin and the honeycomb structure. Subsequent operations with the sturdier alternate tip (solid honeycomb throughout) have been free of further debond problems. No debonds have been found in the main structural assembly of the blade.

**2.1.2 Inspection procedures**— A visual inspection of the surface of the blades and tips was performed after each flight, and if a suspect area was indicated by a rise or dimple in the skin, then a detailed tap test was performed to determine the location of the debonding of the fiberglass skin from the honeycomb core. Tap testing was performed using either a coin (e.g., a quarter) or a small tapping hammer. By tapping lightly in the area of the debond, differences in the sound emitted from the tapping was used to verify and map out debonded areas.

Even though experienced personnel performed the tap-test inspection, on many occasions it was not completely clear that a debond existed or where its boundaries were. Also, any variation in the tip structural cross section (e.g., a spar, extra layers of fiberglass skin, or a thick deposit of adhesive) would provide a tapping sound which could be difficult to interpret or could be falsely interpreted as a debond. Differentiating these sounds from the sound of a

true debond, and clearly identifying the boundaries of the debond, was subject to the interpretation of the person performing the tap test.

The problem of relying on subjective interpretations of tap-testing sounds is expected to be alleviated by the use of an electronic tapper acquired after all the problems described in this paper were resolved. The device selected is a Mitsui Woodpecker WP-632 Tapping Exfoliation Detector and monitoring unit (ref 3). It provides a digital readout based on reflected energy from an electronically controlled mechanical tapper. This sensitive device is used to differentiate between debonds and nonuniformities under the skin. Judging from tests performed on a sample honeycomb sandwich panel consisting of known voids and debonds, the electronic tapper is able to differentiate between voids, debonds, and cells filled with adhesive, and can clearly map their boundaries.

**2.1.3 Repairs performed**— After the tip was removed from the blade, debonds were repaired by injection of adhesive into the debonded area. The skin surface of the debonded area was first sanded with a fine-grit sandpaper to remove paint and primer. Small holes were drilled in the skin in the center of selected honeycomb cells in the debonded area. Into each hole a small amount of Hysol 956 adhesive was injected. The blade tip was rotated so that the adhesive coated the debonded interface between the skin and the core. After the 956 adhesive cured, the holes in the fiberglass skin were filled with Hysol EA9309.1 adhesive, which was allowed to cure, and then the area was sanded to the surface contour and refinished.

**2.1.4 Level of severity and monitoring of critical problems**— Debonds were considered to be a critical problem for the baseline tip's thin honeycomb sandwich since they affect the structural integrity of the tip cover. A conservative engineering analysis was performed and it was determined that a void or debond up to 2.5 in. (6.35 cm) in diameter in the aft fairing of the tip structure could be supported by the tip during flight and would not lead to immediate failure of adjacent structures. Therefore, a void or debond less than 2.5 in. (6.35 cm) in diameter was marked and monitored and all voids or debonds over this size were repaired. However, a void or debond of less than 2.5-in. (6.35 cm) diameter in which the skin was cracked, which could increase in size during the next flight, was repaired immediately.

The boundaries of the areas determined to be flawed, or suspect areas (these areas sounded irregular, but further inspection could not confirm the existence of a void or debond), were clearly marked on the surface of the tip cover and were documented. These areas were checked after each day of flight operation (usually 1–2 hr of flight

time) for growth. If the flaw grew past the critical criteria, or it was determined to be unsafe, it was repaired.

## 2.2 Failure of the Honeycomb Core

**2.2.1 Description of the problem**— After about 20 hr of operational testing, approximately 12 in.<sup>2</sup> (77.42 cm<sup>2</sup>) of the core of one blade tip was found to have failed, primarily by shearing of the honeycomb through its center (fig. 9). The cause of the failure in the honeycomb core is unknown. The thin shell is highly susceptible to damage from relatively light impact and pressure, but no other failures of the honeycomb core were found in either the baseline or the alternate tips or in any other section of the blade.

**2.2.2 Inspection procedures**— Visual inspections of the surfaces of the blades and tips were performed between each flight. However, the detection of failures in the honeycomb core generally requires tap testing. For the failure noted, a small depression was visually detected near the trailing edge of the tip cover. A small tapping hammer was used to confirm and map out the suspected damaged area. Since tap testing provides information only on the boundaries of the suspect areas, and a visual inspection of the skin after paint removal did not suggest a debond between the skin and the honeycomb, the exact nature of the failure (debond or honeycomb failure) was not clear. To obtain information on the integrity of the internal structure, a computer-aided tomography (CAT) scan was performed on the tip at a nearby hospital. The CAT scan revealed the damaged core area. After the fiberglass skin was carefully removed, the core was found to have suffered extensive damage. Further inspections were performed as described in the section 2.1.2, but no other failures of the core were found.

**2.2.3 Repairs performed**— The honeycomb core was repaired by replacing the damaged core. The upper skin of the damaged area was removed by carefully grinding the skin away until the core was exposed. The damaged honeycomb was then removed and the inner surface of the lower skin was prepared by sanding and cleaning it (for bonding with the replacement core). A honeycomb plug was shaped to fit the contour of the cavity extending above the surface of the skin 0.25 in. (0.635 cm). The core was bonded to the lower skin and to the existing honeycomb core interface with Hysol EA9309.1 adhesive. After the adhesive cured, the plug was trimmed and sanded to match the upper-skin-surface contour, plus 0.020 + 0.010/–0.005 in. (0.05 + 0.025/–0.013 cm) to allow for crushing of the honeycomb when the skin is applied in accordance with the procedure recommended by the manufacturer, shown in figures 4–10 of reference 4. A skin patch was prepared with a 1-in. (2.54-cm) overlap of the repaired

area and applied to the honeycomb plug with EA9309.1 adhesive; it was clamped during curing. After curing, the clamp was removed and the patch was faired to the existing skin and refinished.

**2.2.4 Level of severity and monitoring of critical problems**— The failure of the honeycomb core was considered to be a critical problem because it reduced the strength of the tip. The same size criteria of 2.5 in. (6.35 cm) described in section 2.1.4 for debonding between the fiberglass skin and honeycomb core was also applied to failure of the honeycomb core. Monitoring was performed by tapping any suspected areas between each flight and documenting the results.

## 2.3 Failures in Fiberglass Splices

**2.3.1 Description of the problem**— After 20.1 operational hours several baseline blade tips were found to have failures in the shear splice (a good shear splice is shown in fig. 10). At 25.8 operational hours, two more splices were found to have failed. These debonds, which appeared as cracks, were found at the interface of the splice (one laminate of fiberglass-cured cloth) and the two tangs on the top and bottom of the inner surface of the tip shell (see fig. 11). Two factors contributed to the failures. First, the adhesive at the splice contained voids or did not adequately cover the mating surfaces, or second, the splice was too small and did not provide enough surface area at the interface for a proper bond. Failure in the shear web only occurred in the baseline tips because the alternate tips did not contain shear splices. Once the shear splices were properly repaired no further failures were found.

**2.3.2 Inspection procedures**— When the baseline tips were removed for maintenance or to change the tip weights, the splices were visually inspected for cracks and debonds. Inspection was performed by prying apart and/or squeezing together the upper and lower surfaces of the tip cover while visually inspecting the shear splice. Any crack or debond in the adhesive could then be readily detected. Care was taken to ensure that the inspection procedure did not damage the web. All cracks, debonds, or voids over 0.25 in. (0.635 cm) in diameter or length were repaired upon detection.

**2.3.3 Repairs performed**— Repairs were performed by replacing the existing fiberglass splice or by injecting adhesive into the failed section of the interface. Since most of the original fiberglass splices did not provide enough overlap for a good bond, the original splice was removed and a new one was fabricated to provide a 0.25-in. (0.635-cm) overlap. The original adhesive was cleaned from the web tangs, and the new splice was bonded into place with EA9309.1 adhesive; a specially

made clamp was used to hold the splice in place while it cured. In some cases where a sufficient overlap already existed the debonded area was cleaned, and either EA9309.1 or Hysol 956 adhesive was injected with a hypodermic needle into the debonded area. The new splice was then clamped and allowed to cure.

**2.3.4 Level of severity and monitoring of critical problems**– The shear splice in the XV-15 ATB baseline blade tip is not primary flight structure. It is a secondary structure web used to prevent damage to the tip cover during handling and when the tip is removed or installed. All failures of the tip splice had a bond area less than 0.25 in. (0.635 cm) in width. A 0.25-in. (0.635-cm) crack is allowed in the chordwise direction, for the small voids in the adhesive which may form during assembly or repair of the splice. Because the loads during flight are carried by the fasteners into the spar, it is not expected that a crack will grow during flight. If a crack or debond in the web is less than 0.25 in. (0.635 cm) long in the chordwise direction, it is monitored and repaired during the next convenient maintenance period. All the noncritical cracks and debonds are recorded and visually inspected for growth each time the tip cover is removed.

## 2.4 Cracks in the Fiberglass Blocks

**2.4.1 Description of the problem**– Before the first flight on the aircraft, many cracks were found in the fiberglass blocks at the interface between the molded weight blocks of each tip-weight-fitting assembly where they are bonded together (fig. 12). Throughout the flight-test activity, the blocks continued to be plagued by cracks at various bond-line locations. Various types of adhesives and repair methods were tried. Since the weight blocks are secondary structure (the weight blocks are held together by fiberglass wraps from the main spar), this problem was not a safety issue. Some of the cracks were caused by the inadvertent use of over-length fasteners, which pushed against a mating block and caused the blocks to separate. Most cracks were formed when the adhesive between the blocks failed during flight or upon assembly. The adhesive at the block interfaces may have squeezed out during curing, causing inadequate bonding of the blocks. Another possibility is that the adhesive did not cure properly or was under-strength during assembly, resulting in lower strength of the interface. A repair procedure was established in which a high-strength adhesive with a long cure time was used, coupled with a procedure to prevent the crack from fully closing during the cure cycle, which ensured that the thickness of the adhesive would be adequate for maximum strength. None of the repaired blocks had further failures.

**2.4.2 Inspection procedures**– Each time the tips were removed for maintenance or to change the tip weights for blade balance adjustments, a visual inspection of the tip-weight-fitting-assembly fiberglass blocks was performed. Many cracks were easily visible, but cracks that were not visible could be found by causing them to open by applying pressure either by squeezing or by opening the weight cavity. Shining a strong light through the block often helped to highlight the crack.

**2.4.3 Repairs performed**– All the cracks were at the interface of assembly components, and were repaired by bonding the components. The cracks were opened slightly with a small wedge, and Hysol EA954 adhesive was injected into the crack. The wedge was left in place during curing to prevent the adhesive from being squeezed out. The wedge was then removed, and the tip was replaced.

**2.4.4 Level of severity and monitoring of critical problems**– Cracks in the fiberglass blocks were not considered to be a critical problem because these blocks were not primary structure (primary retention is provided by the spar extension wraps). The area was therefore inspected for cracks only when the tip caps were removed for maintenance. Any cracks found were repaired before the next flight.

## 2.5 Misalignment of Mated Composite Parts

**2.5.1 Description of the problem**– One case of misalignment of mated composite parts occurred, with the alternate tips. They had been initially fitted to the blades in 1987 prior to flight, and then were returned to the manufacturer for completion and finishing; they had not been installed on the blades for over two years. Figure 13 shows how the tip cap fits over the weight cavity onto the blade. When the tips were to be installed on the blades they would no longer fit because of interference at the interface, which resulted in the screw holes not lining up with the screw insert locations on the spar. It appeared that either the ends of the blades had changed shape during flight testing, or the mating contour of the tips had been changed during the finishing process. Modifications (by the addition or removal of material) of the alternate tips were required to fit them on the blades, and no further fitting problems were encountered.

**2.5.2 Inspection procedures**– When the alternate tips were fitted to the blades, the misalignment was easily seen. After the tips were modified, further close visual inspections were performed when the tips were removed and installed to insure proper tip fit.

**2.5.3 Repairs performed**– The tips were reworked by removing material from the mating surfaces as required to provide proper fit. If a filler was required, a thin layer of

EA9309.1 adhesive was used. If a thick buildup was required, a few laminates of fiberglass were bonded in with the adhesive.

**2.5.4 Level of severity and monitoring of critical problems**— Constant monitoring was necessary to ensure the proper installation of the tip and to maintain correct airflow at the interface. All interfaces were checked visually each time the tips were removed and reinstalled.

## 2.6 Failures of Retention of Metal Fasteners

**2.6.1 Description of the problem**— There were three major types of problems associated with the metal fasteners in the fiberglass on the ATB blades. These problems involved the locking-key inserts, the use of helicoils, and the dimpled washers. Figure 14 shows a typical fastener, locking-key insert, and dimpled washer.

The most common fastener problem was associated with the locking-key inserts located at the outboard end of the main body of the blade in the spar and in the tip weight fitting. Problems included: (1) damage to the fiberglass threads in which the insert is seated; (2) failure of the adhesive, or lack of adhesive, at the interface of the insert and fiberglass; and (3) failure of the fiberglass in the vicinity of the insert. After 25.8 hr of flight time, an insert was found to have pulled loose from the fiberglass nose block. The failure of the insert in a fiberglass block was discovered during a post-flight inspection; it was manifested as a bulge in the skin, about 0.0625 in. (0.159 cm) high, at one of the outboard fastener locations. When the insert was removed it was found to have been fastened with adhesive into a hole in the fiberglass. Apparently the original threaded hole had been too large, so it was drilled out and the insert was glued in place. The glue alone does not provide the retention strength that threads in the fiberglass do. Further inspection showed no other inserts with this deviation; however, a torque test identified a number of inserts that were also loose. Loads and vibration caused the threads in the fiberglass to deform slightly, which loosened the inserts. The inserts were removed and reinstalled with adhesive so that they were securely bonded to the fiberglass threads.

Originally the end of the blades had helicoils for the retention screws of the tip covers. However, after the first non-flight tests with the blades, a number of helicoils had failed. It was determined that helicoils were insufficient because the screws used contained an elastomeric locking device. The friction from this locking feature tended to drag the helicoil inserts, rotating them during installation and removal and thereby damaging the threads. Before the first flight they were replaced with the locking-key inserts now used.

The third problem was with the dimpled washers that are bonded to the skins of the blade and tip beneath the countersunk heads of the retention screws. On some occasions a washer had debonded from the surface of the tip cover. Twisting or warping of the tip had placed high shear loads at the interface of the washer, causing the adhesive to fail. In some cases, the fiberglass skin under the dimpled washer was too thin, and there was a gap at the interface between the tip cover and the blade surface. When the fasteners were torqued down, the surface in the vicinity of the washer warped, causing the bond of the washer to fail. The washer was replaced and the skin under the washer was built up with fiberglass when necessary.

Another problem associated with the dimpled washers was detected during preflight inspections early in the test program. When the tips were installed after maintenance, the retention screws were torqued to the specified values. Typically, one or more days after installation, the torques were rechecked in preparation for a flight test and were found to be below the required levels. After the screws were retorqued, further reductions were detected on subsequent checks a day later. Each time the tips were installed, this problem occurred. Smaller readjustments to the screw torques were required from time to time until the levels remained within the specified range. It was determined that the fiberglass skin in the vicinity of the washers was demonstrating a viscoelastic behavior. The application of the load on the washers caused the material to “flow” enough to relieve the load. The problem was resolved by changing from the initial washer design, which fit only below the head of the countersunk fastener, to a type that includes a flat shoulder (shown in fig. 14) which reduced the local stresses to a level where the viscoelastic property was not a factor in retaining the proper torque.

**2.6.2 Inspection procedures**— A visual inspection was performed on all the metal fasteners visible on the surface of the blade after every flight. The metal fasteners located in the tip weight fitting or under the tip cap were visually inspected when the tips were removed for changing the tip weights or for maintenance. If it was suspected that an insert was loose, a torque test was performed and/or a short fastener with the same threads as the insert was inserted (fig. 15) and, using light pressure (pushing on the fastener too hard could damage the fiberglass threads), the fastener was wiggled laterally by hand while a visual examination was made of the interface of the insert and the fiberglass for unusual movement, debonds, or cracks in the fiberglass. The insert was then replaced, if necessary.

A visual inspection of the dimpled washers was made for loose or “popped-up” washers, or damage to the adjacent



fiberglass. All washers were replaced as necessary. The replacement of the helicoils with standard locking-key inserts has eliminated helicoil failures.

**2.6.3 Repairs performed**— All the failed metal fasteners were replaced as soon as they were detected. The loose inserts were replaced by removing the insert from its cavity either by pulling it directly out of its hole if the fiberglass threads were badly damaged, or, if the threads were not badly damaged, by knocking the insert's "keys" down into the cavity below the insert so that the insert was free to be twisted out. A new insert was then glued in place with EA9309.1 adhesive. If there was damage to the threads in the fiberglass structure, they were sanded out and the hole was drilled oversize and cleaned. The hole was then coated with adhesive and lined with three layers of fiberglass cloth saturated with the same adhesive, with the first and third layers at 0/90 deg and the second layer at  $\pm 45$  deg. Pressure was applied to the fiberglass using a tapered plastic dowel inserted into the hole. After the adhesive cured, the hole was drilled and tapped using a guide to ensure perpendicularity to the surface of the tip. A new locking-key insert was installed with adhesive.

The unbonded dimpled washers were removed and the dimple in the fiberglass skin was cleaned and sanded. The depression in the fiberglass was built up with a mixture of chopped fiberglass cloth and EA9309.1 adhesive. The bonding surfaces of the washers were etched, primed, and coated with adhesive, and the washers were bonded to the blade.

**2.6.4 Level of severity and monitoring of critical problems**— All of the fastener problems were determined to be critical and were repaired before the next flight. Failure of the insert or washers could cause the fastener to shake loose or crack the adjacent fiberglass structure.

### 3. Lessons Learned

After examining the composite blade repairs performed and their associated problems, it was determined that the following measures could be helpful in preventing future problems of the same type.

1 Composite blade designs should have as few components as possible. The large number of components contributed to the amount of repair work required on the blades. The removable blade tips and the ability to make weight changes on the ATBs were required; however, simplicity and a reduction of the number of individual components (such as the number of fasteners, and individual-part components) would reduce the amount of maintenance required.

2. A sturdier structural design should be considered for "thin-walled blade tips" that are tested in a new aerodynamic environment and require frequent handling. The thin-shelled honeycomb structure was designed to withstand predicted aerodynamic loading. However, the thin-shelled tips were removed often for blade weight changes and maintenance, and the extensive handling and/or unknown flight loads could have weakened them. The thin-shell baseline tip was also made of more components than the solid-honeycomb alternate tip, which gave it more possibilities for failure, such as the failure of the shear splices in the tip and failure of the thin honeycomb core.

3. The selection and application of adhesives in a honeycomb blade is critical and must be monitored carefully. During design and repair with adhesives, the strength of the adhesive is not the only thing that must be checked carefully. The environment in which the adhesive is to be used, the type of handling the adhesive is exposed to, and the compatibility of the adhesive with the material it is bonded to must be carefully considered. Also, the thickness of adhesive required and the forces placed on the mated parts being glued must be checked carefully.

4. Metal fasteners in composites require different maintenance and inspection techniques than fasteners used in metal structures. Most of the problems associated with fasteners were caused by the fact that the metal fasteners are much harder than the fiberglass material, and may cause damage or deformation to the composite.

5. The use of a mechanical tap tester with an electronic readout will help alleviate the subjectivity associated with a manual method, e.g., coin or tapping hammer. Finding and mapping voids and debonds in the composite honeycomb structure with precision using a coin or tapping hammer is difficult. The use of an electronic tapper with its precise readout will alleviate this difficulty. By comparing the electronic readout of a suspected debond or damaged area with an electronic readout from a known specimen, e.g., a debond in a 0.25-in. (0.064 cm) sample, more reliable and reproducible damage detection can be achieved.

6. Thorough training in composite repairs will greatly reduce maintenance time spent on repairing composite blades. Much time was spent learning about repair procedures and the limits of the flaws encountered on the blades. Better training would reduce this time.

7. Better quality control is important during all phases of the project—manufacturing, daily use, and maintenance. Close attention to the use of adhesives during fabrication and repair, better checks on installation of the fasteners in the fiberglass components, and closer

inspection during the manufacturing process and during repairs and maintenance will improve productivity.

#### 4. References

1. Alexander, H. R., Maisel, M. D., and Giulianetti, D. J.. The Development of Advance Technology Blades for Tiltrotor Aircraft, Eleventh European Rotorcraft Forum Paper No. 39, Sept. 1985.
2. Smith, K. E., Alexander, H. R., and Maisel, M. D.. Design Aspects of the XV-15 Advanced Technology Blade Program, American Helicopter Society Annual Forum, May 1985.
3. Mitsui Engineering & Ship-building Co., Ltd, Woodpecker, WP632 Tapping Exfoliation Detector Brochure (no date).
4. Boeing Vertol Company, Installation, Inspection, Maintenance, and Repair of XV-15 Advanced Technology Blade, Document D210-12340-1, October 1984.

ORIGINAL PAGE  
BLACK AND WHITE PHOTOGRAPH



FIGURE 1. XV-15 tiltrotor aircraft

ORIGINAL PAGE  
BLACK AND WHITE PHOTOGRAPH

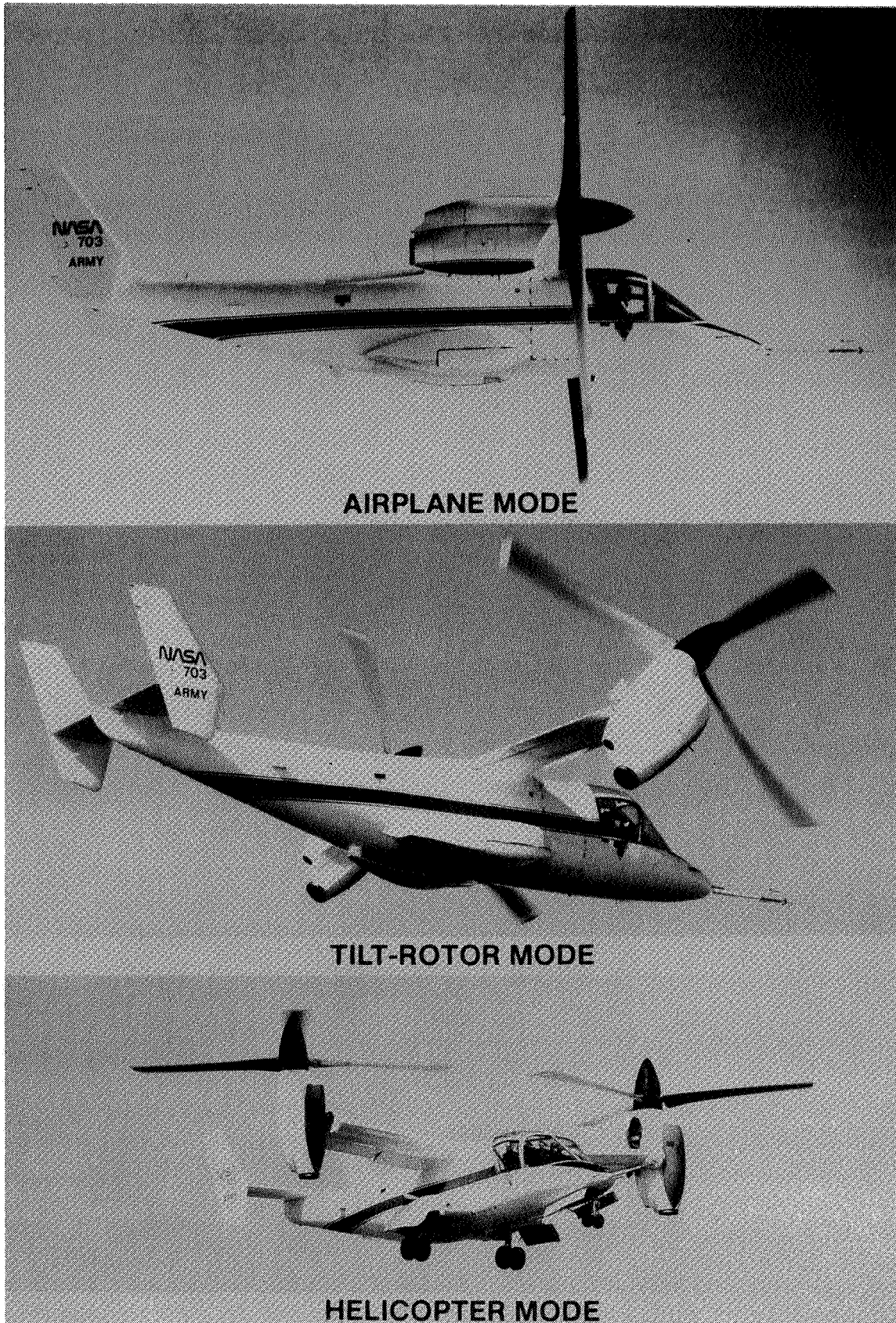

FIGURE 2. XV-15 conversion modes

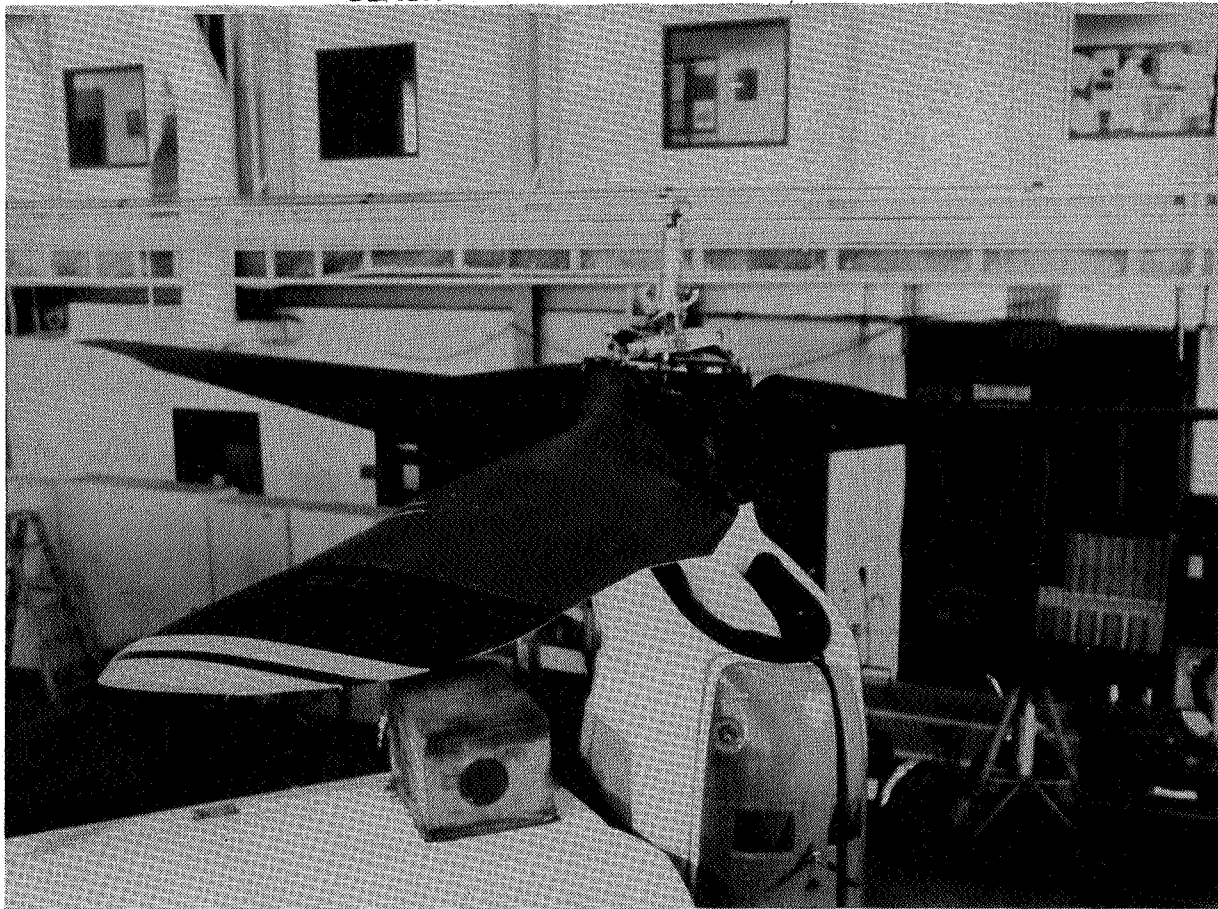

FIGURE 3. ATBs on aircraft

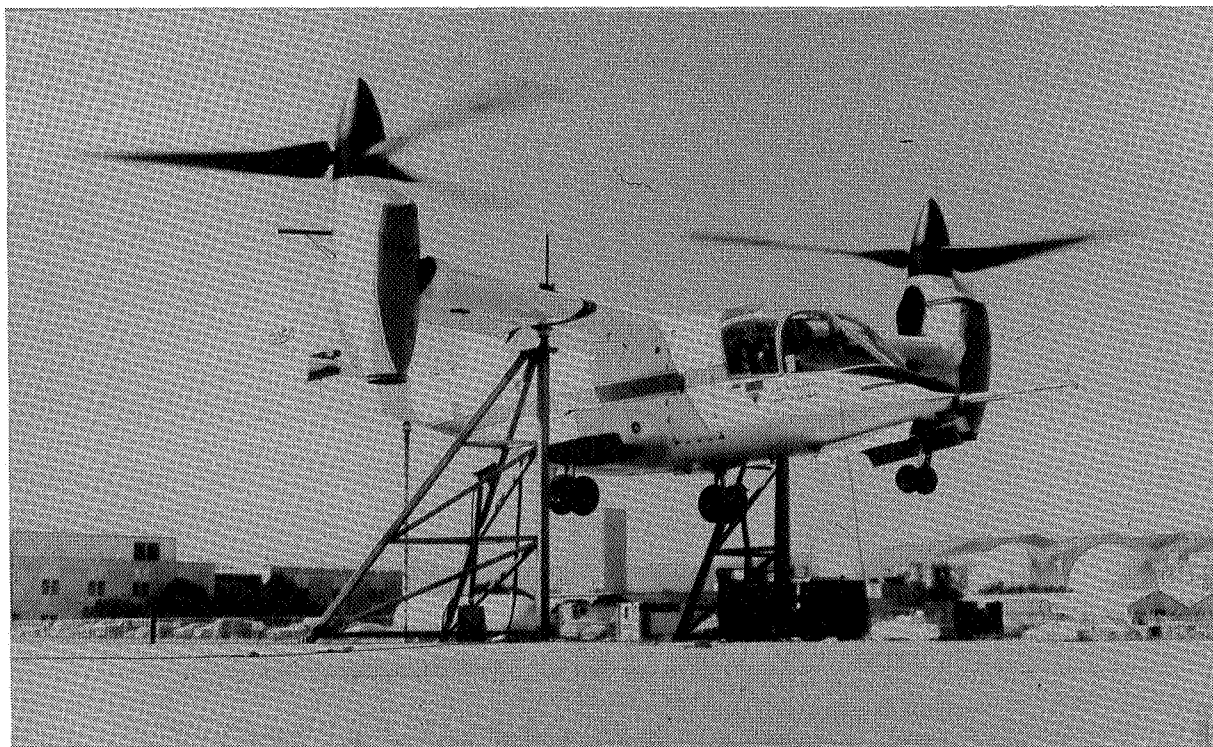

FIGURE 4. XV-15 on hover test stand

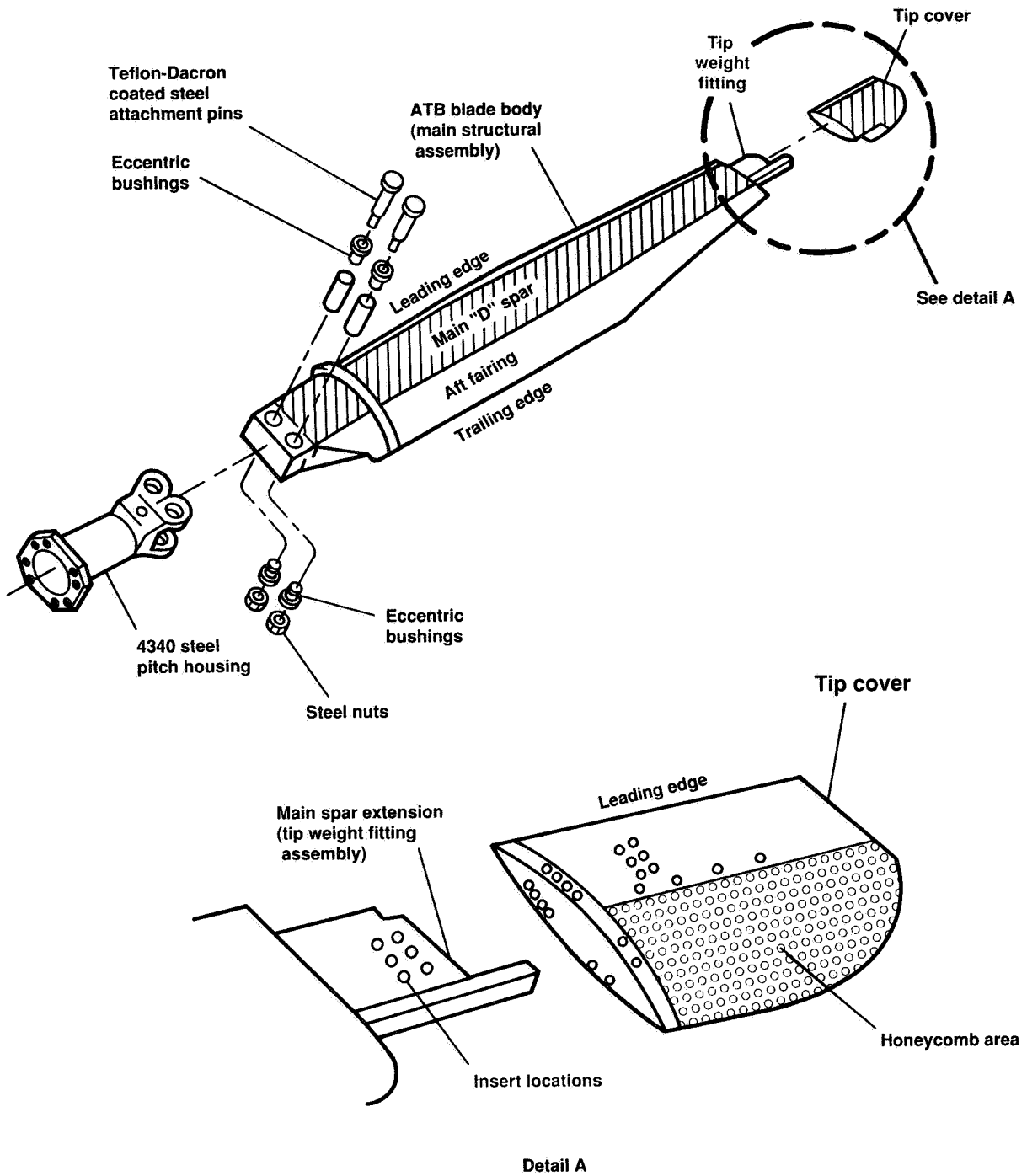

FIGURE 5. Composite advanced technology blade (ATB) detail

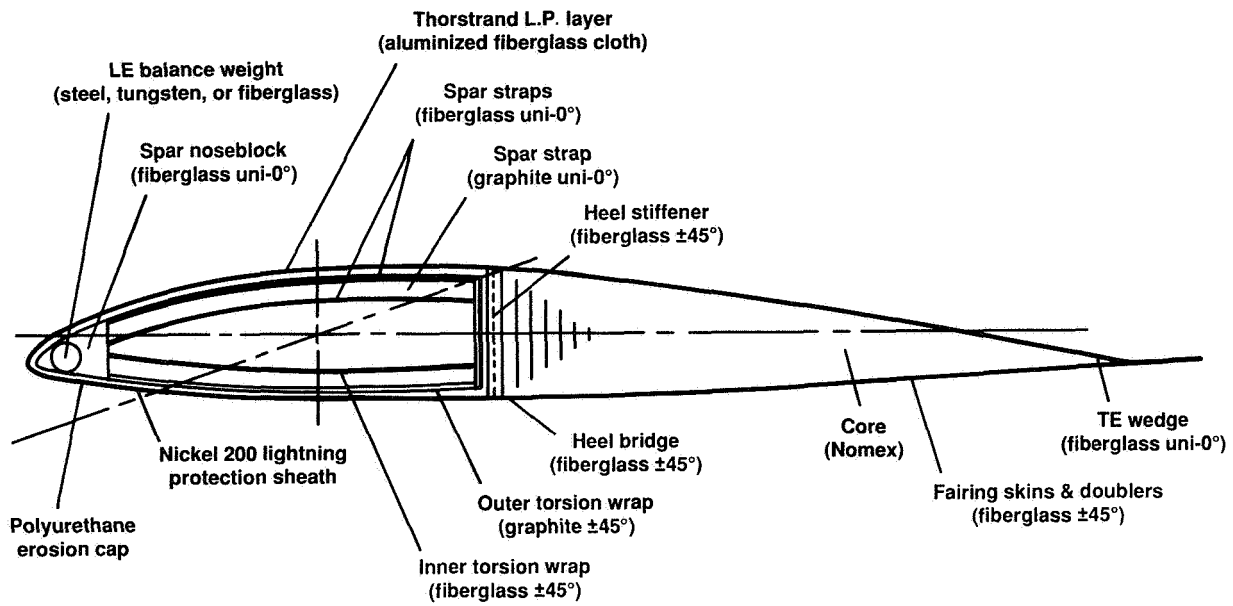

FIGURE 6. ATB main structural assembly cross section

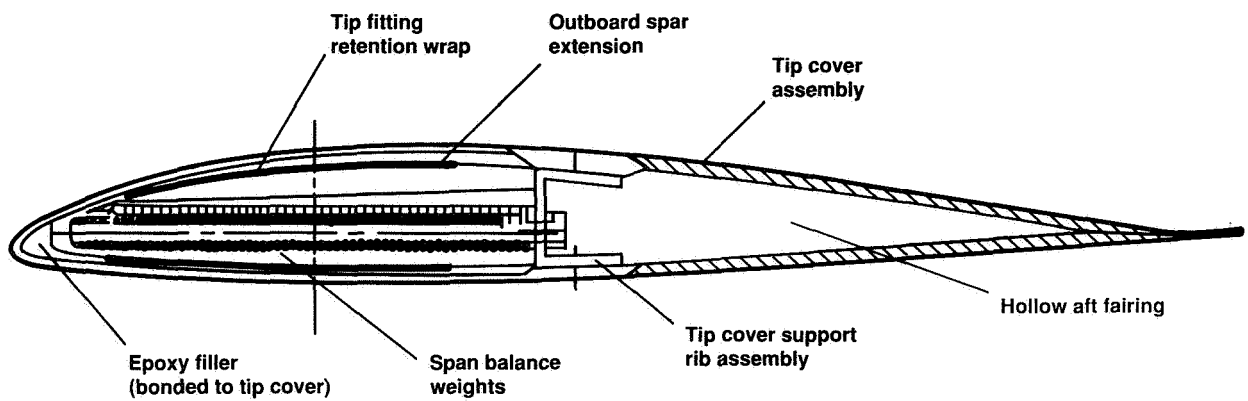

FIGURE 7 ATB tip-cover cross section

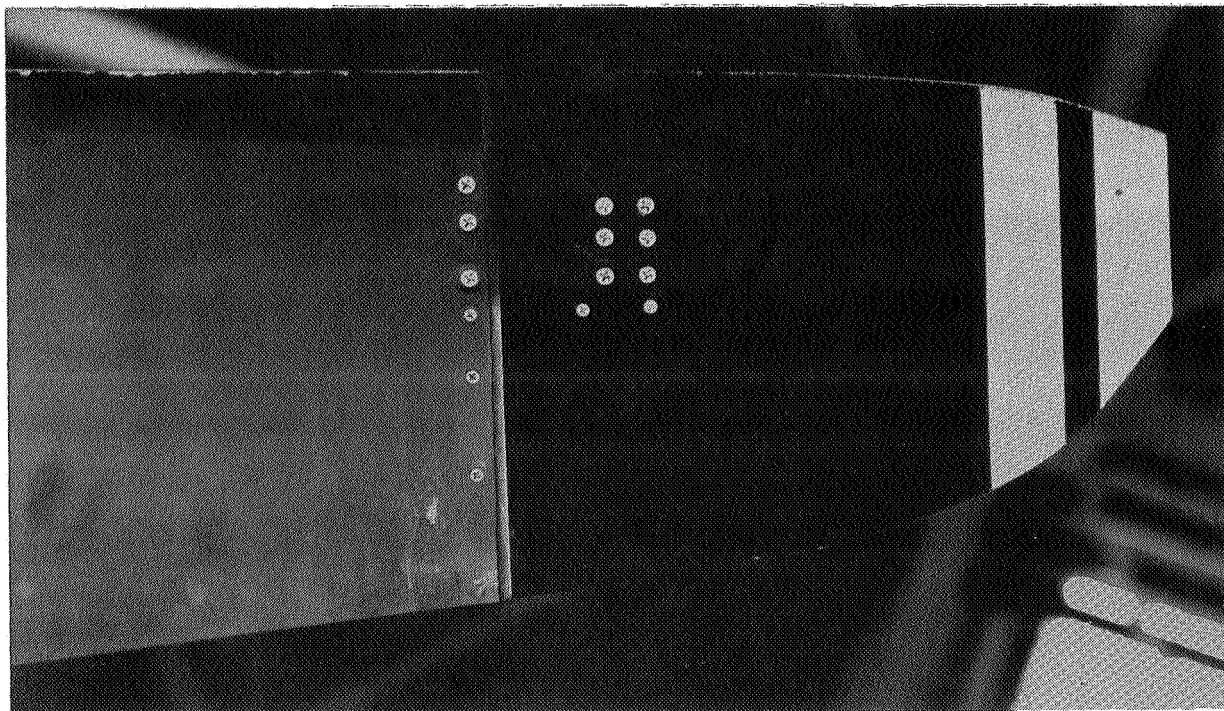

FIGURE 8. Retaining-screw locations on end of blade and tip cover

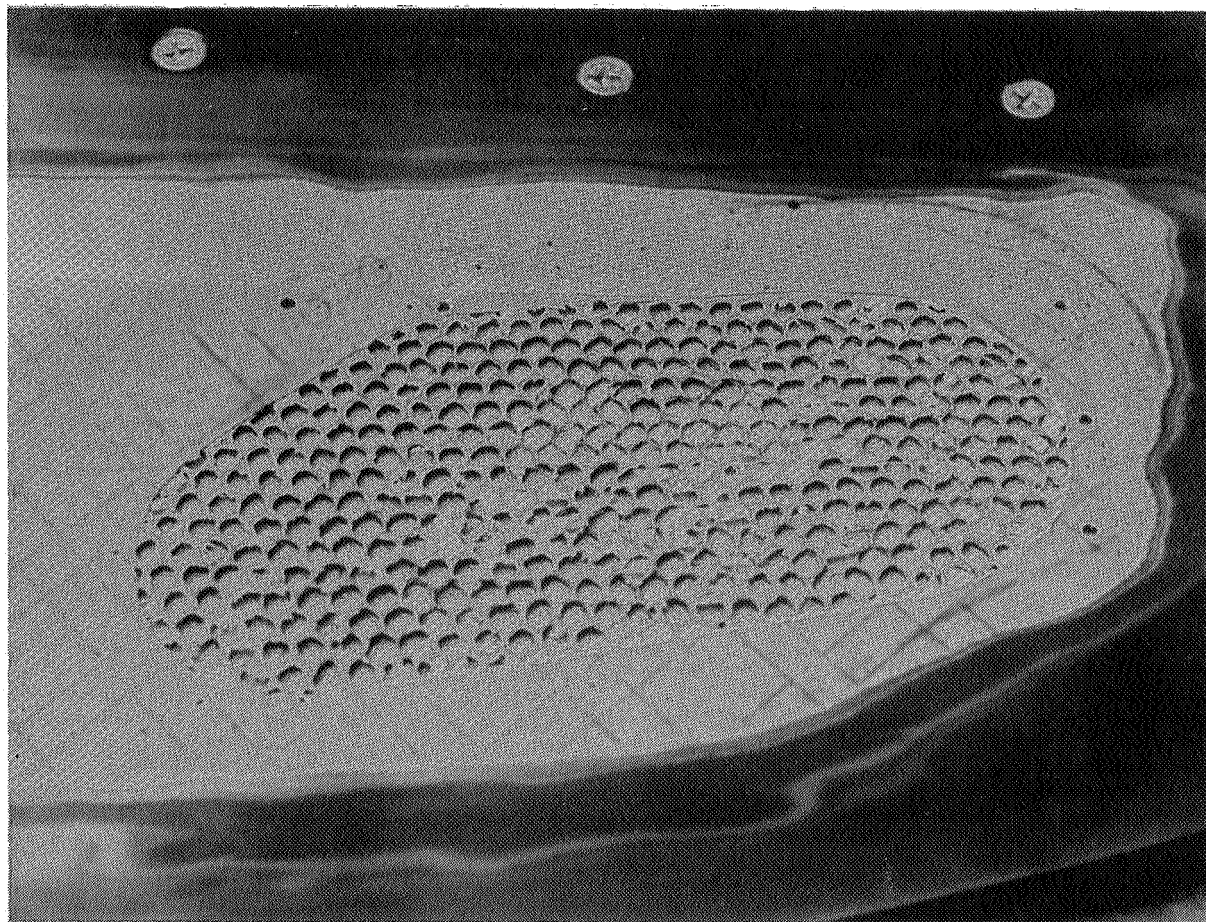

FIGURE 9. Failure of honeycomb core (skin removed)

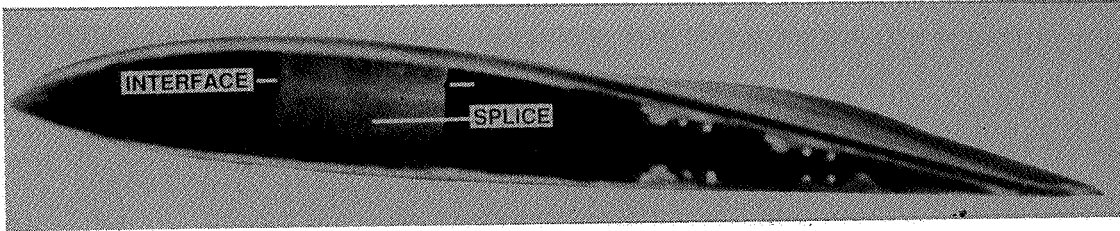
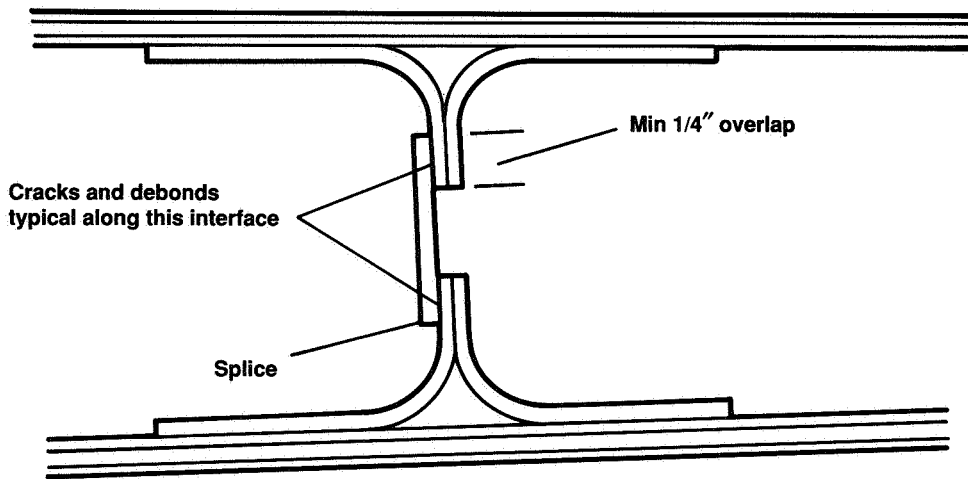
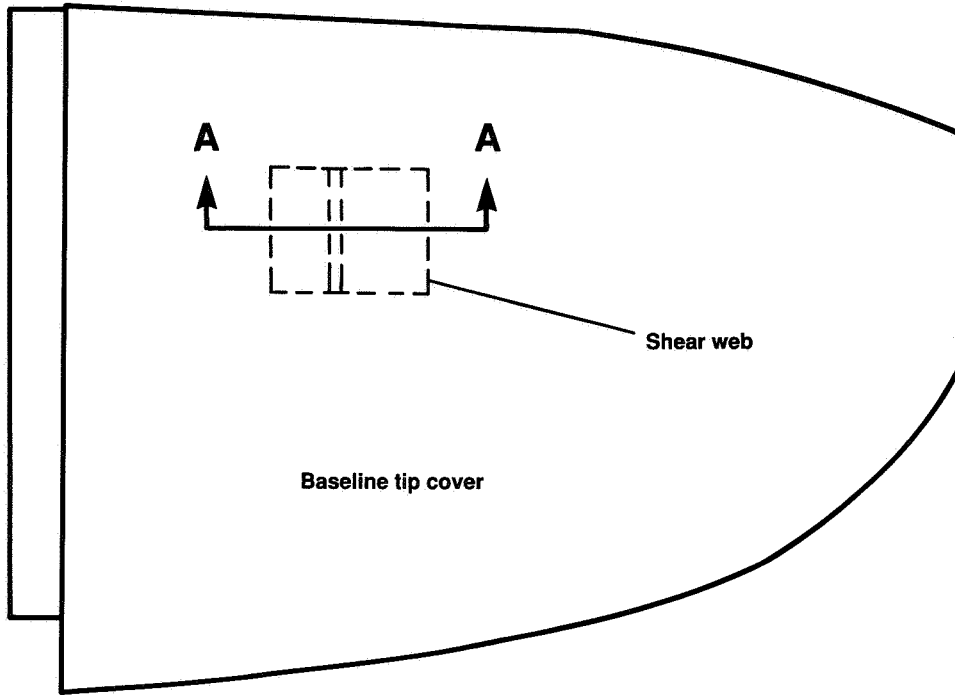

FIGURE 10. Location of shear splice in baseline tip cover



A-A

FIGURE 11. Detail of shear splice in baseline tip cover



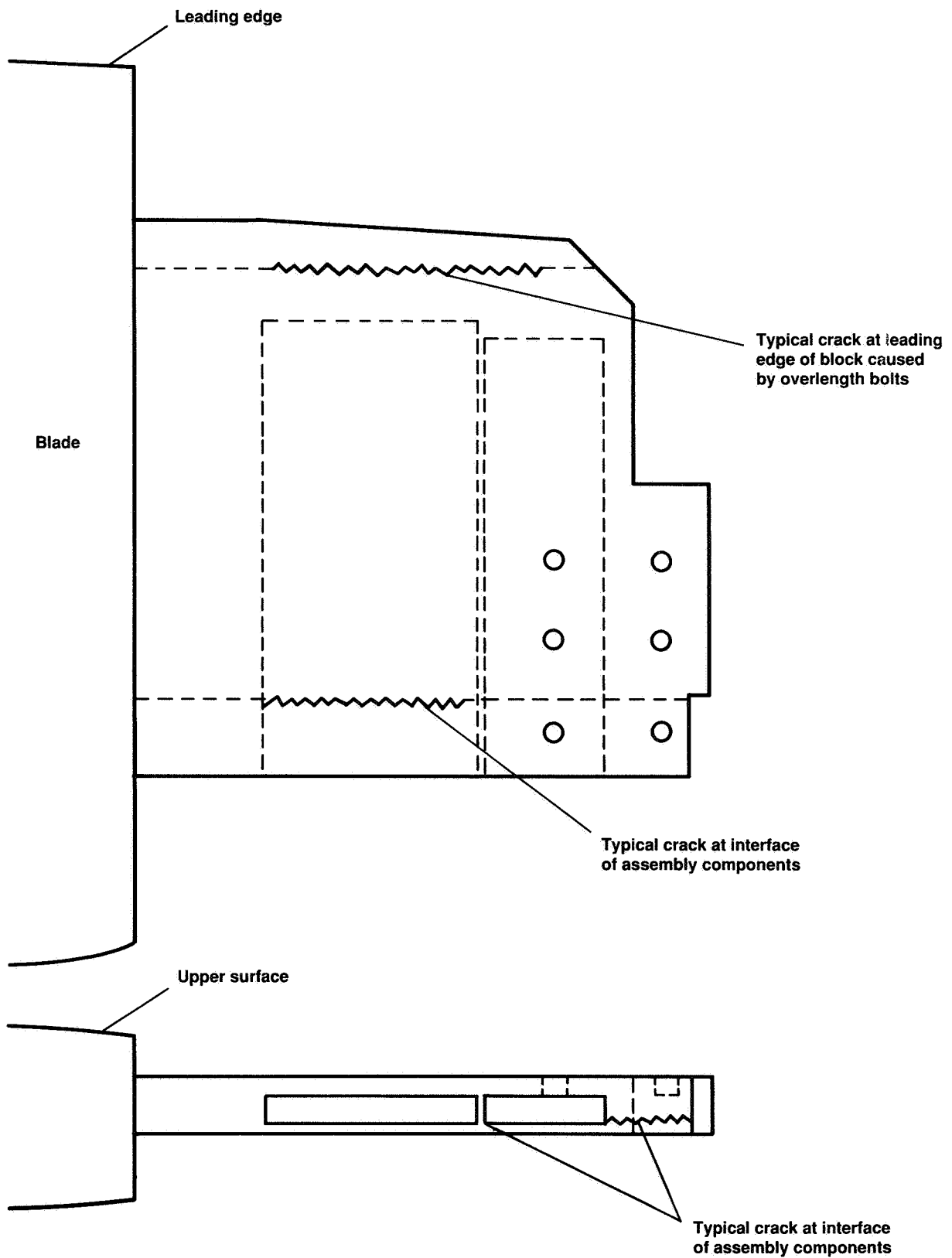

FIGURE 12. Typical cracks in tip-weight-fitting assembly

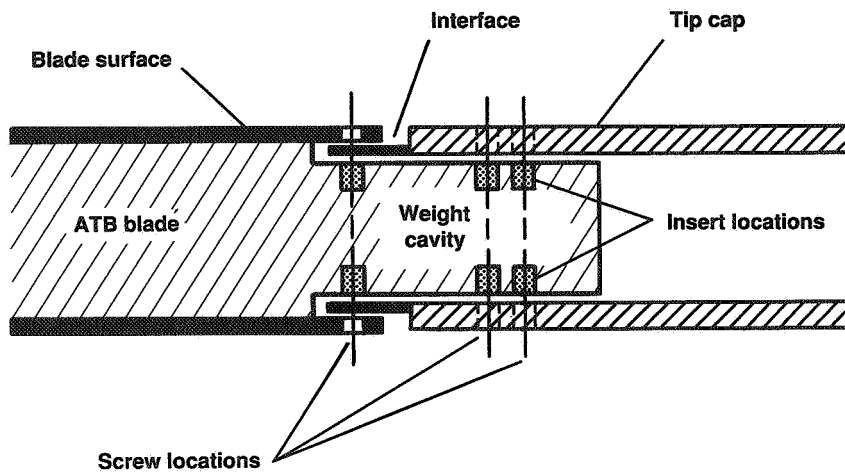

FIGURE 13. Interface of blade and tip cover

ORIGINAL PAGE  
BLACK AND WHITE PHOTOGRAPH

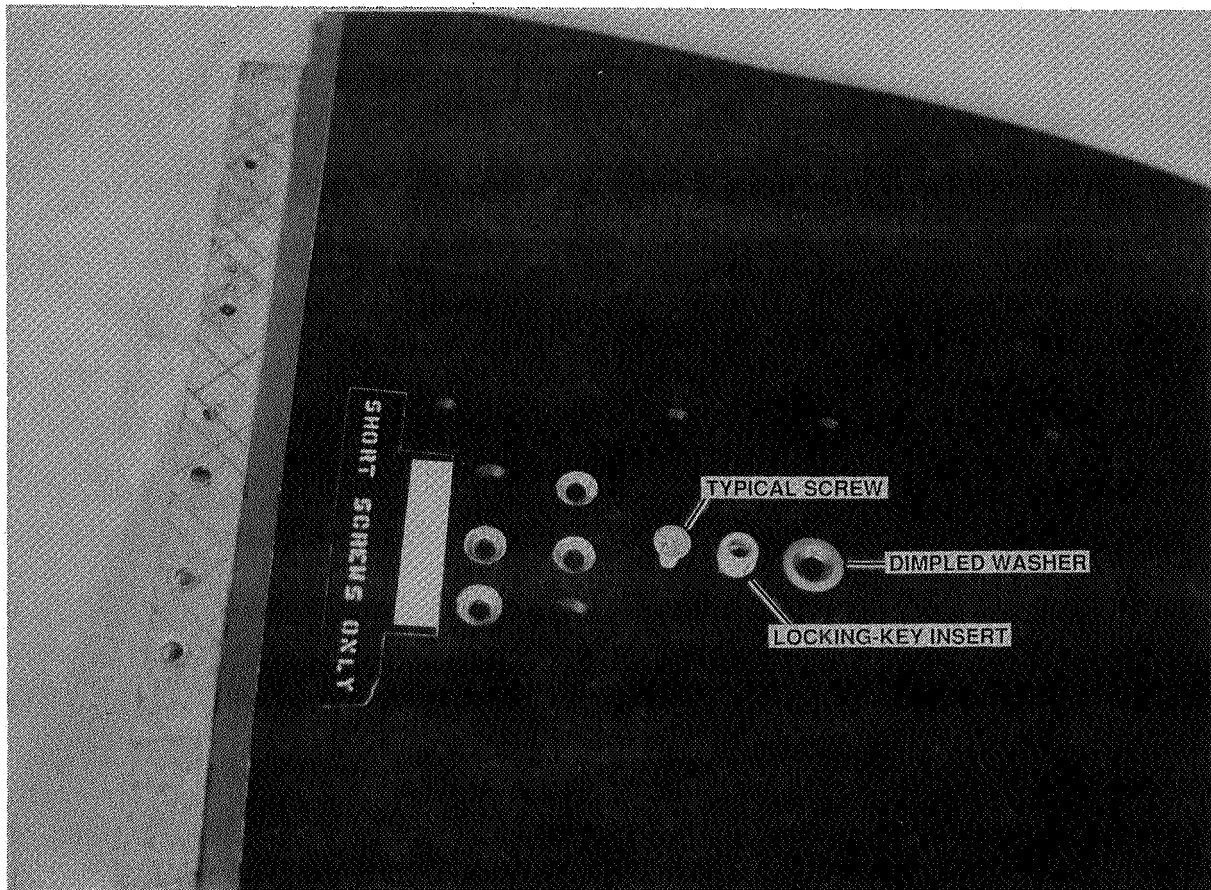

FIGURE 14. Metal fasteners currently used in ATB blade and tip-cover structure

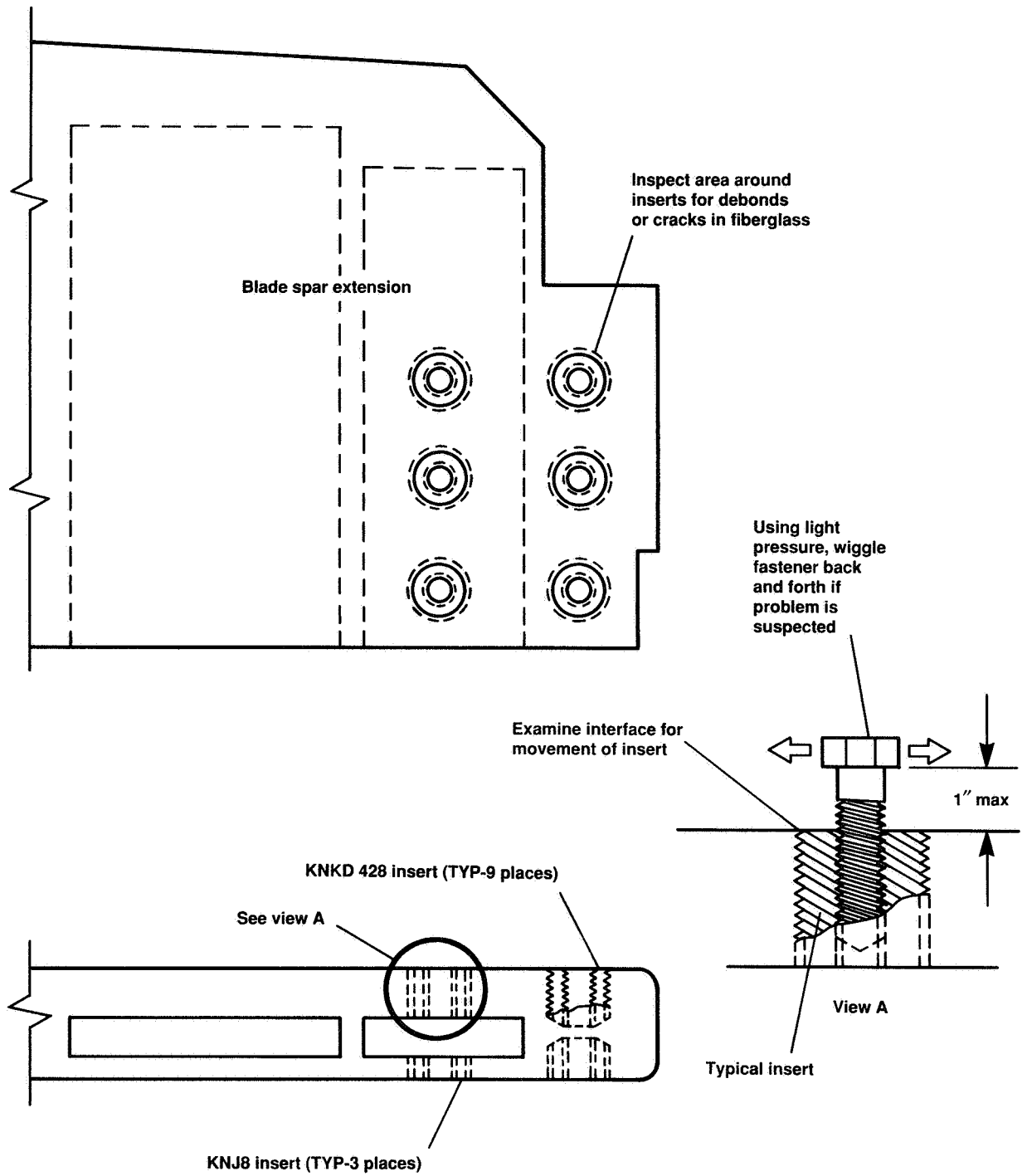

FIGURE 15. Inspection of inserts in spar extension and end of blade

# REPORT DOCUMENTATION PAGE

*Form Approved*  
OMB No. 0704-0188

Public reporting burden for this collection of information is estimated to average 1 hour per response, including the time for reviewing instructions, searching existing data sources, gathering and maintaining the data needed, and completing and reviewing the collection of information. Send comments regarding this burden estimate or any other aspect of this collection of information, including suggestions for reducing this burden, to Washington Headquarters Services, Directorate for Information Operations and Reports, 1215 Jefferson Davis Highway, Suite 1204, Arlington, VA 22202-4302, and to the Office of Management and Budget, Paperwork Reduction Project (0704-0188), Washington, DC 20503.

1. AGENCY USE ONLY (Leave blank)	2. REPORT DATE December 1991	3. REPORT TYPE AND DATES COVERED Technical Memorandum	
4. TITLE AND SUBTITLE Tiltrotor Research Aircraft Composite Blade Repairs – Lessons Learned		5. FUNDING NUMBERS  505-61-51	
6. AUTHOR(S)  Paul S. Espinosa and David R. Groepler			
7. PERFORMING ORGANIZATION NAME(S) AND ADDRESS(ES)  Ames Research Center Moffett Field, CA 94035-1000		8. PERFORMING ORGANIZATION REPORT NUMBER  A-91189	
9. SPONSORING/MONITORING AGENCY NAME(S) AND ADDRESS(ES)  National Aeronautics and Space Administration Washington, DC 20546-0001		10. SPONSORING/MONITORING AGENCY REPORT NUMBER  NASA TM-103875	
11. SUPPLEMENTARY NOTES This report was presented at the Eighth International Conference on Composite Materials, Honolulu, July 1991 Point of Contact: Paul S. Espinosa, Ames Research Center, MS 237-5, Moffett Field, CA 94035-1000 (415) 604-3150 or FTS 464-3150			
12a. DISTRIBUTION/AVAILABILITY STATEMENT  Unclassified-Unlimited Subject Category – 05		12b. DISTRIBUTION CODE	
13. ABSTRACT (Maximum 200 words)  The XV-15, N703NA Tiltrotor Research Aircraft located at the NASA Ames Research Center, Moffett Field, California, currently uses a set of composite rotor blades of complex shape known as the advanced technology blades (ATBs). The main structural element of the blades is a D-spar constructed of unidirectional, angled fiberglass/graphite, with the aft fairing portion of the blades constructed of a fiberglass cross-ply skin bonded to a Nomex honeycomb core. The blade tip is a removable laminate shell that fits over the outboard section of the spar structure, which contains a cavity to retain balance weights. Two types of tip shells are used for research. One is highly twisted (more than a conventional helicopter blade) and has a hollow core constructed of a thin Nomex-honeycomb-and-fiberglass-skin sandwich; the other is untwisted with a solid Nomex honeycomb core and a fiberglass cross-ply skin. During initial flight testing of the blades, a number of problems in the composite structure were encountered. These problems included debonding between the fiberglass skin and the honeycomb core, failure of the honeycomb core, failures in fiberglass splices, cracks in fiberglass blocks, misalignment of mated composite parts, and failures of retention of metal fasteners. Substantial time was spent in identifying and repairing these problems. This paper discusses the types of problems encountered, the inspection procedures used to identify each problem, the repairs performed on the damaged or flawed areas, the level of criticality of the problems, and the monitoring of repaired areas. It is hoped that this discussion will help designers, analysts, and experimenters in the future as the use of composites becomes more prevalent.			
14. SUBJECT TERMS  Tiltrotor, Advanced technology blades, XV-15, XV-15 composite blade repairs		15. NUMBER OF PAGES 18	16. PRICE CODE A02
17. SECURITY CLASSIFICATION OF REPORT Unclassified	18. SECURITY CLASSIFICATION OF THIS PAGE Unclassified	19. SECURITY CLASSIFICATION OF ABSTRACT	20. LIMITATION OF ABSTRACT