

FINAL REPORT

**Design of Biomass Management Systems and Components
for Closed Loop Life Support Systems**

to the

National Aeronautics and Space Administration
and the
Universities Space Research Association

describing

1990-1991 University of Florida Participation

in the

NASA\USRA Advanced Design Program

June 1991

Instructor

Dr. Gale E. Nevill, Jr.
Department of Aerospace Engineering,
Mechanics and Engineering Science
University of Florida
Gainesville, Florida 32611
(904) 392-0889

ACKNOWLEDGEMENTS

The success of the 1990/91 Engineering Design course has been due in considerable part to the contributions of Mr. Bill Martin, Dr. William Knott, Dr. John Sager and Mr. Dennis Chamberland of NASA/KSC. In addition, Mr. Jack Sevier, Ms. Carol Hopf, Ms. Barbara Rumbaugh and Ms. Sue McCown of USRA gave valuable and much appreciated help. Finally, the excellent help of Mr. Barry Finger and Mr. Ronnie Rodriguez, the teaching assistants, the contribution of Dr. Yechiel Crispin, plus the support of numerous students from previous classes and faculty and staff from throughout the University of Florida is gratefully acknowledged.

TABLE OF CONTENTS

	Page
INTRODUCTION	1
DESIGN PROJECT DESCRIPTIONS	2
SUMMARY	3
APPENDIX A	EGM 4000 Class Report, <u>Preliminary Design of a Biomass Management System for Use in a Closed-Loop Life Support System</u> , December 1990
APPENDIX B	EGM 4001 Class Report, <u>Design of Components for Biomass Management in a Closed-Loop Life Support System</u> , May 1991

INTRODUCTION

For a number of years the eight semester credit Engineering Design sequence, EGM 4000/4001, has been project oriented and taught by Dr. Gale E. Nevill, Jr. on a cooperative basis with representatives of industry and various government agencies and laboratories. For the past six years this sequence has been taught in cooperation with personnel from the NASA/KSC/CELSS project with support from a NASA/USRA Advanced Space Design Program grant. This year the cooperation has continued with the University of Florida having Sustaining status in the Advanced Design Program.

Planning for this year's course took place in the spring and summer of 1990 with discussions between Dr. Nevill and Mr. Barry Finger of the University of Florida and Mr. Bill Martin, Dr. John Sager, Mr. Dennis Chamberland and Dr. William Knott of NASA/KSC. The course began with a presentation to the class in Gainesville by Messrs. Knott, Sager and Chamberland regarding the nature and needs of the NASA/KSC Controlled Ecological Life Support System (CELSS) program. Communication between class members and KSC personnel was maintained by frequent telephone contact and regular visits by KSC personnel to the University campus. Mr. Dennis Chamberland served as the principal KSC contact in support of class activities. In addition to the informal visits, KSC and BIONETICS personnel also were present for formal oral presentations of achievements at the end of each semester. Communication was also strengthened by a class visit to KSC in the Fall semester of 1990. This provided an opportunity for a general tour of KSC, for a more detailed familiarization with the CELSS project and for personal meetings with several CELSS project personnel who had not been to campus.

During the first semester (EGM 4000) focus was on learning general principles and techniques of design, both through work on the main class project and a number of smaller "over the weekend" type projects. The instructor served as project leader during the very early part of the semester; later students served as project and group leaders on a rotating basis, thus giving all class members an opportunity for some leadership experience.

During the second semester (EGM 4001), focus was on learning to design, actually fabricate and test small components and subsystems, thus adding considerable realism to the students experience. The students were responsible for planning and managing each of the projects initiated and for making regular oral progress reports, submitting regular written progress reports, presenting a final oral briefing and preparation of a comprehensive final written project report.

DESIGN PROJECT DESCRIPTIONS

During the first semester the class focused on management of the biomass (edible and inedible) produced by a regenerative system for growing higher plants in space during long duration missions. Effort was devoted to clarifying system requirements, to organizing and conducting the learning required by the project, and to identifying promising specific project areas. The class was then divided into four teams which explored and did preliminary design studies on (1) planting and harvesting, (2) food management, (3) resource recovery, and (4) refurbishing needs associated with biomass management. The results of the first semesters work are presented in the EGM 4000 class final report, dated December 1990, titled Preliminary Design of a Biomass Management System for Use in a Closed-Loop Life Support System which is included as Appendix A.

The work of the first semester clarified the four design problem areas and provided the basis for choosing projects for the second semester. For the second semester, three of these areas were selected as most promising for detail component design, prototype fabrication and testing. The second semester design projects chosen were:

- aeroponic nutrient delivery and automated chamber refurbishment system,
- biomass transport and transfer container, and
- work-through air curtain particle controller.

The students were divided into three groups and each group, developed design specifications, created a detailed design to satisfy the specifications (in most cases created numerous designs), and built prototypes and tested them. The results of these efforts are described in the EGM 4001 class second semester report, dated May 1991, titled Design of Components for Biomass Management in a Closed-Loop Life Support System, which is included as Appendix B.

SUMMARY

The 1990-91 EGM 4000/4001 Engineering Design course, with cooperation from NASA/KSC personnel and support from the USRA/University Advanced Space Design Program, was clearly successful. In this course the students were provided with a highly motivating opportunity for in-depth involvement in real, complex and important design problems. They benefitted from extensive interaction with NASA professional and technical personnel and had opportunities to visit NASA Centers and broaden their technical and professional horizons. The students were able to develop a sound working knowledge of design principles and methodologies, gain project organization and leadership experience under realistic conditions, develop skills at oral presentation and report writing and learn about the realities of trying to actually fabricate a working prototype of a design. Finally, they were able to obtain the maturity, self-confidence and satisfaction of doing professional level technical work.

NASA also is believed to have benefitted significantly from this cooperative venture, by the strengthening of the design capabilities of a number of promising students, by contact with and close knowledge of a number of potential professional employees and by a number of promising insights and novel design concepts relevant to the NASA/KSC/CELSS program. Overall, this program is considered to have been clearly successful, and well worth the resources invested in it.

APPENDIX A

EGM 4000

Engineering Design I

**Preliminary Design of a Biomass Management System
for Use in a Closed-Loop Life Support System**

Prepared for

**National Aeronautics and Space Administration
Kennedy Space Center, Florida
and
Universities Space Research Association**

December 1990

Prepared By

**EGM 4000 Engineering Design
Department of Aerospace Engineering,
Mechanics and Engineering Science**

EGM 4000

ENGINEERING DESIGN I

Preliminary Design of a Biomass Management System
for Use in a Closed-Loop Life Support System

Prepared for

National Aeronautics and Space Administration
Kennedy Space Center, Florida

and

Universities Space Research Association

December 1990

Prepared By

EGM 4000 Engineering Design
Department of Aerospace Engineering,
Mechanics and Engineering Science

University of Florida
Gainesville, Florida 32611
(904) 392-0961

Instructors

Dr. Gale E. Nevill, Jr. and Dr. Yechiel Crispin

Editor

Michael A. Gedwill

Assistant Editors

Robert L. Clement
Pablo C. Gersberg
Michael I. Hessel Jr.
Bernadette Konopka
George E. Richert, Jr.
Robert N. Tullo

TABLE OF CONTENTS

Acknowledgements	i
Executive Summary	ii
Class Roster	iii
Introduction	1
Planting and Harvesting	4
Aeroponics and the Plant Growth Unit	5
Mechanical Harvesting	7
Automated Harvesting	8
Human Harvesting	14
Harvesting Matrix Analysis	16
Plant Propagation	22
Initiating Growth in the PGU	24
Harvesting Schedule	24
Proposed Subsystem	25
Food Management	26
Food	28
Processing	29
Preparation	32
Storage/Preservation	34
Menu Ideas	36
Proposed Subsystem	37
Resource Recovery	39
Waste	40
Waste Processing Methods	41
Edible Fungus	48
Aquaculture	51
Proposed Subsystem	56
Refurbishing	59
Tray (Flat Plate)	60
Tube	61
Aeroponics	61
Possible Refurbishment Techniques	62
Microorganism Refurbishing	67
Proposed Subsystem	69

Transport	71
Guidelines for Transport System Designs	74
Liquid Mass Transport System	74
Gaseous Mass Transport System	75
Solid Mass Transport System	76
Solid/Liquid Mixture (Slurry)	78
Proposed Subsystem	80
Integrated Biomass Management System	81
Planting and Harvesting	82
Refurbishment	82
Resource Recovery	83
Food Management	84
References	85

ACKNOWLEDGEMENTS

The members of the EGM 4000 Design class appreciate:

The cooperation of the National Aeronautic and Space Administration and the Bionetics Corporation, particularly

Dr. William Knott

Dr. John Sager

Mr. Dennis Chamberland

Dr. Ray Wheeler

Dr. Richard Strayer

Mr. Thomas Dreschel

the contributions of the following faculty of the University of Florida,

Dr. J.R. Ambrose

Dr. R. Harrell

Dr. P. Jones

Dr. Ulrich Kurzweg

Dr. A.J. Long

Dr. Renwei Mei

Dr. Lawrence Shaw

Dr. E.D. Whitney

and the guidance of Dr. Gale E. Nevill, Jr., Dr. Yechiel Crispin, Barry Finger and Pedro Rodriguez, instructors and teaching assistants for EGM 4000.

EXECUTIVE SUMMARY

The goal of the Fall 1990 EGM Design Class was to design and integrate a Biomass Management System (BMS). Five groups--Planting and Harvesting, Food Management, Resource Recovery, Refurbishing, and Transport--were then established to meet this objective. Each group investigated possible solutions to problems in each subsystem. Final recommendations and conclusions for an integrated BMS follow in this report leading to a discussion of the integrated system.

1990 EGM 4000 DESIGN CLASS

Richard Boddington

Robert Borys

Andrew H. Bream

Isabel Chong

Robert L. Clement

Michael A. Gedwill

Pablo C. Gersberg

Michael I. Hessel, Jr.

Bernadette Konopka

Todd Long

Sofia Lopez

James Miller

George E. Richert, Jr.

Robert N. Tullo

INTRODUCTION

The Controlled Ecological Life Support System, also known as CELSS, is an on-going research and development program conducted by NASA at KSC. The EGM 4000 design class deals with a CLLSS, or Closed-Loop Life Support System. Our CLLSS is loosely based on KSC's CELSS. The following report details a preliminary design of a system for biomass management on a long term space mission.

Biomass Management System

The overall goals of our Biomass Management System--plant growth, food production, and waste regeneration--mandated a division into five task oriented groups. These five groups are Planting and Harvesting, Food Management, Resource Recovery, Refurbishing, and Transport. A display of their interactions is shown in Figure 1.

Constraints. During the design of the various subsystems, constraints were self-imposed. A crew of four was specified, six crops--wheat, soybeans, potatoes, lettuce, peanuts, and carrots--were selected, systems were to be capable of operating in microgravity conditions, and soil was not allowed as a growth medium.

Planting and Harvesting. Planting and Harvesting deals with the growth, maintenance, and harvesting of the food crops chosen for the BMS.

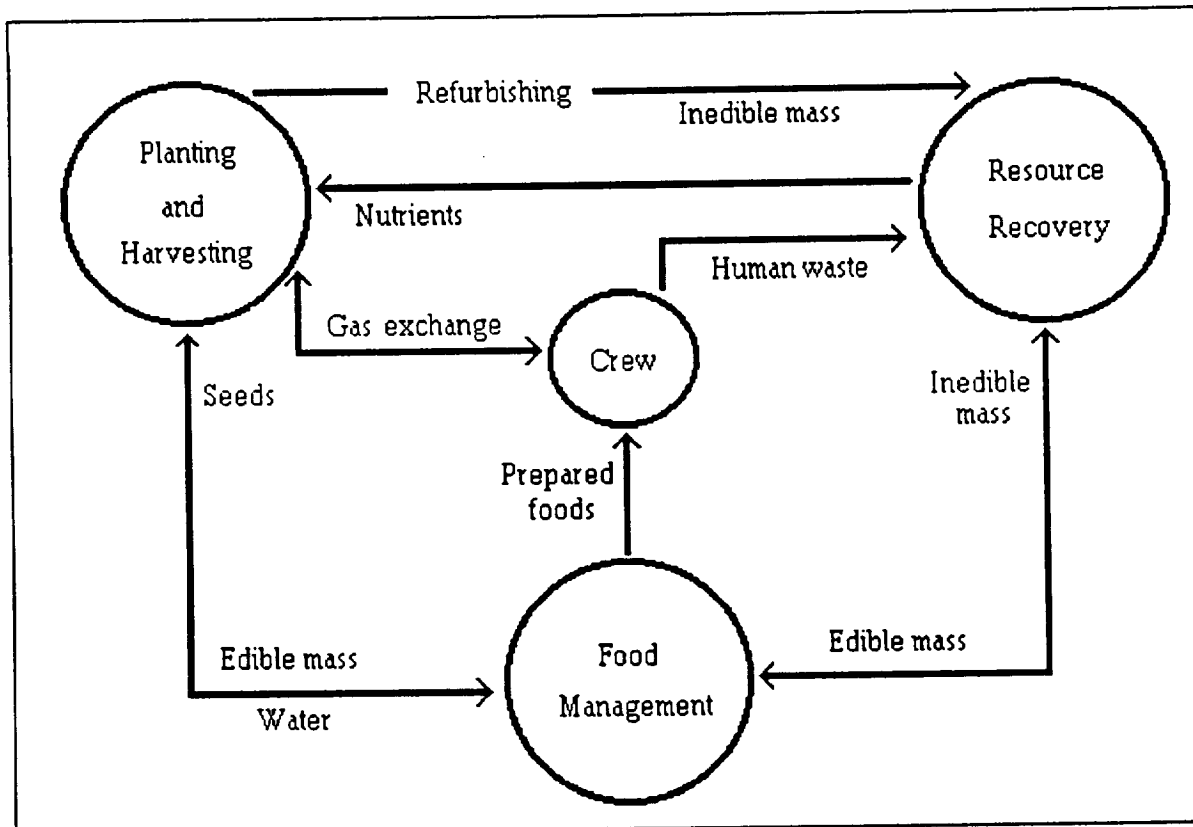

Figure 1. Biomass management flow chart.

Refurbishing. Refurbishing involves the removal of non-edible biomass such as roots and stems from the growth chamber, as well as the preparation of the chamber for the next growth cycle.

Food Management. Food Management deals with the production of edible products from food sources.

Resource Recovery. Resource Recovery involves the recycling of all waste materials.

Transport. Transport deals with the movement of substances within the Biomass Management System.

Each subsystem of the Biomass Management System (BMS) will now be discussed in detail, followed by conclusions and recommendations.

PLANTING AND HARVESTING

Prepared By:

Richard Boddington
Michael A. Gedwill
James Miller
George E. Richert, Jr.
Robert N. Tullo

PLANTING AND HARVESTING

A system for planting, maintaining, and harvesting crops is necessary for a long-term space mission. Aeroponics is a possible method of growing higher order plants in space, while harvesting could be accomplished by either mechanical, automated, or human systems. The following is a discussion of these topics, along with methods for determining the most reasonable method for harvesting specific crops.

Aeroponics and the Plant Growth Unit

A decision was made to recommend aeroponics instead of porous tubes or trays for the CLLSS design. Reasons for this included plant health, the space provided for tubers and root crops, and the ease of refurbishing, which will be discussed later. A design for a plant growth unit was then conceived using aeroponics as a nutrient delivery system.

Aeroponics. Aeroponics involves the distributing of essential elements and water via a mist or spray. The roots of the plant are suspended in air and in close proximity to the nutrient nozzles (Stoner, 1983).

Plant Health. In studies comparing plants grown in soil, hydroponically, and aeroponically, the aeroponically grown plants were found to be at least as healthy as the others. Aeroponically grown plants were actually found to be healthier in some cases (Stoner, 1983).

Tubers and Root Crops. Due to the free-hanging roots, room is provided for the tubers and root crops such as carrots and potatoes. The porous tube, however, has no such provision.

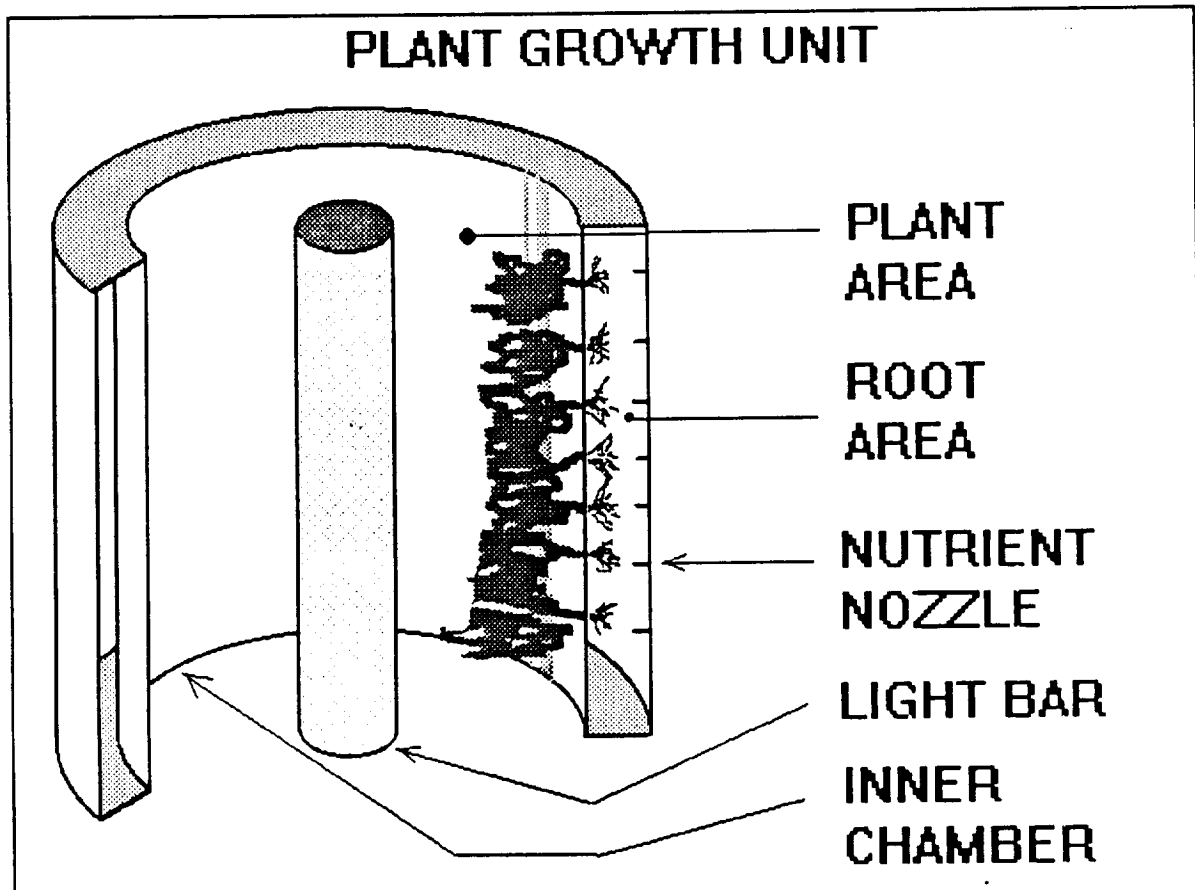

Figure 2. Illustration of PGU for use in CLSS.

Plant Growth Unit. An illustration of a possible plant growth unit, or PGU, is shown in Figure 2. The cylindrical shape can provide radial acceleration by rotation for proper germination direction. The outer cylinder contains the nutrient spray nozzles while the light bank is located in the center of the inner cylinder.

Mechanical Harvesting

Most grain and seed crops are harvested with combines. Existing systems have shown the flexibility to be scaled down and therefore could conceivably be used in the PGU. The following is a discussion of possible microgravity combines.

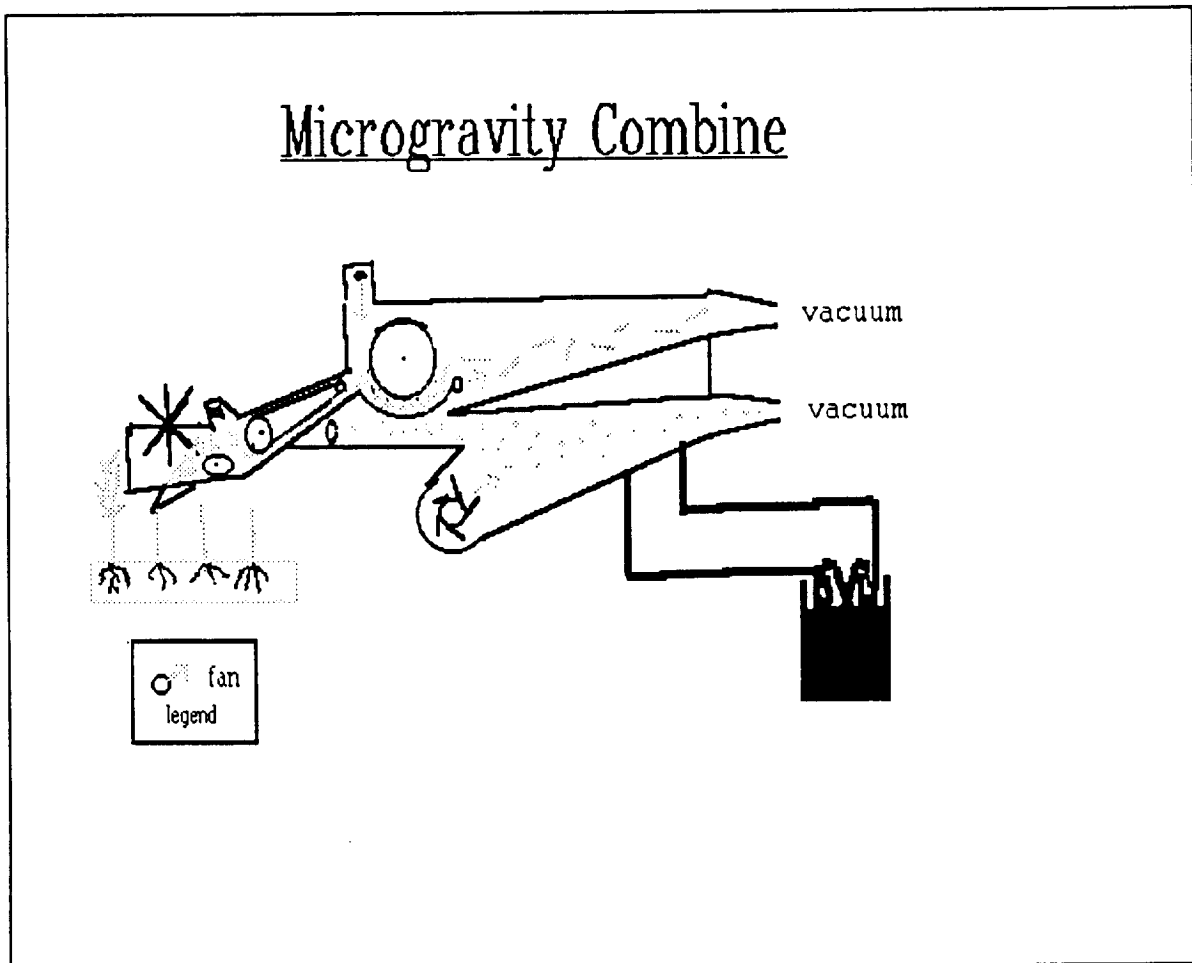

Figure 3. Possible microgravity combine for use in CLLSS.

Microgravity Combine. Conventional combines are safe, easy to operate and maintain, and

extremely reliable. A combine used 250 hours per year would have an expected life of approximately eight years (Kepner, 1978). The field combines currently in operation are approximately 98% efficient in cutting and separating the edible portion, however, in a controlled system the efficiency could approach 100% (Shaw, 1990). A microgravity combine would need certain modifications such as a containerization device, but this should not affect the performance. Figure 3 illustrates a conceptual design of a microgravity combine harvester. At an estimated weight of 200 pounds, the launch cost would be 1 million dollars.

Automated Harvesting

An automated harvesting system is defined as a system which can identify and harvest a specific structure on a plant with little or no human intervention. Although current harvesters such as the Florida Picker would need to be improved, many advantages can be projected for the use of an automated harvester in CLLSS. Also discussed in the following sections are recommendations for the incorporation of an automated harvester and a cost analysis.

Advantages. Much of the technology has been developed and only needs to be scaled to the CLLSS system. Another major advantage is that an automated system is better suited to picking more than one crop than a mechanical harvesting system. This advantage is possible because the automated system harvests by picking one vegetable at a time. It would

then make little difference to the harvester as to the type of vegetable it was picking. Automated systems which can be applied to CLLSS have also been developed in the citrus industry. Harvest times per fruit as low as one second have been achieved (Harrell, 1987). This rate makes robotic harvesting competitive with human harvesting in time and cost.

Improvements Needed. Before implementing the current technology into a CLLSS system, some improvements are needed. The first is to increase the reliability predicted by current technology. The current system needs too much maintenance time compared to harvesting time to be useful in CLLSS. Tables 1 and 2 show an estimation of the reliability and life expectancy of various components of the picking arm. For lettuce, carrots, soybeans, and potatoes, the pick cycles needed for a three year mission are about half that of the least reliable component. Although the Florida Picker is still in the research and development stage, it has been projected that the picker will be extremely reliable and human independent within the next ten years (Harrell, 1990).

Table 1. Determination of pick cycle for a three year mission based on the amount of crop needed.

PLANT	WEIGHT OF FRUIT	GRAMS CONSUMED PER PERSON * DAY	PICK CYCLES FOR MISSION
Potato	150 g	568.8	16,609
Lettuce	130 g	187.9	6330
Soybean	400 g/tray	417.6	1,097,453
Wheat	300 g/tray	160.7	-
Carrots	56 g	35.1	2746
Peanuts	5 g	141.8	124,173
TOTAL PICKS			1,247,311

The number of pick cycles was determined for a crew of four for a three year mission.
 Pick cycles = grams consumed * 4 people * 365 days * 3 years. / weight of fruit.
 Wheat may be harvested with a combine type attachment and therefore was not given a pick cycle.

Table 2. Reliability of components for the picking arm.

COMPONENT	ESTIMATED LIFE (MPC)*	ESTIMATED (YRS)
Rack and pinion for slider	2.5	6
Hydraulic motor for slider	2.4	6
Servo valve for slider	10	24
Hooke-joint actuators (2)	10	24
Hooke-joint servo valves (2)	10	24
Picking mechanism motor	2.4	6
Strobe lamp	10	24
Color camera and lens	10	24
Range Sensor	10	24
Cable and hose set	5	12
Steel bearings and bushings	2.5	6
Position-velocity sensor set	2.5	6

The estimated life expectancies (in years) were calculated from the amount of pick cycles needed for a crew of four using six crops for three years.

Estimated reliability (years) = $3 * (\text{pick cycles (mpc)} / 1,250,000)$

* million pick cycles

Florida Picker. A current automated picking system can be found at the University of Florida. The component of the Florida system important to the CLLSS project is the robotic picking/sensing arm shown in Figure 4 on page 14. In its few years of development, much has been accomplished and many problems have been overcome. The harvester is currently operational with a pick efficiency of 85% and a pick time as low as one second (Harrell, 1987). The arms are operated in the following manner:

The arms are hydraulically actuated and have three degrees of freedom. The arms pivot in a Hooke-Joint base about intersecting perpendicular axis. A prismatic link mounted in the Hooke-Joint provides motion in and out of the canopy. Arm actuation is accomplished with two rotary actuators and a hydraulic motor. A rack and pinion drive is used to obtain linear motion from the hydraulic motor. High performance servo valves controlling actuator flow, are used to achieve the dynamic performance required to pick moving fruit as well as stationary fruit (Harrell, 1987).

The sensing and picking mechanism is at the end of the arm, consisting of a rotating lip mechanism and a color video camera. The camera enables the picking arm to rapidly distinguish between various colors and shapes in order to identify a fruit from its surroundings. In addition, there are ultrasonic range sensors and a stroboscopic lamp to give the arm a sense of direction. All of these sensors are incorporated into fruit identification and location software. Once the fruit is detected by the vision system, the centroid of the fruit is determined and aligned with the center of the camera (Pool, 1989). Once the arm nears the fruit, the ultrasonic sensor aids in detecting the position and location while guiding the rotating lip picking mechanism.

Recommendations. There are two recommendations for the application of an automated system to CLLSS. The first is to have interchangeable picking heads in order to adjust for the size and needs of different crops. The current system can handle crops in a diameter range of 5 to 10 cm. This figure can be easily adjusted and many vegetables such as lettuce, soybeans, potatoes, radishes, and carrots could be handled with one head. It is projected that only wheat would need a specialized head, such as a small combine. The second recommendation would be for the arm to be able to slide up and down a pole positioned in the middle of a PGU. The arm could then reach 360 degrees around the chamber as it moved from level to level. A transport system would be needed to move the robot from one chamber to the next, allowing one arm to service more than one PGU.

Cost Analysis. For a preliminary cost analysis, there are three main areas to be considered for the automated system:

Table 3.

Total cost per arm:	\$ 15,000
Cost of support equipment:	
Hydraulic power unit:	\$ 8,000
Electrical unit:	\$ 5,000
Harvester control computer:	\$ 15,000
Guidance and control computer:	\$ 5,000
Support Structure and tracks: (estimated up from grove units)	\$ 30,000
Fruit collection system:	<u>\$ 4,000</u>
Total cost of support :	\$ 67,000 (Harrell, 1987)
Total launch cost :	\$ 2,200,000
(Mass Estimate of 440 lbs. @ \$5,000 per pound)	

Total cost of automated system:

$$\$45,000 (3 \text{ arms}) + \$67,000 + \$2,200,000 = \$2,312,00$$

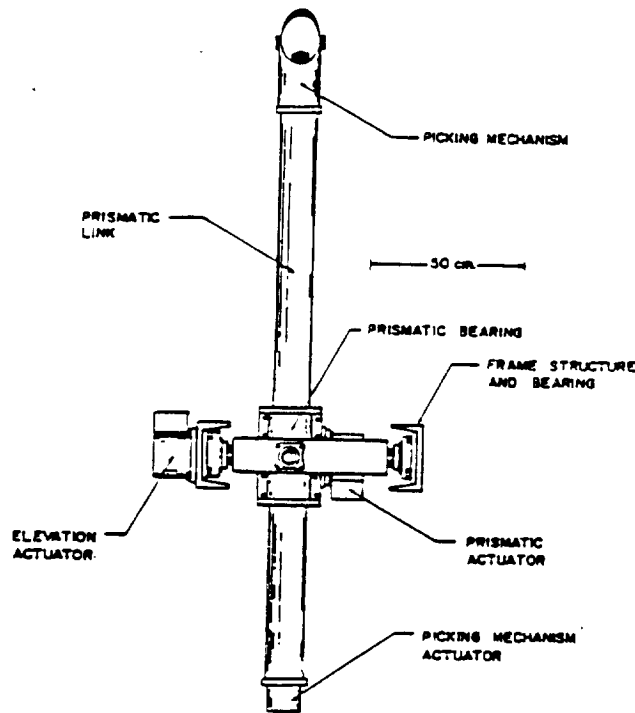

Figure 4. Robotic picking arm.

Human Harvesting

Human harvesting involves either the rotation of harvesting duties among the crew or the addition of an extra crew member for the sole purpose of harvesting. An added crew member would represent the most difficult scenario, therefore the following is an analysis of this system.

Advantages. A human is an intelligent being. He or she can be trained to harvest efficiently. Barring sickness or injury, they would be extremely reliable. Most significantly, humans are flexible and can handle most unexpected situations.

Disadvantages. Humans have physical and psychological limitations. For example, the astronaut may want to occasionally oversleep. Also, he or she will not be able to work for 24 hours at a time if necessary.

Costs. The addition of another crew member will require increased mass and volume, thereby increasing the overall cost. The space allocated for the human includes sleeping quarters, normal crew facilities, such as the dining and living areas, and the space needed to grow the food for the extra crew member. If the extra space is approximately 25 m³ (3 m X 4 m X 2.5 m) for quarters, 25 m³ for the rest of the ship facilities, and 40 m³ (40 m² X 1 m) for the PGU addition, the total additional space would be 90 m³. Since the data on construction costs is not readily available, they will be neglected in the following cost analysis.

- 1) Training costs for a mission specialist position: \$750,000 (Sager 1990)
- 2) Increased launch cost due to weight of the astronaut (180 lbs avg):
\$900,000 (Sager 1990)
- 3) Increased launch cost due to weight of the additional plants in the PGU
(Table 4): \$5,524,000
- 4) Astronaut Pay at \$50,000 per year excluding pay during training period:
\$250,000 for a five year mission (Sager 1990)

Total cost = \$7,424,000

Table 4.
Launch costs for additional plants for one person.

Plant	Harvesting Days (HD)	Harvesting Weight (HW)	Cost
soybean	80	949	\$417,560
potato	90	782	\$387,090
peanut	120	5952	\$3,928,320
carrots	80	500	\$220,000
wheat	80	1207	\$531,080
lettuce	28	257	\$39,578
TOTAL		\$5,523,628	

Cost = $1/2 * HD * HW * 2.2 \text{ lb/ kg} * 1 \text{ kg} / 1000 \text{ g} * \$5000 / \text{lb}$. The weight of the plant at harvesting is the harvesting weight. The weight at seedling is zero. For a first approximation, assuming a linear growth pattern of the plants such that $HW * \text{age} / HD$ is the weight of any plant, the weight of any plant at any growth stage can be computed. By integrating with respect to age-- $1/2 * HW * \text{age}^2 / HD$ over the entire growth period--the equation $1/2 * HW * HD$ yields the mass present in the chamber for a particular crop.

Harvesting Matrix Analysis

The selection of the best possible harvesting method may be facilitated by use of a harvesting matrix analysis. This involves a comparison of the possible methods, weighing criteria appropriately, to find the most appealing method for each specific crop.

Criteria. The important factors in selecting a system are the criteria of the problem, which include anything that affects the choice of a particular system.

Weights. Each of the criteria are given weights so that important criteria will affect the total outcome more strongly than less significant ones. A weight of 1 means not very important, 2 means relatively important, and 3 means extremely important.

Rankings. After the criteria and their weights are chosen, rankings that reflect how well the particular system satisfies the criteria are assigned. A rank of 1 means poor, 2 means good, 3 means excellent.

Analysis. Multiply the weight of a criteria by its corresponding rank. This is done for each of the criteria, and the results of the products are summed up. This procedure is done with each system, and the column with the highest total represents the best overall choice. It is possible that there will not be a single system that is capable of harvesting all of the crops in the most efficient manner. As a result, a group of systems may be necessary to accomplish the task. For example, a human might harvest the potatoes, radishes, and lettuce, while a mechanical system might be best for the rest of the crops.

Example. The following is an example of how a harvesting matrix would be used in the selection of a soybean harvester.

Step 1 : Declare the criteria and the weights for each.

Mass : Weight = 3

This is extremely important because it affects launch costs (fuel amounts, size of launch vehicle, etc).

Space : Weight = 3

This is extremely important because it affects launch costs and construction costs. In general, the cost is proportional with the size.

Harvesting Efficiency : Weight = 3

This is the amount of edible biomass obtained per total amount of edible biomass available. Since there is a limited amount of space available in the PGU, it is extremely important to maximize the amount of food obtained from a given volume. The more efficient the harvester, the less room needed to house the plants.

Separating Efficiency : Weight = 2

The efficiency with which the harvester separates the edible from the inedible biomass. This is relatively important because less additional support equipment will be needed and less post processing will required to do the separation.

Mechanical Efficiency : Weight = 1

Mechanical efficiency is related to the power required to harvest the PGU. Since there is an abundance of power, the energy loss due to the system is not a major concern.

Reliability of Harvester : Weight = 3

Reliability is defined to be how often the system will be operational. It is extremely important that the harvester be reliable because of the stringent harvesting schedule imposed on the system.

Maintenance Time : Weight = 2

This is defined to be normal preventative maintenance to keep the system operational. It is relatively important because high preventative maintenance time will require too much human time and/or a very complicated automated maintenance system to do the work.

Cost : Weight = 2

This includes the cost of the system, research costs, and the launch costs. Since it is more important to have efficient and reliable systems, cost is only relatively important.

Support Equipment : Weight = 3

This is the extra equipment such as computers, controls, and sensors necessary

to complete the harvesting. This is very important, since the amount of the support must be kept to a minimum in order to decrease the mass and volume added to the CLLSS module.

Time of Harvesting : Weight = 3

The time required to harvest the crops in the PGU is extremely important since there is a rigid harvesting schedule. Also, since there will not be much storage space available, it is important to keep harvest times low in order to keep the additional stock to a minimum.

Complexity of the Harvester : Weight = 2

The complexity of the harvester is defined to be the amount of technology and equipment needed to make the harvester work.

Compatibility of the Harvester : Weight = 2

This is a measure of how many crops that a particular system can handle. This is relatively important, because it will decrease the mass and volume requirements of the PGU.

Step 2 : Define the plant in question and assign rankings to each system.

Table 5.

Matrix Analysis of Soybeans				
	Human	Mechanical	Automated	Weight
Mass	2	2	1	3
Space	1	2	2	3
Efficiencies:				
A) Harvesting	3	3	2	3
B) Separating	3	3	3	2
C) Mechanical	3	2	2	1
Reliability	2	3	2	3
Maintenance Time	3	2	2	2
Cost	2	3	2	2
Support Equipment	1	2	2	3
Harvesting Time	1	3	2	3
Complexity of Harvester	3	2	2	3
Compatibility of Harvester	3	2	3	2
Total Rank	64	73	61	
BEST SYSTEM	no	YES	no	

Step 3: Multiply the ranks in the columns by the weights for each of the criteria. Total the products for each column to find the best overall system. For this example, a mechanical system would be best. A finer scale for the weights and rankings should help to more accurately differentiate between the harvesting systems.

Plant Propagation

During the space mission, many generations of plants will be grown. The next few sections will examine some of the techniques for the propagation of plants.

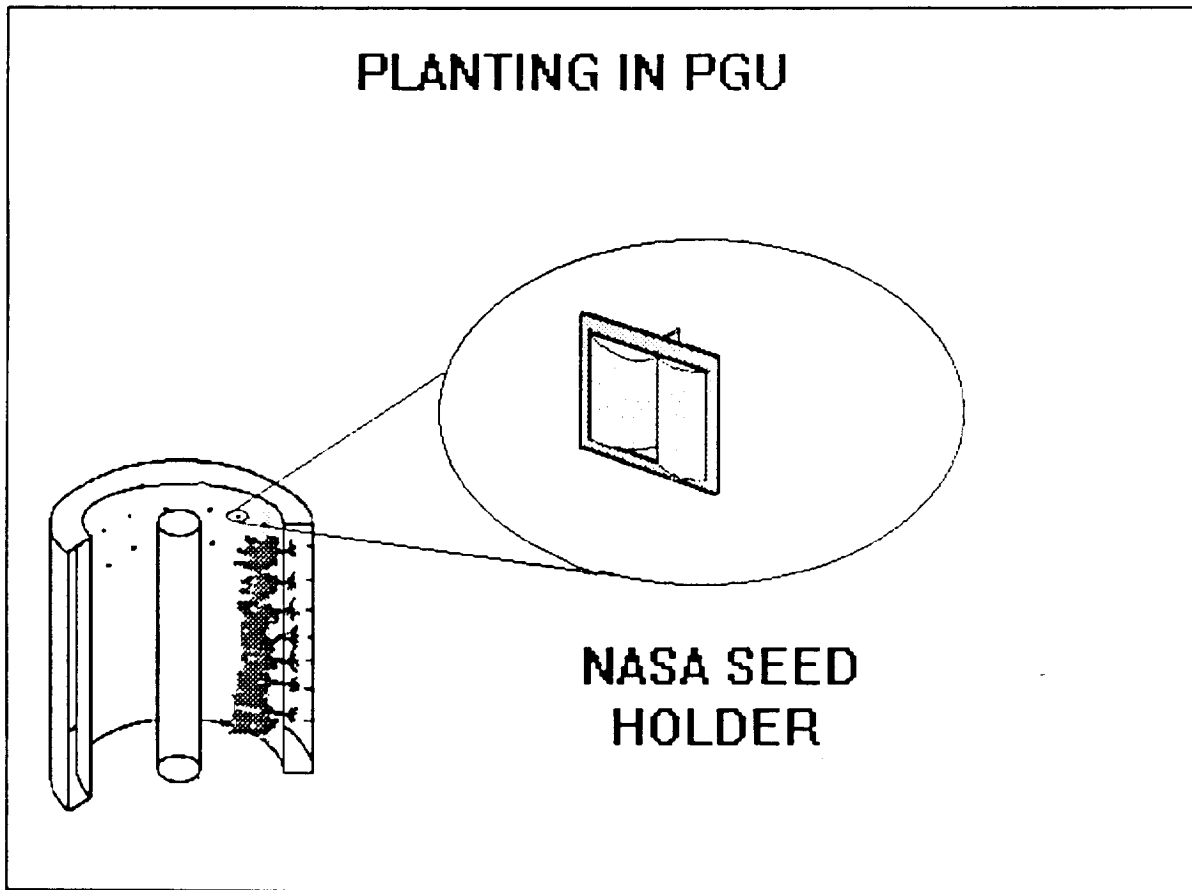

Figure 5. NASA seed holder placement in PGU.

Seeds. The seed holders developed by NASA will be utilized. The seeds may be "planted" between the plastic flaps by a mechanical system or by hand. A mechanical system would be better since the task to be performed is not difficult and because of the better speed.

One of the possibilities is the "minnow bucket" method developed in the 1988 EGM 4001 course. After the seeds have been planted, the PGU will be spun in order to ensure proper germination direction. Figure 5 is an illustration of a seed holder placed inside a PGU.

Tissue Culturing. The alternative for seed planting would be tissue culturing, which produces a clone of the original plant. This method offers certain advantages over seed planting. Since tissue culturing is a form of asexual reproduction, the problem of pollination can be eliminated. However, culturing is much more labor intensive. Proper growth is usually aided by hormone stimulation of the transplant, therefore the first stages of growth must be carefully monitored until the root tip and shoot differentiate. In addition, it is not currently possible to tissue culture all of the plants selected for CLLSS.

Tuberization. Plants which are tubers can be propagated by cutting the edible portion, or tuber, such that each piece has a node containing one or more buds. The bud contains all of the genetic information in order to make a new plant, and will proceed to differentiate normally (Jones, 1990). Nevertheless, this method is specific only to certain kinds of plants and can not be performed on all of the plants selected for CLLSS.

Initiating Growth in the PGU

The best way to start the PGU must be determined. The first possibility would be to start the CLLSS module while the ship is on the ground. After the plants are in the proper growing schedule (approximately 90 days later) the ship would be launched and the astronauts would have plants ready to be harvested on the first day of the mission. The alternative is to bring seeds along with all of the raw materials and to start the module during the mission. During the time that the PGU establishes the proper growing cycle, the astronauts would eat traditional space food. Since the raw materials are mainly compressed gases, this method reduces the volume requirement on the payload, thus making the logistics of the launch easier. This would not reduce mass of the system however, since the carbon required for the plants must be present. In fact, it would probably increase the mass, since the pressurized containers, their support equipment, and the astronauts' food must be included.

Harvesting Schedule

Finally, the harvesting schedule must be considered. Certain crops such as lettuce and carrots must be harvested on a continuous basis since they are perishable. Other crops such as wheat or soybeans can be harvested in batches. The harvesting schedule must be compatible with the refurbishing schedule. For example, if the chamber has plants in

varying stages of growth, it will never be empty. Therefore, the refurbishing must be done on an individual basis, without disturbing the rest of the plant population. A solution could be to harvest on a semi-continuous basis with smaller chambers housing the plants. All of the plants in a particular chamber would be at the same growth stage, and the chamber could be cleaned when the crop is harvested. For crops that are able to be grown and stored for long periods of time, batch planting would be better. This is because of the wasted space and support required by many little chambers compared with one big chamber. This has implications in the volume requirement needed for storage, since a 90 day supply would be necessary for wheat, instead of possibly a week's supply. More importantly, this will affect the amount of carbon and other elements that will be locked up in the system at any given time (Wheeler, 1990). By storing food, the carbon is taken out of the loop until the food is finally consumed. As a result, this will increase the initial amount of raw materials that make up a CLLSS module, and ultimately the cost of the mission.

Proposed Subsystem

A cylindrical PGU will be used in order to generate an artificial gravity by rotation. The seeds will be planted in NASA seed holders by the minnow bucket process designed by a previous class. For the nutritional needs of the crops, aeroponics will be used to deliver the nutrients to the plant roots. Wheat and soybeans will be harvested with a microgravity combine. Potatoes, carrots, peanuts and lettuce will be harvested with a sensor based, automated harvester. Some hand harvesting will be needed.

FOOD MANAGEMENT

Prepared By:

Michael I. Hessel Jr.
Isabel Chong
Robert Borys

FOOD MANAGEMENT

Food management is devoted to converting raw products into food ready for an astronaut to consume. An understanding of the techniques implemented in the food processing industry enabled us to structure our system as shown in Figure 6. Food derived from three possible sources is put into the processing division. Then, the processed food can be prepared in the preparation division and either served or stored. A listing of menu items which can be prepared using techniques outlined in this report has also been provided.

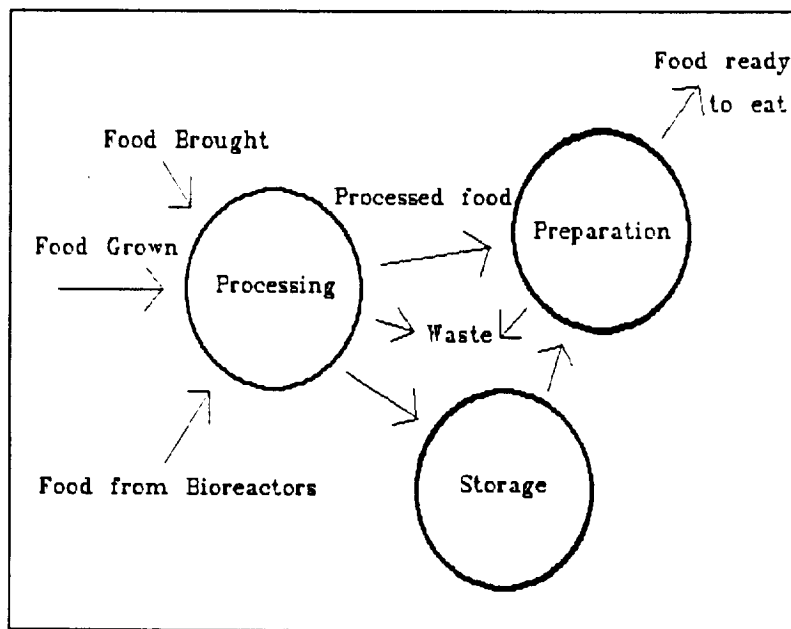

Figure 6. Food management flow chart.

Food

Three sources from which an astronaut crew can obtain its daily nutrition during a long term space mission have been identified. These are food grown within the biomass production chamber, supplements brought from Earth, and foods produced from the bioreactors of the CLLSS resource recovery phase.

Food Grown. The choice of crops to be grown within the growth module--wheat, soybeans, potatoes, peanuts, lettuce, and radishes--was initially provided by a representative of the NASA CELSS program. All were found valuable in contributing to human nutritional needs. From these crops, a variety of palatable menus could be prepared via an appropriate sequence of processing. However, the decision was made to replace radishes with carrots due to the relatively low nutritional value and extremely low preparation versatility of radishes.

Food Brought. Not all of the foodstuffs needed to operate a space galley can be produced by the CLLSS module. Certain low bulk items which are needed in small quantities--salt, pepper, garlic powder, Italian seasoning, NutraSweet®, onion pepper, and various spices--can be brought from Earth. A small supply of chocolate and vanilla extracts can facilitate the production of a variety of desserts, while small supplies of beef, chicken, and pork base can aid in the processing of simulated meats. Miscellaneous items such as baking soda, lemon juice, and tomato substitute can also expand menu options.

Food From Resource Recovery. Through interaction with the resource recovery group, it was learned that certain foods can be obtained from the recycling and chemical conversion of the inedible biomass. Certain biochemical reactors produce fructose and acetic acid, while edible fungus can be obtained by adding spores to the bioreactor sludge. Small tanks of fish can also be maintained from the inedible biomass left over from harvest.

Processing

We have defined food processing as making products from the harvested crops. It can be as simple as washing and chopping lettuce for salads, or as complex as making meat analogs from soy beans. Several types of food processors such as millers, choppers/shredders, cleaners, and extruders show promise for a long term space mission. The following is a discussion of these food processing units.

Wet Cleaner. Crops can be cleaned by either wet or dry methods. Wet cleaning is more effective than dry cleaning, and is less damaging to the crops. Potatoes, for instance, can be spray or brush washed (Talbert, 1987). Other types are drum washing and floatation tank washing. Dirty water is produced, however, which requires a method for recycling.

Dry Cleaner. Dry cleaning does not use a liquid medium, and can reduce microbial and chemical deterioration of food. The equipment needed is also smaller, cheaper, and less complex. Air classifiers, magnetic separators, and screening separators are examples of dry

cleaners, as demonstrated by a grain and chaff separator used for wheat, shown in Figure 7 (Fellows, 1988).

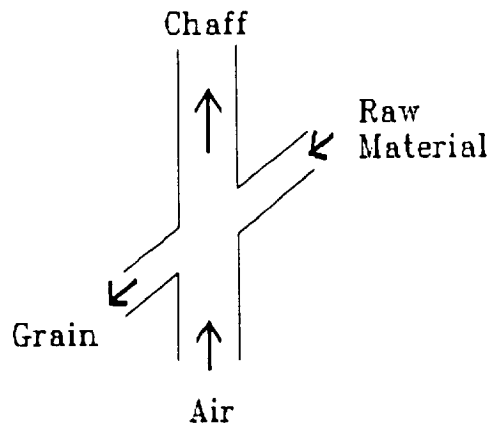

Figure 7. Air classifier used for wheat.

Wheat is fed through the small tube. As it passes through the junction, the chaff is blown away. As can be seen, this technique uses density differences for separation. Dry cleaning, however, can damage fragile crops. Dust leakage is also a major problem.

Miller. Size reduction includes processes such as milling, chopping, and shredding. A multi-crop machine with adjustable fixtures is preferable to several specialized machines, therefore machines should be designed to function with many different crops. Flour is an important product for the making of bread and pasta. Thus, a miller to grind the wheat and soy beans into flour is needed. A roller mill is a simple and available miller (Fellows, 1988). It consists of a feed barrel and a series of counter-rotating rollers shown in Figure 8. Since different rollers can be used for different crops, this miller would be very useful for a long-

term space mission. Microgravity applications also seem possible with some modifications. The miller could be cleaned by running pressurized water through the mill. With the proper inlet and outlet configurations the water can be contained.

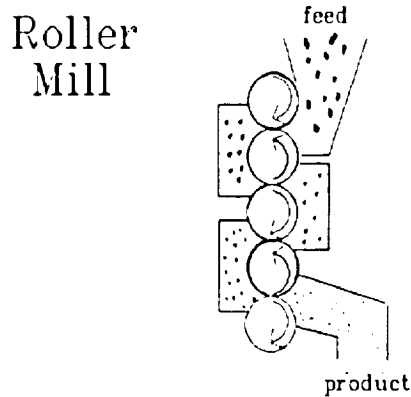

Figure 8. Roller mill.

Chopper/Shredder. Food processing also requires a method for chopping and shredding the crops. A chopper or shredder is needed to cut potatoes, lettuce, carrots, and peanuts. A series of guillotines, knives, or a machine similar to a Cuisinart® machine can be used. Interchangeable blades could enable the appliance to accommodate different products. The unit can be taken apart and wiped clean.

Extruder. Mixing and blending of ingredients is needed for processing food. For example, flour, milk, eggs, salt, and baking powder have to be blended in order to make bread. A machine that may make food processing simpler is an extruder. Extruders combine

operations such as mixing, cooling, kneading, shaping, and forming (Hall, 1986). Due to their versatility, a wide variety of products such as cereals, breads, pasta, and meat products can be obtained. Different shapes, textures, colors, and flavors are available by changing the added ingredients and operating conditions of the extruder. Another important quality is that little effluent is produced. The foods produced also have long shelf lives due to their low water content. This unit will be cleaned via pressurized water such as in the cleaning of the roller mill.

Preparation

We define preparation as taking the processed food and making it ready to eat, such as making bread from flour. Several units can be employed to accomplish this task. The following is a discussion of the appliances and methods that we feel are necessary for food preparation in space.

Oven. The oven taken on an extended mission should be able to accommodate any foods that require baking, such as breads, cookies, casseroles, and many other menu items. To fill all these needs, the oven should be a forced convection oven, automatically circulating the air and not depending on the Earth's gravity as do normal convection ovens (Smith, 1985). The oven should also use electricity to provide the heat for safety reasons. A gas powered oven would be lighter, but would run into problems of ventilation and of having to carry the gas. This unit will be wiped clean.

Oil and Water Immersion. Oil immersion is better known as frying, and water immersion is also called boiling (Glaser, 1985). These techniques are used extensively on earth, and could be adapted for space by overcoming a few problems. One problem that can be seen is how to mix and separate the food from the hot liquid cooking medium. Another problem would arise once the food is brought out of the fluid. The food would need to be well-cleaned of the medium in order to keep hot particles of liquid from detaching and floating about the environment. Again, the source of heat should be electricity for safety reasons.

Pan Fryer. Some of the menu items will require direct heat transfer from a solid object. On Earth, we are able to use a griddle or pan on the top of our range. In space, this technique will be difficult due to microgravity. This method of cooking may be the most challenging from an engineering standpoint, due to the restraining problems with liquid products. This unit will be wiped clean.

Broiler. A broiler is a heat radiator used to cook solid foods at high temperatures. This appliance may be incorporated into the oven, with electric elements serving as the heating device. The difficulty in this procedure would be restraining the food while not affecting the heat transfer.

Microwave. The microwave will play a small part in a space kitchen. This cooking unit primarily reheats food previously prepared. The microwave could be incorporated into the oven, giving the user the option of applying heat and microwave radiation simultaneously.

Storage/Preservation

Food preservation involves the use of science and engineering principles for the practical control of food deterioration. Various deteriorative factors must be considered, most importantly microbial organisms, but also heat, cold, light, oxygen, moisture, dryness, time, and the properties of the foods themselves (Potter, 1974). In general, a multiple of preservation operations are needed to combat the unique spoilage factors of a specific food. This can be accomplished by procedures such as heating, cooling, drying, smoking, chemical treatment, and irradiation. However, because cooling and drying have the additional advantage of decreasing the rates of nonenzymatic chemical reactions, the Food Management group has decided to focus on freezing, refrigeration, and drying/dehydration.

Freezing. One type of cold storage is freezing. For those foods that can withstand it, the optimum freezing temperature is less than or equal to 0°F. Bacteria flourish at a range of 60°F to 100°F and their growth becomes negligible at freezing. For maintaining food quality, fast freezing is needed. If freezing is slow, food damage can occur due to formation of large ice crystals and prolonged time for food constituents to be in contact with solutes that become concentrated as freezing progresses. Rapid freezing eliminates these problems and helps to retain the natural texture of the food. Three common types of freezing are:

1. Air freezing, using still or high velocity air.
2. Indirect contact freezing, using chilling plates or tubular heat exchangers.
3. Immersion freezing, using direct contact with a refrigerant such as freon or liquid nitrogen.

Using such methods, it is possible to obtain a storage life for vegetables from 6 to 12 months at a temperature of 0°F to -10°F.

Refrigeration. The other type of cold storage, refrigeration, is better for shorter term storage of foods. Nonfreezing cold temperatures are used to preserve foods in their natural state for the longest possible time. While some foods are best kept close to 32°F (beef, milk, lettuce), other foods become damaged at temperatures less than 55°F (sweet potatoes, tomatoes). Refrigeration temperatures should be tailored to the commodity for optimum storage life. Food products in storage should be stacked in a manner that allows adequate air circulation to maintain uniform temperature throughout the refrigeration compartment (Cook, 1974). This is especially true because non-frozen foods continue to respire and generate heat. Storage by refrigeration can be supplemented by modifying the atmosphere with chemical treatment and by controlling the oxygen-carbon dioxide levels. Some cooling methods include:

1. Air cooling, using fans or jets to maintain cool air circulation within the compartment.
2. Hydro-cooling, by spraying the product or immersing it in ice water.
3. Vacuum cooling, where rapid evaporation of water is induced in the product. Moisture loss from within the food is not sufficient to cause damage.

Drying/Dehydration. Preservation by drying/dehydration involves the reversible process of removing water from food material so storage life is extended by preventing microbial growth and biochemical deterioration. Most dehydration jobs require a resulting moisture

content of 5% or less. The advantages of dehydrating food are storage at ambient temperature, considerable savings in storage space, and the ease of preparation. Some drying/dehydration methods include:

1. Solid food drying by the use of tunnel or conveyor type dryers. These methods allow for good control of humidity, temperature, and flow rates at different stages of the process.
2. Liquid food drying by use of spray drying or revolving heated drums. These methods allow for rapid drying due to high rates of heat transfer.
3. Freeze drying, where the product is frozen and directly placed in a vacuum. The water is expelled by sublimation with minimal damage to the food. This method is excellent for vegetables, due to maintenance of quality and ease of reconstitution.

Menu Ideas

The menu options will be divided into dairy foods, meat-like foods, and bread/pasta foods. An example will be given for each category, with each example listing the basic ingredients, and the processing and preparation involved.

Dairy foods. An example of dairy foods is soy milk. Soybeans are ground into flour and water is added. The mixture is then brought to a boil and strained. The liquid product is similar to cow milk not only in flavor but also in nutritional value (Snyder, 1987).

Meat-like foods. An example of a meat-like food is soy burger. Soy flour is mixed with water and sent through a centrifuge to isolate the soy protein. The protein isolate is then passed through a cooker-extruder, where it assumes a fibrous quality. Additional hydration

enhances the texture of the food, and in combination with a selection of meat bases, a number of meat analogs can be produced. The meat analogs can then be used in meatloaf, spaghetti, sausage, or tacos.

Bread/Pasta foods. An example of a bread/pasta food is pasta. The mixing of water and wheat flour will produce a pasta dough which can be passed through an extruder to obtain the desired pasta shape. A drying unit is needed to remove the moisture if long-term storage is desired.

Proposed Subsystem

The crew may benefit psychologically from interactions with the preparation phase of food management. Preparation units should look like units found on Earth in order to create an aesthetically pleasing environment. Other designing factors include particle restraint and ease of cleaning. Most of the technology required for a space kitchen exists in the food processing industry and could be adapted to microgravity conditions. Processing units we recommend include both wet and dry cleaners. An air classifier should be an excellent dry cleaner due to its adaptability to microgravity. A roller mill should be used for grinding grain products such as wheat, soybeans, and peanuts while a food processor should be used to chop and shred the food. Because of all the advantages an extruder offers, it should also be incorporated to the space kitchen. The essential preparation units are an oven/microwave/broiler, pan fryer, and fluid immersion cooker. Finally, storage techniques

such as dehydration, refrigeration, and freezing can be modified to keep perishable food fresh.

RESOURCE RECOVERY

Prepared By:

Andrew H. Bream
Robert L. Clement
Bernadette Konopka
Todd Long
Sofia Lopez

RESOURCE RECOVERY

On a 90 day mission, 4 crew members produce 12,000 - 13,000 pounds of refuse (University of Central Florida, 1988), or 48,000 pounds in one year. The shuttle, for example, is only capable of returning to Earth with 24,000 pounds of refuse. In addition, the cost of transporting payload can be as high as \$5000 per pound (University of Central Florida, 1988). Due to the cost and size of the payload, the only alternative is to process the waste and recycle as much as possible. The purpose of the resource recovery group is to design a system that is capable of recovering nutrients and recycling water and air from waste. The systems used can be biological, physicochemical, or a combination of both. The cultivation of edible fungus and the use of an aquaculture may also help to recycle waste.

Waste

Waste products include human excretion, atmospheric contaminants, and plant or food waste.

Human Waste. Human waste consists of urine and feces. The average person produces 0.07 pounds per day of feces and 0.23 pounds per day of urine (Life Sciences Research CLLSS Project, 1986). Once processed, nitrogen, urea, and water can be recovered and returned to the plant growth chamber.

Plant Waste. Food or plant waste consists of inedible biomass such as cellulose. After sending cellulose through the waste processing system, products such as glucose, water, minerals, and carbon dioxide can be recovered. The glucose can be used as a growth medium for protein producing bacteria or edible fungus. It can also be used as a caloric supplement for the crew.

Atmospheric Waste. Atmospheric waste consists of the byproducts of crew metabolism expelled during sneezing, perspiration, and respiration. In one day the average person produces 4 pounds of water through perspiration and respiration (Life Sciences Research CLLSS Project, 1986). It is important to remove contaminants from the atmosphere that are harmful to plant growth or the functioning of the equipment. Excess trace contaminants such as dust and water vapor must be extracted. Gases such as carbon dioxide and methane must also be removed from the crew compartment.

Waste Processing Methods

An effective method for recovering nutrients from human and plant waste is necessary. In order to keep human excrement out of the cellulose conversion reactor from which glucose is obtained, we have decided that human waste should initially be separated from plant waste. Therefore, a filtration step is avoided. Resource recovery can be accomplished through incineration, wet oxidation, super critical water oxidation, vapor compression distillation, thermoelectric integrated membrane evaporation, vapor-phase catalytic

ammonia, plasma gas reactors, leachate reactors, cellulose conversion reactors, or a combination of these methods.

Incineration. Dry incineration (INCIN) is designed to incinerate human feces, urine, and nonhuman wastes at 600° C (Slavin et al.,1985). The advantage of this method is the production of sterile products. However, the dirty effluent requires post treatment. The incineration process takes 6.5 hours and the cool-down process takes 17.5 hours, resulting in a total of 24 hours for a single processing cycle. This 24 hr cycle time is for processing 1230 grams per day of water with 475 grams of solids (ibid.). The large volume and weight requirements in addition to the high temperature and long processing time make this method unappealing.

Wet Oxidation. Wet oxidation (WETOX) is designed to process human feces, urine, and spacecraft wastes while recovering useful gases and water for recycling. The advantages include the ability to process solid and liquid waste. The solids produced are then reduced to a sterile non-degradable ash of very small volume. Once the solid is reduced to ash, the valuable carbon content cannot be further used within resource recycling. Ash production, therefore, should be kept to a minimum. Other disadvantages include the requirements of high temperature (550° F), high pressure (2200 psia.), and incomplete combustion and reduction of wastes (ibid.). Optimum reaction time is about 1.5 hours.

Supercritical Water Oxidation. Supercritical water oxidation (SCWO) involves the rapid oxidation of aqueous wastes containing solids. These wastes are processed above the critical temperature (705° F/376° C) and pressure (3208 psia/215 bar) of water. Advantages include the ability to process solids, clean effluent, and a short reaction time of 1 minute or less. This process oxidizes organic materials at efficiencies greater than 99.9% without the use of catalysts (ibid.). Disadvantages include a very high operating temperature (1240° F) and pressure (3674 psia) which result in high weight, volume, and heat rejection (ibid.). This system processes 65 pounds per day with continuous operation, and produces a reusable effluent. The effluent does not require further treatment and has a very short reaction time, however, high temperature and pressure is required.

Vapor Compression Distillation. Vapor compression distillation (VCD) is a phase change process designed to recover potable water from urine and wash water. Waste water is boiled off at sub-atmospheric pressure in a compressor/condenser. Advantages include low power consumption, high heat recovery, and high water recovery rate (96% by weight of the water in incoming waste). Disadvantages include the inability to process solids and failure to meet NASA's water standards. This system processes 35.6 pounds per day of liquid wastes with a 90% continuous cycle (ibid.). The much lower operating temperatures and pressures makes VCD a good process for waste water, but the water would require further treatment for human use.

Thermoelectric Integrated Membrane Evaporation System. TIMES is a phase change process designed to provide water recovery with minimum complexity. Other advantages include low power consumption, high heat recovery, and high water recovery rate. Disadvantages include inability to process solids and low water quality. The system recovers 4.5 pounds per hour of product water with 95% water recovery at solid concentrations of up to 3% by weight (ibid.). The system includes either continuous or batch operation at atmospheric temperatures (140° F) and pressures (1 atm). TIMES inability to process solids and the need for post-filtration makes its use in CLLSS limited.

Vapor Phase Catalytic Ammonia Removal. VPCAR is a hybrid process that recovers water and decomposes volatile substances to useful water vapor and gases. Advantages include high heat recovery and the quality of recovered water. Disadvantages include the inability to process suspended solids and high reactor temperatures (450° C) resulting in volume, power, and heat rejection requirements (ibid.). This system recovers 14 kilograms per day of waste water, and can be used to post-process water from VCD and TIMES or post-treat water vapor from INCIN and WETOX.

Press. The leaves of leafy green plants contain approximately 85% of the plant's protein. A press may be used to crush the leaves and extract a protein and vitamin rich liquid. The liquid protein removed from the press will undergo various treatments such as ultra centrifugation or preferential flocculation, in which the valuable proteins will be precipitated according to their isoelectric points (Chang, 1978). This protein can be used as a

supplement for a protein drink for the crew or as food for the fish in the aquaculture. The vitamins may be removed by other treatments and used where needed. A press will have to be designed with microgravity conditions in mind. The press should be relatively easy to design using radial acceleration as gravitational force simulation.

Plasma Gas Reactors. Plasma gas reactors offer a unique method of converting waste gas into usable material. The reactor uses electrical energy to break gas molecules apart. The gas molecules travel through a tube between two electrodes which make up the walls of the tube. An electrical current introduces enough energy to break the molecular bonds. The frequency-tuned capacitive discharge reactors (plasma reactors) work at approximately room temperature (21.0° C - 26.0° C). Three types of plasma reactors--the corona discharge, glow discharge and arc discharge reactors--were examined. Similar in design, these reactors run in different ranges of current densities. It is hoped that the plasma reactor will reduce waste gases such as methane to its atomic constituents, carbon and hydrogen. One disadvantage of the Plasma gas reactor is the production of ozone.

Leachate Reactor. A leachate reactor uses autotrophic bacteria to extract valuable minerals such as copper and zinc from inedible biomass. These minerals are recovered by a leaching or solubilization process. Once the bacteria reaches the mineral surface, insoluble sulfides are oxidized and released into solution. Thus, the bacteria uses oxidation as its source of energy. The bacteria can grow in both aerobic and anaerobic environments, however, oxygen (an aerobic environment) increases the speed of both the growth and leaching

processes. Hence, it is best to use the leachate reactor under aerobic conditions. A leachate reactor is currently being used in the recovery of minerals from low grade waste ores found in dumps and exhausted mines. Future use of leachate reactors with high grade waste ores is being considered (Wise, 1983). In CLLSS, a leachate reactor can be used to recover minerals from waste before it is processed in the core reactor. This reactor is capable of handling both solids and liquids, and requires approximately two hours to process 50 grams of dry weight per liter of solid crop residue and 1 liter per 50 grams of dry weight of de-ionized water.

Anaerobic Reactor. An anaerobic reactor requires an oxygen free environment due to the contained organism's sensitivity to this gas. The fermentation of organic compounds such as cellulose is one of the main anaerobic reactions. Cellulose makes up the cell walls and fibrous intercellular material. There are three types of cellulytic material: cellulose, hemicellulose, and lignin. Hydrolytic bacteria are responsible for initially breaking the bonds in the complex organic molecules. After hydrolysis has occurred, the acid forming bacteria ferment the subunits into the organic acids, H₂ and CO₂ (Chynoweth, 1988). These molecules are then transformed into fuel. Ruminant animals, such as cattle and sheep, are capable of breaking down complex molecules like cellulose. These animals are the models on which anaerobic reactors have been based. The flagellated rumen protozoa, found in the termite gut, is also capable of digesting cellulose (Chynoweth, 1988). Cellulose is broken down by the enzymes produced by hydrolytic bacteria. These enzymes are exogluconase and endogluconase. Exogluconase acts on the outside chains of the cellulose

molecule whereas endoglucanase acts on the inside chains. The combined action of endoglucanase and exoglucanase produces cellodextrins. These smaller molecules are then transported into the cell for further catabolism (Chynoweth, 1988). Another molecule present in the biomass of plants is hemicellulose. Hemicellulose is a short branched polysaccharide (Chynoweth, 1988). It is degraded primarily by gram-negative, non-spore-forming rod and cocci found in the rumen of animals. Microorganisms such as *Bacteroides rumenicola* and *Bacteroides fibrisolvens* utilize D-xylan, a form of hemicellulose, as a carbon and energy source, as also does *Neocallimastix frontalis* (Chymoweth, 1988). The cement that keeps the cell walls of the plants together is lignin. Lignin constitutes 20-30% of the dry weight of plant cell walls and is resistant to anaerobic microbial degradation (Chynoweth, 1988). At high temperature and Ph, lignin is partially broken down into low molecular weight aromatic compounds. Anaerobic reactors, however, produce undesirable byproducts such as methane.

Cellulose Conversion Reactors. A cellulose conversion reactor is an aerobic process of converting cellulose into glucose. One of the benefits of this method, compared to anaerobic reactions, is the absence of waste gases such as methane. Certain microorganisms such as *Trichoderma reesei* produce enzymes such as exo-1,4- β -glucanases, endo-1,4- β -glucanases, and β -glucosidases, which can be removed and used to degrade crystalline cellulose (Cote, 1983). The cellulose chain can be reduced by enzymes to individual glucose molecules. The insoluble cellulose (after treatment in a leachate reactor) is reduced by endoglucanase and exoglucanase to cellobiose, which is then reduced by β -glucosidase to

glucose. The glucose may then be removed from the reactor by filtration or the use of semi-permeable membranes. These sugar molecules can be used as a caloric supplement for the crew or can be converted to other useful products such as fructose, a more palatable sugar. The enzyme glucose-2-oxidase from the basidiomycete *Oudemansiella mucida*, can form fructose from glucose. Glucose-2-oxidase is employed to form the gucasone, d-arabino-2-hexosulose, from glucose and O₂. The dicarbonyl intermediate is reduced chemically at the aldehyde carbon-1 to generate the desired product, fructose (Wise, 1983). The glucose can be used as a growth medium for edible fungi and may be used as an energy source for protein producing fungi. Another micro-organism useful in the production of cellulase is *Aspergillus fumigatus*. *A. fumigatus* is a known lignin degrader and has the potential to separate lignin from hemicellulose and cellulose. The enzyme production of *Aspergillus fumigatus* has been tested on substrates such as filter paper clippings, straw, and brewers' spent grain, by the department of Chemical Engineering at the University of Birmingham. The highest levels of enzymes were produced using straw as a substrate. Protein production levels were highest using brewers' spent grain at levels of 3.0 mg/ml and higher. Pretreatment of the cellulose material speeds up degradation. Milling, steam treatment and alkali treatment are effective means of speeding up the enzymes conversion times (Cote, 1983).

Edible Fungus

Edible fungus can be used to turn animal waste, dead wood, and plant debris into an edible

biomass. In CLLSS, waste from plants, fish (in aquaculture), and certain reactors that produce glucose, cellulose, hemicellulose and lignin, must either be stored or put to use. If edible biomass can be grown on these wastes, food conversion efficiency would increase dramatically as opposed to using the harvested vegetable crops as food. However, out of the nearly 2000 edible fungi, only 25 are adequate for human consumption. From these, 10 are used commercially as edible fungi (Wuest, Royse & Beelman, 1987). One of the most common is the genus *Pleurotus*. It may possible to adapt *Pleurotus ostreatus* and *Pleurotus florida* to CLLSS.

Cultivation. Most commercial *Pleurotus* cultivation is done using techniques that may not be possible in CLLSS. Substrates used in most testing are either dead or living trees, straw, wood pulp, or animal manure (Wuest et al., 1987). Some of the most productive yields come from straw substrates in a heated water solution with other added minerals. The *Pleurotus* converts lignin, cellulose, and hemicellulose directly from the straw to glucose for use as a major source for its growth, development, and structural support (Chang & Hayes, 1978). In CLLSS, plant waste can provide the lignin and cellulosic materials, while concentrated glucose from the enzyme cellulose reactor can be combined with fish waste (provides N₂) and other reactor wastes to complete the substrate.

Submerged Cultivation. Another possibility is that *Pleurotus* grows well and rapidly in submerged culture, or possibly aquaculture. Specifically, optimum growth for this case occurs in aqueous solution with 0.01%-0.10% concentration of sulfite liquor and about 5%-

6% concentrated glucose (Chang & Hayes, 1978). This may be a more advantageous method because of microgravity. Without having a submerged culture, ways will have to be determined to keep the substrate in a confined area, as well as the fungi.

P. ostreatus and *P. florida* Characteristics. Two candidates for CLLSS are *P. ostreatus* and *P. florida*. They are both characterized by high growth rates and high saprophytic colonization ability of mycelium. It takes 20 to 40 days for fruiting bodies to appear depending on conditions (Chang & Hayes, 1978). They also have very high yield rates. For one gram of substrate used, it is possible to get between 0.6 to 0.8 grams of mycelium (Wuest et al., 1987). In most research, *P. florida* has a higher yield than *P. ostreatus*, however, it is smaller and finer in structure. Depending on harvesting techniques, it may be more advantageous to have a larger and stronger mushroom. Another advantage is that breeding *P. ostreatus* is much easier than many other cultivated mushrooms (Chang & Hayes, 1978). The optimum growth temperature for *P. ostreatus* and *P. florida* is 30° C. A CO₂ concentration of 28% by volume in the air stimulates the growth of both fungi. Much greater or lower concentrations will inhibit the growth. The optimum pH for these fungi is between 5.5 to 6.5 (Chang & Hayes, 1978).

Hybrids. Pleurotus hybrids may be an advantageous alternative over the parent species. *P. ostreatus* hybrids give higher fruit-body yields and more luxurious growth, and "some hybrids between German and American *Pleurotus ostreatus* produce bigger and stouter fruit

bodies than pure American" (Chang & Hayes, 1978).

Aquaculture

In the broadest sense, aquaculture includes any type of plant or animal that lives in water. In CLLSS however, aquaculture studies are being done almost exclusively with fish. The two fish investigated for use in CLLSS were the Mozambique Tilapia and the channel catfish (*Ictalurus punctatus*). The Tilapia currently under consideration by CLLSS while the channel catfish is a wide spread farm fish.

Catfish Tolerances. Tolerance ranges for the catfish as compared to the Mozambique Tilapia show that the catfish is not as versatile. For the catfish, "...the incoming water should range between 24° and 29° C (75° and 85° F) and contain not less than 6 ppm of dissolved oxygen" (Brown & Gratzek, 1980). Comparing this to the temperature range of 14° to 39° C and the minimum dissolved oxygen level of 0.1 ppm for the Tilapia (Pullin & Lowe-McConnell, 1982), it is apparent that the Tilapia has much greater tolerance ranges than the catfish.

Human Involvement for Catfish Aquaculture. Assuming that the optimum CLLSS aquaculture will use the least amount of human involvement for its operation, one of the main factors is the time that humans must spend interacting with the aquaculture. Channel

catfish would require a great deal of crew involvement, thus we excluded it from CLLSS consideration. Examples of the human involvement that would be required are noted in the spawning and diet characteristics of the catfish. Regarding catfish spawning, "...special care must be taken to pair fish properly in pens and aquariums" (Brown & Gratzek, 1980). This is very important because catfish fight during spawning season (males and females fight). In a large aquaculture where exact pairing would be almost impossible, fighting would be unavoidable. Some bites break the skin of the fish and cause infections, whereas others are deadly (Brown & Gratzek, 1980). Infected meat is not fit for human consumption and is therefore a waste of resources. However, fighting may be avoided by yet more human involvement. If the female is given one to three hormone injections (acetone-dried pituitary material or human chorionic gonadotropin), the catfish can usually be induced to spawn instead of fight. This should only be done to females that are completely ready to spawn (Brown, 1977). Although the channel catfish is an extremely important commercial fish on Earth, it requires too much human involvement and time to include in CLLSS.

Tilapia Mossambicus. A descendant of the Cichlidae family and the Tilapia genus, the Mozambique Tilapia is one of many commercially important Tilapia species. However, the Mozambique Tilapia is felt to be one of the most important, if not the most important of the Tilapias. There are several factors why this fish would be an essential part of the integrated CLLSS system.

Size. *Tilapia mossambicus* is one of the larger Tilapias. Adults can reach a length of 40 cm.

(Grzimek, 1974). Because of the limited space within CLLSS, it is important to keep the size reasonably small. A size of 40 cm. would provide a good meat-bone ratio, whereas smaller fish may have a poor meat-bone ratio. A larger fish (30-40 cm.) would enable the food preparation group to remove a greater amount of meat in a specified time. For example, if a fish is used that yields one half the amount of meat as the Tilapia, twice as many fish will need to be cleaned for eating. Thus, the reasonably large size of the Mozambique Tilapia is an important factor for consideration for CLLSS.

Tolerances. Although the Mozambique Tilapia is a freshwater fish, it can adapt to saltwater easily. High salinity ranges, as well as wide temperature, pH, and dissolved oxygen ranges are all characteristics of this fish. Research has shown that the Mozambique Tilapia grows in salinities of 32 to 40 ppt, reproduces in salinities as high as 49 ppt, and can adapt to salinities up to 120 ppt (Watanabe, Kuo & Huang, 1985). This is an extremely high tolerance range for a freshwater fish. The normal temperature range that the Mozambique Tilapia lives in is between 14° and 39° C, however, it can tolerate a range of 8° to 42° C (Pullin & Lowe-McConnell, 1982). Probably the most important tolerance is the resistance to low dissolved oxygen levels. Mozambique tilapia can live and reproduce in a dissolved oxygen level that is only 0.1 ppm (Pullin & Lowe-McConnell, 1982). This extremely low oxygen level is enough to kill most other fish. Since the aquaculture in CLLSS is a controlled environment, salinity, pH, and temperature factors are not very important.

Diet. Possibly the major contributing factor to the decision of using the Mozambique

Tilapia is the fish's diet. Many fish (including some Tilapias) are specialized eaters. They only eat blue-green algae, phytoplankton, or other specific foods. Mozambique Tilapia, on the other hand, eats a wide variety of foods such as epilithic, epiphytic and filamentous algae, phytoplankton, diatoms, bacteria, zooplankton, small water insects and even some fish. The main component of its diet however, is made up of vegetable debris such as vegetative leaves, shoots, and roots (Pullin & Lowe-McConnell, 1982). After harvesting the PGU, the vegetable debris not harvested can be sent directly to the aquaculture as food, possibly with some minor processing (perhaps the fish would convert it more efficiently to waste and CO₂ if it were processed into a fine powder). If harvesting is done in large amounts in rapid succession, the inedible biomass would probably build up. The biological reactors that break it down into CO₂, glucose, etc. will not be able to process the debris at the same rate that it is accumulating. Mozambique Tilapia would be an excellent outlet for this accumulating debris. Even if the vegetable debris does not accumulate, some of it can be sent to aquaculture as food as well as to the reactors. Although actual figures are difficult to estimate, it has been shown that for several of the plant-eating Tilapia, approximately five to seven kilograms of plant material are required to produce one kilogram of fish meat (Grzimek, 1974). Considering the great amount of debris remaining after harvesting the edible food, much of it can be put to use by feeding the fish, thus providing a very protein-rich and stable meat source to the CLLSS crew.

Reproduction. Because of the adaptability and high reproduction rates of Mozambique Tilapia, they seem to be suitable for use in CLLSS. This Tilapia spawns in intervals of every

three or four weeks and in large numbers (Grzimek, 1974). Reproduction is started with a male digging a pit into which he spawns. The female then deposits eggs in the hole and scoops them into her mouth with the sperm to develop (mouthbrooding). Several complications may arise if an aquaculture is used in microgravity. In the area of reproduction, for example, a substrate would have to be designed that would allow the fish to reproduce. Because of the high reproduction rate of Mozambique Tilapia, some measures may need to be taken to prevent over-breeding (overpopulation). One method is to separate the young by sex when they are between three and five cm. long. They become sexually active when they are between eight and ten cm. long (Grzimek, 1974). After separation, they can mature in growth ponds for each sex. Also, "...normal growth and reproduction are constrained by increasing salinity" (Watanabe, Kuo & Huang, 1985) , and breeding can be inhibited by lowering the temperature of the water (Pullin & Lowe-McConnell, 1982).

Mixed Breeding and Hybrids. Although the Mozambique Tilapia is the most diversified of the Tilapias and seems the most likely candidate for the CLLSS aquaculture, there are possible alternatives that may be as good or better, but would have to be investigated. In many cases, combining several species together, or using hybrids of species is better than using single species. According to Grzimek (1974), breeding of the Mozambique, Macrochir and Melanopleura Tilapia together resulted in more efficient use of the natural nutrients in the pond. He also stated that production figures for these mixed groups are very large. Because CLLSS uses a controlled environment instead of a natural one, research would

have to be done with several species in several conditions to determine if it would be more efficient or not. It was also found that "hybrids of Mossambicus and Niloticus grow faster with better food conversion than either parent species" (Watanabe et al., 1985). Thus, hybrids may also be a superior alternative than single species.

CLLSS Implementation. The Mozambique Tilapia, with the possibilities of mixed breeding and hybrids, seems to be the best candidate for the CLLSS aquaculture. It is one of the most highly adaptable fish in the commercial industry because of its wide tolerance ranges and applications. It has several aspects that would benefit the CLLSS program. It is a good source of vitamins and proteins for humans as well as a good source of CO₂ and nitrogen for the plants. It is also a direct outlet for inedible plant debris that must be dealt with in the CLLSS program.

Proposed Subsystem

A biological system was chosen over a physicochemical system because a biological system can be an additional source of edible biomass (i.e. edible fungus and fish), and it can be maintained with relative ease (easy to reinoculate and few replacement parts needed). At the plant growth chamber the leaves are separated from the inedible biomass and transported to the press, where the leaves are crushed and a protein liquid is removed. The unpressed biomass and the remaining solid biomass from the press are taken to the leachate reactor where valuable minerals such as zinc and copper are extracted. The insoluble

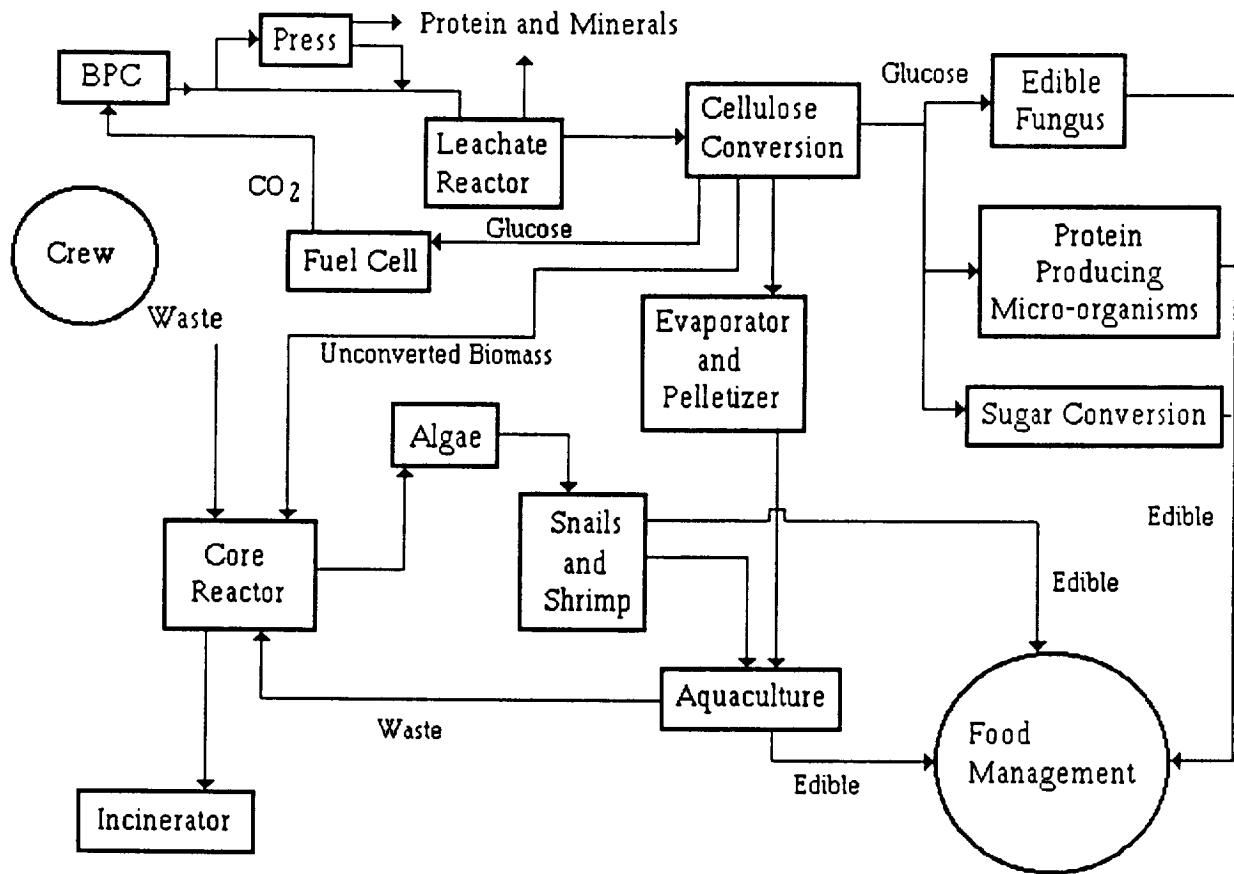

Figure 9. Resource Recovery waste recycling flow chart.

material from the leachate reactor is then transported to the cellulose conversion reactor. At the cellulose conversion reactor, most of the cellulose is converted to glucose, water, and carbon dioxide. The glucose removed from the cellulose conversion reactor is then either converted to sugar usable by humans, used to culture edible fungus, or used by protein producing microorganisms. Some of the unconverted biomass is dried, pelletized, and fed to the organisms in the aquaculture. All other unconverted biomass is sent to another more general bacterial reactor. At the core reactor the unconverted biomass from the plant waste is joined with the human waste. Although we have not thoroughly investigated a human

waste system we have decided that the waste should be aerobically processed through a series of reactors. These reactors contain microorganisms such as *E. coli* and *Proteus vulgaris* which break down protein from the sludge into smaller molecules. The microorganisms and sludge are then used by the algae as a source of energy. The algae and sludge is eaten by the shrimp and snails, which can then be sent to Food Management. In addition to the unconverted biomass from the cellulose conversion reactor, the organisms in the aquaculture will be fed nutrients removed from the press. Any remaining biomass that is not converted by the core reactor is transported to the incinerator and burned. The burned material must be minimized since it is irrecoverable mass.

REFURBISHING

Prepared By:

Pablo C. Gersberg
Todd Long
Robert N. Tullo

REFURBISHING

This report will investigate three basic systems--porous trays, porous tubes, and aeroponics--that have been considered for use in the CLLSS design from a refurbishing point of view. A discussion of refurbishing methods will then follow.

Tray (Flat Plate)

The first system proposed is a flat plate composed of a ceramic or porous steel material. The nutrient solution flows under the plate, and is drawn through the pores into the roots via capillary action and transpiration pressure.

Advantages and Disadvantages. The flat plate system works well under gravity but will have some problems in microgravity. The plants have little support, and the air blowing through the PGU can cause an uprooting problem. Since the nutrient solution is also an enriched food source for microorganisms, bacterial growth can cause a serious problem of pore clogging. Severe clogging will decrease the efficiency of the system, put unnecessary stress on the machinery, and reduce crop production. However, the plate is easy to work with because of the flat rectangular surface.

Tube

The tube system operates under the same basic principles as the tray except that the roots wrap around the tube, rather than lie on the surface of the plate. The tube is surrounded by a plastic wrap in which the seed sits, and a hard plastic molding which keeps the wrap on the tube.

Advantages and Disadvantages. The tube system adds support that the plate system lacked, but this is not an advantage as far as refurbishing is concerned. The tube system has numerous disadvantages from a refurbishing point of view. The design of the tube system is a series of tubes connected together. The tubes must be taken apart from the rest of the system which could cause problems for an automated system. All of the growth tubes will not be the same size and the refurbishing system must account for this. Since the tube system is a ceramic based system, pore clogging is again a problem. Finally, the tube is surrounded by a plastic wrap and covering. These must be removed before most of the work is done to protect the system from damage.

Aeroponics

In an aeroponic system, the plants are suspended and the nutrient solution is sprayed directly on the roots.

Advantages and Disadvantages. The aeroponic system offers numerous advantages with few problems. Most importantly, there are no pores to clean. There is the main spray nozzle which has a relatively large diameter and is considerably easier to keep unobstructed and clean than a large number of pores. Depending on the refurbishment technique used, the misting system can be utilized to facilitate the process. There is a problem of microorganism growth on the entire growth unit, rather than just in the immediate area of the plant. This can be remedied by washing the solution off the walls and drawing it out of the chamber. Also, depending on the orientation and position of the plant parts within the chamber, removal may be complicated.

Possible Refurbishment Techniques

Several techniques to clean out inedible biomass were investigated. The final refurbishing procedure will probably be a combination of these techniques.

Tray Refurbishing Techniques. The tray could be refurbished by the following:

- 1) Water/air under high pressure to blow plants off the trays.
- 2) A razor/stripping system to scrape plants off the trays.
- 3) A strong acid or base solution to dissolve plant matter.
- 4) Incineration to burn off plant matter.

Tube Refurbishing Techniques. The tray could be refurbished by the following:

- 1) Water/air system as above.
- 2) A ring system to slide along tube to remove plants.
- 3) Acid or base solution.
- 4) Incineration.

Aeroponic Refurbishing Techniques. An aeroponic system could be refurbished by the following:

- 1) Water/air.
- 2) Razor/stripping method.
- 3) Incineration.

The reason for not including acid/base solutions in the aeroponic system is that the system would have to be specifically constructed with materials that are capable of withstanding them. Materials such as ceramics which can withstand solutions with a pH between 2 and 12 would have to be used (Ambrose, 1990).

Recommendations. Certain techniques for plant matter removal can be removed from consideration. Since time is important in refurbishing, the technique of using acids or bases to dissolve the plant matter must be rejected. This process could take hours to days depending on the strength of the solution. Another disadvantage is that all surfaces in the

plant chamber must be corrosion resistant. One also must consider the effects of a highly caustic solution on the resource recovery reactors, particularly the ones employing living organisms. A razor or stripping system would complete the job quickly but could cause premature failure due to wearing down of the surfaces. As a result, maintenance and replacements to the growth system would increase. Also, the cutting or stripping surfaces must be kept sharp or the effectiveness of the system will be reduced. This problem can be overcome, therefore this system merits some consideration. The two remaining systems, however, show the most promise and will be examined in more detail.

Pressure Refurbishing system. By using a liquid or gas under high pressures and high velocities, the plant matter can be blown off of its support in the plant chamber. The principle employed is based on Bernoulli's equation, which relates the pressure energy, kinetic energy, and potential energy of a system:

$$(p/\rho) + 1/2 * V^2 + g*z = \text{Constant}$$

The gravitational contribution can be neglected due to the microgravity environment. When the fluid goes from a very high pressure to atmospheric pressure, the velocity of the fluid rises. If the fluid contacts a surface, the velocity goes to zero and the pressure equals the stagnation pressure. This results in a very large force, sufficient to loosen the plants from its attachment (Mei, 1990). Further research must be done to determine the proper direction of the fluid on the plant, yielding the best results with the smallest amount of

equipment. One of the best advantages of this technique is that it is nondestructive to the PGU, and it does not require specific materials for its construction.

Incineration. Incineration of the contained biomass is one feasible solution, especially for systems where ceramic materials are in use. A combination of moist heat and dry heat can be used effectively to ensure bacteria and plant virus death, as well as complete incineration of the organic biomass (Long, 1990). Prior to incineration, the inedible plant biomass should be finely ground or washed to ensure uniform heating. Large pieces of biomass will heat unevenly, and incomplete incineration will occur (Long, 1990). This can be done within the incineration chamber or transported to the chamber after being ground. The most efficient and rapid incineration can be accomplished using a combination of moist and dry heat. Moist heat will be applied first to effectively destroy the bacteria, viral infections, etc. that may be present, by damaging all of their macromolecular structures. Most likely, it would be applied as steam under pressure (121° C at 2.5 lb/in²) for about ten minutes. This temperature is required to inactivate any bacterial endospores that may be present, even though a temperature of 80° C is sufficient to kill most vegetative cells. The moist heat process is most effective if done in a container with no air (Long, 1990). After the ten minute moist heat procedure, an inlet will allow air to enter the container for the dry heat procedure, since burning requires O₂. Dry heat is the final step to the incineration process. It kills cells by desiccation, as well as denaturation of the macromolecules. It is also used for the sterilization of interior regions that can not be reached by moist heat (steam). Two approaches can be used for the dry heat process (Long, 1990). The first approach is for a

refurbishing process that can be allowed three to four hours for completion. In this case, the biomass is completely dried at a constant temperature of 140° C for two or three hours (or 200° for about one hour). A lengthy drying process such as this will reduce the concentration of smoke/vapor (N_2 , CO_2 , and H_2) that is given off during heating. The heat is then increased to the flash point for dried vegetation (approximately 310° - 340° C) for 20 to 30 seconds. If an open flame is used instead of heat, the flash point for dry plants will decrease by about 60° C. Complete incineration should occur under these conditions (Long, 1990). The second approach takes less than one hour. In this process, the heat is constantly increased to the flash point. However, heating a wet plant will cause a much greater concentration of smoke/vapor to be emitted in the form of H_2O , N_2 , CO_2 , and H_2 , as well as increasing the flash point by about 50° C over those previously stated. Thus, complete incineration will also occur in this approach, however, internal heat will be greater, and a greater concentration of smoke will be produced that must be contained (Long, 1990). The smoke is rich in H_2O , N_2 , CO_2 , and H_2 , and must be returned to the overall CLLSS system. Depending on the type of system that will be refurbished and the constraints on refurbishing time that are imposed, incineration is a viable system choice. The resulting matter is in the form of ash, however, which locks in vital minerals and carbon. This loss would most likely be unacceptable (Long, 1990).

Microorganism Refurbishing

Microorganism refurbishing concerns the reduction of bacterial propagation and the control of disease. The chamber can not be completely sterilized since some plants need certain bacteria to carry out important processes that the plants can not do themselves. For example, potato plants require bacteria to perform nitrogen fixation (Jones, 1990).

Microscopic Refurbishing Techniques. Microscopic refurbishing can be accomplished by the following:

- 1) Ultraviolet light.
- 2) Extreme heat/incineration.
- 3) Iodine and similar antiseptics.
- 4) Bleaching.
- 5) Highly acidic or basic solutions.
- 6) Biological control.

Advantages and Disadvantages. Antiseptics do not take much time and are efficient. Some of the chemicals are available from the resource recovery system or the NDS buffering system. Antiseptics can also be chosen to kill a specific microorganism rather than killing a broad spectrum. Bleaching will be just as effective but not as selective. Chlorine would have to be brought along and later retrieved by Resource Recovery. Ultraviolet light and

heating do the job well (possibly to the point of overkill), but do take longer. By a similar analogy, caustic solutions take time, and pose problems for the materials that may be used in the system. Biological control is a possibility but will most likely cause more problems than the one that it is trying to solve. One must also consider sterilization of the nutrient solution. If a disease or fungal growth develops, it is possible for it to enter the solution through normal cell processes. If this problem is not eliminated, infection to other plants in the chamber is possible. In the most extreme case, the entire crop would be lost, but it will most likely result in curtailed production or partial crop loss. A possible solution is to completely sterilize the solution after it passes through the chamber before it reenters the chamber.

Proposed Subsystem

To clean the PGU, a pressure system is recommended. The refurbishing system would be lowered into the chamber and oriented so that the plants are sheared from the supports. One fluid jet would be outside and tangent to the central cylinder of the PGU. The second is inside and would be positioned at a 45° angle so that the fluid contacts the chamber at the same point. The action of the inner fluid jet would expel the plant biomass from the seed holders. The jets would move along the rotating cylinder in the axial direction to clean out the entire PGU. The airflow through the PGU would propel the inedible biomass to the transport system, which can then be sent to Resource Recovery. Figure 10 shows a conceptual design of the PGU with the refurbishing system in place.

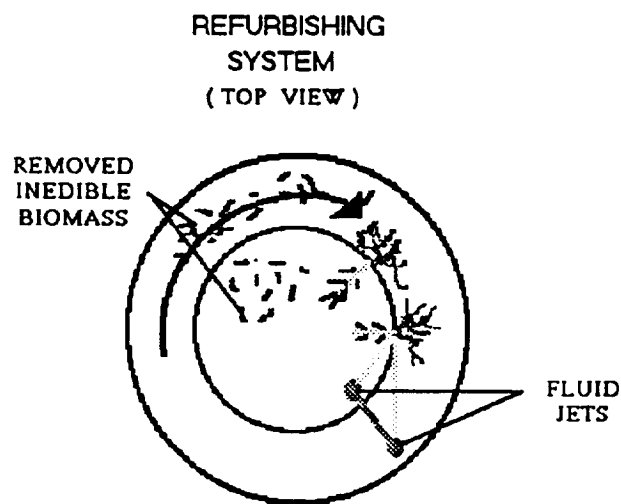

Figure 10. Conceptual design of PGU with Refurbishing system.

For refurbishing on the microorganism level, an antiseptic would be best to use because they are selective, readily available, and generally nontoxic to plants. For the extreme case of disease, ultraviolet light and/or heat over an extended period of time could be used to sterilize the system.

TRANSPORT

Prepared By:

Pablo C. Gersberg
George E. Richert, Jr.

TRANSPORT

Transport in a biomass management system, such as the one being proposed, is vital to the CLLSS mass balance. The transport group is concerned with the movement of liquids, gases, solids, and slurry between the four main units: Planting and Harvesting, Resource recovery, Food Management, and the Crew Compartment (Fig. 11).

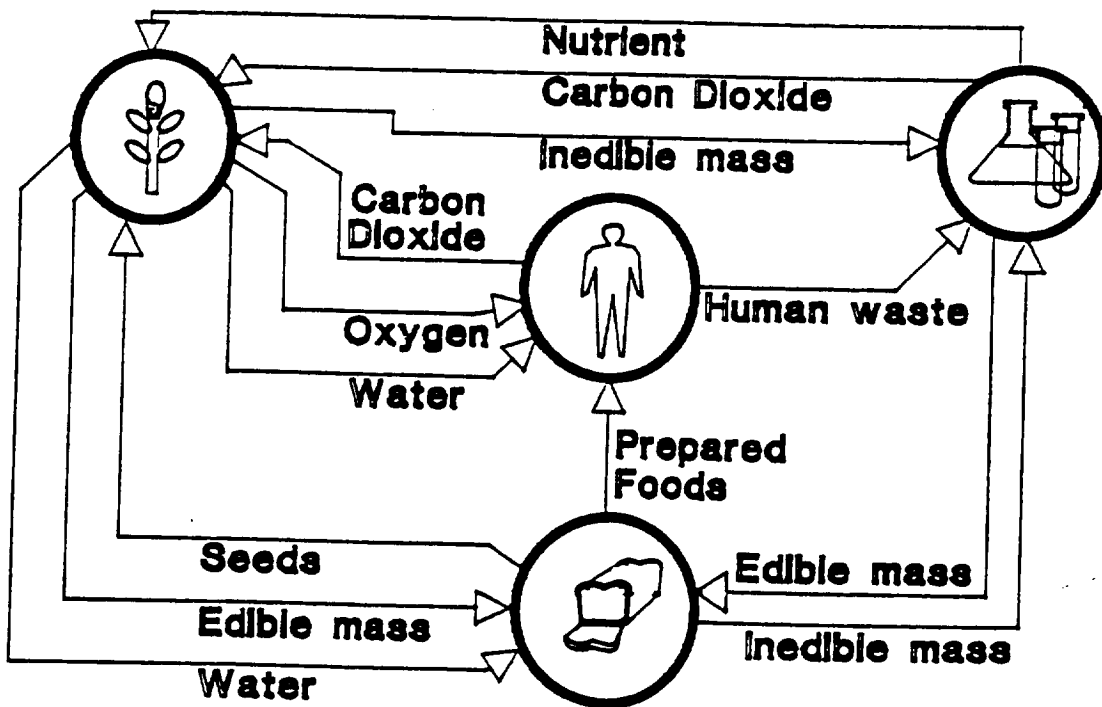

Figure 11. Substances to be transported within the BMS.

A complete listing of these substances can be found in Table 5.

Table 4. Substance, state, origin, destination, and quantity of substances in the transport system (Tibbits, 1982/EGM 4000, 1987).

Substance	State	From	To	Quantity kg/person day
Nutrient	L	RR	PHR	(480.00)*
CO ₂	G	RR	PHR	6.40
	G	CC	PHR	1.00
O ₂	G	PHR	CC	0.84
H ₂ O	L	PHR	CC	22.08
	L	PHR	FM	0.72
Prepared Food	S	FM	CC	0.62
Edible Mass	S	PHR	FM	2.34
	S	RR	FM	0.30
Inedible Mass	SL	PHR	RR	15.63
	SL	FM	RR	1.80
Seeds	S	FM	PHR	0.23
Human Waste	SL	CC	RR	23.64

S=Solid, L=Liquid, SL=Slurry, PHR=Planting/ Harvesting/ Refurbishing, RR=Resource Recovery, FM=Food Management, CC=Crew Compartment

* The nutrient solution from Resource Recovery to the Plant Growth Unit is not 480 kg/person day; however, it is the necessary amount to complement that solution circulating within the plant unit.

This report will present possible solutions, created under specific guidelines, for a CLLSS transport system.

Guidelines for Transport System Designs

The proposed systems follow these automation and equipment guidelines:

1. **The transport routine shall employ minimal use of human activity.** No substantial benefits are foreseen in having the crew perform the transport task.
2. **Equipment repair and maintenance shall be performed by the crew.** Proper functioning of transporting machinery is essential to a successful mission. The crew should be capable of repairing and maintaining the system in proper functional form.
3. **All functions shall be provided by system-sensing monitoring.** Control, distribution, and measurement of the transported mass should be conducted by a computerized system through appropriate sensing devices.

Liquid Mass Transport System

This system deals with potable water and nutrient solution. The system for liquid mass transport uses existing technology.

Water. The system for transporting potable water from the Planting/Harvesting atmospheric control system to the Food Preparation unit and the Crew Compartment must assure a contaminant free medium. The system must also move large quantities with no losses.

Nutrient Solution. The nutrient solution that will be moved from Resource Recovery to the Planting and Harvesting Nutrient Delivery system will only serve to replenish the deficient, constantly circulating nutrient solution contained within the Planting and Harvesting unit.

System. Transport of these liquids will be accomplished by adapting the traditional methods of pumping, valving, metering and piping to accommodate microgravity effects on the fluid dynamics. Some special problems will be encountered in implementing this system, such as liquid - gas separation in microgravity, which merits the further development and use of such devices as the zero gravity hydrophobic/hydrophilic bubble separator (Lamparter, 1970).

Gaseous Mass Transport System

A system is needed for the transport of carbon dioxide and oxygen. The transport system for gases adapts existing technologies. Air handling within the crew compartment and plant growth chamber were not investigated.

Carbon Dioxide. Carbon dioxide must be moved from the Crew Compartment and Resource Recovery units to Planting/Harvesting.

Oxygen. Oxygen must be transported from Planting/ Harvesting to the Crew Compartment.

System. The technologies for the transport of gases are available and commonly used in the aerospace industry. Existing subsystems will be integrated as necessary for the transport of gases between the units, considering microgravity effects. Transport of gases could be performed at crew compartment pressure.

Solid Mass Transport System

This system deals with the transport of edible mass, seeds, and prepared food. Possible systems which could satisfy set requirements are the pneumatic tube system and the electromagnetic conveyor belt system.

Edible mass. The system for transporting edible mass must move solids from the Plant Growth Unit and from Resource Recovery to the Food Management Unit. Damage should be minimal to the mass being transported. The solids transported must be conveniently received by Food Management for further processing/storage.

Seeds. The seeds will be transported from the Food Management Unit to the Plant Growth Chambers for sowing. The transport mechanism should be compatible with planting mechanisms already devised. Care must be taken to avoid damaging the seeds.

Prepared Foods. Transport of prepared foods from Food Management to the Crew Compartment must account for the fragility of the mass and the ease of handling by the receivers.

System Requirements. The system for solid mass transport should comply with the following requirements:

1. Capacity of the container shall not be less than that required by the mass to be transported.

2. Spacing, direction, storage, and path of the containers shall be controlled by a computer.
3. Carriers must take the shortest route to their destinations.
4. Carriers must be routed in straight lines when possible.
5. Carriers must be routed by means of diverters or in-transfer units.
6. Failure of one carrier, route, or diverter shall not interfere with the normal functioning of any other carrier, route, or diverter.
7. Automatic recovery of a container will only be required after a transaction has been initiated and a failure occurs.
8. Routes must be constantly monitored for proper operational capabilities.
9. Preventive overload features will prevent containers from being dispatched to busy stations.
10. Automatic redistribution of empty containers will ensure supply of empty containers to locations of greatest need.
11. The entire system must prevent leakage of particles during all operations.

Pneumatic Tube System. The pneumatic tube system is illustrated in Figure 12. In this system, the container is inserted into a pipeline and moved to its destination via pressure differences. Due to microgravity, these pressures would probably be very low. The pneumatic tube requires few moving parts, however, a malfunctioning container could get trapped in inaccessible places within the pipeline.

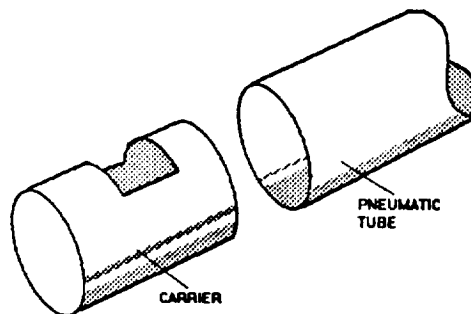

Figure 12. Pneumatic tube device.

Electromagnetic Conveyor Belt System. The electromagnetic conveyor belt system is illustrated in Figure 13. In this system, the container is transported while attached to electromagnets mounted on a conveyor belt. For removal of the container, those electromagnets in contact with it are deactivated. Unlike the pneumatic tube system, a failed container can be removed at any point of the route.

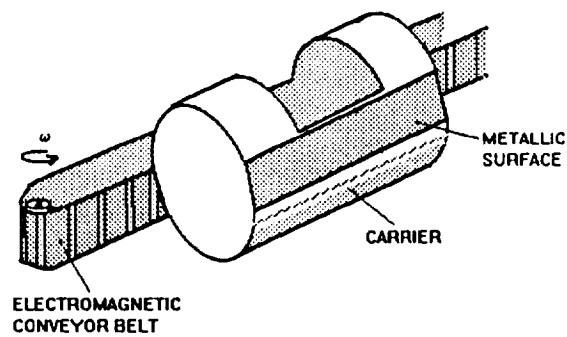

Figure 13. Electromagnetic belt system (conveyor belt attached to other side of carrier is not shown.)

Solid/Liquid Mixture (Slurry)

This group consists of the transport of inedible mass and human waste. The system for the transport of these substances consists of a slurry flow pipeline.

Inedible mass. The inedible mass must be transported from the Plant Growth Units and from Food Management to Resource Recovery. This mass consists of roots, leaves, and other plant debris not harvested. Along with the solids, refurbishing liquid will be encountered in the system resulting in a heterogeneous slurry solution.

Human waste. The human waste must be transported from the Crew Compartment to Resource Recovery. Human waste includes feces, urine, food mass, and water. This mixture also exists as heterogeneous slurry.

System. Due to the nature and quantity of the substances, a slurry flow pipeline is proposed as the transport mechanism. The carrier fluid will be water, complementing the existing liquid in the mixture. Centrifugal pumps are proposed as the driving mechanism, mainly because of their capability for series installation. For the proposed system, two pumps in series are recommended instead of one. If one pump should fail, then the additional pump can be brought into service and the slurry pumped through the defective unit. Repairs can then be conducted at a convenient time (i.e. while not refurbishing). The layout of the piping system must account for the type of pumping equipment employed, the physical nature of the flow regime of the slurry, and the regular maintenance operations. The choice of pipes must be made with regard to pressure, temperature, corrosiveness, and abrasiveness of the slurry. Valves should provide a full line-size opening and should not have dead pockets that can accumulate solids and thus restrict operation. Before entering the pipeline, the mass should be ground to reduce particle size in order to facilitate transport.

Conventional grinding equipment, with modifications for use in microgravity, can be utilized for this process. Inhibitors such as lignin or polyphosphates should be added to the carrier fluid to prevent corrosion. A test loop may be included in the pipelines for control. This would be a section of the main pipes. Pressure drop could be measured along with flow, temperature, and density to verify proper operation.

Proposed Subsystem

Existing liquid transport mechanisms such as traditional pumping and pipelining can be adapted for microgravity use, with the aid of such devices as the bubble separator. Current gaseous transport systems can be adapted for use in a microgravity environment. The pressures at which the gases are transported could be in the order of one atmosphere.

Due to the importance of the mass being transported--potential food material--the implementation of an open system, such as the electromagnetic belt-driven container system, is recommended for solid mass transport since it allows for removal of a failed container at any point of the route. The slurry flow system offers the advantages of moving a large quantity of a heterogeneous mixture without the need of separating the solid particles from the liquid. Slurry flow is currently employed in industry and it is expected that it can be adapted for microgravity use.

INTEGRATED BIOMASS MANAGEMENT SYSTEM

INTEGRATED BIOMASS MANAGEMENT SYSTEM

A preliminary design for a Biomass Management System was developed through the interactions of the subsystems proposed by Planting/Harvesting, Refurbishing, Resource Recovery, Food Management, and Transport.

Planting and Harvesting

Crops are planted and harvested in a cylindrical plant growth unit, where proper germination direction is achieved via rotation of the unit. Planting will be done using a minnow bucket process and NASA seed holders. Aeroponics will be used to deliver nutrient solution to the crops--lettuce, soybeans, peanuts, wheat, potatoes, and carrots--which are harvested by a combination of mechanical, automated, and human techniques. The edible mass is now ready to be transported to Food Management via the electromagnetic-conveyor belt system. The PGU may then be refurbished upon removal of all harvested material.

Refurbishment

The high pressure fluid delivery system will be used to clear the inedible biomass out of the chamber. After the plant matter has been disposed of, microbial growth in the PGU must be controlled so that it does not interfere with proper growth. Antiseptics will be used to reduce populations, and in the case of disease, electromagnetic radiation will be used to

sterilize the chamber. At this time the PGU will be ready for replanting. All of the inedible biomass will then be transported to Resource Recovery through slurry flow pipelines so that the raw materials can be recycled.

Resource Recovery

The leaves are separated from the inedible biomass received from the PGU and transported to the press, where the leaves are crushed and a protein liquid is removed. The unpressed biomass and the remaining solid biomass from the press are taken to the leachate reactor where valuable minerals are extracted by a solubilization process. The insoluble material is then transported to the cellulose conversion reactor where most of the cellulose is converted to glucose, water, and carbon dioxide. The glucose removed from the cellulose conversion reactor is then either converted to sugar usable by humans, used to culture edible fungus, or used by protein producing microorganisms. Some of the unconverted biomass is dried, pelletized, and fed to the organisms in the aquaculture. All other unconverted biomass is sent to the core reactor where it is joined with waste from the crew compartment. In the core reactor, a series of aerobic reactions break down the waste into smaller molecules that can be used as an energy source for the algae. The algae is then eaten by the shrimp and the remaining sludge is eaten by the snails. Along with the snails and shrimp, edible fungus and fish from the aquaculture are sent to Food Management.

Food Management

Food is input from three sources: food grown, food brought, food recycled from Resource Recovery. The food grown comes from the BPC and is transported to Food Management to be cleaned. Food brought includes any emergency food brought incase of low food production and flavorings, sweeteners, and colorings need for preparation of other foods. Food from Resource Recovery is mentioned in the above section. The units needed--cleaners, miller, chopper/shredder, oven/broiler/microwave, fluid immersion, pan fryer--will be used to convert raw material into food ready to eat.

REFERENCES

- Ambrose, J.R., Ph.D. (Material Science). Personal Interview. October 29, 1990.
- Arthur, Robert M. (1982). New Concepts and Practices in Activated Sludge Process Control. Ann Arbor, MI: Ann Arbor Science Publishers.
- Atkinson, B. (1974). Biochemical Reactors. London: Pion Limited.
- Barnett, A.J.O. (1980). Reactions in the Rumen. London: Edward Arnold LTD.
- Bennetto, H.P., Delaney, G.M., Mason, J.R., Roller, S.D., Stirling, J.L. and Thurston, C.F. (1985). The Sucrose Fuel Cell: Efficient Biomass Conversion using Microbial Catalyst. Bio-technology Letters, 7, 699-704.
- Bennetto, H.P., Thurston, C.F., Delaney, G.M., Mason J.R., Roller, S.D., and Stirling, J.L. (1985). Glucose Metabolism in a Microbial Fuel Cell. Stoichiometry of Product Formation in thionine - mediated *Proteus Vulgaris* Fuel Cell and its Relation to Columbic Yields. Journal of General Microbiology.
- Bennetto, Peter. (1987). Microbes Come to Power. New Scientist, 36-39.
- Brown, E. E. (1977). World Fish Farming: Cultivation and Economics. Westport: The AVI Publishing Company, Inc.
- Brown, E. E., and Gratzek, J.B. (1980). Fish Farming Handbook. Westport: The AVI Publishing Company, Inc.
- "CELSS Scenario Analysis: Breakeven Calculations." Mason, R. NASA Contract Report 166319, April 1980.
- Chamberland, Dennis, M.S. (CELSS System Engineer, NASA). Telephone Interview. November 21, 1990. November 23, 1990. November 30, 1990.
- Chang, S.T and Hayes, W.A. (1978). The Biology and Cultivation of Edible Mushrooms. New York: Academic Press.
- Chynoweth, David and Isaacson, Ron. (1988), Anaerobic Digestion of Biomass. New York and Basel: Marcel Dekker Inc.
- "Controlled Ecological Life Support Systems: Research and Development Guidelines." Mason, R.M. NASA CP-2232, May 1982.

"Controlled Ecological Life Support Systems: Transportation Analysis." Gustan, E. NASA Contract Report 166420, November 1982.

"Controlled Ecological Life Support Systems: Use of Higher Order Plants." Tibbits, T.W. NASA CP-2231, May 1982.

"Conveying Systems: Pneumatic-Tube System." CEGS-14580, Department of the Army, U.S. Corps of Engineering, May 1988.

Coppock, G. and Hedden, S. (1977). Citrus Harvesting in Florida. Proc. Int. Soc. Citriculture, 2, 393-397.

Cote, W.A. (Eds.) (1983). Biomass Utilization. New York: Plenum Press.

Cook, Harold T. "Refrigerated Storage". In: A. Johnson and M.S. Peterson (Eds.). (1974). Encyclopedia of Food Technology. Westport: AVI Publishing Company, Inc.

Crocomo, O.J.; Sharp, W.R.; Evans, D.A.; Bravo, J.E.; Tavares, F.C.A. and Paddock, E.F.. (1986). Biotechnology of Plants and Microorganisms. Ohio: Ohio State University Press.

Cross, Michael. (1986). Hope Despite Hiccup for Fuel Cells. New Scientist, 109, 26.

"Design of Components for Regenerative Systems for Growing Higher Plants in Space." EGM 4000 Engineering Design Class Report. University of Florida, 1987.

"Design Study of a Prototype Closed-Loop Life Support System." EGM 4000 Engineering Design Class Report. University of Florida, 1988.

"Development of Zero Gravity Hydrophobic/Hydrophilic Bubble Separators." Lamparter, NAS 1-8228, Biotechnology, May 1970.

Eckenfelder, W.W. and Santhanam, C.J. (Eds.). (1981). Sludge Treatment. New York and Basel: Marcel Dekker Inc.

Fellows, P. (1988). Food Processing Technology: Principles and Practice. Chichester (England): Ellis Horwood.

Flow and Level Handbook, The. Omega Engineering Inc., 1989.

Glaser, Peter E. "The Context for Food Service and Nutrition in the Space Station." In: R. L. Sauer (Ed.) (April 1985) Food Service and Nutrition for the Space Station. NASA-CP-2370.

Goldstein, Jerome. (1977). Sensible Sludge. PA.:Roldale Press.

- Golueke, Clarence G. (1977). Biological Reclamation of Solid Wastes. PA.: Rodale Press.
- Grzimek, Dr. H.C. Bernard. (Eds.). (1974). Grzimek's Animal Life Encyclopedia. Van Nostrand Reinhold Company, 124-140.
- Hall, Carl W., Farrall, A. W., and Rippen, A. L. (1986). Encyclopedia of Food Engineering. Westport: AVI Publishing Company, Inc.
- Harrell, R., Ph.D. (Agriculture). Personal Interview. November 8, 1990.
- Harrell, R., Ph.D. (1987). Economic Analysis of Robotic Citrus Harvesting in Florida. Transactions of the ASAE, 30, 298-304.
- Hollaender, A. (Eds.). (1981). Trends in the Biology of Fermentation. New York, Plenum Press.
- Jones, P., Ph.D. (Agriculture). Personal Interview. November 6, 1990.
- Kepner R.A., Bainer Roy, Barger E.L. (1978). Principles of Farm Machinery. AVI Publishing.
- Kurzweg, Ulrich. Professor of Aerospace, Mechanics, and Engineering Science. University of Florida. Personal Interview (November, 1990).
- Kingery, W.D., et al (1976). Introduction to Ceramics. New York: John Wiley and Sons.
- Lewis, Kenneth. (1966). Symposium on Bioelectrochemistry of Microorganisms. Bacteriological Reviews, 30, 101-113.
- "Life Sciences Research CELSS Project". NASA, Hanger L. 1986.
- Long, A.J., Ph.D. (Forestry). Personal Interview. October 28, 1990.
- Mei, R., Ph.D. (Engineering Mechanics). Personal Interview. November 14, 1990
- Moo-Young, Murray and Gregory, Kenneth. (1986). Microbial Biomass Proteins. New York: Elsevier Applied Science.
- National Aeronautics and Space Administration. (1970). Aerospace Food Technology. Washington, DC: Author.
- New, B.M. (1987). Feed and Feeding of Fish and Shrimp. Rome: United Nations Development Programme & Food and Agriculture Organization of the United Nations.

- Potter, Norman N. "Food Preservation". In: A. Johnson and M. S. Peterson (Eds.). (1974). Encyclopedia of Food Technology. Westport, Conn.: AVI Publishing Company.
- Pool, T. (1989). Motion Control of a Citrus Picking Robot. (Doctoral dissertation, University of Florida, 1989).
- Pullin, R.S.V. and Lowe-McConnell, R.H. (1982). The Biology and Culture of Tilapias.
- Robinson, W. (1980). Robinson's Country Series - Mushroom Culture. New York: George Routledge and Sons.
- Roters, Herbert C. (1941). Electromagnetic Devices. New York: John Wiley & Sons, Inc.
- Sager, John., Ph.D. (CELSS Director, NASA). Telephone Interview. November 21, 1990. November 24, 1990.
- Schugerl, Karl. (1985). Bioreaction Engineering. New York: John Wiley and Sons.
- Shackelford, J.F. (1988). Introduction to Materials. New York: Macmillan Publishing Company.
- Shaw, Lawrence Ph.D, Professor of Agricultural Engineering, University of Florida, Personal Interviews Oct., Nov. 1990.
- Shippen J.M., Ellin C., Clover C., (1980). Basic Farm Machinery. Pergamon International Library.
- Slavan, T., F. Lieing, and M. Oleson (1987). Controlled Ecological Life Support Systems Physiochemical Waste Management Systems Evaluation. CA, Ames Research Center.
- Smith, Donald P. "Equipment for Hot-to-Serve Foods." In: R.L. Sauer (Ed.)(April 1985). Food Service and Nutrition for the Space Station. NASA-CP-2370.
- Snyder, Harry E. and Kwon, T. W. (1987). Soybean Utilization. New York: Van Nostrand Reinhold Company.
- Sofer and Zaborsky, (1981). Biomass Conversion Processes for Energy and Fuels. New York: Plenum Press.
- "The Space Station Integrated Refuse Management System." 4505 Engineering Design Class Report. University of Central Florida, 1988.
- Stoner, R. (1983, September). Aeroponics Versus Bed and Hydroponic Propagation. Florists Review, pp. 49-52.

- Talbur, William F. and Smith, Ora (Eds.) (1987). Potato Processing. New York: Van Nostrand Reinhold Company.
- Tipson, R.S. (Ed.) (1988). Advances in Carbohydrate Chemistry and Biochemistry, 45,46, New York: Academic Press Inc.
- Volk, B., et al (1986). Essentials of Microbiology. Philadelphia: Lippincott.
- Wasp, Edward et al. (1977). Solid-Liquid Flow Slurry Pipeline Transport. Clausthal, Germany: Trans Tech Publications.
- Watanabe, W.O, Ching-Ming Kuo and Mei-Chan Huang. (1985). Salinity Tolerance of the Tilapias. Iclarm Technical Reports, 16(2), 19-20.
- Wheeler, R., Ph.D. (Plant Pathologist). Telephone Interview. November 20, 1990. November 21, 1990. November 27, 1990.
- Whitney, E.D., Ph.D. (Material Science). Personal Interview. October 29, 1990.
- Wilcox, O.W. (1937). ABC's of Agrobiolgy. New York: Norton and Co.
- Wilke, C.R.,(1983). Enzymatic Hydrolysis of Cellulose: Theory and Applications. New Jersey: Noyes Data Corp..
- Wingard, Lemuel B.; Shaw, Ching Hao and Costner, James F. (1982). Bioelectrichemical Fuel Cells. Enzyme Microbiological Technology, 4, 137-142.
- Wise, Donald L. (Eds). (1983). Organic Chemicals from Biomass. Menlo Park, CA: The Benjamin/Cummings Publishing Company Inc.
- Wuest, P.J., Royse, D.J, and Beelman, R.B.. (1987). Cultivating Edible Fungus. New York: Elsevier Science Publishing Company.
- Yalpani, Manssur. (1988). Polysaccharides: Synthesis, Modifications, and Structure/ Property Relations. New York: Elsevier Science Publishing Company.
- Young, Li. (1985). General design and analysis of multi-armed manipulator for tree-grown fruit harvesting. (Doctoral dissertation, University of Florida, 1985).

EGM 4001

ENGINEERING DESIGN II

Design of Components for Biomass Management
in a Closed-Loop Life Support System

Prepared for

National Aeronautics and Space Administration
Kennedy Space Center, Florida
and
Universities Space Research Association

May 1991

Prepared by

EGM 4001 Engineering Design
Department of Aerospace Engineering,
Mechanics and Engineering Science

EGM 4001

ENGINEERING DESIGN II

Design of Components for Biomass Management
in a Closed-Loop Life Support System

Prepared for

National Aeronautics and Space Administration
Kennedy Space Center, Florida

and

Universities Space Research Association

May 1991

Prepared by

EGM 4001 Engineering Design
Department of Aerospace Engineering,
Mechanics and Engineering Science

University of Florida
Gainesville, Florida 32611
(904) 392-0961

Instructor

Dr. Gale E. Nevill, Jr.

Editor

Pablo Gersberg

Assistant Editors

Todd Long

Sofia Lopez

EXECUTIVE SUMMARY

The goal of the Spring 1991 EGM 4001 Design class was to design, fabricate, and test components for biomass management in a closed-loop life support system (CLLSS). The designs investigated were to contribute to the development of NASA's Controlled Ecological Life Support System (CELSS) at Kennedy Space Center (KSC). Designs included an aeroponic plant growth unit with a hydro-refurbishing system, a transport container for biomass, and an air curtain system for fugitive particle control.

The plant growth and refurbishing group focused on the design of a Sectored Plant Growth Unit (SPGU), in which radishes were grown aeroponically and a hydro-refurbishing system was used to clean the device.

The transport group concentrated on the development of a Container and Receiving Mechanism (CARM), which allows for transport and transfer of biomass in a microgravity environment.

The fugitive particle control group examined the possibility of designing a device to keep particles from escaping a specific region.

The EGM 4001 class feels NASA will benefit from this cooperative venture. NASA received the interest and enthusiasm of engineering students. Recommendations provided will benefit future study in these areas.

ACKNOWLEDGEMENTS

The members of the EGM 4001 Design class appreciate the cooperation of the National Aeronautics and Space Administration and the Bionetics Corporation, particularly the following persons:

Mr. Dennis Chamberland (Primary NASA Contact)

Dr. William Knott

Dr. John Sager

Mr. Ralph Prince

Dr. Ray Wheeler

Dr. Richard Strayer

Mr. Thomas Dreschel

In addition, the supporting grant from the Universities Space Research Association is appreciated.

The contributions of the following faculty of the Department of Aerospace Engineering, Mechanics, and Engineering Science at the University of Florida were very beneficial in research performed by the Spring Design class:

Dr. Bruce Carroll

Dr. Harold Doddington

Dr. Robert Hirko

Dr. David Jenkins

Dr. Ulrich Kurzweg

Dr. Renwei Mei

The guidance of the following assistants and consultants at the University of Florida is also appreciated:

Barry Finger

Ara Manukian

Ronnie Rodriguez

The class would also like to extend a special thanks to the following staff of the Department of Aerospace, Mechanics, and Engineering Science:

Mr. Ronald Brown
Mr. Raymond Frier
Mr. Don Vinton

The assistance of the following individuals and organizations is greatly appreciated:

B and H Plumbing, Gainesville, Florida
Mr. Sigmund Berlant, Arenco and Augment, PompanoBeach, Florida
Bete Fog Nozzle, Inc., Greenfield, Massachussetts
Century Rain Aid, Gainesville, Florida
Mr. Tom Hill, Seal Master, Kent, Ohio
Mr. Rick Jones, Intermatic, Gainesville, Florida
Mr. Kenneth Lawson, Jr., Lake Worth, Florida

Finally, special thanks to Dr. Gale E. Nevill, Jr., for his support and guidance throughout the semester.

1991 EGM 4001 DESIGN CLASS

Andrew Bream
Isabel Chong
Robert Clement
Pablo Gersberg
Michael Hessel
Todd Long
Sofia Lopez
George Richert
Robert Tullo

INTRODUCTION

The EGM 4001 Design class has been working in conjunction with the National Aeronautics and Space Administration (NASA) and the Controlled Ecological Life Support System (CELSS) project, supported by a grant from the Universities Space Research Association (USRA). The research being done at the CELSS facility has focused on the development of a closed-loop environment capable of sustaining plants and humans for a long-term space mission. The Spring 1991 Design class has concentrated on designing, fabricating, and testing devices that would integrate into a CELSS.

Goals

After conducting studies for the design of a Biomass Management System (BMS) in the Fall 1990 semester, the class determined some areas of the life support system which could benefit from actual observations and data gathering. The areas of interest included the development of:

- An aeroponic plant growth unit with a hydro-refurbishing system;
- a container and receiving mechanism to transport and store solid matter;
- and a system for fugitive particle containment and disposal.

The goal was to build working prototypes of these systems.

Class Organization

The class was divided into three groups to fabricate and test the aforementioned units. Each group pursued its respective topic in order to accomplish the class goal.

Report Structure

The report is divided into three sections comprised of the three final group reports. These reports include conclusions and recommendations for future investigation.

TABLE OF CONTENTS

1. A Sectored Plant Growth Unit with Support Systems	1
2. A Container and Receiving Mechanism	40
3. An Air Curtain System for Fugitive Particle Control	57
4. Appendix: Photographs of Components for Biomass Management	80

1. A Sectored Plant Growth Unit With Support Systems

Prepared by:

Todd F. Long
Michael I. Hessel, Jr.
George E. Richert, Jr.
Robert N. Tullo

TABLE OF CONTENTS

Summary	3
Introduction	4
Overview	6
Previous Design Concepts	6
SPGU versus PGU	6
Development Ideas	8
Planting	8
Aeroponics	15
Harvesting	16
Refurbishment	19
Subsystem Tests	23
SPGU	24
Final Design	26
Planting	26
Aeroponics	28
Refurbishment	29
Overall SPGU	32
Results From Tests	35
Prototype tests	35
Conclusions	37
Planting	37
Opposing gravity	38
Germination	38
Refurbishment	38
References	39

SUMMARY

The goal of the Plant Growth group was to engineer the design of a plant growth unit in which planting, harvesting, and refurbishing would take place. The system that was designed, a Sectored Plant Growth Unit (SPGU), models a sector of the aeroponic plant growth unit conceptually designed for a Controlled Ecological Life Support System (CELSS), by the EGM 4000 Advanced Missions Space Design class, during the fall of 1990.

The unit provides a growth promoting environment for all stages of crop development. Seed holders provide support as the individual plants grow. The roots receive a nutrient solution in the form of a mist. The nutrient mist, along with separated plant particles (leaves, root pieces, etc.), are removed by the application of air and water pressure and velocity gradients.

The SPGU is cleaned by a hydro-refurbishing system that cuts the plant at the root line, discharges all material in the seed holders, and liberates the edible and inedible parts of the plant from the unit. After the crop is harvested, the inedible biomass is removed from the SPGU with high-discharge water and air jets.

INTRODUCTION

As the CELSS research continues on the ceramic growth medium, several complications have arisen such as pore clogging. It was a goal of the Plant Growth group to avoid the problems that the porous tube and tray projects at Kennedy Space Center have encountered, while not overlooking other problems inherent to an aeroponic and hydro-refurbishing system, such as clogging of the misting and refurbishing nozzles. Rather than overlapping current research or duplicating previous work, the development of the Sectored Plant Growth Unit (SPGU), a model of a segment of the aeroponic hydro-refurbishing plant growth unit, was a new approach to the same problem.

During the conceptual design phase of the project, growing plants in a microgravity environment, the Plant Growth group took into account the planting, harvesting, and refurbishing activities, and how they apply in an integrated system. In the fall of 1990, the group determined some of the necessary criteria for a PGU and suggested a possible design. In the Spring of 1991, the design was revised, a prototype was built, and the concept was tested in a SPGU. Radishes were chosen as the SPGU crop because of their relatively small size and rapid growth rate.

Several methods are already in use for planting crops in non-soil mediums, so little time was spent in designing a planting system for the SPGU. Likewise, harvesting, as an individual activity, received very little focus. By the design of the SPGU, harvesting is basically a continuation of the refurbishing process.

Although aeroponics is a proven method of plant nutrition, very little research has been performed using a vacuum system and pressure gradients to control the aeroponic mist flow. There are distinct differences between the SPGU and the Vacuum Oriented Nutrient System (VONS), currently being explored by Bill Cox at Kennedy Space Center. The SPGU is one unit containing many plants, rather than

many units containing one plant each, which is typical of VONS. In a microgravity environment, the vacuum may become important, providing a way to keep the mist in the nutrient delivery system. Also, little research has been performed on the use and effectiveness of water jets (knives) to clean organic and inorganic materials out of a plant growth chamber. Thus, considering the time constraints for the project design, the focus of the Plant Growth group was directed towards the unexplored aspects of a vacuum oriented, aeroponic plant growth unit employing a hydro-refurbishing system. As a result of research and development, the final design of the SPGU should be large enough so that the data can be extrapolated to a full-size PGU.

OVERVIEW

Previous Design Concepts

Some design concepts were carried over from the 1990 fall semester. The need for seed germination and plant growth to occur in the same location was established by considering the additional automation required by a relocating process. The use of aeroponics was also carried over with the logic that an easily refurbished PGU, with a very long operational lifetime, was more desirable than a complicated assembly of tubes and coverings, which must be disassembled before refurbishing; thus, limiting its lifetime. The NASA seed holder was abandoned for a new design, to be discussed later, that would provide more support for the plant, and would withstand the high pressure spray of the hydro-refurbishing system. The hydro-refurbishing system was also a previous design concept. When incorporated into the plant growth unit, it would function as a rapid, thorough, cutting and cleaning device, freeing all plant material in a matter of minutes.

SPGU versus PGU

The Segmented Plant Growth Unit relates directly to the PGU conceptually designed for use in CELSS. The PGU is a complete system of stem and root chambers that are separated by coaxial cylindrical surfaces. These surfaces have fixed and moving nozzles which provide an aeroponic mist for plant nutrients, and precise, high pressure sprays for refurbishing (Fig. 1.1). This PGU was designed for use in a large-scale food production process in a microgravity environment. By designing the PGU so a full chamber of mature crops could be cleared in 10 minutes, refurbishing time restrictions can be met. The SPGU represents, as the name implies, a sector of the PGU (Fig. 1.2). The SPGU served as a testing ground for vacuum oriented aeroponic nutrient delivery and hydro-refurbishing.

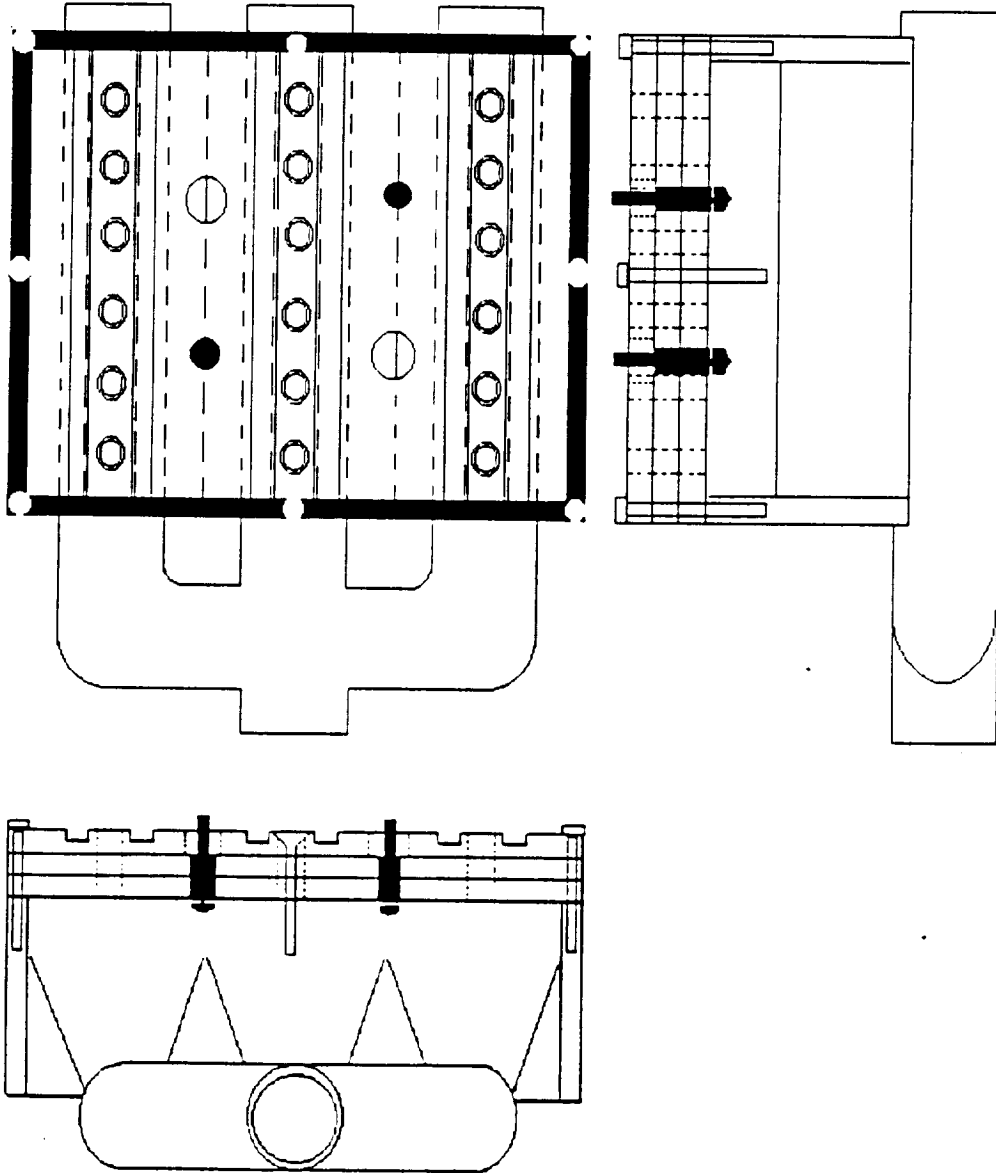

Figure 1.1. Three View Layout of SPGU.

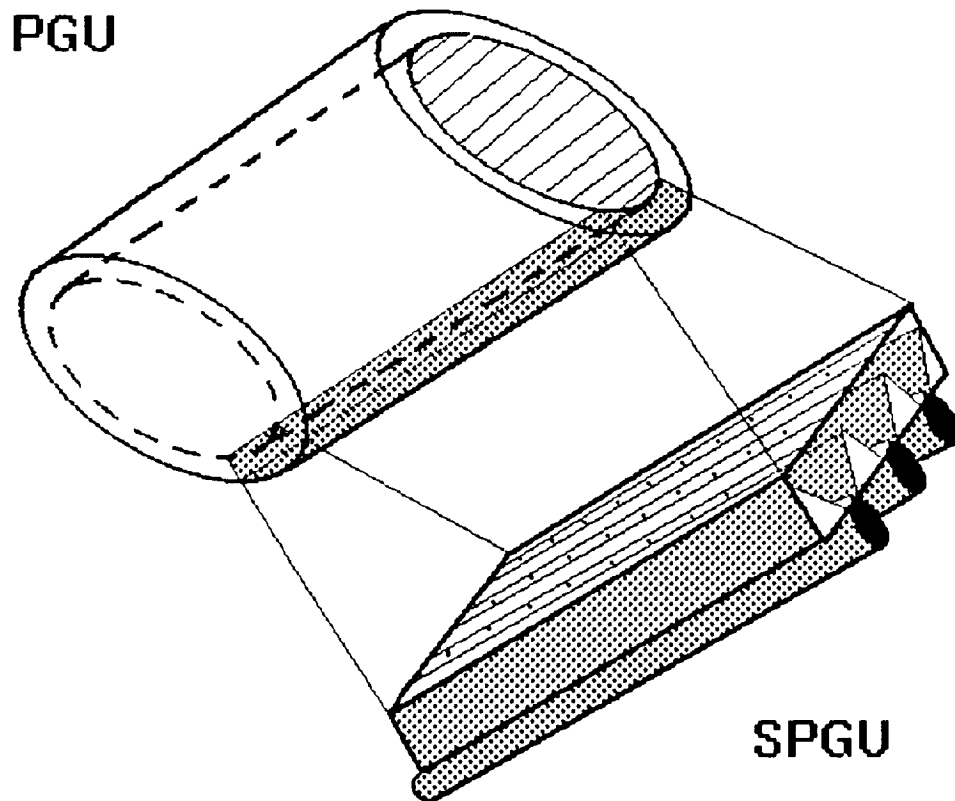

Figure 1.2. Relation of SPGU to PGU.

DEVELOPMENT IDEAS

Much time could be spent perfecting the intricacies of the SPGU and PGU. The strong desire to test and document larger concepts of the system has left some area for future work.

Planting

The placement of a seed prior to germination, and the orientation with which the plant grows after seed germination, are vital elements of a plant's growth and development.

Many factors such as light, air, water, pressures, and forces, will affect how the plant develops. Several methods were envisioned for possible planting schemes, seed containment, orientation, and germination. To save time, the design team proceeded under the assumption that one of the many available techniques could be modified for use in the full-scale PGU. Otherwise, future work would be necessary in perfecting the seed holder system; possibly from one of the seed holder designs presented here. Also, the design team felt it most beneficial and important to focus the majority of the research effort on relatively unexplored aspects of the system. With these factors in mind, the seed holder ideas are presented here with the possibility that one or more of the ideas could be perfected and used in an actual working PGU.

Peat pellet. At the beginning of the project, the main idea for the seed holder was to use an organic soil called peat, in which the seed would be embedded. The peat can be purchased in small cylindrical shapes called peat pellets. These dry peat pellets, approximately one and a half inches in height and about one and a quarter inches in diameter, come wrapped in a fine mesh material that holds the peat together. When the dry peat pellet is exposed to water, it expands as it soaks up the water, fitting snugly into the mesh lining. The purpose of these peat pellets is to provide the imbedded seed (pellets do not come with seeds in them) with a nutrient source and growth support. The pellets are then transplanted into the ground where the plant develops. The organic materials making up the peat provide the seed with many valuable nutrients. As envisioned for the SPGU, a peat pellet, or part of one, with a seed inside, would be pushed down inside the seed holder port, with the bottom of the peat pellet exposed to the aeroponic nutrient solution in the root chamber as shown by Fig. 1.3. In this case, the peat pellet is the seed holder. Providing that the peat pellet would remain within the seed holder port, and not get pulled through by the nutrient solution recovery vacuum, the seed holder would operate as follows: the peat pellet soaks up nutrient mist from the root chamber, then it expands and fills the seed holder port, ideally securing it within the port.

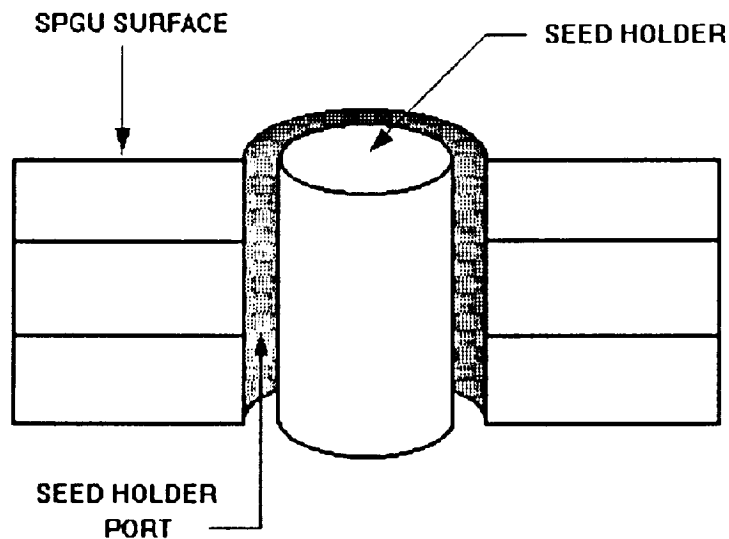

Figure 1.3. General Planting Scheme.

Although the peat would disintegrate slowly and get pulled out by the vacuum, the seed would germinate within the port and grow radially outward to secure itself within the port. A important reason for considering the peat pellets is that it may be possible to make them using the inedible biomass from a harvested PGU, in which case it would all be recyclable.

However, other factors surfaced that suggests that the peat pellets may cause problems within the SPGU. Because the seed holder ports must be small enough in diameter so that the seed will germinate and grow wide enough to fill the port's diameter, the peat pellet would have to be sculpted to an optimal size. Even though it was not tested, there is a good chance that the peat would dissolve quickly, allowing

the seed to get vacuumed out due to lack of support. Also, the nutrient recovery vacuum may be of a great enough strength that it removes the entire pellet from the port. Thus, it does not appear that the peat pellet would provide enough support or fixation for the seed within the seed holder port.

Three types of radishes were grown within the peat pellets. Cherry Bell, Early Scarlet Globe, and French Breakfast were all grown for some minor comparison testing. The radishes remained very immature and deformed (very thin), even after an ample maturation time. It was concluded that the mesh lining on the peat pellets provided enough pressure on the expanding peat to keep the radishes from growing normally. If the lining were removed to avoid this, it would be difficult to maintain the pellet's shape, especially in microgravity and with the application of a vacuum. Thus, due to foreseen problems such as size constraints, peat dissolvability, vacuum strengths, and growth inhibiting pressures within the peat pellet, the peat pellet was discarded as the SPGU seed holder. Although it may be an appropriate means of seed germination and growth within another system, it was not a feasible solution for the SPGU planting system.

Rough inner surface. Variations of the peat pellet, or other soil compositions, were also considered as seed holders for the SPGU. One idea was to make the surface of the seed holder port very rough. By doing this, friction between the port and seed holder would be increased, making the seed holder would be more secure within the port. In this case, the pellet would display more resistance to being pulled out by the vacuum. If the mesh lining could be altered in order to keep the peat from dissolving and diffusing through it, while providing enough room for peat expansion (to minimize compressive forces on the seed and root), the rough port surface may provide enough resistance to keep the peat pellet in the port. The diameter of the seed holder port may become an important parameter. Not only will the peat still dissolve, but a rough surface contacting the peat pellet could form a build-up of peat (dirt, etc.) along the cracks and grooves of the rough surface. Cleaning the seed holder ports after

harvesting would be much more difficult than with a smooth surface.

Bonding resin. Another possibility was to inject or mix the peat with a bonding resin or residue. A substance like this may be obtainable from another area of the Biomass Management System (BMS). By adding some kind of sticky, bonding substance to the peat, it would be more resistant to dissolving or diffusing (providing that the substance does not dissolve also). It would require testing to find a substance that would not dissolve in water, and would not bond so tightly as to interfere with seed germination and plant growth. A combination of sticky resin and peat would probably build up on the surface of the port. This would be very difficult to clean out if the resin could not be dissolved in the water of the hydro-refurbishing system. Because of the foreseen problems of both of these peat pellet options, the feasibility of using them in the SPGU seemed very low; thus, they were discarded as useful options.

Balloon. More mechanical ideas that were envisioned as seed holders include the use of small balloons. Regarding Fig. 1.4, two small balloons, or some other polymer device, would be placed within each seed holder port. They would take up the length of the port (from top surface to root chamber), and be placed on opposing sides of the port. This 180° orientation of the balloons would create the tightest seal between the balloons when they are inflated. After the balloons have been inflated and sealed, a seed may be pushed in between the two balloons towards the bottom of the port. Research would be required to determine how much inflation is necessary to keep the seed between the balloons, without causing excessive compression and inhibiting the growth of the plant. As the seed germinates, begins to grow, and displaces the volume that the balloons occupy, it may be necessary to deflate the balloons accordingly to reduce the compression felt by the plant. Also, maintaining seed wetness poses a problem. The peat pellets soak up water and thus, provide the seed with moisture; however, balloons may not allow water to be soaked up between them to provide moisture to the seed. In this case, a method would be required to deliver moisture to the seed. Although the idea of balloons as seed holders seems feasible

within an actual PGU, it poses mechanical problems. Sensing balloon inflation and seed wetness, and the testing required to perfect this idea, would require too much time and focus for this project; therefore, this planting scheme was also rejected.

INFLATABLE SEED HOLDER

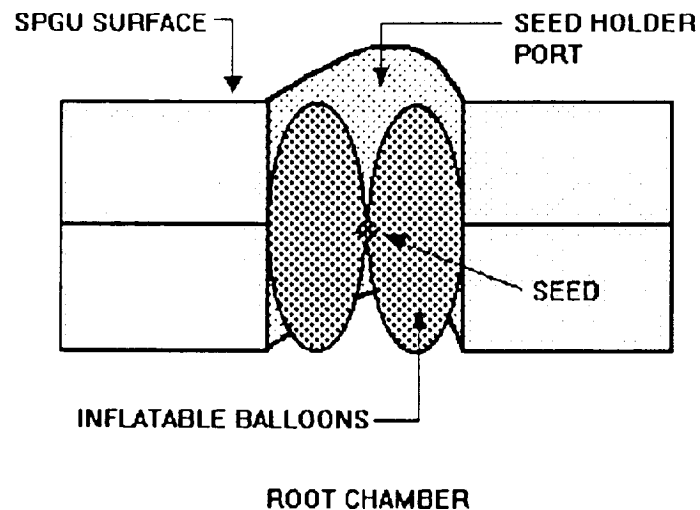

Figure 1.4. Inflatable Balloon Seed Holder.

Polymer Funnel. Another conceptual seed holder design involved a flexible rubber, or other polymer, shaped as a funnel, and open at both ends. The opening at the small end would have a smaller diameter than the seed to be used (Fig. 1.5). The seed would then be forced down into the small flexible opening, where it would be secured in a fixed orientation. In this case, moisture would not be a problem, since the seed would be directly exposed to the aeroponic mist in the root chamber. Several problems have been foreseen with the polymer funnel method. Some type of rubber,

or other polymer, would have to be used that is flexible enough to expand around the seed, and the plant as it grows, but rigid enough to keep a firm grip on the seed, not allowing it to slip through the small funnel opening. If the material is too rigid, it may produce excessive compressive forces on the seed or plant and inhibit normal growth. The funnel material would have to be extremely resistant to creep deformation. Ideally, it should return to its original shape without any deformation after every use. However, over a multi-year space mission, hundreds of planting cycles would be performed, placing a great deal of strain on the funnels. If they were not creep resistant, funnels would have to be replaced periodically. Due to the mechanical and material research needs foreseen in using polymer funnels, it was also neglected as a SPGU planting scheme. It would require a great deal of testing to determine ideal flexibility, rigidity, creep resistance, and shaping of an ideal polymer funnel seed holder. However, if all the testing and research could be done, it seems that the funnels would require very little maintenance and monitoring in actual use.

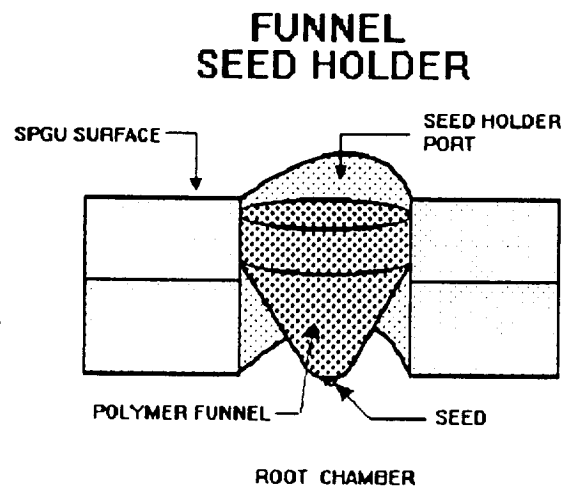

Figure 1.5. Polymer Funnel Seed Holder.

Filter Paper. The final seed holder idea was much simpler, and more feasible for use in the SPGU. The seed holder was a piece of filter paper, cut to a specific design, pushed down into the seed holder port, and attached to the port or top surface of the SPGU. This would create a pocket within the port in which the seed may be dropped. In microgravity, the seed would not escape out of the port because the vacuum would pull air through the filter; thus, the seed would be forced to stay at the bottom of the pocket. The filter would also absorb the nutrient mist and keep the seed moist since they would be in direct contact. Filter papers remain very strong even when they are wet; minor tests showed that the filter paper could withstand the full flow from a water faucet and not rip or tear under the force. Thus, it is feasible that a wet paper filter could support a small seed, and keep it from being pulled through the filter by the vacuum. Upon germination, the vacuum should aid in forcing the roots down into the root chamber.

The shape of the filter placed in the seed port has several possibilities. A small round piece, pushed in at the middle, would create a seed pocket. A rectangular piece would result in a loop shape when pushed into the port. However, an adhesive would be required at the bottom of the loop (where the seed rests) to keep the seed from being pulled around the side of the loop by the vacuum. To avoid this, a cross shaped paper filter could be used. When pushed into the port at the middle of the cross, the four segments of the cross bend up (along the sides of the port), producing a little cup shape in which the seed could rest. Unlike being enclosed on only two sides as in the single loop idea, the seed would be surrounded on all four sides. Because of the apparent simplicity of making a seed holder from a paper filter, the design team decided to employ this seed holder concept within the SPGU.

Aeroponics

When the roots of plants are supplied with nutrients by placing them in a liquid nutrient solution, it is called hydroponics. When a nutrient mist is allowed to saturate the roots, then drip off, it is generally called aeroponics. Some forms of existing nutrient

delivery are saturated non-soil mediums, porous tubes and trays, and Vacuum Oriented Nutrient Systems (VONS).

The type of nutrient delivery employed in the SPGU is a hybrid of both aeroponics and VONS. The VONS system, now being explored by Bill Cox, was designed for use in microgravity. It is based on the principles that if a closed chamber containing the root system of the plant is supplied with a nutrient solution in liquid form, as well as a vacuum, the roots will receive nutrients and the solution will be recovered back into the system. Applying these two basic principles, VONS may be considered to operate in a hydroponic or aeroponic mode, depending on the environment. There are some disadvantages of VONS. The system employs many small diameter vacuum lines which may be plugged with root tip pieces or other plant debris. The system also consists of many small, one-plant chambers, which would prove very difficult to refurbish in any large scale growing scheme. The nutrient delivery system developed for the SPGU possesses the best aspects of aeroponics and VONS. The system allows the growth of many plants in one chamber, supplies the roots with nutrients by a misting action, and employs a vacuum for nutrient solution recovery. The system was developed for use in microgravity by designing the actual plant growth unit with certain specifications. Nutrient solution was not to escape from the root chamber, except through the vacuum, regardless of its orientation when being tested on earth. Other specifications on the SPGU with respect to planting, harvesting, and refurbishing in microgravity also shaped its design, and will be discussed later.

Harvesting

According to the proposed Biomass Management System of the fall 1990 semester, harvesting is the removal of all edible biomass from the PGU. The harvesting method proposed by the fall semester's design team was a combination of manual, mechanical, and artificial intelligence methods. The harvesting method ideas for this semester's SPGU are different from the previous semester's ideas, largely due to the fact that the SPGU design is for radishes, or possibly other root or tuber crops.

Chosen for its small size and rapid growth, the radish has some special considerations; the part that must be harvested is in the root chamber, instead of above the root line. The root chamber in the SPGU is an enclosed, narrow, and relatively small area where the roots are misted by the aeroponic system. Due to the limited space, it would be nearly impossible to operate machines and perform mechanical or artificial intelligence harvesting in the root chamber. Likewise, it would also be difficult to perform human harvesting. This made it necessary to consider some other harvesting options. Not only would the harvesting technique be different, but it would occur during or after refurbishment of the SPGU. Again, this is different from the fall semester's proposal which had refurbishing following harvesting. Considering the SPGU, refurbishment basically involves the separation of the plant stalks and leaves from the roots by cutting the plants at the top surface of the seed holder ports. This leaves the roots remaining in the root chamber, separated from the rest of the plants. At that point, harvesting could occur, removing the edible roots from the chamber. In a sense, harvesting is just a continuation of refurbishing (cleaning out the SPGU) in this system.

Although harvesting must be performed in any plant system to remove the edible part of the crop for consumption, the goals of this semester's design team did not include the perfection of an actual SPGU harvesting system. As mentioned previously in the planting section, the focus of research and design was placed on the relatively unexplored aspects of hydro-refurbishing (separation of root from rest of plant using a water knife) and a vacuum-oriented aeroponic system. However, a SPGU harvesting system did receive some consideration. Because of time constraints, a working harvesting system could not be integrated into the design of the SPGU. If integration could occur at a later time, the SPGU design team has envisioned a harvesting scheme. Operating on similar principles as the hydro-refurbishing system, harvesting could be accomplished using a system of water and air jets. In microgravity, the roots would either be floating within the root chamber, or stuck onto chamber surfaces by cohesive forces of water. It would require little force to move the roots through the

chamber and out of the SPGU, using jets or nozzles with relatively low flow rates and pressure characteristics. By the SPGU design, a full cone nozzle would be placed at one end of a plant section. If one full cone nozzle could not cover enough radial area to contact and move the roots, more than one nozzle could be arranged at the beginning of the chamber. For example, regarding Fig. 1.6, if a root were floating directly above harvesting nozzle 2, the nozzle spray would probably miss the root. Then nozzles 1 and 3 would be required to insure that the root could be moved towards the outlet. The harvesting nozzles would force the roots to move down the root chamber in a direction parallel to the plant rows.

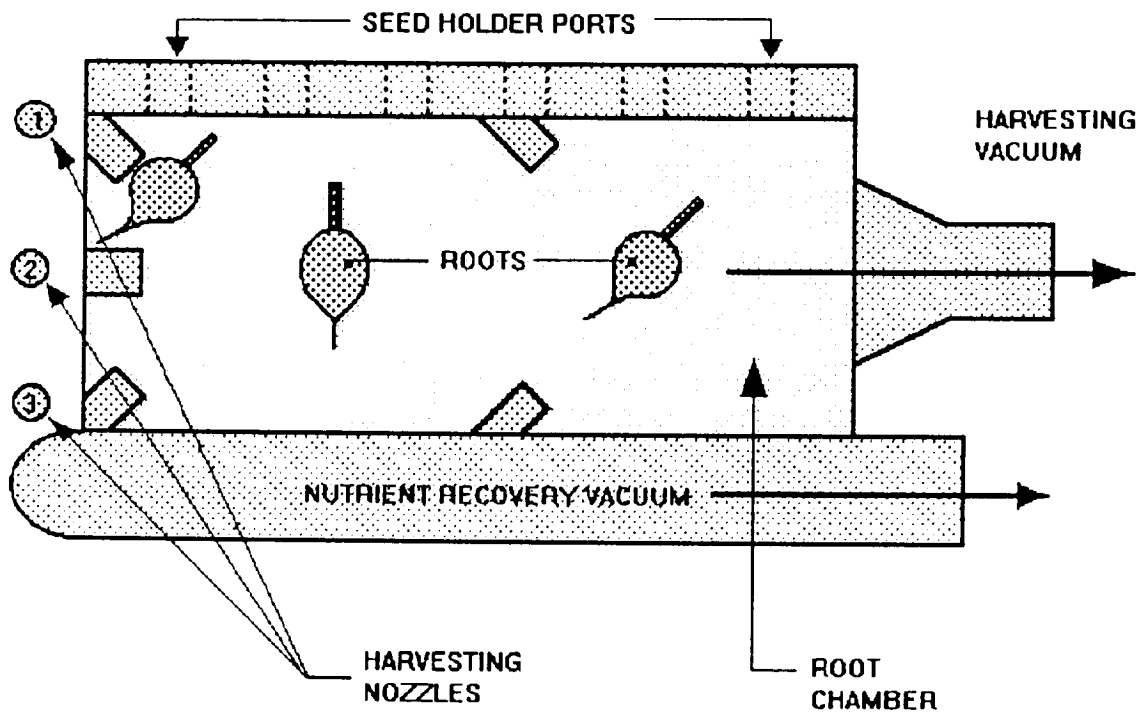

Figure 1.6. SPGU Harvesting System.

If a plant section were four feet or longer, as in a full-scale PGU, more nozzles may be required along the length of the chamber to insure that the roots will move towards the outlet. A vacuum may also be applied at the harvesting outlet as seen in Fig. 1.6. Since objects can be moved easily in microgravity, the combination of water nozzles and a vacuum would pose no problem in removing all of the harvested roots. The application of air nozzles and the vacuum could also be used to remove excess water out of the chamber. This harvesting vacuum should not be mistaken for the aeroponic vacuum. While the harvesting nozzles and vacuum are running, the aeroponic vacuum should be turned off. If it is not, the vacuum will force the roots to the bottom of the chamber, hold them there, and make it much more difficult for the harvesting system to remove them. It is clear that this harvesting method is greatly different from the proposed methods of the fall semester's design. Although this method was not integrated into the SPGU, it could easily be accomplished with more time and research. It appears feasible that it could be adapted to a full-scale PGU.

Refurbishment

Cleaning the PGU is a serious problem. Currently, it takes a group of six people a week to clean out the area required to feed one astronaut. Thus, a major design requirement would be to drastically reduce cleaning time. It was proposed to use water jets to clean the entire PGU within a matter of minutes. These water jets would be required to run at a high pressure in order to concentrate a large force over the desired area. Attempting to keep the hydro-refurbishing system small, the volume flow rate was specified to be under 1 gpm. The water knife would be used to cut off the top portion of the plant while another jet would free the root mass and remaining stem from the PGU. Ultimately, a sensor-based, intelligent system would carry and selectively aim the nozzles.

The plants would be grown in rows, and the refurbishing system could travel down these rows. One method of mimicking a sensor-based, intelligent system would be the use of a template that would guide the refurbishing system along a system of

tracks. This template would have one or more tracks corresponding to the rows in the PGU surface. It would allow for the refurbishing system to move along these tracks and from one track to another. The template could be placed at a certain height above the plant growth area. The refurbishing system would be suspended from it and guided along the tracks. Another possibility is that the template could be milled directly into the PGU surface (Fig. 1.7). In this case, the refurbishing system would move along the tracks in the PGU surface.

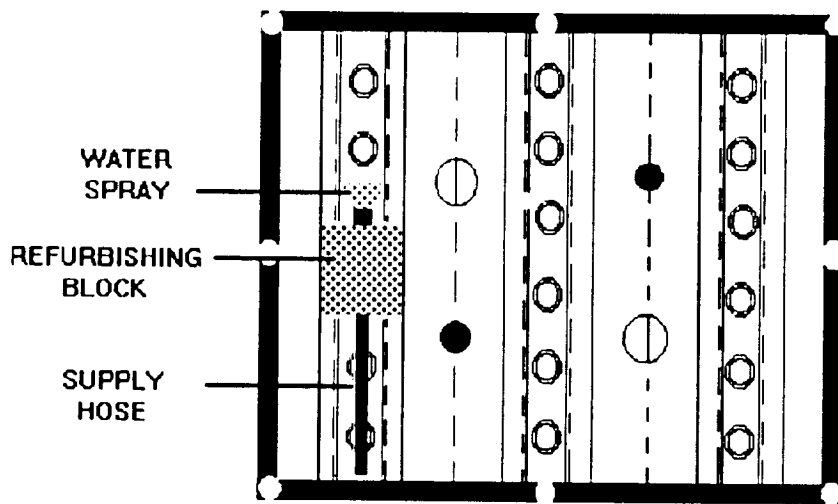

Figure 1.7. Refurbishing Tracks and Block on SPGU Surface.

The use of a pump was one method to deliver water at the high pressures needed. A pump would be small enough so that the refurbishing system would be portable. Finding a pump to meet both the pressure and flow rate requirements was possible; however, the cost was above the allotted budget. Thus, another alternative was to

use a pressurized holding tank. By using a container that can be pressurized, the water stored inside can be sprayed out through the nozzles. An advantage is that the container can be pressurized to whatever pressure is necessary for the refurbishing activities. A nitrogen tank in conjunction with a regulator was used to pressurize the storage container. The water pressure in the storage container can be varied with the regulator. There is a disadvantage to using this pressurized container refurbishing system. The area required to house the entire system is very large compared to the area required for a pump system.

The high pressure water knife is used to cut the plants at the SPGU surface, while another high pressure jet, directed down the seed holder port, removes both the seed holder and the biomass contained in the port. After blowing the root mass out of the seed holder port, it would be free of obstructions and planting could start again. After the plants have been removed from their support, they must be completely removed from the chamber. The use of air blowing through the chamber to remove the plants is a possibility. Above the root line, existing ventilation equipment is used to control the atmosphere. The same ventilation equipment could be used to help expel leaves and stems from the PGU. Additional equipment below the rootline would be used to remove roots and other plant debris from the root chamber. A possible solution could be nozzles spraying air and water down the chamber as previously mentioned in the Harvesting section.

Control Volume Analysis for Force on Radish Stem. In order to calculate the force required to be delivered by the water knife, a Control Volume analysis follows.

Assumptions:

- 1) The water jet from the cutting nozzle is steady, fully-developed, and incompressible. The radius of the water jet is described as: $R_j \leq 0.2 * R_p$ (radius of plant or stem). If this equation is satisfied, or $(R_p/R_j) > 5$, then the plant stem may be modeled as a flat plate; making calculations much easier.

- 2) The sum of all the body forces is zero. The pressure on all parts of the control volume are atmospheric, and therefore cancel.
- 3) The water jet radius (R_j) and velocity (V_j) are known.

Given:

Using the control volume shown in Fig. 1.8, the reaction force on the radish stem (R_x) can be found by the use of the continuity equation and the momentum equation.

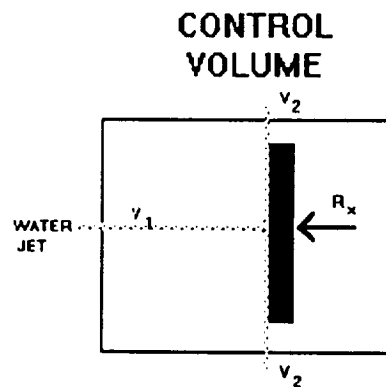

Figure 1.8. Control Volume Analysis.

Solution:

The continuity equation states that mass flowing through a control volume is constant. The momentum equation states that momentum is conserved in a control volume. Any difference is accounted for by forces acting on the control volume.

Continuity Equation

$$\int \rho V \cdot dA = 0$$

$$-\rho V_1 A_1 + \int \rho V_2 \cdot dA + \int \rho V_2 \cdot dA = 0$$

$$-\rho V_1 A_1 + 2 \cdot (\frac{1}{2} dm/dt) = 0$$

$$dm/dt = \rho V_1 A_1$$

Momentum Equation

$$\Sigma F_S + \Sigma F_B = \iint \rho u^* V \cdot dA$$

$$-R_x = \iint \rho u^* V \cdot dA + \iint \rho u^* V \cdot dA + \iint \rho u^* V \cdot dA$$

$$-R_x = -\rho V_1^2 A + 0 + 0$$

$$-R_x = -\rho V_1^2 A$$

Since the force produced by the water jet acts on the control volume, the reaction force is the one which counteracts it.

$$\text{Thus, Reaction Force} = R_x = -\rho V_1^2 A$$

By knowing this force, the pressure (or shear stress) needed to cut the plant can be found.

$$P = F/A = \rho V_1^2$$

Validity Check. For the refurbishing system, the radius of the water jet (R_j) is 3/64 of an inch, and the radius of the plant stem (R_p) is 1/4 of an inch. Thus, using the radius ratio described previously, $(R_p/R_j) = 5.33 > 5$. Since this ratio is greater than five, the stem may be modeled as a flat plate, and the assumptions made in the analysis are valid.

Subsystem tests

Some preliminary experimental testing was performed to aid in the design process. Information on the shear strength of radish stems was obtained. Pump and motor selection was also facilitated by some simple tests. Because of the high pressures required by the hydro-refurbishing system, some hydrostatic pressure tests were performed on the storage tank and piping to verify that they would not leak or fail under the high pressures.

Shear strength of radish stems. To determine the shear strength of radish stems, a simple device was designed and constructed. Three thin plates were assembled by fixing two together, and allowing the third to slide linearly between them. A hole with the diameter equal to the radish stem was then drilled through all three plates. A radish stem was inserted through the plates, and weight was added to the middle plate until the stem was cut. The test results indicated that a force of 10 lb. would be required to shear the average radish stem. This data was used to determine the operating pressure of the hydro-refurbishing system, to be discussed later.

Pump and motor tests. The nozzles of the aeroponic system could deliver up to six gpm at 30 psi. A rotary gear pump head, which is self-priming and works in a positive displacement fashion, was selected to pump the nutrient solution. An electric motor to power the pump was chosen after some testing. Specifications on the pump head indicated a one-half horsepower motor operating at 1725 rpm would be required. Numerous motors were coupled to the pump and tested in the system. A one-third horsepower, three phase, 1725 rpm motor proved to be the most reliable at delivering power to the pump. The motor was then permanently installed in the system.

Hydrostatic pressure tests. The hydro-refurbishing system, which consists of tanks, piping, valves, and nozzles, operates between 500 and 600 psi. To establish the reliability of the system to maintain a constant pressure, a hydrostatic pressure test was conducted. The system was filled with water and pressurized to 600 psi for several minutes, and to 1000 psi for several seconds. After the system was determined to maintain these pressures, it was specified that operating pressures should never exceed 600 psi. These specifications were made to insure reliable operation and safety.

SPGU

The main idea behind the SPGU is the containment of the nutrient solution in a micro-gravity environment while allowing the roots to come in contact with the solution. The

first design concept was a four foot long SPGU which would show the ease of all the refurbishing techniques, including cleaning the interior parts. Due to the time constraints of one semester, a compromise was made: Allow all of the refurbishing aspects to be tried, and neglect the cleaning of the interior. Thus, an eight inch by eight inch box (SPGU) was constructed out of clear plexiglass so that small-scale aeroponic and refurbishing tests could be clearly observed.

Equations. After consulting with professors specializing in fluid dynamics, a scheme for evaluating the parameters was devised.

Continuity Equation

$$\rho_1 V_1 A_1 = \rho_2 V_2 A_2$$

$$\frac{\rho_{\text{atm}} A_1}{A_2} = \frac{\rho_2 V_2}{V_1} \quad \text{Let } \rho_2 = \rho_{\text{atm}} \rightarrow \frac{A_1}{A_2} V_1 = V_2$$

Momentum Equation

$$R_x + P_1 A_1 - P_2 A_2 = \dot{m} V_2 - \dot{m} V_1$$

Assumptions. Utilizing engineering principles and attainable, conventional hardware, the following assumptions were used.

$$A_1 = 1 \text{ in}^2 \quad A_2 = .5 \text{ in}^2 \quad P_1 = 1.1 P_{\text{atm}} \quad P_2 = .9 P_{\text{atm}}$$

$$\rho_1 = \rho_{\text{atm}}$$

The results are SPGU specifications that are listed later.

FINAL DESIGN

Planting

Filter Paper. As concluded previously, the filter paper seed holder was the choice for use in the SPGU. With this choice, very few problems were foreseen. Mechanically, it was much simpler than using inflatable balloons or specially designed polymer funnels as seed holders, and it was much cleaner than using dissolvable peat pellets that would leave behind dirty films and residues. It was decided to use a cross-shaped piece of filter paper in each port. Due to the length of the seed holder port (distance between top surface and top of root chamber), the cross arms needed to be relatively long. One set of arms has a total length of about three and one quarter inches, while the other set has a length of about two inches. When the cross center is pushed down to the bottom of the port (top of root chamber), the four arms fold up along the inside of the port. The longer arms extend a small distance beyond the top of the seed holder port, while the shorter ones remain a small distance below the top of the port. One set of arms is shorter than the other so that it does not interfere with the refurbishing tracks on the SPGU surface. The ends of the long arms are then taped to the top surface of the SPGU. This secures the seed holder and prevents the vacuum from pulling it out of the port. The seed holder is positioned so that the long arms are folded down and taped between consecutive ports in a row. Looking down the port from the top, one would see a small pocket where the seed rests. This pocket, with the seed in it, actually protrudes a small distance down into the root chamber. This insures that the seed pocket and seed remain moist from the aeroponic mist in the root chamber. Since the cross arms are folded up 90° inside the port, this produces a square seed pocket, enclosed on all four sides. As a result, the vacuum is unable to pull the seed out of the pocket. Due to the filter strength, the vacuum is also unable to pull the seed through the filter, even when it is wet. The vacuum forces air through the port and the filter; thus, the seed remains at the bottom of the pocket. When the seed germinates, the roots will not have to break through the filter paper to grow

down into the root chamber, because the four cross arms are not permanently bonded to each other; thus, there are small gaps and spaces between the enclosing sides of the seed pocket. This allows the roots to grow through these spaces and down into the root chamber, while not destroying the filter and the seed pocket. Thus, if the germinating seed is not large enough to secure itself within the port, the seed pocket will still support the plant and prevent it from being pulled out by the vacuum. Since the aeroponic system and vacuum are not run continuously, but in brief, intermittent periods, the plant stem and leaves grow out the top of the port towards a light source, instead of being pulled down by the vacuum.

Perforated Plastic. Even though the filter paper planting scheme was implemented in the SPGU for the majority of the project design, one unforeseen problem led to a significant alteration near the project's end. The absorbency of the paper was initially thought to be a great advantage, by absorbing nutrient solution from the aeroponic system and providing the seeds and plants with plenty of moisture. Because it retained solution for the seeds and plants, it was assumed to be perfect for the SPGU. This was an ill-advised assumption made by the design team, neglecting a more thorough consideration of other options and possible disadvantages. After employing the paper seed holder in the SPGU, an unforeseen problem arose. Due to the paper's absorbency, solution was drawn all the way up through the port and onto the top surface of the SPGU, where the seed holder's long cross arms were taped down. The water from the solution evaporated, leaving a constantly growing, dry, nutrient residue on the seed holder's cross arms and around the port opening. If this residue continued to form, it would eventually plug the seed holder port (and seed holder), and form large deposits on the SPGU surface. In this case, it would probably prevent the right amount of light and air from reaching the seed or plant, and drastically inhibit the plant's growth. Also, depending on the solubility of the residue, it may be difficult to clean the SPGU surface and the seed holder port with the hydro-refurbishing system. To remedy this, an alteration was made to the seed holder by replacing the absorbent filter paper with a perforated plastic membrane. The thin plastic membrane

contains holes that are much smaller than any of the seeds used; thus, there is no danger of the seeds being pulled through the holes by the vacuum. As most plastics do, it tends to repel water (solution) rather than absorb it. Thus, there would also be no danger of the plastic seed holder absorbing the solution up through the port to the top surface. Thus, no residue should form on the surface or in the port. Although the plastic membrane repels water, the small holes let solution through them, allowing the seeds to remain moist, and grow properly. The same dimensions and details were used for this plastic membrane as for the paper. The only difference about the planting scheme is that the seed holder is a different material. Upon germination, the roots should be able to grow as described previously. Also, the roots may be able to grow through the small holes and down into the root chamber. Because of the strength of the plastic, the seed holder should offer great resistance to the vacuum. Although this was a small alteration, it should provide a feasible solution to the problems that the paper seed holder introduced. As with the filter paper, the perforated plastic seed holder was easily integrated into the SPGU, and worked well within the team's focus and time constraints.

Aeroponics

The SPGU has a functional anatomy. A nutrient solution mist is introduced into the root chamber at the root line by nozzles. The nozzles have a horizontal, 360° spray pattern. The root line is comprised of a perforated plate, a small air gap, and a solid plate. In order to straighten the incoming air, a plate with several small holes was used (perforated plate). To use the properties of a converging nozzle, for each row, triangles were used to lessen the area as the flow reached the vacuum side. The shape for each row is shown below. The vacuum draws air into the air gap, through the perforated plate (for uniform flow), across the nutrient spray, around the roots, and out of the chamber. The air flow acts to eliminate any nutrient solution from escaping the root chamber and to carry it back to the reservoir. The shape of the root chamber of the SPGU was designed to promote the desired flow of the nutrient solution and air, by using decreasing cross-sectional areas and pressure and velocity gradients (Fig 1.9).

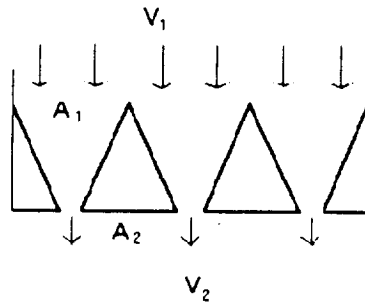

Figure 1.9. Velocity and Area Characteristics of Root Chamber.

Refurbishment

Overall System. For the final design, it was decided to use a hydro-refurbishing system driven by a pressurized tank. The refurbishing system was kept in line by a template milled into the PGU. A full water storage tank was then pressurized up to 500 psi. This was accomplished by hooking the tank up to the low pressure side of a regulator. The high pressure side was then hooked up to a nitrogen tank which was pressurized to greater than 1000 psi. By releasing a valve at the bottom of the pressurized tank, the water flows to the nozzles which then cuts the plants (Fig. 1.10). A nozzle with a fan spray cuts the plants at the surface of the SPGU. A straight jet nozzle blows plant debris and the seed holder out of the seed holder port. A metal block is used to house the two nozzles. Holes were drilled through the block to allow the water to pass through it, and out of the two nozzles mounted on the block (Fig. 1.11).

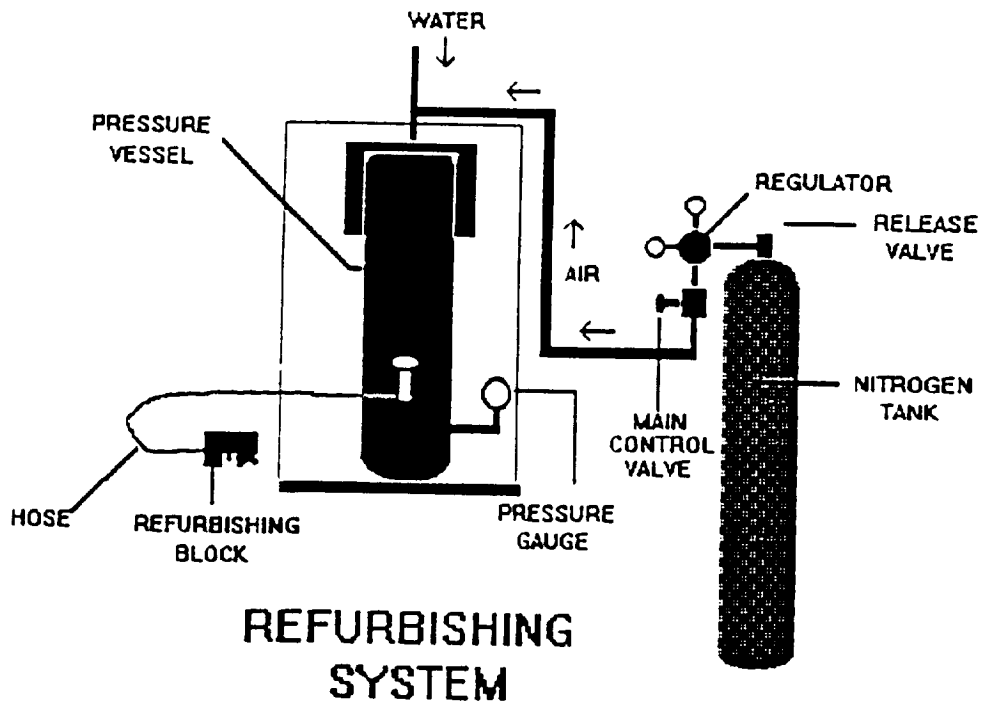

Figure 1.10. SPGU Refurbishing System.

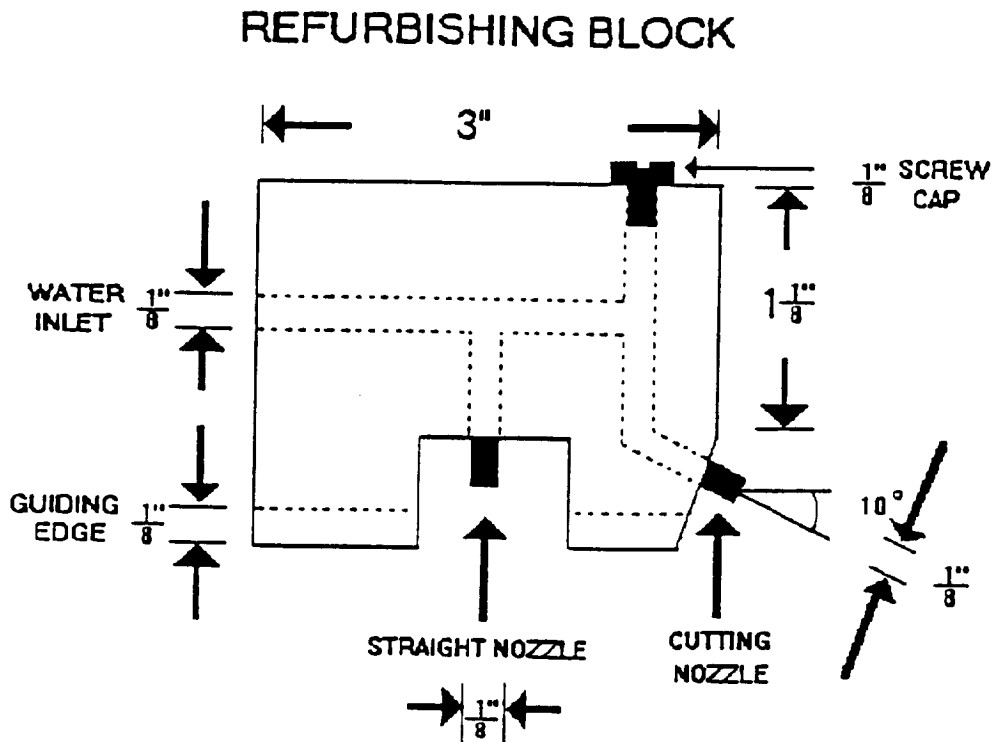

Figure 1.11. Refurbishing Block and Nozzles.

A very short, high pressure pipe was used to connect the nozzle block to the tank. By using a short connecting piece, pressure losses were greatly reduced between the tank and the nozzles. There are numerous valves that can be adjusted for more accurate control. In order to get the refurbishing system to work at its highest efficiency, especially keeping it a "one-pass" system, various nozzle types and angles of orientation were experimented with. During nozzle considerations, it was important to maintain low volume flow rates for ease of testing and miniaturizing the prototype size.

Cutting Nozzle. The fan nozzle would cut the plant most effectively if it were perpendicular to the stem. To cut the plant in a perpendicular direction, at the top surface of the SPGU, the cutting nozzle would have to be built half way into the surface. Since this is not possible with a moveable refurbishing system, it was agreed that a small angle (10°) would keep most of the energy in the spray acting in the horizontal direction, and allow for cutting at the base of the plant. After consulting with engineers in the field, it was determined that a nozzle with a $3/64$ inch diameter orifice, and a 30° fan spray pattern, would be able to cut the entire plant at the surface of the SPGU. A straight jet also received consideration and testing as the cutting nozzle. Due to the 0° angle of departure of a straight jet, there is very little dispersion of the water flow, unlike with a fan or full-cone spray pattern. Since the dispersion is almost negligible over short distances, it maintains momentum and force. Fan and full-cone sprays, on the other hand, lose a large amount of their original momentum and force because the sprays disperse so much. This was demonstrated in refurbishing tests. Compared to the fan spray, the straight jet cuts quicker and more effectively at a given pressure. However, the jet has such a small radius that it is unable to cover the entire area to be cut. In order to use the nozzle for this system, it would have to be rotated through a small angle to cut the entire stem. This is not possible with the SPGU's refurbishing system, because it slides along tracks that do not allow rotation. Devising a system to allow rotation of the cutting nozzle would require more time, and probably some moving mechanical parts. To maintain the simplicity of the sliding refurbishing

system, it was necessary to use the fan nozzle, which could cut the entire width of the stem from a stationary position. In the prototype testing that was described previously, it was determined that ten pounds of force would be required to break the radish stem. This implies that, if the area of the radish were less than 1/10 of an inch, the pressure required would be approximately 100 psi. By the use of the momentum equation and conservation of mass, it was also determined that the pressure required would equal the dynamic pressure at the outlet of the cutting nozzle.

Seed Port Cleaning Nozzle. After the plant is cut at the SPGU surface, the root mass, stem, and seed holder that remains within the port may be blown out by spraying a water jet directly down the port. Since the entire port must be cleared, a full flow field would be required. Again, volume flow must be kept minimal in order to keep the refurbishing unit (nozzles) small and testable. Due to the high water pressures associated with the refurbishing nozzles, the nozzle flow is forced to spread outward as soon as it leaves the orifice. Therefore, the spray from a full-cone nozzle would spread out more than desired, and it would not be concentrated enough to successfully blow the material out of the port. Not only did it lose force by spreading out, but some of the flow missed the port opening, creating an uncontrollably wet environment. The decision was then made to use a straight jet. The flow from the straight jet nozzle has a 0° angle of departure from the 3/64 inch diameter orifice. Although it still spreads out slightly due to the high pressure, the entire flow enters the port opening, and hits the material with enough accuracy and concentration to completely envelop and dislodge the material. Due to the success of the straight jet in cleaning the seed holder ports, it was included in the refurbishing system of the SPGU.

Overall SPGU

Fabrication. The fabrication of the SPGU and its subsystems was a long and laborious process. The plant containment vessel was the first part built; later came the subsystems to power the vessel. An eight inch by eight inch box was first

constructed, milling all four sides together to be sure each side was identical. Then, the four sides were assembled using a Methyl-Ethyl-Ketone-based glue while being held by a framing vise. The top part that actually holds the plants in position was the next part constructed. The top plates were first milled square within a few thousandths of an inch. Then, over 900 holes were drilled in the perforated plate to allow for the proper air flow area. The two plates were then clamped together, and the holes for the seed holding ports were drilled. The pieces separating the two plates (spacers) were milled and glued to the perforated plate. Silicon was used on the spacers so that the parts could be disassembled at a later date, if necessary. The screw holes were drilled through the plates and spacers while they were held together by clamps. In order to locate the holes on the box, the perforated plate was clamped to the box, then drilled with a smaller bit so that the holes in the box could be tapped. After tapping the holes, the triangular pieces were milled at the appropriate angle. Only two could be milled simultaneously due to the difficulty in mounting a triangular piece to the mill table. The lengths of the triangular blocks were critical because they needed to fit snugly inside the box. The triangular pieces were glued in place using silicon to facilitate removal and replacement, if necessary. The vacuum tubes were slotted using the milling machine, with a solid dowel inside the tubes, in order to support the walls during the process. Because the tubes did not fit perfectly, they were laminated to the bottom of the box using silicon in order to fill in any holes. The rest of the piping was assembled using PVC cement. Holes were then drilled and tapped for the air inlets, and the deflection plates were manufactured on the lathe.

The nutrient delivery system was the next part to be constructed. The nozzles were first inserted through holes in the top plates of the SPGU. The holes were drilled so that the nozzles and hose would be held snugly. Once the amount of water and the supply pressure were known, a search for a suitable pump was conducted. Unfortunately, the prices for such a pump were over the allowed budget; thus, it was necessary to search for existing equipment. A one-half horse-power variable speed motor and direct displacement gear pump were found. The motor and pump were

mounted to a board and piped to allow the extra water to recirculate to a reservoir. Standard irrigation fittings were used for the nozzles. The motor was not strong enough to overcome the friction in the pump, and could not build up the required pressure for the nozzles. Therefore, a belt with pulleys to reduce the load on the motor was tried, but showed no significant improvement. Because the specifications in the Grainger Catalog indicated less horsepower should be needed by the pump, a decision was made to try a three-phase, one-third horse-power motor. This motor worked well. The pump was piped to the wet-dry vacuum which was serving as a reservoir. Because the irrigation fittings leaked, new pipe fittings were improvised. To keep the nozzles from clogging, a filter was connected directly ahead of them.

Because a pump that is able to deliver less than a gallon a minute at a pressure which exceeds 100 psi is extremely expensive, an alternate way of delivering the cutting fluid was considered. Using a steel scuba tank mounted on a stand, piping was added along with a regulator and nitrogen tank. Valves were then placed appropriately to control and release the pressure as desired, and to facilitate the filling of the scuba tank with the cutting fluid. The nozzle holder was constructed by milling, drilling, and tapping an aluminum block. Tracks were then milled into the top plate of the SPGU to hold the nozzle holder in place during refurbishing.

Operation. The basic operation of the SPGU is very similar to that of the proposed PGU. The PGU would require a complete sensor based closed-loop control system. Operation would include at least four distinct modes, each for a specific period of crop maturation. The SPGU employs simple control hardware that allows continuous cycling of the components with the capability of being upgraded with sensors and a computer.

The nutrient delivery system is controlled with a digital interval timer. The timer opens and closes two circuits simultaneously every 15 minutes. One is a 24 volt control circuit that includes a fixed interval off delay and two relays. The other circuit is a 110

volt line with a rheostat. When the timer closes the circuits, the 24 volt control line closes a 110 volt relay, which then closes a three phase relay, that switches on the nutrient delivery pump. The 110 volt circuit powers the vacuum and is adjusted with the rheostat. When the timer opens the circuits, the vacuum is turned off while the off delay keeps the pump operating for an additional 60 seconds. The grow light operates continuously.

This mode of operation, delayed switching of the nutrient pump, was chosen to prevent drying of the roots. Switching both components off simultaneously would accomplish the same thing but would not allow the capability of delayed switching required for testing. In microgravity, delayed switching of the vacuum may be more desirable.

RESULTS FROM TESTS

Prototype Tests

The results of the tests and the methods that were used are in the following sections.

Opposing Gravity. The opposing gravity test was primarily to observe the delivery and recovery of the nutrient solution in an opposing gravity field. It was performed to confirm that the SPGU would work in a microgravity situation. The SPGU was oriented such that the nutrient solution entered from a lower potential energy state, with respect to gravity, than from where it was recovered. In other words, it was rotated such that the nutrient spray entered from the bottom, and the vacuum pulled it out of the top. In this orientation, the solution accumulated until an equilibrium water depth of about 1.5 inches was obtained. In this case, the vacuum was run at about 70% of the vacuum's maximum motor speed. As the vacuum's power was increased to 100%, the equilibrium water height decreased to approximately 0.5 inches. These figures correspond to the standard SPGU. If the SPGU is altered, by drilling more holes from

the top surface down to the root chamber, more air is pulled through the SPGU and into the nutrient recovery vacuum. In this case, with an increased air flow into the vacuum, there is no accumulation of solution within the SPGU. This test showed that in any SPGU orientation, the accumulation of nutrient solution can be monitored and varied according to the vacuum power and the air input.

Refurbishing. Because of replanting and seed holder changes, germinating seeds never had enough maturation time to grow above the SPGU surface. Thus, refurbishing could not be performed on the actual unit. A prototype SPGU surface was developed to perform refurbishing tests. The prototype surface has three rows of seed holder ports, with eleven ports in each row. Refurbishing tracks were milled exactly as in the actual SPGU. The main purpose of this refurbishing plate was to place mature radishes (or other small crops) into the port, and cut them with the refurbishing nozzles. It would not be necessary to wait for the plants to germinate and mature in this case. Because of the inability to find mature radishes with stems still attached, cutting tests were performed with celery. Celery has a very high percentage of cellulose, and is one of the strongest vegetable crops. Thus, it was hypothesized to be an optimal test for the refurbishing nozzles. At a water pressure of 500 psi, the fan nozzle was able to cut six celery pieces (1/4 inch diameter each) in approximately 5 seconds. With increased pressures and a more efficient nozzle system, the refurbishing time may possibly be further reduced.

Germination. The first function of the SPGU was to provide a location for seed germination. To test the capability of the SPGU as a seed germination location, 18 seeds were planted in a fashion previously described. After planting, the SPGU was turned on and allowed to operate continuously (see Overall SPGU Operation). Seed germination was monitored by periodic inspection. No seed viability tests were performed on the seeds selected for planting.

On the first planting trial, six seeds germinated within five days and began to grow. On the second trial eight seeds showed signs of germination and were allowed to grow for the remainder of the project.

Growth. Because of time constraints, no plants were grown to maturity in the SPGU. Also, the SPGU was designed as a germination location and does not allow easy transplantation of growing plants. In other words, the growth of plants in the SPGU is dependent on germination occurring in the SPGU.

CONCLUSION

Planting

At the outset of the project, it was decided to spend very little time and focus on the planting aspects of the SPGU for reasons previously described. However, more time than originally planned was spent on this. Although no thorough testing was conducted for the planting scheme, a feasible solution was developed after several time-consuming adaptations. Using the perforated plastic seed holder, the seed has the ability to absorb nutrient mist, remain in a fixed orientation, and grow under semi-normal conditions (except for the vibrations and noise produced by the pump and vacuum systems). Only time and further research can determine whether or not these factors will inhibit the growth of the plants. The SPGU root chamber and aeroponic system are foreseen to be very adaptable to other crops, especially root and tuber crops. If the root chamber was increased in height, and distance between seed holder ports was increased, it would be a suitable growth chamber for the potato. Potatoes need a force acting down on them, from the top, for proper growth. The vacuum of the SPGU pulls air and solution down through the chamber; thus, it would create a force on the top of the potato. This is not possible in the various growth systems being tested at KSC.

Opposing Gravity

The tests performed on the SPGU, with respect to nutrient delivery in microgravity, showed that a vacuum oriented nutrient solution recovery system could offer an alternative to current systems. Because the tests were performed under opposing gravity, it is conceivable that in microgravity, parameters such as vacuum pressures and flow rates could be reduced. Potential problems with separation of nutrient solution and vacuum fluid are foreseen.

Germination

The fact that seeds did germinate and began growth in the SPGU suggests that a nurturing environment does exist in the growth chamber. With the addition of sophisticated sensing and seed viability testing, the rate of germination could be improved.

Refurbishment

It has been shown that the concept of hydro-refurbishing offers a feasible solution to cleaning and harvesting a plant growth chamber. It was able to remove all of the plant biomass from the chamber completely. Although this process requires relatively high pressure (500 psi), it can easily be attained by the use of a pump or a pressurized vessel. This process will drastically reduce cleaning time, and can be easily automated. Optimization of the refurbishing system, such as better orientation of the nozzles, will reduce cleaning time even further. This type of system lends itself to easy integration into the SPGU, and eventually the PGU, without interfering with plant growth. With modifications to the track system, the hydro-refurbishing system may work with the porous tube and plate configurations currently being worked with at KSC.

REFERENCES

Bete Fog Nozzle, Inc. Company Catalog. January 1991.

Brown, Ronald (Shop Foreman). University of Florida. Department of Aerospace Engineering, Mechanics, and Engineering Science. Personal Interview.
15 February 1991.

Carroll, Bruce (Low Speed Aerodynamics). University of Florida. Department of Aerospace Engineering, Mechanics, and Engineering Science. Personal Interview.
10 February 1991.

Doddington, Harold (Instrumentation). University of Florida. Department of Aerospace Engineering, Mechanics, and Engineering Science. Personal Interview.
28 March 1991.

Frier, Raymond (Shop Machinist). University of Florida. Department of Aerospace Engineering, Mechanics, and Engineering Science. Personal Interview.
20 February 1991.

Grainger Catalog. January 1991.

Hirko, Robert (Instrumentation and Control Theory). University of Florida. Department of Aerospace Engineering, Mechanics, and Engineering Science. Personal Interview.
28 March 1991.

Jenkins, David (Mechanics of Materials). University of Florida. Department of Aerospace Engineering, Mechanics, and Engineering Science. Personal Interview.
20 February 1991.

Kurzweg, Ulrich H. (Fluid Dynamics). University of Florida. Department of Aerospace Engineering, Mechanics, and Engineering Science. Personal Interview.
12 February 1991.

Mei, Renwei (Fluid Dynamics). University of Florida. Department of Aerospace Engineering, Mechanics, and Engineering Science. Personal Interview.
28 January 1991.

2. Container and Receiving Mechanism (CARM)

Prepared by:
Robert Clement
Sofia Lopez

TABLE OF CONTENTS

Summary	42
Introduction	43
Specifications	44
Systems Investigated	45
L-channel	45
Plunger	46
Roller	46
Particles Transported	47
Large Particles	47
Small Particles	47
Description of the CARM	48
Cylinder	49
Bag Attachments	49
Closing Mechanisms Investigated	50
Testing procedure	53
Conclusion	55
References	56

SUMMARY

The Container and Receiving Mechanism (CARM) is a device designed to transport and store solid matter. CARM is a crucial interlink between the various compartments in the Biomass Management System (BMS). In a microgravity, environment containment is a problem because of the tendency of particulate matter to disperse randomly about the atmosphere.

A canister system does not currently exist in CLLSS. Any research and development will prove highly beneficial to the BMS. Last semester two approaches were examined to develop transport system. CARM could incorporate with either the pneumatic or magnetic belt ideas.

CARM consists of three separate components: the cylindrical container, the bag attachment, and an iris-type closing mechanism. The shape of the cylindrical container resembles a bank teller canister. A bag attached at one end of the container serves to contain and transfer the contents.

There are several problems addressed. The transfer of small particles (i.e. flour) presents certain problems. There should be no gap between the container and the destination unit. This is necessary to prevent any leakage. The transferring process will use pressure differences to transfer the contents of the bag to the processing unit. The pressures required for transfer are in the order of 1 to 2 atm. Because of this low pressure microgravity should not adversely affect the system. The CARM should in fact benefit from the lack of gravity.

INTRODUCTION

In a Closed Loop Life Support System (CLLSS) there is a need for the containment and storage of the edible biomass produced. The absence of a gravitational force necessitates the containment of all particles. In a microgravity environment loose particles pose a unique problem since they disperse throughout the surrounding compartment. As a solution, a Container And Receiving Mechanism (CARM) that is multifunctional has been proposed: its primary function is the sealed transport and transfer of food to a processing unit, the secondary function is the storage of food until further processing. CARM's use should not be limited to the transfer of inedible biomass between the Plant Growth Unit and Food Management. It has numerous applications in the movement of mass between all compartments in a CLLSS.

SPECIFICATIONS

The design specifications for the container and receiving mechanism (CARM) are as follows:

1. The sealed container will have zero loss of matter to the surroundings.
2. The residue left in the container should not exceed 0.1%.
3. The loss of matter during exchange should not exceed 0.1%.
4. The container should be of optimum shape and size to maximize ease and efficiency during transport.
5. The container is intended for transport of a meal-size portion of edible biomass (i.e. potatoes) for a crew of four.
6. The volume should not exceed 600 cubic inches and the weight should not be greater than 5 lbs.
7. The transport of solids ranging in size from a upper limit of 3.8 inches in diameter (i.e. potato) to a lower limit of .005 inches (i.e. sugar granule).
8. For testing, the inside of the container should be visible from all directions to monitor the internal behavior of the system.
9. Minimal human interaction defined by attaching and detaching of the container which should require less than 1 minute per use.
10. A maintenance schedule will have to be established based upon the components used in the unit.
11. The unit should consist of a minimal number of parts.
12. Repair will be done by the crew with on board spare parts.
13. The reliability of the unit should be on the order of 1,500 cycles per year before repair is needed. The cycle was determined considering the attachment, transfer, and detachment of the unit.
14. The unit should be adaptable to different receptacles and Food Management processors.
15. The ease of cleaning should be a consideration in choosing the shape of the unit.

SYSTEMS INVESTIGATED

Several different transfer systems were evaluated before final selection of the CARM. These included an L-channel device, a plunger system, and a roller method.

L-channel

The L-channel device consisted of a cylindrical canister and an L-shaped channel (Fig. 2.1). The canister fits into the smaller leg of the channel. A piston at one end of the canister forces the contents out into the longer leg of the channel. The contents are then blown down the longer leg into a receptacle. Several factors made this system not feasible. It required an elaborate setup which would involve more human interaction than desired. The bulky nature of the channel hindered its adaptability for other uses. The fan to propel the contents also posed problems when dealing with small particles of food. The fan would blow the contents in a random fashion decreasing control of the transfer process.

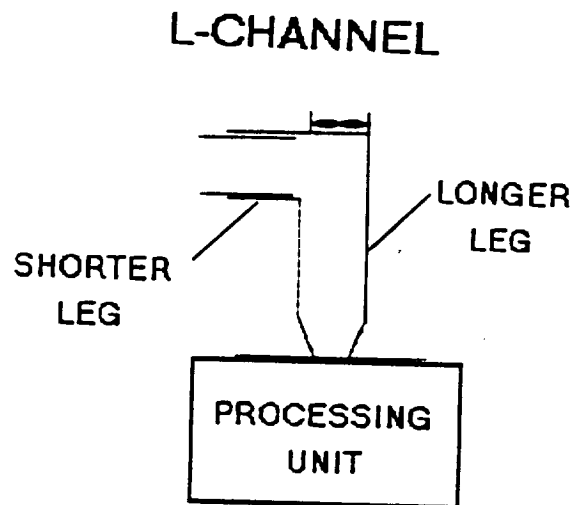

Figure 2.1 L-Channel System.

Plunger

The plunger system involved a canister with a removal mechanism at one end (Fig. 2.2). This system is modeled after a syringe. The removal mechanism was operated manually to expel the contents. This system poses a problem of accumulating residue within the container and at the plunger-container interface (Fig. 2.2). This leads to the possibility of growth of microorganisms. The cleaning of this unit would require that the system be disassembled allowing particles to escape into the surroundings.

PLUNGER SYSTEM

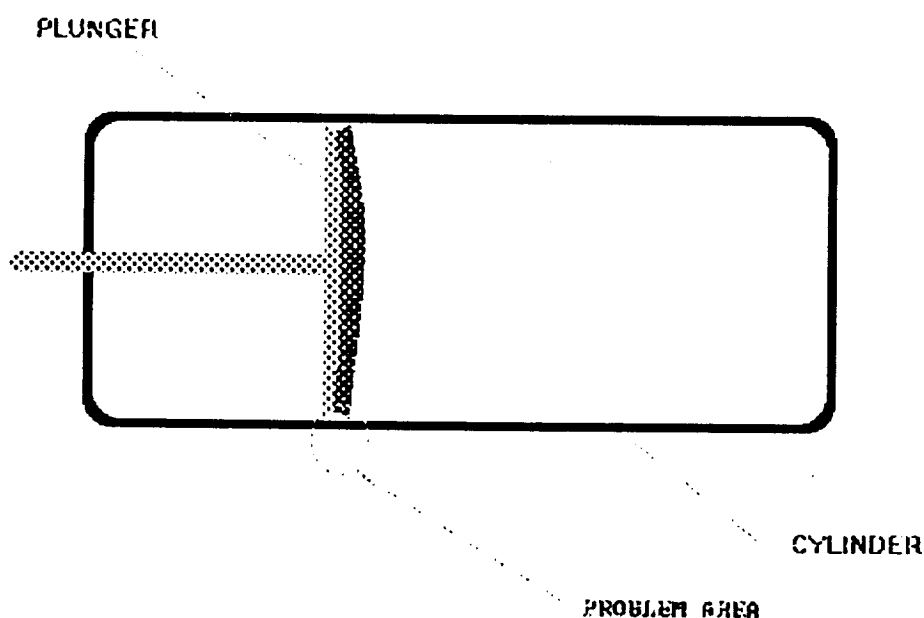

Figure 2.2 Plunger System

Roller

The roller system consisted of a flexible tube and two rollers that serve to press out the contents (Fig. 2.3). This operates in much the same fashion as squeezing toothpaste out of the tube. Experimentation with this type of system proved that the

roller method would not press out all of the small particle contents. A layer of material was left in the tube. This method also had the possibility of damaging food contents and puncturing the tube.

ROLLER METHOD

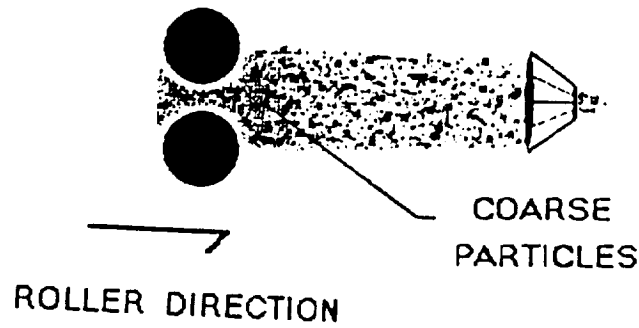

Figure 2.3 Roller Method

PARTICLES TRANSPORTED

The initial use of the CARM involved transport of a meal-size portion of edible biomass for a crew of four. It was not intended as a bulk transfer unit. CARM is for transfer within Food Management.

Large Particles

Large particles can be defined as being greater than a coarse grain of flour (50 micrometers). Large particles do not pose a problem during transfer. Edible biomass, such as potatoes or radishes, is of sufficient size that dispersal during transfer or residue after transfer is not a factor. The large particles are solid matter that do not involve particulates dispersing randomly.

Small Particles

Small particles can be defined as less than 50 micrometers. Small particles pose a

problem in a microgravity environment. Containment is necessary to insure that the particles do not disperse randomly about. This containment can best be achieved by using a bag during transport.

DESCRIPTION OF CARM

After examining the different options, a final selection for a transfer mechanism was made. The CARM system chosen consists of a hard shell cylinder, a bag attachment, and an interlocking mechanism (Fig. 2.4).

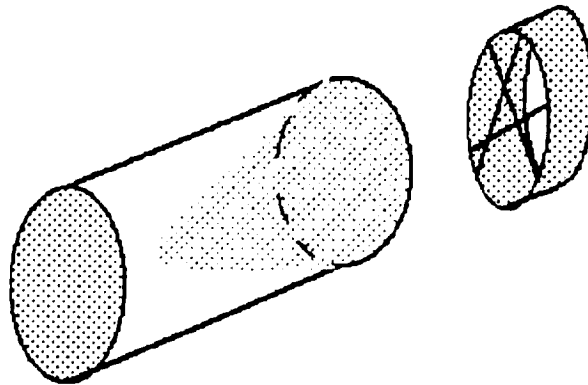

Figure 2.4 CARM Components

Cylinder

A cylindrical shape has several advantages: ease of transport, cleaning, and storage. This shape also adapts itself to the transport mechanism presented last semester in EGM 4000. For testing purposes a clear cylinder was chosen so that the internal environment could be observed. The hard shell construction allows air pressure to be used to move the contents. The 4" diameter by a 12" length dimension reflects the CARM's intended use in transporting a meal-size portion of edible biomass for a crew of four.

The opening of the cylinder should be the same size as the container to prevent a backup of the contents at the opening. Clear polyvinyl chloride (PVC) is the ideal material due to its ease of machining. This material is available at \$300/10ft for a 3" diameter. Due to the cost of clear PVC, plexiglass was chosen to construct the CARM.

Bag Attachment

A bag lining was needed to contain small particles (Fig. 2.5). The contents of the bag were expelled by using air pressure within the cylinder to force the bag inside out. There were two important criteria for selection of the bag material: 1) flexibility for ease of transfer and 2) durability for a high number of cycles (1,500 cycles/year).

BAG ATTACHMENT

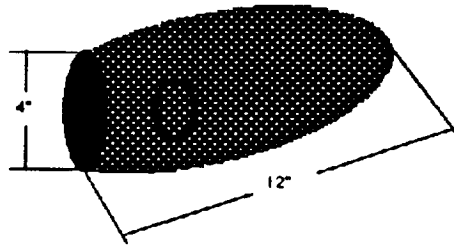

Figure 2.5 Bag Attachment for small particle containment.

The shape of the bag was determined through testing. Rectangular bags were not feasible since during transfer the contents tend to remain at the bottom of the bag and are not able to pass through the opening. This was corrected by rounding the ends of the bag.

Several different options were considered for the bag's material. Flexiglass is an acrylic sheeting that was heat sealed to construct bags. The Flexiglass was too stiff and did not turn inside out. A polyurethane sheeting was also heat sealed to create bags. The polyurethane was more flexible than the Flexiglass but did not easily turn inside out. Another option investigated was intravenous fluid (IV) bags made of flexible PVC. This was considered due to the durability and toughness of the material. A factor that affected the flexibility of the above materials was their thickness.

Closing Mechanisms Investigated

A vital component of the CARM is the closing of the bag attachment. This prevents particles from dispersing randomly during transport or transfer. Several different closing mechanisms were examined: a sphincter, an inflatable seal, a hinge, and an iris.

Sphincter. Sphincters are widely used in the medical field. They are inflatable prosthetic seals designed for patients with incontinence. Using this principle sphincters were explored as a possible closing mechanism for the bag. The problem encountered was that industry does not manufacture a 4" sphincter. Due to the molding and fabricating process of any sphincter manufacturing one was not an option.

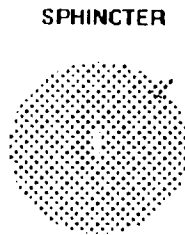

Figure 2.6 Sphincter.

Inflatable Seal. Using the same principle as sphincters, inflatable seals were investigated as a possible solution. Custom-made inflatable seals were promising. However, the problem was the inability of the seal to expand radially inward in such a small diameter. The seals are not intended to stretch, any expansion is built into the seal.

Hinge. A hinge type mechanism was examined (Fig. 2.7). This consisted of two flexible metal bars joined at the ends. The problem with this method was that the rapid opening or closing of the mechanism created turbulent flow. Upon opening and closing the hinge mechanism lost contents.

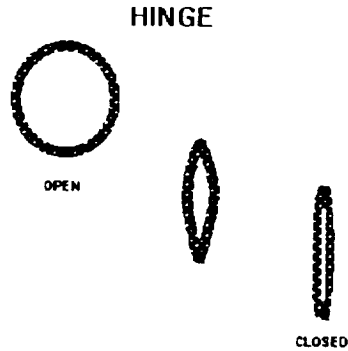

Figure 2.7 Hinge Mechanism.

Iris. The iris closing mechanism was modeled after the shutter of a photographic camera (Fig. 2.8). The problems encountered with this system included an insufficiently tight seal which allowed leakage of small particles. A modification of the iris is the snare end effector in the mechanical arm of the shuttle. This system consists of three wires arranged equidistant from each other on an outer ring attached transversely to an inner ring (Fig. 2.9). The wires system works by rotating the outer ring while keeping the inner fixed. This twists the bag closed. This system has proved effective in containing small particles such as flour.

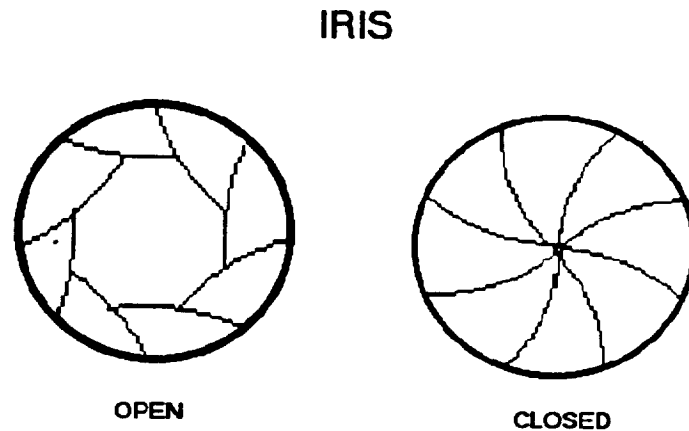

Figure 2.8 Iris Closing Mechanism.

CLOSING MECHANISM

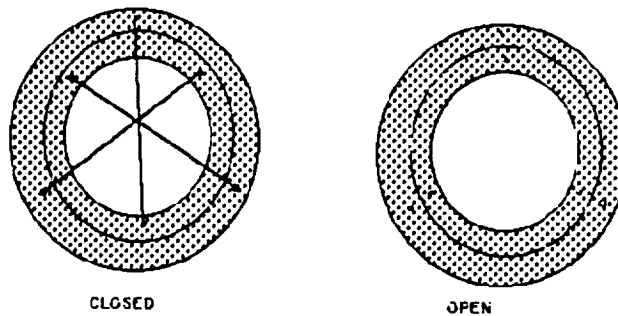

Figure 2.9 Closing Mechanism

TESTING PROCEDURE

In order to substantiate the CARM working in a microgravity environment each test was run at multiple orientations. The use of multiple orientations assumes that if the CARM can work in opposition to gravity, then a microgravity environment will not adversely effect the CARM's performance. Testing of the CARM involved two separate procedures. The first experiment involved the complete sealing of a CARM unit without loss to the surroundings. The second more challenging experiment involved minimizing the loss to less than 1% during transfer from one CARM to another.

The first step was eliminating loss of the contents during transport from one area to another. The zero loss seal of the CARM unit was accomplished by using the modified iris design. Complete sealing was necessary to enable the CARM to be used as a storage unit. Without a tight closure to prevent the passage of air or moisture the food contents would spoil.

The next more complicated task involved minimizing loss during transfer. During transfer of the inedible biomass from one CARM to another there are two specific types of loss: 1) the loss introduced from the junction of one CARM with the other and 2) the loss introduced from the residue left on the bag.

Testing of the CARM prototype showed that the device successfully contained and transported materials as indicated in the specifications. Complete sealing during transport was achieved. During transfer it was observed that there was no loss to the surroundings.

CONCLUSION

CARM could prove a beneficial addition for long term space missions. Its use should not be limited to transport and storage of inedible biomass. With the development of CARM units in a variety of sizes, CARM has limitless possibilities. It can be used in Planting and Harvesting to deliver seeds and remove harvested crops. CARM's applications extend to Resource Recovery where it can be used between bioreactors. CARM could also be used to transport from the crew compartment throughout the BMS. Fig. 2.10 illustrates operation of the CARM for biomass transfer.

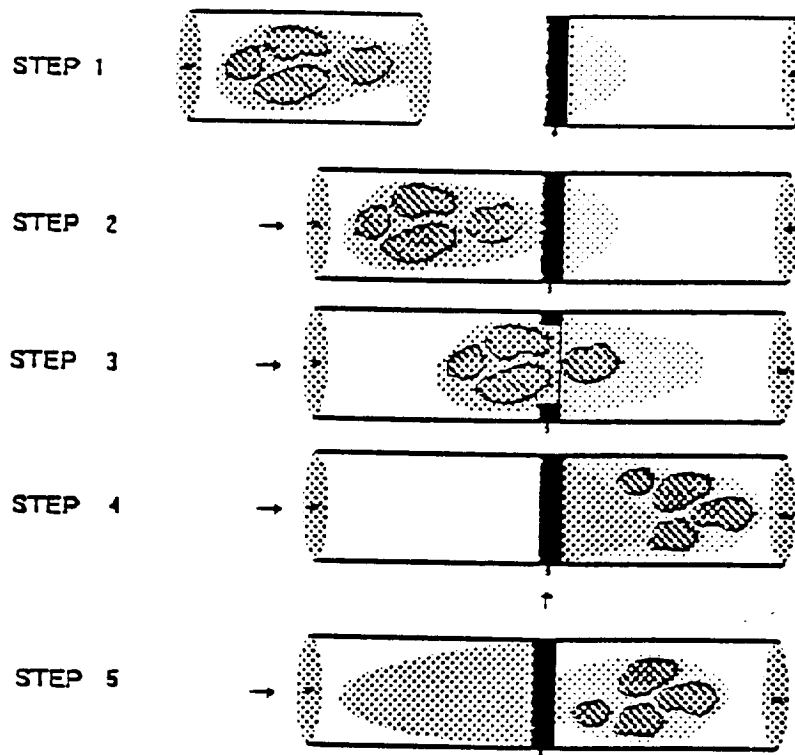

Fig. 2.10. CARM operation: The CARM with the biomass is brought up to the other unit (Step 1). The bag is opened and air is pumped into the cylinder at its end to move the biomass (Step 2). Biomass transfer begins from one bag to the other (Step 3). Air is pumped at the interface of the locking mechanism to complete transfer (Step 4). Air is evacuated through the end of the CARM to force the bag back to the original position (Step 5). Transfer is completed.

REFERENCES

Hill, Tom. Seal Master Corporation. Kent, Ohio. Correspondence.

Rockwell International. Press Information. Space Shuttle Transportation Systems. March 1982.

3. An Air Curtain System for Fugitive Particle Control

Prepared by:
Andrew Bream
Isabel Chong
Pablo Gersberg

TABLE OF CONTENTS

Summary	59
Introduction	60
Specifications	61
Systems Investigated	62
Glove Barrier	62
Sliding Barrier	63
Air Curtains	63
Multiple Air Curtain	63
Vortical Air Curtain	64
Expanded Air Curtain	65
Single Air Curtain	66
System Proposed	66
Reasons for Selection	67
Design	67
Components	69
Centrifugal Blowers	69
Plenum Chamber	69
Nozzle	69
Working Area	69
Air Recycling Device	70
Vacuum	70
Fabrication	70
Testing	71
Conclusion	72
Recommendations	72
Appendix A	73
Appendix B	75
References	79

SUMMARY

In a microgravity environment fugitive particles from foodstuff, for example, can migrate and lodge on surfaces. Control of such debris plays an important role in the health of the crew and the functioning of equipment. Different systems to control fugitive particles were explored by this team. Of all the systems investigated, an air curtain was found to be the most promising solution for particle control. Air flow characteristics of different configurations were investigated and a system consisting of a single air curtain was selected for further development. A prototype unit was built and tested. The prototype consisted of two centrifugal blowers which forced air through a plenum chamber and out a nozzle. The air from the nozzle functioned as a barrier to fugitive particles, while allowing the user fast and convenient access to the interior of the unit. The air from the nozzle was collected at the base of the unit by a suction mechanism, filtered, and recycled to the blower intake. A user activated vacuum device was added as an integral part of the unit to facilitate cleaning. The unit was found to successfully contain or expel low density particles (i.e. bread crumbs) traveling at 218 ft/min (1.11 m/s) perpendicular to the curtain. The results suggest that the single air curtain configuration will be useful in containing fugitive particles from escaping or entering a work area in a microgravity environment. Some of the applications of an air curtain device for particle control may be: a food preparation work space, an automated transfer mechanism of the Container And Receiving Mechanism (CARM), and an equipment maintenance work area.

INTRODUCTION

On manned long term space missions, fugitive particle control plays an important role in maintaining the crew's health and safety as well as the proper operation of equipment. The principal sources that cause particle control problems in the spacecraft are the crew members (finger nail clippings, hair); food (liquid and solid spills, crumbs); maintenance (loose parts, leaks); and payloads (animals, chemicals). Microgravity causes this debris to migrate and lodge on surfaces. Inhalation of these particles by the crew and their accumulation on equipment could prove harmful to the mission. Thus the greatest practical precautions should be taken to ensure freedom from debris and contamination within the spacecraft.

One possible solution for fugitive particle control is to enclose the source of the debris by a wall. Access to the source (i.e. payload) can be accomplished through arm insertion ports. Another solution is an air curtain. An air curtain jets a continual barrier of high velocity air--keeping air-borne particles from escaping or entering specific regions. Many of the advantages and disadvantages of each system were explored in order to focus on the most viable solution.

This report will describe specifications for particle containment, the different systems explored, a physical description of a particular air curtain device, and results obtained. Also presented are recommendations for future development and implementation of air curtain technology in the Biomass Management System.

SPECIFICATIONS

The following are specifications for general fugitive particle control (FPC) devices. Additional specifications for microgravity use are presented in Appendix B.

- Smooth and plain surfaces, that are easy to clean, should be used when possible for the work stations.
- Light level and intensity should be sufficient to allow the crew members to perform their visual tasks efficiently, causing no glare on the surfaces.
- All necessary materials should be placed within easy reach of the work area.
- Fugitive particle devices in general shall have the capability for the retention, collection and disposal of debris, odors, particulate matter, and liquid from the work station atmosphere.
- FPC units should have facilities for securing objects inside the unit.
- The FPC device shall require minimum preparation for its utilization and clean-up.
- Cleaning chemicals shall be low sudsing, safe for use in an enclosed environment, compatible with waste disposal systems, and shall not damage the surface being cleaned.
- If a vacuum cleaner system is used for particle control, the system shall provide adequate suction capability for the collection and retention of both wet and dry particulate matter and of liquids.
- If filters are used, these should be readily accessible for cleaning and replacement without disturbing the collected material.

SYSTEMS INVESTIGATED

In an attempt to meet the specifications given, this team designed several systems which would control fugitive particles in a microgravity environment. Below are descriptions of the units.

Glove Barrier

The glove barrier is similar to glove boxes used in laboratories. It consists of a clear, plastic box with glove ports as shown in Fig. 3.1. Elbow length or shoulder length gloves can be used. The number of ports is dependent on the maximum number of people who will be using it simultaneously. The advantages are that there is no leakage while the box is closed and that these devices are currently available. The disadvantages of this barrier are limited maneuverability and restricted entry and exit of items. All materials and utensils should be inside the box before any work is begun or may be entered through special mechanisms.

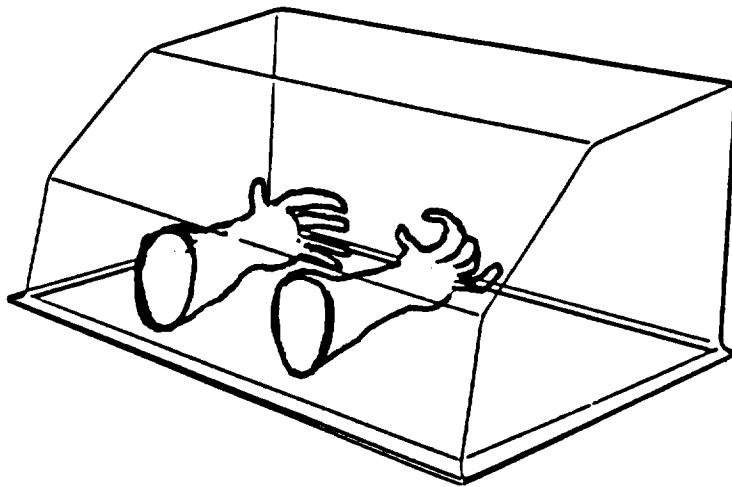

Figure 3.1. Glove Barrier

Sliding Barrier

This mechanism, a modification of the glove box design, consists of a box with sliding apertures for arm access as shown in Fig. 3.2. The sliding barrier offers the possibility of full containment and good mobility with simple physical means. The disadvantages are similar to those encountered in the glove box design. An added disadvantage is the necessity of several moving parts, increasing the likelihood of failure.

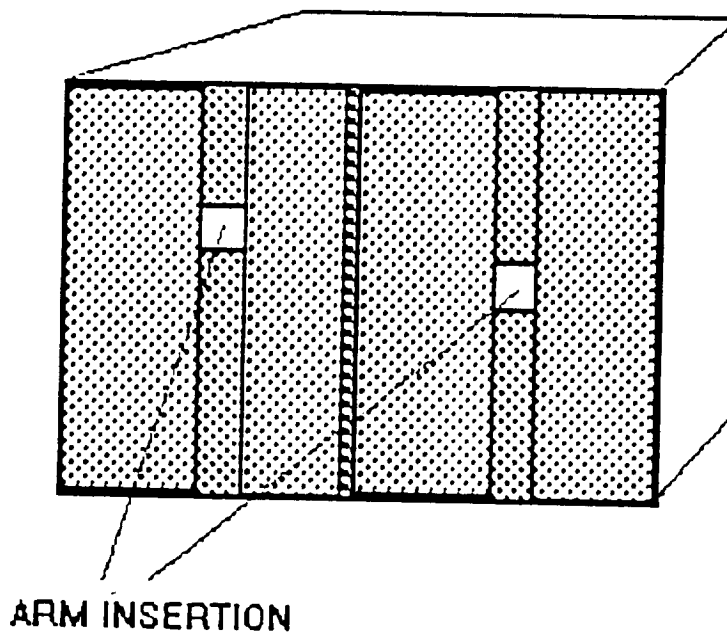

Figure 3.2. Sliding Barrier

Air Curtains

The following devices utilize air curtain technology. This technology utilizes air moving equipment to control fugitive particles.

Multiple Air Curtain. The multiple air curtain utilizes two or more two-dimensional sheets of air. One configuration consists of two independent, staggered, vertical curtains--one going up and one going down (Fig. 3.3). In this design, the stagnation points caused by the user's arm in each curtain are on opposite sides of the arm.

This decreases the possibility of a particle escaping through the stagnation points. The primary flaw of this design is that a fugitive particle which gets through the first curtain may have to travel the length of the second curtain before it is captured.

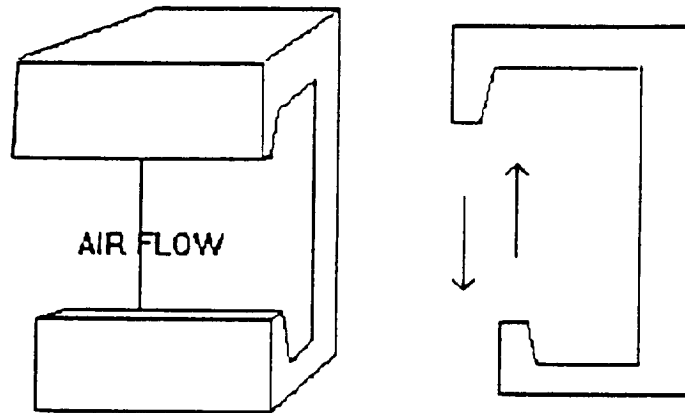

Figure 3.3 Multiple Air Curtain with parallel flows.

Vortical Air Curtain. Natural vortex air flows such as tornados and waterspouts were the basis for the following design. Air flow in a spiral vortex surrounds the area inside the vortex with a barrier on all sides, excluding the two ends of the vortex (Fig. 3.4). Because of the spiral pattern of the flow, the central axis of the vortex will have minimal air movement, such as the eye of a hurricane, and can be used as a work space. Any fugitive particles escaping from the work space will be swept up by the vortex flow. Another consequence of a vortex flow is that air pressure is lower in the center of the vortex, like the inside of a tornado. If the vortex flows toward the back of a work chamber, air will flow from the cabin, at higher pressure, into the work area and out the back. The flow inside the work space would keep fugitive particles from escaping into the cabin. One advantage of the vortical curtain is that there would be easy access to the work area and particles are constantly removed. A disadvantage of this design is that there would only be a thin, long work space available. In addition, the energy required to maintain the vortex flow may be great, in comparison to the other designs proposed.

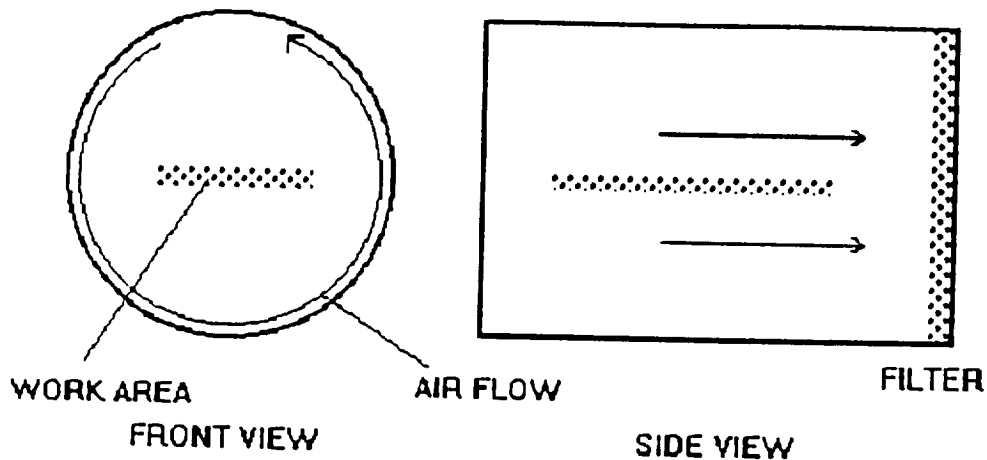

Figure 3.4. Vortical Air Curtain.

Expanded Air Curtain. The expanded curtain is created by blowing a volume of air onto the top of the work area (Fig. 3.5). One of the advantages of this unit is that there is no accumulation of debris because the ambient air is constantly being cleared. Another advantage is that the force of the air flow may keep materials, such as bread slices, pinned onto the work surface. Thus, other means of restraint may not be necessary. The disadvantage of this type of curtain is that it may start removing particles from the material being worked with, which may not always be desirable.

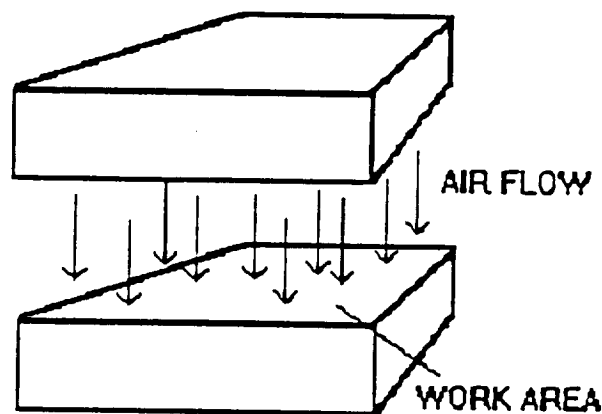

Figure 3.5. Expanded Air Curtain.

Single Air Curtain. This device (Fig. 3.6) consists of only one sheet of air forced through a nozzle. The volume of air can be collected and recirculated after filtering. One advantage of this design is that the user can operate the unit easily, yet particles are kept from entering or exiting the work area. This system also has the advantages that there is low air disturbance in the unit and it is a simple design. One disadvantage of this system is that stagnation points are formed by the user's arm in the air curtain.

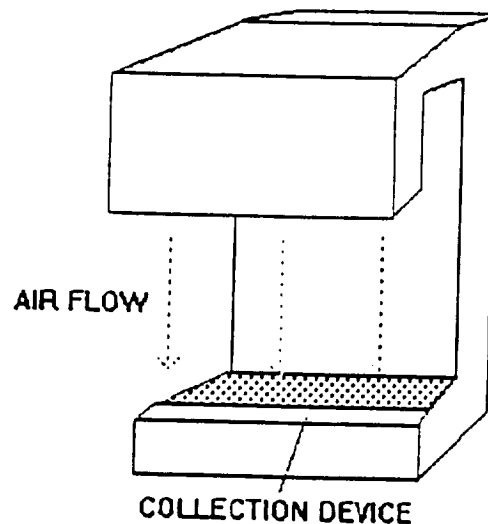

Figure 3.6. Single Air Curtain.

SYSTEM PROPOSED

Investigation of the several FPC devices showed that different arrangements could be useful for different tasks. For example, an expanded air curtain would seem promising for gaseous substance containment, while the single air curtain seems best suited for food preparation. This group selected a single air curtain for further investigation.

Reasons For Selection

Both physical barriers and the air curtains seem to be able to control fugitive particles. Glove boxes are currently used in industry (for medical research) and could easily be

implemented for long term mission use. The sliding wall system seemed to be a complex modification of a glove box. Both these systems were ruled out for further research because of their current availability, restricted arm motion, and restricted access to the work area. On the other hand, an air barrier allows freedom of movement and easy access. For these reasons, this type of fugitive particle device was chosen for further development.

Design

The final design had to meet the specifications stated for an FPC device. The main concern of this team was the effect of the arms through the air curtain, since it was suspected that this could disrupt the flow of air. In order to investigate the properties of air curtains, two nozzles attached to blowers were constructed. The nozzles had adjustable widths in order to determine the optimal air curtain width. Velocities of the air flow were measured at different locations to determine the optimal height of the curtain. The results are shown in Appendix A. To prevent debris from escaping or entering through the stagnation point created by the flow around the user's arms, a suction accessory was integrated at the bottom of the FPC unit (Fig 3.7).

The blowers and motor, which generate the air curtain, were installed behind the unit to allow frontal visibility. The sides and top are made of clear plexiglass to allow visibility into the device. To preclude the necessity of air separators, a plenum chamber was incorporated in the design. The nozzle was lengthened to create a more laminar flow. A method was designed to recycle the air back to the intake of the blowers. This method took advantage of the suction created by the blowers. A filtering system was incorporated into the design. A detailed description of the components follows.

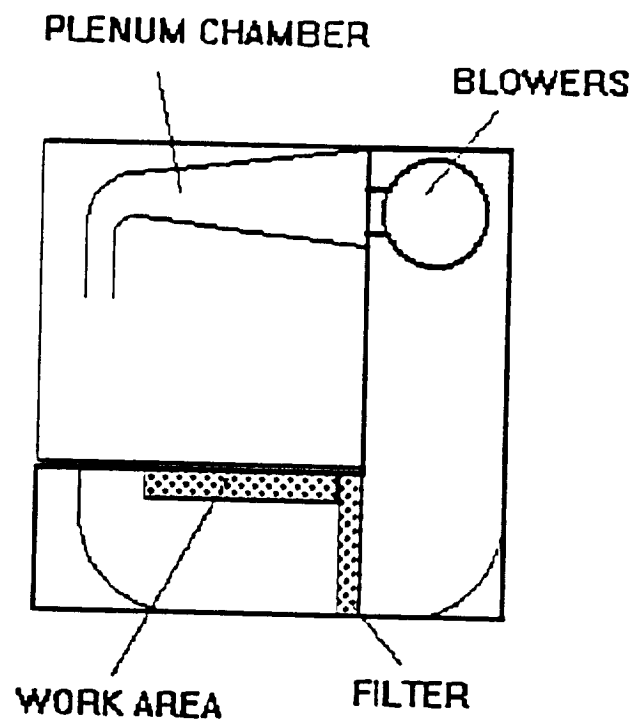
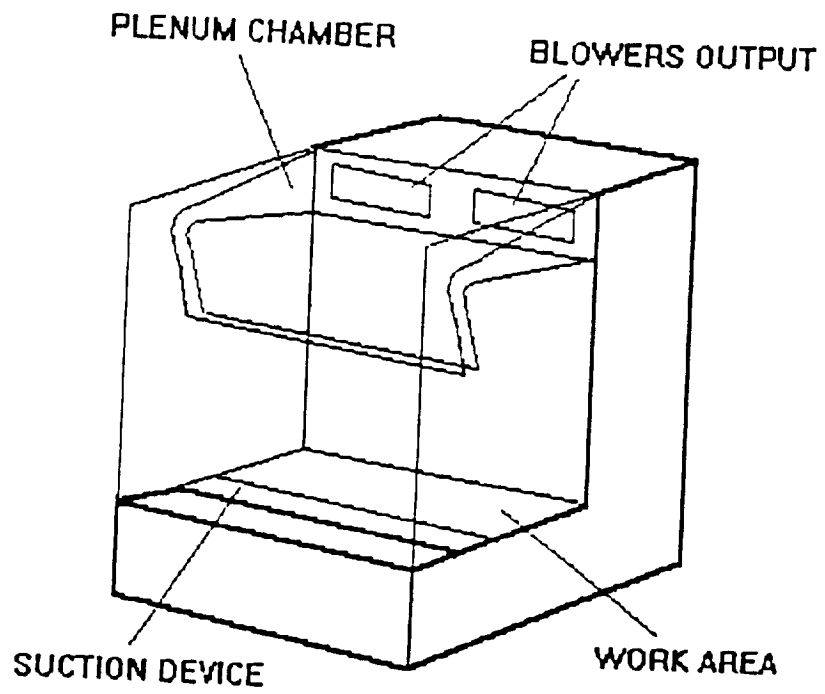

Figure 3.7. Proposed Air Curtain Device.

Components

The FPC unit designed contains the following parts:

1. Centrifugal blowers
2. Plenum chamber
3. Nozzle
4. Working area
5. Air recycling device
6. Vacuum

Centrifugal Blowers. The source of air is a power pack from a commercial air curtain system. The blowers are operated by a 1725 rpm 1/20 hp-Magnetek electric motor. The blowers are mounted on the back of the unit--blowing air into the plenum chamber at 330 cfm.

Plenum Chamber. The plenum chamber used in this unit was suggested by Mr. Sigmund Berlant, of Aresco & Augment Replacement parts. Most air curtains use flow dividers to separate the air emerging from the blowers. Use of the plenum chamber eliminates the need for dividers because it causes an increase in pressure which forces an even distribution of air out the nozzle.

Nozzle. The nozzle is an extension of the plenum chamber. The velocity of the air exiting the nozzle is dependent on the exit area of the nozzle. If the area is too large, the velocity of the curtain is decreased. See Appendix A for more information. This team decided to extend the nozzle 6 in from the plenum chamber to facilitate laminar flow. Air exits the nozzle at 400 cfm.

Working Area. The working area inside the unit is a 26 in x 12 in acrylic surface (a clear material was used in this prototype to allow visibility into the filter.) In this particular FPC unit, little disturbing air flow occurs across the working area.

Air Recycling Device. This component is placed at the front of the base of the unit to collect the air from the air curtain. It includes a suction created by the blower intake to aid in fugitive particle control. It also contains a standard removable filtering system to remove fugitive particles from the air before recycling.

Vacuum. This user activated device is a standard vacuum unit which allows collection of particles inside the work area for cleaning of the unit.

Fabrication

The unit was fabricated with commercially available materials. The blowers and motor were obtained from a commercial air curtain unit. The plenum chamber, sides, and work area were constructed of Plexiglass to facilitate visibility and testing. The structure was made of plywood to ease construction. The recycling device was constructed of sheet metal and plywood. The filter is from a standard air conditioner unit. The total cost of parts for the unit was \$ 315.00.

The blowers were mounted first onto a wooden structure. Openings for the blower outlets were then cut using a jigsaw. The Plexiglass sides were mounted afterward. The next step was to mold the plexiglass into the desired shape for the plenum chamber and nozzle. Different methods were tested to bend the Plexiglass. A blow-torch gave poor results due to the extreme heat produced. Using an oven for molding was not possible due to the size of the Plexiglass sheet. An industrial air blower was tried and the results were deemed acceptable for the project. Two of these sheets were molded and then mounted on the unit by using a methylethylketone-based glue. The suction device was constructed next.

The first design consisted of conventional air conditioning hook-up devices. Two 4-in diameter hoses were connected to the suction intake and back to the blowers. It was noticed that the output at the nozzle decreased from 400 cfm to 302 cfm. This was due to the fact that the blowers required a greater intake area. Friction along the 4-in

hoses compounded this loss. It was decided to rearrange the configuration of the suction device. An enlarged duct was constructed to recycle the air flow. This duct has an average cross-sectional area of 5 in x 26 in. The duct was constructed of plywood and sheet metal to reduce friction. The air flow stayed at the original level. This team proceeded to fabricate the filtering system. Conventional air conditioning filters were attached between the air intake and blowers. This filter seemed to work as desired. The work area was fabricated next. Plexiglass was again used to allow visibility into the filtering system.

Testing

For testing of the FPC device, small styrofoam particles of approximately 1/8 in (5 mm) diameter were put inside the unit. A hand-held fan placed inside the unit was used to disturb the particles. It was observed that the particles were successfully controlled by the device. These fugitive particles either (1) stayed in the working area or (2) were removed into the filtering system when attempting to escape. The nozzle output was 400 cfm at all points along its horizontal axis. The volume at the suction was 510 cfm. This volume increase was accomplished by increasing the area of the intake. The filtering system successfully trapped the fugitive particles for later disposal into the vacuum device.

CONCLUSION

Fugitive particle control is a major concern for long term space missions. It was found that a single air curtain system would be effective in preventing particles from entering or exiting working areas. The prototype unit successfully controlled fugitive particles. The unit was self supporting, i.e. the air curtain and the suction device were one single mechanism. The technology for the implementation of air curtains for fugitive particle control is readily available and units can be easily built to fit the desired function.

RECOMMENDATIONS

FPC devices may be necessary in a final CLLSS. These units could be used for containment of particles, gases, and microorganisms. Some systems which could benefit from air curtain devices are:

- Food preparation units
- Animal waste control
- Biological units
- Maintenance/repair units
- Container and Receiving Mechanisms (CARM)
- Electronic equipment
- Plant growth units (harvesting, refurbishing)

When designing a final fugitive particle device for long term space flights, consideration should be given to man-systems integration standards such as those listed in Appendix B.

APPENDIX A: Air Curtain Flow Determination

To aid in the determination of the optimal nozzle dimensions and configuration, experiments were performed utilizing two variable width nozzles attached to variable speed blowers. Following are graphical representations of data obtained.

NOTE: The vertical axis represents the height of the flow and the horizontal axis represents the distance from the nozzle exit (in cm).

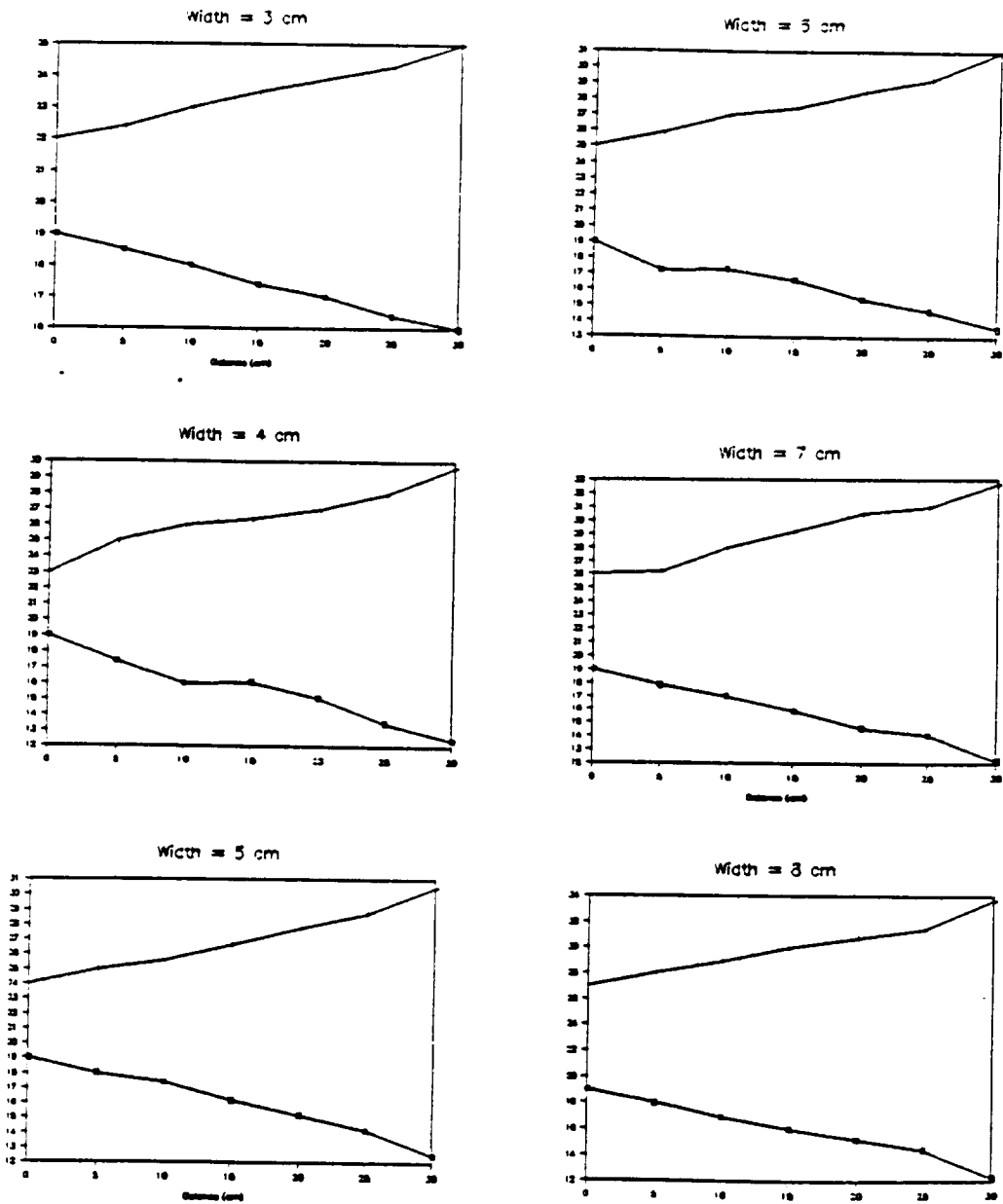

From the preceding data, the gradient of air flow expansion was determined for the different widths by the equation

$$(\text{max. height} - \text{nozzle height}) / \text{total distance} .$$

Also, the velocity drop was calculated. The data for this was calculated by using the formula

$$\text{velocity at max. distance} - \text{velocity at nozzle exit} .$$

WIDTH	GRADIENT	VELOCITY DROP
3 cm	0.133	100
4 cm	0.216	170
5 cm	0.207	200
6 cm	0.200	210
7 cm	0.217	240
8 cm	0.227	270

From these values, it was determined that the width of the nozzle which would satisfy the requirements for laminar flow was about 3 cm. The height of the air curtain was estimated to be 15 cm.

APPENDIX B: Implementation of Fugitive Particle Devices in a Microgravity Environment.

The following specifications should also be followed when designing FPC devices for microgravity use.

- Equipment must fit the user population. A single size device must accommodate all members of the crew.
- Neutral body posture (Fig. 3B.1) will be used in establishing a microgravity work space layout.
- The field of view for an observer is determined by head and eye movements (Fig. 3B.2).
- Foot and leg restraints, as well as restraints for tools and utensils (Fig. 3B.3) should be used for better reach performance, stability, and control. These restraints should not interfere with other tasks.
- FPC devices must help keep the respirable atmosphere contents at the levels shown in Table 3B.1.
- Visual cues should be utilized to define local verticals.
- All transparent surfaces shall be scratch/mar resistant, anti-fog and anti-icing where possible, and shatter resistant.
- Cleaning supplies should be available for the unit. The cleaning equipment shall be capable of sanitizing the unit; collecting and containing debris and odors; and washing of reusable utensils, serving equipment, and preparation equipment.

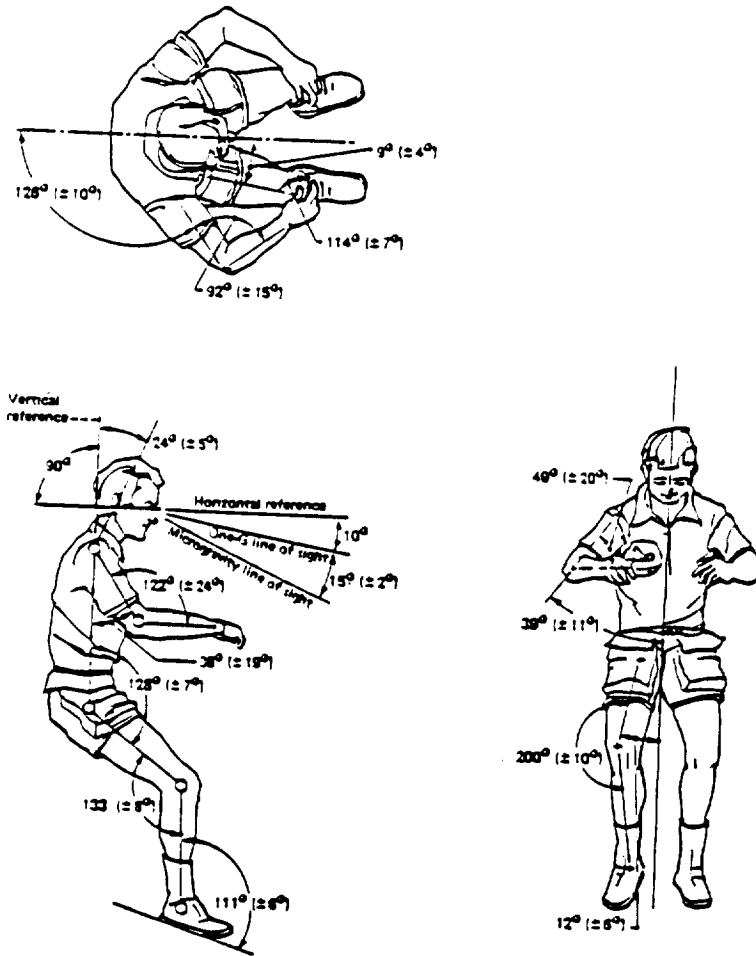

Figure 3B.1. Neutral Body Posture

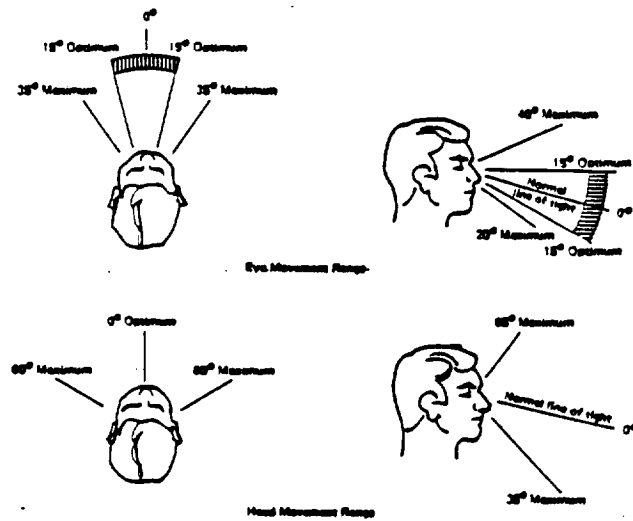
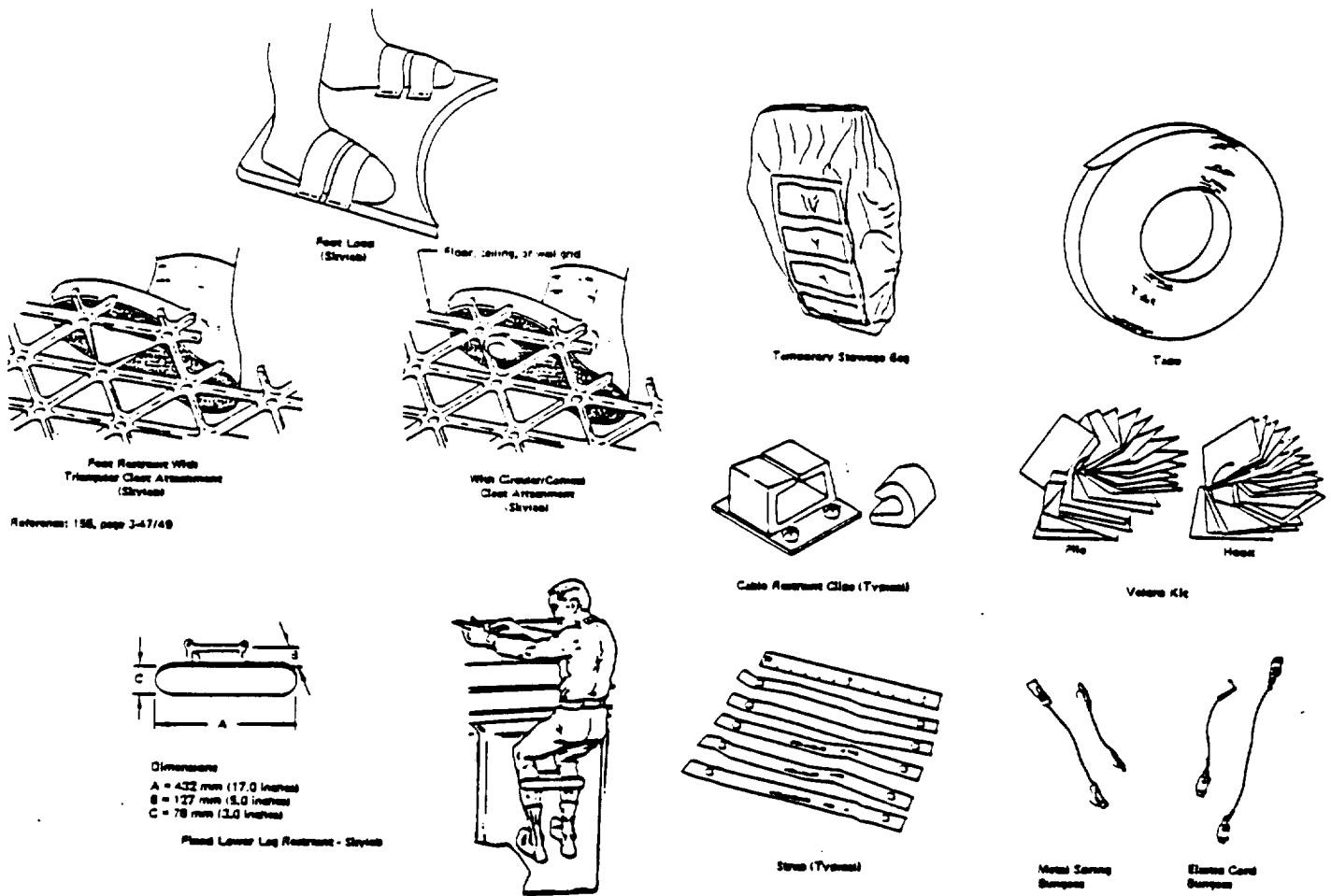

Figure 3B.2. Head and Eye Movement



Reference: 156, page 3-47/49

Figure 3B.3. Restraints for User and Equipment

Parameter	Units	Operational	90-day degraded (1)	28-day emergency
CO ₂ partial press	mmHg	3.0 max	7.6 max	12 max
Temperature (9)	deg. F	65-80	65-80	60-85
Dew point (2)	deg. F	40-60	35-70	35-70
Ventilation	ft/min	15-40	10-100	10-200
O ₂ partial pressure (4)	psia	2.83-3.35	2.4-3.45	2.3-3.45
Total pressure	psia	14.5-14.9	14.5-14.9	14.5-14.9
Diluent gas		N ₂	N ₂	N ₂
Trace contaminants (8)	ppm	TBD	TBD	TBD
Micro-organisms	CFU/m ³ (6)	500 (7)	750 (7)	1000 (7)
Particulates > 0.5 micron	counts/ft ³	100,000 max	TBD	TBD

Table 3B.1. Allowable Atmospheric Contents

The following are instructions for unit operation and maintenance:

1. After insertion of working materials, turn device ON.
2. Slide open the trap door.
3. Perform tasks.
4. Secure all materials and slide work area towards user to allow for hands and arms cleaning. Vacuum inside of the unit.
5. Slide work area back into position and slide close the trap door.
6. Switch device OFF.
7. When accumulation of particles in the filtering system interfere with proper functioning of the unit, vacuum the filtering unit before closing the trap door.
8. The filter can be removed and replaced when deemed necessary by sliding it out of its position.
9. The blowers and motor should be maintained as often as necessary.

REFERENCES

- Berlant, Sigmund. Arenco & Augment Replacement Parts. Pompano Beach, Florida. Personal Interview.
15 March 1991.
- Carroll, Bruce (Low Speed Aerodynamics). University of Florida. Department of Aerospace Engineering, Mechanics, and Engineering Science. Personal Interview.
28 January 1991.
- Doddington, Harold (Instrumentation). University of Florida. Department of Aerospace Engineering, Mechanics, and Engineering Science. Personal Interview.
6 February 1991.
- Gibraltar Biological Laboratories, Inc. Laboratory Report GBL 1456A.
7 December 1973.
- Kurzweg, Ulrich (Fluid Dynamics). University of Florida. Department of Aerospace Engineering, Mechanics, and Engineering Science. Personal Interview.
14 January 1991.
- Mei, Renwei (Fluid Dynamics). University of Florida. Department of Aerospace Engineering, Mechanics, and Engineering Science. Personal Interview.
13 January 1991.
- Volkwein, Jon, and Page, Steven. Canopy-Air Curtain Dust Reductions on a Gathering-Arm Loader. United States Department of the Interior. Report of Investigations 8603.
- Williams, Lockwood, and Duncan, Michael. Pilot Demonstration of the Air Curtain System for Fugitive Particle Control. Environmental Protection Agency. EPA/600/S7-86/041. Mar 1987.

4. Appendix: Photographs of Components for Biomass Management

- A Sected Plant Growth Unit and Hydro-refurbishing System
- A Container and Transfer Mechanism
- An Air Curtain Device for Fugitive Particle Control

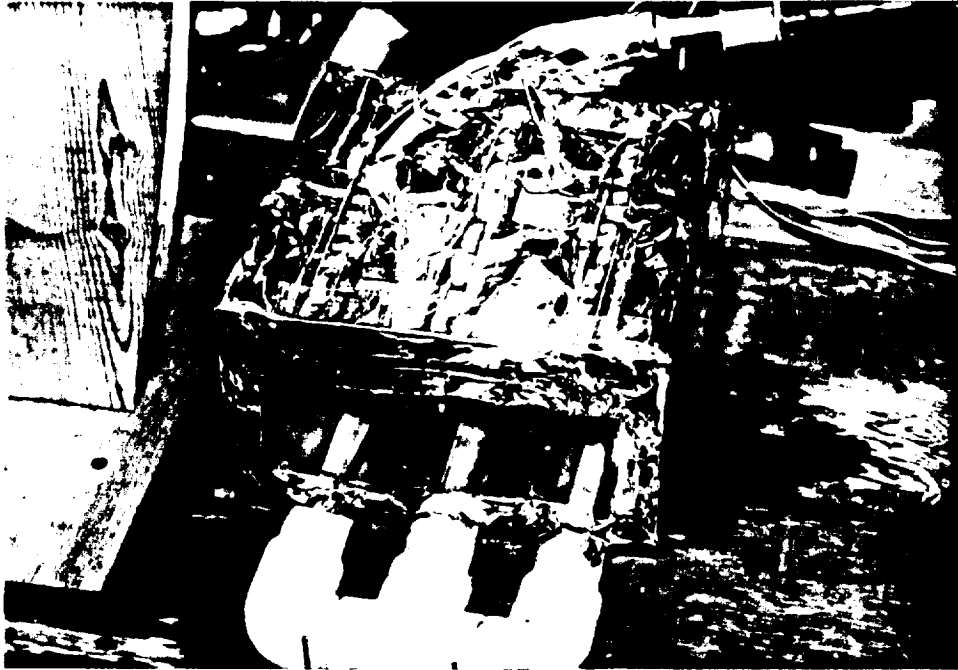

Pic. 1. Sectored Plant Growth Unit (Top View).



Pic. 2. Activated SPGU (Side View).

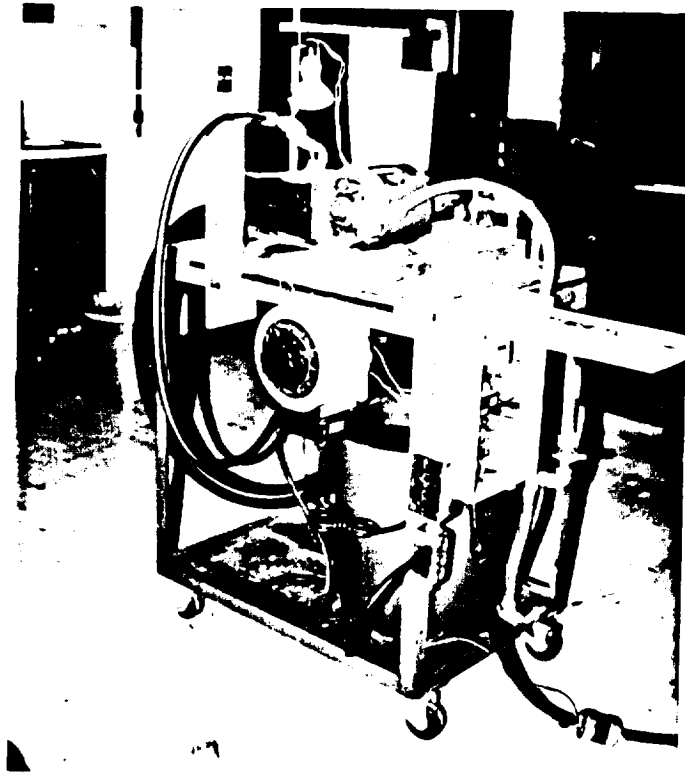

Pic. 3. SPGU and support systems.

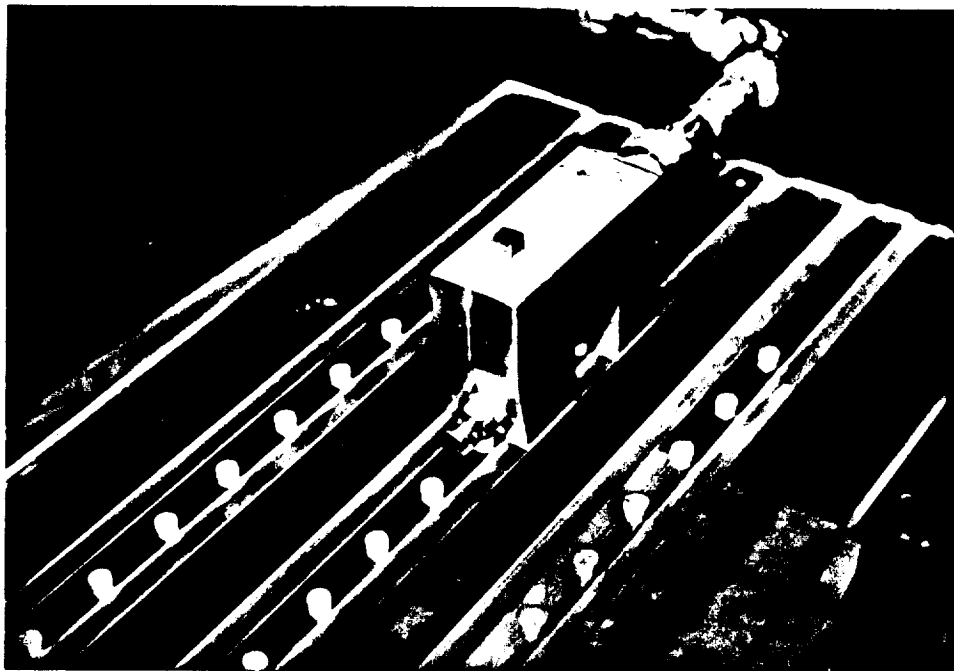

Pic. 4. Hydro-refurbishing block on SPGU surface.

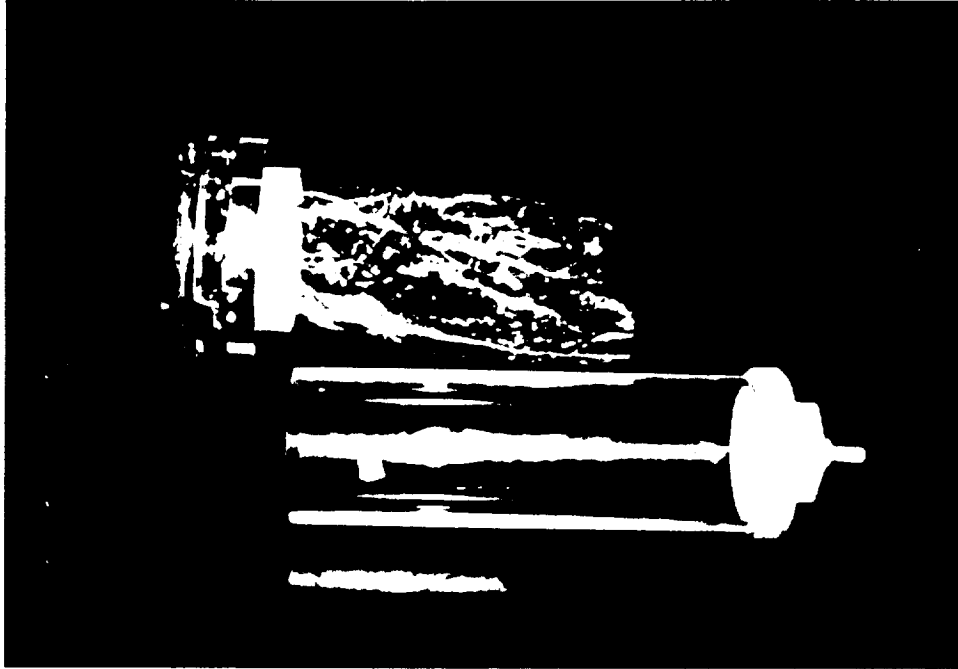

Pic. 5. Container and Receiving Mechanism (disassembled).

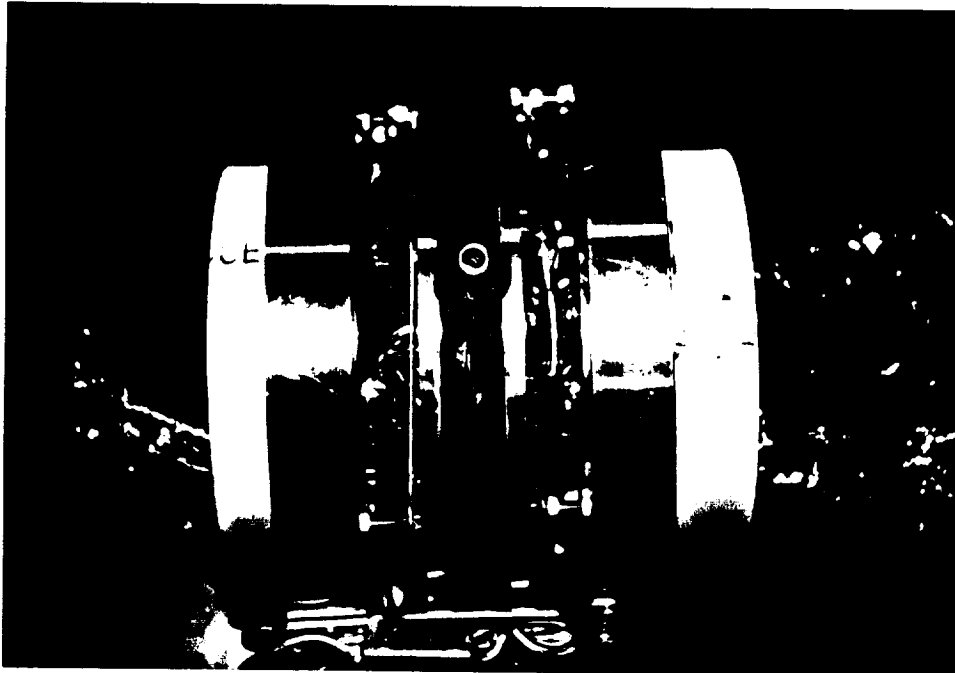

Pic. 6. CARM interlock with another unit for transfer.

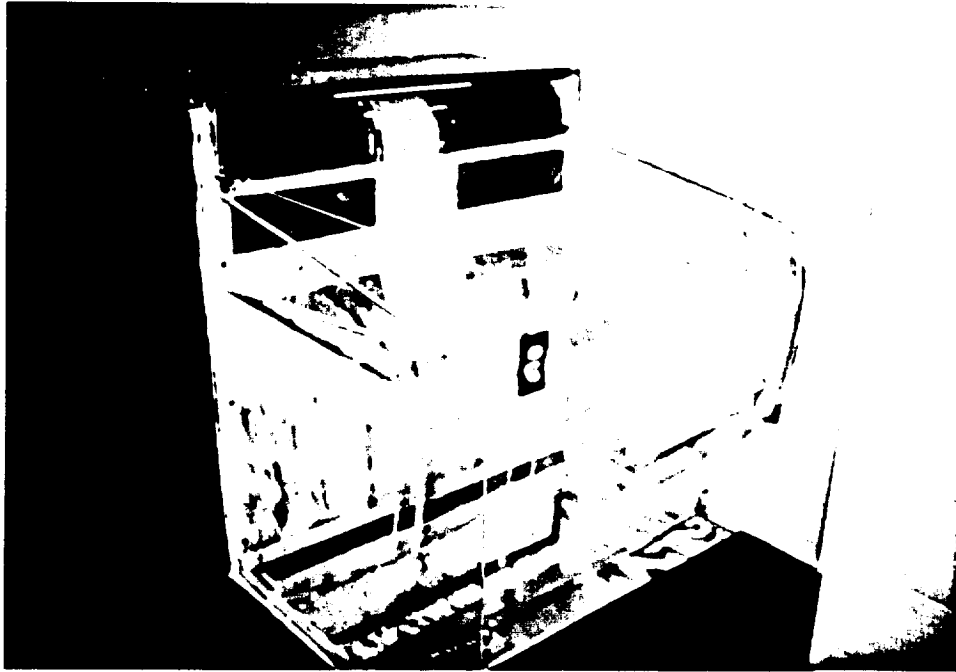

Pic. 7. Air curtain device for fugitive particle control.



Pic. 8. Air curtain device in operation.