

## N O T I C E

THIS DOCUMENT HAS BEEN REPRODUCED FROM  
MICROFICHE. ALTHOUGH IT IS RECOGNIZED THAT  
CERTAIN PORTIONS ARE ILLEGIBLE, IT IS BEING RELEASED  
IN THE INTEREST OF MAKING AVAILABLE AS MUCH  
INFORMATION AS POSSIBLE

PB92-116409

Test Methods for Optical Disk Media Characteristics  
(for 356 mm Ruggedized Magneto-optic Media)

(U.S.) National Inst. of Standards and Technology (NCSL)  
Gaithersburg, MD

Prepared for:

National Aeronautics and Space Administration, Hampton, VA

Sep 91

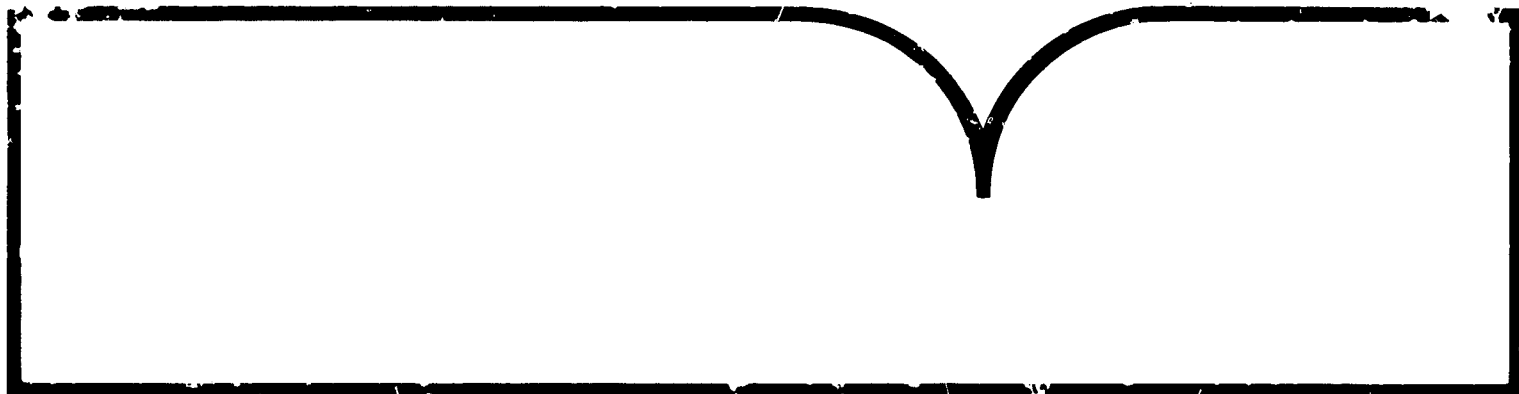

**U.S. Department of Commerce**  
**National Technical Information Service**  
**NTIS**

Computer  
Systems  
Technology

U.S. DEPARTMENT OF  
COMMERCE  
National Institute of  
Standards and  
Technology

**Test Methods for Optical Disk  
Media Characteristics**  
(for 356 mm Ruggedized Magneto-optic Media)

Fernando L. Podio

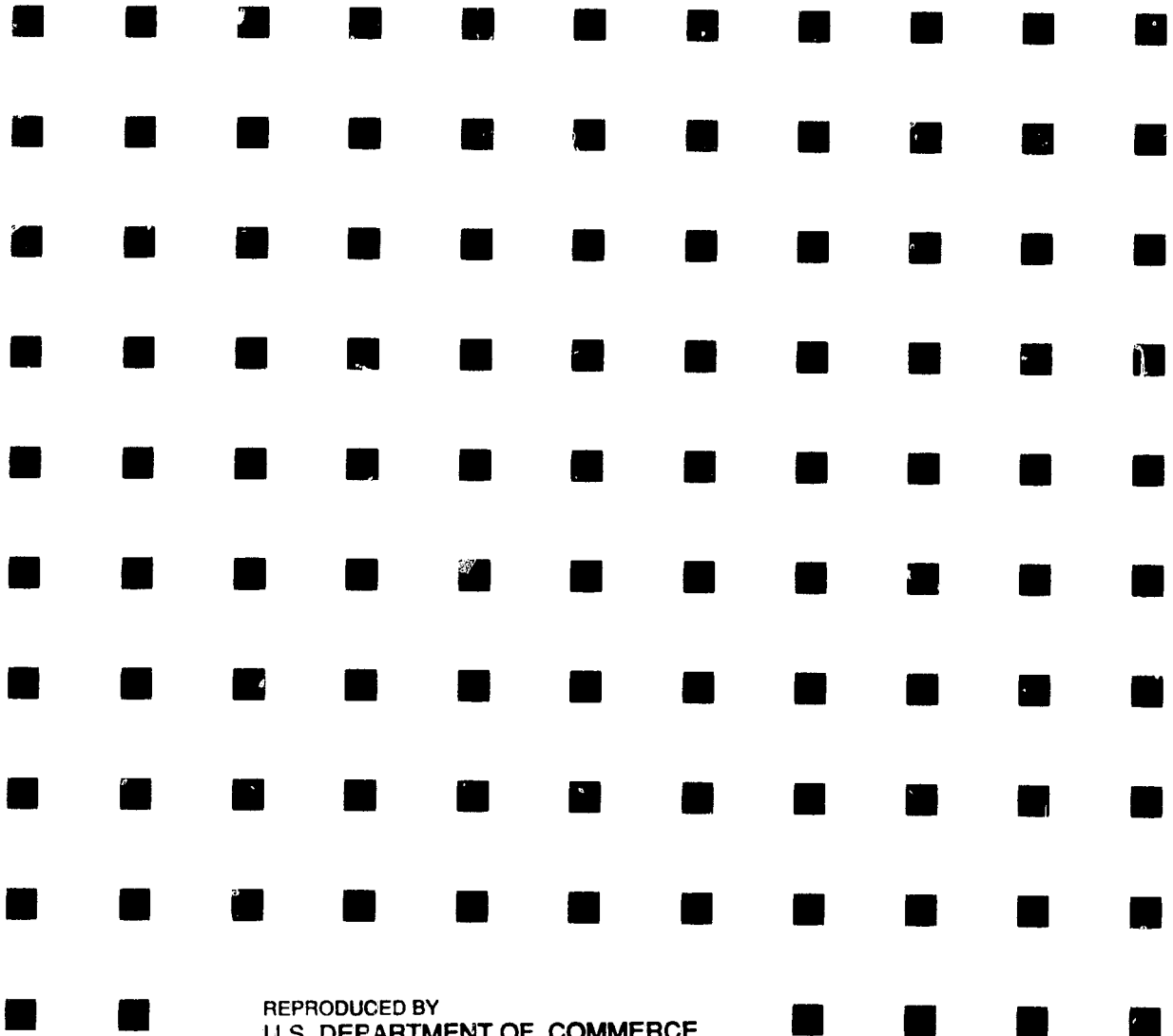

REPRODUCED BY  
U.S. DEPARTMENT OF COMMERCE  
NATIONAL TECHNICAL  
INFORMATION SERVICE  
SPRINGFIELD, VA 22161

# **Test Methods for Optical Disk Media Characteristics**

**(for 356 mm Ruggedized Magneto-optic Media)**

Fernando L. Podio, Editor

Advanced Systems Division  
Computer Systems Laboratory  
National Institute of Standards and Technology  
Gaithersburg, MD 20899

Sponsored by:

National Aeronautics and  
Space Administration  
Langley Research Center  
Hampton, VA 23665-5225

September 1991



**U.S. DEPARTMENT OF COMMERCE**  
**Robert A. Mosbacher, Secretary**  
NATIONAL INSTITUTE OF STANDARDS  
AND TECHNOLOGY  
John W. Lyons, Director

## **Reports on Computer Systems Technology**

The National Institute of Standards and Technology (NIST) has a unique responsibility for computer systems technology within the Federal government. NIST's Computer Systems Laboratory (CSL) develops standards and guidelines, provides technical assistance, and conducts research for computers and related telecommunications systems to achieve more effective utilization of Federal information technology resources. CSL's responsibilities include development of technical, management, physical, and administrative standards and guidelines for the cost effective security and privacy of sensitive unclassified information processed in Federal computers. CSL assists agencies in developing security plans and in improving computer security awareness training. This Special Publication 500 series reports CSL research and guidelines to Federal agencies as well as to organizations in industry, government, and academia.

**National Institute of Standards and Technology Special Publication 500-191**  
**Natl. Inst. Stand. Technol. Spec. Publ. 500-191, 74 pages (Sept. 1991)**  
**CODEN: NSPUE2**

**U.S. GOVERNMENT PRINTING OFFICE**  
**WASHINGTON: 1991**

---

For sale by the Superintendent of Documents, U.S. Government Printing Office, Washington, DC 20402

# Foreword

The National Aeronautics and Space Administration (NASA) is responsible for the Spaceflight Optical Disk Recorder (SODR) program, which is managed by the Langley Research Center. The SODR program includes the concept of developing disk drive storage modules containing high capacity ruggedized erasable optical disks, and the development of a modular controller. This forms the basis for an expandable system that can be configured for specific applications.

The optical disk recorder is intended for use aboard unmanned polar orbiting Earth Observing System (EOS) platforms and Space Station spacecraft. The goal is to have a high performance, high capacity ruggedized erasable optical disk system capable of providing the complex onboard data storage and buffer functions needed for the EOS and Space Station spacecraft. In addition to the space-based applications, there are similar ground-based applications, such as supercomputer mass storage and spaceflight experiment data downlink buffers, that could benefit substantially from advances in storage technology leading to erasable, high-rate, high-capacity systems.

The need for physical interchange standards and standard test methods for measuring media characteristics for the type of media that would be used in these systems is apparent. These standards will allow competing firms to develop products, making it possible for NASA to select a product for which there are multiple vendors. Standard test methods will also allow conformance verification of such standards. At the present time, National and International industry voluntary standards committees are not working in the development of media interchange standards and standard test methods for high performance and high capacity ruggedized erasable media.

Because of the lack of these media interchange standards and standard test methods, in 1989 NASA sponsored a program of work at the National Institute of Standards and Technology (NIST) to develop media specifications and test methods for measuring media characteristics for ruggedized erasable optical disks, by consensus building between NIST, NASA, and interested parties in industry. These media specifications and test methods would be included in two separate documents that would be used as reference documents or as guidelines for U.S. Government agencies and industry interested in specifying and testing this type of media technology.

The Computer Systems Laboratory (CSL), an operational unit of the National Institute of Standards and Technology (NIST), maintains membership in national and international standards committees such as Technical Committee (TC) X3B11 and ISO/IEC JTC1/SC23 in the development of media interchange standards and test methods standards for optical digital data disks. CSL has project leadership for the development of standard test methods for media characteristics in TC X3B11 and maintains membership in the IT9/AES Joint Technical Commission (JTC) on Data Permanence. The work of the JTC will eventually lead to the standardization of methods to predict the life expectancy of optical computer storage media/systems. A member of CSL is also a technical liaison between TC X3B11 and the JTC.

Through its optical media research program, CSL has also been doing research on optical media characteristics for several years. This program which began at CSL in 1985 includes stability studies of optical media, development of a testing laboratory for optical media, and studies of the utilization of this technology. In support of its mission, CSL works with U.S. Government agencies to assist in the development of policies, standards, and methods for efficient management of information resources. CSL currently has a cooperative program with the U.S. National Archives and Records Administration through which CSL developed a testing methodology for deriving life expectancy values for optical media. CSL is now working on a study of care and handling of optical media. CSL is also investigating the status of on-line monitoring techniques for error rates and error distributions on optical disk subsystems.

To help NASA and industry develop media specifications and test methods, CSL organized and chairs a NIST/NASA Working Group whose membership consists of interested drive and media manufacturers, other interested federal government agencies, NIST and NASA. The scope of this Working Group is to develop a set of test methods for measuring media characteristics and a set of specifications for 356 mm ruggedized erasable media/drives. During the first year of activity, the Working Group developed a set of test methods for the media characteristics. The test methods were developed for a 356 mm two-sided laminated glass substrate with a magneto-optic active layer media technology. This publication documents these test methods.

It is my personal expectation that this document will be used as a guideline on how to test this type of media technology. This document should also be a useful contribution to other groups or standards committees in charge of documenting test methods for optical media. The test methods included in this publication may be appropriate for other media types, but their applicability must be evaluated on a case by case basis.

Because of the nature of the work, references were made to specific companies and commercial products. The inclusion or omission of companies or products in this publication does not imply an endorsement or a criticism by the National Institute of Standards and Technology.

**Fernando L. Podio, Chair  
and Technical Editor,  
NIST/NASA Working Group for the development  
of Test Methods and Specifications for  
356 mm Ruggedized Rewritable Media.**



# Acknowledgments

I want to acknowledge all of those who made this work a success, including the Working Group members who are listed in Appendix E. Special thanks are due to: Dr. Thomas A. Shull and John Stadler from NASA, Doug Stinson and Scott Gerger from Kodak, Joe Cinelli and Taras Kozak from GE and Jathan Edwards from 3M. I am also grateful to my NIST colleagues who contributed to the Working Group by providing technical advice and reviewing documents. Some of the tests were derived from material extracted from TC X3B11 draft standards and other TC X3B11 documents (see Chapter 4, References). I am grateful to those TC X3B11 members who, through their contributions to the work of TC X3B11, indirectly contributed to this Working Group.

# Contents

<b>Foreword</b> .....	<b>iii</b>
<b>Acknowledgments</b> .....	<b>vii</b>
<b>Abstract</b> .....	<b>xv</b>
<b>1 General</b> .....	<b>1</b>
1.1 Scope .....	1
1.2 Purpose .....	1
1.3 References .....	1
1.4 Definitions .....	2
<b>2 Testing Conditions</b> .....	<b>3</b>
2.1 General Environment .....	3
2.2 Measurement Precision .....	4
2.3 Mechanical .....	4
2.4 Recording .....	6
2.4.1 General .....	6
2.4.2 Read Conditions .....	8
2.4.3 Write Conditions .....	8
2.4.4 Erase Conditions .....	8
<b>3 Test Methods</b> .....	<b>9</b>
3.1 Operational Environment Test .....	9
3.1.1 Thermal .....	10
3.2 Non-operational Environment Test .....	11

3.2.1	Thermal	11
3.2.2	Humidity	12
3.2.3	Temperature-Altitude	12
3.2.4	Vibration	13
3.3	Storage Environment Test	14
3.3.1	Thermal	14
3.3.2	Humidity	14
3.3.3	Temperature-Altitude	14
3.4	Environmental Qualification	14
3.4.1	Radiation	15
3.4.2	Thermal Vacuum Stability Test (Outgassing)	16
3.4.3	Vibration	16
3.4.4	Thermal Cycling	17
3.4.5	Temperature-Altitude	17
3.5	Mechanical and Physical Characteristics	18
3.5.1	Dimensions of the Disk	18
3.5.2	Moment of Inertia	18
3.5.3	Imbalance	19
3.5.4	Dynamic Axial Runout	19
3.5.5	Axial Acceleration	21
3.5.6	Residual Focus Error	22
3.5.7	Dynamic Radial Runout	24
3.5.8	Radial Acceleration	26
3.5.9	Residual Tracking Error	27
3.5.10	Droop	29
3.5.11	Tilt	29
3.6	Substrate Characteristics	30
3.6.1	Index of Refraction	30
3.6.2	Double-pass Retardation	30
3.6.3	Thickness	31
3.7	Recording Layer Characteristics	31

3.7.1	Reflectance, Uniformity of Reflectance, and Rate of Change of Reflectance . . . . .	31
3.7.2	Resolution . . . . .	32
3.7.3	Imbalance of the Magneto-optic Signal . . . . .	33
3.7.4	Disk Retardation . . . . .	33
3.7.5	Figure of Merit . . . . .	35
3.7.6	Narrow Band Signal-to-noise Ratio . . . . .	36
3.7.7	Crosstalk . . . . .	37
3.7.8	Ease of Erasure . . . . .	38
3.7.9	Optimum Write Power . . . . .	39
3.7.10	Mark Uniformity . . . . .	41
3.7.11	Raw Error Rate . . . . .	42
3.8	Preformat Characteristics . . . . .	43
3.8.1	Push-pull Signal . . . . .	44
3.8.2	Track Crossing Signal . . . . .	44
3.8.3	Preformat Data Signal . . . . .	45
3.8.4	Track Pitch . . . . .	45
3.9	Media Lifetime . . . . .	45
3.9.1	Archival Life . . . . .	46
3.9.2	Shelf Life . . . . .	49
3.9.3	Read/Write/Erase Cycles . . . . .	50
3.9.4	Extended Read . . . . .	50
4	References . . . . .	53
A	The Optical System Seen by any Beam for Measuring Write, Read and Erase Characteristics . . . . .	55
B	Definition of Write Pulse . . . . .	57
C	1500 Hz Filter Implementation . . . . .	59
D	Determination of the Number of Transitions Required for the Raw Error Rate Test . . . . .	61
E	Working Group Participants . . . . .	63

## List of Figures

2.3.a	Disk plan view . . . . .	4
2.3.b	Disk clamping method . . . . .	5
3.1.1	Thermal cycle . . . . .	10
3.5.2	Moment of inertia test setup . . . . .	18
3.5.4	Dynamic axial runout block diagram . . . . .	20
3.5.6	Residual focus error test system . . . . .	23
3.5.7	Dynamic radial runout block diagram . . . . .	26
3.5.9	Residual tracking error test system . . . . .	28
3.5.11	Tilt test setup . . . . .	30
3.6.2	Double-pass retardation test setup . . . . .	31
3.7.3	Imbalance of the magneto-optic signal . . . . .	33
3.7.4	Disk retardation test instrument . . . . .	34
3.7.6	Amplitude versus frequency . . . . .	37
3.7.9	Mark length error versus write power . . . . .	40
3.7.11	Raw error rate test setup . . . . .	43
3.8	Preformat characteristics . . . . .	44
3.9.1.a	Incubation effect on the raw error rate . . . . .	47
3.9.1.b	Extrapolated $t_{EOL}$ value for the archival and shelf life tests . . . . .	48
A.1	The optical system seen by any beam for measuring write, read, and erase characteristics for Type A.1 detection. . . . .	56
B.1	Definition of write pulse . . . . .	57
C.1	1500 Hz filter implementation . . . . .	59

# List of Tables

2.1	General environment . . . . .	3
2.4.1	Testing conditions . . . . .	7
3.1	Parameters for the operational, non-operational, and storage environment tests . . . . .	9
3.4.1	Parameters for the radiation test . . . . .	15
3.4.4	Parameters for the thermal cycling test . . . . .	17
3.9.3	Parameters for the read/write/erase cycles test . . . . .	51

# **Test Methods for Optical Disk Media Characteristics (for 356 mm Ruggedized Magneto-optic Media)**

Fernando L. Podio  
Technical Editor

## **Abstract**

Standard test methods for computer storage media characteristics are essential and allow for conformance verification to media interchange standards. Test methods are also needed to develop procedures which would allow for repeatability of results among different industry and U.S. Government sites. The test procedures documented in this publication reflect the work done by the NIST/NASA Working Group for the Development of Test Methods and Specifications for 356 mm Ruggedized Rewritable Media. The test methods were developed for 356 mm two-sided laminated glass substrate with a magneto-optic active layer media technology. These test methods may be used for testing other media types, but in each case their applicability must be evaluated. Test methods are included for a series of different media characteristics including: operational, non-operational, and storage environments, mechanical and physical characteristics, and substrate, recording layer, and preformat characteristics. Tests for environmental qualification and media lifetimes are also included. The test methods include testing conditions, testing procedures, a description of the testing setup, and the required calibration procedures.

Key words: erasable media, magneto-optic media, media lifetime, optical disk media, ruggedized optical media, test methods.

# Chapter 1

## General

### 1.1 Scope

This publication specifies test methods for media characteristics of ruggedized optical disks with 356 mm two-sided laminated glass substrate with a magneto-optic active layer used for information processing systems and for information storage. These test methods can be used to measure quantities frequently given in a media specifications document. In an effort to maintain generality, in many cases specific numbers are not given. Instead, the reader is referred to the appropriate media specifications document. These test methods may be appropriate for other media. Their applicability must be evaluated on a case by case basis.

### 1.2 Purpose

This publication provides test methods and test procedures for media characteristics. These procedures may be used to verify conformance with a related media specification standard or as a guideline for measuring media characteristics of the type described in section 1.1.

### 1.3 References

Chapter 4 includes a list of publications and standards. Some of the standards contain information which, through references in this text, constitute provisions of this publication. At the time of publication, the indicated editions of these standards were valid.



## **1.4 Definitions**

### **Collected Volatile Condensable Material (VCM) - (see sec. 3.4.2)**

Quantity of outgassed material from a test specimen that condenses on a collector maintained at a specific constant temperature for a specified time. VCM is expressed as a percentage of the initial specimen mass and is calculated from the condensate mass determined from the difference in mass of the collector plate before and after the test.

### **Total Mass Loss (TML) - (see sec. 3.4.2)**

Total mass of material outgassed from a specimen that is maintained at a specified constant temperature and operating pressure for a specified time. TML is calculated from the mass of the specimen as measured before and after the test and is expressed as a percentage of the initial specimen mass.

### **Dynamic Axial Runout - (see sec. 3.5.4)**

The dynamic axial runout is the peak-to-peak axial deflection of the disk measured while rotating the disk according to the test conditions.

### **Dynamic Radial Runout - (see sec. 3.5.7)**

The dynamic radial runout is the peak-to-peak radial deflection of the features used to define a track as the disk rotates.

### **Droop - (see sec. 3.5.10)**

Droop is the axial displacement of the recording layer between the disk inner recording radius and the outer recording radius.

# Chapter 2

## Testing Conditions

All of the following test methods assume that the testing systems are under statistical control.

### 2.1 General Environment

Unless otherwise specified, tests and measurements made on the optical disk to check the requirements of this publication shall be carried out in an environment where the air immediately surrounding the optical disk is under the conditions shown in table 2.1.

Table 2.1. General environment

Parameter	Value
Temperature	23 °C ± 2 °C
Relative humidity	45% to 55%
Atmospheric pressure	7.5 * 10 <sup>4</sup> Pa to 10.5 * 10 <sup>4</sup> Pa
Air cleanliness	Class 100,000

The optical disk shall be conditioned in this environment for 24 hours minimum before any testing. No condensation on the optical disk shall occur.

## 2.2 Measurement Precision

A property is in conformance with a specification if and only if:

$$LSL + 3s < x < USL - 3s$$

where,  $x$  is the measurement of the property in question,  $LSL$  is the lower specification limit,  $USL$  is the upper specification limit and  $s$  is the sample standard deviation of the measurement. If only one specification limit is given, then only the condition for that limit need be met.

## 2.3 Mechanical

- a) Figure 2.3.a shows a disk plan view, where  $OD$  is the outside diameter and  $ID$  is the inside diameter.  $R1$  is the write/read area outer radius,  $R2$  is the write/read area, inner radius,  $R3$  is the outer clamping radius, and  $R4$  is the inner clamping radius.

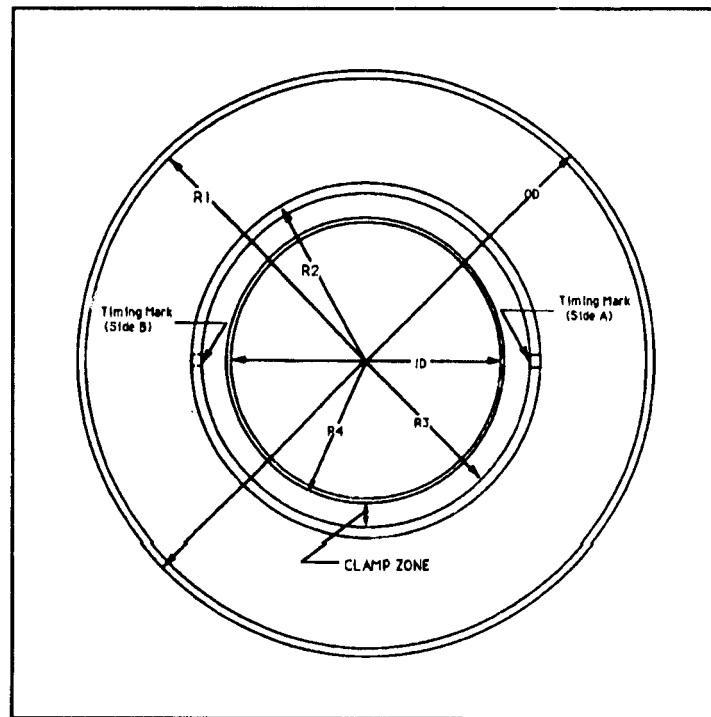

Figure 2.3.a. Disk plan view.

- b) The surface which contacts the optical disk at the clamp zone during testing, shall have a maximum axial and radial runout of  $0.05 \mu\text{m}$  (see fig. 2.3.a and 2.3.b). The finish of the surface which contacts the optical disk at the clamp zone shall have a maximum arithmetic average of  $0.4 \mu\text{m}$ .
- c) A clamping force  $F$  within the following range shall be applied uniformly over the clamp zone.

$$667 \text{ newton} < F < 1557 \text{ newton}$$

Accepted industry practice shall be used to measure the clamping force.

- d) Clamping Method

Any clamping method that accomplishes the requirements of section 2.3.b and 2.3.c shall be used. An illustration of one such method is shown in figure 2.3.b.

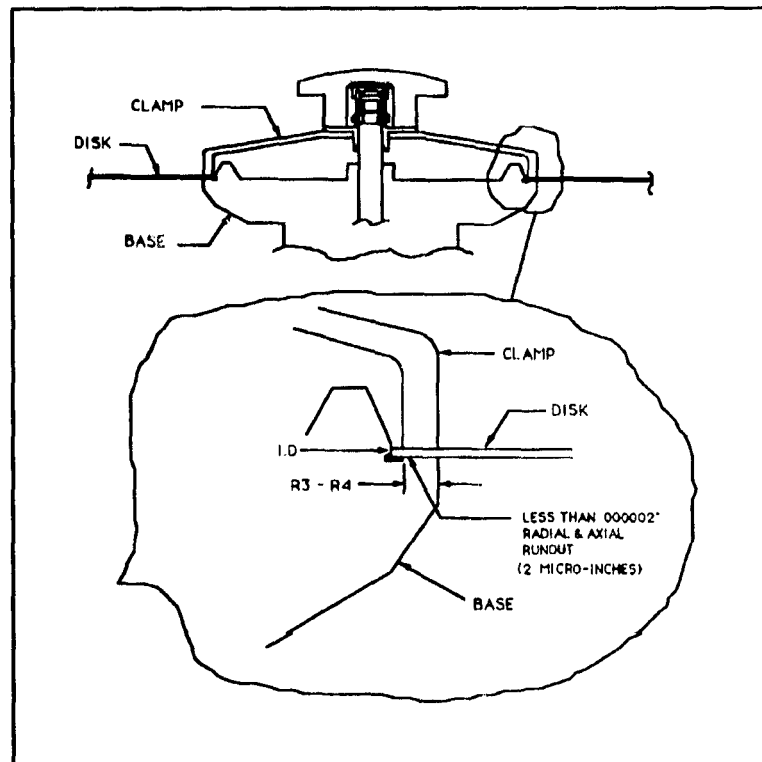

Figure 2.3.b. Disk clamping method.

## **2.4 Recording**

### **2.4.1 General**

There are test conditions specified for two recording objectives of different numerical apertures (NA):

Test condition A: for  $NA = 0.60$

Test condition B: for  $NA = 0.68$

Unless otherwise specified the test condition applies for test conditions A and B.

**Table 2.4.1. Testing conditions**

<b>Parameter</b>	<b>Value or condition</b>
Environment	See section 2.1
Wavelength	830 nm $\pm$ 20 nm
Wavelength/NA for test condition A	1.38 $\mu$ m $\pm$ 0.03 $\mu$ m
Wavelength/NA for test condition B	1.22 $\mu$ m $\pm$ 0.02 $\mu$ m
Filling of the lens aperture D/W (1)	1.0 max.
Wavefront at the disk (2):	
Third order astigmatism	$\leq$ 0.13
Third order coma	$\leq$ 0.10
Third order spherical aberration	$\leq$ 0.35
Detection method	Differential (see app. A)
Extinction ratio	0.01 max. (see app. A)
Rotational frequency of the disk	18.0 Hz $\pm$ 0.2 Hz

**Notes:**

1. In the parameter filling of the lens aperture, D is the diameter of the lens aperture and W is the  $1/e^2$  beam diameter of the gaussian beam.
2. For the wavefront at the disk, the total RMS wavefront variance shall be  $\leq$  0.046. Coma is the most significant aberration affecting performance. An optical system providing a Strehl ratio of 0.92 while meeting the specification for coma will be adequate for these test methods.

## **2.4.2 Read Conditions**

The read power shall be 2.0 mW.

## **2.4.3 Write Conditions**

- a) For those test methods that require writing a track with the optimum write power, the write power shall be as determined by the test method described in section 3.7.9.
- b) For those test methods in section 3.7 that require a write power range, tests are to be performed in the range of 4 mW to 12 mW.
- c) Marks are written on to the disk by pulses of optical power superimposed upon a specified bias power of 2.0 mW.
- d) The pulse shape shall be as specified in appendix B.
- e) The write power is the optical power incident at the entrance surface of the disk.
- f) The magnetic field intensity used to write shall be between 18 000 A/m and 32 000 A/m. The write magnetic field shall be normal to the recording surface ( $\pm 5^\circ$ ). The direction of the write magnetic field shall be from the entrance surface to the recording layer.

## **2.4.4 Erase Conditions**

- a) The erase power shall be the optimum write power as defined by the test method described in section 3.7.9. The required power shall not exceed 12 mW.
- b) The magnetic field intensity used to erase written marks shall be between 18 000 A/m and 32 000 A/m and shall be normal to the recording surface ( $\pm 5^\circ$ ). The direction of the magnetic field shall be from the recording layer to the entrance surface.

# Chapter 3

## Test Methods

### 3.1 Operational Environment Test

The operational environment is the environment encountered when the optical disk is installed in the drive and the drive is operating. Therefore all operational environment testing on the optical disk will be performed while the optical disk is spinning. The rotational rate of the disk is specified in section 2.4.1. All "Operational Environment" tests are performed by first testing some media characteristics and then, while exposing the disk to the operational environment, retesting the media characteristics to observe any change in the originally measured parameter. Unless otherwise specified, the parameters listed in table 3.1 shall be measured before and after each test.

**Table 3.1. Parameters for the operational, non-operational, and storage environment tests**

<b>Test</b>	<b>Section Number</b>
Dynamic Axial Runout	3.5.4
Axial Acceleration OR	3.5.5
Residual Focus Error	3.5.6
Dynamic Radial Runout	3.5.7
Radial Acceleration OR	3.5.8
Residual Tracking Error	3.5.9
Droop	3.5.10
Tilt	3.5.11
Raw Error Rate	3.7.11



### 3.1.1 Thermal

#### 1) General

Thermal cycling between temperature extremes is performed to verify performance at other than stabilized conditions including level extremes and temperature gradient shifts, thus inducing stress intended to uncover incipient problems. For this test the disk (and only the disk) is heated while it is rotating. This may be done by using infrared lamps shining on the disk or by using a special chamber to house the disk (the chamber shall have a small slot to allow the laser beam(s) to reach the disk, an opening for the drive shaft, and be capable of being heated). Additional apparatus consists of auxiliary instrumentation capable of maintaining and continuously monitoring the required conditions of temperature of the air surrounding the test disk.

#### 2) Test Procedure

- a) Continuous recording of the disk and chamber temperature (if applicable) is required. The disk temperature may be measured by use of an infrared pyrometer (preferred) or approximated by placing a thermocouple very near the disk surface and away from any heat lamp (if applicable).
- b) Thermally cycle the disk per figure 3.1.1 to the levels specified in the appropriate media specifications document.

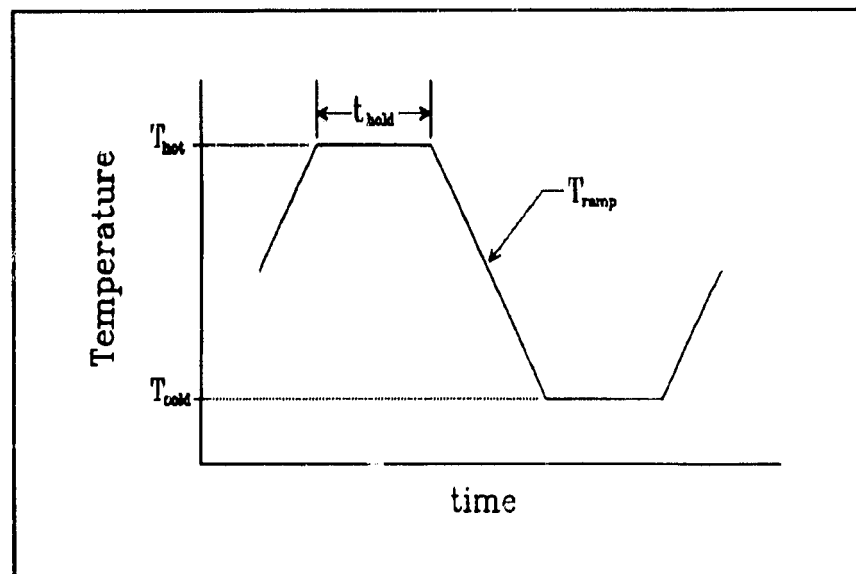

Figure 3.1.1. Thermal cycle.

Figure 3.1.1 includes the following parameters:

$T_{hot}$  : upper temperature limit  
 $T_{cold}$  : ambient temperature  
 $T_{rate}$  : temperature rate of change  
 $t_{hold}$  : time at temperature bounds  
 $n$  : number of cycles

The tolerances for the temperature and temperature rate are:

Temperature:  $\pm 2$  °C  
Temperature rate:  $\pm 10\%$

## 3.2 Non-operational Environment Test

The non-operational environment is the type of environment encountered when the optical disk is installed in the drive and the drive is not operating (examples: spacecraft integration, prelaunch, spacecraft launch, spacecraft landing). The optical disk is not spinning during the non-operational environment tests. All "Non-Operational Environment" tests are performed by first testing some media characteristics, then exposing the disk to the non-operational environment and subsequently retesting the media characteristics to observe any change in the originally measured parameter. Unless otherwise specified, the parameters listed in table 3.1 shall be measured before and after each test.

### 3.2.1 Thermal

#### 1) Test Setup

The required apparatus consists of a chamber or cabinet together with auxiliary instrumentation capable of maintaining and continuously monitoring the required conditions of temperature throughout the envelope of air surrounding the test disk.

#### 2) Test Procedure

- a) The thermal chamber may be at ambient pressure with a chamber environment of air or gaseous nitrogen.
- b) The thermal chamber shall be examined to ensure that it is not a contributing source of contamination.

- c) Continuous recording of the chamber and disk temperature is required.
- d) To avoid condensation, the test shall begin and end with a hot soak.
- e) In the thermal chamber, temperature cycle the disk according to the cycle shown in figure 3.1.1, to the levels specified in the appropriate media specifications document with the following tolerances:

Temperature:  $\pm 2 \text{ }^\circ\text{C}$   
Temperature rate:  $\pm 10\%$

### **3.2.2 Humidity**

Perform the humidity test per Mil-Std-810E Method 507.3, Procedure III.

### **3.2.3 Temperature-Altitude**

#### **1) Test Setup**

The required apparatus consists of a thermal/vacuum chamber with auxiliary instrumentation capable of maintaining and continuously monitoring the required conditions of temperature and pressure throughout the envelope surrounding the test disk.

#### **2) Test Procedure**

- a) The thermal/vacuum chamber shall be examined to ensure that it is not a contributing source of contamination.
- b) Continuous recording of the chamber temperature and pressure and disk temperature is required.
- c) Evacuate the thermal/vacuum chamber to the pressure specified in the appropriate media specifications document.
- d) In the thermal/vacuum chamber, temperature cycle the disk per figure 3.1.1 to the levels specified in the appropriate media specifications document with the following temperature and pressure tolerances:

Temperature:  $\pm 2 \text{ }^\circ\text{C}$   
Temperature rate:  $\pm 10\%$

**Pressure:**

Greater than  $1.33 \times 10^4 \text{ Pa}$  : +5%, -0%  
 $1.33 \times 10^4 \text{ Pa}$  to  $1.33 \times 10^2 \text{ Pa}$  :  $\pm 10\%$   
 $1.33 \times 10^2 \text{ Pa}$  to  $1.33 \times 10^{-4} \text{ Pa}$  :  $\pm 25\%$   
Less than  $1.33 \times 10^{-4} \text{ Pa}$  : +0%, -80%

### 3.2.4 Vibration

#### 1) Introduction

The disk shall be subjected to random vibration along axes normal to the disk plane and parallel to the disk plane.

#### 2) Test Setup

The disk shall be mounted to the test equipment by a rigid test fixture. The test fixture shall provide uniform clamp force over the clamp zone as shown in figure 2.3.a. For the purpose of controlling the vibration, calibrated accelerometer(s) shall be attached rigidly on the test fixture near the test fixture/disk interface and aligned with the axis of the applied vibration.

**Note:**

This test method has no requirements for response accelerometer(s). If however, response accelerometer(s) are used, it is not recommended to mount them directly to the glass disk as this may cause damage to the disk when removing the accelerometer(s). It is advised to apply a strip of Kapton pressure sensitive tape (example: 3M Scotch 5413 Kapton Film Tape or equivalent) to the glass disk, and mount the response accelerometer to the tape.

#### 3) Test Procedure

With the disk mounted on the vibrator, initially perform a 1 g RMS random survey over the frequency band (listed in the appropriate media specifications document) to evaluate test setup and disk response. Perform the random vibration according to the specification listed in the appropriate media specifications document. The excitation spectrum, as measured by the control accelerometer(s), shall be equalized such that the overall RMS level is within  $\pm 10\%$  of that specified. The power spectral density shall

be within  $\pm 3$ dB of the specified levels everywhere in the frequency band.

### **3.3 Storage Environment Test**

In the storage environment the optical disk is not installed in the drive device, but stored in it's own handling container. All "Storage Environment" tests are performed by first testing some media characteristics, then exposing the disk to the storage environment, and subsequently retesting the media characteristics to observe any change in the originally measured parameter. Unless otherwise specified, the parameters listed in table 3.1 shall be measured before and after each test.

#### **3.3.1 Thermal**

Using the test method described in section 3.2.1, thermally cycle the disk using the specifications listed in the appropriate media specifications document.

#### **3.3.2 Humidity**

Perform the humidity test per MIL-STD-810E Method 507.3 Procedure III.

#### **3.3.3 Temperature-Altitude**

Using the test method described in section 3.2.3, perform temperature-altitude tests using the specifications listed in the appropriate media specifications document.

### **3.4 Environmental Qualification**

These tests are performed only on sample optical disk(s). The tests are to qualify the disk design for space flight. The optical disk(s) used for environmental qualification tests are to be of the same design and manufacturing process as deliverable disks. Optical disk(s) which have undergone environmental qualification tests cannot later be used as deliverable disks. A deliverable optical disk has had its design qualified, but has not undergone environmental qualification testing. All "Environmental Qualification" tests are performed by first testing some media characteristics, then exposing the disk to the environmental qualification environment, and subsequently retesting the media characteristics to observe any change in the originally measured parameter.

### 3.4.1 Radiation

#### 1) Introduction

The parameters listed in table 3.4.1 shall be measured before and after each test:

**Table 3.4.1. Parameters for the radiation test**

Test	Section Number
Reflectance	3.7.1
Narrow Band Signal-to-noise Ratio	3.7.6
Ease of Erasure	3.7.8
Optimum Write Power	3.7.9
Mark uniformity	3.7.10
Raw Error Rate	3.7.11

#### **Note:**

For the case where sections of the surface are exposed to radiation, the test methods shall be conducted only over that region. For all the tests the section of the surface exposed shall be large enough to give statistically significant results.

#### 2) Gamma Radiation Test Procedure

Expose a disk's recordable surface (or a section of the surface) to a cobalt-60 source for a sufficient duration to achieve a gamma radiation dose equal to (or greater than) the level listed in the appropriate media specifications document. Visible discoloration of the optical disk after the gamma radiation test is not an indication of passage or failure of this test.

#### 3) Electron Radiation Test Procedure

Expose a disk's recordable surface (or a section of the surface) to an electron radiation source for a sufficient duration to achieve an electron radiation dose equal to (or greater than) the level listed in the appropriate media specifications document. Visible discoloration of the optical disk after the electron radiation test is not an indication of passage or failure of this test.

### **3.4.2 Thermal Vacuum Stability Test (Outgassing)**

#### **1) Introduction**

Due to possible contamination to the spacecraft, astronauts and other equipment, nonmetallic materials for spaceflight applications must be contained in an environmentally sealed container or pass stringent thermal vacuum stability tests. Since outgassing test chambers are usually quite small, the outgassing test shall be performed on the separate material compounds or components which comprise the optical disk.

There are no media characteristics tests before or after the outgassing test.

#### **Note:**

If the material has previously been tested and is listed in the NASA MSFC-HDBK-1674 "Compilation of TVS Data for Nonmetallic Materials"[3], then the material does not have to be tested again.

#### **2) Test Procedure**

The Thermal Vacuum Stability Test shall be conducted per requirements of SP-R-0022 "Vacuum Stability Requirements for Polymeric Materials for Spacecraft Applications"[4], and ASTM E 595-84, "Test Method for Total Mass Loss and Collected Volatile Condensable Materials from Outgassing in a Vacuum Environment"[5]. For the maximum allowable TML and VCM see the specifications listed in the appropriate media media specifications document.

### **3.4.3 Vibration**

#### **1) General**

Using the test method described in section 3.2.4, randomly vibrate the disk using the levels listed in the appropriate media specifications document.

The parameters listed in table 3.1 shall be measured before and after the test.

### 3.4.4 Thermal Cycling

Using the test method described in section 3.2.1, thermally cycle the disk using the specifications listed in the appropriate media specifications document.

The parameters listed in table 3.4.4 shall be measured before and after the test.

**Table 3.4.4. Parameters for the thermal cycling test**

<b>Test</b>	<b>Section Number</b>
Dynamic Axial Runout	3.5.4
Axial Acceleration OR	3.5.5
Residual Focus Error	3.5.6
Dynamic Radial Runout	3.5.7
Radial Acceleration OR	3.5.8
Residual Tracking Error	3.5.9
Droop	3.5.10
Tilt	3.5.11
Narrow band Signal-to-noise Ratio	3.7.6
Crosstalk	3.7.7
Ease of Erasure	3.7.8
Optimum Write Power and Sensitivity	3.7.9
Mark Uniformity	3.7.10
Raw Error Rate	3.7.11
Push-pull Signal	3.8.1
Preformat Data Signal	3.8.3

### 3.4.5 Temperature-Altitude

Using the test method described in section 3.2.3, perform temperature-altitude tests using the specifications listed in the appropriate media specifications document.



## 3.5 Mechanical and Physical Characteristics

### 3.5.1 Dimensions of the Disk

Accepted industry practice shall be used to measure the dimensions of the disk.

### 3.5.2 Moment of Inertia

#### 1) Test Procedure

- a) Suspend the optical disk by three cords as shown in figure 3.5.2.

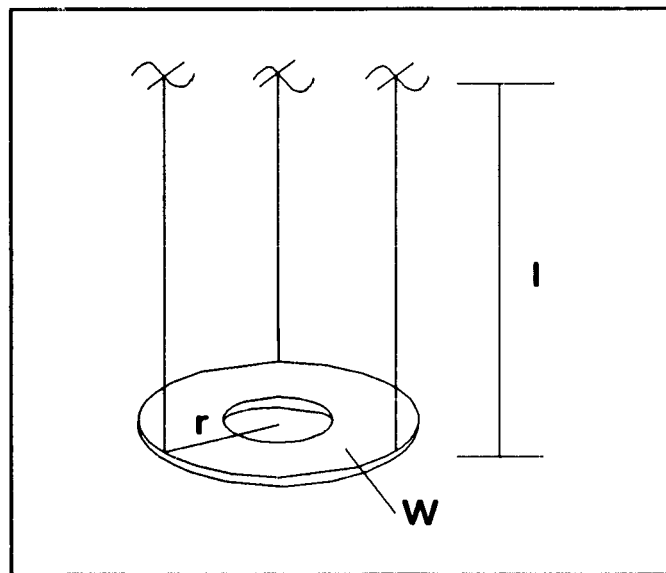

Figure 3.5.2. Moment of inertia test setup.

- b) Start the disk oscillating by rotating it not more than 45 degrees from the rest position.
- c) At a convenient point during the oscillation, begin timing until 100 oscillations have been completed. One oscillation is defined as the time required for the disk to rotate one complete cycle from the starting point until it reaches the starting point again by rotating in the same direction.
- d) Determine the moment of inertia from the following expression:

$$l = \frac{7.06 * W * r^2 * T^2}{I}$$

where: I is the moment of inertia (in kg\*m<sup>2</sup>), W is the weight (in newton), r is the radius at which the suspending cords are attached (in meters), T is the time for one complete oscillation (in seconds), and l is the length of cords (in meters)

**Note:**

The support shall be sufficiently flexible so as not to impede rotation.

### 3.5.3 Imbalance

Imbalance of the disk can cause excessive radial runout and corrupt linear velocity uniformity. Testing the imbalance of the disk requires the use of commonly available dynamic balancing equipment. Imbalance testing should be conducted at the highest operating angular velocity (RPM) for the system as specified in the appropriate media specification document.

### 3.5.4 Dynamic Axial Runout

#### 1) Introduction

The dynamic axial runout shall be measured using the system shown in figure 3.5.4. For frequencies below the resonance of the focus actuator the transfer function is constant and the actuator drive current is proportional to the axial position of the focused spot. Under these conditions, and when a servo system is used to maintain focus, the drive current is also proportional to the disk surface position, provided the focus error signal is sufficiently small.

#### 2) Calibration

##### a) Actuator Drive Current

While using a servo system to maintain focus on a stationary disk, vary the distance between the optical head and the disk. Measure the distance with an accuracy of better than 0.25μm. Record the actuator drive current as a function of head-disk distance. The ratio of displacement to drive current is equal to K<sub>1</sub>/K<sub>2</sub>.

b) Residual Focus Error

With the focus servo off, mechanically adjust the optical head to bring a stationary disk into focus. Vary the distance between disk and the head, both above and below the focus position. Measure the distance to an accuracy of better than  $0.25\mu\text{m}$  and record the error signal as a function of distance.

3) Test Conditions

Measurements shall be taken at three separate radii: 110 mm, 140 mm, and 170 mm.

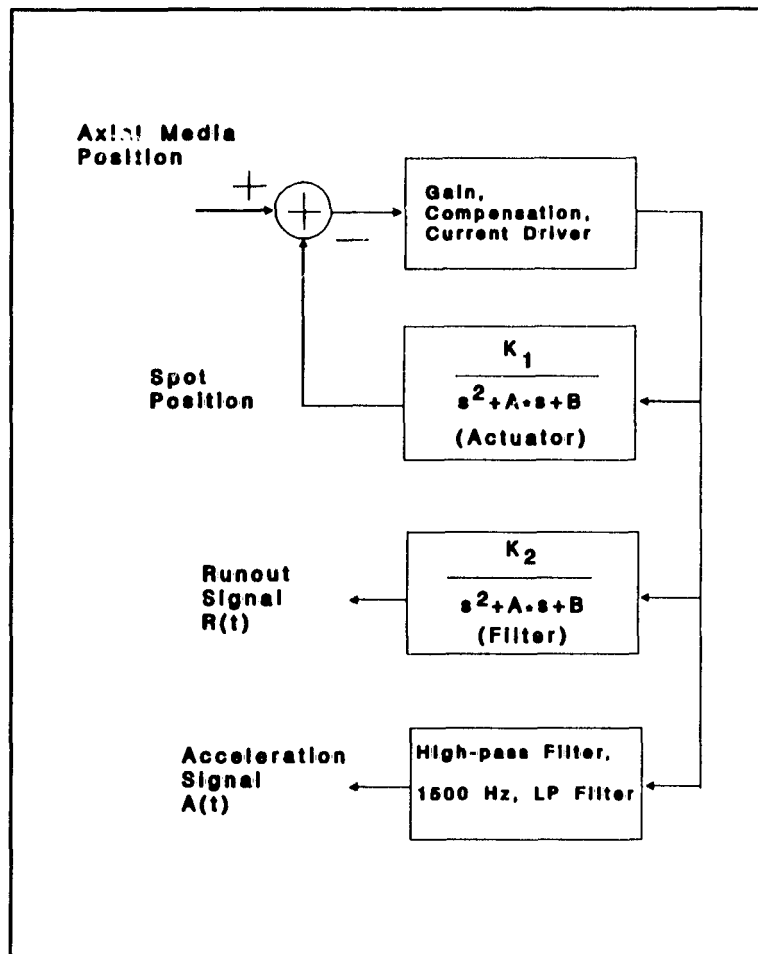

Figure 3.5.4. Dynamic axial runout block diagram.

#### 4) Test Procedure

- a) Obtain the actuator transfer function. Define a filter network with the same denominator as the actuator mass-spring-damper system (parasitic resonances are ignored)

**Note:**

For frequencies below the resonant frequency of the actuator this step can be ignored.

- b) While using a servo system to maintain focus, measure the peak-to-peak actuator drive current during a revolution of the disk.
- c) The displacement equals the peak-to-peak drive current times  $K_1/K_2$ , where  $K_1/K_2$  is determined by the calibration procedure.
- d) When using this method, the maximum residual focus error shall correspond to a displacement of less than 1% of the maximum runout specified in the appropriate media specifications document.

### 3.5.5 Axial Acceleration

#### 1) Introduction

The actuator current is proportional to the acceleration of the lens, when considering frequencies above the natural frequency of the actuator.

#### 2) Calibration

Calibration of acceleration requires the determination of  $(K_1/K_2)$  as explained in section 3.5.4 in the calibration of the dynamic axial runout.  $K_2$  is determined by inspection of the filter.

#### 3) Test Conditions

Measurements shall be taken at three separate radii: 110 mm, 140 mm, and 170 mm.

#### 4) Test Procedure

- a) Choose a band-pass filter with characteristics such that the lower frequency limit is 30 Hz, when taken in series with the natural frequency characteristics of the actuator. Unlike the upper specified frequency limit of 1500 Hz, the lower

frequency limits are not critical at all (in fact, it may be shown that a disk must be significantly over the runout specification at 30 Hz to exceed the 30 Hz acceleration specification). The filter shall be a 4th-order maximally flat ("Butterworth") filter. Appendix C shows an example of this implementation.

- b. By expressing the constant K1 in terms of the measurable quantities K1/K2 and K2, the acceleration signal A(t) is related to the acceleration of the media, as follows:

$$\text{Acceleration of the media} = A(t) * (K1/K2) * K2$$

### 3.5.6 Residual Focus Error

#### 1) Introduction

Residual focus error can be caused by thickness variations in the substrate as well as dynamic axial runout and acceleration of the disk. Furthermore, it is necessary to measure the completed optical disk assembly to assure compliance with the specification for residual focus error in the appropriate media specifications document. Residual focus error for the optical disk shall be measured using the system shown in concept in figure 3.5.6.

The closed loop focus servo system shall have sufficient bandwidth such that the residual focus error signal provides a linear, high-resolution measurement of disk position. A position sensor is employed to provide a high resolution measurement of the focusing lens position, therefore also the disk. This sensor can be an interferometer, or an optical, capacitive, or electromagnetic device with bandwidth at least equal to that of the low performance servo system. When the residual focus error signal is added to the lens position sensor signal, an exact measure of the position of the disk is achieved. This disk position signal shall then be processed by a digital or analog filter whose disturbance rejection transfer function is given in equation 3.5.6. The output of the filter is a measure of the residual focus error produced by such a "standardized" servo system.

Equation 3.5.6:

$$\frac{\text{Residual focus error}}{\text{Disk position (or Apparent deviation)}} = \frac{1}{1 + \frac{G * w_n^2 * (s/a + 1)}{(s/b + 1) * (s^2 + 2 * z * w_n * s + w_n^2)}}$$

where:

- $G = 400$
- $b = (2 * \pi * 5600)$  in rad/s
- $a = (2 * \pi * 700)$  in rad/s
- $w_n = (2 * \pi * 40)$  in rad/s
- $z = (\text{zeta}) 0.2$  typ.
- $s = (j * 2 * \pi * \text{freq.})$  LaPlace Transform operator

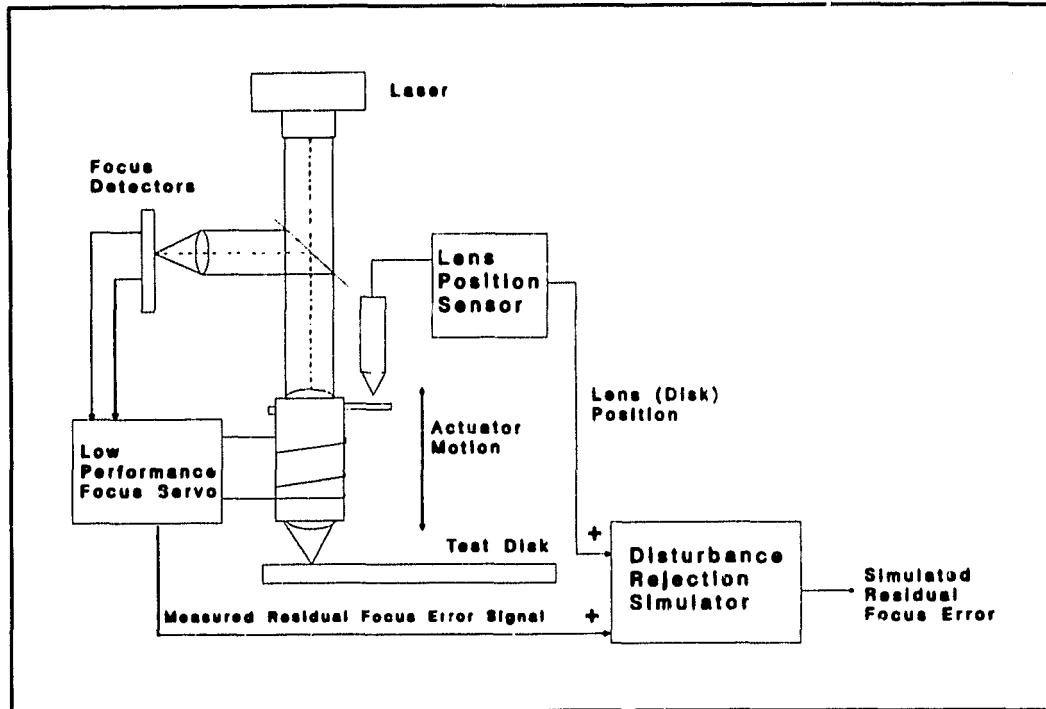

Figure 3.5.6. Residual focus error test system.

## 2) Calibration

- a) Employ a translation stage to move the measurement system relative to a suitable stationary reflector with a reflectance similar to that of the disk.
- b) With the measurement system positioned at the center of the focus error signal range, and the focus servo loop open, translate the measurement system a known distance within the linear range of the focus error signal detector to calibrate its output as a function of distance. The translation stage shall be accurate to better than  $.25\mu\text{m}$ .
- c) Return the measurement system to the center of the focus signal range and close the focus servo loop.

- d) Translate the measurement system a known amount to calibrate the lens position detection system as a function of distance.
- e) Replace the stationary reflector with the optical disk.

### 3) Test Conditions

Measurements shall be taken at three separate radii: 110 mm, 140 mm, and 170 mm.

### 4) Test Procedure.

Measure the peak-to-peak residual focus error.

## 3.5.7 Dynamic Radial Runout

### 1) Introduction

The dynamic radial runout shall be measured using the system shown in figure 3.5.7. For frequencies below the resonance of the radial actuator, the transfer function is constant and the actuator drive current is proportional to the radial position of the focused spot. Under these conditions, and when a servo system is used to maintain tracking, the actuator current is also proportional to the radial position of the tracking feature, provided the radial error signal is sufficiently small.

### 2) Calibration

#### a) Actuator Drive Current

Acquire tracking on a stationary disk. Vary the relative radial position of the head and the tracking feature with an accuracy of better than  $0.10\mu\text{m}$ . Record the actuator current as a function of relative position. The ratio of displacement to drive current is equal to  $K_1/K_2$ .

#### b) Tracking Error Signal

With the disk spinning, and the track servo open, calibrate the oscilloscope time base by measuring the track pitch as the distance between track crossings of the track error signal. Calibrate the timebase, in micrometers, by measuring the minimum time between track crossings. The track pitch is measured by the procedure in section 3.8.4. Calibrate the track error signal by obtaining the

voltage per unit distance ratio over the linear portion of the tracking s-curve.

### 3) Test Conditions

Measurements shall be taken at three separate radii: 110 mm, 140 mm, and 170 mm.

### 4) Test Procedure

- a) Obtain the actuator transfer function. Define a filter network with the same denominator as the actuator mass-spring-damper system (parasitic resonances are ignored).

#### Note:

For frequencies below the resonant frequency of the actuator this step can be ignored.

- b) While using a servo system to maintain tracking, measure the peak-to-peak radial actuator drive current during a revolution of the disk.
- c) The displacement equals the peak-to-peak actuator current times  $K_1/K_2$ , where  $K_1/K_2$  is determined by the calibration procedure
- d) When using this method, the maximum residual tracking error shall correspond to a displacement of less than 1% of the maximum runout specified in the appropriate media specifications document.



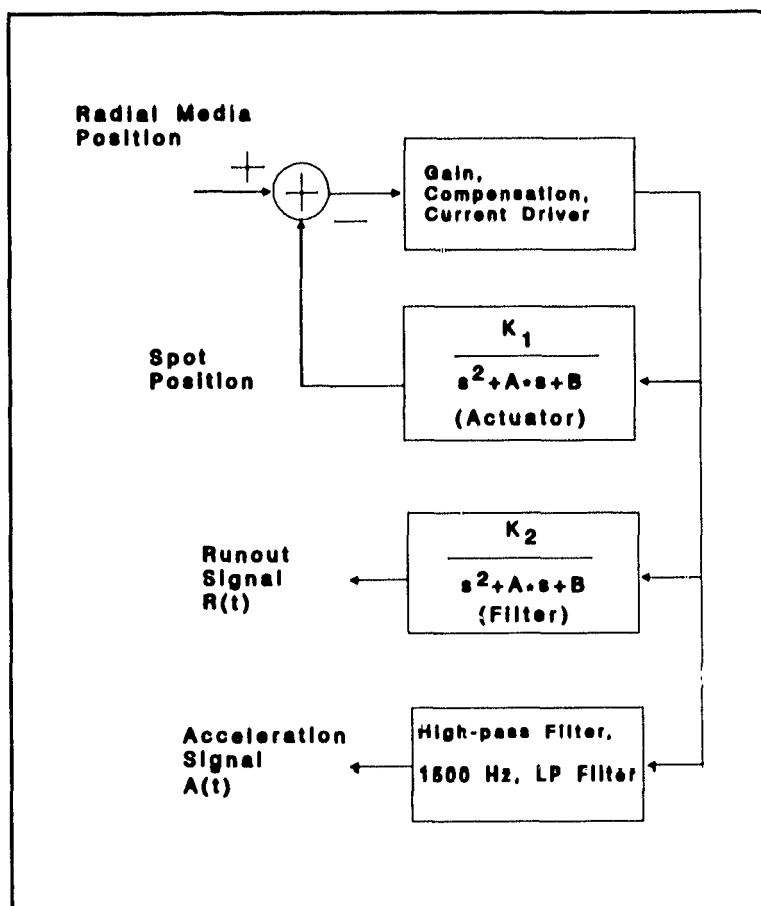

Figure 3.5.7. Dynamic radial runout block diagram.

### 3.5.8 Radial Acceleration

#### 1) Introduction

The actuator current is proportional to the acceleration of the lens, when considering frequencies above the natural frequency of the actuator.

#### 2) Calibration

Calibration of acceleration requires the determination of  $(K_1/K_2)$  as explained in section 3.5.7 in the calibration of dynamic radial runout.  $K_2$  is determined by inspection of the filter.

#### 3) Test Conditions

Measurements shall be taken at three separate radii: 110 mm, 140 mm, and 170 mm.

#### 4) Test procedure

- a) Choose a band-pass filter such that the lower frequency limit is 30 Hz, when taken in series with the natural frequency characteristics of the actuator. Unlike the upper specified frequency limit of 1500 Hz, the lower frequency limits are not critical (in fact, it may be shown that a disk must be significantly over the runout specification at 30 Hz to exceed the 30 Hz acceleration specification). The filter shall be a 4th-order maximally flat ("Butterworth") filter. Appendix C shows an example of this implementation.
- b) By expressing the constant K1 in terms of the measurable quantities K1/K2 and K2, the acceleration signal A(t) is related to the acceleration of the media, as follows: acceleration of the media = A(t) \* (K1/K2) \* K2.

### 3.5.9 Residual Tracking Error

#### 1) Introduction

The residual tracking error signal is the result of the tracking servo system's inability to perfectly reject disturbances. The sources of these disturbances are numerous and include dynamic radial runout, radial acceleration and vibration.

Residual tracking error shall be measured using the system shown in concept in figure 3.5.9. The closed loop tracking servo system shall have sufficient bandwidth such that the residual tracking error signal provides a linear, high resolution measurement of track position. A position sensor is employed to provide a high resolution measurement of the tracking lens position, therefore also the track. This sensor can be an interferometer, or an optical, capacitive, or electromagnetic device with bandwidth at least equal to that of the low performance servo system. When the residual tracking error signal is added to the lens position sensor signal, an exact measure of the position of the track is achieved. This track position signal is then processed by a digital or analog filter whose disturbance rejection transfer function is given in equation 3.5.9.:

$$\frac{\text{Residual tracking error}}{\text{Actual deviation}} = \frac{1}{1 + \frac{G * w_n^2 * (s/a + 1)}{(s/b + 1) * (s^2 + 2 * z * w_n * s + w_n^2)}}$$

where:

$$\begin{aligned} G &= 400 \\ b &= (2 * \pi * 5600) \text{ in rad/s} \\ a &= (2 * \pi * 700) \text{ in rad/s} \\ w_n &= (2 * \pi * 40) \text{ in rad/s} \\ z &= (\text{zeta}) 0.2 \text{ typ.} \\ s &= (j * 2 * \pi * \text{freq.}) \text{ LaPlace Transform operator} \end{aligned}$$

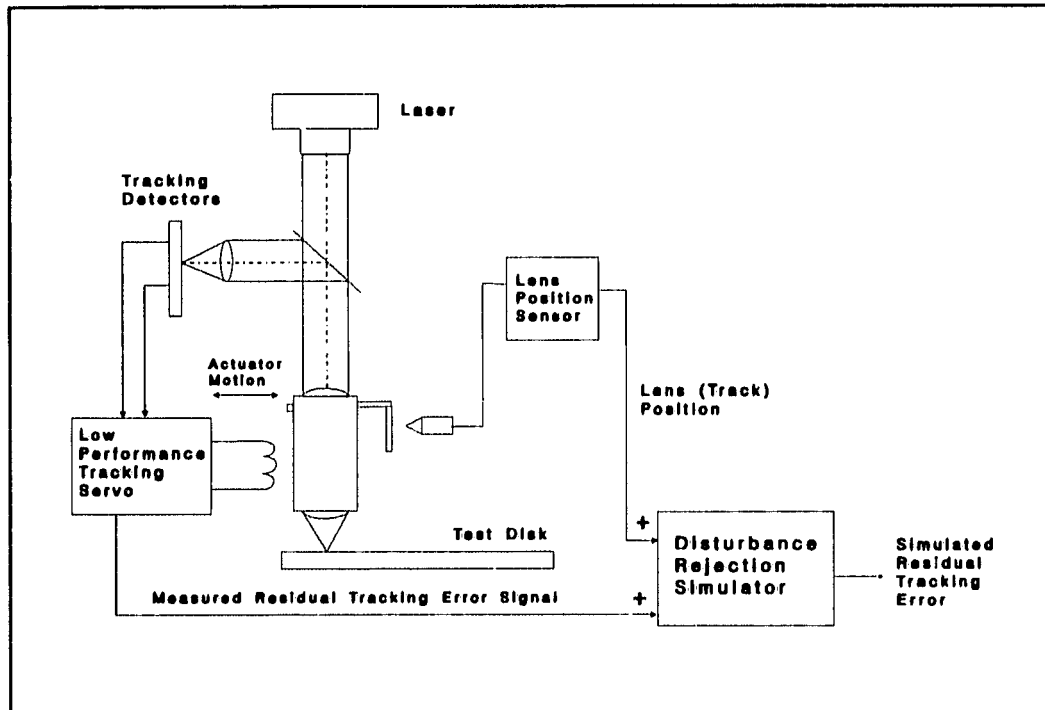

Figure 3.5.9. Residual tracking error test system.

## 2) Calibration

With the disk spinning, and the track servo open, calibrate the oscilloscope time base by measuring the track pitch as the distance between track crossings of the track error signal. Calibrate the timebase, in micrometers, by measuring the minimum time between track crossings. The track pitch is measured by the procedure in section 3.8.4. Calibrate the track error signal by obtaining the voltage per unit distance ratio over the linear portion of the tracking s-curve. Return the measurement system to the center of the tracking signal range and close the servo loop. Translate the measurement system a known amount to calibrate the lens position detection system as a function of distance.

### **3) Test Conditions**

Measurements shall be taken at three separate radii: 110 mm, 140 mm, and 170 mm.

### **4) Test Procedure**

Measure the peak-to-peak residual tracking error.

## **3.5.10 Droop**

### **1) Test Procedure**

Measure the DC level of the dynamic axial runout according to the test method described in section 3.5.4 at the inner and outer radius of the recording area. The droop is the difference between these two measurements.

## **3.5.11 Tilt**

### **1) Introduction**

The tilt of the disk surface shall be measured by using an auto collimator or similar apparatus as shown in figure 3.5.11. In general, a collimated light source is projected at a surface. When the surface is perpendicular to the optical path, the collimated beam is reflected on axis, and viewed relative to the reference axes in the viewport.

### **2) Calibration**

The system is calibrated by using a precision optical test flat on the spindle and a tilt stage. Tilt the test flat (or autocollimator) a known amount which can be calculated from the geometry of the set-up. Note the position of the reflected beam in the view port.

### **3) Test Procedure**

- a) Mount a precision optical test flat on the spindle and align the system such that the reflected beam is centered relative to the reference axes in the auto collimator view port.
- b) Mount the disk to be tested on the spindle in place of the precision optical test flat and note the relationship of the reflected beam to the reference axes.

- c) Slowly rotate the disk and translate the spindle (or auto collimator) to examine the tilt of the disk surface.

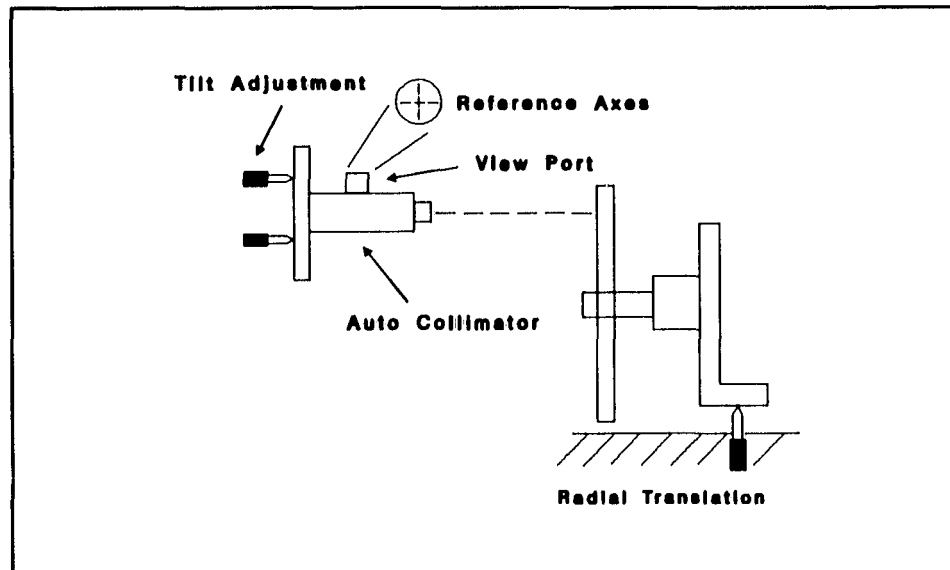

Figure 3.5.11. Tilt test setup.

## 3.6 Substrate Characteristics

### 3.6.1 Index of Refraction

The test of index of refraction is an accepted industry practice.

### 3.6.2 Double-pass Retardation

#### 1) Test Procedure

- a) The double-pass retardation (2) shall be measured by placing the sample in an optical isolator comprising a polarizer (P), a quarter wave plate (QWP) oriented at  $45^\circ$ , and a mirror (M). When a birefringent sample is placed in the optical path between the QWP and the mirror, the intensity of the reflected beam which leaks back through the polarizer is proportional to  $\sin^2(2\delta)$ . Figure 3.6.2. shows an optical layout for implementing this method with a transparent substrate. A laser beam passes through a beam splitter (BS), a polarizer, an oriented QWP, and is reflected by a mirror back to the photodetector (D1). By

tilting the substrate (S), measurements can be made at non-normal incidence.

b) The measurement shall be made at normal incidence and at an angle of  $30^\circ$ .

## 2) Calibration

Calibration of the signal can be accomplished by rotating the QWP a known angle away from  $45^\circ$  and measuring the detector output in the absence of a birefringent sample.

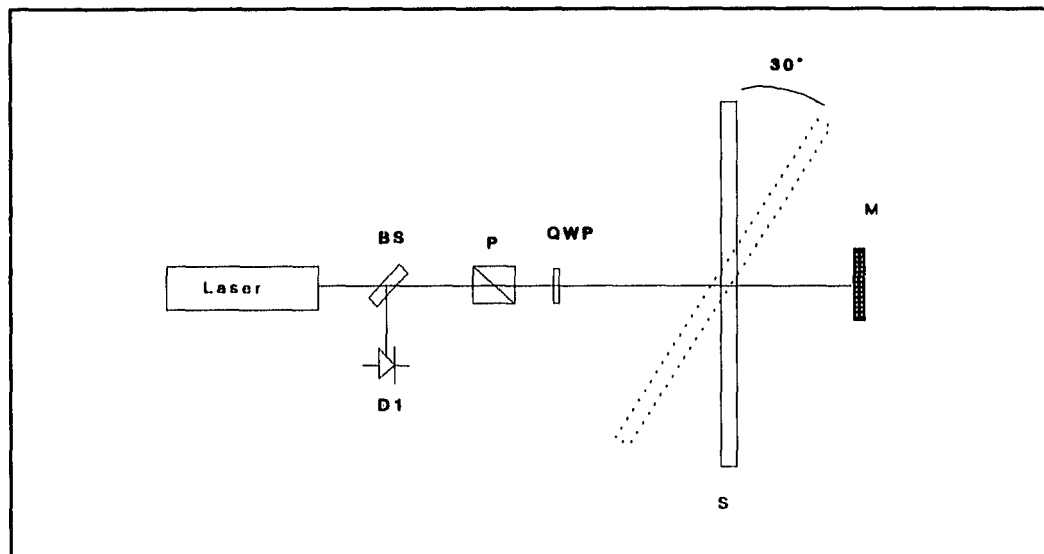

Figure 3.6.2. Double-pass retardation test setup.

## 3.6.3 Thickness

The test of thickness is an accepted industry practice.

## 3.7 Recording Layer Characteristics

### 3.7.1 Reflectance, Uniformity of Reflectance, and Rate of Change of Reflectance

#### 1) Introduction

The output of the DC coupled RF preamplifier or the sum of the preamplified focus

cell outputs, hereafter refer to as the output, will be used to measure baseline reflectance and uniformity of baseline reflectance.

## 2) Calibration.

To calibrate the system, measure the output to determine the DC voltage ( $V_o$ ) corresponding to 0% reflectance (i.e., laser off) and the voltage  $V_f$  from a sample of known reflectance ( $R_f$ ) at the testing wavelength, while in focus under the head. Then, for the disk sample with measured voltage  $V_d$ , the disk reflectance  $R_d$  is equal to:

$$R_d = \frac{R_f}{(V_f - V_o)} * (V_d - V_o)$$

## 3) Test Procedure

- a) Reflectance: Measure the output while focused over a smooth area of the rotating disk. This measurement shall be used to determine both the average level and uniformity of reflectance. The average reflectance is defined as the average of reflectance values measured at five radii equally spaced over the recordable area.
- b) Uniformity of reflectance: it is determined calculating the difference between the maximum and minimum values measured in any of the five equally spaced radii.
- c) Rate of change of reflectance: For each of the equally spaced radii, determine the difference between the maximum and minimum values of reflectance. The rate of change of reflectance (R/s) is the maximum of those five values multiplied by the rotation rate.

## 3.7.2 Resolution

### 1) Introduction

The measurements shall be performed at five radii equally spaced over the recordable area.

### 2) Test Procedure

- a) Record a 50% duty cycle tone at the optimum write power at the lowest and the highest frequency specified in the appropriate media specifications document.

- b) Measure the carrier amplitude in a 30 kHz bandwidth using a spectrum analyzer for both the high frequency and the low frequency carriers mentioned in paragraph (a). The resolution is defined as the ratio of the high frequency carrier amplitude to the low frequency carrier amplitude.

### 3.7.3 Imbalance of the Magneto-optic Signal

#### 1) Introduction

The measurements shall be performed at five radii equally spaced over the recordable area.

#### 2) Test Procedure

The imbalance of the magneto-optic signal shall be measured using the optical system described on appendix A. Imbalance is defined as the ratio of the maximum DC offset ( $\Delta$ ) of the readback signal to the average peak-to-peak signal amplitude along the track  $S_{ave}$ . (see figure 3.7.3.)

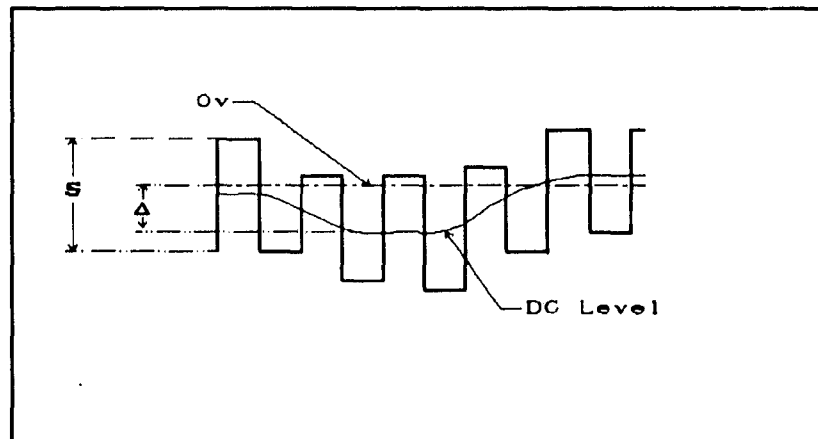

Figure 3.7.3. Imbalance of the magneto-optic signal.

### 3.7.4 Disk Retardation

#### 1) Introduction

The measurements shall be performed at five radii equally spaced over the recordable area.



This test method measures the phase difference between s and p polarization reflected from the disk. Such phase shifts are typically caused by birefringence in the substrate. Reflection from the active layers at non-normal incidence can also cause these phase shifts, independent of the magneto-optical effect. These effects are conventionally quantified as a retardation  $\delta$  in nm.

## 2) Test Instrument

Figure 3.7.4 shows the setup for the measurement of disk retardation. The measurement consists of placing the disk in an optical isolator consisting of a polarization beam splitter (PBS), a polarization analyzer (PA) and two quarter wave plates ( $QWP_1$  and  $QWP_2$ ) oriented at  $30^\circ$  with respect to the analyzer. The system is illuminated with collimated laser light of the wavelength given in table 2.4.1.

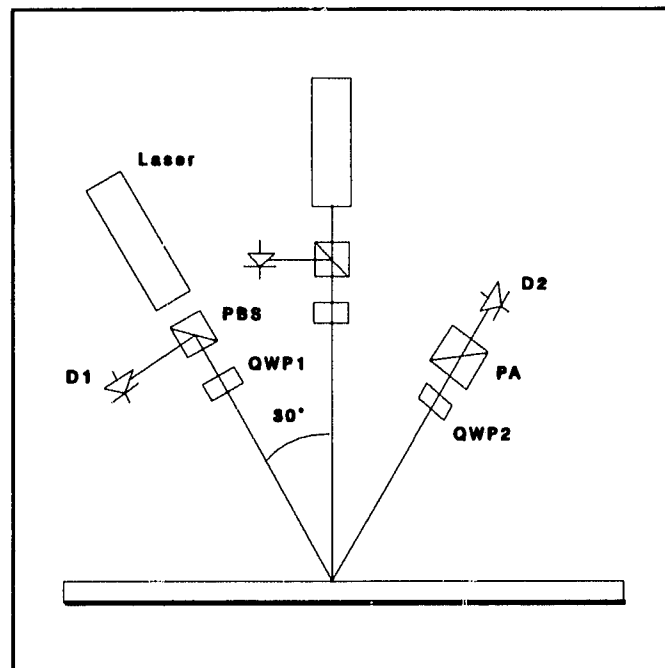

Figure 3.7.4. Disk retardation test instrument.

## 3) Calibration

Rotating  $QWP_1$  through a small angle  $\theta$  corresponds to introducing a phase shift  $\phi = 2\theta$  into the beam to detector  $D_2$  and  $\phi = 4\theta$  into the beam to  $D_1$ . The intensity of light on detectors  $D_1$  and  $D_2$  shall be measured as a function  $QWP_1$  angle  $\theta$ .

A plot of  $\delta = 2\theta$  times lambda over  $2\pi$  versus the intensity on  $D_2$  and a plot of  $\delta = 4\theta$  times lambda over  $2\pi$ , versus the intensity on  $D_1$  gives the calibration.

#### 4) Test Procedure

The measurement consists of determining the light intensity on detector  $D_1$  for normal incidence, and on detector  $D_2$  at an incidence angle of  $30^\circ$ . For a system with no phase difference between s and p light (and assuming perfect polarizers) no light should reach the detectors. These two measurements are converted to a retardation at normal incidence  $\delta_0$  and a retardation at  $30^\circ$ ,  $\delta_{30}$  using the instrument calibration.

### 3.7.5 Figure of Merit

#### 1) Introduction

The figure of merit  $F$ , is the product of  $R$ ,  $\sin \theta_k$  and  $\cos 2\epsilon_k$ , where  $R$  is the reflectance expressed as a percentage,  $\theta_k$  is the Kerr rotation and  $\epsilon_k$  is the ellipticity of the reflected beam.

The polarity of the figure of merit is defined to be negative for the written mark in an Fe-rich Fe-Tb alloy layer with the write magnetic field in the direction specified in section 2.4.3. The direction of Kerr rotation is counterclockwise as seen from the incident beam. The measurement shall be made with a direct measurement of  $\theta_k$  and  $\epsilon_k$  and with a conversion from the signal amplitude of written marks (see appendix B).

The figure of merit is, in practice, equal to the amplitude of the read signal from a recording at low frequency (in two dimensions). The written domains shall be substantially larger than the focal spot, so as to work in the low frequency region where the modulation transfer function of the optical system is one. This implies that a disk, rotating at 30Hz, a signal with a frequency between 10 kHz and 100 kHz has to be written on several consecutive tracks and in between those tracks.

Determination of the figure of merit using an optical system as shown in appendix A and with the characteristics as specified in section 2.4.1, will not measure media properties only but also the optical retardation of the optical system. Therefore the calibration of the optical system is needed with a conventional determination of the figure of merit by measuring the reflectance, Kerr rotation and ellipticity. This calibration can only be executed reliably on media with low coercivity.

## 2) Calibration

The optical test head shall be calibrated as follows:

- a) A test disk with negligible birefringence (glass) and low coercivity magneto-optical layer is used for conventional determination of reflectance  $R$ , Kerr rotation  $\theta_k$  and ellipticity  $\epsilon_k$ .
- b) Determine:  $F_L = R * \sin \theta_k * \cos 2\epsilon_k$
- c) Write on the same disk a test pattern as described above and read it back with the optical head resulting in signal amplitude  $V_L$ .

## 3) Test Procedure

Any other disk (high or low coercivity) can now be measured with the optical head using a similar test pattern, resulting in a signal amplitude  $V$ . The figure of merit of the disk now being tested is:  $F = F_L * V/V_L$ .

### 3.7.6 Narrow Band Signal-to-noise Ratio

#### 1) Test Conditions

- a) The measurement shall be made by writing marks at the minimum specified feature size, and at the optimum write power as determined by the test method in section 3.7.9.
- b) The measurements shall be taken on a spectrum analyzer with a 30 kHz resolution bandwidth (RBW).
- c) Measurements shall be taken at three separate radii: 110 mm, 140 mm, and 170 mm.

#### 2) Test Procedure

- a) Write a test track with a 50% duty cycle tone at the maximum frequency ( $f_c$ ) given in the appropriate media specifications document and at the proper rotational frequency to produce the minimum specified feature sizes.
- b) Read the test track and measure the signal level using a spectrum analyzer with a center frequency equal to the maximum specified frequency  $f_c$  and a resolution bandwidth of 30 kHz.

- c) Estimate the noise level by interpolating the average noise floor of the measurements between  $f_c - 7 * RBW$  and  $f_c + 7 * RBW$ .
- d) Calculate the narrow-band signal-to-noise ratio ( $SNR_{nb}$ ) using the following equation (see figure 3.7.6):

$$SNR_{nb} \text{ (dB)} = \text{signal power (dBm)} - \text{noise power (dBm)}$$

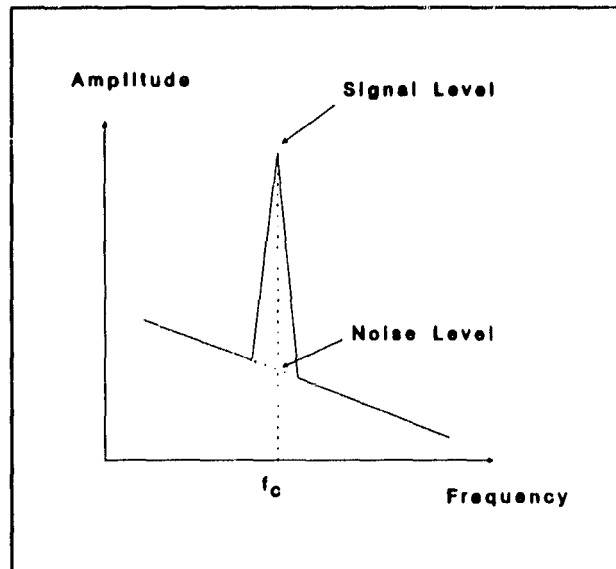

Figure 3.7.6. Amplitude versus frequency.

### 3.7.7 Crosstalk

#### 1) Introduction

The track-to-track crosstalk shall be determined by recording a set of three adjacent test tracks at a pitch specified in the appropriate media specifications document.

#### 2) Test Conditions

- a) Measurements shall be made on recordings written at the optimum write power as determined with the test method described in section 3.7.9.
- b) The measurements shall be taken on a spectrum analyzer with a 30 kHz

resolution bandwidth. Since there can be track pitch variations as a function of angle, it is necessary to measure the 6.5 MHz carrier and the 5 MHz signal power using a spectrum analyzer with zero frequency span capability. With the analyzer set up for external triggering (the trigger source is once-per-revolution index pulse), measure the worst case 5 MHz signal content and the corresponding 6.5 MHz signal content.

- c) Measurements shall be taken at three separate radii: 110 mm, 140 mm, and 170 mm.

### 3) Test Procedure

- a) Write a 6.25 MHz tone, at the optimum write power, on the center test track.
- b) Write the two tracks on each side of the center track at the track pitch (+ 0.1  $\mu\text{m}$ /- 0.0  $\mu\text{m}$ ), with a 5.0 MHz tone, at the optimum write power.
- c) Read the center test track with a spectrum analyzer with a resolution bandwidth of 30 kHz.
- d) The crosstalk is calculated by the following formula:

$$5.0 \text{ MHz signal power (dBm)} - 6.25 \text{ MHz signal power (dBm)}.$$

### 3.7.8 Ease of Erasure

#### 1) Test Condition

Measurements shall be taken at three separate radii: 110 mm, 140 mm, and 170 mm.

#### 2) Test Procedure

- a) Write a track under the write conditions given in section 2.4.3, and a frequency rate of 5.0 MHz.
- b) Read under the condition specified in section 2.4.2, using a spectrum analyzer with a center frequency  $f_c$  of 5.0 MHz and a resolution bandwidth of 30 kHz. Note the amplitude of the written marks.
- c) Erase the track under the conditions specified in section 2.4.4.

- d) Repeat the sequence (a) to (c) 1000 times.
- e) Repeat (a).
- f) Repeat (b); note the signal level of the written marks and of the noise at  $f_c$  (see figure 3.7.6).
- g) Repeat (c); note the residual level of the written marks.

### 3.7.9 Optimum Write Power

#### 1) Test Conditions

- a) The testing conditions shall conform to section 2.
- b) The actual write powers, linear velocity, write pulse durations, write/read and laser spot profiles must be known and corrected during performance of the tests.
- c) Time domain measurements shall be made using a time interval analyzer with at least 0.1 ns resolution. (ex: KODE-3100 or equivalent).
- d) Write pulse lengths shall be measured using equipment having rise and fall times of less than one nanosecond.
- e) Measurements shall be taken at three separate radii: 110 mm, 140 mm, and 170 mm.
- f) Time interval boundaries shall be determined by a threshold detection method.

#### 2) Test Procedure

- a) Erase the test track and adjacent tracks according to the conditions specified in section 2.4.4.
- b) Write sensitivity and write power range are measured by recording a series of tracks over a range of write powers that are expected to bracket the optimum write power.
- c) A 511-bit pseudo-random recording shall be made using the modulation code and data rate of the system for which this disk is intended. For example using a (1,7) code at a data rate of 22.5 Mbps produces the following pulse

durations: 59.26 ns, 88.89 ns, 118.52 ns, 148.15 ns, 177.78 ns, 207.41 ns, 237.04 ns, 266.67 ns, and 296.30 ns.

- d) The mark length errors for the minimum, maximum and medium mark length shall be measured by time interval analysis. The errors for each mark length shall be plotted versus the write power (see fig. 3.7.9). These errors are the average duration of the mark length from the desired length.
- e) The maximum absolute error curve shall be constructed by plotting the absolute value of the largest mark length error (from the three mark length error curves) versus each write power (see fig. 3.7.9).
- f) The optimum write power is the power at which the maximum absolute mark error curve is minimal (see fig. 3.7.9).
- g) The write power range is the range of write powers for which the maximum mean mark length error curve is less than or equal to 4.0 ns (see fig. 3.7.9).

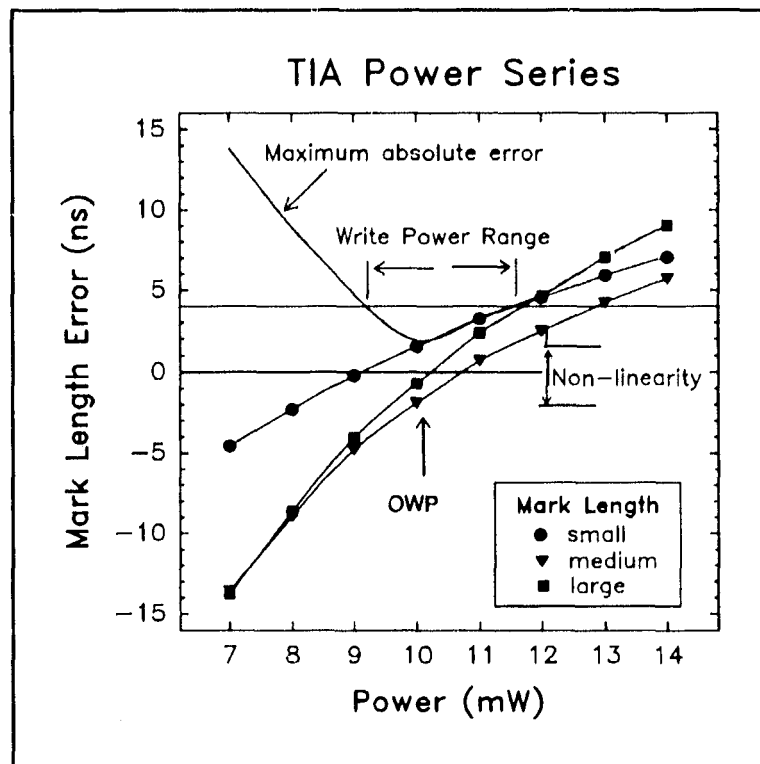

Figure 3.7.9. Mark length error versus write power.

### 3.7.10 Mark Uniformity

#### 1) Test Conditions

- a) The testing conditions shall conform to section 2.
- b) The actual write powers, linear velocity, write pulse durations, write/read and laser spot profiles must be known and corrected during performance of the tests.
- c) Time domain measurements shall be made using a time interval analyzer with at least 0.1 ns resolution. (ex: KODE-3100 or equivalent).
- d) Write pulse lengths shall be measured using equipment having rise and fall times of less than one nanosecond.
- e) Measurements shall be taken at three separate radii: 110 mm, 140 mm, and 170 mm.
- f) Time interval boundaries shall be determined by a threshold detection method.
- g) All recordings shall be made at the optimum write power as determined in section 3.7.9.

#### 2) Test Procedure

- a) Erase the test track and adjacent tracks according to the conditions specified in section 2.4.4.
- b) A 511-bit pseudo-random recording shall be made using the modulation code and data rate of the system for which this disk is intended. For example using a (1,7) code at a data rate of 22.5 Mbps produces the following pulse durations: 59.26 ns, 88.89 ns, 118.52 ns, 148.15 ns, 177.78 ns, 207.41 ns, 237.04 ns, 266.67 ns, and 296.30 ns.
- c) Measure a minimum of 1000 data to clock time intervals.
- d) Obtain the mean and standard deviation.



### 3.7.11 Raw Error Rate

#### 1) Introduction

This test method is used to compare the raw error rate (RER) of the media before, during, and after the environmental tests in section 3.1 through 3.4.

#### 2) Test Conditions

- a) The testing conditions shall conform to section 2.
- b) Measurements shall be made on recordings written at the optimum write power level as determined by the test method described in section 3.7.9.
- c) Measurements shall be taken at three separate radii: 110 mm (4.33 in), 140 mm (5.5 in), and 170 mm (6.69 in).
- d) Measurements shall be made with the setup shown in figure 3.7.11.

#### 3) Test Procedure

- a) Record a 5.0 MHz tone over a series of 5 tracks of the disk. This produces the following feature sizes at the three specified radii:

1.24  $\mu\text{m}$  at 110 mm, 1.58  $\mu\text{m}$  at 140 mm, and 1.92  $\mu\text{m}$  at 170 mm.

- b) Read the recording through the test setup shown in figure 3.7.11.
- c) Adjust the edge detector to produce 50% duty cycle transitions at the output with no data input.
- d) The error checker shall produce an error output by ex-oring the strobed output of the clock extractor with that output delayed one clock cycle.
- e) Following edge detection, strobe the data with a clock extracted using a phase-lock-loop (PLL) characterized by the following transfer function F(s):

$$F(s) = \frac{K * (s/b + 1)}{s * (s/a + 1) * (s/c + 1)}$$

where:  $K = 63,100,000$   
 $a = 2\pi * 160 \text{ rad/s}$   
 $b = 2\pi * 13,300 \text{ rad/s}$   
 $c = 2\pi * 800,000 \text{ rad/s}$

The PLL's free running frequency shall be adjusted to the output frequency, 10.0 MHz, as close as possible. Adjust the phase delay of the data so that the strobe point of the clock occurs at the midpoint of the bitcell.

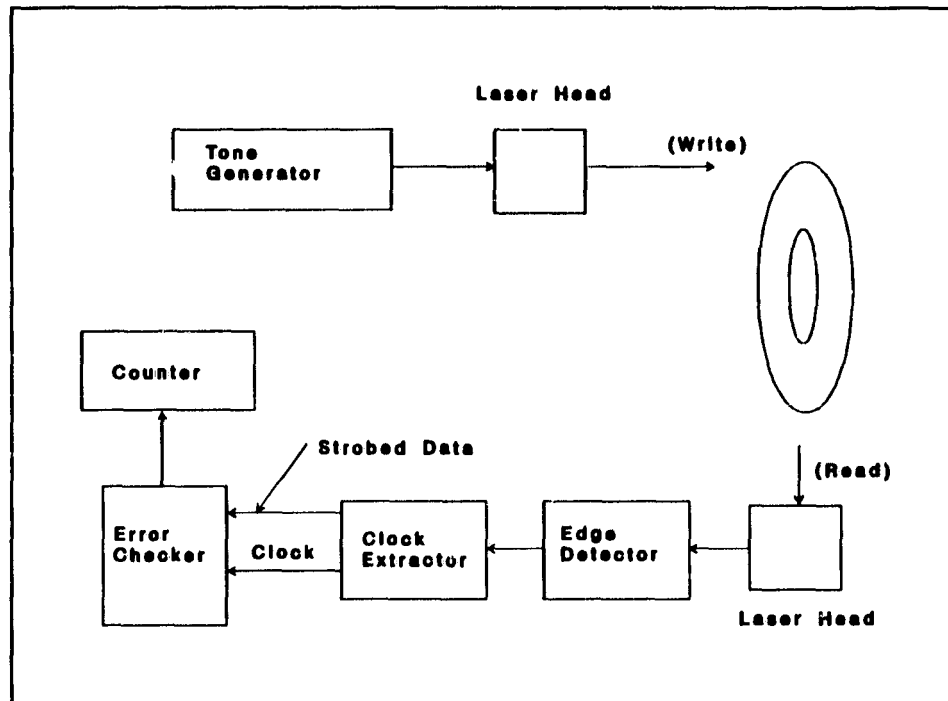

Figure 3.7.11. Raw error rate test setup.

### 3.8 Preformat Characteristics

The characteristics of the preformat pattern shall be measured using an optical head similar to the one depicted in appendix A. In the optical head, some of the light is directed to a photodetector (typically split as shown in fig. 3.8) for the purpose of detecting track servo signals and preformat data signals.

Characterization of the push pull, track crossing, and preformat data signals as well as the track pitch shall be measured using the optical head with the objective lens focused onto the disk and the signals defined as follows:

- $I_0$  : proportional to the reflected intensity from an ungrooved area.
- $I_1, I_2$  : signals from the two halves of the split detector.

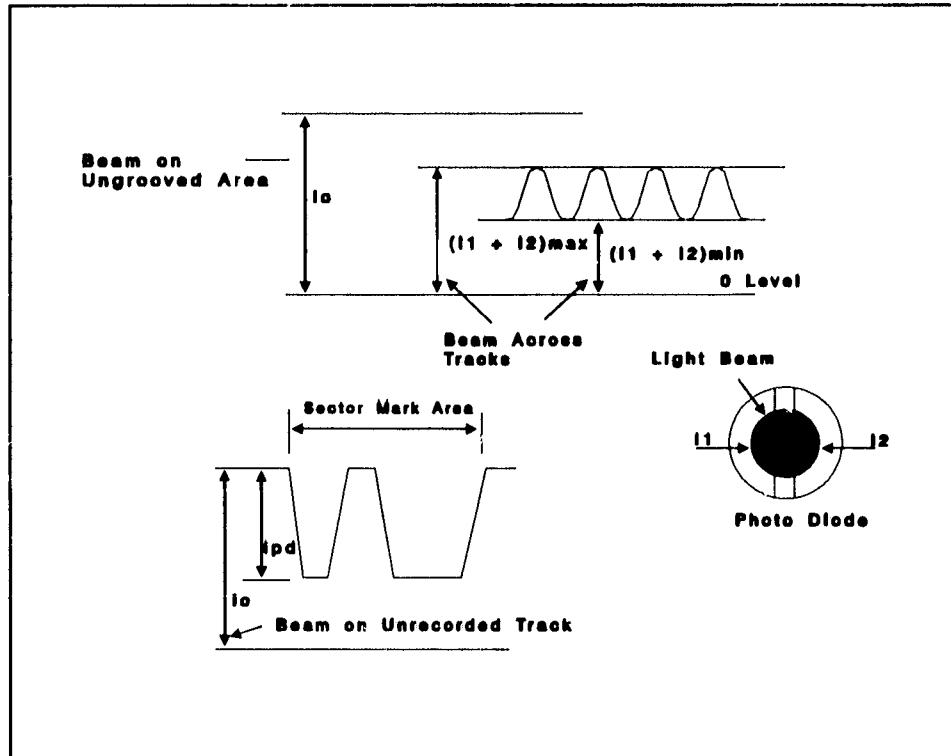

Figure 3.8. Preformat characteristics.

### 3.8.1 Push-pull Signal

With the disk spinning, track servo open and objective positioned over an ungrooved area, measure  $I_0 = (I_1 + I_2)_{max}$ . Then, position the objective over a grooved area and measure the magnitude of the track error signal  $I_1 - I_2$ . The push-pull ratio is defined as:

$$|I_1 - I_2|/I_0$$

where  $|I_1 - I_2|$  is the peak-to-peak amplitude of the track error signal.

### 3.8.2 Track Crossing Signal

With the disk spinning, the objective over a grooved area, and the track servo loop

open, measure the track sum signal  $(I_1 + I_2)$ .

The track cross ratio is defined as:

$$\{(I_1 + I_2)_{\max} - (I_1 + I_2)_{\min}\}/I_o$$

where  $(I_1 + I_2)_{\max}$  and  $(I_1 + I_2)_{\min}$  are shown in figure 3.8. The maximum track crossing signal is defined as:

$$(I_1 + I_2)_{\max}/I_o$$

### 3.8.3 Preformat Data Signal

With the objective lens positioned over a grooved area and the track servo loop closed, measure the track sum signal  $(I_1 + I_2)$ . As the head scans the track, the track sum signal modulates in accordance with the prerecorded sector/track identification. The preformat data signal ( $I_{pd}$ ) is defined as:

$$\{(I_1 + I_2)_{\max} - (I_1 + I_2)_{\min}\}/I_o$$

### 3.8.4 Track Pitch

#### 1) Test Procedure

- a) With the disk spinning and the track servo locking the objective on track, measure the displacement of the objective lens using the calibrated actuator drive current (see sec. 3.5.7, item 2: "calibration").
- b) Unlock the track servo, count the number of track crossings observed at the tracking error signal over one revolution.
- c) The track pitch is obtained by dividing the total displacement of the actuator measured in step (a), by the number of track crossings measured in step (b).

## 3.9 Media Lifetime

The methods for archival and shelf life assume that the errors are caused by defects which grow (or become more numerous) according to a first order rate equation, with

the rate determined by a single activation energy. Although it is unlikely that real degradation mechanisms follow this model precisely, this procedure is so defined as to provide a conservative estimate of disk life.

In an actual optical recording system, end-of-life is when the ECC can not accurately correct the errors caused by defects in the media (as well as from all other sources). A more realistic archival life test would be based on this criteria. However this requires that the characteristics of the ECC are known. This test method provides a simpler, system-independent test which is useful to qualify media and to compare the relative stability of different media.

### 3.9.1 Archival Life

#### 1) Introduction

Archival Life is the time after a disk is recorded that it can be read with a raw error rate (RER) not exceeding  $R_{eol}$ , where  $R_{eol}$  is specified in the appropriate media specification document.

#### 2) Test Conditions

- a) The test conditions shall conform to section 2.
- b) Measurements shall be made on recordings written at the optimum write power level as determined with the test method described in section 3.7.9.
- c) Measurements shall be made with the setup shown in figure 3.7.11.
- d) All disks used must conform to the specification for initial raw error rate,  $R_{ier}$ .

#### 3) Test Procedure

- a) Determine the number of transitions which must be recorded to determine the RER and be 95% sure the error in the measurement does not exceed  $0.1R_{ier}$ . This is given by  $n=384/R_{ier}$  (see appendix D).
- b) Record a 5.0 MHz tone at the radii of 110 mm, 140 mm, and 170 mm. The number of tracks recorded at each radius shall be such that the total number of transitions recorded in all three bands is at least the number of transitions determined in step a, or 5 tracks, whichever is greater.
- c) Determine the error rate using the procedure described in section 3.7.11,

subsections 3b through 3e. The initial error rate  $R_i$  is the total number of errors at all three radii divided by the total number of transitions recorded.

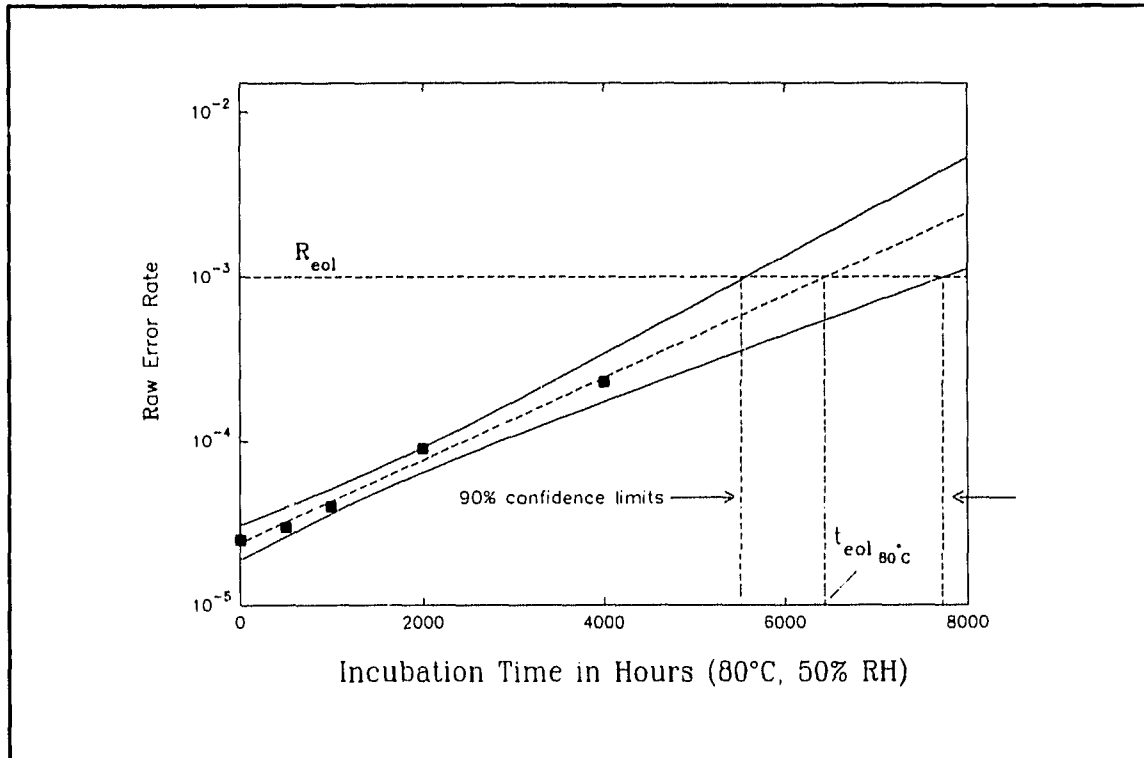

Figure 3.9.1.a. Incubation effect on the raw error rate.

- d) Repeat steps b-c on each side of at least 16 disks.
- e) Incubate at least 4 disks at each of the following conditions:  $T = 40^\circ C$ ,  $60^\circ C$ ,  $80^\circ C$ , and  $100^\circ C$ ; 50% relative humidity. The temperature and humidity must be ramped up from ambient conditions to chamber conditions and back so that condensation does not occur. Temperature and humidity ramps shall not exceed  $10^\circ C$  per hour. Prior to testing, all disks shall be allowed to equilibrate at the testing environment for 24 hours.
- f) After incubation times of 500, 1000, 2000, and 4000 hours, the disks shall be retested, and the error rate determined by using the procedure described in section 3.7.11, subsections 3b through 3e.
- g) For each disk surface, a straight line shall be fit to  $R_i$  and the error rates determined after each incubation time. From this fit the time  $t_{eol}$  at which the error rate exceeds  $R_{eol}$  is extrapolated, along with the 90% confidence limits as

shown in figure 3.9.1(a). The average  $\langle t_{eol} \rangle$  of the all surfaces at a given temperature, weighted by their 90% confidence intervals, is calculated along with the 90% confidence limit of the average. If any of the disks at any temperature should show no change in error rate with time, that condition shall be eliminated from further consideration. If less than three temperatures remain after those with no change in RER are eliminated, then additional temperatures ( $<100^\circ\text{C}>$ ) must be added to the test until 3 valid conditions are obtained.

- h) A plot of  $\log(\langle t_{eol} \rangle)$  versus  $1/T$  is formed as in figure 3.9.1 (b) and the data, weighted by their 90% confidence intervals, is fit to a straight line. From that line  $\langle t_{eol} \rangle$  at  $20^\circ\text{C}$  is extrapolated, along with its 90% confidence limit.
- i) Media is in conformance if the lower 90% confidence limit of  $\langle t_{eol} \rangle$  at  $20^\circ\text{C}$  exceeds the value given in the appropriate media specifications document.

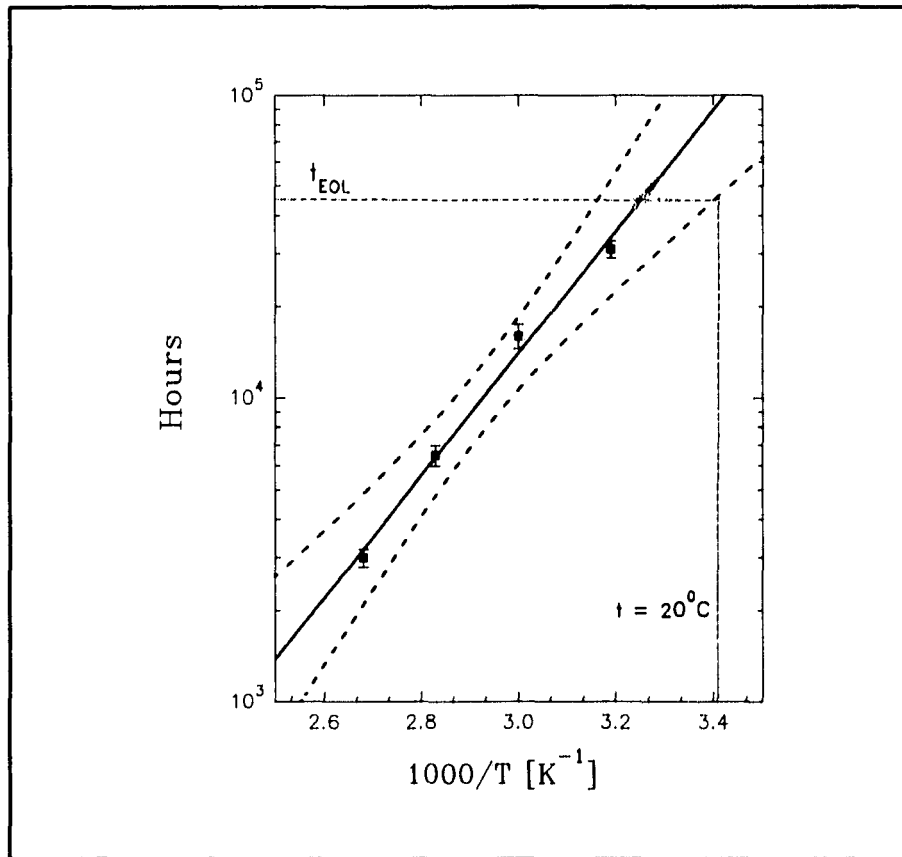

Figure 3.9.1.b. Extrapolated  $t_{EOL}$  value for the archival or shelf life test.

### 3.9.2 Shelf Life

#### 1) Introduction

Shelf Life is the time after manufacture that a disk can be recorded and read with a raw error rate not exceeding  $R_{eol}$ , where  $R_{eol}$  is specified in the appropriate media specifications document.

#### 2) Test Conditions

- a) The test conditions shall conform to section 2.
- b) Measurements shall be made on recordings written at the optimum write power level as determined with the test method described in section 3.7.9.
- c) Measurements shall be made with the setup shown in figure 3.7.11.
- d) All disks must conform to the specification for initial raw error rate  $R_{ier}$ .

#### 3) Test Procedure

- a) Determine the number of transitions which must be recorded to determine the RER and be 95% sure the error in the measurement does not exceed  $0.1 R_{ier}$ . This is given by (see app. D)  $n=384/R_{ier}$ .
- b) Record a 5.0 MHz tone at radii of 110 mm, 140 mm, and 170 mm. The number of tracks recorded at each radius shall be such that the total number of transitions recorded in all three bands is at least the number of bits determined in step a or 5 tracks, whichever is greater.
- c) Determine the error rate using the procedure described in section 3.7.11, subsections 3b through 3e. The initial error rate  $R_i$  is the total number of errors at all three radii divided by the total number of transitions written.
- d) Repeat steps b-c on each side of at least 16 disks.
- e) Incubate at least 4 disks at each of the following conditions:  $T = 40\text{ }^{\circ}\text{C}$ ,  $60\text{ }^{\circ}\text{C}$ ,  $80\text{ }^{\circ}\text{C}$ , and  $100\text{ }^{\circ}\text{C}$ ; 50% relative humidity. The temperature and relative humidity must be ramped up from ambient conditions to chamber conditions and back so that condensation does not occur. Temperature and humidity ramps shall not exceed  $10\text{ }^{\circ}\text{C}$  per hour. Disks shall be allowed to equilibrate at the testing environment for 25 hours prior to testing.



- f) After incubation times of 500, 1000 2000, 4000 hours, repeat steps b and c for each disk.
- g) For each disk surface, a straight line shall be fit to  $R_i$  and the error rates determined after each incubation time. From this fit the time  $t_{eol}$  at which the error rate exceeds  $R$  is extrapolate, along with the 90% confidence limits as shown in figure 3.9.1(a). The average  $\langle t_{eol} \rangle$  of the all surfaces at a given temperature, weighted by the 90% confidence intervals, is calculated along with the 90% confidence limit of the average. If any of the disks at any temperature should show no change in error rate with time, that condition shall be eliminated from further consideration. If less than three temperatures remain after those with no change in RER are eliminated, then additional temperatures ( $<100$  °C) must be added to the test until 3 valid conditions are obtained.
- h) A plot of  $\log (\langle t_{eol} \rangle)$  versus  $1/T$  is formed as shown in figure 3.9.1.b and the data, weighted by their 90% confidence intervals, is fit to a straight line. From that line  $\langle t_{eol} \rangle$  at 20 °C is extrapolated, along with its 90% confidence limit.
- i) Media is in conformance if the lower 90% confidence limit of  $\langle t_{eol} \rangle$  at 20 °C exceeds the value given in the appropriate section of the applicable specification document.

### 3.9.3 Read/Write/Erase Cycles

The disk shall be tested in accordance with the erase/write/read conditions outlined in section 2. The parameters listed in table 3.9.3 shall be measure before and after the specified number of erase/record cycles.

### 3.9.4 Extended Read

The disk shall be tested in accordance with the erase/write/read conditions outlined in section 2. The parameters listed in table 3.9.1 shall be tested before and after the specified number of read cycles.

**Table 3.9.3. Parameters for the read/write/erase cycles and extended read tests**

<b>Test</b>	<b>Section Number</b>
Narrow band	3.7.6
Signal-to-noise Ratio	
Crosstalk	3.7.7
Ease of Erasure	3.7.8
Optimum Write Power	3.7.9
Mark Uniformity	3.7.10
Raw Error Rate	3.7.11
Preformat Data Signal	3.8.3

# Chapter 4

## References

- [1] ISO 683-13 Heat Treatable Steels, Alloy Steels and Free-cutting Steels - Wrought Stainless Steels.
- [2] IEC 950 Safety of Information Technology Equipment Including Electrical Business Equipment.
- [3] NASA MSFC-HDBK-1674 "Compilation of TVS Data for Nonmetallic Materials."
- [4] SP-R-0022 "Vacuum Stability Requirements for Polymeric Materials for Spacecraft Applications."
- [5] ASTM E 595-84 "Test Method for Total Mass Loss and Collected Volatile Condensable Materials from Outgassing in a Vacuum Environment."
- [6] Mil-Std-810E "Environmental Test Methods and Engineering Guidelines."
- [7] NASA MSFC-HDBK-1674 "Compilation of TVS Data for Nonmetallic Materials."
- [8] SP-R-0022 "Vacuum Stability Requirements for Polymeric Materials for Spacecraft Applications."
- [9] Proposed American National Standard for Digital Information Interchange, 130 mm Rewritable Optical Disk Cartridge, Unrecorded Optical Disk Cartridge. X3B11/89-096, Part 1.
- [10] Proposed American National Standard for Digital Information Interchange, 130 mm Rewritable Optical Disk Cartridge, Recorded Format, Tracking and Servo Technique. X3B11/89-096, Part 2.

- [11] Proposed American National Standard, Unrecorded Optical Media Unit for Digital Information Interchange, 356 mm Optical Disk Cartridge - Write Once. X3B11/89-060R1, Part 1.
- [12] Proposed American National Standard, Recorded Optical Media Unit for Digital Information Interchange, 356 mm Optical Disk Cartridge - Write Once. X3B11/89-060R1, Part 2.
- [13] Proposed American National Standard, Test Methods for Media Characteristics of 130 mm Rewritable Optical Digital Data Disks. X3B11/89-006R1 (X3B11 Test Methods Project Group document).
- [14] Proposed American National Standard, Test Methods for Media Characteristics of 356 mm Optical Disk Cartridge - Write Once. X3B11/TM/89-005R1.
- [15] Proposed American National Standard, Test Methods for Media Characteristics of 356 mm Optical Disk Cartridge - Write Once. X3B11/89-162.
- [16] Specification of Track Deviations by a Standard Servo, ISO/IEC JTC1/SC23/WG2 N36.
- [17] Substrate Birefringence and Magneto-optic Readout: a Specification Strategy, A. Marchant, X3B11/88-049.
- [18] American National Standard for Information Systems - Magnetic Storage Disks with 14-inch (356 mm) diameter, ANSI X3.112-1984.

## Appendix A

### The Optical System Seen by any Beam for Measuring Write, Read and Erase Characteristics.

Figure A.1 shows the basic set-up of the optical system. Figure A.1 shows two basic optical systems. Either one shall be used. In Type A.1 detection, a nearly linearly polarized beam impinges upon the beam splitter J with the phase retarder I used to remove ellipticity. In Type A.2 detection, a nearly circularly polarized beam impinges upon the beam splitter J or the optional half-wave plate H.

- a) The linearly polarized beam entering beamsplitter E shall have an extinction ratio of less than 0.01. ). The extinction ratio of an optical beam is defined as the ratio of the minimum power over the maximum power observed behind a linear polarizer in the beam which is rotated over at least  $180^\circ$ .
- b1) The alignment of Type A.1 systems involve replacing the optical disk G with a reflective surface that does not change the polarization. Then, with the retarder removed, the polarizing beamsplitter J (or optional half-wave plate) shall be aligned to make the signal of  $K_1$  equal to that of  $K_2$ . The direction of polarization in this case is called the neutral direction. Then, with the optical disk and the phase retarder reinserted, a recorded track is read and the phase retarder adjusted to maximize the differential signal amplitude (channel 2).
- b2) The alignment of Type A.2 systems, involve replacing the optical disk with a reflective surface that does not change the polarization. The quarter-wave retarder is aligned to balance the  $K_1$  and  $K_2$  signals. Then, with the optical disk reinserted, a recorded track is read and the polarizing beam splitter J (or optional half-wave plate) is adjusted to maximize the differential signal amplitude (channel 2).

- c) Channel 1 is the sum of the photodiode signals, and is used for reading prerecorded marks. Channel 2 is the difference of the photodiode signals, and is used for reading user-written marks with the magneto-optical effect of Kerr rotation.

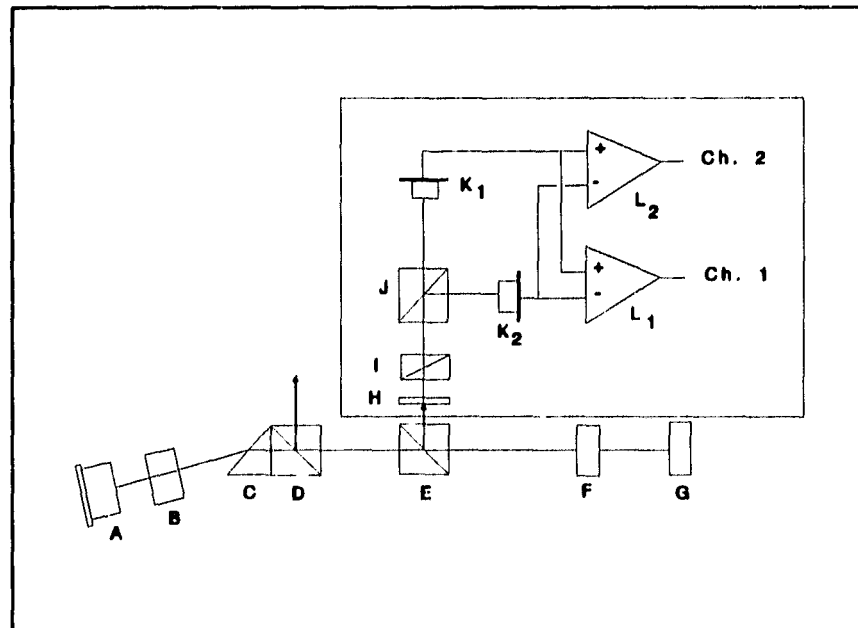

Figure A.1. The optical system seen by any beam for measuring write, read, and erase characteristics for Type A.1 detection.

- |     |   |              |   |
|-----|---|--------------|---|
| A : | laser diode                                 | G :          | optical disk  |
| B : | collimator lens                             | H :          | optional half-wave plate                                    |
| C : | optional shaping prism                      | I :          | Phase retarder  |
| D : | beamsplitter (BS)                           | J :          | polarizing beamsplitter (PBS,<br>p-s ratio larger than 500) |
| E : | partially polarizing<br>beamsplitter (PPBS) | $K_1, K_2$ : | photodiodes   |
| F : | objective lens                              | $L_1, L_2$ : | DC-coupled amplifier  |

**Note:**

In figure A.1., for Type A.2 detection, H and I are interchanged.

## Appendix B

### Definition of Write Pulse Shape

Figure B.1, shows the write pulse shape. In this figure, RP is the read power, and WP is the write power.

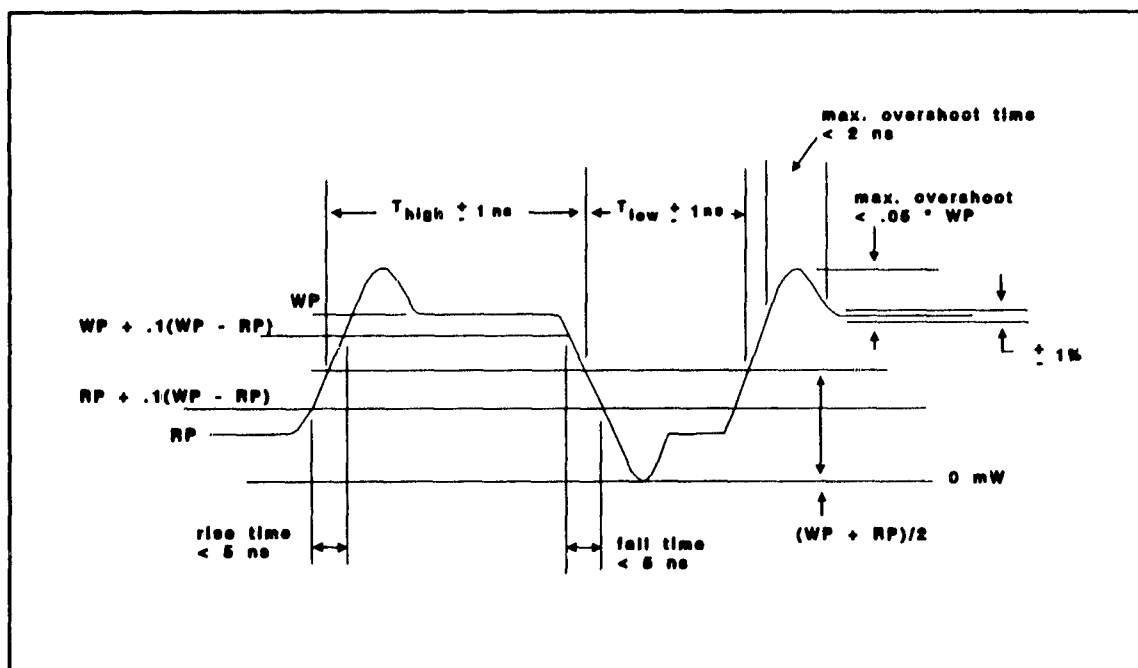

Figure B.1. Definition of write pulse shape.

# Appendix C

## 1500 Hz Filter Implementation

Figure C.1 shows an implementation of a 4th-order maximally flat ("Butterworth") filter with a  $F_c$  of 1500 Hz.

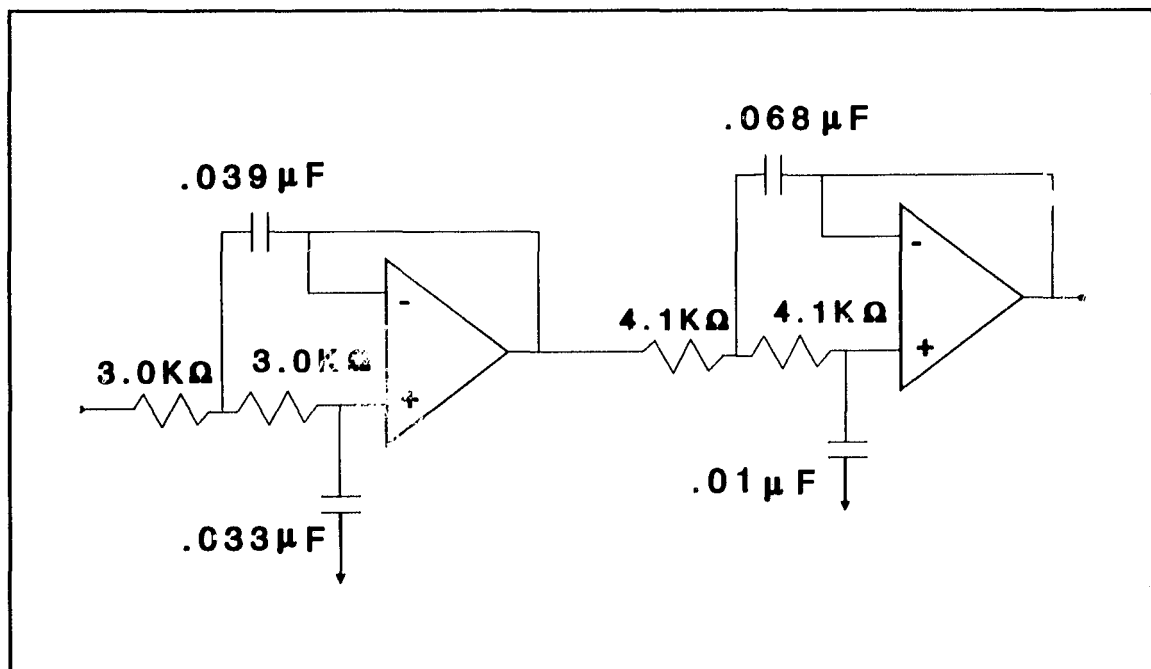

Figure C.1. 1500 Hz filter implementation.



## Appendix D

### Determination of the Number of Transitions Required for the Raw Error Rate Testing

If a large number  $n$  transitions are sampled and  $n_e$  are in error then an estimate of the fraction in error (the RER) is  $p = n_e/n$  with a standard deviation of approximately  $(p(1-p)/n)^{1/2}$ . Then the  $100(1-\alpha)\%$  confidence interval is  $d = z_{\alpha/2} * (p(1-p)/n)^{1/2}$ , where the area of the standard normal distribution to the right of  $z_{\alpha/2}$  is  $\alpha/2$ .

Solving for  $n$ :  $n = p(1-p) * (z_{\alpha/2} / d)^2$ .

Typical initial error rates  $R_{ier}$  are on the order of  $10^{-5}$ , so  $p(1-p)$  is approximately  $p = R_{ier}$ . For a 95% confidence interval,  $z_{\alpha/2} = 1.96$ .

For the measurement error to be  $<0.1R_{ier}$ ,

then  $d = 0.1R_{ier}$  and  $n = 384/R_{ier}$ .

# Appendix E

## Working Group Participants

**Joe Cinelli**  
GE Aerospace,  
Government Communications  
Systems Department  
Delaware & Cooper Sts., Mail Stop: 13-3-1  
Camden, NJ 08102

**Jathan Edwards**  
3M Co.  
Bldg. 201-1N-34  
St. Paul, MN 55144

**Scott A. Gerger**  
Eastman Kodak Company  
Mass Memory Research Labs.  
460 Buffalo Rd.  
Rochester, NY 14652-3801

**Fred Haritatos**  
Rome Air Development Center  
RADC/IRAP  
Griffiss AFB, NY 13441

**Taras Kozak**  
GE Aerospace  
Government Communications  
Systems Department  
Delaware & Cooper Sts., Mail Stop: 13-3-1  
Camden, NJ 08102

**Fernando L. Podio**  
NIST  
National Computer Systems  
Laboratory  
Bldg. 225, Room A-61,  
Gaithersburg, MD 20899

**Pam Rinsland**  
NASA  
Langley Research Center  
Hampton, VA  
Mail Code: 488

**Dr. Thomas A. Shull**  
NASA  
Head, Electronics Branch  
Flight Electronic Division  
Langley Research Center, Mail Code: 488  
Hampton, VA 23665-5225

**John Stadler**  
NASA  
Langley Research Center  
Hampton, VA 23665  
Mail Code: 433

**Douglas G. Stinson**  
Eastman Kodak Co.  
Mass Memory R&D  
Bldg. 800, Floor 1 KPG  
Rochester, NY 14652-3801

NIST-114A REV. 3-80)	<b>U.S. DEPARTMENT OF COMMERCE</b> <b>NATIONAL INSTITUTE OF STANDARDS AND TECHNOLOGY</b>	<b>1. PUBLICATION OR REPORT NUMBER</b> NIST/SP-500/191
<b>BIBLIOGRAPHIC DATA SHEET</b>		<b>2. PERFORMING ORGANIZATION REPORT NUMBER</b>
<b>TITLE AND SUBTITLE</b> Test Methods for Optical Disk Media Characteristics (for 356 mm Ruggedized Magneto-Optic Media)		<b>3. PUBLICATION DATE</b> September 1991
<b>AUTHOR(S)</b> Fernando L. Podio, editor		
<b>PERFORMING ORGANIZATION (IF JOINT OR OTHER THAN NIST, SEE INSTRUCTIONS)</b> U.S. DEPARTMENT OF COMMERCE NATIONAL INSTITUTE OF STANDARDS AND TECHNOLOGY GAITHERSBURG, MD 20899	<b>7. CONTRACT/GRANT NUMBER</b>	<b>8. TYPE OF REPORT AND PERIOD COVERED</b> Final
<b>SPONSORING ORGANIZATION NAME AND COMPLETE ADDRESS (STREET, CITY, STATE, ZIP)</b> National Aeronautics and Space Administration Langley Research Center Hampton, VA 23665-5225		
NIST CATEGORY # 160		
<b>SUPPLEMENTARY NOTES</b>		
<b>ABSTRACT (A 200-WORD OR LESS FACTUAL SUMMARY OF MOST SIGNIFICANT INFORMATION. IF DOCUMENT INCLUDES A SIGNIFICANT BIBLIOGRAPHY OR LITERATURE SURVEY, MENTION IT HERE.)</b> Standard test methods for computer storage media characteristics are essential and allow for conformance verification to media interchange standards. Test methods are also needed to develop procedures which would allow for repeatability of results among different industry and U.S. Government sites. The test procedures documented in this publication reflect the work done by the NIST/NASA Working Group for the Development of Test Methods and Specifications for 356 mm Ruggedized Rewritable Media. The test methods were developed for 356 mm two-sided laminated glass substrate with a magneto-optic active layer media technology. These test methods may be used for testing other media types, but in each case their applicability must be evaluated. Test methods are included for a series of different media characteristics including: operational, non-operational, and storage environments, mechanical and physical characteristics, and substrate, recording layer, and preformat characteristics. Tests for environmental qualification and media lifetimes are also included. The test methods include testing conditions, testing procedures, a description of the testing setup, and the required calibration procedures.		
<b>KEY WORDS (6 TO 12 ENTRIES; ALPHABETICAL ORDER; CAPITALIZE ONLY PROPER NAMES; AND SEPARATE KEY WORDS BY SEMICOLONS)</b> erasable media; magneto-optic media; media lifetime; optical disk media; ruggedized optical media; test methods		
<b>AVAILABILITY</b> <input checked="" type="checkbox"/> UNLIMITED FOR OFFICIAL DISTRIBUTION. DO NOT RELEASE TO NATIONAL TECHNICAL INFORMATION SERVICE (NTIS). <input checked="" type="checkbox"/> ORDER FROM SUPERINTENDENT OF DOCUMENTS, U.S. GOVERNMENT PRINTING OFFICE, WASHINGTON, DC 20402. <input checked="" type="checkbox"/> ORDER FROM NATIONAL TECHNICAL INFORMATION SERVICE (NTIS), SPRINGFIELD, VA 22161.	<b>14. NUMBER OF PRINTED PAGES</b> 74	<b>15. PRICE</b>

**ANNOUNCEMENT OF NEW PUBLICATIONS ON  
COMPUTER SYSTEMS TECHNOLOGY**

**Superintendent of Documents  
Government Printing Office  
Washington, DC 20402**

**Dear Sir:**

**Please add my name to the announcement list of new publications to be issued in  
the series: National Institute of Standards and Technology Special Publication 500-**

**Name** \_\_\_\_\_

**Company** \_\_\_\_\_

**Address** \_\_\_\_\_

**City** \_\_\_\_\_ **State** \_\_\_\_\_ **Zip Code** \_\_\_\_\_

**(Notification key N-503)**

# *NIST* Technical Publications

## *Periodical*

---

**Journal of Research of the National Institute of Standards and Technology**—Reports NIST research and development in those disciplines of the physical and engineering sciences in which the Institute is active. These include physics, chemistry, engineering, mathematics, and computer sciences.

Papers cover a broad range of subjects, with major emphasis on measurement methodology and the basic technology underlying standardization. Also included from time to time are survey articles on topics closely related to the Institute's technical and scientific programs. Issued six times a year.

## *Nonperiodicals*

---

**Monographs**—Major contributions to the technical literature on various subjects related to the Institute's scientific and technical activities.

**Handbooks**—Recommended codes of engineering and industrial practice (including safety codes) developed in cooperation with interested industries, professional organizations, and regulatory bodies.

**Special Publications**—Include proceedings of conferences sponsored by NIST, NIST annual reports, and other special publications appropriate to this grouping such as wall charts, pocket cards, and bibliographies.

**Applied Mathematics Series**—Mathematical tables, manuals, and studies of special interest to physicists, engineers, chemists, biologists, mathematicians, computer programmers, and others engaged in scientific and technical work.

**National Standard Reference Data Series**—Provides quantitative data on the physical and chemical properties of materials, compiled from the world's literature and critically evaluated. Developed under a worldwide program coordinated by NIST under the authority of the National Standard Data Act (Public Law 90-396). NOTE: The Journal of Physical and Chemical Reference Data (JPCRD) is published bi-monthly for NIST by the American Chemical Society (ACS) and the American Institute of Physics (AIP). Subscriptions, reprints, and supplements are available from ACS, 1155 Sixteenth St., NW., Washington, DC 20056.

**Building Science Series**—Disseminates technical information developed at the Institute on building materials, components, systems, and whole structures. The series presents research results, test methods, and performance criteria related to the structural and environmental functions and the durability and safety characteristics of building elements and systems.

**Technical Notes**—Studies or reports which are complete in themselves but restrictive in their treatment of a subject. Analogous to monographs but not so comprehensive in scope or definitive in treatment of the subject area. Often serve as a vehicle for final reports of work performed at NIST under the sponsorship of other government agencies.

**Voluntary Product Standards**—Developed under procedures published by the Department of Commerce in Part 10, Title 15, of the Code of Federal Regulations. The standards establish nationally recognized requirements for products, and provide all concerned interests with a basis for common understanding of the characteristics of the products. NIST administers this program as a supplement to the activities of the private sector standardizing organizations.

**Consumer Information Series**—Practical information, based on NIST research and experience, covering areas of interest to the consumer. Easily understandable language and illustrations provide useful background knowledge for shopping in today's technological marketplace.

Order the **above** NIST publications from: Superintendent of Documents, Government Printing Office, Washington, DC 20402.

Order the **following** NIST publications—FIPS and NISTIRs—from the National Technical Information Service, Springfield, VA 22161.

**Federal Information Processing Standards Publications (FIPS PUB)**—Publications in this series collectively constitute the Federal Information Processing Standards Register. The Register serves as the official source of information in the Federal Government regarding standards issued by NIST pursuant to the Federal Property and Administrative Services Act of 1949 as amended, Public Law 89-306 (79 Stat. 1127), and as implemented by Executive Order 11717 (38 FR 12315, dated May 11, 1973) and Part 6 of Title 15 CFR (Code of Federal Regulations).

**NIST Interagency Reports (NISTIR)**—A special series of interim or final reports on work performed by NIST for outside sponsors (both government and non-government). In general, initial distribution is handled by the sponsor; public distribution is by the National Technical Information Service, Springfield, VA 22161, in paper copy or microfiche form.