

N 9 2 - 2 1 6 3 9

MICROWAVE CONDUCTIVITY OF LASER ABLATED $\text{YBa}_2\text{Cu}_3\text{O}_{7-\delta}$ SUPERCONDUCTING FILMS AND ITS RELATION TO MICROSTRIP TRANSMISSION LINE PERFORMANCE

K. B. Bhasin, J. D. Warner, C. M. Choresy*, B. T. Ebihara, R. R. Romanofsky and V. O. Heinen

National Aeronautics and Space Administration
Lewis Research Center, Cleveland OH., 44135* Sverdrup Technology/LeRC Group
Cleveland OH., 44142F. A. Miranda and W. L. Gordon
Department of Physics
Case Western Reserve University, Cleveland OH., 44106

ABSTRACT

We report on the values of the microwave conductivity in the normal (σ_N) and superconducting ($\sigma^* = \sigma_1 - j\sigma_2$) states of two laser ablated $\text{YBa}_2\text{Cu}_3\text{O}_{7-\delta}$ thin films at 35 GHz, in the temperature range from 20 to 300 K. The films (0.7 and 0.4 μm) were deposited on LaAlO_3 by laser ablation. The conductivity was obtained from the microwave power transmitted through the films and assuming a two fluid model. Values of $\sigma_N \sim 2.3 \times 10^5$ S/m at room temperature for both films, and of $\sigma_1 \sim 6.3 \times 10^5$ and 4.6×10^5 S/m at temperatures around 80 K were obtained for the 0.7 and 0.4 μm films respectively. For σ_2 values of 4.9×10^6 and 5.4×10^6 S/m were obtained for the 0.7 and 0.4 μm films at 80 K. The expected conductor losses and Q-factor of a superconducting ring resonator were calculated using these conductivity values. The theoretical values were then compared with the experimental results obtained for a resonator fabricated from one of these films.

The discovery of high transition temperature (T_c) superconductors has raised the possibility of a new class of microwave and millimeter wave devices operating at temperatures considerably higher than liquid helium temperatures. Therefore, materials properties such as microwave conductivity (σ), critical current density (J_c), microwave surface resistance (R_s), transport anisotropies, thermal expansion, and others have to be well characterized and understood. To date, measurements of R_s at microwave and millimeter wave frequencies and of J_c of $\text{YBa}_2\text{Cu}_3\text{O}_{7-\delta}$ superconducting oxides have been very abundant.¹⁻³ Nevertheless, reports on the microwave conductivity of these new oxides have been rare.^{4,5} The need for more data on the microwave conductivity of these oxides arises from the fact that knowledge of this parameter provides a way to calculate other relevant properties such as the normal skin depth (δ_n) and the magnetic penetration depth in the superconducting state (λ_s). From the practical application point of view, it provides valuable aid for the design of microwave devices and circuits, based on superconducting microstrip lines.^{6,7}

In this paper we report on the microwave conductivity of laser ablated $\text{YBa}_2\text{Cu}_3\text{O}_{7-\delta}$ superconducting thin films at 35 GHz in the temperature range from 20 to 300 K. The values of the conductivities were obtained from the microwave power transmitted through the film, assuming a two-fluid model. The expected conductor losses and Q-factor of a superconducting ring resonator were calculated using

these conductivity values. The theoretical values were then compared with the experimental results obtained for a resonator fabricated from one of these films.

The pulsed laser ablation technique is similar to that reported by other researchers.^{8,9} The deposition was performed at a substrate temperature of 750° C at an ambient oxygen pressure of 170 mtorr. The laser wavelength was 248 nm, the pulse length and rate were 20 to 30 ns and 4 pps respectively. During this process the distance between the target and the sample was kept at 7.5 cm and the laser fluence on the target was maintained at 2.0 J/cm² per pulse. The laser beam was continually scanned 1 cm across the target using an external lens on a translator. When the deposition was finished, the oxygen pressure was raised to 1 atm and the temperature was lowered to 450° C at a rate of 2° C/min. The temperature was held at 450° C for two hrs before it was lowered to 250° C at the same rate already mentioned. Finally, the heater power was turned off and the sample was allowed to cool to 40° C or less before it was removed from the chamber. This deposition process is explained in more detail in reference 10.

Two YBa₂Cu₃O_{7-δ} superconducting thin films, deposited by laser ablation on LaAlO₃, have been considered in this study. The films' thicknesses were 0.7 and 0.4 μm respectively. LaAlO₃ is a convenient substrate because of its perovskite crystal structure and its lattice constant of a=5.357 Å which match very well with the lattice constant of the YBa₂Cu₃O_{7-δ} superconducting oxide. Also, its low dielectric constant (~22) makes it suitable for microwave device applications. The films were analyzed by X-ray diffraction, dc resistance versus temperature measurements and scanning electron microscope (SEM). Transition temperatures (T_c, R=0) of 89.7 and 86.0 K were measured for the 0.7 and 0.4 μm thin films respectively. The dc resistance versus temperature curves are shown in fig.1. The X-ray diffraction pattern revealed that both films are single phased with a strong c-axis orientation. Both films exhibit a very smooth surface as observed from scanning electron micrographs. A grain size of ≈½ μm was observed for both films.

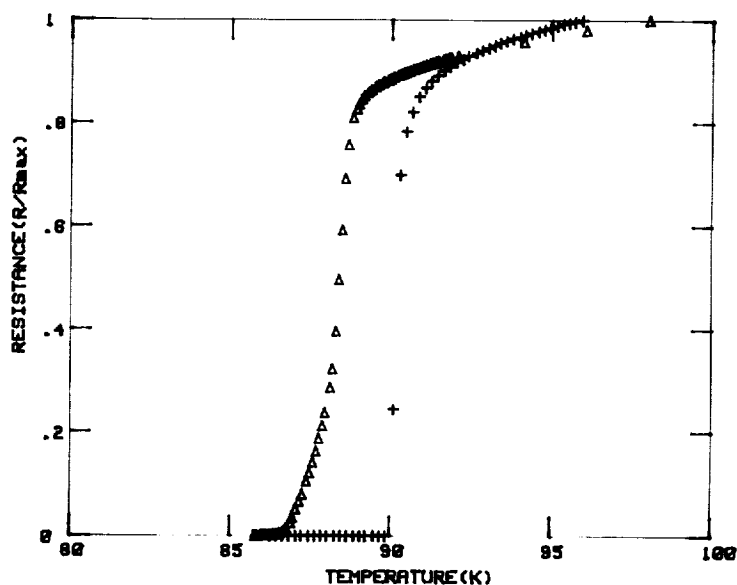

FIGURE 1. Dc resistance versus temperature of 0.7 μm (+) and 0.4 μm (Δ) laser ablated YBa₂Cu₃O_{7-δ} thin films on LaAlO₃.

The power transmission measurements were performed using an HP-8510 network analyzer connected to a helium gas closed cycle refrigerator by Ka-band (26.5 to 40.0 GHz) waveguides. All the measurements were taken under vacuum ($<10^{-3}$ torr) in a custom designed vacuum chamber. Inside the vacuum chamber the sample was clamped between two waveguide flanges mounted on top of the cold finger of the refrigerator. The waveguides were made of stainless steel to minimize heat conduction from the external waveguide arrangement and their inner surfaces were gold-plated to reduce microwave energy losses. Vacuum was maintained at the waveguide feedthroughs by means of 'O' rings and mica sealing windows. The temperature of the sample was monitored using silicon diode sensors mounted on the waveguide flanges supporting the sample. All the measurements were taken during sample cooling.

The measured temperature dependence of the transmitted power through the sample for both films under consideration is shown in fig.2 . Note that for the $0.7 \mu\text{m}$ film both, the onset temperature for the transition from the normal to the superconducting state ($\sim 91 \text{ K}$) and the transition temperature T_c (89.7 K), are clearly observed in this measurement. For the thinner film a sharp drop in transmitted power is observed below the onset temperature, with an attenuation of approximately 20 dB at temperatures around 80 K. The most relevant feature of the power versus temperature curve for this film is the sudden increase in transmitted power at temperatures below 80 K. This feature is an indication of the formation of a leakage source (micro-crack or pinhole) which broadens as the temperature decreases allowing more power to leak through the film. At temperatures below 50 K the amount of power leaking through the film reaches a constant value suggesting no significant variation of the leakage sources as a function of temperature in this temperature region.

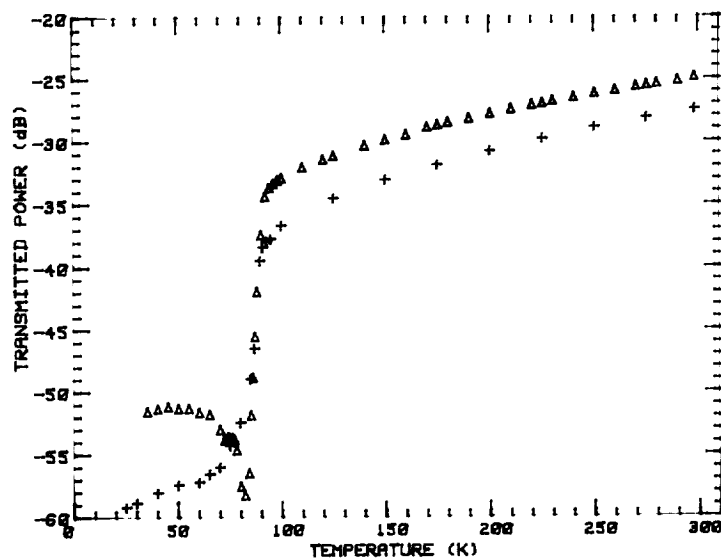

FIGURE 2. Transmitted power versus temperature of $0.7 \mu\text{m}$ (+) and a $0.4 \mu\text{m}$ (Δ) laser ablated $\text{YBa}_2\text{Cu}_3\text{O}_{7-6}$ thin films on LaAlO_3 at 35 GHz.

The normal state microwave conductivity, σ_N , was obtained from the power transmitted through the sample in the normal state, P_N , according to the expression⁵

$$\sigma_N = (-RP_N + [(RP_N)^2 - 4GP_N(HP_N - 8n^2)]^{1/2}) / 2GP_N dZ_c \quad (1)$$

where

$$G = (n^2 + 1) + (n^2 - 1)\cos(2k\ell) \quad (1.a)$$

$$R = 2(3n^2 + 1) + 2(n^2 - 1)\cos(2k\ell) \quad (1.b)$$

$$H = n^4 + 6n^2 + 1 - (n^2 - 1)^2\cos(2k\ell) \quad (1.c)$$

with Z_c the characteristic impedance of the waveguide, d the film thickness, ℓ and n the substrate thickness and the index of refraction respectively, and k the wave number. At temperatures below the beginning of the transition, the microwave conductivity takes the form $\sigma^* = \sigma_1 - j\sigma_2$. We have calculated σ_1 by using $\sigma_1 = \sigma_N(T/T_c)^4$, as defined under the two-fluid model approximation. Values of σ_2 were obtained using the relation⁵

$$\sigma_2/\sigma_c = -\beta/(2\sigma_c dZ_c) + \{[(\beta/2)^2 - \gamma]/(\sigma_c dZ_c)^2 - \alpha\sigma_1/\sigma_c^2 dZ_c - (\sigma_1/\sigma_c)^2 + \dots\}^{1/2} \dots (P_c/P_s)[1 + \alpha/\sigma_c dZ_c + \gamma/(\sigma_c dZ_c)^2]^{1/2} \quad (2)$$

with P_s the power transmitted through the film for $T < T_c$, σ_c and P_c are the conductivity and transmitted power respectively at $T = T_c$, $\alpha = R/G$, $\gamma = H/G$ and $\beta = [-2n(n^2 - 1)\sin(2k\ell)]/G$.

Figure 3 shows the temperature dependence of σ_r ($\sigma_r = \sigma_N$ for $T > T_c$ and $\sigma_r = \sigma_1$ for $T < T_c$) for the samples under study. The conductivities ($\sim 2.3 \times 10^5$ S/m) at room temperature are in close agreement for the two films considered. These values also compare favorably with reported values for the dc conductivity in this type of film.¹¹ Hence, using the value of σ_N we found a typical resistivity, ρ , of about 435 $\mu\Omega\text{-cm}$ at room temperature and of 133 and 160 $\mu\Omega\text{-cm}$ at temperatures around 100 K, for the 0.7 and 0.4 μm films respectively. These resistivity values are on average a factor of 1.5 greater than the values for ρ ($\rho \sim 290$ $\mu\Omega\text{-cm}$ at 300 K and $\rho \sim 95$ $\mu\Omega\text{-cm}$ at 100 K) obtained from surface resistance (R_s) measurements in strongly c-axis oriented $\text{YBa}_2\text{Cu}_3\text{O}_{7-\delta}$ thin films on SrTiO_3 as reported by Klein, et al.¹² The normal conductivity of both films exhibit a metallic behavior with decreasing temperature, reaching values of $\sim 7.7 \times 10^5$ S/m for the thicker film and of $\sim 6.3 \times 10^5$ S/m for the thinner one, at the onset temperature. Below T_c , the values of σ_1 were obtained using the value of the conductivity at the onset temperature in the expression $\sigma_1 = \sigma_N(T/T_c)^4$. Values for σ_1 of $\sim 6.3 \times 10^5$ and 4.6×10^5 S/m were obtained at 85 K for the 0.7 μm and 0.4 μm films respectively. At temperatures around 50 K and below the values for σ_1 for the 0.7 μm film has decreased by one order of magnitude. Because the 0.4 μm film exhibited leakage of microwave power below 80 K, no data are shown below this temperature.

Figure 4 shows the imaginary part of σ^* for both films. For the 0.7 μm film, values for σ_2 of $\sim 4.9 \times 10^6$ and 7.0×10^6 S/m were obtained at temperatures around 80 and 50 K respectively. These values are greater than those obtained for $\text{YBa}_2\text{Cu}_3\text{O}_{7-\delta}$ laser ablated films deposited on MgO and ZrO_2 .⁵ Due to the leakage sources formed in the 0.4 μm film, we were unable to obtain values of σ_2 at temperatures below 80 K. A value of 3.5×10^6 S/m was obtained just below the onset temperature (~ 92 K) and of 5.4×10^6 S/m at 85 K. Note that the increase

of σ_2 with decreasing temperature corresponds to an increase in electron pairs which implies a reduction of the normal carrier density.

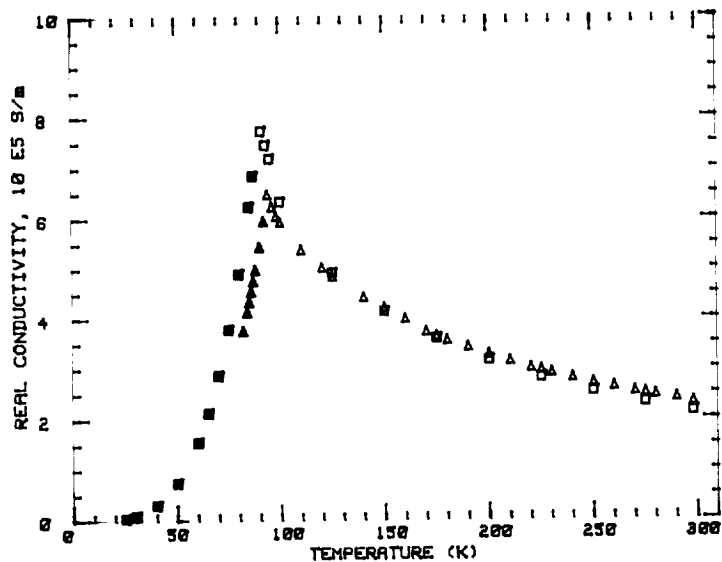

FIGURE 3. Real part of the conductivity, σ_1 , versus temperature for 0.7 μm (□) and 0.4 μm (Δ) laser ablated $\text{YBa}_2\text{Cu}_3\text{O}_{7-\delta}$ thin films on LaAlO_3 at 35 GHz; $\sigma_1 = \sigma_N$ for $T > T_c$ and $\sigma_1 = \sigma_1$ for $T < T_c$. Open symbols represent values of the conductivity calculated directly from power transmission measurements and filled symbols represent values of the conductivity calculated using the two-fluid model.

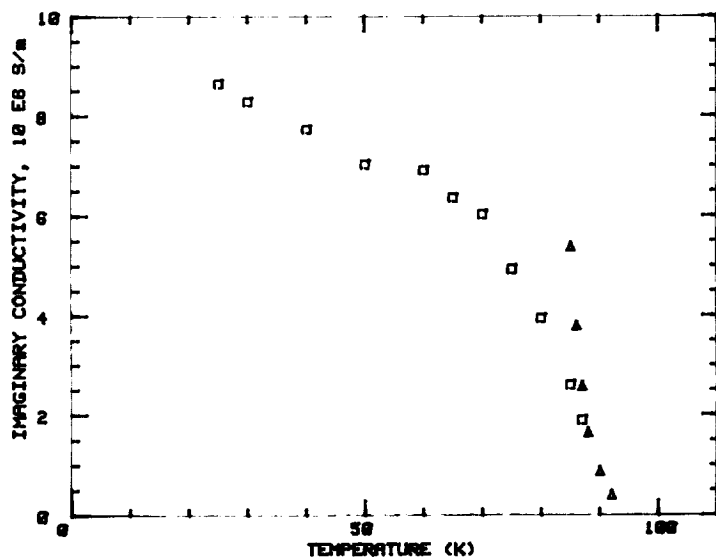

FIGURE 4. Imaginary part of the conductivity, σ_2 , versus temperature for 0.7 μm (□) and 0.4 μm (Δ) laser ablated $\text{YBa}_2\text{Cu}_3\text{O}_{7-\delta}$ thin films on LaAlO_3 at 35 GHz.

The values of σ_1 and σ_2 have been used to estimate values for the magnetic penetration depth λ and the surface resistance R_s .¹³ Values of $\lambda_0=0.67 \mu\text{m}$ and $R_s \sim 9\text{m}\Omega$ at 77 K were obtained. These values are in close agreement with those obtained by other researchers.¹²

The conductivity values have been used to calculate the Q-factor of a ring resonator, which has a superconducting strip and a normal conducting ground plane. This resonator is shown in figure 5 and consists of a microstrip ring with a circumference that is three wavelengths in length at the design frequency of 35 GHz. Straight lengths of superconducting strip provide input to the ring with coupling achieved by small capacitive gaps. The substrate is 10 milliinch thick lanthanum aluminate; and the characteristic impedance of the line is 45 ohms.

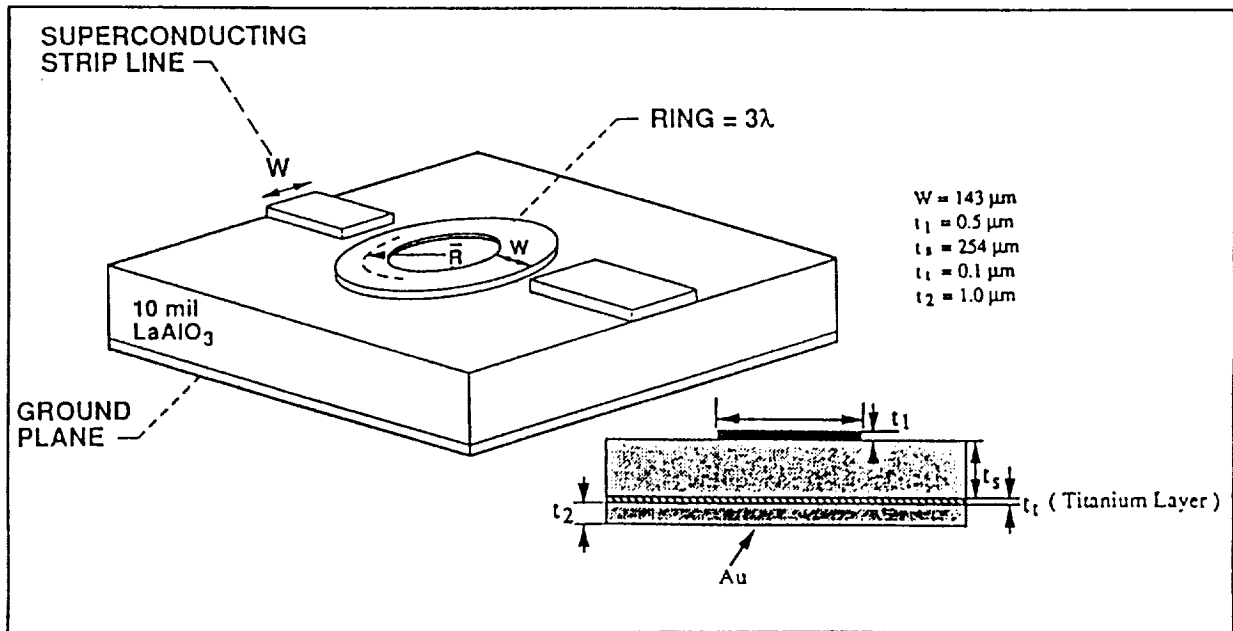

FIGURE 5. 35 GHz ring resonator microstrip transmission line circuit.

The "Q" of the ring is determined by two major loss mechanisms, 1) dielectric loss in the substrate and 2) resistive losses in the conductors. Radiation loss is assumed to be negligible in this case since the resonator, when being measured experimentally, is shielded by a section of waveguide below cutoff which acts to suppress radiation by the circuit. Dielectric losses can be calculated using:

$$\alpha_d = 3.15 (q^* \epsilon / \epsilon_{eff}) (\tan \delta / \lambda_g) \text{ Nepers/m} \quad (3)$$

where α_d ¹⁴ is the attenuation constant due to dielectric loss, 'q' is a geometrical 'filling factor', ϵ and ϵ_{eff} are the static and effective dielectric constants, $\tan \delta$ is the dielectric loss tangent and λ_g is the transmission line wavelength. In these calculations we have used a value of 5.8×10^{-4} for $\tan \delta$ but it should be noted that authoritative values for the loss tangent have not been established.

The conductor losses were calculated by the Phenomenological Loss Equivalence Method (PEM), an analytical solution for loss in microstrip lines that accounts for thin conductors. The attenuation due to the loss in the conductors is given by :

$$\alpha_c = Z_{ri} / (2 * Z_c) \quad \text{Nepers/m} \quad (4)$$

where Z_{ri} is the real part of the internal impedance of the strip and ground plane and Z_c is the characteristic impedance of the line. The internal impedance (Z_i) is obtained through the PEM where:

$$Z_{ix} = Z_{sx} * G_x * \coth(Z_{sx} * \sigma_x * G_x * A) \quad (5)$$

G_x is a geometrical factor, A the cross sectional area of the strip, Z_{sx} is the surface impedance and σ_x the conductivity of the conductor material of the strip or ground plane (x denotes different values for strip and ground plane). The σ values are obtained from the transmission data and the surface impedance is calculated from them. The "Q" of the ring is calculated as:

$$\frac{1}{Q} = \frac{2(\alpha_c + \alpha_d)}{\beta} \quad (6)$$

where β is the propagation constant of the line.

Using values of the conductivity obtained from the $.7\mu$ film and the $\tan \delta$ as noted above, the "Q" values were calculated and compared to results obtained from a resonator made from a film fabricated under similar conditions (figure 7). Also shown are the measured "Q" values for a resonator with a normal metal (gold) strip and ground plane. While the superconducting strip performs better than the normal metal, the measured "Q" values do not follow those predicted by the calculations using the transmission conductivity values.

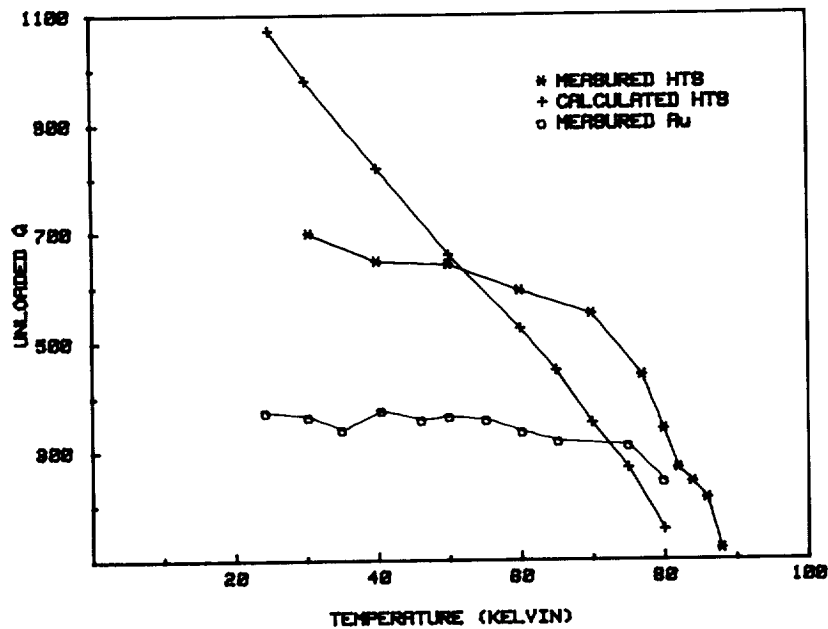

FIGURE 6. Measured and calculated values of unloaded Q for superconducting and normal resonators.

In summary, we have obtained the microwave conductivity at 35 GHz of laser ablated $\text{YBa}_2\text{Cu}_3\text{O}_{7-\delta}$ thin films in the temperature range from 20 to 300 K. The conductivity values at room temperature are in close agreement with dc values reported for the same type of material. Comparing the values for σ_1 and σ_2 for both films with those previously reported for laser ablated $\text{YBa}_2\text{Cu}_3\text{O}_{7-\delta}$ thin films on MgO and ZrO_2 suggest that LaAlO_3 is a superior substrate for microwave applications. From these conductivity values, values for the zero-temperature magnetic penetration depth λ_0 and the surface resistance R_s , fundamental in the design of microwave devices and circuits, have been obtained. We have used the conductivity values to obtain conductor losses and Q-factors of a microwave transmission line. However, predicted and experimentally observed values are not in good agreement. Further work is needed in developing an accurate correlation between measured conductivity values and microstrip performance.

REFERENCES

1. J. P. Carini, A. M. Awasthi, W. Beyermann, G. Gruner, T. Hylton, K. Char, M. R. Beasley and A. Kapitulnik, "Millimeter-wave surface resistance measurements in highly oriented $\text{YBa}_2\text{Cu}_3\text{O}_{7-\delta}$ thin films", *Phys. Rev. B.* 37 (16), 9726-9729 (1988).
2. N. Klein, G. Muller, H. Piel, B. Roas, L. Shultz, U. Klein and M. Peiniger, "Millimeter wave surface resistance of epitaxially grown $\text{YBa}_2\text{Cu}_3\text{O}_{7-x}$ thin films", *Appl. Phys. Lett.* 54 (8), 757-759 (1989).
3. H. Kupfer, C. Keller, K. Salama and V. Selvamanickam, "Inductive current measurements in an oriented grained $\text{YBa}_2\text{Cu}_3\text{O}_x$ superconductor", *Appl. Phys. Lett.* 55 (18), 1903-1905 (1989).
4. P. H. Kobrin, W. Ho, W. F. Hall, P. J. Hood and A. B. Harker, Presented at the M^2S -HTSC Conference, Stanford Ca., July 24-28, 1989. To be published in *Physica C*.
5. F. A. Miranda, W. L. Gordon, K. B. Bhasin, V. O. Heinen, J. D. Warner and G. J. Valco, NASA TM-102345 (1989).
6. F. Huret, D. Kinowski, P. Pribetich and P. Kennis, "Spectral domain analysis of a microstrip thin superconducting line laid on GaAs substrate", *Microwave and Optical Tech. Lett.* 2 (6), 205-208 (1989).
7. K. B. Bhasin, C. M. Chorey, J. D. Warner, R. R. Romanofsky, V. O. Heinen, K. S. Kong, H. Y. Lee and T. Itoh, NASA TM-102526 (1990).
8. A. Inam, M. S. Hedge, X. D. Wu, T. Venkatesan, P. England, P. F. Miceli, E. W. Chase, C. C. Chang, J. M. Tarascon and J. B. Watchman, "As-deposited high T_c and J_c superconducting thin films made at low temperatures", *Appl. Phys. Lett.* 53 (10), 908-910 (1988).
9. B. Roas, L. Schultz, and G. Endres, "Epitaxial growth of $\text{YBa}_2\text{Cu}_3\text{O}_{7-x}$ thin films by a laser evaporation process", *Appl. Phys. Lett.* 53 (16), 1557-1559 (1988).
10. J. D. Warner, J. E. Meola and K. A. Jenkins, NASA TM-102350 (1989).

11. R. T. Collins, Z. Schlesinger, R. H. Koch, R. B. Laibowitz, T. S. Poaskett, P. Freitas, W. J. Gallacher, R. L. Sandstrom and T. R. Dinger, "Comparative study of superconducting energy gaps in oriented films and polycrystalline bulk samples of Y-Ba-Cu-O", Phys. Rev. Lett. 59 (6), 704-707 (1987).
12. N. Klein, G. Muller, S. Orbach, H. Piel, H. Chaloupka, B. Roas, L. Schultz, U. Klein and M. Peiniger, "Millimeter wave surface resistance and London penetration depth of epitaxially grown $\text{YBa}_2\text{Cu}_3\text{O}_{7-x}$ thin films", Physica C 162-164, 1549-1550 (1989).
13. F. A. Miranda, W. L. Gordon, K. B. Bhasin, J. D. Warner and V. O. Heinen, "Microwave Conductivity of Laser Ablated $\text{YBa}_2\text{Cu}_3\text{O}_{7-\delta}$ Superconducting Thin Film on LaAlO_3 Substrate", submitted to Appl. Phys. Lett.
14. R. A. Pucal, D. J. Masse, C. P. Hartwig, "Losses in Microstrip", IEEE Trans. Microwave Theory and Tech., vol. MTT-16, no. 6, 342-350 (1968).
15. R.W. Simon, C. E. Platt, A. E. Lee, G. S. Lee, K. P. Daly, M. S. Wire, J. A. Luine and M. Urbanik, "Low-loss substrate for epitaxial growth of high-temperature superconductor thin films", Appl. Phys. Lett., vol. 53 (26) 2667-2679 (1988).
16. H. Y. Lee and T. Itoh, "Phenomenological Loss Equivalence Method for Planar Quasi-TEM Transmission Line with a Thin Normal Conductor or Superconductor," IEEE Trans. Microwave Theory and Tech., Vol. MTT-37, no. 12, 1904-1909 (1989).

