

N 9 2 - 2 2 4 5 5

## FIBER OPTIC TV DIRECT

**John E. Kassak**  
**Electronic Engineer**  
**Mail Code DL-ESS-12**  
**John F. Kennedy Space Center, Florida**

### ABSTRACT

The John F. Kennedy Space Center (KSC) is sponsoring this project to advance the operational television (OTV) technology for the mid 1990's. The objective is to develop a multiple camera system (up to 256 cameras) for KSC installations where camera video, synchronization, control, and status data are transmitted bi-directionally via a single fiber cable at distances in excess of five miles. It will be demonstrated that the benefits [such as improved video performance, immunity from electromagnetic interference (EMI) and radio frequency interference (RFI), elimination of repeater stations, and more system configuration flexibility] can be realized if application of the proven fiber optic transmission concept is used. The control system will marry the lens, pan and tilt, and camera control functions into a modular-based Local Area Network (LAN) control network. Such a system does not exist commercially at present since the Television Broadcast Industry's current practice is to divorce the positional controls from the camera control system. The application software developed for this system will have direct applicability to similar systems in industry using LAN-based control systems.

### INTRODUCTION

The fiber optic technology of today can provide tomorrow's systems with improved performance in terms of bandwidth, interference immunity, signal-to-noise ratio, flexibility, and reduction in size, weight, power consumption, and cost. NASA KSC is working on the development of a television camera system that will be the prototype for the next generation of television camera, transmission, and control subsystems for the operational television system to be used at the launch pad. The OTV system at the Kennedy Space Center provides real-time and recorded visual information necessary to conduct and document hazardous and nonhazardous activities during daytime and nighttime operations involving buildup, integration, launch, and landing of the Space Transportation System. This engineering and safety information must be of the highest achievable quality. This quality must be sustained without material degradation during duplication, development of training aids and materials, engineering evaluation, and analysis for the detection, investigation, and correction of anomalies. To that end, each element of the system must meet the maximum performance criteria to ensure optimum overall picture quality and resolution. The goals of the television facility at KSC are to provide to the various users (including the launch team, other NASA centers, and the media) a National Television System Committee (NTSC)[4] and RS-170[2] television signal of the highest quality possible and to act as source material for image analysis, media programming, and launch commitment criteria decision making.

### BACKGROUND

The existing OTV system (refer to figure 1) consists of a mixture of color, monochrome, and infrared television cameras. Television cameras with a scan rate approved by the NTSC are presently used to monitor launch operations. Five of the cameras at each pad are broadcast color Charge-Coupled Device (CCD) cameras. The color cameras are strategically located to observe sensitive locations during fueling and launch operations that may be subject to fire. Four combination infrared and visual camera systems are also located around each pad to detect hydrogen fires. The remainder of the cameras are high-resolution, low-light-level monochrome cameras. All cameras are enclosed in hazardproof pressurized housings that provide a controlled environment for the camera and lens. The existing television camera and transmission systems have been developed through an evolutionary process with remnants of the 1960's technology meshing efficiently with today's systems and components. At the launch pad, these cameras are connected to camera control units in the Pad Terminal Connection Room (PTCR) via TV-39 multicore cable. The camera control units contain built-in video equalizers to compensate for loss in transmission on the cable. The video output from the camera control unit is connected

to a frequency modulation - radio frequency (FM-RF) modulator. The radio frequency outputs of these modulators are combined onto coaxial trunk cables. The trunk cables proceed through numerous repeater stations to the Launch Control Center. In the Launch Control Center, the radio frequency signal from these trunks passes through a splitter to individual demodulators. This transmission system was designed to meet the requirements of Network Transmission Committee (NTC) Report No. 7[6]. The demodulated video signal is then fed to a video routing switcher for distribution to the end user, to recorders for documentation of launch operations, and to the NASA Select channel for use at other NASA centers. There are 16 pressurized buried RG-247 cables fed from Pad 39A and 16 fed from Pad 39B. Two sync signals are modulated and also transmitted on separate channels from each pad to the Launch Control Center[1].

The FM-RF transmission system RF bandwidth is 6 megahertz (MHz). The modulation bandwidth (BW) is 4.5 megahertz permitting pictures with 356 lines of horizontal resolution to be recorded and viewed by the operational television facilities. The theoretical value for horizontal resolution (Rh) is given by the equation [5]:

$$Rh = \frac{2Ta * \Delta f}{A} = \frac{2(52.6 \mu\text{sec.})(4.5 \text{MHz})}{1.33} = 355.93 \text{ lines}$$

**WHERE:**

Rh equals the horizontal resolution, in terms of the maximum number of discrete lines observable, when utilizing a test chart, on a horizontal scan line segment whose length is equal to the picture height.

Ta equals the active line scan time in microseconds; for RS-170, TA=52.6 μsec.

Δf equals the available bandwidth of the transmission channel in megahertz; for the FM-RF system, Δf=4.5 MHz.

The A equals the television systems aspect ratio; for NTSC, the picture width is 4/3 of the picture height, so for the NTSC, A=1.33.

(The factor 2 is introduced because each cycle (Hertz) produces an observable picture consisting of a black line and a white line.)

The cameras are controlled at the Launch Control Center operational television control room by a microprocessor-based digital control system, capable of controlling 255 cameras. There are six operating stations in the control room: one master operator and five camera operating positions. There are also maintenance keypads at Pad 39A, Pad 39B, and the Orbiter Processing Facility (OPF). The news facility has a control keypad to control the public affairs color cameras at the pad. Each operating position can control pan and tilt, zoom, and focus on any camera connected to the system. Additional functions available include power on/off, auto or manual iris, and high or normal sensitivity for color cameras. Some cameras carry onboard lights that can be turned on and off by the control system. The existing system was developed by Vicon Industries for monochrome surveillance camera systems. Although the existing camera control system is microprocessor based, the operator control panel and camera interfaces are primarily hardware based. This situation results in system limitations on the type, number, and compatibility of control functions that can be interfaced. A complete hardware design and development is necessary for control of the new system.

**PROPOSED SYSTEM CONCEPT**

First, the video bandwidth for the transmission from the launch pads to the Launch Control Center must be increased for the higher resolution video available from state-of-the-art cameras. Second, a complete hardware design and development is necessary for the camera control system.

The goal of this development effort is to develop specifications for a multiple color camera system where each camera is interfaced to a single fiber at the pad, to replace the existing system. The opposite end of the fiber is connected to the video camera control system in the Launch Control Center. Refer to figures 2 and 3. The single fiber will utilize bi-directional transmission of video, synchronization, control, and status signals. The concept will eliminate the necessity for camera control and synchronization equipment at the pad and eliminate

the requirement for repeaters between the pad and the Launch Control Center. The camera control unit and camera head each contain a fiber optic transmitter and receiver connected to the optic fiber via a wavelength division multiplexer. Signals for synchronization and control of the camera and of the pan and tilt are transmitted from the camera control unit to the camera head on one optical wavelength [1550 nanometers (nm)] while the camera video output and status information are returned on the same fiber utilizing a different wavelength (1300 nanometers). The new camera control system (refer to figure 3) utilizes a host central processor and LAN to provide control, monitoring, and automatic fault reporting for the OTV system.

It is planned to use single mode fiber scheduled to be installed as part of the cable plant in Launch Complex 39 area. At KSC all fiber optic video links are designed to meet the specifications of EIA-RS-250C short haul [3]. The optical fiber cables at KSC contain from 36 to 144 fibers and are installed in existing underground ducts or manholes or are directly buried.

The optical specifications for the KSC single mode fiber are:

1. Equivalent to step index glass
2. Core diameter 8.7 micrometer typical
3. Optical attenuation  $\leq 0.5$  dB/km (1250 to 1350 nm)
4. Cladding diameter  $125 \pm 2$  micrometer
5. Chromatic dispersion  $\leq 0.95$  ps/(nm<sup>2</sup>-km) dispersion slope at  $1310 \pm 12$  nm wavelength range
6. Mode field diameter of 1300 nm optical spectrum peak within the range of  $8.7 \mu\text{m}$  and  $9.8 \mu\text{m}$

Instead of obsolete TV-39 multicore cabling and parallel analog control architecture, the conceptual system utilizes optical fiber and serial data communications to maximize the ability to address the control camera functions, camera types, and other devices. Thus, any camera or device, with a serial control interface, can be integrated into the system permitting full utilization of all the device's functions by remote control.

Each camera station is connected to a transmission system whose only hardware interface requirements are two serial ports and the appropriate video cabling. This allows different types of transmission systems to operate in the system with minimal integration effort. This transmission system need not be used if the camera is close to the control center.

## HARDWARE IMPLEMENTATION

The first prototype system was developed and demonstrated in the laboratory before field deployment at Pad 39A. An Ikegami model HC-240 camera utilizing three 1/2-inch frame interline transfer charge coupled devices, with resolution in excess of 700 lines, was used for this phase of the project. The standard camera offered most of the features required for our project including an RS-232 serial data port and published control protocols. This simplified integration with a PC-based control system permitted us to concentrate software development on the user interface and logical groupings for camera, lens, and pan and tilt unit functions. Camera manufacturers do not typically integrate the lens zoom and focus functions or the pan and tilt system control functions into the camera control system. This meant that a separate procurement was required for a pan and tilt system that would support these lens functions and offer a serial data interface. Telemetrics provided the variable speed pan and tilt head, its control system, and the lens integration to support zoom, focus, and remote operation of a 2x lens extender for telephoto applications.

The fiber optic transmission equipment was provided by PCO, Inc. The optical transmission was made on single-mode fiber. Wavelength division multiplexers (WDM) were used at each end of the fiber to permit single-fiber bidirectional transmission. Wavelength division multiplexers allow for two optical frequencies to be inserted on the same fiber. The same device can be used to separate the two wavelengths permitting the use of two independent channels on a single fiber. The analog nature of the signals, the limits of the FM deviation used by the PCO transmission equipment, and the NASA requirements for signal-to-noise ratios dictated the need of high isolation WDMs. Optical crosstalk isolation needed to be 35 decibels or better in order to ensure the signal-to-noise ratios that NASA required after conversion back into the electrical domain. The WDMs selected

were manufactured by JDS, Co. and utilize optical filters in their construction. They are quite small and passive and should provide extremely high reliability. The system is designed to operate on both multi-mode and single-mode fibers; however, different WDMs are used for different types of fiber. The system was tested on multi-mode fiber out to 8 kilometers and on single-mode fiber over 17 kilometers with minimal degradation of video quality.

A 1550-nanometer wavelength injection laser diode (ILD) optical transmitter with dual audio channel subcarrier modulators was utilized at the control station end to transmit genlock synchronization video and control data to the camera and pan and tilt systems. At the camera, a PINFET optical receiver and dual audio subcarrier demodulators converted the optical signal back to the electrical domain. A 1330-nanometer ILD transmitter with dual audio subcarrier modulators was utilized at the camera to return the camera and pan and tilt status data along with the camera's video output to the control station.

The control and status serial data were connected via modems to the audio subcarrier modulators/demodulators. The audio subcarrier frequencies were set as near the upper limit of the fiber optic transmitter's video passband as the equipment permitted. This permitted in excess of 8.5 megahertz for the video transmission bandwidth (refer to figure 4). The audio subcarriers were summed with the video channel and this summed signal frequency modulated a carrier which in turn modulated the optical source. At the remote end of the fiber, the PINFET optical receiver detected the optical signal and the resulting FM carrier was demodulated into a video signal and two audio subcarriers. For the video channel, a low pass filter was employed to remove the audio subcarriers from the upper end of the system passband. In an attempt to improve the system video channel group delay performance, the use of notch filters for the audio subcarrier frequencies will be evaluated in the future. The data channels were demodulated by the audio subcarrier demodulators and the outputs connected to modems. The prototype systems performance characteristics can be seen in table 1.

Table 1. System Performance Comparison Table

<u>PARAMETER</u>	<u>PROTOTYPE</u>		<u>RFA</u> <sup>3</sup>	<u>RFB</u> <sup>4</sup>	<u>EAI-250C</u>	<u>NTC-7</u>
	<u>LAB</u> <sup>1</sup>	<u>PAD A</u> <sup>2</sup>			<u>SHT. HAUL</u>	
Frequency Response (MHz)	.5-8.5	.5-8.5	.5-4.5	.5-4.5	N/A	N/A
(dB)	+0-1.1	+0-1	-.02+.25	-0+.25		
Pulse/Bar Ratio	97.1%	95.4%	102.4%	100.6%	N/A	±6 IRE
2T Pulse K-factor (%)	0.5	0.9	1.4	1.3	N/A	N/A
S/N Unweighted (-) (dB)	61.7	59.1	46.3	46.1	N/A	50
S/N Lum-Weighted (-) (dB)	67.8	66.3	56.8	55.3	67	53
Chroma-Lum Delay (ns)	-3.5	-4.1	-5.6	1.2	N/A	±75
Chroma-Lum Gain	100.2%	95.6%	95.6%	99.5%	±2 IRE	±3 IRE
Differential Gain (%)	0.66	0.84	2.16	3.08	2	15
Differential Phase (degree)	0.22	0.91	1.72	2.60	0.5	5
Lum Nonlinearity (%)	0.37	1.3	4.3	4.9	2	10

1. With a continuous spool of 17.6 kilometers fiber
2. With a fiber path of 17 kilometers with 18 connectors
3. RFA-Radio Frequency Transmission Pad B Channel 7, cable path length 7.2 kilometers
4. RFB-Radio Frequency Transmission Pad B Channel 9, cable path length 7.2 kilometers

## SOFTWARE DEVELOPMENT

The initial prototype's control software was developed in C language. The software provides the user access to and status reporting of the camera, lens, and pan and tilt system functions. The user selects the appropriate menu heading of camera, lens, or pan and tilt system and the supported functions are then displayed. When the user selects a function from the menu, a submenu is then displayed to report the system status and the user action required to change the current system status. The initial prototype supports a single camera, lens, and pan and tilt system. The pan and tilt functions supported are the selection of direction (up, down, clockwise, and counterclockwise), the selection of proportional or constant speed, and setting the value for the constant speed and speed range for proportional speed. The lens functions supported are: (1) focus (near or far), (2) zoom (wide angle or telephoto), (3) selection of a 2x extender for telephoto applications, and (4) the selection of the speed that the zoom and focus operations will change. The camera functions supported include: (1) color bars on/off, (2) the selection of inserted title symbology on the camera video (such as a camera number), (3) automatic white and black balance, (4) the selection of the camera shutter speed, (5) the selection of the mode of iris control (manual, automatic, and automatic with manual trim or closed), (6) detail levels, (7) paint controls for individual color channel gain, (8) black level setting, and (9) gain.

A second prototype control system is under development. This system addresses multiple camera systems of differing functions by use of modular software driver packages for each type of system to be controlled. In addition, the software design is object oriented to permit ease of operator reconfiguration as additions, deletions, and changes are made to the system. The second prototype uses a LAN to permit multiple users access to all camera systems on the network as shared resources. Individual permission tables could permit restrictions to be imposed on the functions to be accessed by the user on an individualized basis. The modular-based device drivers permit individual control units to have differing menu functions according to privilege level. These drivers also allow menus to be tailored to address all the specific functions a camera system supports. Many existing camera control systems only offer a hardware-limited subset of the camera system functions. In addition to the control functions, the second prototype system is intended to monitor system status to provide automatic fault reporting. It will also provide remote monitoring and reporting of the pressure and temperature in the pressurized camera, pan and tilt, and light housings.

## MEASURED DATA

A series of tests of the existing and prototype television transmission systems was conducted to evaluate the potential benefits of fiber optic transmission for OTV signals used in monitoring and documenting launch processing operations at KSC. These tests supplied both subjective and objective data on the benefits of improvements in this transmission media to the monitoring of launch operations. The prototype system total channel bandwidth of the video and control signals is 12 megahertz. The video bandwidth transmitted is now 8.5 megahertz. Since the existing RF system only allows 4.5 megahertz, the picture resolution is approximately doubled from 356 lines (refer to the previous calculation in the Background paragraph) to 672 lines, where  $R_h = [T_a \cdot \Delta f] / A = 2[52.6 \mu\text{sec.}] [8.5 \text{MHz}] / 1.33$ , since  $\Delta f$  now equals 8.5MHz. Observations made using standard Electronic Industries Association resolution charts support the calculated results. Other measurements are listed in table 1. A decrease of picture distortion is attributable to a differential phase reduction from 2 to 0.91 degree and a differential gain reduction from 3 to 0.84 percent. Other improvements, for example, include an improvement in signal-to-noise ratio from 56 decibels to 66 decibels has been attained under field deployed conditions.

## FUTURE DEVELOPMENTS

In 1991, while the first prototype camera station and transmission system is being field deployed to Pad A perimeter site 2, a second prototype camera station and transmission system is being developed. This prototype camera station is intended to be field deployed on the fixed service structure at the pad. Its purpose is to allow the further definition of system specifications in the areas of modular control system design, multiple camera control over a local area network, improved operator interface, automatic monitoring and fault reporting, and definition of other requirements unique to the launch environment related to the new system design. The

implications and/or benefits of digital processing cameras and of digital video transmission will also be investigated.

### SUMMARY

The application of wavelength division multiplexers for bidirectional fiber optic transmission combined with a modular software-based control system offers an attractive solution to the problems associated with integrating today's high-resolution television camera systems into a demanding operational environment. The technologies required are sufficiently mature and reliable for development into commercial field applications. The main advantages of the system include: (1) the application of a single optical fiber transmission system produces greatly improved video transmission quality and immunity from electromagnetic interference (EMI), RFI, and common-mode problems; (2) no electrical connections are required between remote locations; and (3) conditioning, equalizing, or repeater equipment is no longer required; and (4) a modular software-based control system produces greater flexibility in terms of system configuration, installation, operations, and maintenance. The developed system therefore presents significant advantages in terms of system technical performance and system operations and maintenance.

### APPLICATION TRANSFER

The technology developed by this project has benefits to offer in many commercial applications. The developed system is modular in both hardware and software design approach, thus allowing flexibility in initial system design and installation while permitting substantial growth in terms of addressing additional cameras, lenses, pan and tilt heads, recorders, etc., and additional device functions. The developed system is not susceptible to electromagnetic interference or radiofrequency interference. It is weatherproof and hazardproof and offers high quality, secure video transmission in harsh environments at distances approaching 20 kilometers. The potential commercial applications of this technology include: (1) an inexpensive, lightweight replacement for triax-based transmission/control systems for television broadcast cameras in both studio and field applications, (2) wide area coverage for indoor and outdoor closed-circuit television and security systems, (3) high-quality remote visual monitoring of industrial or hazardous processing facilities, (4) monitoring of underwater facilities or operations, (5) remote visual monitoring for offshore oil drilling platforms, and (6) bidirectional intrafacility teleconferencing.

### ACKNOWLEDGEMENTS

The author acknowledges the contributions of team members F. H. Galloway and J. E. Brogdon of Boeing Aerospace Operations, Engineering Support Contract and C. D. Smith and D. A. Carter of Lockheed Space Operations Company, Shuttle Processing Contract. The research described was a joint effort between NASA, Boeing, and Lockheed.

### REFERENCES

- [1] Charles T. Brown, "The Kennedy Space Center Television System," SMPTE Journal, pp 528-540, July 1991.
- [2] Electronic Industries Association EIA Standard RS-170 Revision TR 135, November 1957, Electrical Performance Standards-Monochrome Television Studio Facilities.
- [3] Electronic Industries Association EIA Standard, RS-250C "Electrical Performance Standards for Television Systems," August 20, 1986.
- [4] J. W. Herbstreit and J. Pouliquen, International Standards for Color Television, IEEE Spectrum, March 1967.
- [5] Laurence Thorpe, Hideki Miura and Takashi Chikuma, "Large Screen HDTV Monitor Development," SMPTE Journal, pp 620-621, August 1990.
- [6] Network Transmission Committee, NTC Report No. 7, "Video Facility Testing Technical Performance Objectives," The Public Broadcasting Service, January 1976.

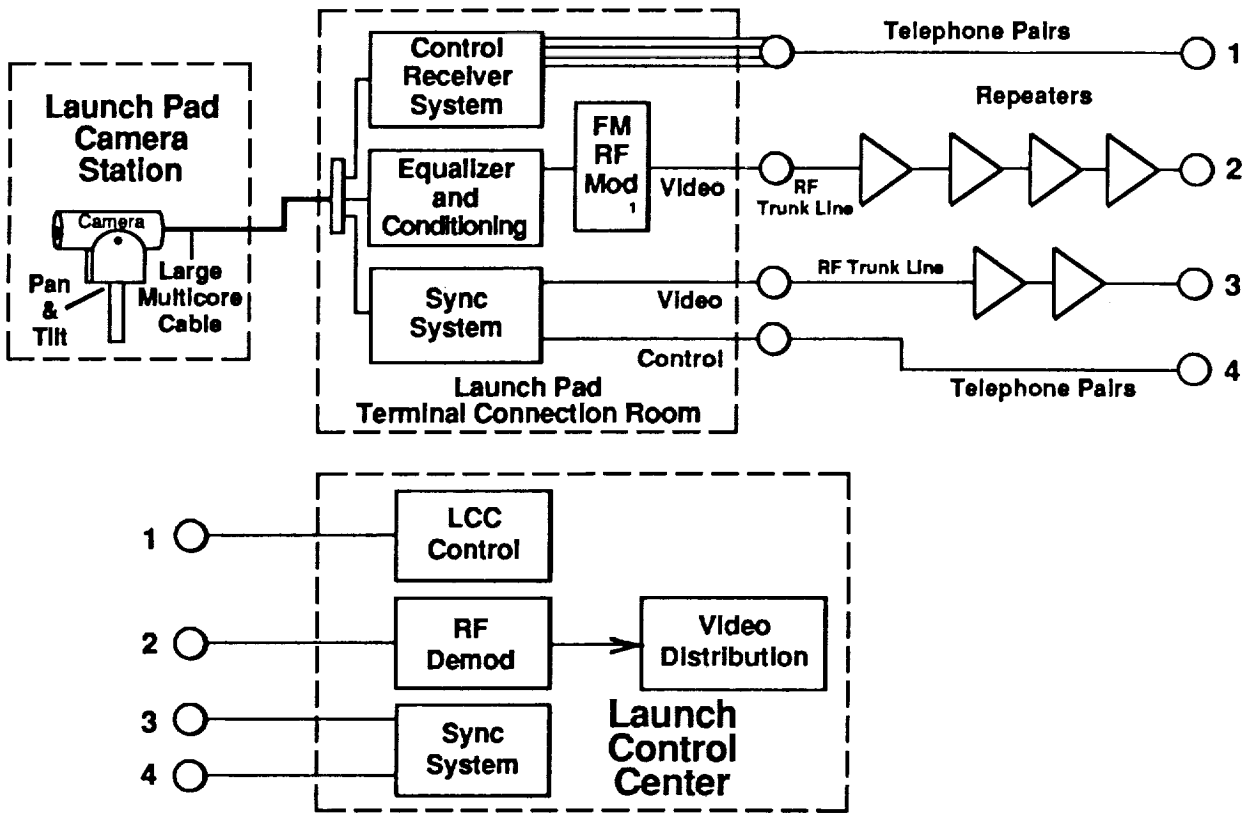

Figure 1. Existing OTV System

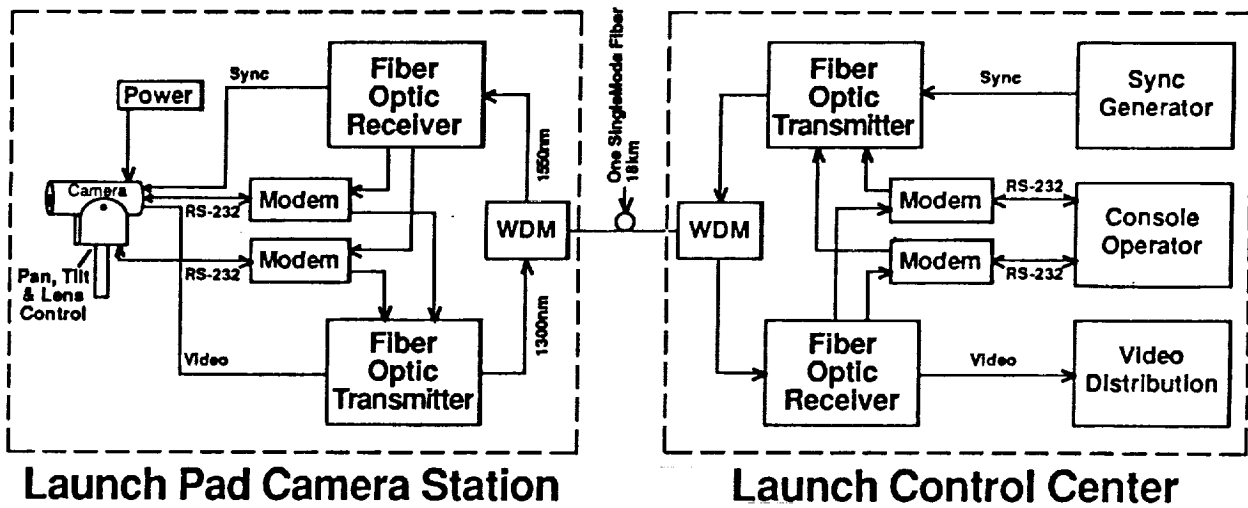

Figure 2. Single Camera OTV System Typical

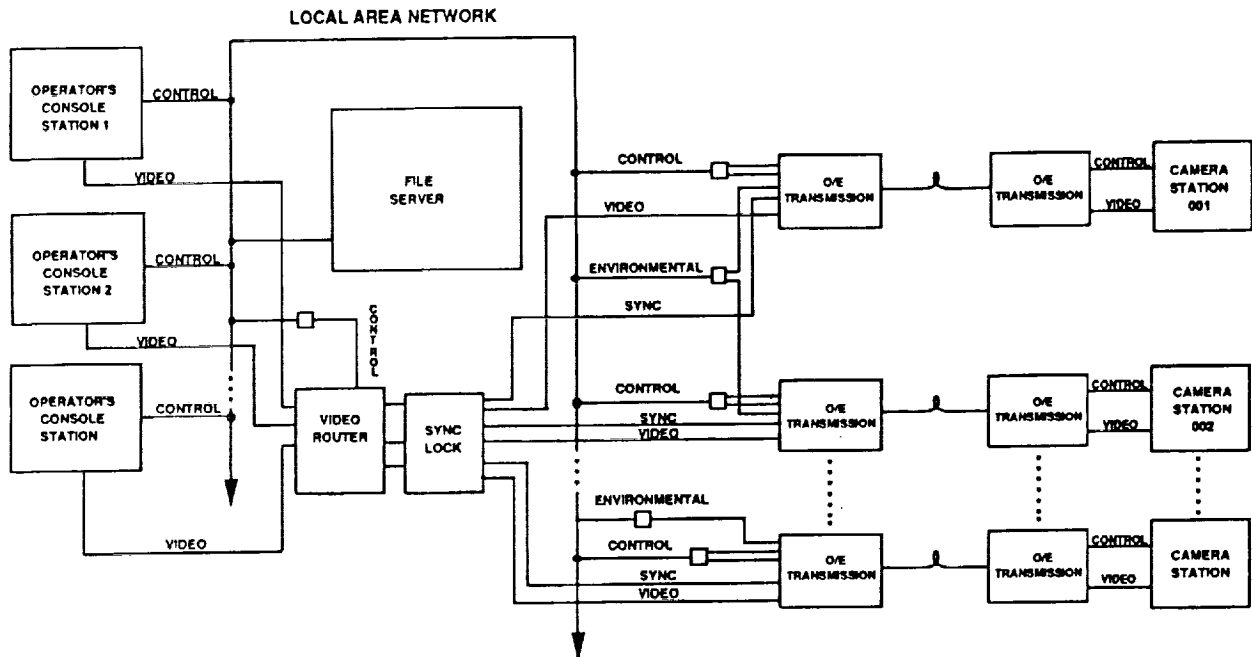

Figure 3. Typical Camera Control System for Multiple Cameras

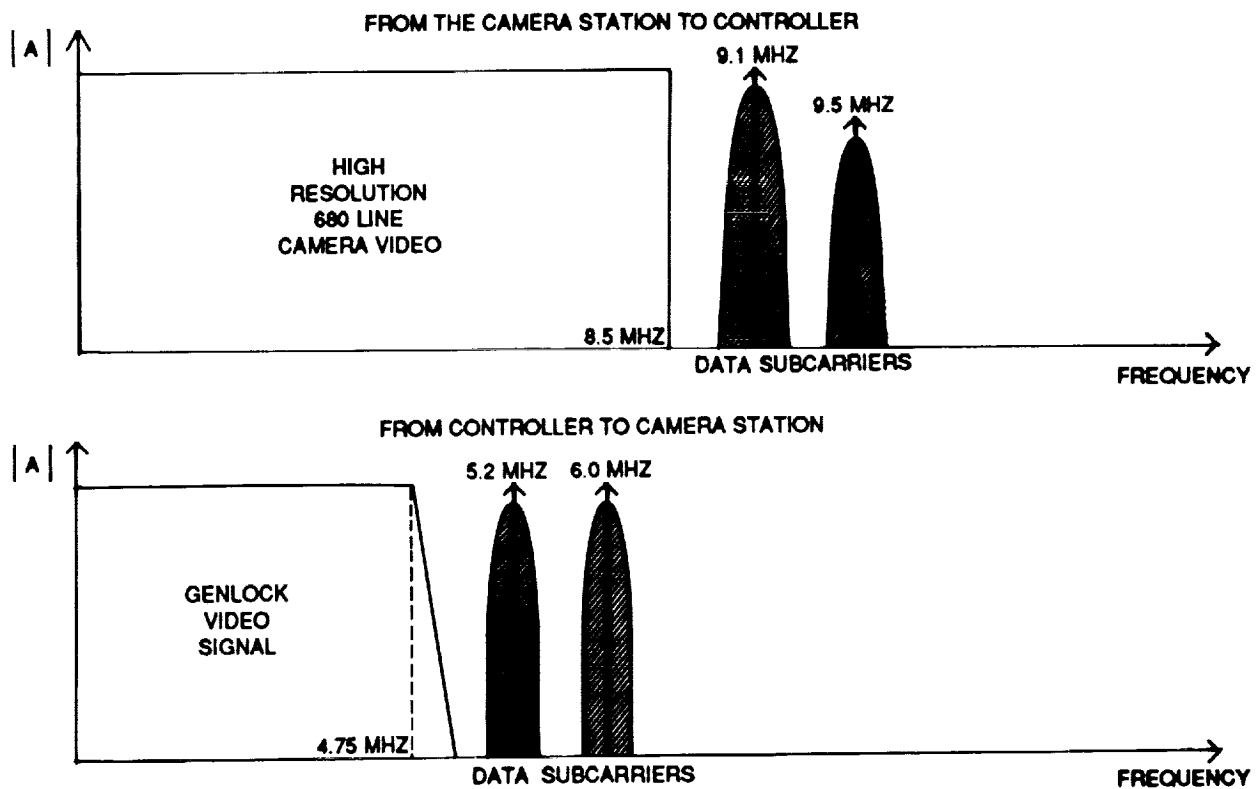

Figure 4. Frequency Modulation Spectrum Designation for Fiber Direct to OTV Composite System



ORIGINAL PAGE  
BLACK AND WHITE PHOTOGRAPH

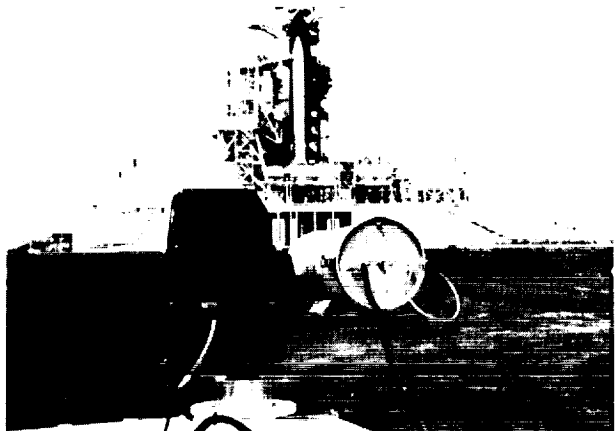

Figure 5. Camera Field Deployment Camera and Pan and Tilt Head

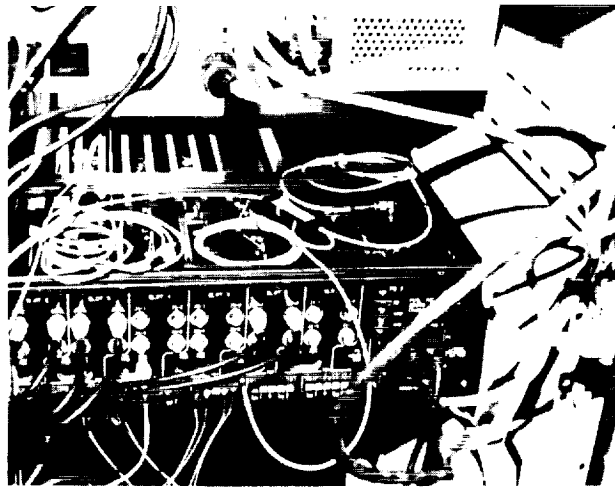

Figure 6. Camera Field Deployment Transmission Equipment



Figure 7. System Control Location Transmission Equipment

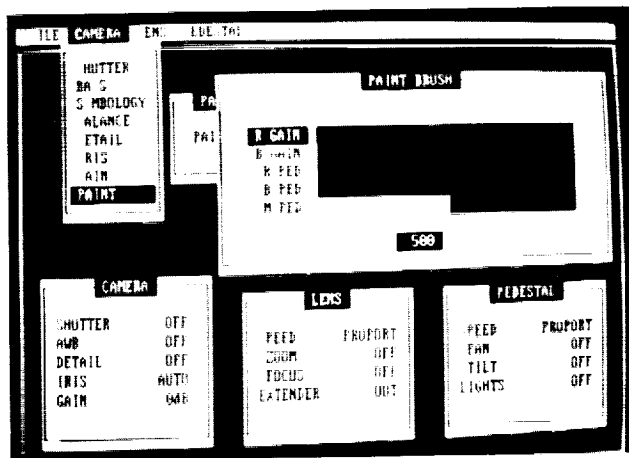

Figure 8. System Operator Interface Camera Menu

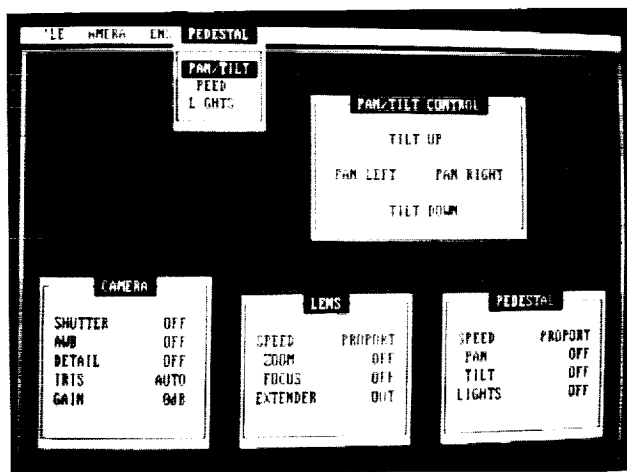

Figure 9. System Operator Interface Pan and Tilt Menu

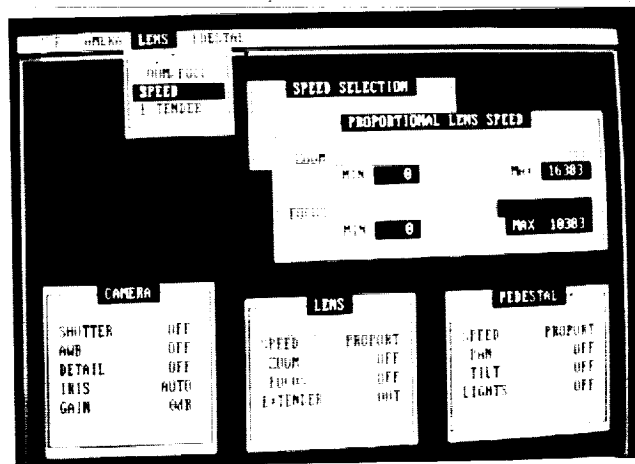

Figure 10. System Operator Interface Lens Menu

ORIGINAL PAGE IS  
OF POOR QUALITY