

Old Dominion University Research Foundation

DEPARTMENT OF CIVIL ENGINEERING
COLLEGE OF ENGINEERING & TECHNOLOGY
OLD DOMINION UNIVERSITY
NORFOLK, VIRGINIA 23529

POLYMER INFILTRATION STUDIES

P-82

By

Joseph M. Marchello, Principal Investigator

Progress Report

For the period December 31, 1991 to March 31, 1992

Prepared for

National Aeronautics and Space Administration
Langley Research Center
Hampton, Virginia 23665

Under

Research Grant NAG-1-1067
Robert M. Baucom, Technical Monitor
MD-Polymeric Materials Branch

(NASA-CR-190204) POLYMER INFILTRATION
STUDIES Progress Report, 31 Dec. 1991 - 31
Mar. 1992 (Old Dominion Univ.) 82 p

N92-22486

CSCL 11C

Unclas
G3/27 0083769

April 1992

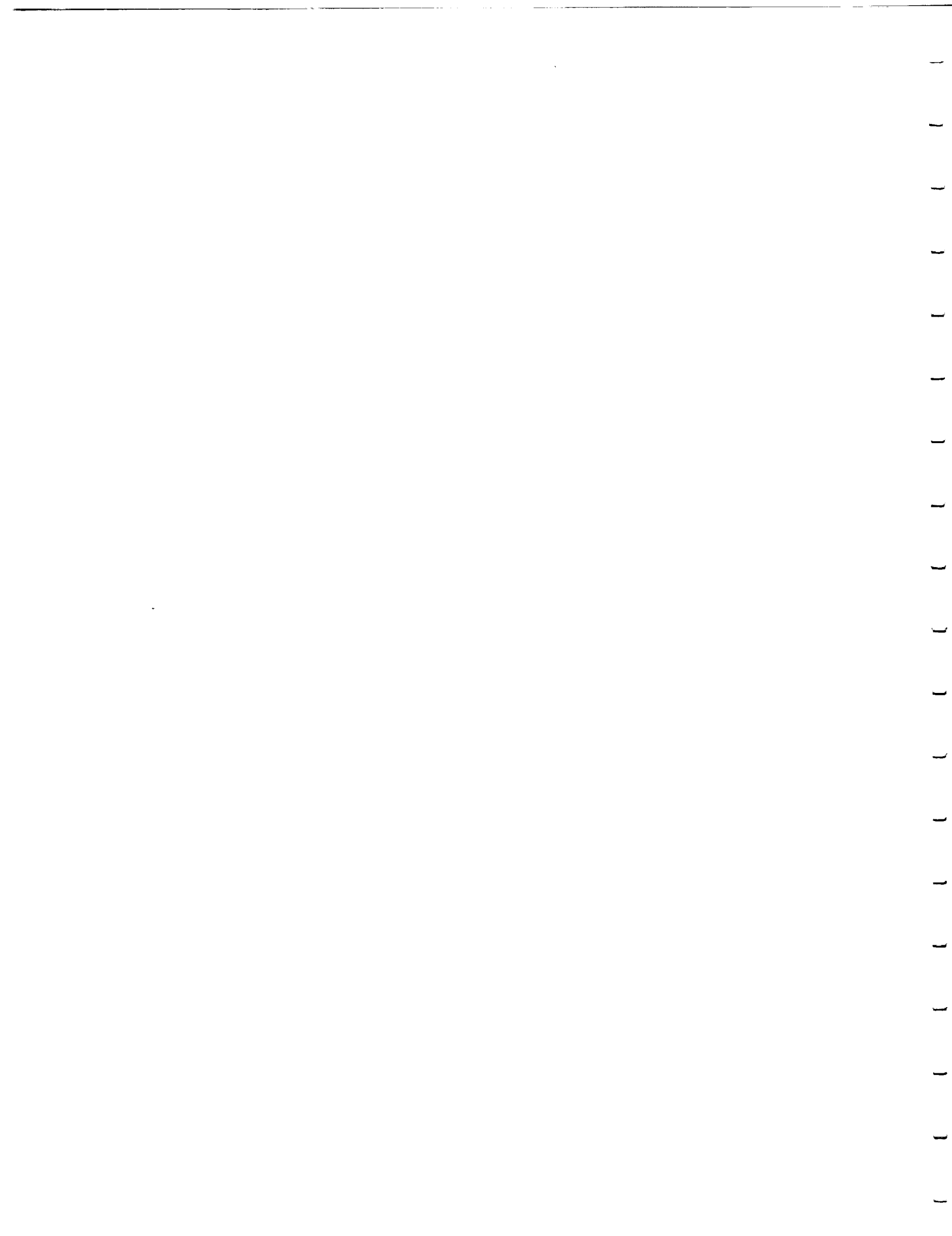

DEPARTMENT OF CIVIL ENGINEERING
COLLEGE OF ENGINEERING & TECHNOLOGY
OLD DOMINION UNIVERSITY
NORFOLK, VIRGINIA 23529

POLYMER INFILTRATION STUDIES

By

Joseph M. Marchello, Principal Investigator

Progress Report

For the period December 31, 1991 to March 31, 1992

Prepared for

National Aeronautics and Space Administration

Langley Research Center

Hampton, Virginia 23665

Under

Research Grant NAG-1-1067

Robert M. Baucom, Technical Monitor

MD-Polymeric Materials Branch

Submitted by the

Old Dominion University Research Foundation

P.O. Box 6369

Norfolk, Virginia 23508-0369



April 1992

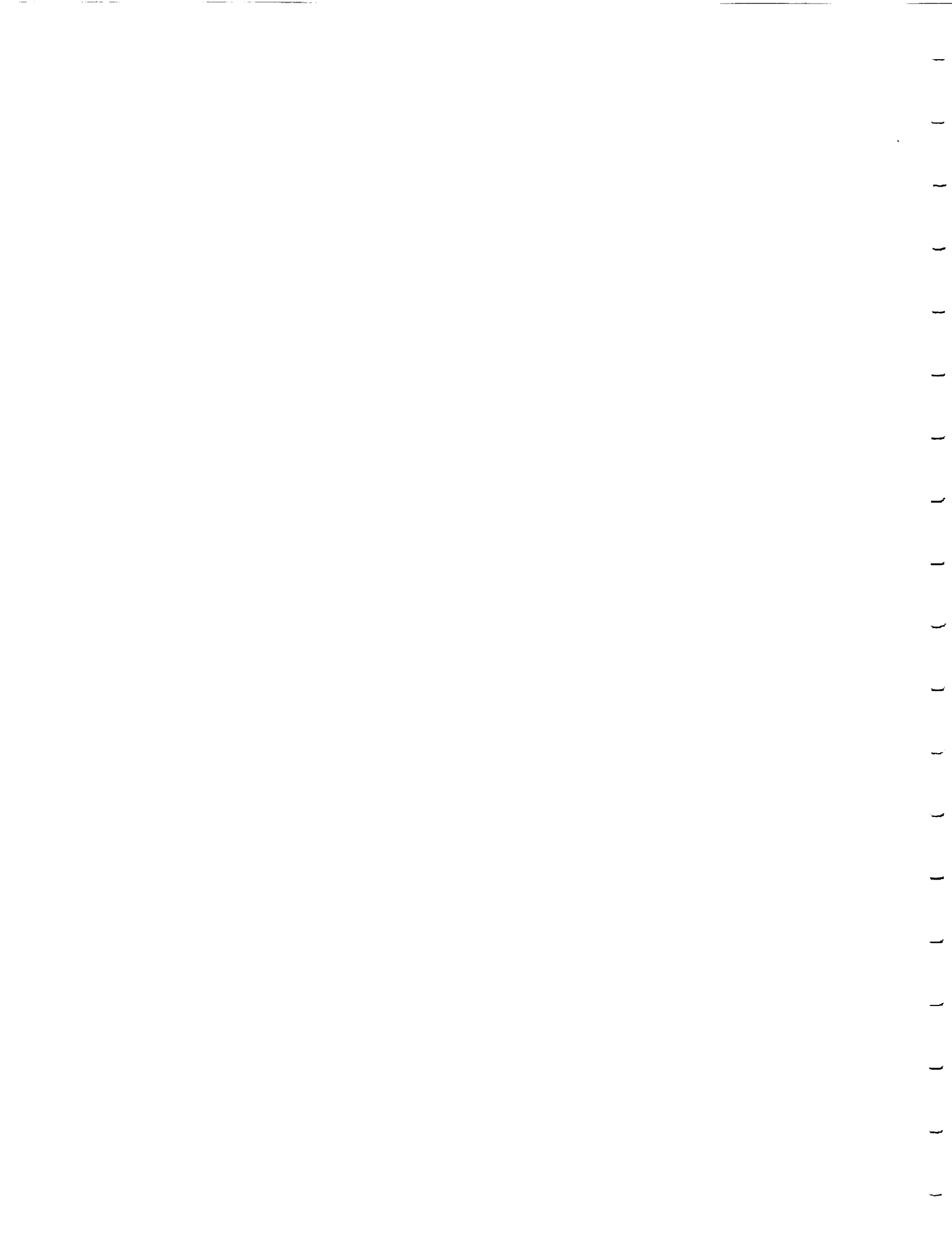

POLYMER INFILTRATION STUDIES

SUMMARY

During the reporting period progress has been made in several areas on the preparation of carbon fiber composites using advanced polymer resins. The results are set forth in recent reports, and publications, and will be presented in forthcoming national and international meetings.

Current and ongoing research activities reported herein include:

- LaRC Powder Process
- Weaving, Braiding and Stitching Dry Powder Prepreg
- Advanced Tow Placement
- Customized ATP Towpreg

Research during the period ahead will be directed toward improved dry powder prepregging preparation of towpreg for textile perform weaving and braiding and for automated tow placement. Studies of multi-tow powder prepregging will be initiated in conjunction with continued development of prepregging technology and the various aspects of composite part fabrication using customized towpreg..

CONTENTS

- I. Introduction
- II. Textile Study - M.K. Hugh
- III. Composite From Powder Coated Towpreg: Studies with Variable Tow Sizes
- IV. Different Approaches to Applying Resin to Fiber

I. Introduction

Polymer infiltration studies during the period have dealt with ways of preparing composite materials from advanced polymer resins and carbon fibers. This effort is comprised of an integrated approach to the process of composite part fabrication.

The goal of these investigations is to produce advanced composite materials for automated part fabrication utilizing textile and robotics technology in the manufacture of subsonic and supersonic aircraft. The object is achieved through research investigations at NASA Langley Research Center and by stimulating technology transfer between contract researchers and the aircraft industry.

The sections of this report cover literature reviews, status report on individual projects, current and planned research, and publications and scheduled technical presentations.

Memorandum

To: J. M. Marchello, N. J. Johnston, R. M. Baucom
From: Maylene Hugh
Date: February 14, 1992
Subject: Textile Study

Objective

To continue the development of powder-coating technology for textile applications in composite part fabrication. This work parallels the effort on thermoset powders that is currently being performed at BASF as part of the ACT program with NASA and Lockheed. The powder prepregging program at NASA uses both thermosetting and thermoplastic powders, and is a dry powder prepregging method, which is distinct from the BASF slurry process.

Introduction

During the period ahead, the dry powder prepregging program for textile applications will have the following approach. Both thermosetting and thermoplastic resins will be investigated for the prepregging of carbon fibers.

This project will entail the powder prepregging to be performed at NASA, and weaving and braiding of fabrics and preforms to be performed by a Contractor. In support of the program, the amounts of towpreg shown in the following table will be prepared by NASA for shipment to the Contractor. Woven and braided materials will be shipped to NASA by the Contractor for tests.

Materials

The program has been divided into four phases of work that will be described later. The constants throughout the study will be one fiber type (12k yarns of AS-4), one epoxy resin (PR-500, CET-3, or RSS1952), one thermoplastic resin (LARC™-TPI), one weave pattern (eight harness satin), and one braid pattern (triaxial braid of [0/+30/-30]). These constants are essential in making useful comparisons of mechanical properties.

Phase	Resin system	Linear feet of 12k towpreg	
		Weaving	Braiding
I	Thermoset	6000	6000
	Thermoplastic	6000	6000
II	TS w/35% r.c.	3000	3000
	TS 40%	3000	3000
	TS 45%	3000	3000
	TS 50%	3000	3000
	TP 35%	3000	3000
	TP 40%	3000	3000
	TP 45%	3000	3000
	TP 50%	3000	3000
III	TS	22,000	22,000
	TP	22,000	22,000
IV	TS	10,000	10,000
	TP	10,000	10,000

A total of 200,000 feet of towpreg amounting to 40 kg will be prepared for weaving and braiding.

During the past year, the appropriate towpreg characteristics have been established along with weaving protocol. The previous issue of towpreg with loose filaments is currently being resolved by redesigning the fiber spreading action and the deposition method. Towpreg that will be produced for this study will be suitable for weaving. NASA will instruct the weaver for rewinding and loom operation necessary to make weaving possible.

While dry powdered towpreg has not been braided, the fiber handling knowledge gained from weaving will be transferrable to the braiding with appropriate allowances for the different machines. The prior NASA experience with textile processing of towpreg will be shared with the Contractor to provide guidance in weaving and braiding operations. Therefore, the Contractor will be primarily expected to provide services using the supplied materials and the machine knowledge.

Approach

Phase I involves the development of cure cycles for both the woven and braided fabrics of thermoset and thermoplastic towpreg. 3" x 3" trial laminates of varying thicknesses will be used to establish the

1
2
3
4
5
6
7
8
9
10
11
12
13
14
15
16
17
18
19
20
21
22
23
24
25
26
27
28
29
30
31
32
33
34
35
36
37
38
39
40
41
42
43
44
45
46
47
48
49
50
51
52
53
54
55
56
57
58
59
60
61
62
63
64
65
66
67
68
69
70
71
72
73
74
75
76
77
78
79
80
81
82
83
84
85
86
87
88
89
90
91
92
93
94
95
96
97
98
99
100

appropriate cure cycle for through-the-thickness resin infiltration. Then, the width and length of the composite will be scaled up to 6" x 6" for determination of area effects on laminate consolidation.

Phase II examines the effects of using dry powder-coated towpreg on weaving and braiding parameters. Towpreg lots of varying resin contents (35-50% resin by weight) will be supplied to the Contractor for iterations on determining the optimum resin content and resulting fiber areal weight. Relationships will be established for percent voids and short beam shear strengths versus fiber volume fraction. 60% fiber volume fraction will be used as the target. With the cure cycle from Phase I, both autoclave and out-of-autoclave processing will be investigated.

Phases I and II will be run somewhat concurrently.

Phase III focuses on the mechanical properties of the woven and braided materials. Tension, short block compression, and compression-after-impact strengths will be measured at room temperature, along with short block compression strengths under hot-wet conditions.

Phase IV results in the fabrication of a stringer panel. This portion will be a culmination of what was determined from Phases I and II, namely the cure cycle and weaving and braiding parameters.



Statement of Work

Subject: Textiles from Dry Powder-Coated Towpreg

The Contractor shall weave and braid materials made from 12k carbon fibers coated with thermosetting and thermoplastic polymer powder. The materials to be used shall be supplied by NASA at no cost to the Contractor. The weaving and braiding shall be executed with guidance from NASA representatives for establishing material handling and loom and braider set-up and operation. Up to 100,000 linear feet of 12k powder-coated towpreg is to be woven into eight-harness satin fabric, and 100,000 linear feet of 12k towpreg is to be braided into triaxially [0/±30] braided flat panel preforms.

During the course of the weaving phase of the work, the Contractor will receive 100,000 linear feet to be provided in six lots of thermosetting polymer towpreg and six lots of thermoplastic towpreg. Five of the six lots will have an average of 4000 linear feet, while the sixth will be approximately 30,000 feet. The smaller 4000 foot lots will have various yarn qualities, specifically different resin contents and different flexural rigidities. Prior NASA experience and the weaving of these five lots, with differing towpreg qualities, will enable NASA and the Contractor to establish optimal weaving operations for the production of high quality fabric from dry powder coated towpreg. This knowledge will be used for the final conversion of the 30,000 feet of towpreg to fabric.

For the braiding phase of the work, the Contractor will be provided with an additional 100,000 feet of towpreg. As with the weaving studies, the 100,000 feet will be supplied in six lots of thermoset towpreg and six lots of thermoplastic towpreg, five of which will be used to establish the optimal protocol for braiding. This information will be used for the final conversion of 30,000 feet of towpreg to braided fabric.

The woven and braided material made by the Contractor from the supplied towpreg shall be shipped to NASA Langley Research Center, Building 1206, c/o Robert M. Baucom, Mail Stop 226, Hampton, VA 23665-5225.

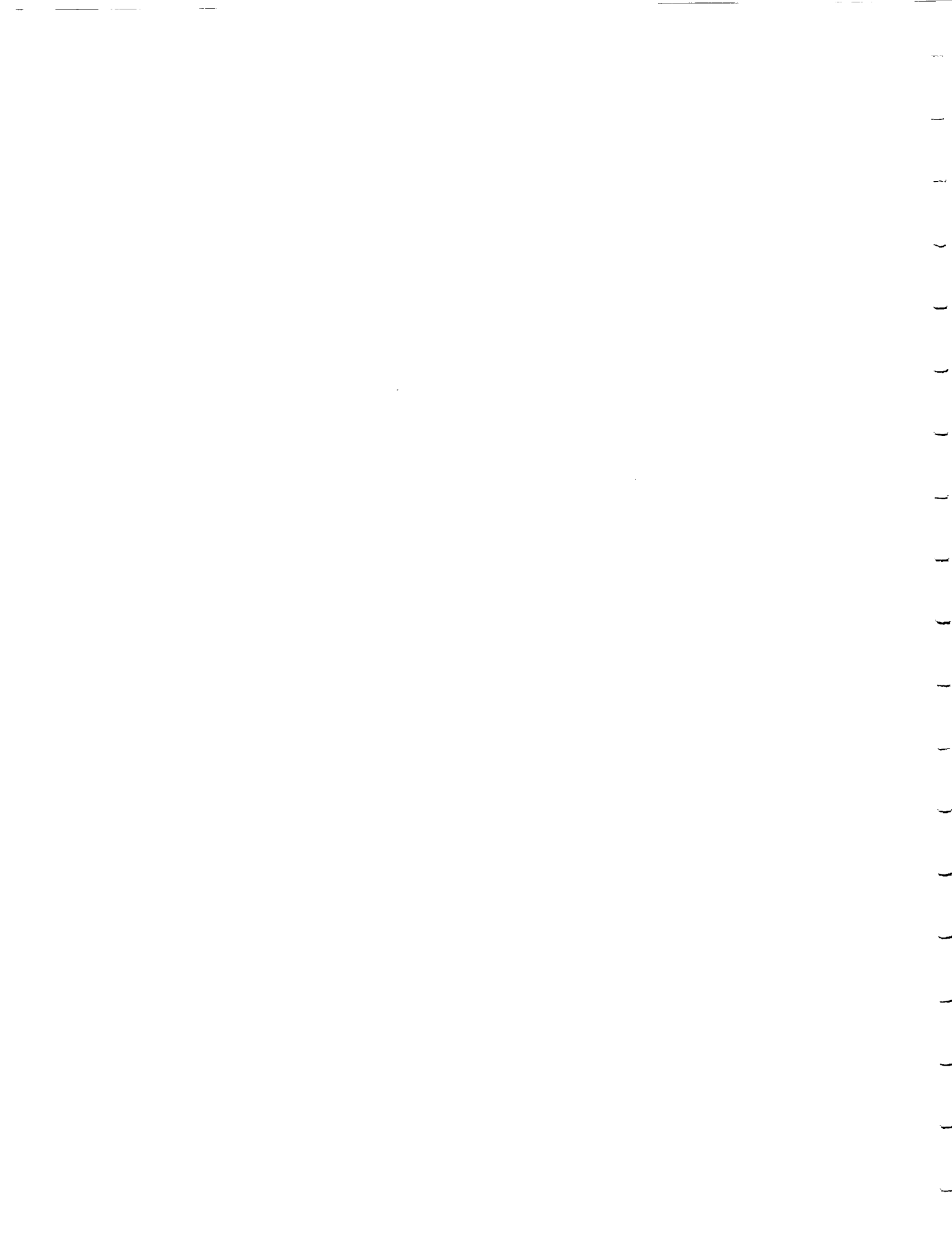

1. INTRODUCTION

Recent developments in powder prepregging have demonstrated that powder coating is applicable to thermoplastics and thermosets and that processing costs are comparable to conventional hot melt prepregging. In conjunction with the development of powder prepregging methods, studies have been conducted on the ways by which the powder towpreg product can be used in the fabrication of composite parts.

Developments in the manufacture of composite parts point toward increased automation utilizing established textile and robotic technology. To be used in these applications, the powder towpreg must be produced in the form of either a weavable yarn or a stiff ribbon. This study dealt with textile applications such as powder coated preforms and broadgoods. One of the objectives of the study was to develop the weaving protocol for powder coated yarns.

Producing powder towpreg and weaving or braiding it into preforms for part fabrication usually costs less when larger tow bundles are used (1). Offsetting the advantage of the use of large tow bundles are factors such as difficulty in processing and reduced composite properties. To address the issue of processing tradeoffs and the possibility of identifying an optimum tow size, various composite specimens were fabricated from powder coated tows and tested. This information, together with the weaving protocol, may serve as a guide in material selection for part fabrication.

In this study, the weavability of dry polymer powder coated fibers and the effects of varying yarn bundle sizes on the mechanical properties of composites made from woven cloth were determined. The fibers used were G30-500 (BASF) and AS-4 (Hercules) carbon fibers in tow bundles of 3k, 6k, and 12k filaments. A weaving protocol was developed for carbon fibers impregnated with a thermoplastic polyimide, LARC™-TPI powder (Mitsui Toatsu). Using the weaving protocol, 3M Company's High Tg epoxy was made into towpreg, woven and tested.

2. DRY POWDER PREPREGGING

The dry powder prepregging process under development at the NASA Langley Research Center (LaRC) was used to produce powder towpreg (2). The powder prepregging process involves three steps: spreading of the tow, deposition of polymer onto the spread tow, and fusion of the polymer onto the fibers. A carbon fiber tow bundle is pneumatically spread to approximately 8 centimeters in width. The fibers are then impregnated by means of a dry,

COMPOSITES FROM POWDER COATED TOWPREG: STUDIES WITH VARIABLE TOW SIZES*

Maylene K. Hugh and Joseph M. Marchello
Old Dominion University
Norfolk, Virginia 23508

Robert M. Baucom and Norman J. Johnston
NASA Langley Research Center
Hampton, Virginia 23665-5225

ABSTRACT

Part fabrication from composite materials usually costs less when larger fiber tow bundles are used. On the other hand, mechanical properties generally are lower for composites made using larger size tows. This situation gives rise to a choice between costs and properties in determining the best fiber tow bundle size to employ in preparing prepreg materials for part fabrication.

To address this issue, unidirectional and eight harness satin fabric composite specimens were fabricated from 3k, 6k, and 12k carbon fiber reinforced LARC™-TPI powder coated towpreg. Short beam shear strengths and longitudinal and transverse flexure properties were obtained for the unidirectional specimens. Tension properties were obtained for the eight harness satin woven towpreg specimens. Knowledge of the variation of properties with tow size may serve as a guide in material selection for part fabrication.

KEYWORDS: Composites; Carbon Fibers; Thermoplastic Resins/Polymers; Thermoset Resins/Polymers; Manufacturing/Fabrication/Processing; Prepregs; Textile Reinforcement.

*This paper is declared a work of the U. S. Government and is not subject to copyright protection in the United States.

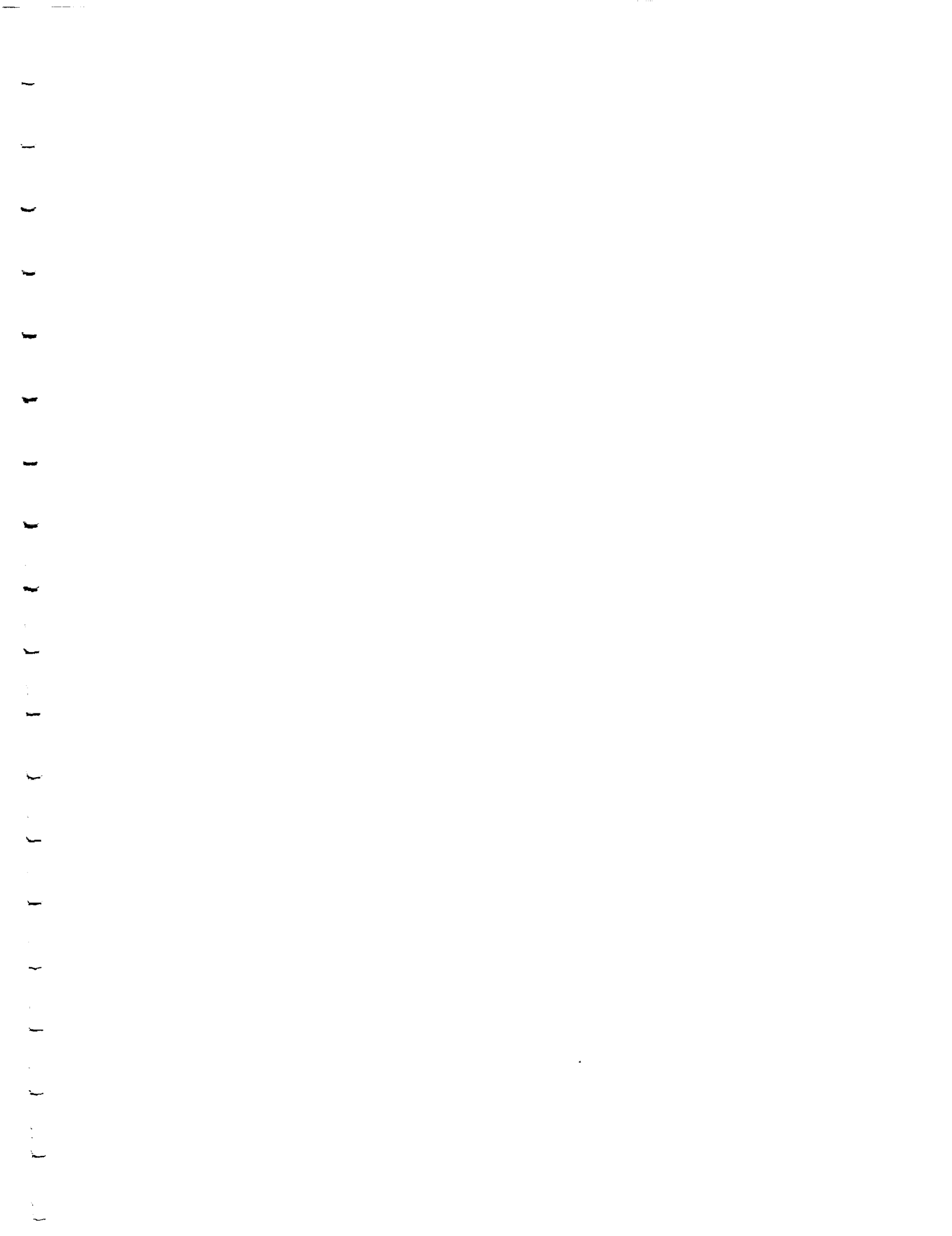

recirculating, fluidized powder chamber. Radiant heating is used to obtain particle-tow fusion. The current system has been upgraded for prepregging operations at speeds of 10 - 15 meters/min. Over 20,000 meters of towpreg were produced for the current study.

3. WEAVING PROTOCOL

The parameters that must be considered to establish a weaving protocol for powder towpreg are listed in table 1. They deal with the properties of the towpreg and its behavior during the weaving process. In addition, the properties of the material that relate to part fabrication must be kept in mind in seeking an optimum processing scheme.

Previous studies for weaving the dry powdered tows dealt with tow flexibility and adhesion of powder particles to carbon fiber (3). Manipulation of the thermal treatment step in the prepregging process enabled successful control over these two variables. Abrasion and fiber damage during weaving were unresolved matters. In this investigation, tow bundle twisting was used to reduce the separation of filaments, tow-to-tow abrasion, and fiber loss.

A weaving protocol was established for dry LARC™.TPI powder and carbon fiber prepreg. The towpreg was woven into eight harness satin cloth under NASA Contract NAS1-18358 by Textile Technologies, Incorporated in Hatboro, PA. The initial work has been performed on yarns containing 6k filaments. Various aspects, such as yarn shape, flexibility, twist, and damage, were investigated to determine the weavability of the current state of the towpreg. The set-up of the loom and the weaving of the towpreg were examined for ways to minimize damage imparted to the woven towpreg.

The first weaving trial involved 6k tow bundles. The towpreg was rewound onto 40 separate spools in order to produce a balanced 10.2 cm (4") wide fabric with 394 picks per meter (10 ppi). Two rewinding machines were used to determine how best to rewind towpreg. The spools of rewound towpreg were loaded into the loom. Initial weaving efforts revealed problems with loose filaments in the tow bundle accumulating in the heddles and comb. Based on a standard of 15 twists per meter for 3k G30-500 (TOHO), the towpreg was twisted prior to weaving. The twisting gave only a marginal improvement in weavability. The combination of reduced tensioning, minimization of turns and bends and care in rewinding provided an appropriate protocol for weaving both twisted and untwisted towpreg.

As shown in figure 1, there was noticeable fiber damage in the woven material. In addition, the photographs show that the action of twisting the tow

15 twists per meter imparts damage to the prepregged yarn. Towpreg fabric analysis is given in table 2. The weave counts, linear weights and woven thicknesses are presented for 3k, 6k, and 12k towpreg.

The ASTM cantilever method for determining fabric flexural rigidity was used to test the towpreg and woven material. The data are presented in table 3.

All of the powdered towpreg have flexural rigidities below the 10,000 mg-cm upper limit for ease of weaving (3). The influence of oven fusion temperature is illustrated by the difference between the two sets of 6k material. A high fusion temperature results in a more rigid towpreg. Woven material generally have a rigidity two to three times higher than the tow. The 12k 3M epoxy tow is less rigid than 12k LARC™.TPI tow primarily because its lower viscosity allows it to flow over the fibers more during the fusion process, whereas the more viscous LARC™.TPI particles tend to bind several fibers together, resulting in tow rigidity.

4. CONSOLIDATION

A study was conducted to establish the parameters for consolidation of woven towpreg material. The major consideration in consolidating woven goods is intra- and inter-tow voids, as well as the inter-ply voids that are of concern in conventional tape processing.

Van West (4) has developed a consolidation model for commingled fiber yarns stitched and woven into drapeable broadgoods and preforms. Iyer (5) studied powder-impregnated thermoplastic composite consolidation as a two step process. Intimate contact at the polymer-polymer interface at numerous sites across the composite, followed by deformation and autohesion, or interdiffusion of polymer chains, to cause the interface to disappear are the two steps.

Based on the models and experiments of Van West and Iyer, a woven towpreg cure cycle was developed, as shown in figure 2. A vacuum press was used to remove air from void spaces in the specimen. Once at temperature, pressure was increased at .05 to .15 MPa/min to 4.2 MPa in order to permit time for resin flow, adhesion, and fiber movement. The pressure ramp was followed by a hold period of one hour for stress release at 350°C for the unidirectional laminates made with 3k and 12k tows and 370°C for the 6k tows and the woven eight harness satin cloth. Cooling below Tg was done to stop consolidation before the thickness curve flattens. This avoids resin squeeze out and resulting dry spots.

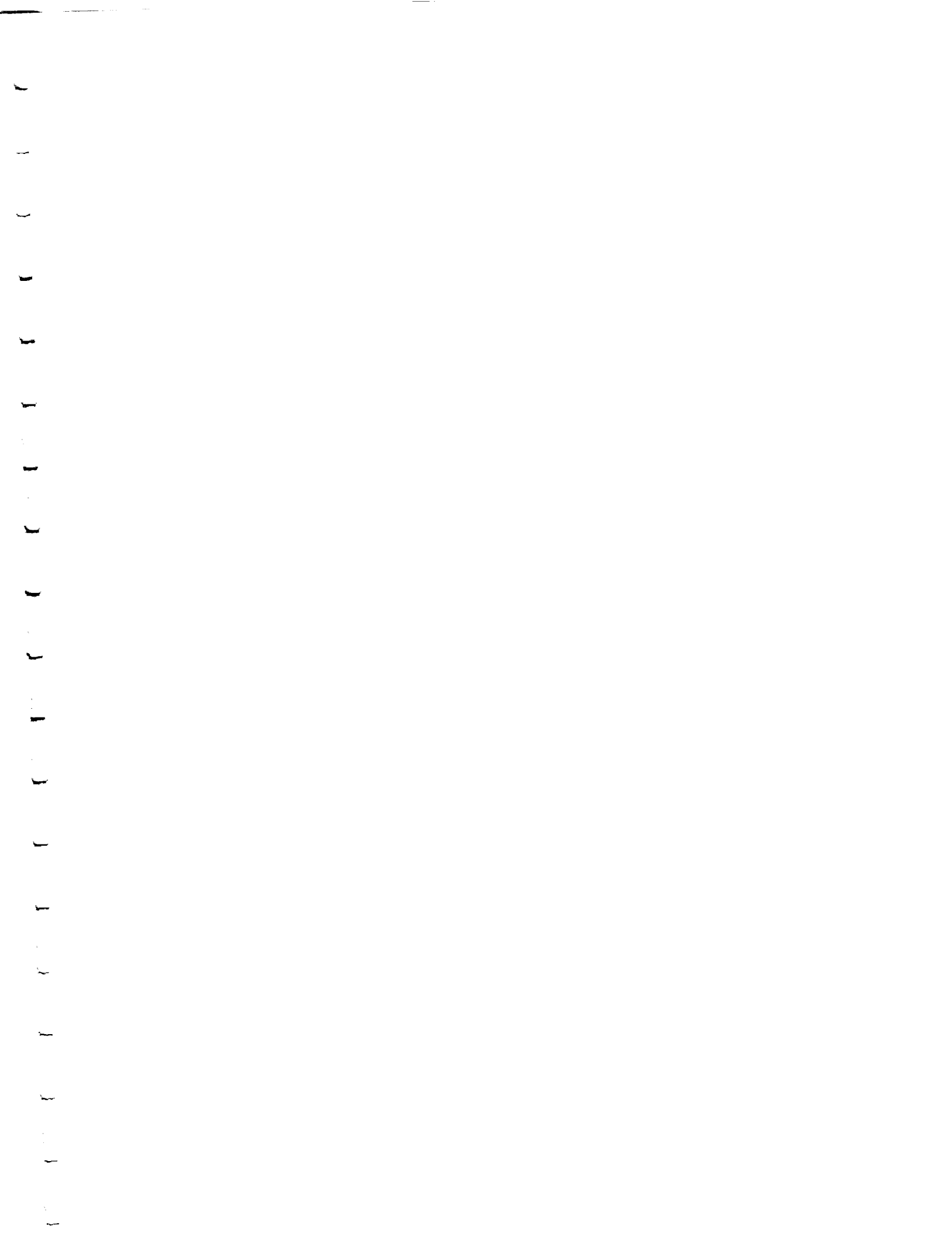

5. MECHANICAL PROPERTIES

A mechanical test program was developed to determine the effects of tow bundle size on the mechanical properties of unidirectional laminates and consolidated panels of eight harness satin cloth. The unidirectional laminates were tested for short beam shear strengths, flexural strengths and moduli, and transverse flexural strengths. Tensile strengths and moduli were obtained in the woven cloths to determine the effects of tow bundle size on the degree of crimp.

Towpreg made from 3k and 6k G30-500, and 12k AS-4 filaments have been frame-wrapped into unidirectional panels to obtain the flexural strength and modulus, the transverse flexural strength, and the short beam shear strength. The data is shown on table 4.

The eight harness satin woven towpreg was consolidated into panels and made into tension test specimens. The specimens have dimensions of 20.3 cm long, 2.54 cm wide, and an average of .374 cm thick (8 in x 1 in x .147 in). The specimens are tested untabbed using hydraulic grips and have a gage length of 10.2 cm (4 in). Only the warp direction is tested due to a lack of material in the fill direction. The mechanical properties generated from this test are compared to the tow bundle size in table 5.

6. DISCUSSION

Learning how to use powder coated tow to make composite materials is an ongoing process. This study has dealt with textile applications, focusing on weaving and consolidation. Some of the operating and design issues in these processes have been resolved while others have been highlighted for further attention.

Weaving powder coated tow in a conventional rapier loom requires that care be taken to minimize fiber damage. There should be as few as possible cyclelets, bends and other tow touch points. Tensioning should be kept low. Rewinding and other handling activities should be minimized.

An important observation regarding weaving and tow size selection is the relation between fiber damage and tow size. During both powder prepregging and towpreg weaving, fiber damage is greater for the smaller tow bundles. This phenomena occurs since damage occurs primarily to the fibers that are at the bundle surface. For a given total amount of fiber, the use of small tows results in larger tow area and correspondingly higher fiber damage.

A consolidation cycle for woven towpreg must account for the inter-bundle crimp of the weave. In general, composites made from woven material will have a lower fiber volume than those made from unidirectional tape. Because of the initial bulk of woven material, vacuum should be applied to avoid the formation of air voids. During consolidation the fibers in woven materials must move and realign. A pressure - time ramp provides for greater ease of fiber movement and perhaps less fiber damage. These steps, together with the general practice of holding at pressure and temperature followed by cooling to stop consolidation, gave void-free specimens of the woven material, as determined by ultrasonic C-scans.

In interpreting the mechanical property data, there is no apparent pattern in mechanical properties of the unidirectional laminates as a result of tow bundle size (table 4). This trend is expected for unidirectional laminates, if the panels are well-consolidated and the fiber and matrix are well distributed within each. The 6k unidirectional towpreg, which shows a high flexural strength, was consolidated at 370°C, whereas the 3k and 12k towpreg were consolidated at 350°C. The increase in temperature for the consolidation cycle not only resulted in an increase in mechanical properties, but also an increase in the processability of LARC™-TPI due to the decrease in viscosity at the higher temperature.

In contrast to the trend displayed in the unidirectional data, the woven cloth will have increased mechanical property values with decreasing tow bundle size, due to the contribution of crimp that will increase with increasing tow bundle size. Indeed, when the woven cloth was tested under tension, the mechanical property values show (table 5) that the maximum tensile stress levels attained in a woven cloth are higher with a 6k tow than with a 12k tow. On examination of the broken specimens, the specimens that were produced using woven cloth of 6k tow bundles broke in the center of the gage length. However, every specimen that was made from woven 12k tow bundles broke near the grips within the gage section, thus possibly yielding a falsely lower stress value. In addition, the lower mechanical property values for the woven 12k tow bundles can also be justified by these panels having a slightly lower fiber volume fraction. This contribution to the differences in the values is not as significant, nonetheless it is a factor.

In light of these issues in comparing the mechanical properties, the matter of optimum tow bundle size remains unresolved. Fiber damage appears to be less when larger tows are used. Weaving and braiding equipment capabilities are somewhat independent of tow size. It appears that the choice of tow

1
2
3
4
5
6
7
8
9
10
11
12
13
14
15
16
17
18
19
20
21
22
23
24
25
26
27
28
29
30
31
32
33
34
35
36
37
38
39
40
41
42
43
44
45
46
47
48
49
50
51
52
53
54
55
56
57
58
59
60
61
62
63
64
65
66
67
68
69
70
71
72
73
74
75
76
77
78
79
80
81
82
83
84
85
86
87
88
89
90
91
92
93
94
95
96
97
98
99
100

bundle size is an open one in regard to properties, but that larger tows are favored, especially in regard to powder processing and weaving costs.

7. ACKNOWLEDGEMENTS

The authors gratefully acknowledge the assistance of Mr. Ricky Smith for coordinating the laboratory activities, Mr. John Snoha for preparing the powder coated towpreg and the consolidated woven cloth panels, Mr. Scott Warrington for the computer graphics, Mr. Ruperto Razon for the unidirectional specimen preparation, and Mr. Benson Dexter for his assistance with the weaving studies and mechanical tests.

8. REFERENCES

1. J. M. Marchello and R. M. Baucom, SAMPE International Symposium, **36**, 68-80 (1991).
2. R. M Baucom and J. M. Marchello, SAMPE Q., **21** (4), 14-19 (1990).
3. D. E. Hirt, J. M. Marchello and R. M. Baucom, SAMPE International Technical Conference, **22**, 360-369 (1990).
4. B. P. Van West, R. B. Pipes, M. Keefe and S. G. Advani, Composites Manufacturing, **2** (1), 10-22 (1991).
5. S. R. Iyer and L. T. Drzal, Journal of Thermoplastic Composite Materials, **3**, 325-355 (October 1990).

TABLE I. WEAVING PARAMETERS

Towpreg Characteristics

- Yam Shape
- Amount of Twist
- Flexibility
- Degree of Damage

Weaving Characteristics

- Eyelets
- Turns and Bends
- Tenstoning
- Heddles and Reed

Final Parts

- Optimal Resin Content
- Bulk Factor

1
2
3
4
5
6
7
8
9
10
11
12
13
14
15
16
17
18
19
20
21
22
23
24
25
26
27
28
29
30
31
32
33
34
35
36
37
38
39
40
41
42
43
44
45
46
47
48
49
50
51
52
53
54
55
56
57
58
59
60
61
62
63
64
65
66
67
68
69
70
71
72
73
74
75
76
77
78
79
80
81
82
83
84
85
86
87
88
89
90
91
92
93
94
95
96
97
98
99
100

TABLE 2. TOWPREG 8HS FABRIC ANALYSIS

Material	Weave Count (ppi)	Weave Count (ppm)	Weight (g/m ²)	Thickness (cm)
G30-500 6k / LARC™-TPI, No Twist	10.2 x 9.8	402 x 386	478.4	.170
G30-500 6k / LARC™-TPI, Twisted Tow	10.2 x 9.8	402 x 386	483.7	.180
G30-500 6k / LARC™-TPI, No Twist	10.1 x 10.0	398 x 394	448.2	.196
G30-500 6k / LARC™-TPI, Twisted Tow	10.2 x 9.3	402 x 366	499.4	.262
AS-4 12k / LARC™-TPI, Twisted Tow	8.2 x 8.2	323 x 323	810.5	.320
G30-500 3k / LARC™-TPI, Twisted Tow	20.0 x 19.8	787 x 780	428.1	.147

TABLE 3. FLEXURAL RIGIDITIES

Description	Overhang (cm)	Areal Weight (mg/cm ²)	Rigidity (mg cm)
Twisted tow, 6k LARC™-TPI	10.16	8.27	1,100
Twisted woven cloth, 6k LARC™-TPI	8.26	45.02	3,200
Twisted tow, 6k LARC™-TPI	22.86	5.62	8,400
Twisted woven cloth, 6k LARC™-TPI	17.78	43.35	30,500
Twisted tow, 12k LARC™-TPI	13.97	20.85	7,100
Twisted woven cloth, 12k LARC™-TPI	10.16	87.64	11,500
Untwisted tow, 12k LARC™-TPI, 34.6% w/w resin	17.15	20.15	12,700
Untwisted tow, 12k 3M epoxy, 32%w/w resin	12.70	19.84	5,100

TABLE 4. TOW BUNDLE SIZE VS. MECHANICAL PROPERTIES IN UNIDIRECTIONAL LARC™-TPI / CARBON FIBER LAMINATES

Mechanical Properties	Yarn Bundle Size		
	3k*	6k*	12k**
Short Beam Shear Strength (MPa)	110 ± 5	79 ± 13	94 ± 5
Flexural Strength† (GPa)	1.749 ± .104	2.336 ± .149	1.757 ± .101
Flexural Modulus† (GPa)	126.0 ± 6.6	129.7 ± 3.6	107.3 ± 1.9
Transverse Flexural Strength (MPa)	112 ± 13	144 ± 21	152 ± 12

* Based on G30-500 (BASF) fibers.

** Based on AS-4 (Hercules) fibers.

† Values have been normalized for 60% fiber volume fraction.

TABLE 5. TENSION PROPERTIES OF 8HS FABRIC MADE FROM LARC™-TPI POWDER COATED TOWPREG

Tow Bundle Size	Max. Stress (MPa)	Modulus (GPa)	Poisson's Ratio	V _f (%)
6k	661 ± 38	54.7 ± 1.1	.0524 ± .0161	53
12k	464 ± 48	53.6 ± 2.6	.0559 ± .0061	47

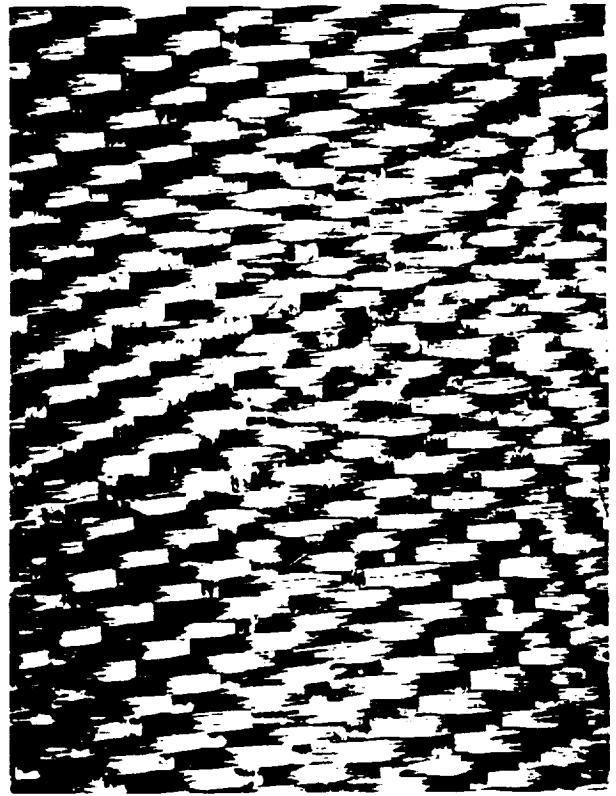

Figure 1a. Photograph of eight-harness satin cloth woven from no twist, 6k carbon fiber yarns prepregged with LARCR™-TP1 powder.

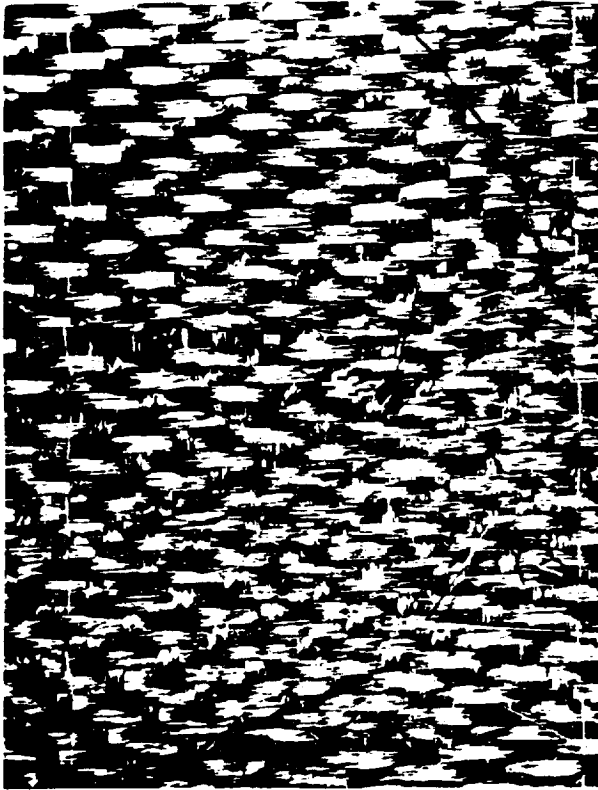
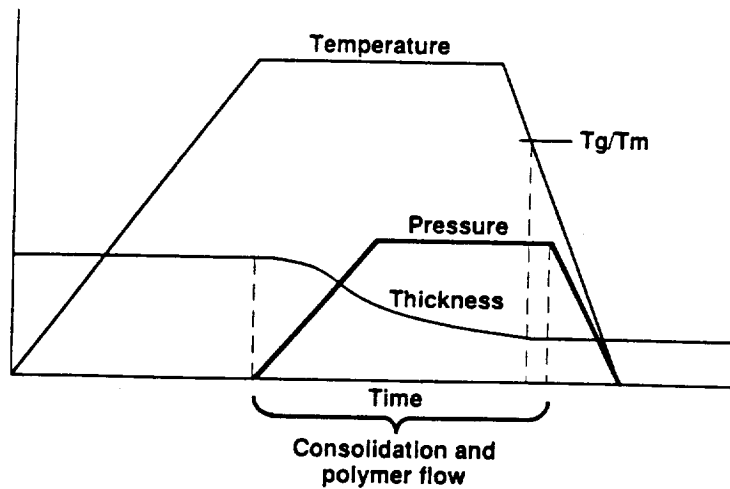

Figure 1b. Photograph of eight-harness satin cloth woven from twisted (15 twists per meter), 6k carbon fiber yarns prepregged with LARCR™-TP1 powder.

FIGURE 2. WOVEN TOWPREG CURE CYCLE



- Vacuum is used to eliminate air voids.
- Pressure ramp allows time for fiber movement into a compact arrangement with minimum fiber crimping and breakage.
- Pressure ramp also provides time for resin flow and adhesion.
- Holding temperature above T_g or T_m anneals the composite relieving fiber elastic stresses.
- Cooling below T_g or T_m stops consolidation before thickness curve flattens and avoids resin squeeze out and resulting dry spots.

DIFFERENT APPROACHES TO APPLYING RESIN TO FIBER

Joseph M. Marchello, Old Dominion University
Richard Moulton, Applied Poleramic, Inc.
Doyle Dixon, Applied Poleramic, Inc.

INTRODUCTION

Prepreg definition:

Tow
Tape
Fabric

Resin Impregnation for Manufacturing Processes

On-line:

Pultrusion, filament winding, resin transfer molding

Off-line:

Autoclave, bag molding, compression molding, pultrusion,
filament winding, tow placement

PROCEDURES/EQUIPMENT

Hot Melt
Solution
Slurry (Powder)
Dry Powder
Electrochemical Polymerization/Deposition
Vapor Phase Polymerization/Deposition

PRECONSOLIDATION

Resin Flow
Wetting
Voids
Web Elasticity
Thermoset Cure

PROCESS SELECTION

Thermosets
Thermoplastics
Manufacturing Method

PREPREG METHODS

SOLUTION - Polymer is dissolved in a solvent and fiber tow impregnated with the low-viscosity solution. Requires removal of solvent after impregnation. Limited to polymer/solvent systems.

SLURRY - Polymer particles are suspended in a liquid and fiber tow impregnated with particles. Requires carrier liquid removal after impregnation. Limited by need for uniform suspension of particles.

HOT MELT - Fiber is impregnated with molten polymer in a resin bath, between nip rollers or by extruder feeding of molten polymer into a die though which the fiber rovings pass. Requires low viscosity polymer melts or high forces on fibers which may cause damage.

FILM STACKING - Unidirectional fiber tows or woven fabrics stacked with plastic sheets and compressed. Labor intensive, requires high flow resins or high pressure. Difficult to wet out tow filaments with high molecular weight plastics.

FIBER CO-MINGLING - Polymer spun into yarn and mingled with reinforcing fiber tow. Limited by cost of spinning polymer into yarn fibers.

DRY POWDER - Polymer powder is introduced into fiber tow and heat sintered to fibers. Fluidized or loosely packed powder bed. Thermoplastic and thermoset powders may be used. Concerns are with uniformity of powder coating.

RESIN IMPREGNATION FOR MANUFACTURING

ON-LINE:

PULTRUSION

FILAMENT WINDING

RESIN TRANSFER MOLDING

OFF-LINE:

AUTOCLAVE

BAG MOLDING

COMPRESSION MOLDING

PULTRUSION

FILAMENT WINDING

TOW PLACEMENT

PREPREG TYPES

TOW - Single fiber tows impregnated with polymer matrix. Yarn or ribbon

TAPE - Unidirectional array of fiber tows impregnated with polymer. Tapes range in width up to several meters.

FABRIC - Woven and braided tows. May be impregnated with polymer before or after fabrication.

DEFINITIONS

Fiber Volume Fraction - The portion, measured by volume, of a composite that is fiber. If a composite is made of only two materials, fibers and resin, and there are no voids, then the density of the composite is given by

$$\rho_c = \rho_f V_f + \rho_r V_r,$$

where V_f is the volume fraction of fiber. Fiber volume is typically measured in two ways. 1) A strong acid or base is used to remove resin, leaving only fibers. 2) By optical microscopy / image analysis, a line or area method is used to extrapolate the volume fraction of fiber and resin.

Fiber Areal Weight - The weight of fiber per unit area (g/m^2). In a fabric made of only fibers, a representative area is cut from the fabric and weighed. For prepreg, a representative area is cut, the resin is digested by means of a strong acid or base, and the remaining fibers are weighed. Directly related to volume fraction.

Tow† - A loose essentially untwisted strand of synthetic fibers.

† [Webster's Ninth New Collegiate Dictionary](#), Merriam-Webster.



Tow Filament Count^{††} - The number of individual filaments that make up a thread of yarn. e.g. 1000, 3000, 6000, 12,000, ... filaments per tow.

Fiber Diameter

Carbon:	7 micrometers	AS-4
	5 micrometers	IM-7
Glass:	10 μm	E- and S-glass
Kevlar [™] :	12 μm	

Fabric^{††} - A planar textile structure produced by interlacing yarns, fibers, or filaments. e.g. Plain, Twill and Satin Weaves (5 and 8 harness satin), and Soutache, Tubular and Flat Braids.

Fabric Count ^{††} - The number of warp yarns (ends) and filling yarns (picks) per inch in a woven fabric, or the number of wales and courses per inch in a knit fabric. e.g. For woven fabrics, 68 x 52 indicates 68 ends per inch in the warp and 52 picks per inch in the filling direction.

^{††} Man-made Fiber and Textile Dictionary, Celanese Corporation.

FIBER VOLUME

Find fiber volume that gives best composite properties and use.

Fiber volume is established during prepregging

In General: Unitape, unidirection composites, require smaller amounts of resin resulting in fiber volumes as high as 65%. Angle-ply unitape composite and fabric composites need more resin to fill cross-fiber spaces resulting in lower optimum fiber volumes.

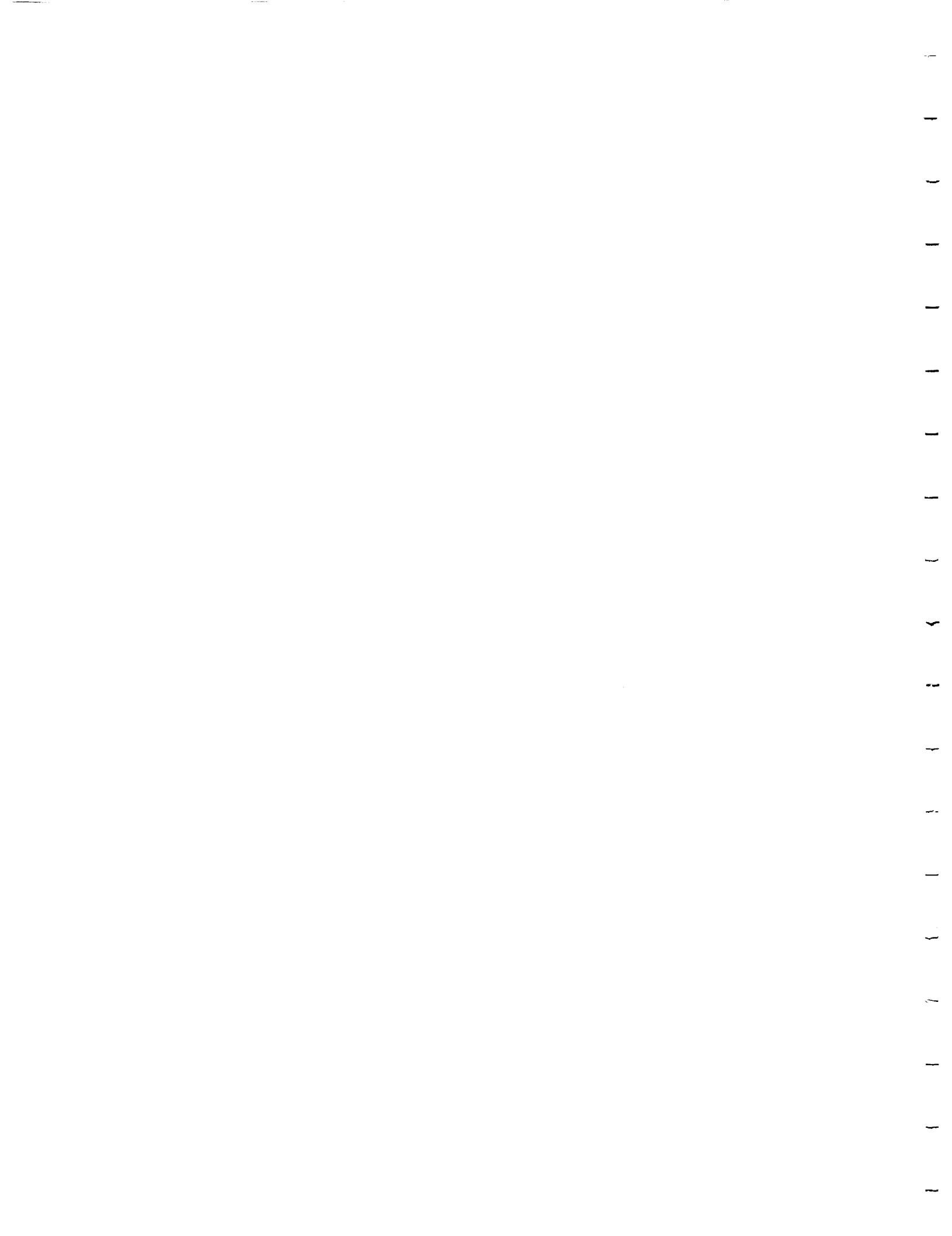

CHALLENGES/BARRIERS IN CURRENT PREPREG TECHNOLOGY

Toughened epoxy prepreg and towpreg

- Short out-times
- High scrap losses
- Refrigeration
- Expensive

Thermoplastic Matrices

- Difficult to hot-melt or solution coat
- Expensive

Solution Prepregging

- Handling solvents

Commingle Yarns

- Expensive

RTM Matrices

- Environmental Stability

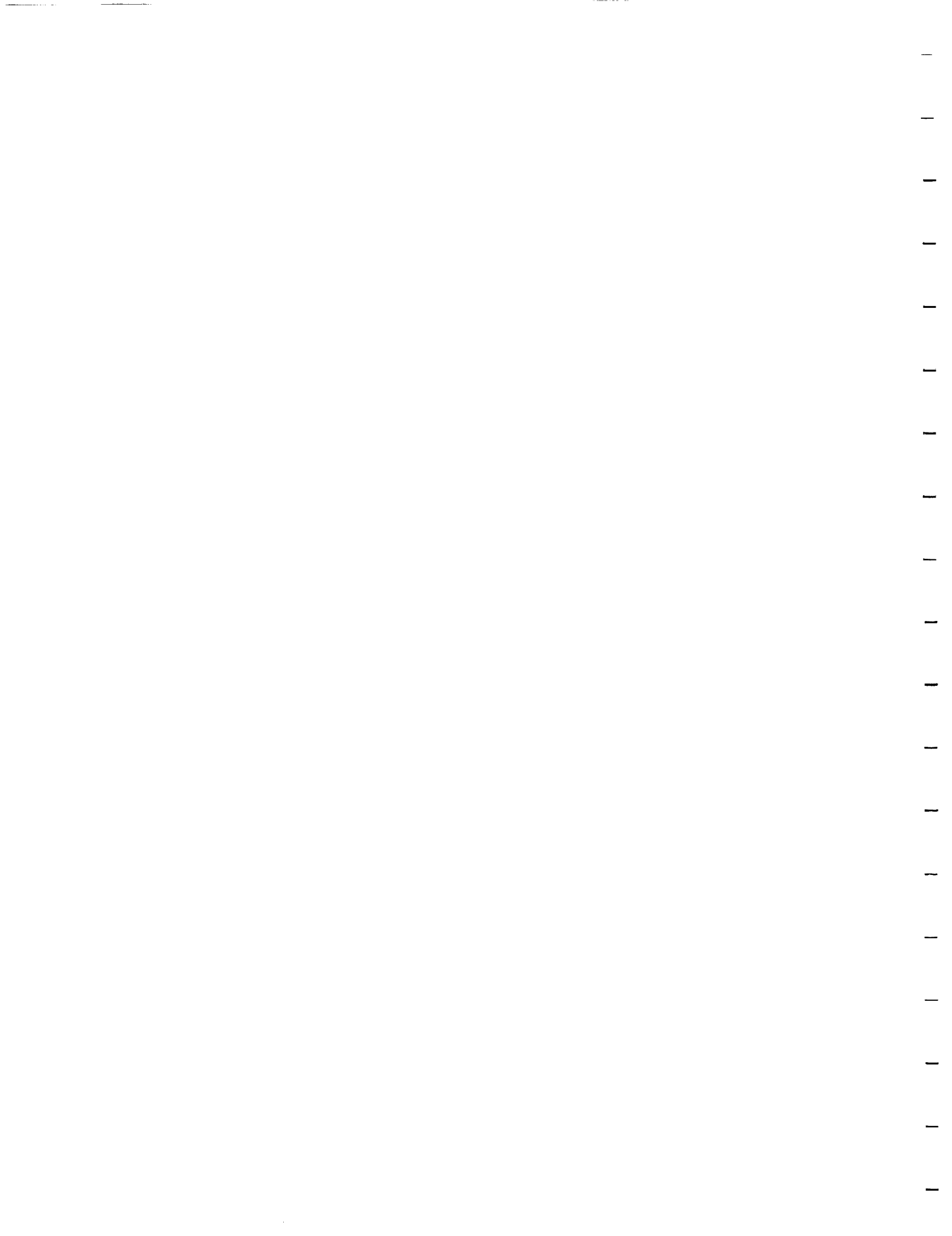

**PROCEDURES
AND EQUIPMENT**

HOT MELT

SOLUTION

SLURRY (POWDER)

DRY POWDER

**ELECTROCHEMICAL
POLYMERIZATION**

VAPOR PHASE DEPOSITION

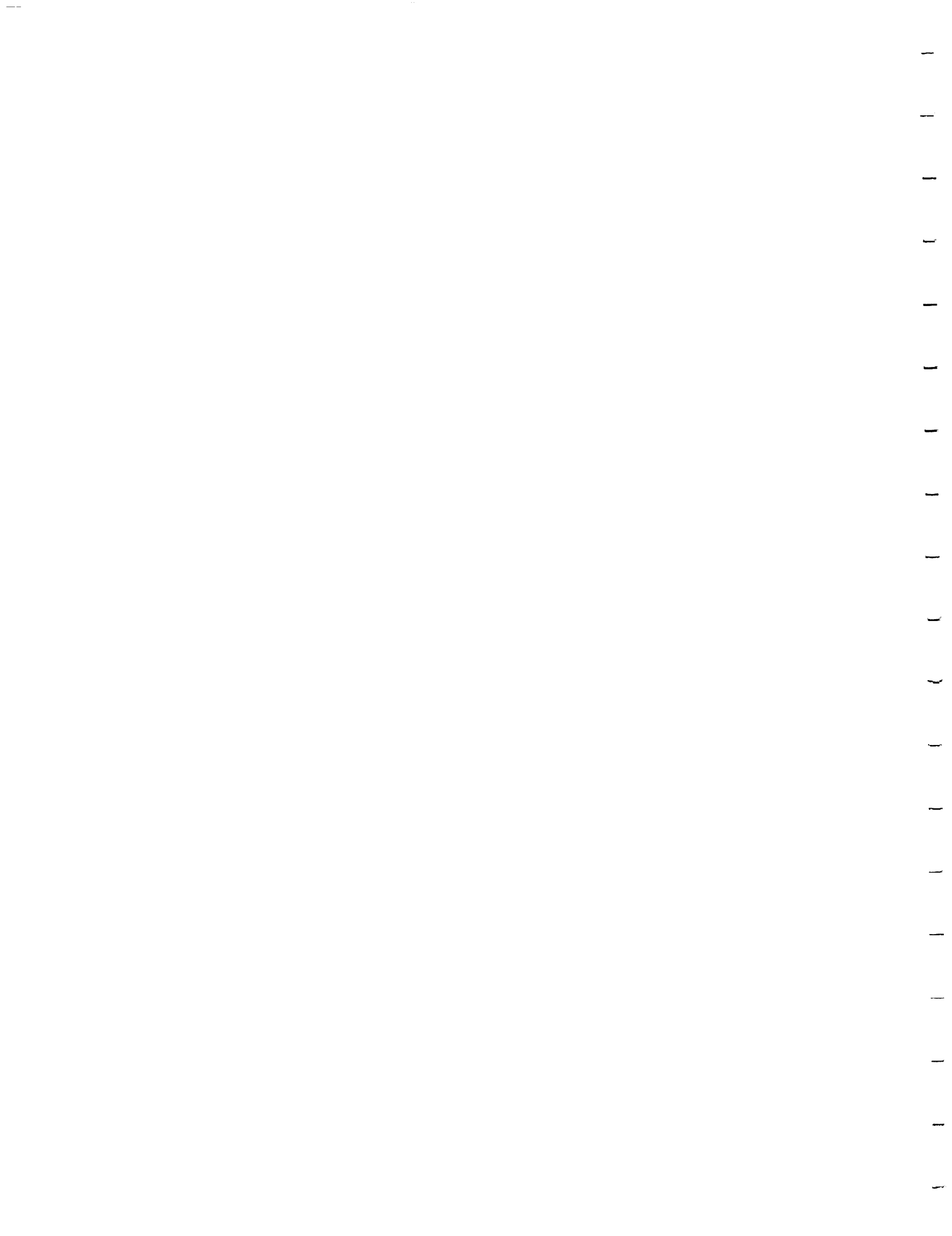

HOT MELT PREPREGGING

- Cast film onto release paper from molten material using reverse roll coater or knife-over-plate coater.
- Run fiber onto coated paper, cover with second release paper and run this sandwich into nip roll.
- Remove top paper and wind roll

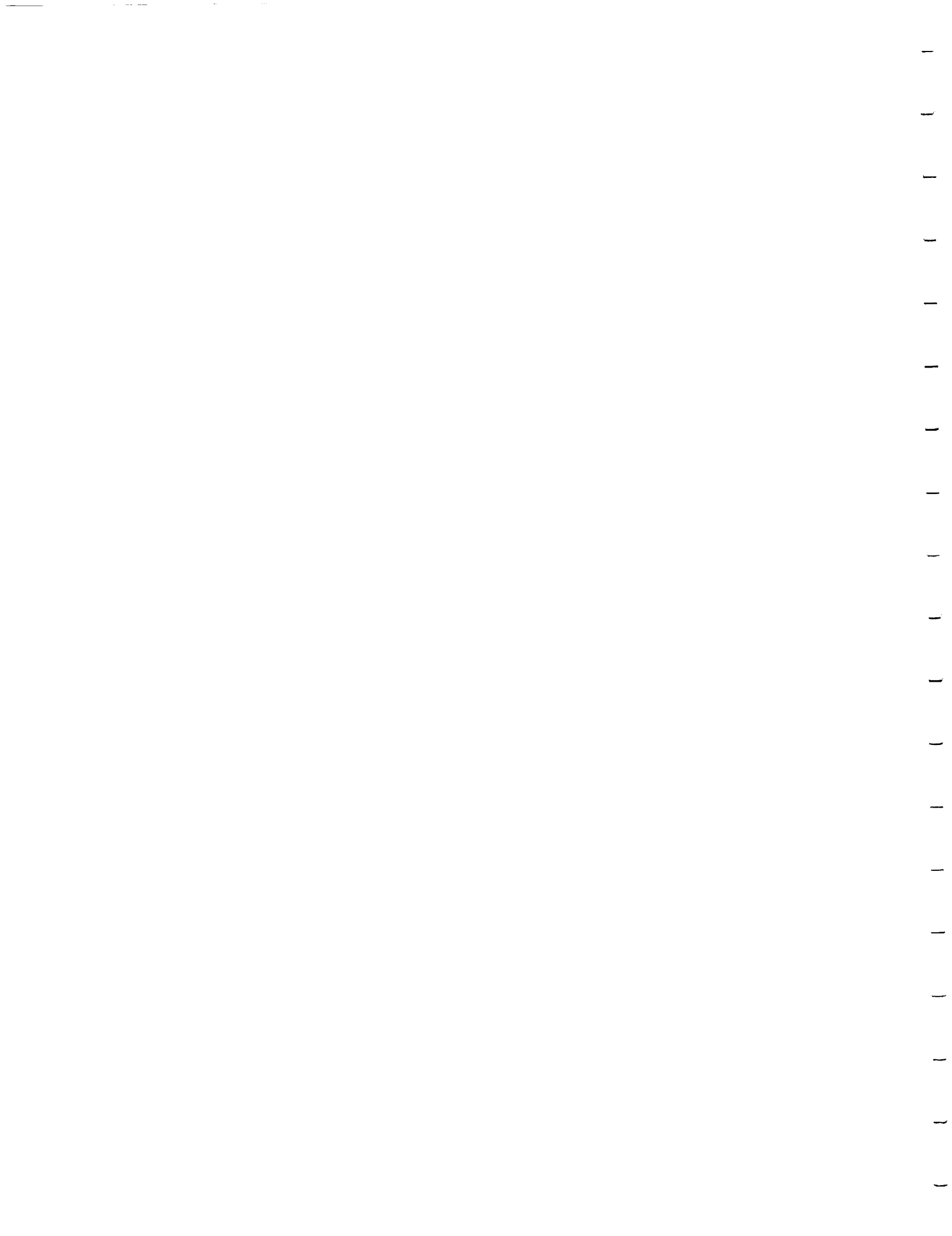

SOLUTION AND SLURRY PREPREGGING

- Viscosity/solids concentration/density relationship
- Film high viscosity solution onto release paper or run fibers through dip tank and onto release paper, or
use both of the above to achieve proper resin control.
- Cover with top paper and pass into nip roller
- Remove both papers for solvent devolatilization in oven or heat source
- Add carrier paper (optional)

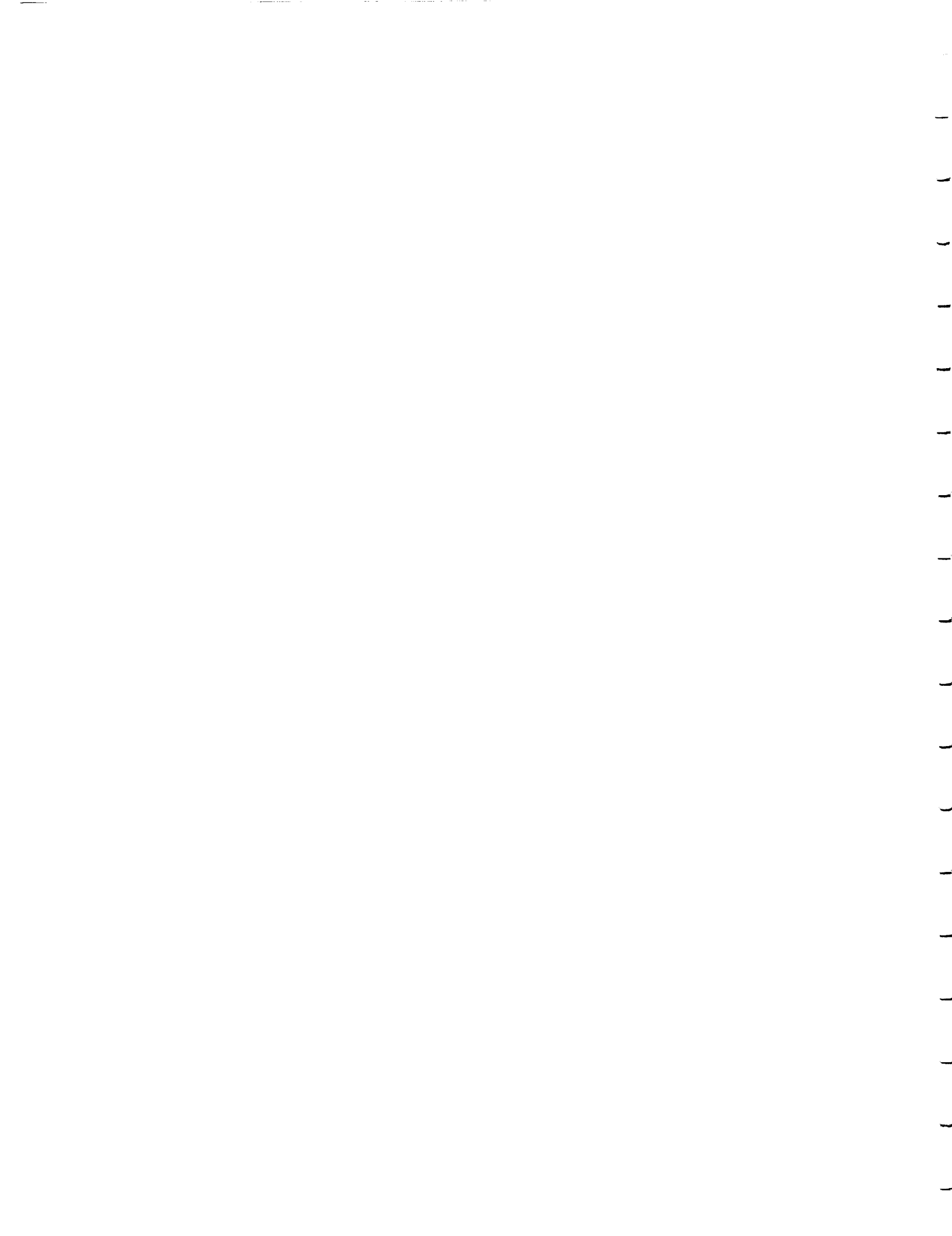

CALENDERING

- Through the thickness of the fiber bundle
- Nip roll pressure may exceed 100 atmospheres
- Sheet speeds up to 2 m/sec
- Compression time intervals as short as 0.01 seconds

DIE FORMING

- Die pressures up to about 10 atm.
- Pulling rates as high as 2 m/sec with ultrasonics
- Pressure time intervals as short as 0.25 seconds

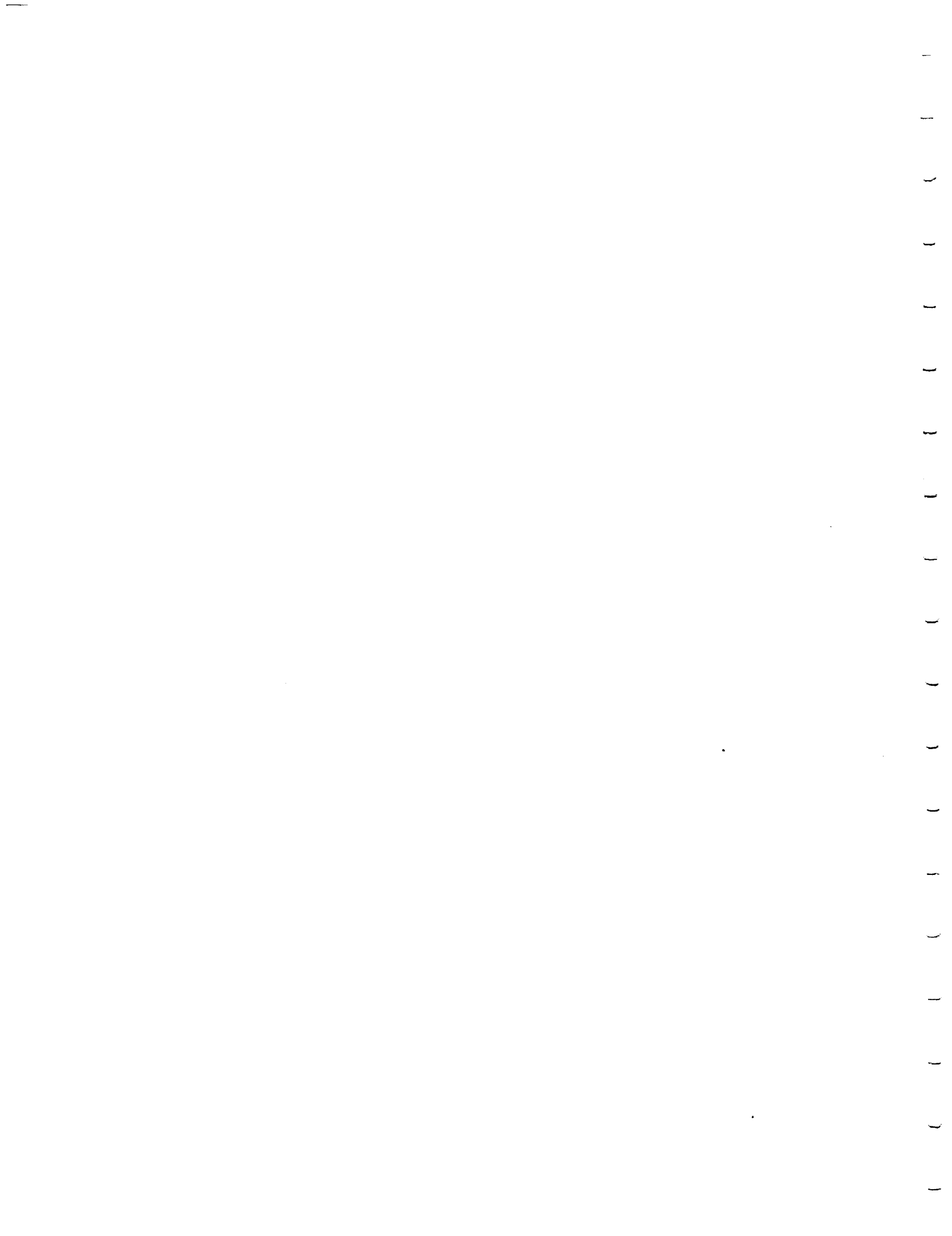

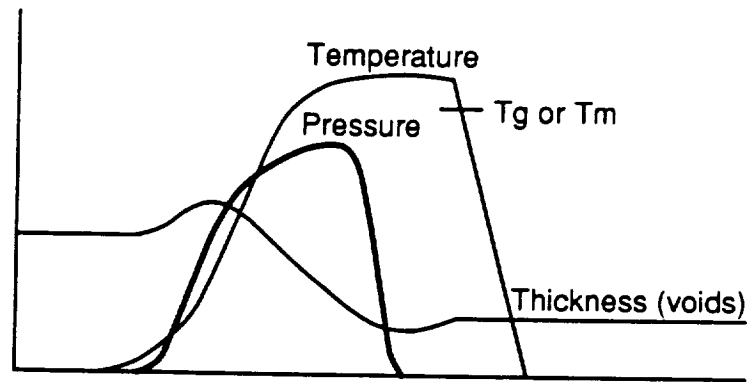
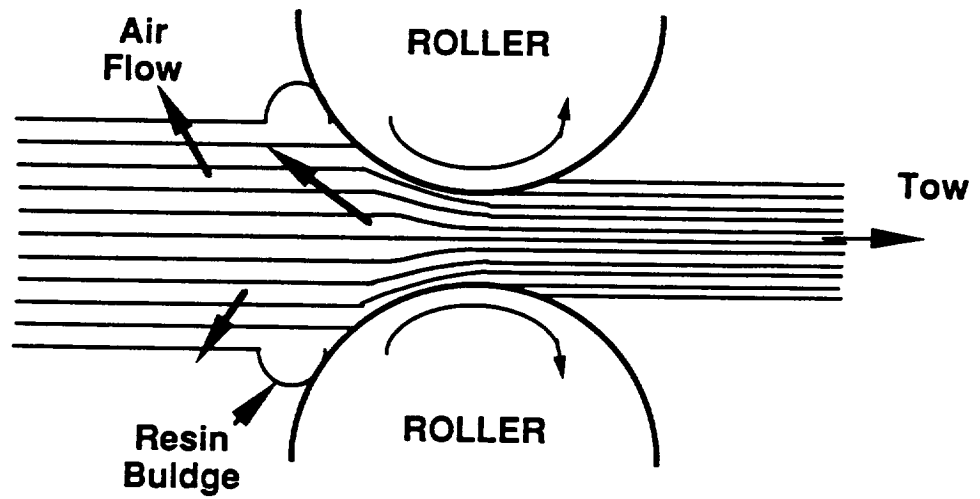

Cold Tape and Hot Rollers

NIP ROLLER CONSOLIDATION CYCLE



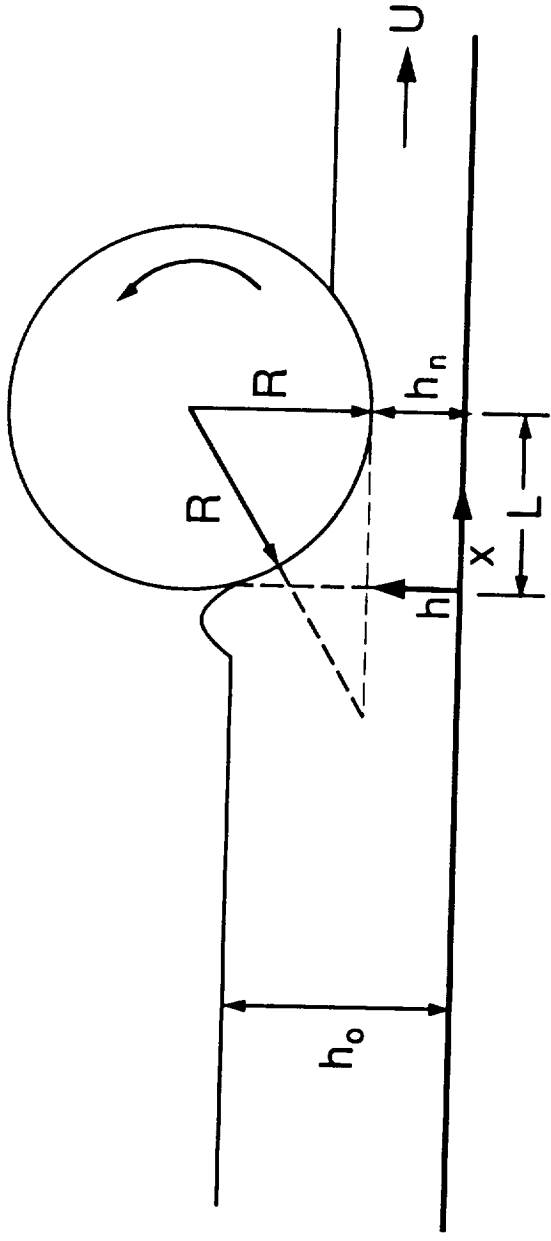

$$h = h_n + (L - x)^2 / 2R$$

$$P = 4 \mu UR (h_0 - h_n) / gh^2$$

for $x \geq 0$

where: μ is the viscosity

g is the gravitational constant

ROLLER PRESSURE AND PREPREG THICKNESS



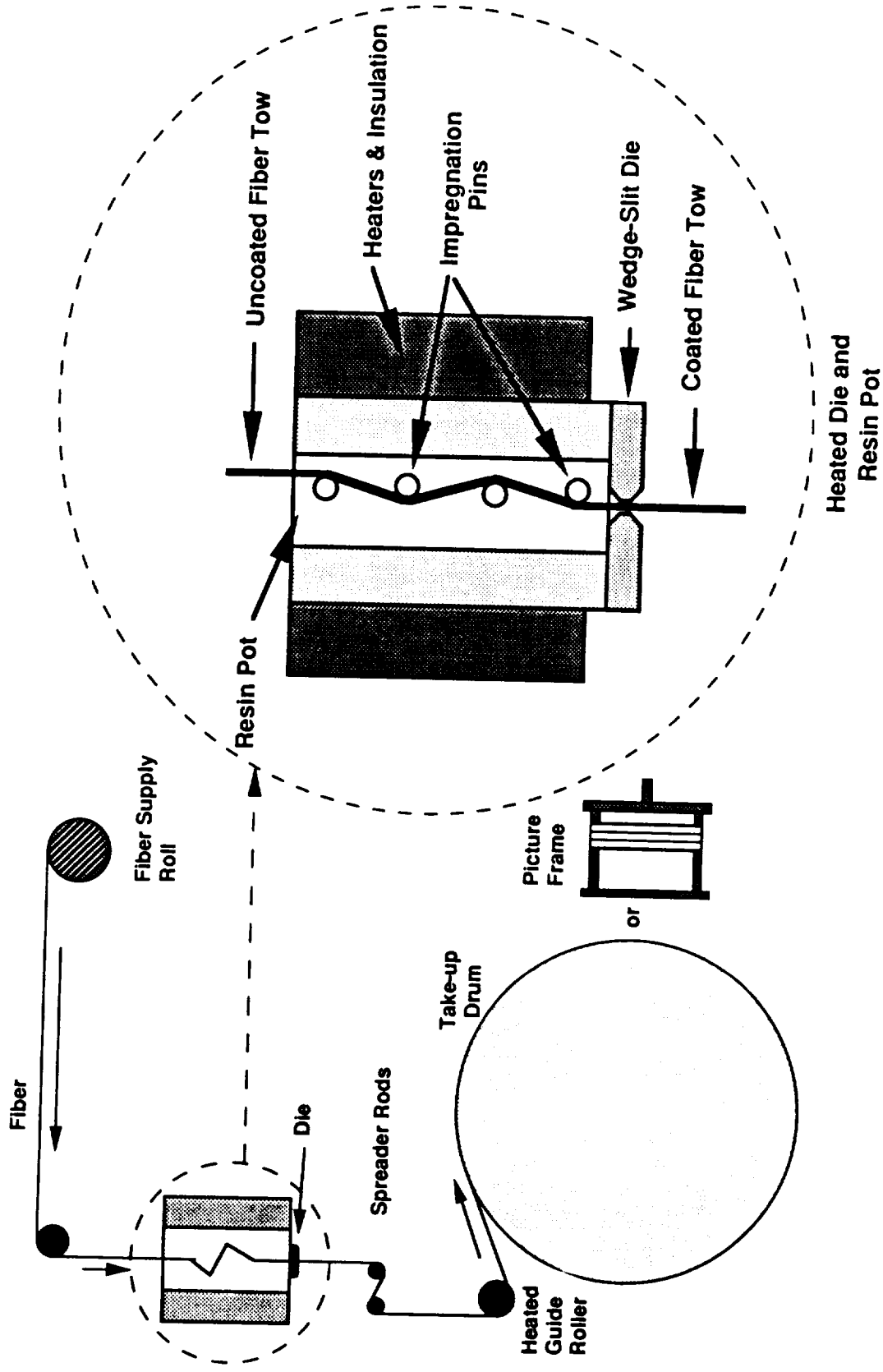

Single tow solution prepregging systems

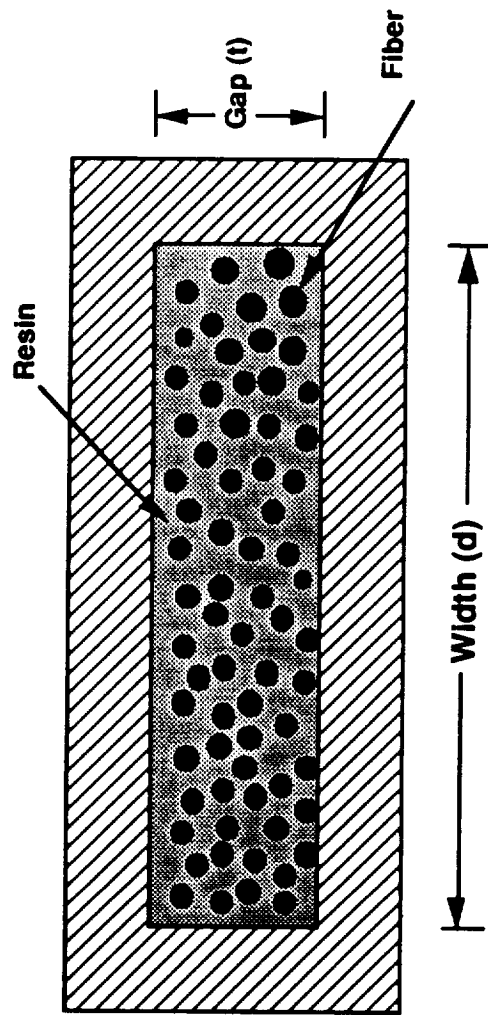

Cross-section schematic of the die opening, showing fibers and resin

SOLUTION PREPREGGING

The mass fraction of the solution in the prepreg is determined primarily by the cross sectional areas and densities:

$$\frac{m_s}{M_T} = \frac{(td - A_f)\rho_s}{(td - A_f)\rho_s + A_f\rho_f}$$

and the corresponding percent dry resin content is:

$$\frac{m_r}{M_T} = \frac{S(td - A_f)\rho_s}{s(td - A_f)\rho_s + A_f\rho_f}$$

where $S = 100 s$, resin solids in the solution, %.

The calculated dry resin content from this relation was compared to measured values for several systems and fit by the following equation which reflects the effects of viscosity and surface tension. It may be used to calculate the resin content, or through the above relationship the die size for a given resin content.

$$\left(\frac{m_r}{M_T}\right) = 0.34307 + 0.89121\left(\frac{m_r}{M_T}\right)_{\text{calc}}$$

CONVENTIONAL PREPREGGING MACHINES

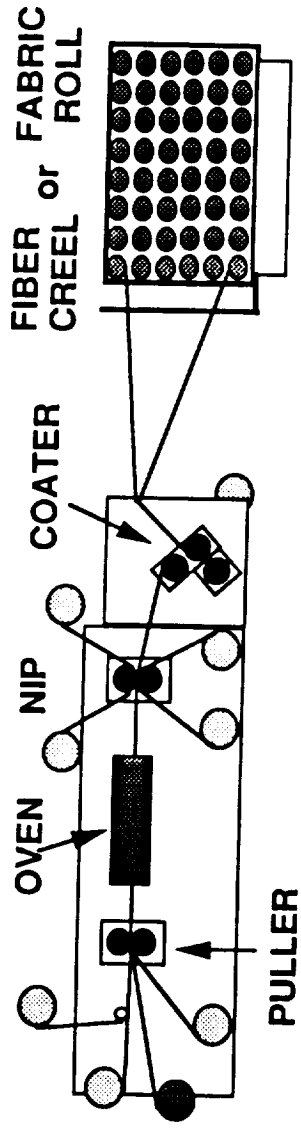

COATER OPTIONS

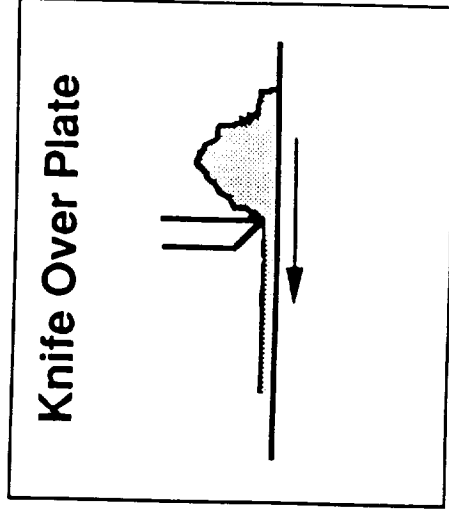
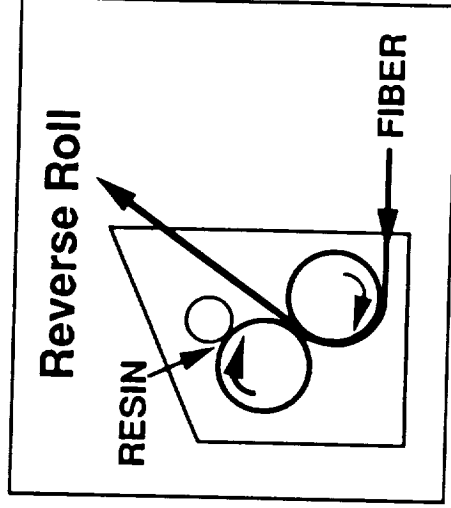
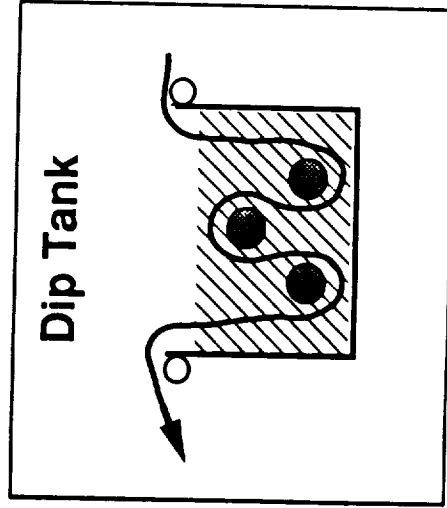



PREPREG CALCULATIONS

VARIABLE DEFINITIONS

FAW = DRY FIBER AREAL WT. (g/m²)

RAW = DRY RESIN AREAL WT. (g/m²)

PAW = DRY PREPREG AREAL WT. (g/m²)

(PAW)_{WET} = PREPREG AREAL WT WITH VOLATILES (g/m²)

w_{f1} = FIBER WEIGHT FRACTION OF PAW OR (PAW)_{WET}

w_m = MATRIX WEIGHT FRACTION OF PAW OR
(PAW)_{WET}

w_{SOLVENT} = SOLVENT WEIGHT FRACTION OF (PAW)_{WET}

w_{SOLID} = SOLID WEIGHT FRACTION OF SOLUTION,
i.e. 40% SOLID SOLUTION

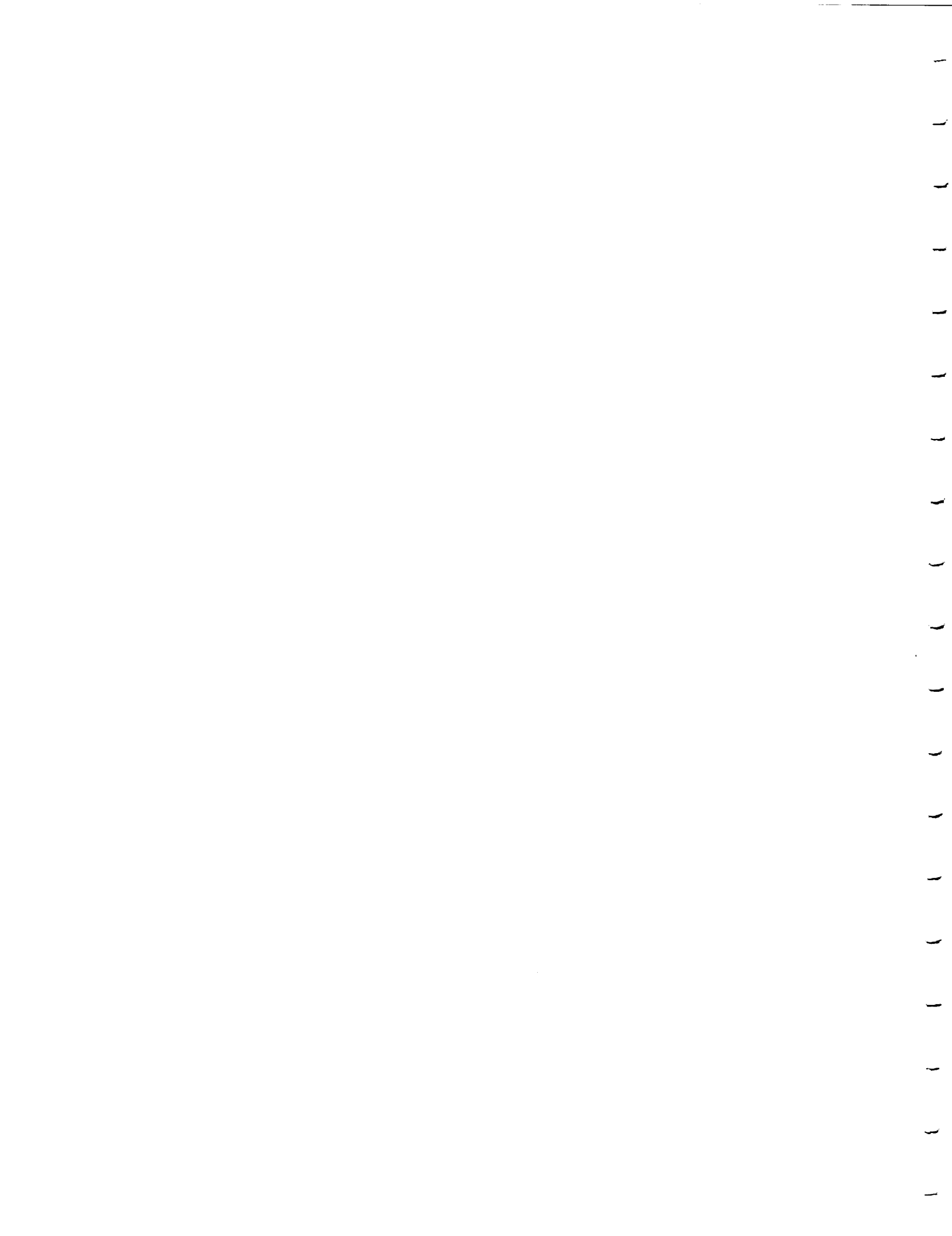

t = DRY PREPREG THICKNESS (cm)

$(t)_{\text{WET}}$ = PREPREG THICKNESS WITH VOLATILES
(cm)

ρ_c = PREPREG DENSITY (g/cm^3)

$(\rho_c)_{\text{WET}}$ = PREPREG DENSITY WITH VOLATILES
(g/cm^3)

ENDS = # OF SPOOLS OF FIBER

y = FIBER YIELD (g/m) i.e., 3K, 6K, 12K, Glass,
Carbon, Kevlar

w = PREPREG WIDTH



PRE-CAST FILMS

FILM THICKNESS FOR DOUBLE SIDE COATING

$$t_{film} = \frac{RAW}{2 (100)^2 (\rho_m)} = cm$$

double side coating

$$(t_{film})_{WET} = \frac{(RAW)_{WET}}{2 (100)^2 (\rho_{SOL})_{WET}}$$

WHERE: $\rho_{SOLUTION} = \frac{1}{\frac{w_{SOLID}}{\rho_m} + \frac{w_{SOLVENT}}{\rho_{SOLVENT}}}$

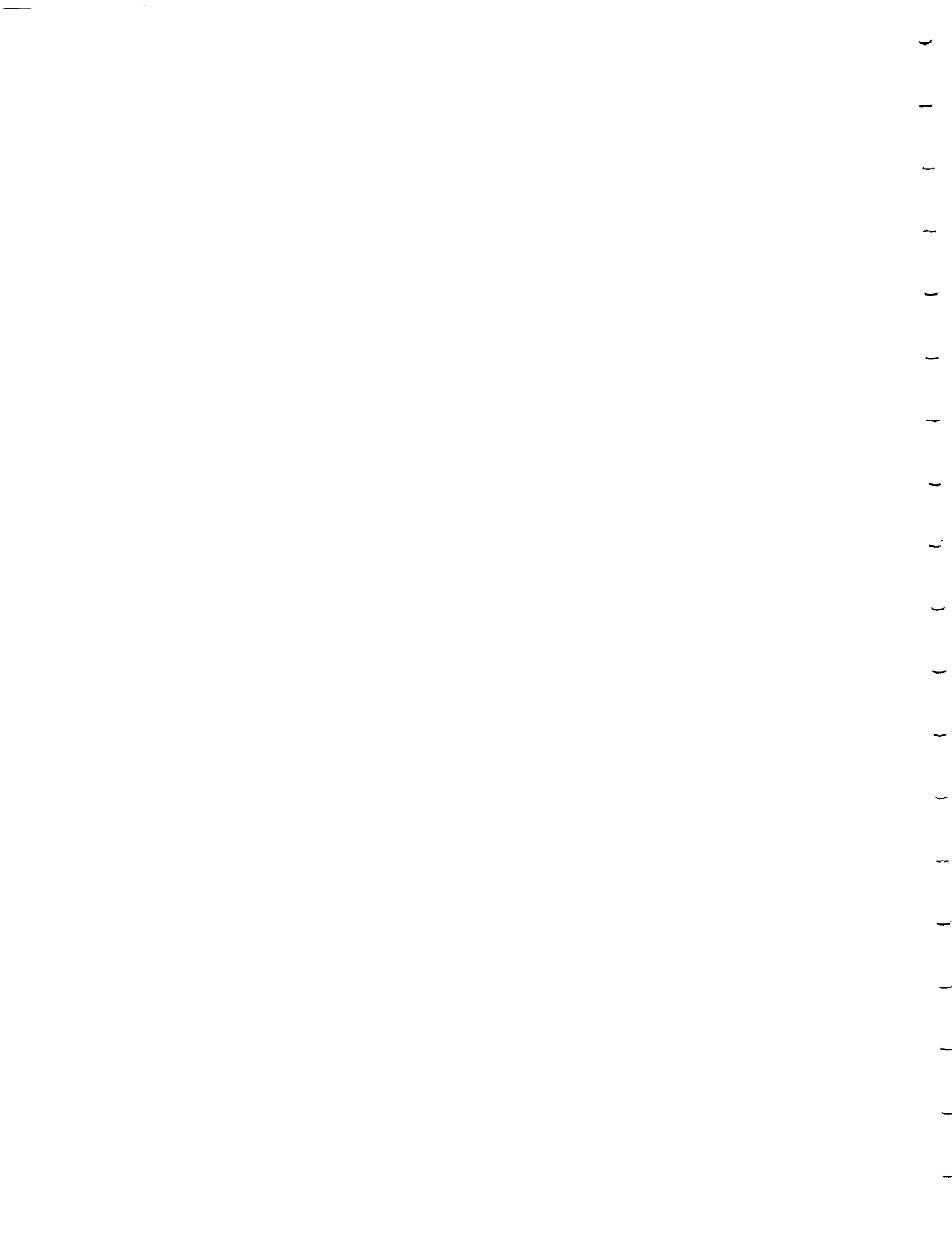

$$ENDS = \frac{FAW \times W}{39.37 \times Y}$$

$$PAW = \frac{FAW}{1 - w_m}$$

$$(PAW)_{WET} = FAW \left(\frac{w_m}{(1 - w_m) w_{SOLID}} + 1 \right)$$

$$RAW = PAW - FAW$$

$$(RAW)_{WET} = (PAW)_{WET} - FAW$$

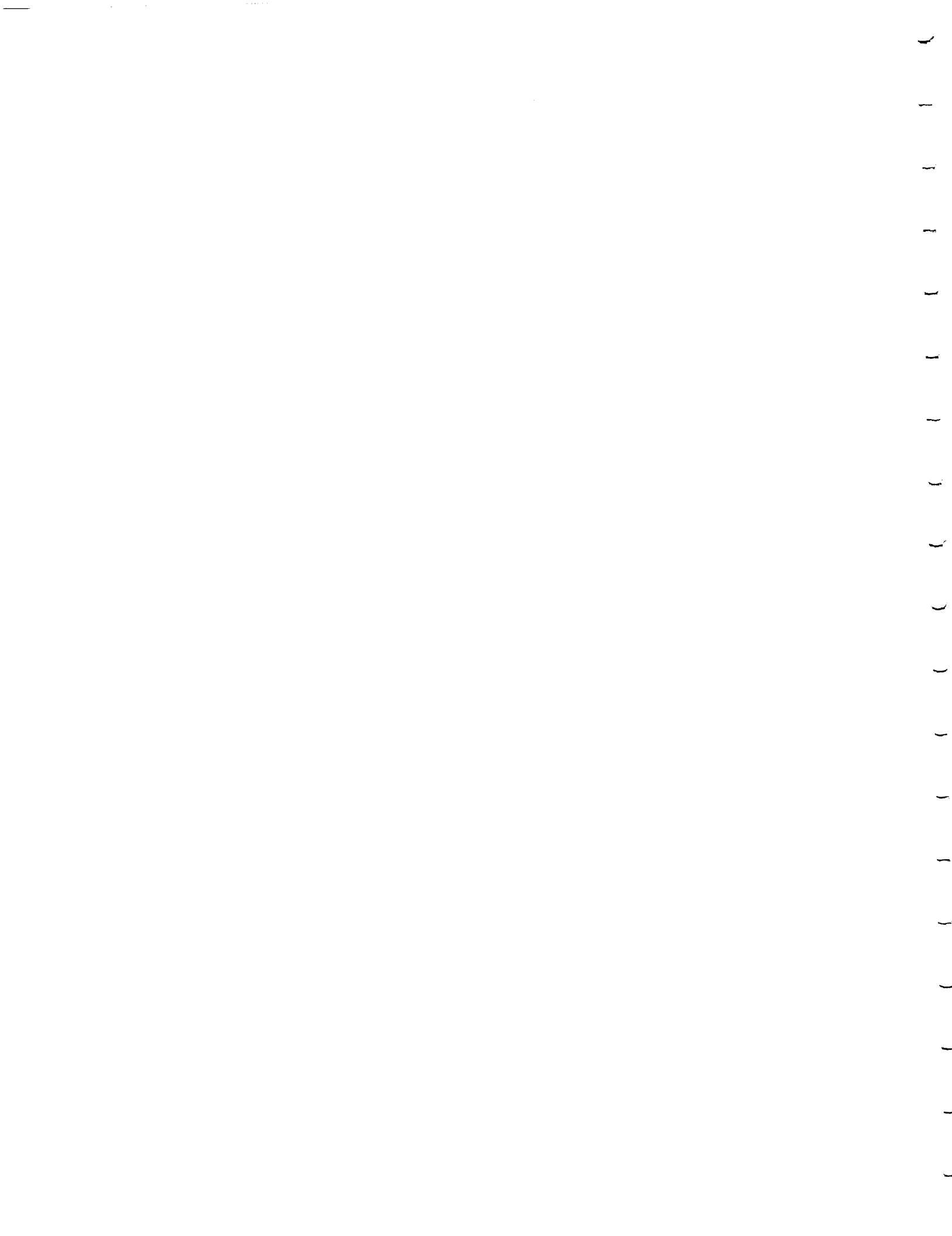

$$\rho_c = \frac{1}{\frac{w_f}{\rho_f} + \frac{w_m}{\rho_m}}$$

WHERE: ρ_f = FIBER DENSITY
 ρ_m = MATRIX DENSITY
 w_f & w_m = WEIGHT FRACTION OF DRY PREPREG

$$(\rho_c)_{WET} = \frac{1}{\frac{w_f}{\rho_f} + \frac{w_m}{\rho_m} + \frac{w_{SOLVENT}}{\rho_{SOLVENT}}}$$

WHERE:

$$w_f = \frac{FAW}{(PAW)_{WET}}$$

$$w_m = \frac{RAW}{(PAW)_{WET}}$$

$$w_{SOLVENT} = 1 - w_f - w_m$$

$$\rho_{SOLVENT} = \text{SOLVENT DENSITY}$$

$$t = \frac{PAW}{\rho_c (100)^2}$$

$$(t)_{WET} = \frac{(PAW)_{WET}}{(\rho_c)_{WET} (100)^2}$$

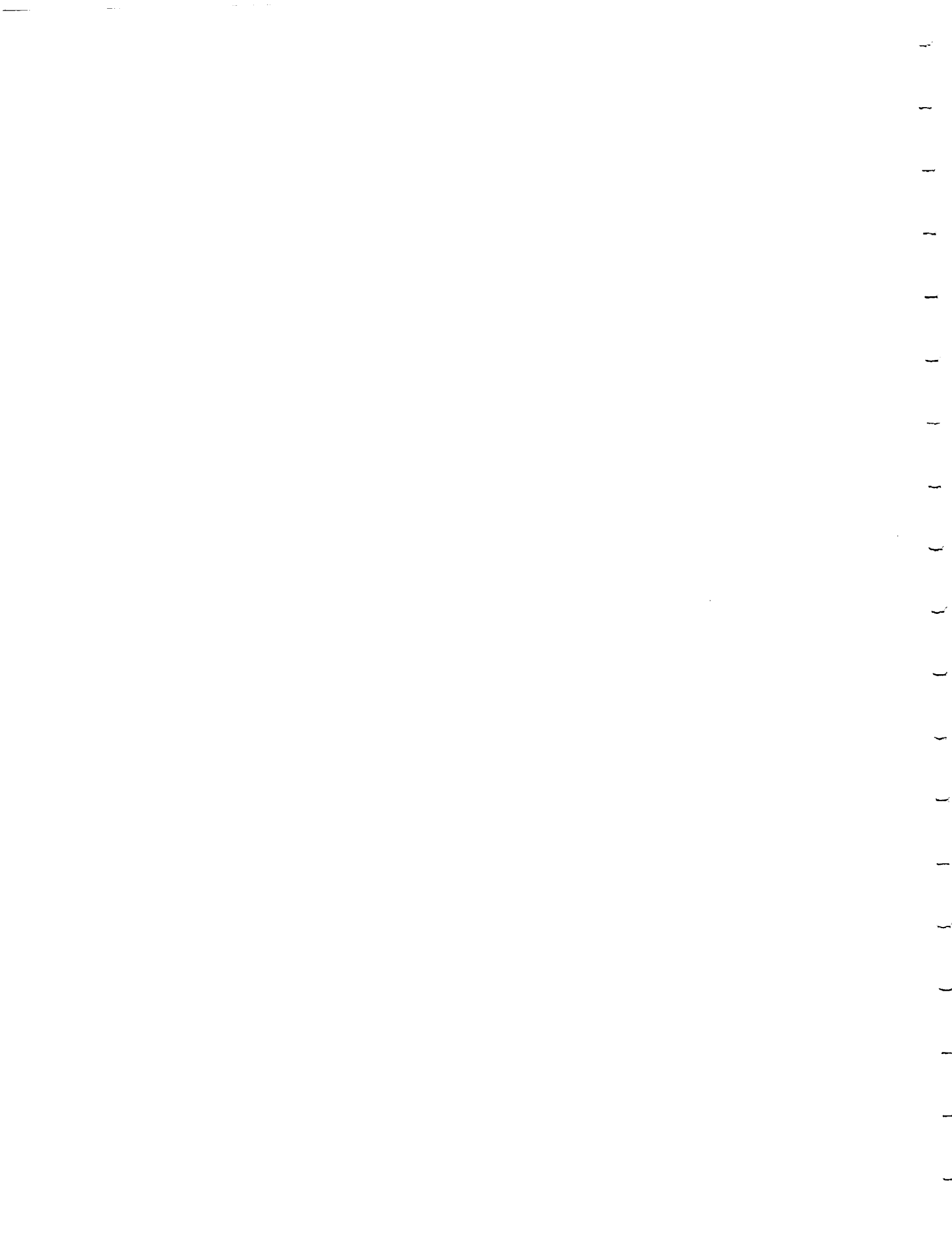

EXAMPLE

$$\begin{aligned} \text{FAW} &= 145 \text{ g/m}^2 \\ w_m &= 35\% \text{ or } .35 \\ \rho_m &= 1.25 \text{ g/cm}^3 \end{aligned}$$

$$PAW = \frac{145 \text{ g/m}^2}{1 - .35} = 223 \text{ g/m}^2$$

$$RAW = 223 \text{ g/m}^2 - 145 \text{ g/m}^2 = 78 \text{ g/m}^2$$

$$t_{film} = \frac{78 \text{ g/m}^2}{2 (100)^2 (1.25 \text{ g/cm}^3)} = .00312 \text{ cm}$$

.0012 in

COATER CAP SETTING IS TYPICALLY TWICE THE FILM THICKNESS TO COMPENSATE FOR THE SHEAR.

$$\therefore \text{GAP SETTING} = 2 (.0012 \text{ IN}) = .0024 \text{ IN}$$



FILM WEIGHTS VARY DUE TO:

1. MATRIX VISCOSITY
2. ROLL RUN-OUT
3. ROLL TEMPERATURE
4. LINE FEED
5. APPLICATOR ROLL SPEED

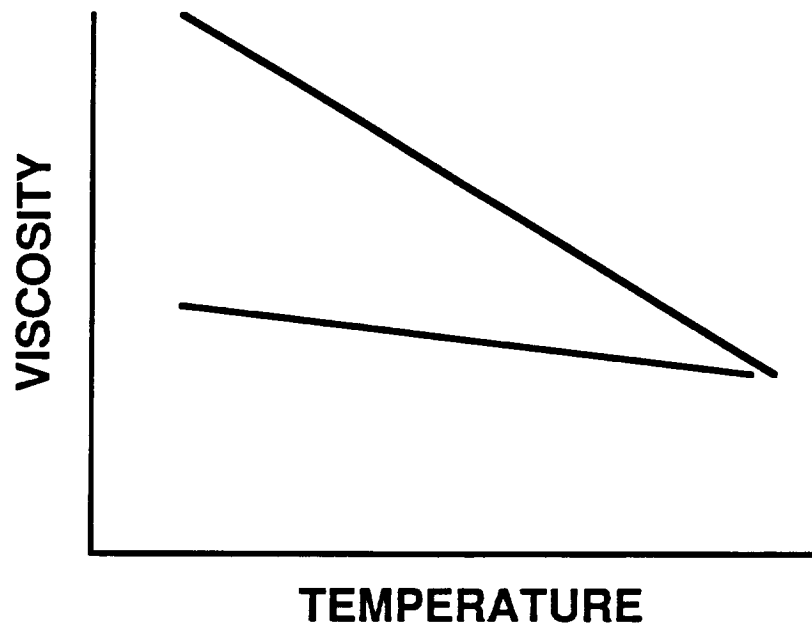

LOWER CURVE DEMONSTRATES A MORE OPTIMUM
CASTING RESIN.
(LESS SENSITIVE TO TEMPERATURE VARIATIONS)

FILM TOLERANCES

$$\text{FAW} = 145 \text{ F/M}^2$$

$$w_m = 35\% \pm 3\%$$

$$\rho_m = 1.25 \text{ g/cm}^3$$

$$\rho_f = 1.8 \text{ g/cm}^3$$

TYPICAL

$$.0027 \text{ cm} < t_{\text{film}} < .00355 \text{ cm}$$

$$.0011 \text{ in} < t_{\text{film}} < .0014 \text{ in}$$

- * ROLL RUN-OUT AND DEFLECTIONS MUST BE LESS THAN TWICE THE SPREAD OF .0003 IN
- STRESSES THE ACCURACY OF FILMING ROLLS



NIP ROLL GAP

ASSUME: 100% WET-OUT PREPREG
NO SOLVENTS PRESENT

$$t = PAW / \rho_c (100)^2$$

$$\rho_c = \frac{1}{\frac{w_f}{\rho_f} + \frac{w_m}{\rho_m}}$$

EXAMPLE:

$$\begin{aligned} \text{FAW} &= 145 \text{ g/m}^2 \\ w_m &= 35\% \\ \rho_m &= 1.25 \text{ g/cm}^3 \\ \rho_f &= 1.8 \text{ g/cm}^3 \end{aligned}$$

$$\text{PAW} = 145 \text{ g/m}^2 / 1 - .35 = 223 \text{ g/m}^2$$

$$\rho_c = \frac{1}{\frac{.65}{1.8} + \frac{.35}{1.25}} = 1.56 \text{ g/cm}^3$$

$$\begin{aligned} t &= \frac{223 \text{ g/m}^2}{(1.56 \text{ g/cm}^3) (100 \text{ g/m})^2} = .0143 \text{ cm} \\ &= .0056 \text{ in} \end{aligned}$$

* NIP GAP SETTING SHOULD BE SET AT .0056 IN MINIMUM.



DIP-PAN METERING

ASSUME:

1. SPECIFIC GRAVITY OF SOLUTION FOLLOWS THE RULE OF MIXTURES.
2. NO SHEAR EFFECTS DUE TO VISCOSITY CHANGES (CONSTANT FLOW PROFILE THROUGH METERING RODS)

$$t_{WET} = \frac{(PAW)_{WET}}{(\rho_C)_{WET} (100)^2}$$

1
2
3
4
5
6
7
8
9
10
11
12
13
14
15
16
17
18
19
20
21
22
23
24
25
26
27
28
29
30
31
32
33
34
35
36
37
38
39
40
41
42
43
44
45
46
47
48
49
50
51
52
53
54
55
56
57
58
59
60
61
62
63
64
65
66
67
68
69
70
71
72
73
74
75
76
77
78
79
80
81
82
83
84
85
86
87
88
89
90
91
92
93
94
95
96
97
98
99
100

EXAMPLE:

$$\begin{aligned}FAW &= 145 \text{ g/m}^2 \\w_m &= 35\% \\ \rho_f &= 1.8 \text{ g/cm}^3 \\ \rho_m &= 1.25 \text{ g/cm}^3 \\ \rho_{\text{SOLVENT}} &= 1.07 \text{ g/cm}^3 \\ w_{\text{SOLID}} &= 40\% \text{ SOLID SOLUTION}\end{aligned}$$

$$\begin{aligned}(PAW) &= FAW \left(\frac{w_m}{(1 - w_m) w_{\text{SOLID}}} + 1 \right) \\ &= 145 \text{ g/m}^2 \left(\frac{.35}{(1 - .35) (.40)} + 1 \right) \\ &= 340 \text{ g/m}^2\end{aligned}$$

$$(\rho_c)_{\text{WET}} = \frac{1}{\frac{w_f}{\rho_f} + \frac{w_m}{\rho_m} + \frac{w_{\text{SOLVENT}}}{\rho_{\text{SOLVENT}}}}$$

$$w_f = \frac{145}{340} = .426$$

$$w_m = \frac{RAW}{(PAW)_{\text{WET}}} = \frac{78 \text{ g/m}^2}{340 \text{ g/m}^2} = .230$$

$$w_{\text{SOLVENT}} = 1 - .426 - .230 = .344$$

WHERE:

$$\begin{aligned}RAW &= PAW - FAW \\ &= \frac{FAW}{1 - w_m} - FAW \\ &= \frac{145}{1 - .35} - 145 \\ &= 78 \text{ g/m}^2\end{aligned}$$

$$\begin{aligned}(\rho_c)_{WET} &= \frac{1}{\frac{.426}{1.8} + \frac{.23}{1.25} + \frac{.344}{1.07}} \\ &= 1.35 \text{ g/cm}^3\end{aligned}$$

$$\begin{aligned}(t)_{WET} &= \frac{340 \text{ g/m}^3}{(1.35 \text{ g/cm}^3) (100)^2} = .0252 \text{ cm} \\ &= .0099 \text{ in}\end{aligned}$$

* METERING ROD GAP = .0099 IN

1
2
3
4
5
6
7
8
9
10
11
12
13
14
15
16
17
18
19
20
21
22
23
24
25
26
27
28
29
30
31
32
33
34
35
36
37
38
39
40
41
42
43
44
45
46
47
48
49
50
51
52
53
54
55
56
57
58
59
60
61
62
63
64
65
66
67
68
69
70
71
72
73
74
75
76
77
78
79
80
81
82
83
84
85
86
87
88
89
90
91
92
93
94
95
96
97
98
99
100

IMPREGNATION FACTORS

1. RESIN VISCOSITY AND WETABILITY
2. TEMPERATURE
3. PRESSURE
4. INDUCTION TIME
5. FIBER TYPE
 - a. Micron Size of Filament
 - b. Shape of Filament
 - c. Sizing
 - d. Carbon, Glass, Kevlar
6. PROCESS - SOLUTION, HOT-MELT, POWDER, PULTRUSION

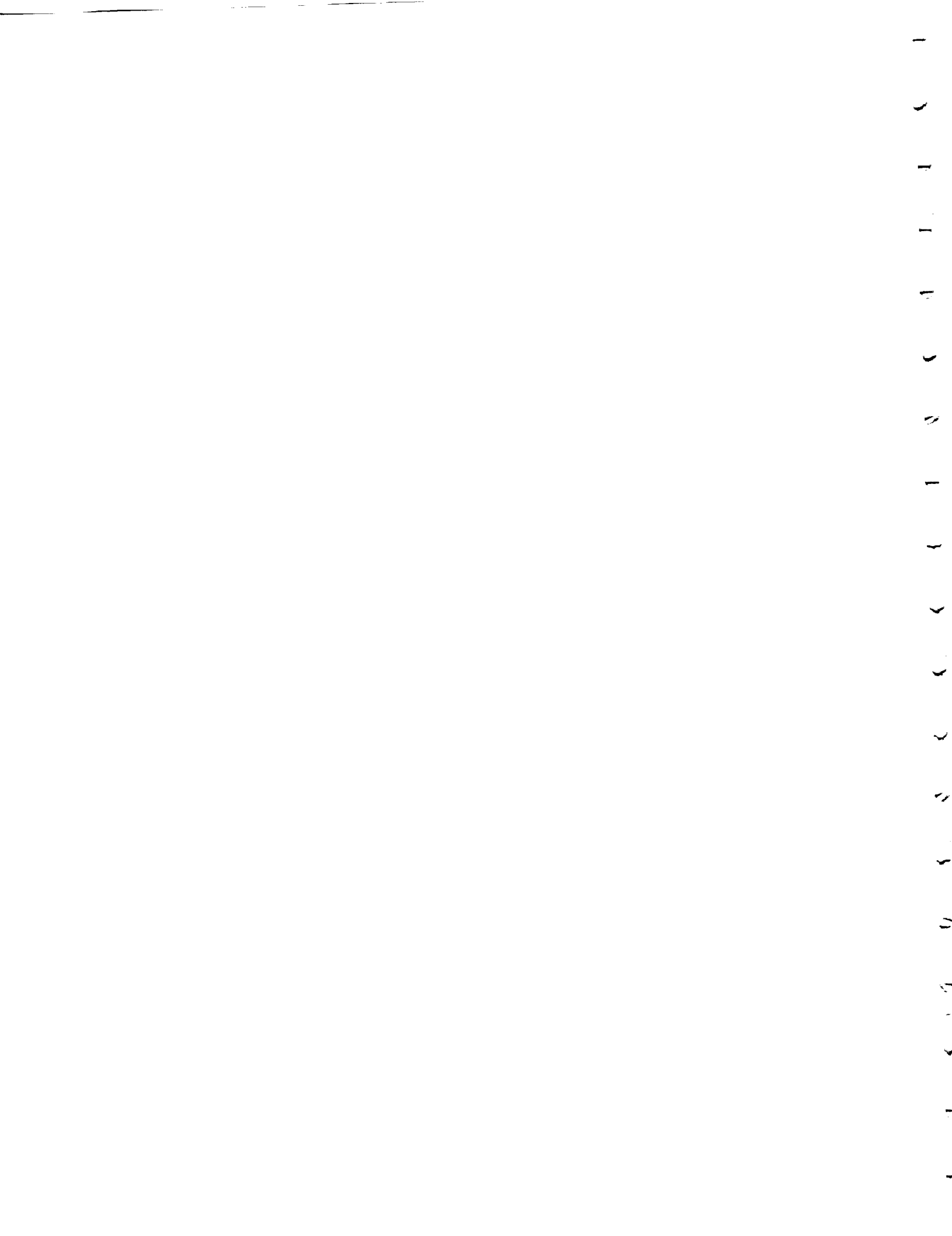

- CHEMIST MUST WORK WITH ITEM #1 AND 6
 - PROCESS ENGINEER CAN ALTER #1, 2, 3, 4, 6
- A. NO LIMITATIONS TO TEMPERATURE OR INDUCTION TIME
1. INDUCTION TIME INCREASED WITH ROLL DIAMETER, NUMBER OF ROLLS, LENGTH OF OVEN AND DIP PANS, DECREASE IN LINE SPEED
- B. PRESSURE MUCH MORE DIFFICULT TO OBTAIN.
1. NIP ROLLS NOT EFFECTIVE FOR IMPREGNATION
 - a. SURFACE RESIN TENDS TO FLOW Laterally rather than through the thickness which causes fiber wash-out and fiber damage.
 2. SOLUTION COATING, POWDER, AND PULTRUSION METHODS ARE MORE EFFECTIVE FOR IMPREGNATION HIGH VISCOSITY MATERIALS.

1
2
3
4
5
6
7
8
9
10
11
12
13
14
15
16
17
18
19
20
21
22
23
24
25
26
27
28
29
30
31
32
33
34
35
36
37
38
39
40
41
42
43
44
45
46
47
48
49
50
51
52
53
54
55
56
57
58
59
60
61
62
63
64
65
66
67
68
69
70
71
72
73
74
75
76
77
78
79
80
81
82
83
84
85
86
87
88
89
90
91
92
93
94
95
96
97
98
99
100

DRY POWDER TOWPREG SYSTEMS

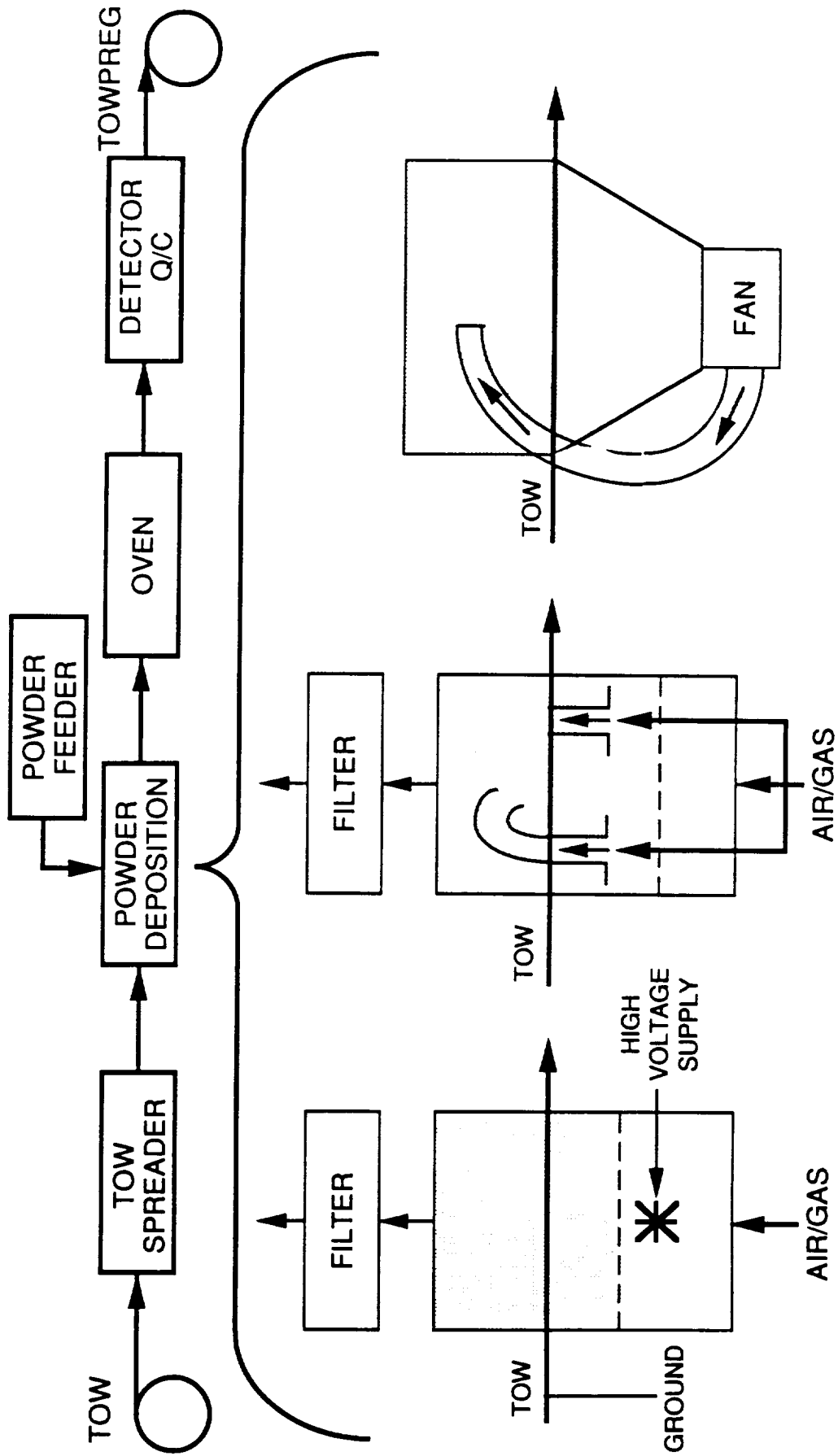

ELECTROSTATIC

FLEXLINE

RECIRCULATING BED



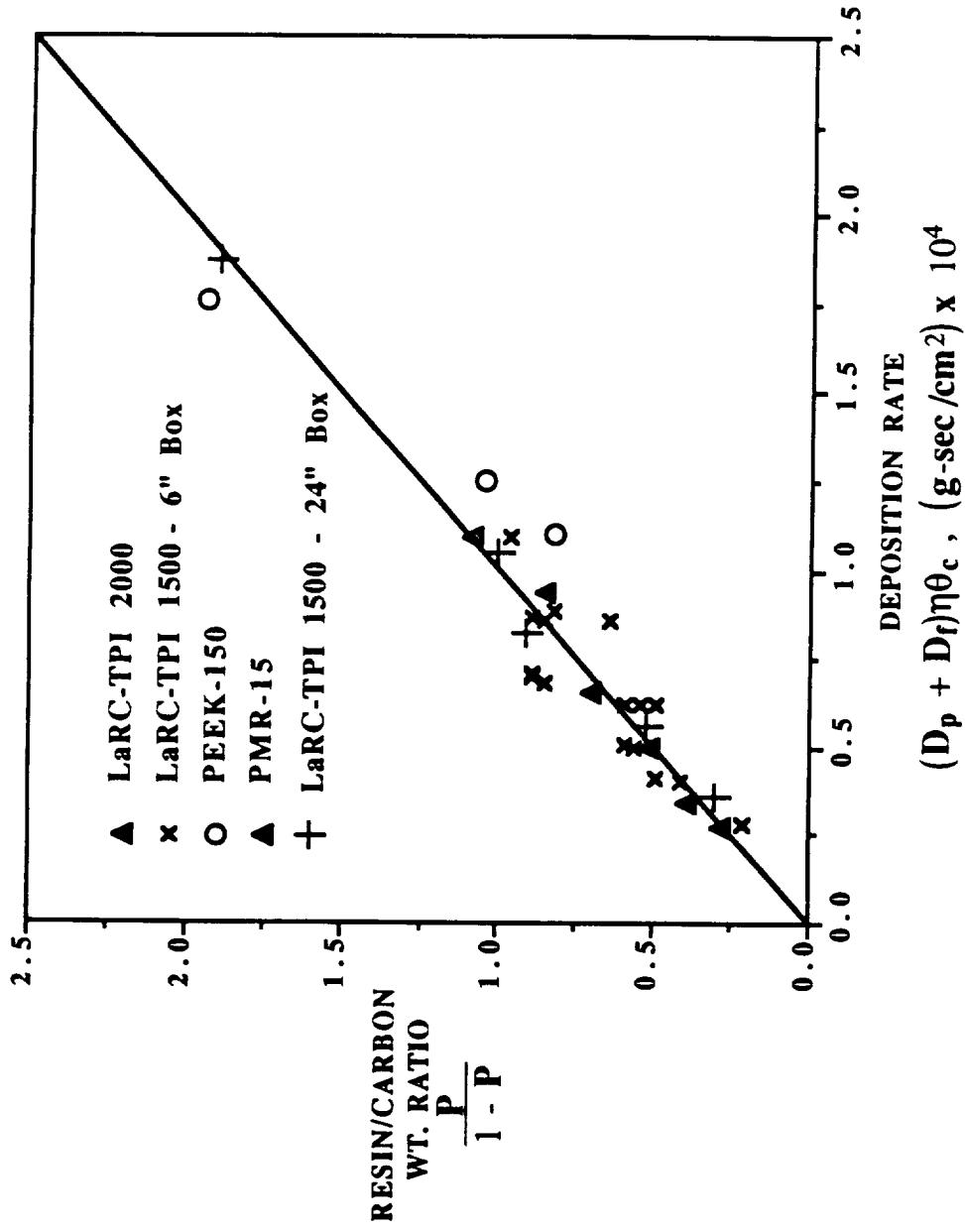
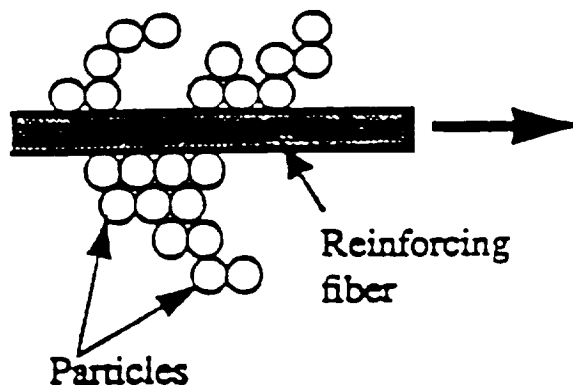

FIGURE 3. POWDER DEPOSITION DATA CORRELATION

1
2
3
4
5
6
7
8
9
10
11
12
13
14
15
16
17
18
19
20
21
22
23
24
25
26
27
28
29
30
31
32
33
34
35
36
37
38
39
40
41
42
43
44
45
46
47
48
49
50
51
52
53
54
55
56
57
58
59
60
61
62
63
64
65
66
67
68
69
70
71
72
73
74
75
76
77
78
79
80
81
82
83
84
85
86
87
88
89
90
91
92
93
94
95
96
97
98
99
100

Heat transfer to the impregnated tow



Interparticle sintering

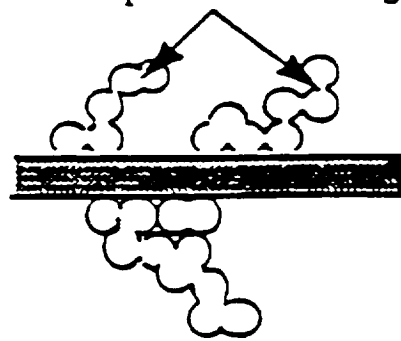

Film coalesces

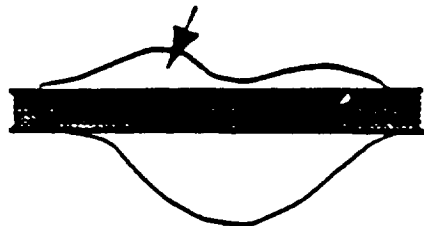

Polymer film

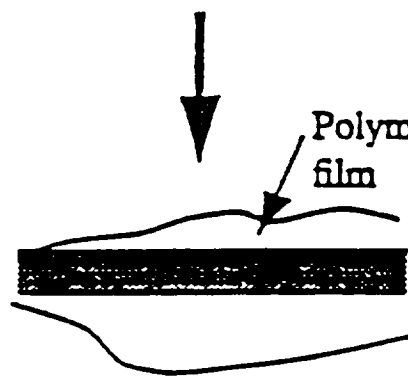

Uniform droplets

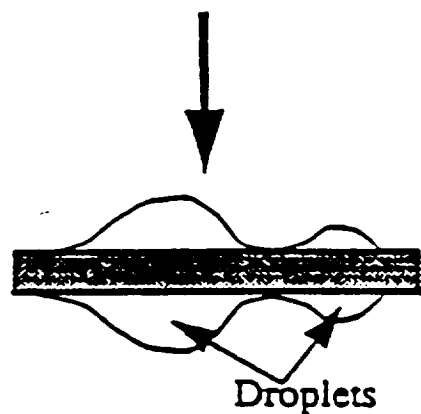

Polymer sheath

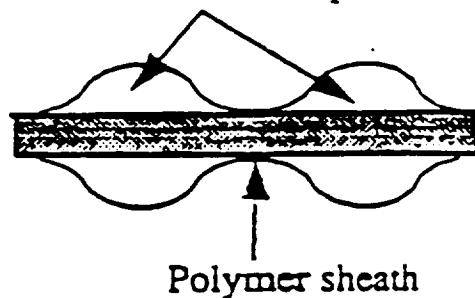

Coalescence in the heater.

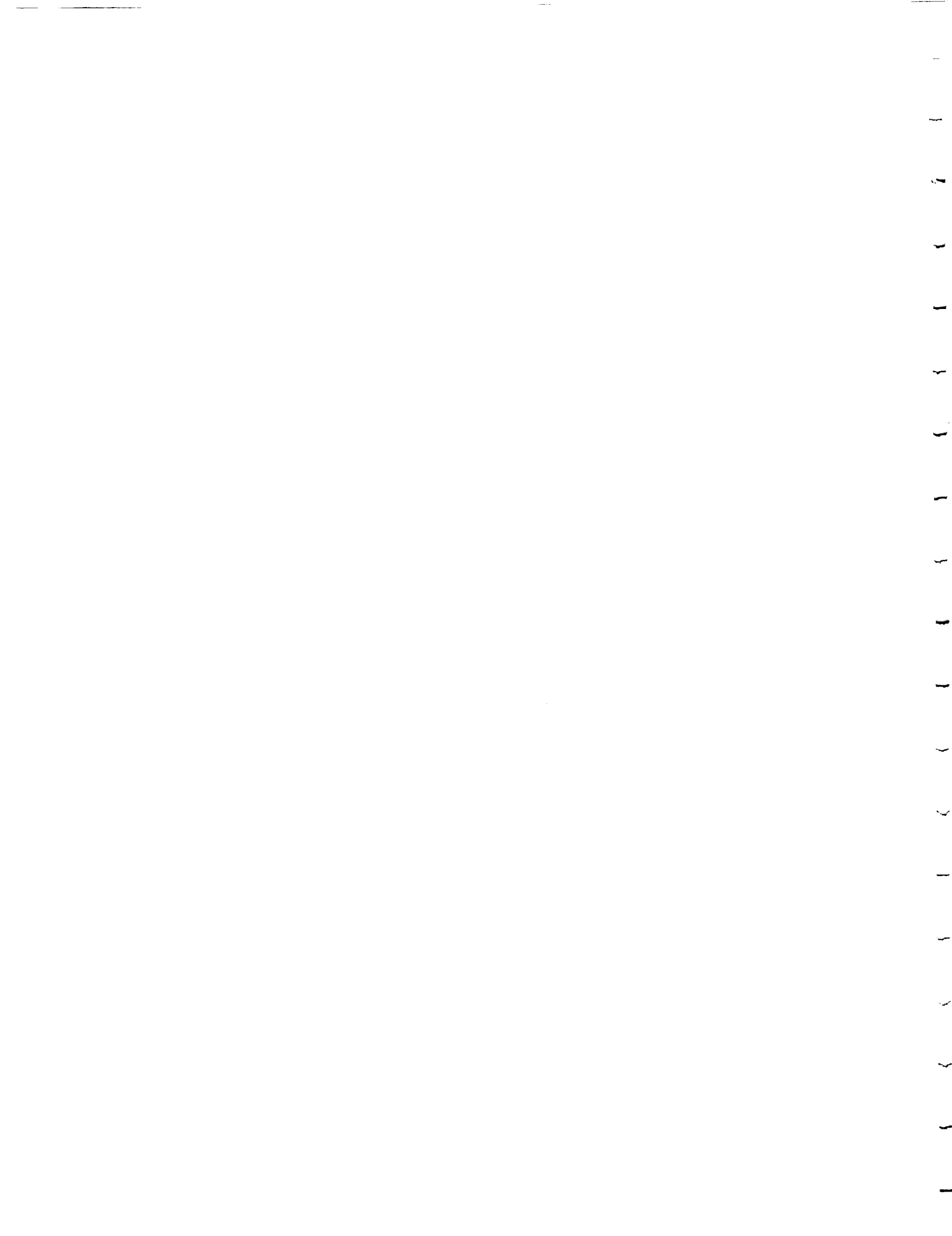

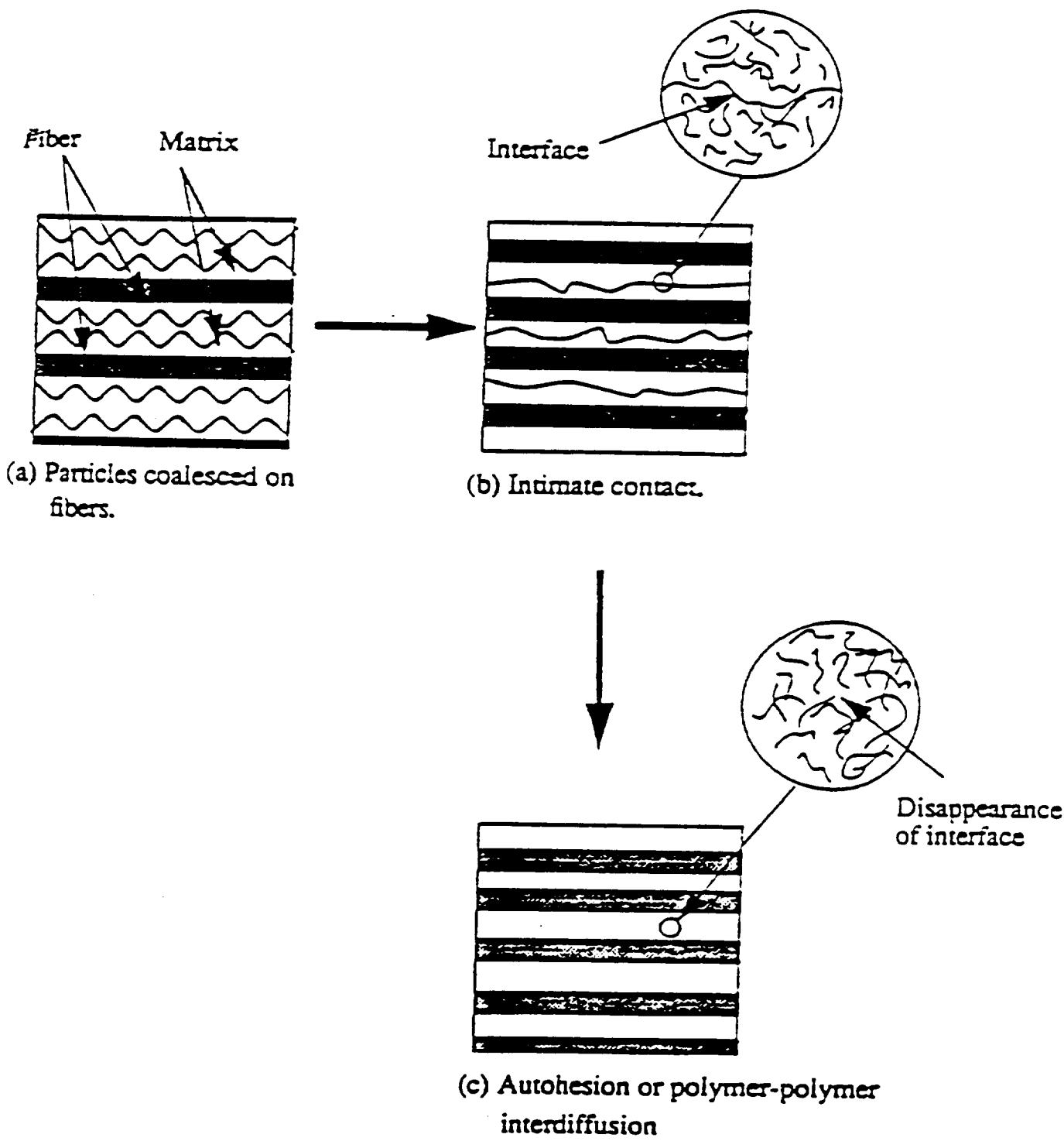

Consolidation of powder-impregnated thermoplastic composite.

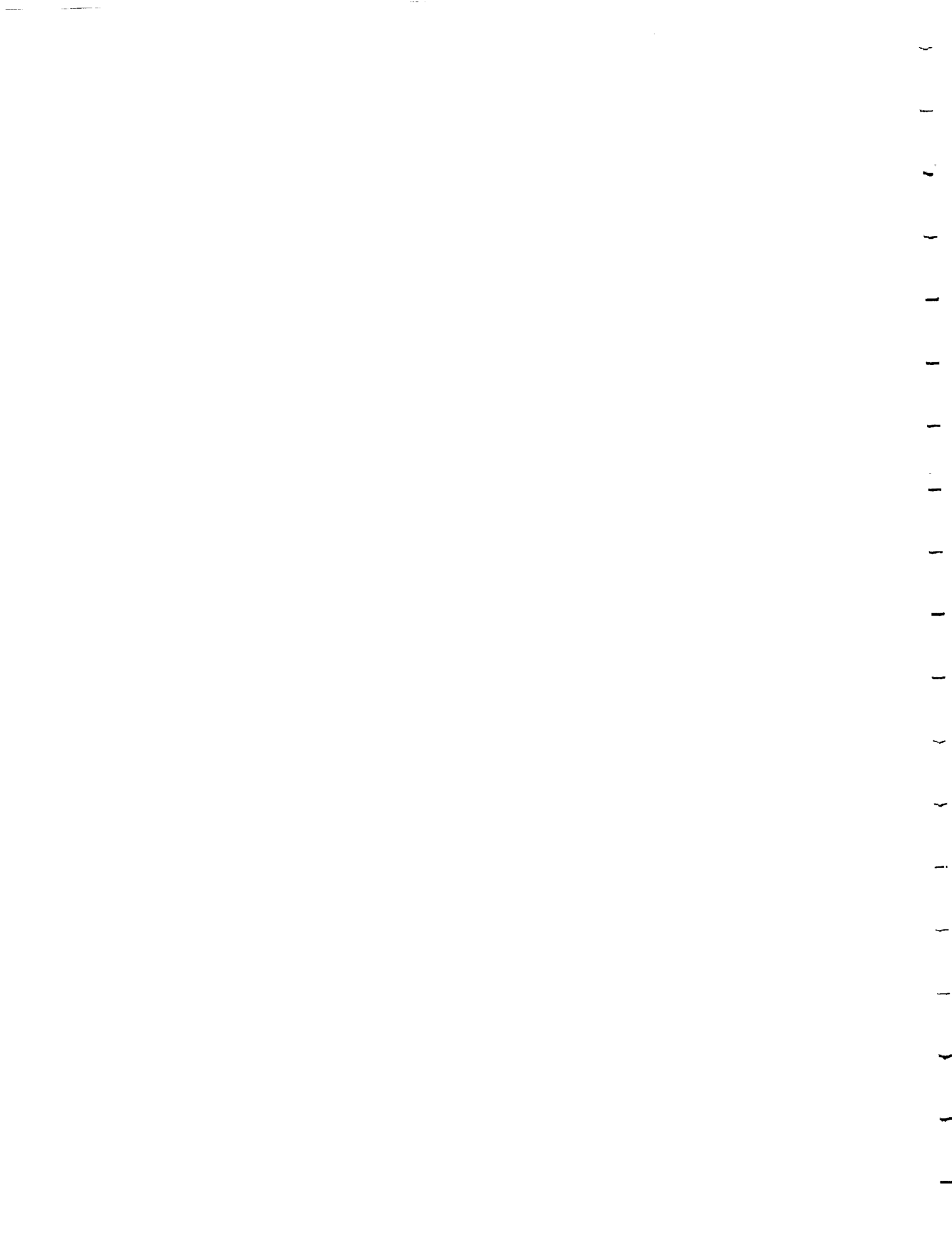

TRANSVERSE FLEXURAL STRENGTH

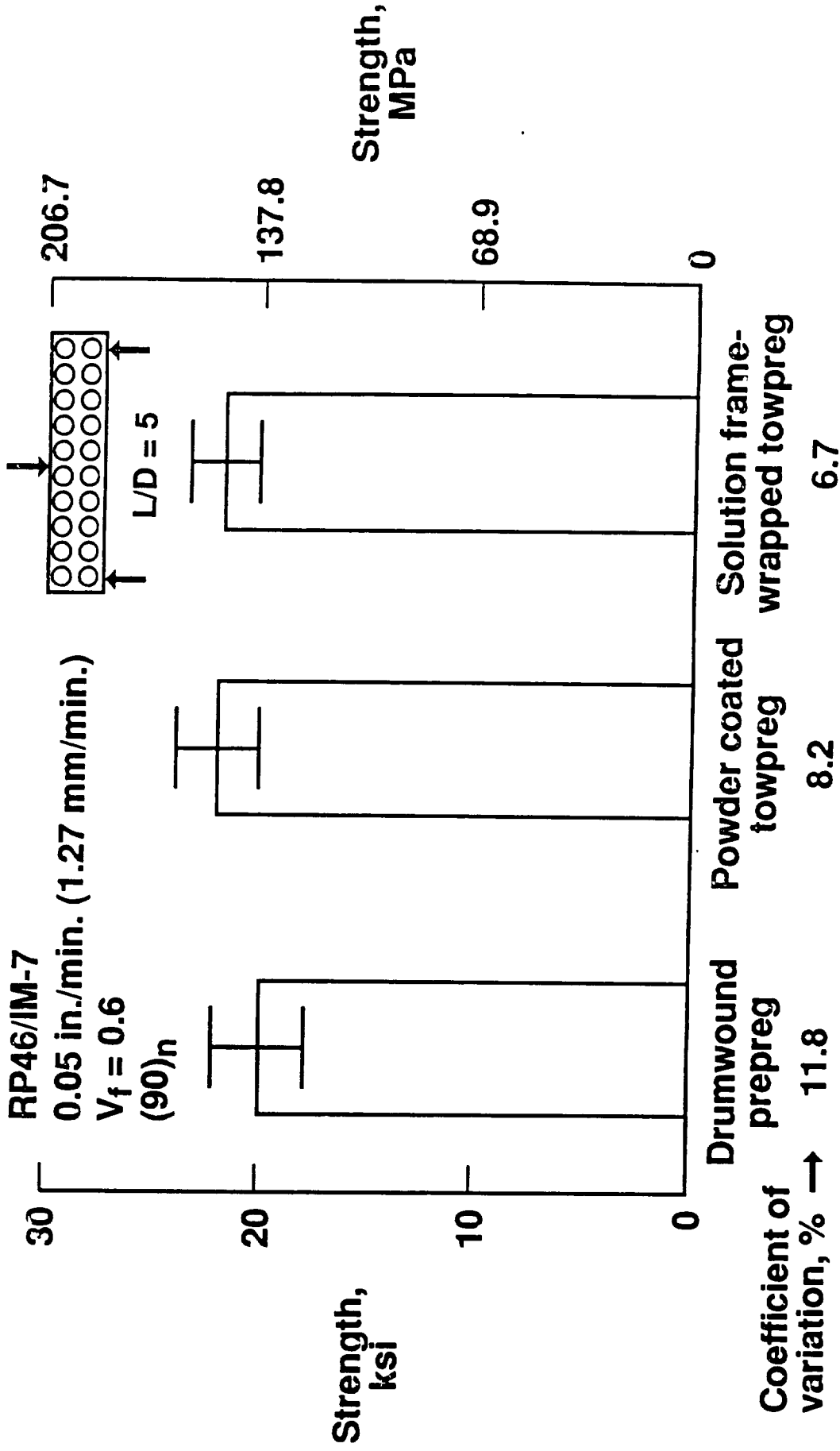

ELECTROPOLYMERIZATION

- Polymerization coating at an electrode surface in an electrochemical cell.
- Conductive fibers, such as graphite, serve as the electrode.
- Polymer systems include: Maleimides, Acrylamide derivatives, and polyphenylene oxide (free radical polymerization).
- Solvents include: Dimethoxyethyl ether (diglyme), cellosolve/carbitol glycol ethers, acetic acid.
- Rate is proportional to current density and monomer concentration.
- Laboratory data indicate a 30% improvement in impact strength and a 15% improvement in interlaminar shear strength.

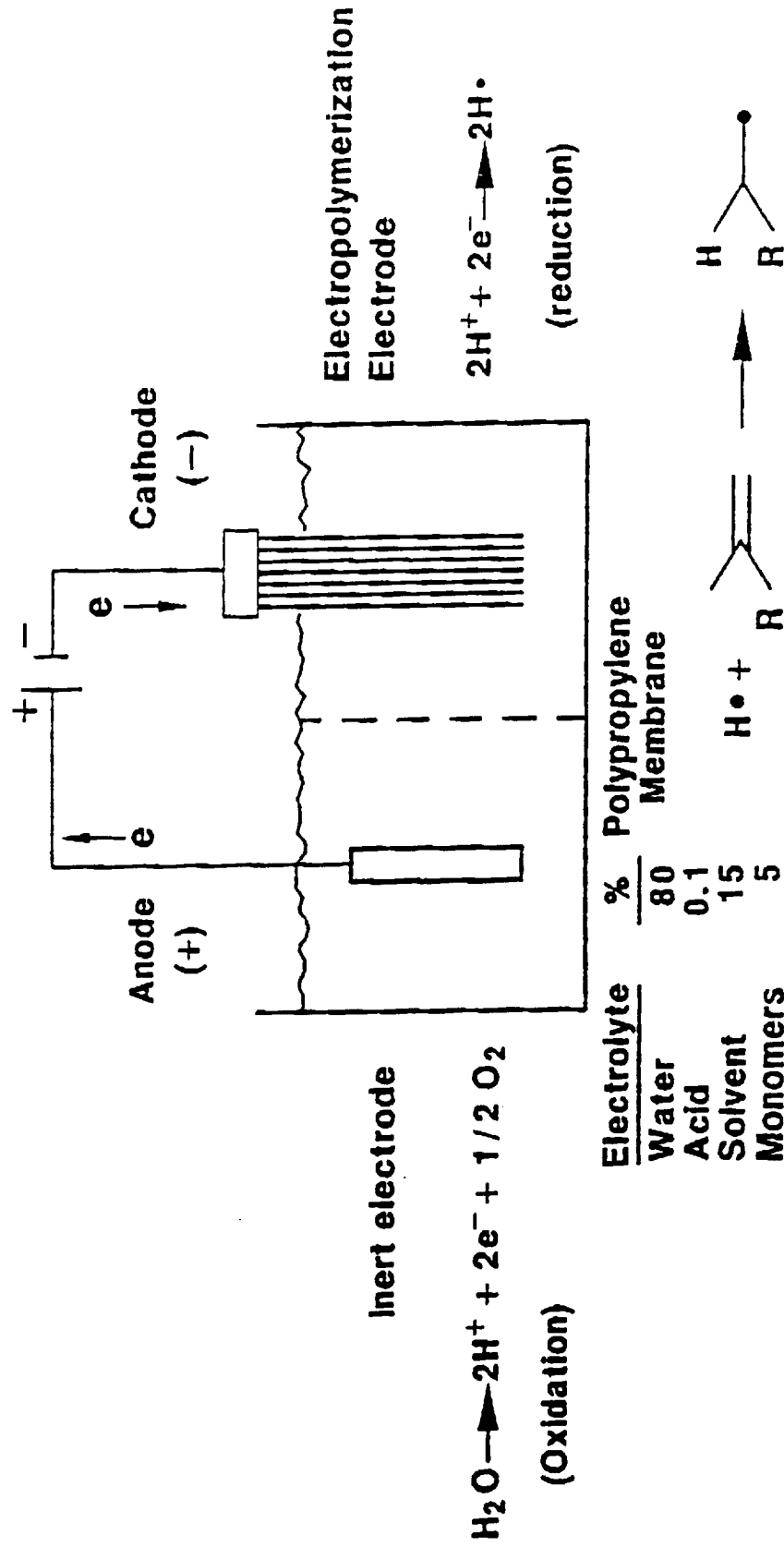

Electropolymerization of Resins Directly onto Graphite Yarn

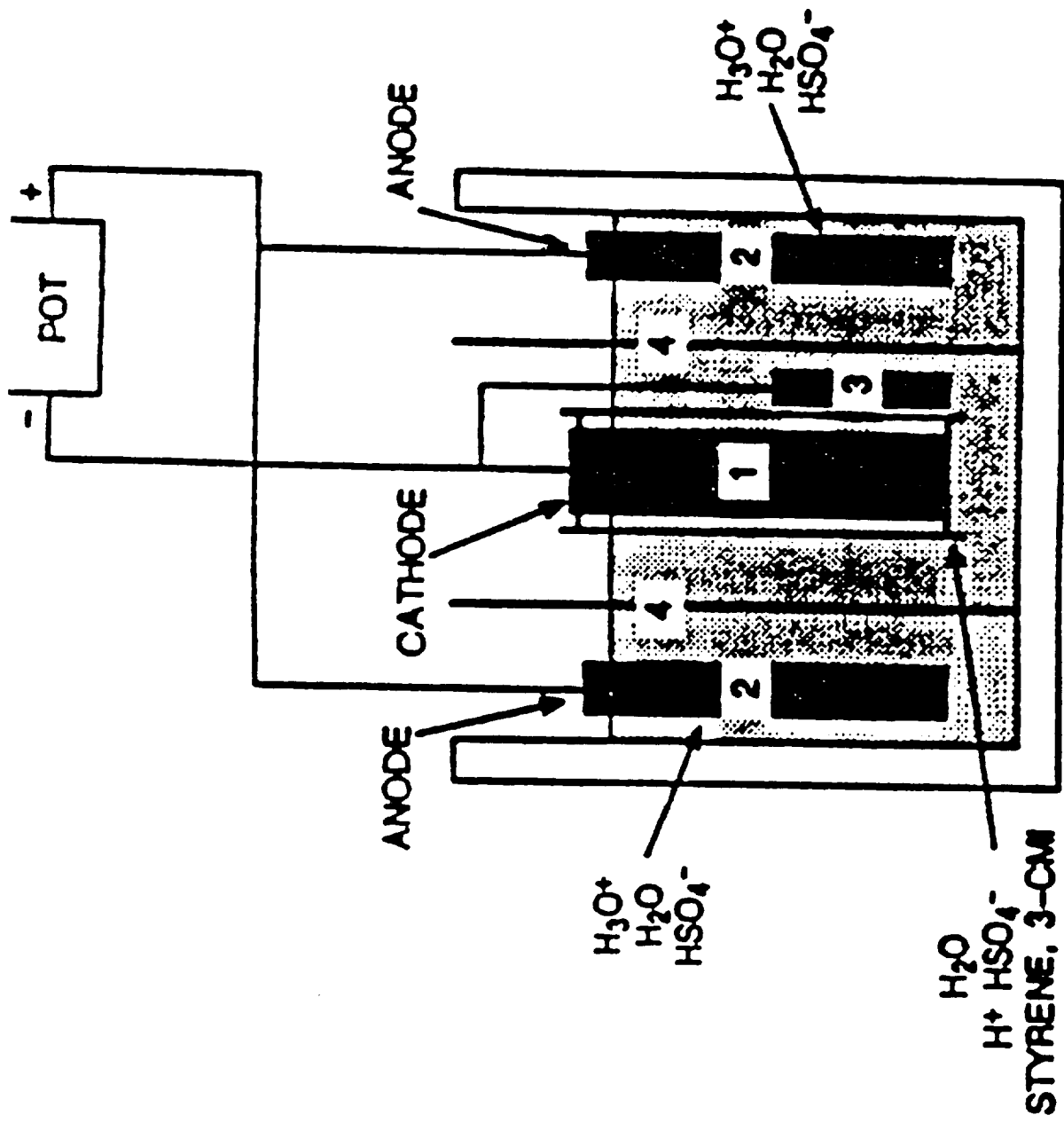

Schematic Representation of the Electropolymerization Cell Showing:

- (1) Working Electrode - Graphite Fibers, (2) Counter Electrodes - Stainless Steel, (3) SCE Reference Electrode, (4) Polypropylene Membrane

VAPOR PHASE POLYMERIZATION/DEPOSITION

- Monomers vaporized and deposited, with polymerization on fibers.
- Systems include:
 - Pyrene films on metal-insulator-semiconductor junctions
 - Polyamide (4-4'-oxyaniline and (1, 2, 4, 5 benzenetetracarboxylic anlyride) on silver

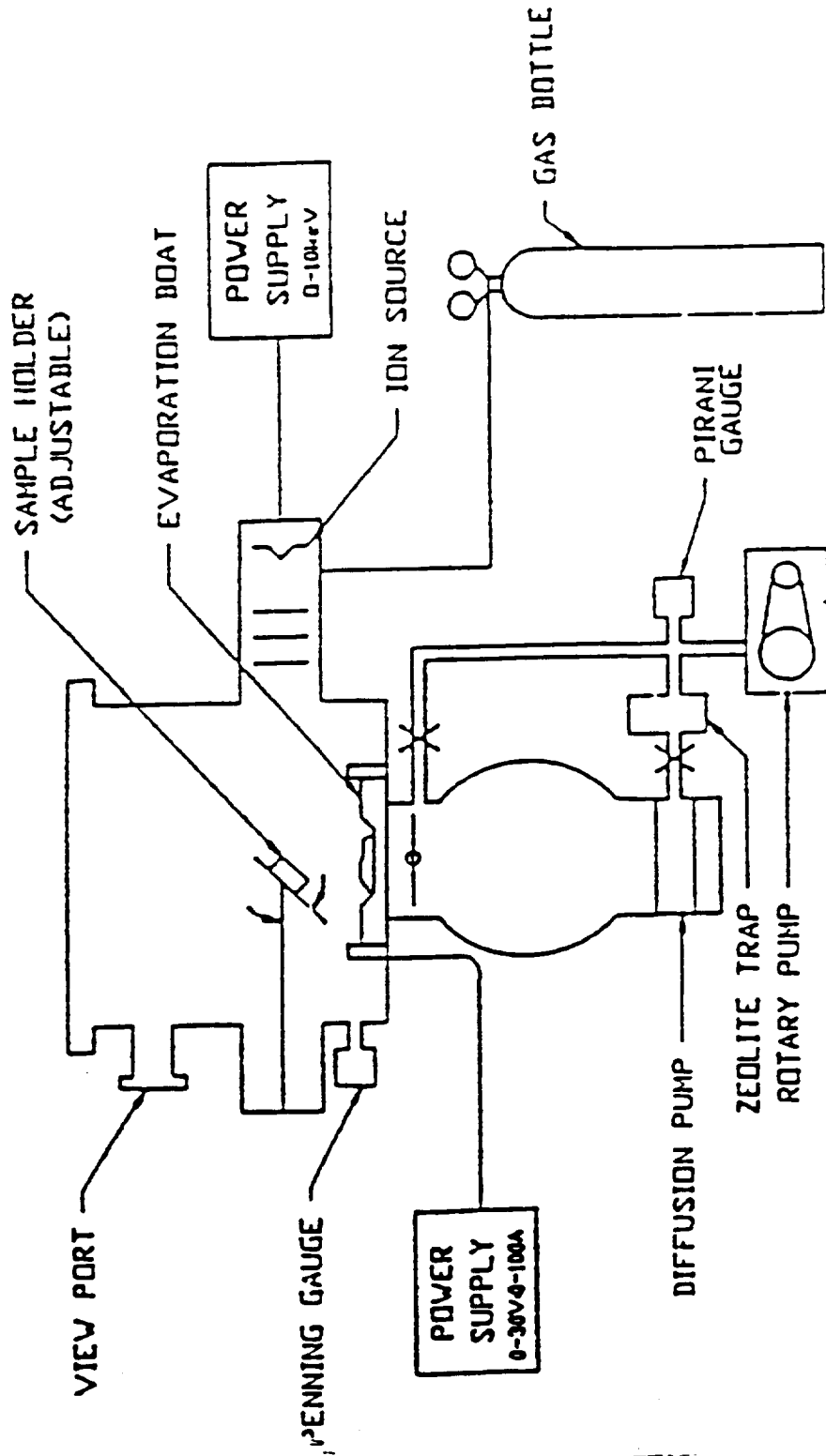
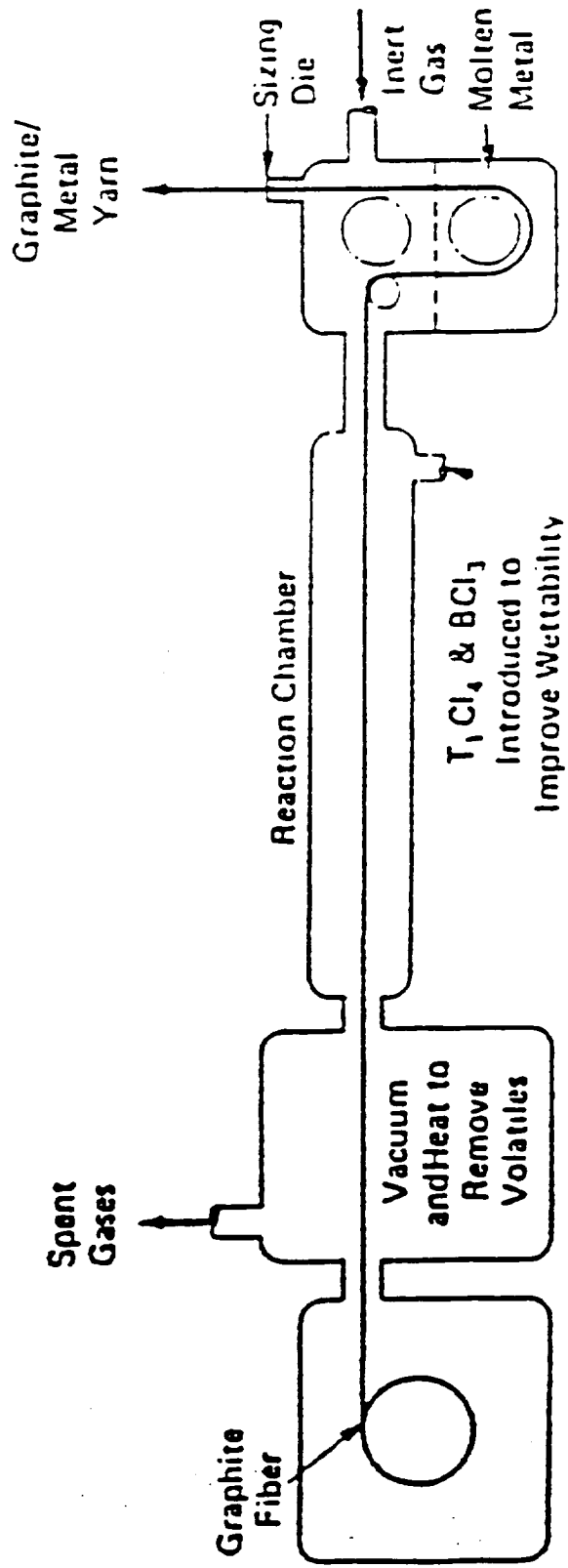
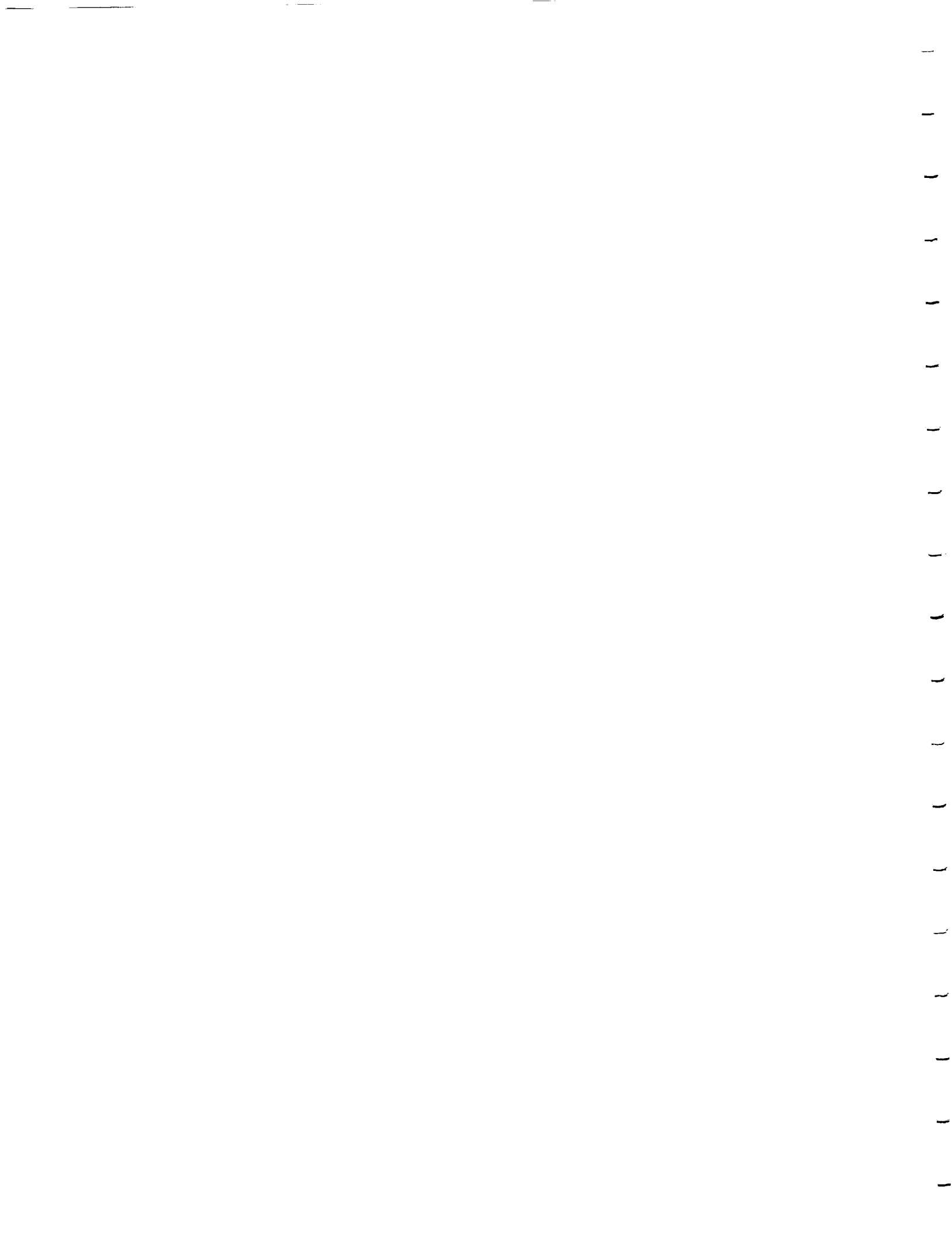

Diagram of the Apparatus Used for the Ion Beam Assisted Deposition and Crystallization of Thin Films of Pyrene.



Schematic Process of Graphite Fiber Tow Impregnated with Metal



Prepregging often involves

PRECONSOLIDATION

of the resin - fiber assembly

Preconsolidation required:

- unitape
- fabric
- ribbon

Preconsolidation not required:

- commingled tow
- powder coated tow

PRECONSOLIDATION

RESIN FLOW

WETTING

VOIDS

WEB ELASTICITY

THERMOSET CURE

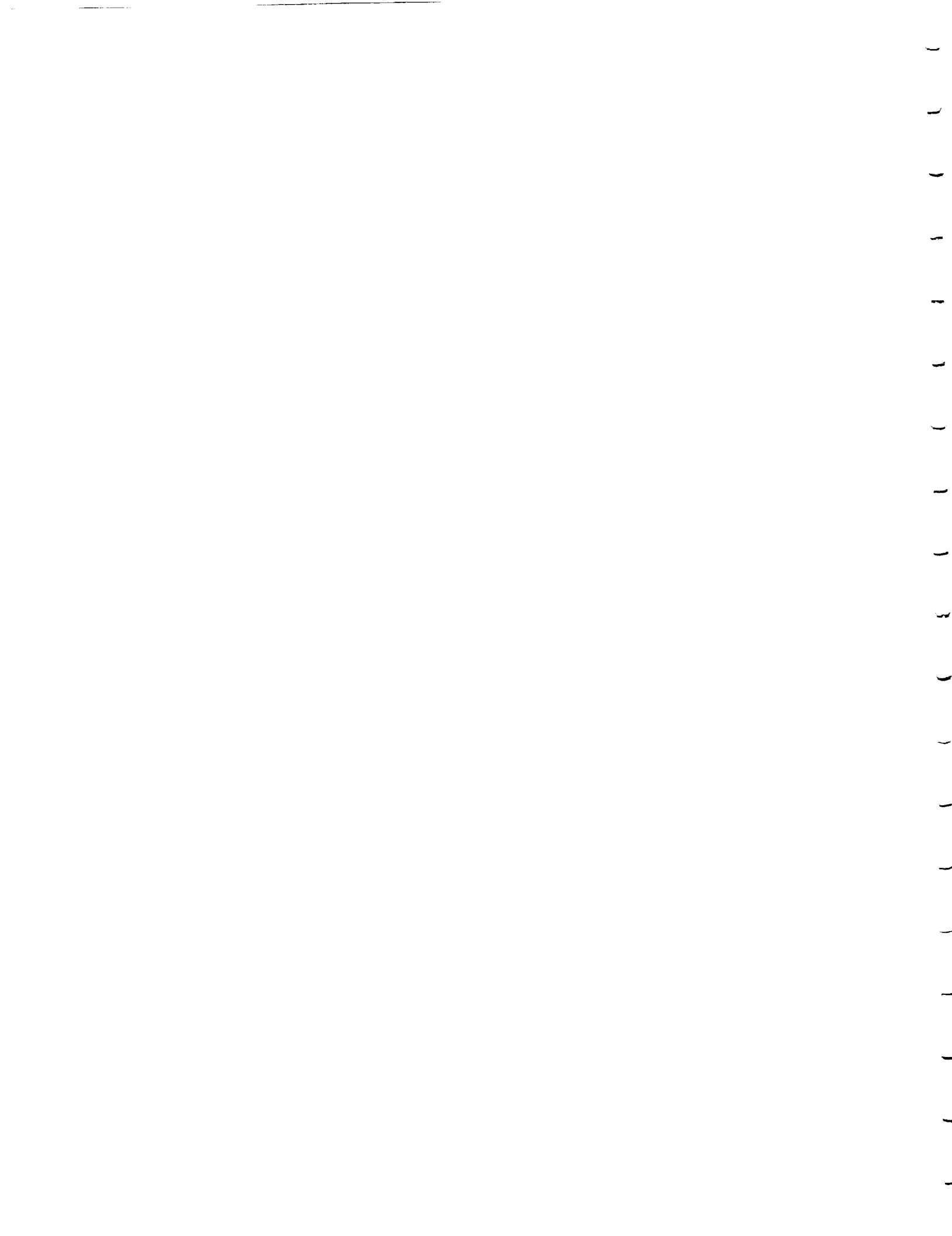

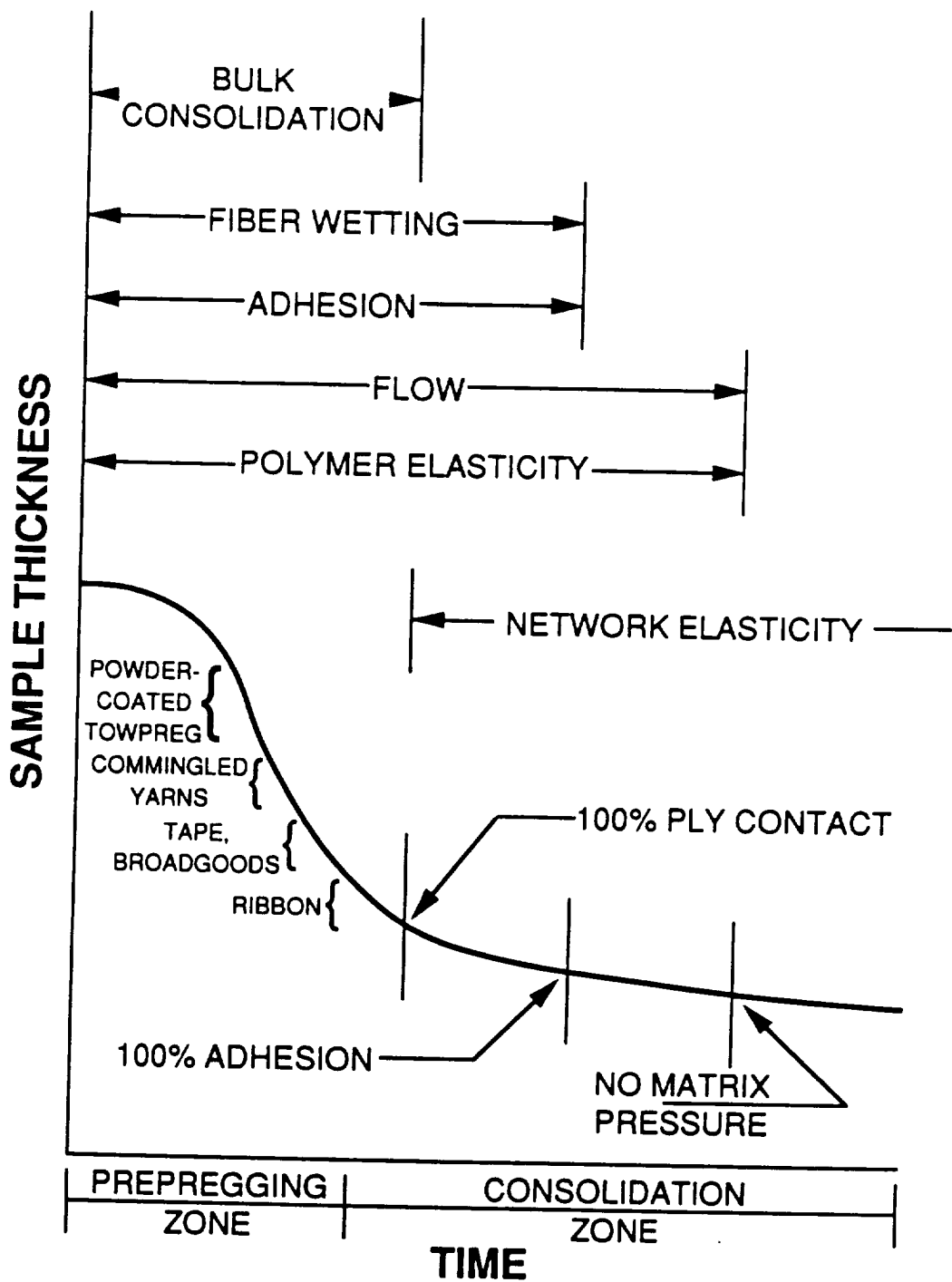

VARIATION IN COMPOSITE THICKNESS DURING CONSOLIDATION

PRECONSOLIDATION MECHANISMS

Bulk (Initial) Consolidation - Depends on rate of pressure application, fiber wetting and resin flow.

Fiber Wetting - Surface Tension and Long Range Van der Waals forces; Time requirement: fraction of a second for high flow, several seconds for low flow resins.

Resin Flow - Viscosity and pressure; Time requirement: capillary penetration times are several seconds (5 sec) for low flow (1,000 poise) resins.

Autohesion - Contact area and diffusion; interface adhesion times are of the order of seconds.

Network Stress Relaxation - Release pressure after cooling below T_g .

Polymerization (Thermosets) - Exotherm heat removal

Crystallization - Cooling rate is critical between T_m and T_g : quench for amorphous, slow cool for large grain sizes.

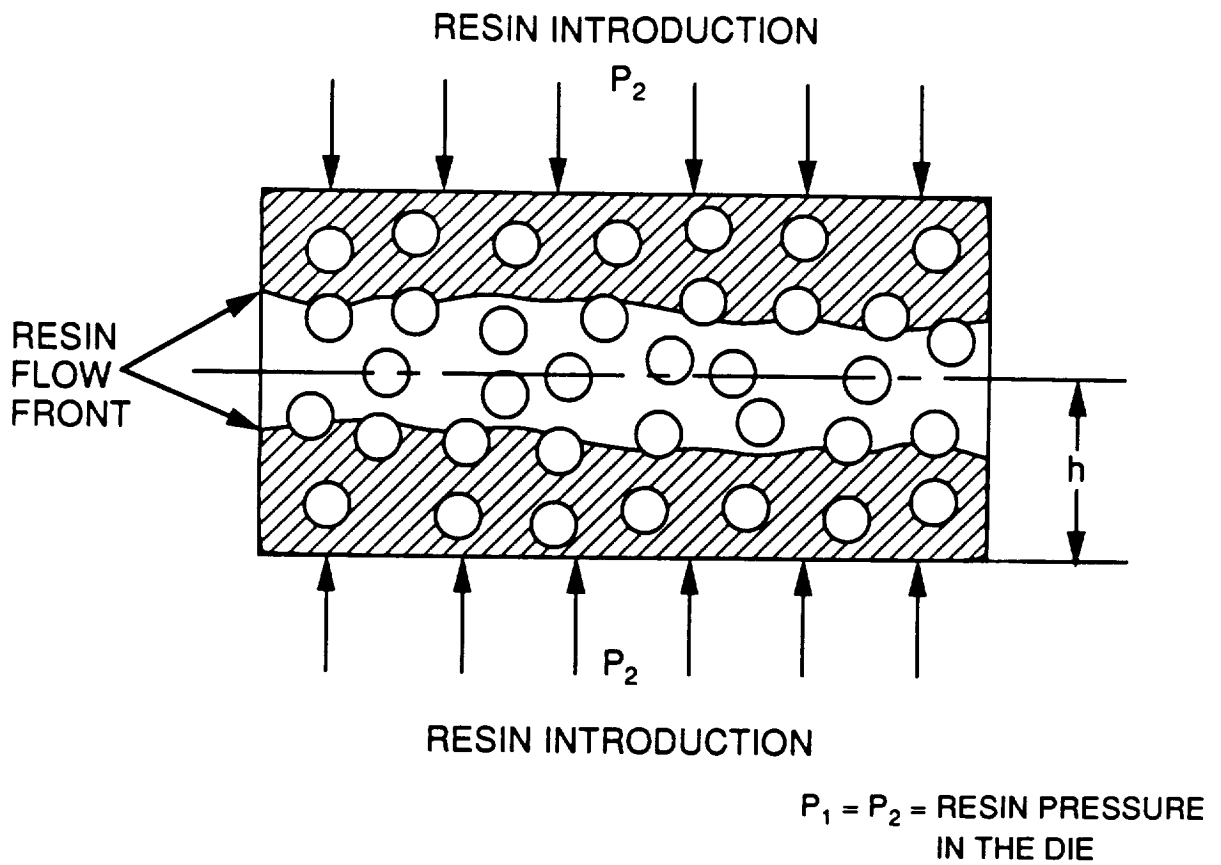

Through The Thickness Impregnation Model

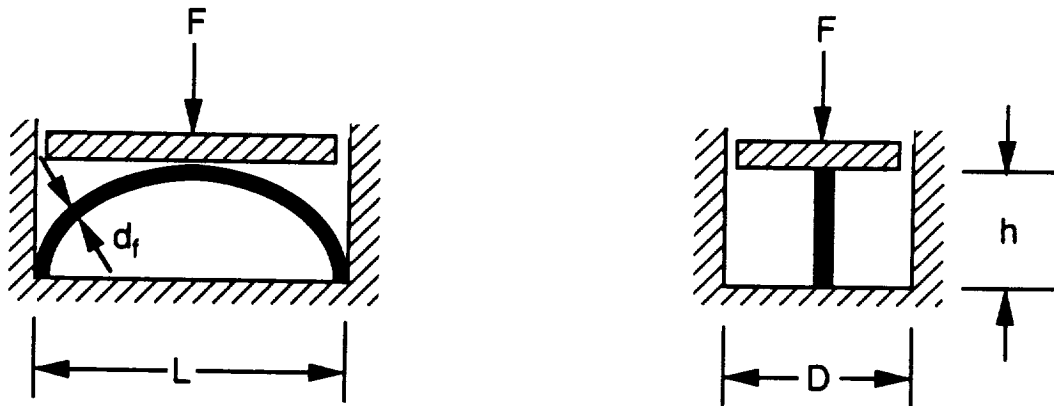

Geometry for a Unit Bending Cell Used to Derive the Stiffness of a Bundle. Note that the Parameter $\beta = L/(h-d_f)$

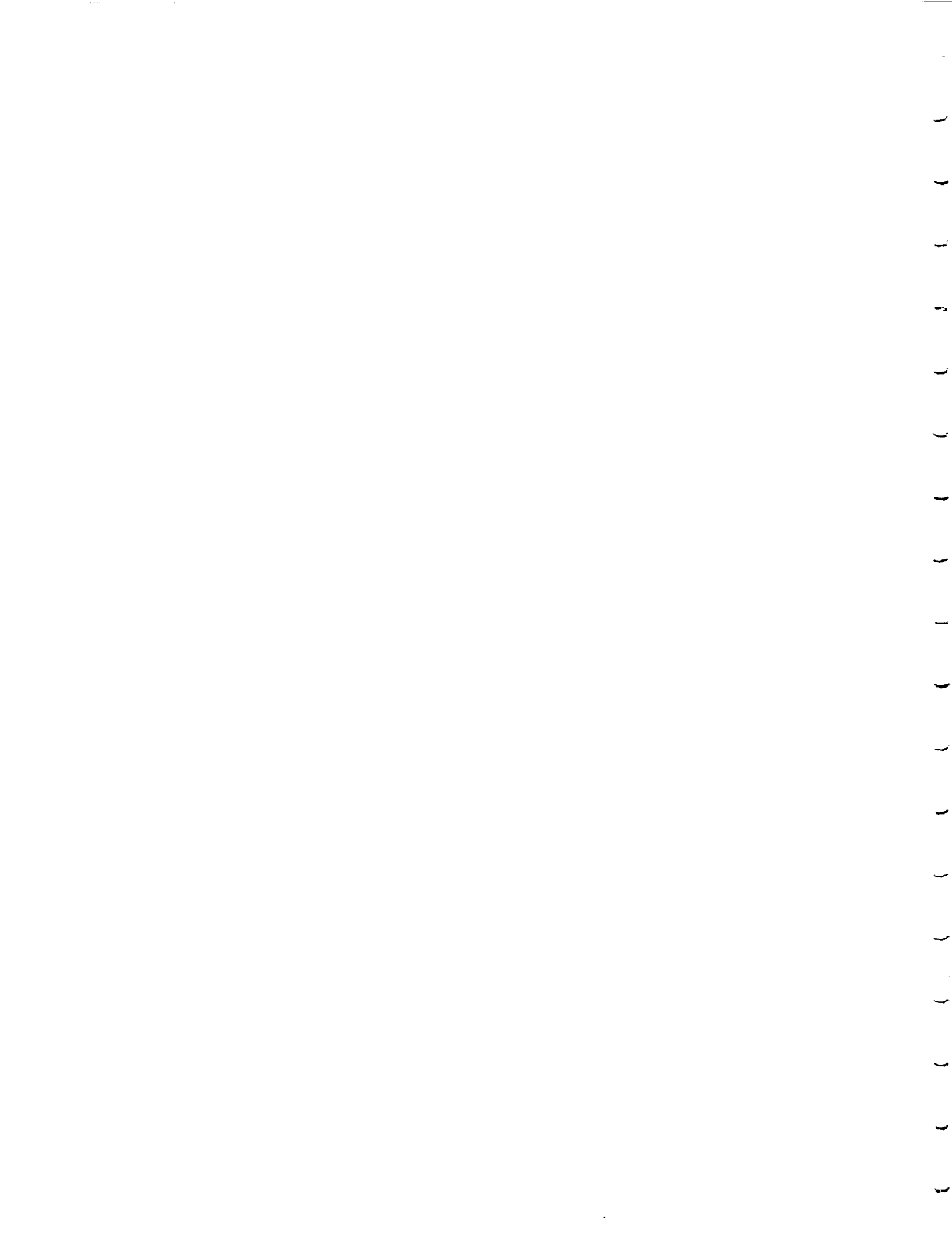

IMPREGNATION FLOW MODEL

Resin flow through a porous media, Darcy's Law

$$q = \frac{-S}{\mu} \frac{dp}{dx}$$

S is the permeability of the fiber bundle and μ is the Newtonian viscosity. Carman-Kozeny equation for S.

$$S = \frac{r_f^2}{4k} \frac{(1 - V_f)^3}{V_f^2}$$

r_f is the radius of the filament, v_f is the fiber volume, and k is the Kozeny Constant. Deformation of the fiber bundle, Gutowski, assumes that the fibers behave as bending beams between multiple contact points.

$$\sigma = \frac{3\pi E}{\beta^4} \frac{\left(\sqrt{\frac{V_f}{V_0}} - 1 \right)}{\left(\sqrt{\frac{V_m}{V_f}} - 1 \right)^4} = \Delta P$$

σ is the Transverse stiffness, E the fiber bending stiffness, and β the fiber length to height ratio.

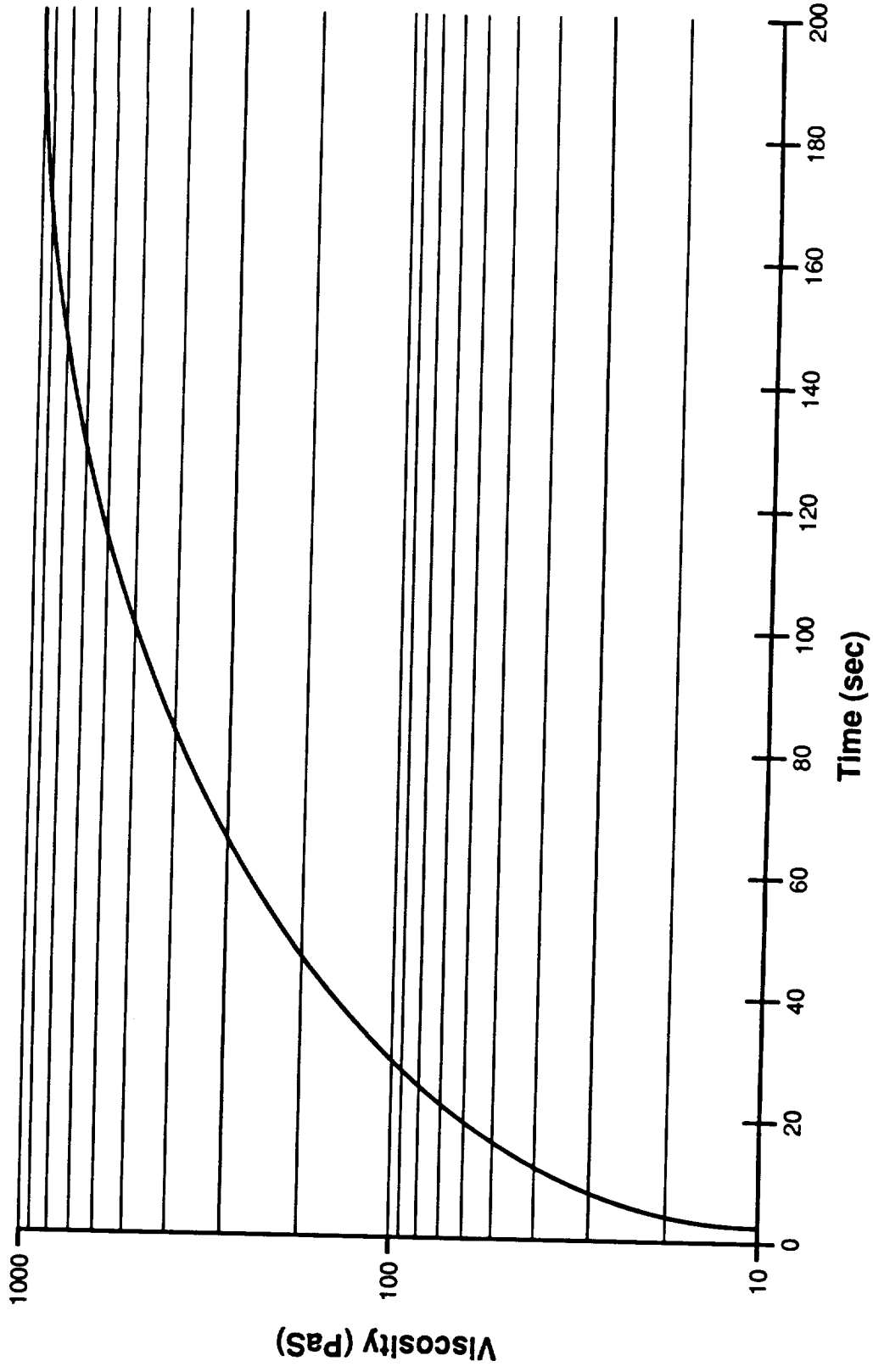

Time Required To Achieve Impregnation



FIBER SIZING

- To promote adhesion of polymer and fibers, tailored sizing may be applied to activated fibers.
- Surface activation entails cleaning, etching and oxidation of fiber to provide accessible, reactive sites for bonding of sizing.
- Sizing is selected to be nonvolatile at processing temperature and compatible with the matrix.
- Sizing often is a low molecular weight uncured polymer that can react with activated fiber surface and with matrix polymer.
- Fiber treatment may be done in-line with fiber formation or during prepreg formation (solution coating).
- Sizings are proprietary formulations

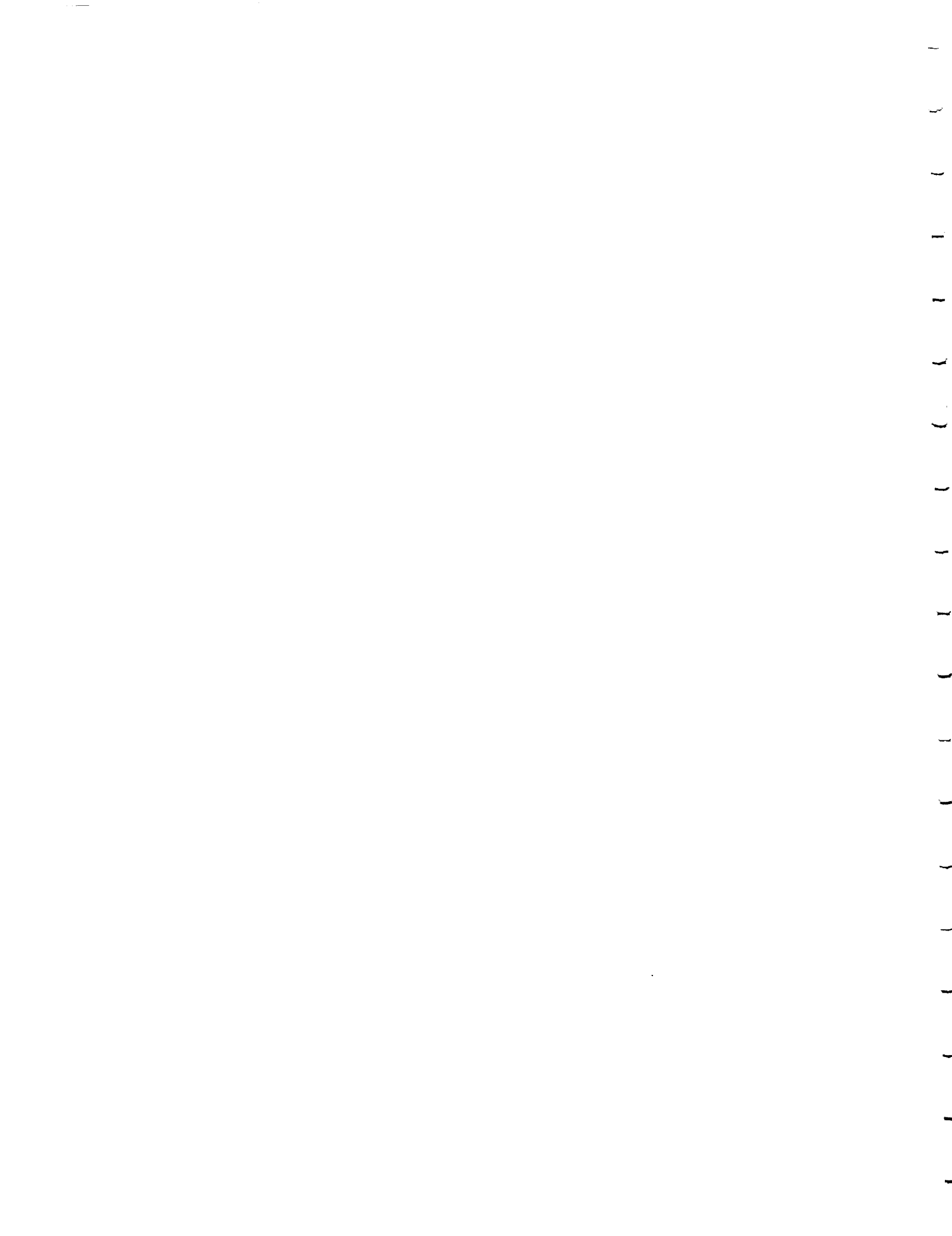

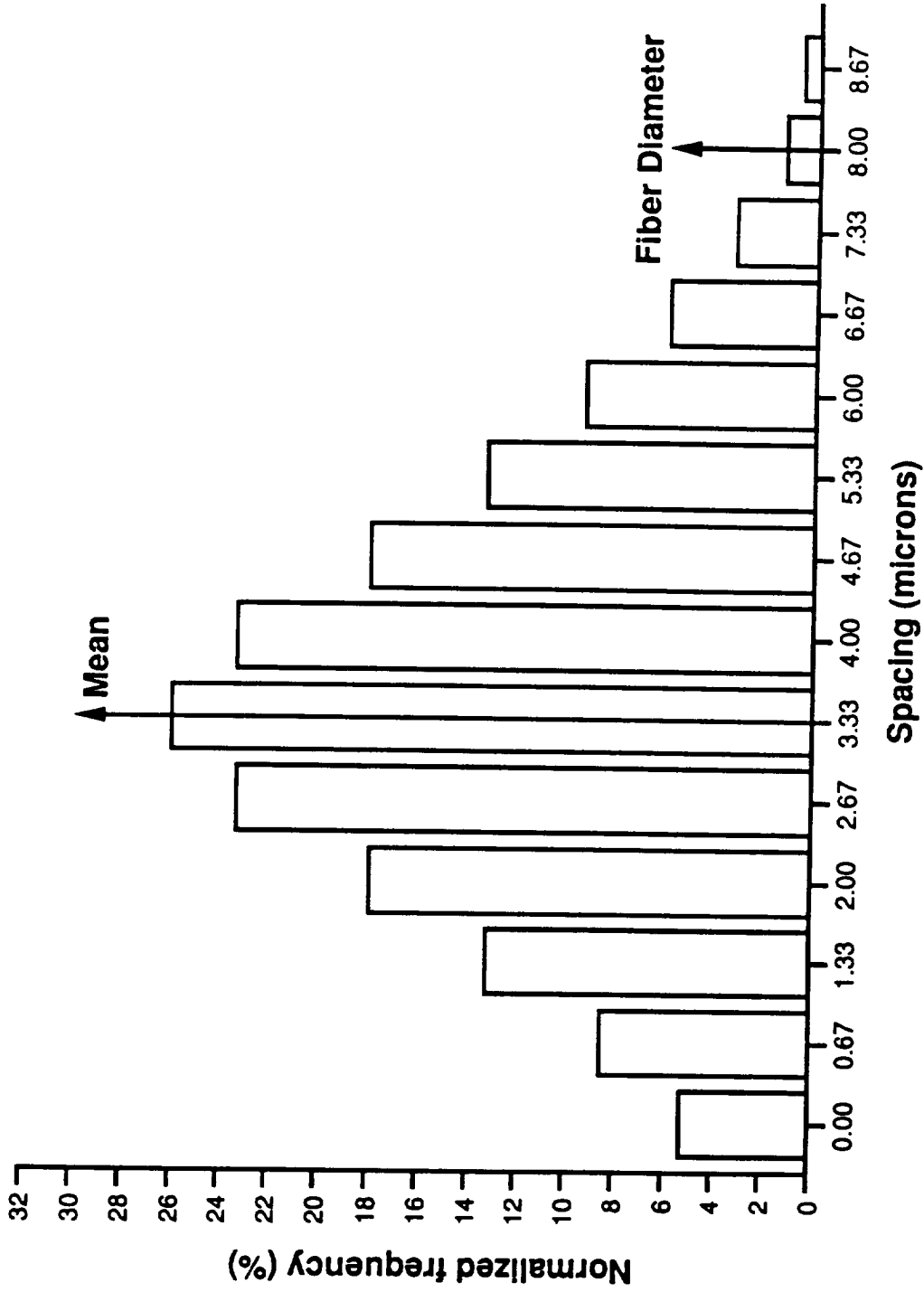

**Normalized Frequency Distribution of Fiber Spacings
in a Preconsolidated Prepreg**



VOIDS IN COMPOSITES

FORMATION - ENTRAPMENT OF AIR AND PRODUCTION OF BUBBLES FROM VOLATILES LEAVING THE RESIN

NUCLEATION - CAUSED BY MOISTURE OR VOLATILES

VOIDS MAY DISAPPEAR DURING PROCESSING AS A RESULT OF RESIN FLOW AND VOID DIFFUSION IN THE FIBER DIRECTION.

A VOID MUST NUCLEATE TO A CRITICAL SIZE BEFORE IT BECOMES STABLE.

GROWTH OCCURS BY AIR OR MOISTURE DIFFUSION OR BY AGGLOMERATION OF VOIDS.

FOR GROWTH THE VOID PRESSURE MUST BE LARGER THAN THE SUM OF THE RESIN HYDROSTATIC PRESSURE AND SURFACE TENSION FORCES.

DISSOLUTION MAY OCCUR DUE TO DECREASED TEMPERATURE OR INCREASED PRESSURE.

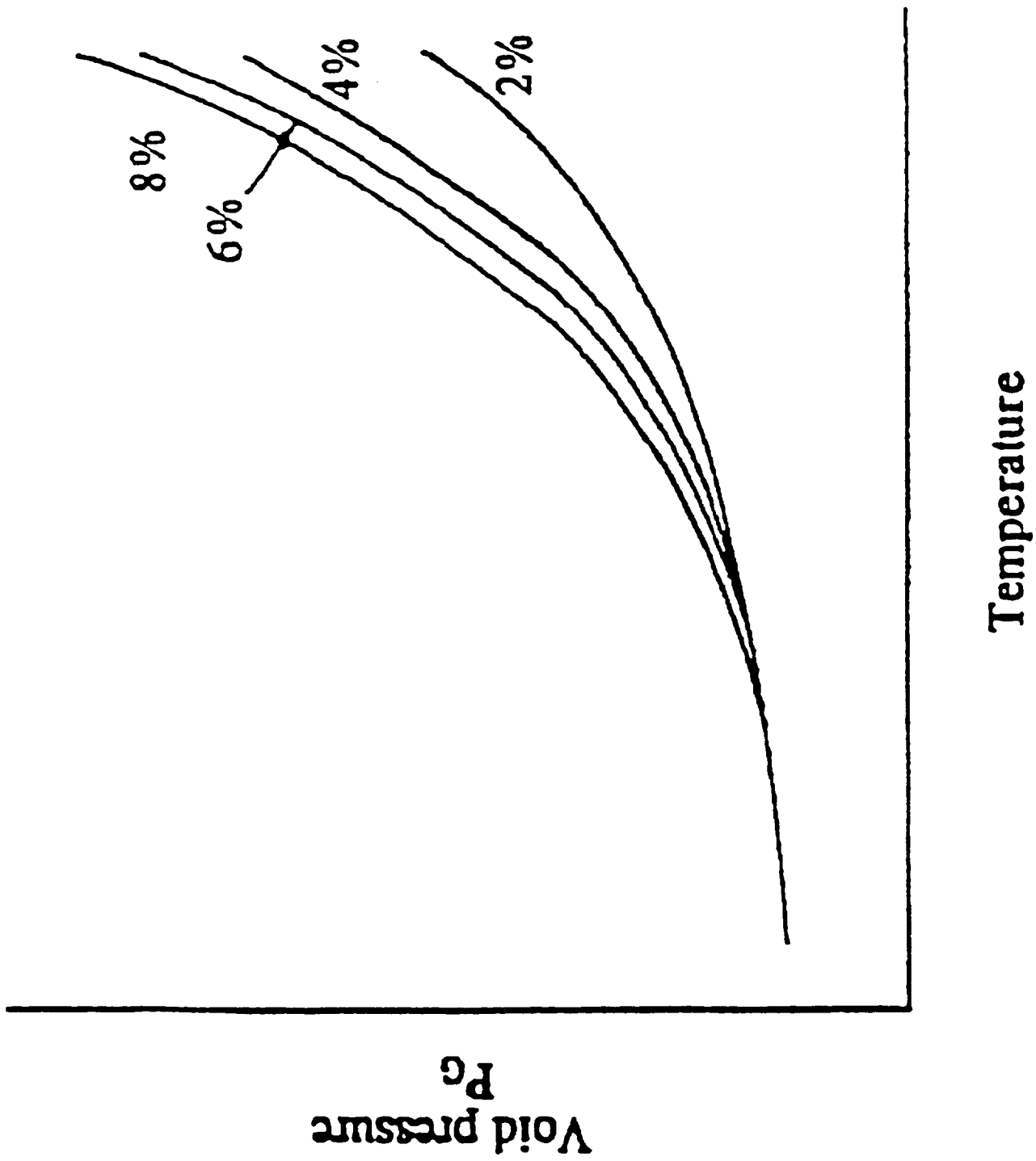

Void Pressure Versus Temperature for Different Moisture Contents in the Resin.



Conditions of Growth

- 1) Initial Pure Water Void Diameter = 0.1 cm
- 2) Initial Humidity Exposure = 75%
- 3) Hold-Up Time during Stage 2 = 90 min.
- 4) Autoclave Pressure of 5.78 Atm applied during Stages 3 to 5

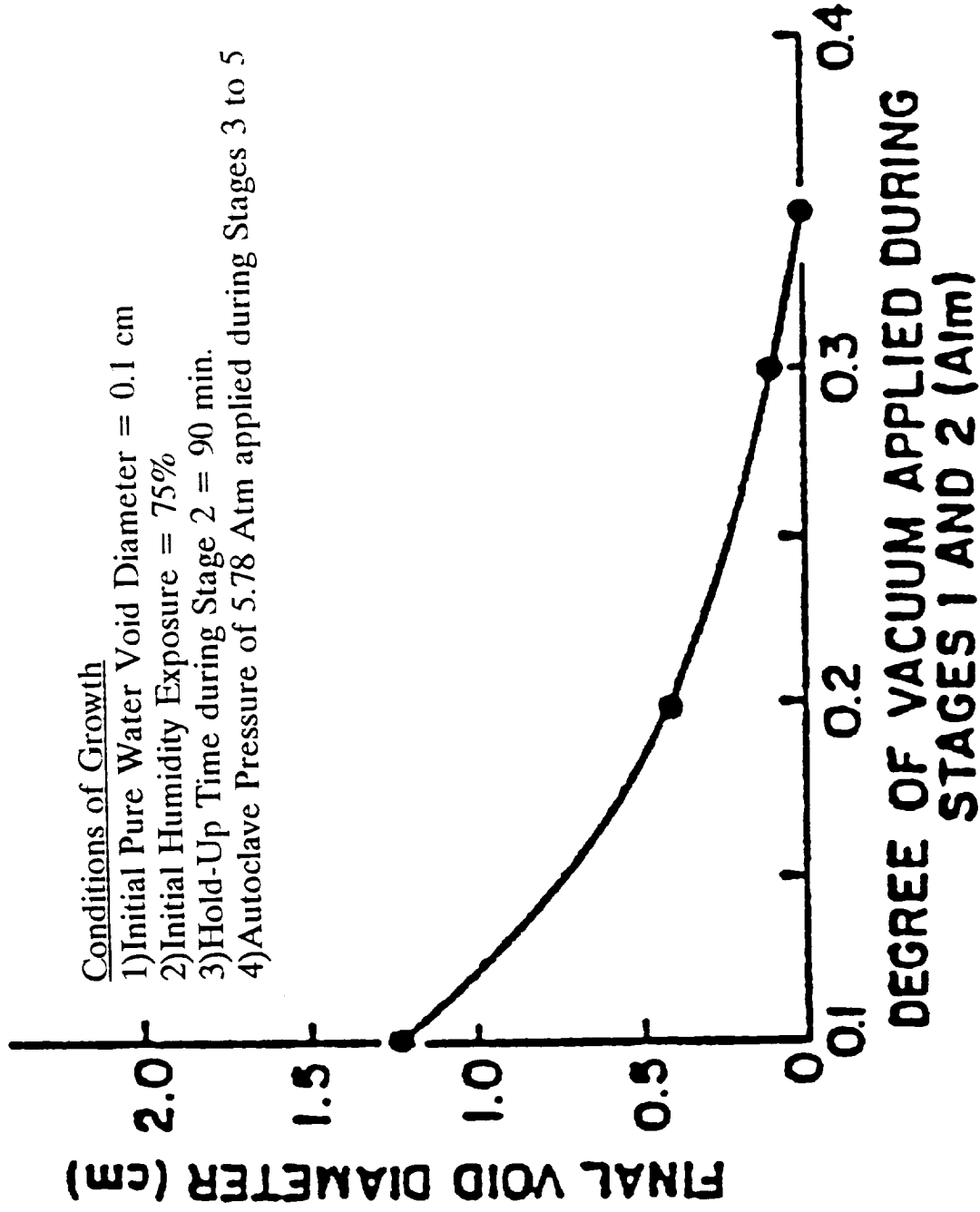

Effect of low matrix pressure (degree of vacuum) on the final void size for the process conditions shown.

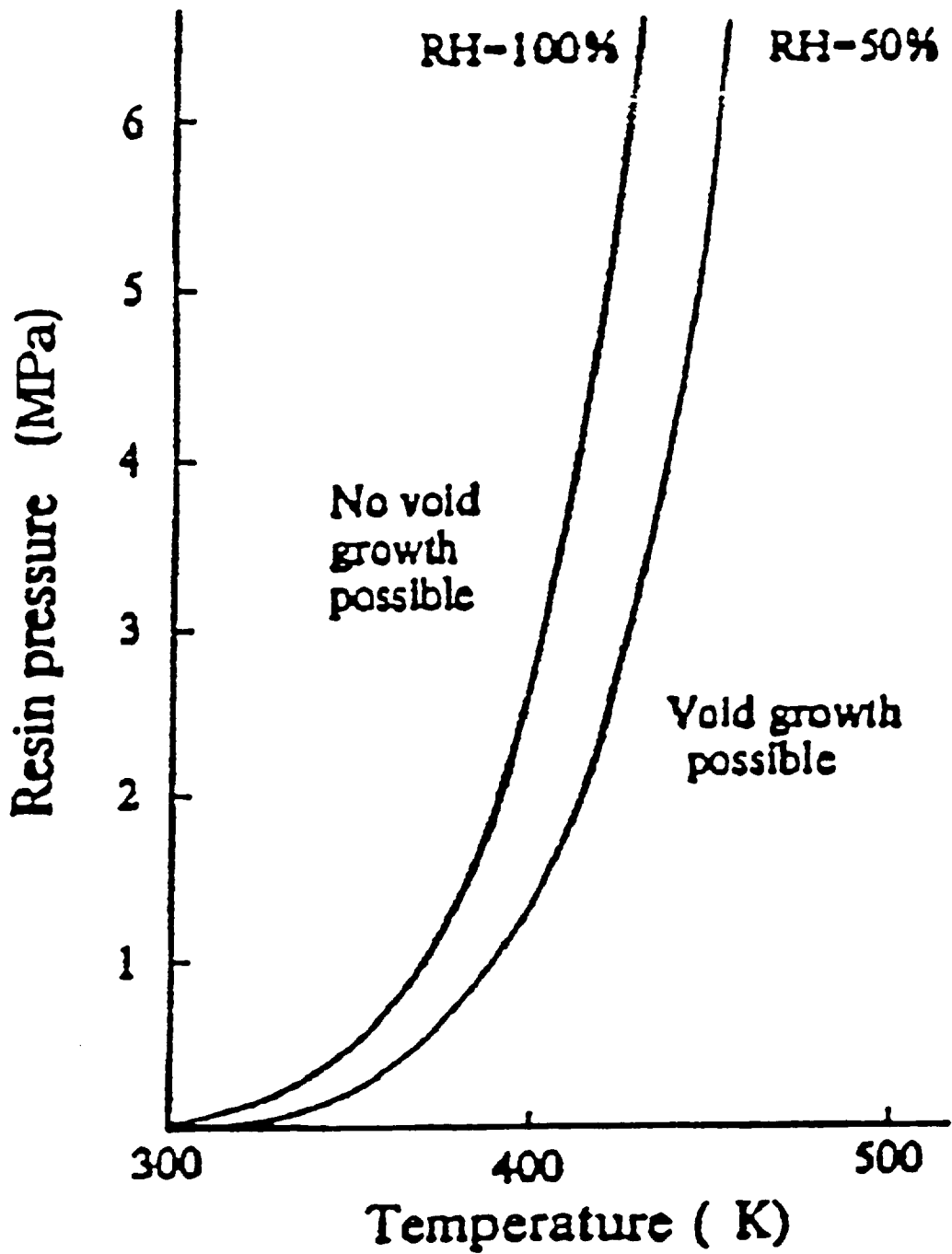

Void stability map showing applied pressure versus temperature for an epoxy at different humidities. Safe regions and regions where void growth do occur are indicated.

THERMOSET TIME-TEMPERATURE-TRANSFORMATION DIAGRAM

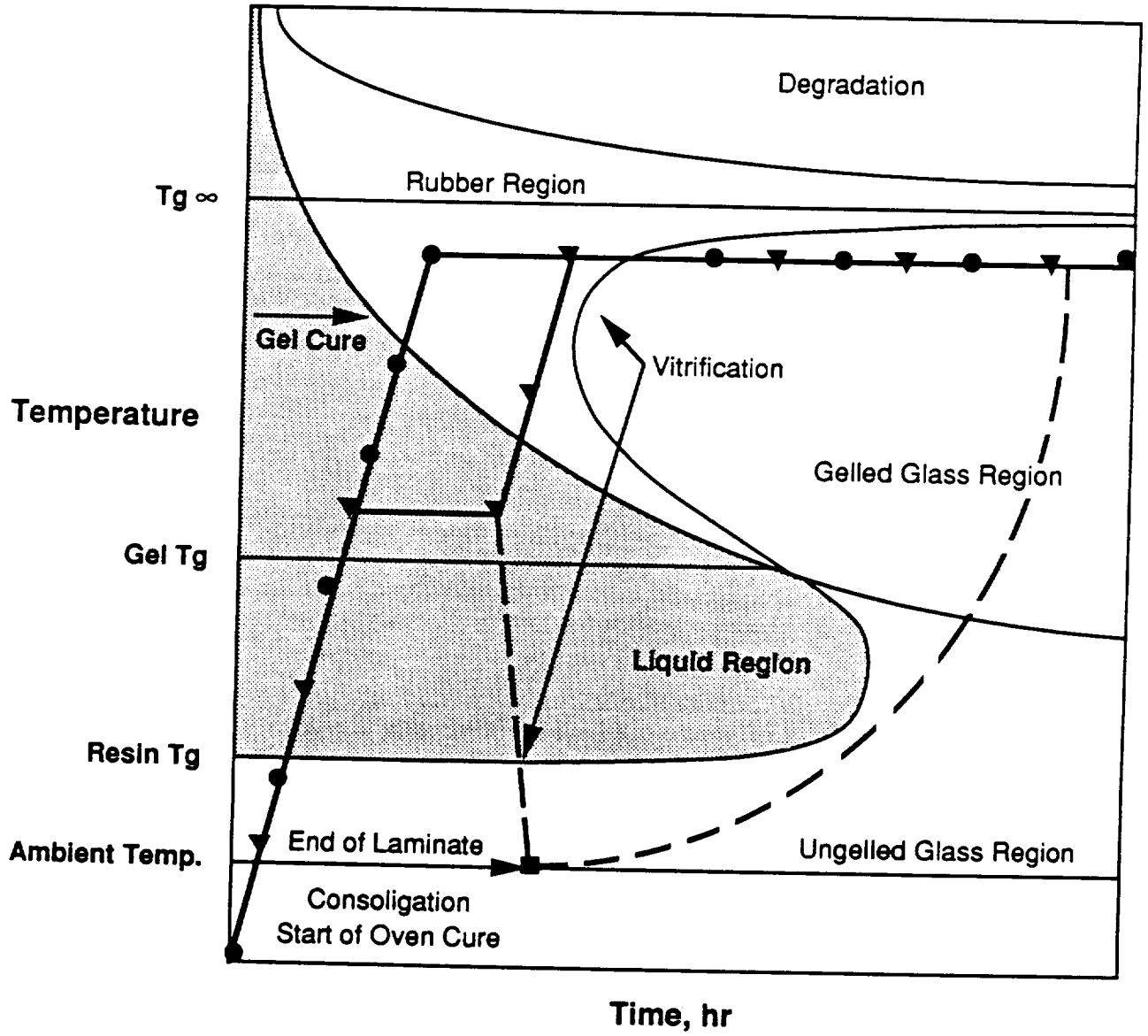

WOVEN TOWPREG CURE CYCLE

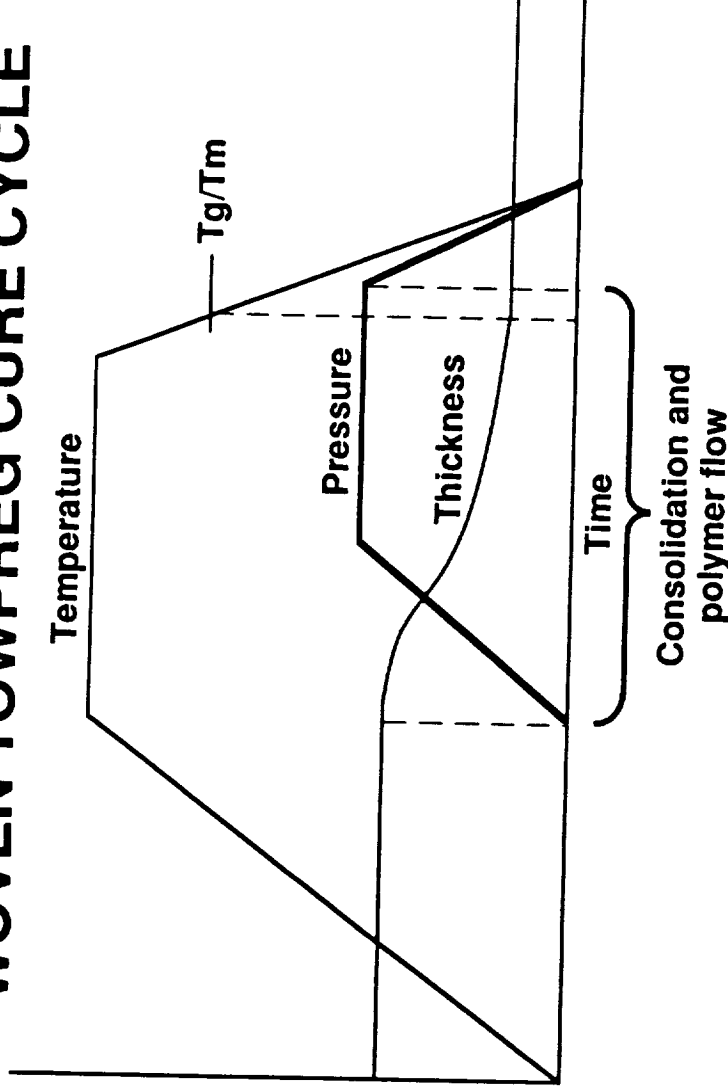

- Resin content must be optimized for fabric type.
- Resin content must be optimized for fabric type.
- Vacuum is used to eliminate air voids.
- Pressure ramp allows time for fiber movement into a compact arrangement with minimum fiber crimping and breakage.
- Pressure ramp also provides time for resin flow and adhesion.
- Holding temperature above Tg or Tm relieves elastic stresses.
- Cooling below Tg or Tm, stops consolidation before thickness curve flattens, avoids resin squeeze out and resulting dry spots.

1
2
3
4
5
6
7
8
9
10
11
12
13
14
15
16
17
18
19
20
21
22
23
24
25
26
27
28
29
30
31
32
33
34
35
36
37
38
39
40
41
42
43
44
45
46
47
48
49
50
51
52
53
54
55
56
57
58
59
60
61
62
63
64
65
66
67
68
69
70
71
72
73
74
75
76
77
78
79
80
81
82
83
84
85
86
87
88
89
90
91
92
93
94
95
96
97
98
99
100

PROCESS SELECTION

**THERMOSETS
THERMOPLASTICS
MANUFACTURING METHOD**

NEW RESIN TEST PROGRAM

Molding Cycle Development

- Matrix Resin Chemistry (Reaction Kinetics)
- Rheology (Viscoelastic Flow)
- Thermal Gravimetric Analyzer (TGA)
- Differential Scanning Calorimeter (DSC)
- Ultrasonic C-scan
- Parallel Plate Plastometer (PPP)
- Scanning Electron Microscope (SEM)

Composite Mechanical Properties

- Short Beam Shear (SBS)
- Flexural Strength - 0°, 90°
- Double Cantilever Beam (DCB)
- Tensile Strength - 0°, 90°
- IITRI Compression Strength - 0°
- Compression After Impact (CAI)

APPLICABILITY OF PREPREG TECHNOLOGY

Prepreg process	Fab. type	Polymer form						
		Epoxy		BMI	Mod. PMR	Thermoplastic		
		liquid	solid			soluble	insoluble	
Hot-melt prepreg/towpreg	Std. ^a , ATP ^b , TF ^c	✓	✓	✓	X	Limited	Limited	
Solution prepreg/towpreg	Std., ATP	✓	✓	✓	✓	Limited	Limited	X
Resin transfer molding	Preform	✓	X	✓	X	X	X	X
Powder Slurry/Dry	Std., ATP, TF, Preform	X	✓	✓	✓	✓	✓	✓
Commingle	TF, Preform	X	X	X	X	✓	✓	✓
Electropolym./vapor phase polym.	Std., ATP, TF, Preform	X	X	X	X	✓	✓	✓

^a Std. = Standard tape.
^b ATP = Advanced tow placement.
^c TF = Textile fabric.

REFERENCES

1. Procedures/Equipment

- 1.1 R.E. Gaskel, "The Calendering of Plastic Materials", J. Appl. Mech., Vol 17 pp334-336 (1950).
- 1.2 F.H. Ancher, "Calendering of Laminated Polymeric Materials", U.S. Patent No. 3,849,174, Nov. 19 (1974).
- 1.3 F.H. Ancher, "Calendering of Polymeric Materials", U.S. Patent No. 3,658,978, July 7, (1969).
- 1.4 A.A. Tseng, "Layflat Behavior and Temperature Variation in Calendering: A Review", J. Thermoplastic Composite Materials, Vol 4 pp123-139 (1991).
- 1.5 W. I. Lee and G. S. Springer, "Pultrusion of Thermoplastics," 36th International SAMPE Symposium Transactions, pp1309-1317, April (1991).
- 1.6 B.T. Astrom, P.H. Larsson and R.B. Pipes, "Experimental Investigation of a Thermoplastic Pultrusion Process", 36th International SAMPE Symposium Transactions, pp1319-1331, April (1991).
- 1.7 S.R. Taylor and W.M. Thomas, "High Speed Pultrusion of Thermoplastic Composites", 22nd International SAMPE Technical Conference Transactions, pp78-87, November (1990).
- 1.8 R.L. Anderson and C.G. Grant, "Advanced Fiber Placement of Composite Fuselage Structures", First NASA Advanced Composites Technology Conference, NASA Conference Publication 3104, Part 2, pp817-830 (1991).
- 1.9 D.O. Evans, M.M. Vaniglia and P.C. Hopkins, "Fiber Placement Process Study", 34th International SAMPE Symposium Transactions, pp1822-1833, (1989).
- 1.10 M.L. Enders and P.C. Hopkins, "Developments in the Fiber Placement process", 36th International SAMPE Symposium Transactions, pp778-790, April (1991).
- 1.11 Johnston, N. J. and St. Clair, T. L.: Thermoplastic Matrix Composites: LaRC-TPI, Polyimide-Sulfone and Their Blends. 18th International SAMPE Technical Conference. International SAMPE Technical Conference Series, 18, 53-67 (1986); SAMPLE J., 23(1), 12 (1987)
- 1.12 Johnston, N. J.; St. Clair, T. L.; Baucom, R. M.; and Towell, T. W.: Polyimide Matrix Composites: Polyimidesulfone/LARC-TPI (1:1) Blend. 34th International SAMPE Symposium and Exhibition. Science of Advanced Materials and Process Engineering Series, 34, 976-987 (1989); NASA TM-101568, March 1989.

- 1.13 Ohta, M.; Tamai, S.; Towell, T. W.; Johnston, N. J.; and St. Clair, T. L.: Improved Melt Flow and Physical Properties of Mitsui Toatsu's LARC-TPI #1500 Series Polyimide. 35th International SAMPE Symposium and Exhibition. Science of Advanced Materials and Process Engineering Series, 35, 1030-1044 (1990).
 - 1.14 Bell, J.P. J. Chang, H.W. Rhee, and R. Joseph, "Application of Ductile Polymers Coating onto Graphite Fibers," *Polymer Composites*, 8 (1) pp 46-51 (1987)
 - 1.15 Lamb, R.N., J. Baxter, M. Grunge, C. W. Kong and W.N. Unertl, "An XPS Study of the Composition of Thin Polyamide Film Formed by Vapor Deposition," *Langmuir*, 4 (2) pp249-256, (1988).
 - 1.16 Houtman, C. D.B. Granes, and K.F. Jensen, "CVD in Stagnation Point Flow", *J. Electrochem, Solid-state Science and Technology*, 133 pp961-970, (1986)
2. Preconsolidation
- 2.1 J.W. Seo and W.I. Lee, "A Model of the Resin Impregnation in Thermoplastic Composite," *J. Composite Materials*, Vol 25 pp1127-1142 (1991).
 - 2.2 G.L. Batch, "Crosslinking Free Radical Kinetics and the Pultrusion Processing of Composites", PhD Thesis, University of Minnesota (D.C. Macosko advisor) (1989).
 - 2.3 Y.R. Kim, S.P. McCarthy and J.P. Fanucci, "Compressibility and Relaxation of Fiber Reinforcements During Composite Processing", *Polymer Composites*, Vol 12, No 1, pp13-19 (1991).
 - 2.4 J.P. Fanucci, S.C. Nolet, C. Koopernoos, and Y.R. Kim, "Measurement of Internal Die Pressure Distribution During Pultrusion of Thermoplastic Composite", 22nd International SAMPE Technical Conference Transactions, pp50-64, November (1990).
 - 2.5 M.N. Ghasemi-Nejhad, R.D. Cope and S.I. Guceri, "Thermal Analysis of in-situ Thermoplastic Composite Tape Laying", *J. Thermoplastic Composite Materials*, Vol 4, pp202-45, January (1991).
 - 2.6 G. Ardichvili, "An Attempt at a Rational Determination of the Ambering of Calender Rolls", *Kautschuk*, Vol 14, pp23-28, (1938).
 - 2.7 F. Brochard, "Spreading of Liquid Drops on Thin Cylinders: the 'Manchon/Droplet' Transition", *J. Chem. Phys.*, Vol 84 No 8 pp 4464-4472 (1986).
 - 2.8 H. Van Oene, Y.F. Chang and S. Newman, "The Rheology of Wetting by Polymer Melts", *J. Adhesion*, Vol 1, pp54-68 (1969).

- 2.9 Foster-Miller, Inc. Progress Report, NASA Contract No. NAS 1-19095, July 22 (1991).
- 2.10 S.S. Bafna and D.G. Baird, "Impregnation in Thermoplastic Prepregs: Model & Experiments", 36th International SAMPE Symposium Transactions, pp1708-1719, April (1991).
- 2.11 J.D. Muzzy, "Processing of Advanced Thermoplastic Composites", ASME Manufacturing International '88 Proceedings, Vol IV, The Manufacturing Science of Composite, T.G. Gutowski, editor, pp27-39 (1989).
- 2.12 K.J. Ahn, J.C. Serferis, J.O. Price and A.J. Berg, "Permeation Measurements Through Prepreg Laminates", SAMPE Journal, Vol 27, No 6, pp19-26 (1991).
- 2.13 Throne, J. L.; Baucom, R. M. and Marchello, J. M.: Recent Developments in Dry Powder Prepregging on Carbon Fiber Tows. Fiber-Tex '89, Clemson University, Clemson, South Carolina, October, 1989.
- 2.14 Baucom, R. M. and Marchello, J. M.: LaRC Powder Prepreg System. International SAMPE Symposium and Exhibition. Science of Advanced Materials and Process Engineering Series. 35, 175-188 (1990).
- 2.15 Baucom, R.M. and Marchello, J.M.: LaRC PowderPrepreg System. SAMPE Quart., 14, July 1990.
- 2.16 Baucom, R.M. and Marchello, J.M.: Powder Towpreg Process Development. First NASA Advanced Composites Technology Conference, Seattle, Washington, October 29-November 1, 1990. NASA CP-3104, 443-455 (1991).
- 2.17 Hirt, D.E.; Marchello, J.M. and Baucom, R.M.: Study of Flexural Rigidity of Wearable Powder-Coated Towpreg. 22nd International SAMPE Technical Conference. International SAMPE Technical Conference Series. 22, 360-369 (1990).
- 2.18 Marchello, J. M. and Baucom, R. M.: Composites From Powder-Coated Thermoplastic and Thermoset Prepreg. Proceedings, Eighth Government-Industry Thermoplastic Matrix Composites Review, San Diego, California, 8, 8-15, January 1991.
- 2.19 Hugh, M.K.; Marchello, J.M.; Johnston, N.J. and Maiden J.: Weaving Towpreg Made From Dry Powder Prepregging Process. Fiber-Tex '91, North Carolina State Univ., Raleigh, NC, Oct. 15-17, 1991.
- 2.20 Hugh, M. K.; Marchello, J. M.; Baucom, R. M. and Johnston, N. J.: Composites From Powder-Coated Towpreg: Studies With Variable Tow Sizes. 37th International SAMPE Symposium and Exhibition. Science of Advanced Materials and Process Engineering Series. 37. (1992).

1
2
3
4
5
6
7
8
9
10
11
12
13
14
15
16
17
18
19
20
21
22
23
24
25
26
27
28
29
30
31
32
33
34
35
36
37
38
39
40
41
42
43
44
45
46
47
48
49
50
51
52
53
54
55
56
57
58
59
60
61
62
63
64
65
66
67
68
69
70
71
72
73
74
75
76
77
78
79
80
81
82
83
84
85
86
87
88
89
90
91
92
93
94
95
96
97
98
99
100

- 2.21 Hugh, M.K.; Marchello, J.M. and Johnston, N.J.: Weavability of Dry Polymer Powder Towpreg. Third Advanced Composites Technology Conference, Long Beach, CA, June 8-11, 1992.
- 2.22 Sandusky, D.A., Marchello, J.M., Baucom, R.M. and Johnston, N.J.: Customized ATP Towpreg, 24th International SAMPE Technical Conference. International SAMPE Technical Conference Series, 24, (1992).
- 2.23 Sandusky, D. A.; Baucom, R. M. and Marchello, J. M.: Ribbonized Fiber Architecture and Manufacturing Procedures. Patent Application submitted January 27, 1992.
- 2.24 Iyer, S.R. and L.T. Drzal, "Manufacture of Powder-Impregnated Premoplastic Composites," J. Thermoplastics Composite Materials, 3 pp325-355, October (1990).
- 2.25 Van West, B.P., R.B. Pipes, M. Keefe and S.G. Adrani, "The Draping and Consolidation of Commingled Fabrics," Composites Manufacturing 2 (1) pp 10-22, March (1991).
- 2.26 Baucom, R.M. J. Snoha and J.M. Marchello, "Process for Application of Powder Particles to Filamentary Materials," U.S. Patent 5,057,338, October 15, 1991.

3. Process Selection

- 3.1 Baucom, R. M.; Johnston, N. J.; St. Clair, T. L.; Gleason, J. R.; Nelson, J. B. and Proctor, K. M.: Preparation of Processable Aromatic Polyimide Thermoplastic Blends. NASA Tech Brief LAR-13695, August 1987.
- 3.2 Towell, T. W.; Hirt, D. E.; and Johnston, N. J.: LARC-TPI 1500 Composites Fabricated Using an Aqueous Slurry Process. 22nd International SAMPE Technical Conference. International SAMPE Technical Conference Series, 22. 1156-1169 (1990).
- 3.3 Towell, T. W.; Johnston, N. J.; St. Clair, T. L. and Hirt, D. E.: LARC-TPI 1500 Composites Fabricated From Slurry-Processed Prepreg, J. Comp. Mtls., in preparation.
- 3.4 Johnston, N. J.; St. Clair, T. L.; Baucom, R. M. and Gleason, J. R.: Preparing Composite Materials From Matrices of Processable Aromatic Polyimide Thermoplastic Blends., U. S. Patent, 5,004,575, April 2, 1991.
- 3.5 Johnston, N. J. and Towell, T. W.: Preparing Polymeric Matrix Composites Using an Aqueous Slurry Technique. Patent Application LAR-14771-1, Submitted November 5, 1991.
- 3.6 Baucom, R. M. and Marchello, J. M.: LaRC Dry Powder Towpreg Systems. NASA TM 102648, April 1990.

1 2 3 4 5 6 7 8 9 10 11 12 13 14 15 16 17 18 19 20 21 22 23 24 25 26 27 28 29 30 31 32 33 34 35 36 37 38 39 40 41 42 43 44 45 46 47 48 49 50 51 52 53 54 55 56 57 58 59 60 61 62 63 64 65 66 67 68 69 70 71 72 73 74 75 76 77 78 79 80 81 82 83 84 85 86 87 88 89 90 91 92 93 94 95 96 97 98 99 100

- 3.7 Marchello, J. M. and Baucom, R. M.: LaRC Powder Towpreg Process. 36th International SAMPE Symposium and Exhibition. Science of Advanced Materials and Process Engineering Series, 36, 68-80 (1991).
- 3.8 Baucom, R. M.; Snoha, J. and Marchello, J. M.: "Process for Application of Powder Particles to Filamentary Materials" U. S. Patent 5,057,338, October 15, 1991.
- 3.9 Mallick, P.K. Fiber-Reinforced Composites: Materials Manufacturing, and Design, pp319-379, Marcel Decker, Inc., (1988).
- 3.10 Nelson, K.M., J.A.E. Manson and J.C. Seforis, "Compression Thermal Analysis of the Consolidation Process for Thermoplastic Matrix Composites," J. Thermoplastic Composite Materials, 3 pp216-231, July (1990).

1
2
3
4
5
6
7
8
9
10
11
12
13
14
15
16
17
18
19
20
21
22
23
24
25
26
27
28
29
30
31
32
33
34
35
36
37
38
39
40
41
42
43
44
45
46
47
48
49
50
51
52
53
54
55
56
57
58
59
60
61
62
63
64
65
66
67
68
69
70
71
72
73
74
75
76
77
78
79
80
81
82
83
84
85
86
87
88
89
90
91
92
93
94
95
96
97
98
99
100