

N92-22532

SMALL ENGINE TECHNOLOGY PROGRAMS

Richard W. Niedzwiecki

SUMMARY

This paper describes small engine technology programs being conducted at the NASA Lewis Research Center. Small gas turbine research, cosponsored by NASA and the Army, is aimed at general aviation, commutercraft, rotorcraft, and cruise missile applications. The Rotary Engine program is aimed at supplying fuel flexible, fuel efficient technology to the general aviation industry, but also has applications to other missions. The Automotive Gas Turbine (AGT) and Heavy-Duty Diesel Transport Technology (HDTT) programs are sponsored by the Department of Energy (DOE). The Compound Cycle Engine program is sponsored by the Army. There is a strong element of synergism between the various programs in several respects. All of the programs are aimed towards highly efficient engine cycles, very efficient components, and the use of high-temperature structural ceramics. This research tends to be generic in nature and has broad applications. The HDTT, rotary technology, and the compound cycle programs are all examining approaches to minimum heat rejection, or "adiabatic" systems employing advanced materials. The AGT program is also directed towards ceramics application to gas turbine hot section components. Turbomachinery advances in the gas turbine programs will benefit advanced turbochargers and turbocompounders for the intermittent combustion systems, and the fundamental understandings and analytical codes developed in the research and technology programs will be directly applicable to the system projects.

INTRODUCTION

Ongoing and proposed small engine programs are indicated in figure 1. The Automotive Gas Turbine (AGT) and Heavy-Duty Diesel Transport Technology (HDTT) programs are sponsored by DOE, and the Compound Cycle Turbine Diesel (CCTD) by the Army. There is a strong element of synergism between the various programs in several respects.

All of the programs presently include or will include research in high-temperature structural ceramics. This research tends to be generic in nature and has broad applications. The HDTT, the rotary technology, and the CCTD are all examining approaches to minimum heat rejection, or "adiabatic" systems employing advanced materials. The AGT program is also directed towards ceramics application to gas-turbine hot-section components.

Turbomachinery advances in the gas turbine programs will benefit advanced turbochargers and turbocompounders for the intermittent combustion systems, and the fundamental understandings and analytical codes developed in the R&T programs will be directly applicable to the system projects.

SMALL ENGINE EFFICIENCY

Previous investments in technology have led to significant efficiency gains for large engines. These gains have resulted from improved cycles, components, and materials. However, much of these technologies has not been transferable to smaller engines (fig. 2). As engine power size decreases, performance decreases because of the combined effects of increased relative clearances, lower Reynolds number, increased relative surface roughness, and other factors. These adverse effects are particularly noticeable below 200 shaft horsepower (shp). Small engines employ different component configurations such as centrifugal compressors, reverse flow combustors, and radial turbines to minimize these effects. Future large turbofan engines designed for ultra-high bypass ratios and higher cycle pressure ratios (greater than 50:1) will be limited in performance by some of the same size related problems which presently limit the performance of the small engines. This is a result of the inherent reduction in core engine flow size associated with the higher bypass ratio and the higher core pressure ratio, all of which reduces the turbomachinery size and the combustor length and volume. To counter the losses associated with the small turbomachinery blading, such things as replacing the back stages of the typically all-axial compressors with a centrifugal stage is now being considered, following the same trends as for small engines.

SMALL ENGINE TECHNOLOGY OPPORTUNITIES

Small engines are used in a broad spectrum of aeronautical applications including helicopters, commuters, general aviation airplanes, and cruise missiles. In exploring engine types to satisfy these applications it has been determined that all of the engine types being researched have the potential of significantly improved efficiency. Shown in figure 3 is a plot of thermal efficiency and shaft horsepower. Gas turbines are considered prime candidates for horsepower ranges of 500 shp and higher. Their potential in efficiency improvement, over current engines, is of the order of 50 percent. The sources of this improvement will be presented later. The rotary engine is considered a prime candidate for missions up to 500 shp, but is not limited to that size range. Their potential for efficiency improvement is similar to the gas turbine. The compound cycle diesel is being considered for missions requiring engines in the 750 to 2000 shp class. Their potential for improvement is comparable to the other engine types being researched. The chart in figure 4 illustrates the reasons for the keen military interest in substantially reducing specific fuel consumption (SFC) of their engines.

Many programs proposed previously have tended to be "evolutionary," focused on incremental improvements in component capabilities. This objective reflects our intent to establish a program which will lead to a major advance in small engine technology. Our target is to improve fuel consumption by 40 percent and to reduce DOC by 10 percent through the use of improved materials and design concepts. We believe that "revolutionary" powerplant improvements will have a truly significant impact, and will lead to a new generation of airframes with greatly expanded capabilities.

SMALL ENGINE COMPONENT TECHNOLOGY (SECT) STUDIES

The Small Engine Component Technology (SECT) studies were conducted, under joint NASA/Army funding, to provide a critical assessment by the small turbine industry on the technology needs for the year 2000 engines. The results of the studies will have a significant impact on the technology to be pursued in future programs. Study contractors were Allison, Avco Lycoming, Garrett, Teledyne CAE, and Williams International. General Electric and Pratt & Whitney also conducted parallel studies and made the results available for the technology assessments. Missions studies included rotorcraft in the 500 to 1000 hp size; general aviation/commuter missions in the 500 to 1000 hp size; auxiliary power units in the 300 to 500 hp size; and cruise missiles in the 200 to 1000 lb T size.

Study results in terms of benefits, high-payoff research areas, and national benefits achieved from the evolved research are shown in the chart in figure 5 for the various missions. Other component technologies identified as critical to achieving significant fuel savings and DOC/LCC reductions include bearings, shafts, seals, gearboxes, and slurry fuel combustion for the cruise missile engines.

IMPACT OF ADVANCED TECHNOLOGY ON CYCLE PERFORMANCE

Figure 6 presents two engine performance maps. The top map presents the performance for a state-of-the-art (SOA) 800-shp (uninstalled) simple-cycle gas turbine. It is used as a reference for comparison to advanced cycles. A turbine inlet temperature of 2200 °F and a pressure ratio of 14:1 were assumed as representative for the SOA engine. In addition, SOA component efficiencies and combustor/turbine cooling requirements were assumed. The brake specific fuel consumption (BSFC) for these conditions is approximately 0.43 lb/shp-hr and specific power approximately 180 shp/lb/sec.

The bottom engine map presents the performance for an advanced simple cycle for comparison to the SOA. For the advanced engine, advanced component efficiencies were assumed, together with higher operating pressures to 24:1, higher temperatures to 2600 °F, and uncooled ceramics. The advanced BSFC of 0.36 lb/hp-hr is 17 percent less than the SOA, and its specific power is 55 percent higher. Of the 17 percent improvement, 8 percent is attributed to advanced component efficiencies, 4 percent is due to the higher cycle pressure, temperature, and reduced turbine coolant penalty, and 5 percent results from totally eliminating the coolant penalty by using uncooled ceramics. Uncooled ceramics also have the potential for reducing costs.

Figure 7 presents the performance for an advanced regenerated cycle in comparison with the state-of-the-art simple cycle and the advanced simple cycle. Again, advanced component efficiencies were assumed, together with the high turbine inlet temperature of 2600 °F and uncooled ceramics. In terms of BSFC, the advanced regenerated cycle provides the potential for a very significant 37 percent reduction over the state-of-the-art simple cycle and some increase in specific power. Note, however, that the optimum cycle pressure ratio for the regenerated cycle is much lower than that for the advanced simple

cycle and results in fewer compression stages required. Regenerative cycles could utilize either a rotary regenerator or a stationary recuperator.

Although these potential performance gains are quite large, they must be examined in a representative mission model, taking into consideration projected changes in engine size, weight, cost, and other factors before the real benefit of the advanced small engine technology program can be assessed. Because of the diversity of small engine applications, several representative missions have been selected for study.

COMPRESSOR EFFICIENCY

The curve in figure 8 was derived from actual data. It is a plot of compressor polytropic efficiency as a function of compressor exit corrected flow in pounds per second. The solid line represents advanced, current technology. The 10-lb/sec efficiency value of 92 percent is energy efficient engine data. As shown, reducing flow size causes significant decreases in efficiency, until at 1 lb/sec the efficiency drops to approximately 78 percent. Identifying the causes for the efficiency falloff and minimizing their effects are major thrusts of the compressor program. Aggressive program goals are indicated by the dashed line.

COMPRESSOR TECHNOLOGY PROGRAM

Major thrusts of the compressor technology program are the following (fig. 9):

- (1) Doing axial and centrifugal compressor research to achieve higher pressure ratios, increased efficiency, and reduced number of stages with higher loading per stage
- (2) Quantifying and minimizing performance degradation factors accruing with reductions in flow size
- (3) Evolving improved design techniques through the development of improved analytical models and codes
- (4) Verifying and improving analytical models through the use of advanced diagnostics including laser anemometry

The Scaled Centrifugal Compressor program described in figure 10 was conducted to determine performance degradation with flow size. A 25-lb/sec centrifugal compressor was scaled down to a 10-lb/sec size. It was then attempted to scale the 10-lb/sec compressor down to a 2-lb/sec size. This was not possible, principally because of the wall thickness. A 2-lb/sec "doable" compressor was then designed and scaled to the 10-lb/sec size. Research was then conducted with thin- and thick-blade 10-lb/sec compressors and the thick-blade 2-lb/sec compressor wheels. The performance degradation factors shown in figure 11 were quantified for the three compressor wheels. Results were reported at the San Diego AIAA meeting.

Figure 12 shows the peak efficiency loss that occurs as the Reynolds number is varied for the 2-lb/sec and 10-lb/sec centrifugal compressors. The data from both compressors fall along a straight line. This indicates that the scaling laws hold within this size range. One of the problems in designing efficient small compressors is that they operate at lower Reynolds numbers which inherently produce increased inefficiency.

TURBINE EFFICIENCY

Figure 13 is a plot of turbine efficiency as a function of turbine inlet corrected flow. Figure 13(a) is for gas generator turbines. The dashed line represents current gas generator turbine technology for axial turbines. Actual data were used to construct this plot, with the higher flow rate incorporating energy efficient engine data. As can be seen, an efficiency dropoff of over 4 percent occurs as size is reduced. The top, shaded-in curve represents program goals for axial turbines. It also represents radial turbine data. Although they are very efficient, radial turbines are not currently on flying engines because other technologies they require have not evolved. The prime technology need for radial turbines is a method for satisfactorily cooling them. Figure 13(b) represents the current state of the art for axial power turbines (dashed line). Program goals are shown by the solid line.

SMALL TURBINE ENGINE TECHNOLOGY PROGRAM

Figure 14 displays the principal thrusts of the turbine program. Both axial and radial turbine research are being pursued, with the emphasis on radial turbines. The general approach of identifying, quantifying, and minimizing loss mechanisms (which occur with decreasing size, evolution of improved analytical codes for turbine design, and verification of the improved codes through the implementation of advanced diagnostics) is similar to that described previously for compressors.

Figure 15 summarizes progress achieved under a joint NASA/DOE project. The work consisted of an advanced structural analysis code applicable to the design of high-temperature structural ceramic engine components. Currently, the code is in the process of being verified. However, even at this early stage, the code has been applied to radial turbine wheels with the results being used to identify the most promising concepts.

Small Warm Turbine Test Facility

The modern facility shown in figure 16 can evaluate the aerodynamic and cooling performance of small and medium size axial, radial, or mixed-flow turbines while duplicating all significant similarity parameters. Unique instrumentation includes onboard rotor measurements of pressure and temperature, flow surveys between blade rows during stage operation, and a high-speed in-line torque meter. The main facility operating parameters are as follows: inlet temperature, 800 °F; coolant temperature, -50 °F; inlet pressure, 125 psig; flow rate, 10 lbm/sec; speed, 60 000 rpm; and power absorption, 1250 hp.

NASA/Allison Cooled Radial Turbine

A cooled high-temperature radial turbine (fig. 17) will be experimentally evaluated in a warm turbine test facility at the NASA Lewis Research Center. The turbine is designed with an uncooled ceramic stator with an inlet temperature of 2500 °F and mass flow of 4.56 lbm/sec. The rotor is designed with 4.5 percent cooling air, a work level of 185 Btu/lbm, and an efficiency of 86 percent. Three-dimensional heat transfer and aerodynamic analyses were performed on the turbine. These predictions will be verified by comparison with experimental results. Detailed measurements of temperature and pressure will be made on the rotor surface and within the cooling channel. Verifying the region of separation along the hub of a radial turbine and predicting rotor blade temperatures are of particular importance in future turbine designs.

SMALL COMBUSTOR TECHNOLOGY

Small gas turbine combustors currently operate at efficiencies near 100 percent at all landing-takeoff cycle operating conditions - efficiency is not a problem. However, advanced cycle engines will require increased temperature and pressure capability, reduced air coolant requirements for liners, and increased durability of injectors and liners. The research program in place is addressing all of those needs. Also required will be combustion systems which produce uniform exit temperature distributions - approximately twice the uniformity currently achievable.

Numerous small combustor types are employed. Three are shown in figure 18. Axial combustors are scaled-down versions of large combustors. Flow proceeds axially through the combustor. Reverse flow combustors are the most common variety. Compressor discharge air exhausts into a plenum, which then feeds the various combustor zones according to a preset schedule. This combustor design is popular because it packages well in small engines. However, it also has the greatest amount of hot-section surface area, liners, and reverse flow turn, and is thus the most difficult to cool. Radial outflow combustors are reverse flow types but contain several significant differences. They usually increase in volume radially, and fuel is injected through the spinning shaft. Thus fuel injectors are not required. This combustor type is used in cruise missile engines.

A recent combustion research accomplishment is shown in figure 19. An advanced combustor liner, the ceramic matrix, was developed. This combustor utilizes only backside cooling air - no chargeable air injected through the liner is required for keeping the liner within temperature limits. The concept employs a thick ceramic coating impregnated on a pliable felt metal. The pliable metal reduces stresses imposed on the ceramic, and supplies a heat shield to confine combustion temperatures. Short-duration performance tests of this concept were conducted to over 2600 °F, which is 300 to 400 °F hotter than current combustor temperatures. Current activities are underway in-house and under an Army contract to optimize the implementation of this concept.

DOE/NASA ADVANCED GAS TURBINE TECHNOLOGY

The Automotive Gas Turbine (AGT) program (fig. 20) began in 1980. Fiscal year 1986 was the final funding year, though funds were expended through fiscal year 1987. Also in fiscal year 1987 a new program was initiated; this will be described later in this section.

Figure 21 illustrates the Allison AGT 100 test bed engine. This regenerated, two-shaft engine has a maximum rotor speed to 86 000 rpm and has been operated to 2100 °F for 6 hour.

Figure 22 illustrates the ceramic components incorporated in the Allison engine. Similar components were also fabricated and tested in the Garrett engine. Ceramic materials used were silicon carbides, silicon nitrides, aluminum silicates and zirconias. Numerous contractors, both U.S. and foreign, were used to supply ceramic parts. Some of the contractors were Standard Oil, Norton, GTE Labs, AiResearch Casting, Corning, Coors, Pure Carbon, and AC Spark Plug. Development of new technologies and capabilities has been restricted to U.S. corporations. This approach, which will be continued in the future, has led to a significant improvement in national production capability. This capability is essential in applying ceramics of sufficiently high quality for both automotive and aeronautical missions.

In addition to providing viable alternatives to the automotive industry, much of the technology evolved is also applicable to aeronautical missions. This is especially true of the ceramics and composites research, the analytical design tools, and the component fabrication processes and procedures.

Figure 23 shows an all-ceramic Garrett AGT 101 engine that has been operated for 85 hours at 2200 °F. At that point, rotor damage was sustained. These results illustrated both the promise of ceramic components as well as the need for future research to develop long-life components.

The FY 1987 new start program, the Advanced Turbine Technology Applications Project (ATTAP), focuses on ceramic technology development. Major technological thrusts of the program are high-temperature structural ceramics, high-temperature heat exchangers, low-emission combustors, high-temperature bearings, and small, efficient turbomachinery. The goal of this program, which includes 5-year cost share contracts with Allison and Garrett, is to develop and demonstrate structural ceramic components in an automotive turbine engine environment up to 2500 °F peak temperature conditions.

ROTARY ENGINES

The target of the rotary engine program (fig. 24) is to improve fuel consumption by 40 percent, and to reduce engine weight while providing multifuel (jet fuel) for general aviation and other small engine aeronautical missions.

Rotary engines offer several advantages over piston engines for small engine aircraft applications. These include the following:

(1) They are potentially more fuel efficient.

(2) They are inherently more fuel flexible. Their implementation and operation with jet A fuel could make aviation gasoline obsolete.

The rotary program includes large contractual activities with John Deere Co. as well as grants and contracts with MCI, MTU, ADAPCO, Adiabatics, PDA Engineering, and MIT. Understanding the combustion processes and evolving the technology for advanced combustion systems are the key to advanced, high-performance rotary engines.

Advanced, fuel-efficient rotary engines will require evolution of lightweight rotors and housing, adiabatic components, and turbocompounding. Figure 25 summarizes recent progress with the NASA/Deere stratified-charge rotary engine and indicates program goals. The parameter used is brake specific fuel consumption. In 1986, initial tests with a high-speed electronic fuel control produced BSFC values to 0.51. In fiscal year 1987, BSFC was reduced to 0.46 through application of validated combustor cones and optimization of the electronic fuel control system. The overall BSFC goal is 0.35 at 160 hp and 8000 rpm. To achieve this goal turbocompounding, adiabatic components, and a lightweight rotor, with reduced friction, will be required.

COMPOUND CYCLE ENGINE

The Compound Cycle Engine (fig. 26) program is planned in three parts:

(1) Part 1, currently in progress, is aimed at establishing the technology base for a long-life diesel core. Activities focus on single-cylinder diesel research.

(2) Part 2 is aimed at validating life, minimizing heat rejection losses, optimizing intercylinder dynamics, and verifying diesel performance predictions.

(3) Part 3 will demonstrate the integrated turbine/diesel system concept and performance.

Since the program is in its initial phases, no engine currently exists. Figure 27 is a sketch illustrating main features of an application of the technology. It is anticipated that the gas turbine components technologies will be available from the small gas turbine program. The flow diagram illustrates the features of the integrated cycle.

Planned operation is as follows. Flow goes into the compressor (10.6:1) and through an aftercooler. The aftercooler reduces the air temperature to the cylinder thus lowering ring reversal and exhaust valve temperatures. (Most importantly, it will enhance life.) The exhaust from the diesel cylinder then goes to the gas generator and power turbines. Approximately one-fourth of the power is generated by the turbomachinery and three-fourths by the diesel.

DOE/NASA HEAVY-DUTY TRANSPORT TECHNOLOGY PROJECT

The Heavy-Duty Transport Technology Project (fig. 28) is DOE funded and technically managed by NASA. Program activities are being performed almost entirely under grant and contract. Key problem areas requiring research are exhaust gas heat recovery, adequate piston seals, low emission performance, engine friction and wear, and thermal insulation implementation.

There exists much synergism between this program and the aeronautics programs - especially the Compound Cycle Engine program. Areas where much technology transfer is expected to occur are as follows:

(1) Thermal barrier coatings for heavy-duty diesel engines. Preliminary results indicate that plasma-sprayed coatings are viable alternatives to monolithic ceramics for in-cylinder insulation in the adiabatic diesel of the future.

(2) Evolution of piston ring/cylinder liner materials for advanced diesel engines. Ten candidate materials have been evaluated to date. Of those, K-162B and TIC had the lowest wear rates. They generated pseudo-lubricants. K-162B had the lowest dynamic friction coefficient.

SMALL ENGINE RESEARCH SUMMARY

A summary of the small engine programs being conducted at Lewis Research Center is given in figure 29. Although each of these programs has specific objectives, there is a strong element of synergism between the various programs in several respects. All of the programs presently include or will include research in high-temperature structural ceramics. This research tends to be generic in nature and has broad applications. The HDTT, the rotary technology and the CCTD are all examining approaches to minimum heat rejection, or "adiabatic" systems employing advanced materials. The AGT program is also directed towards ceramics application to gas turbine hot-section components. Turbomachinery advances in the gas turbine programs will benefit advanced turbochargers and turbocompounders for the intermittent combustion systems, and the fundamental understandings and analytical codes developed in the R&T programs will be directly applicable to the system projects.

SMALL ENGINE TECHNOLOGY PROGRAMS

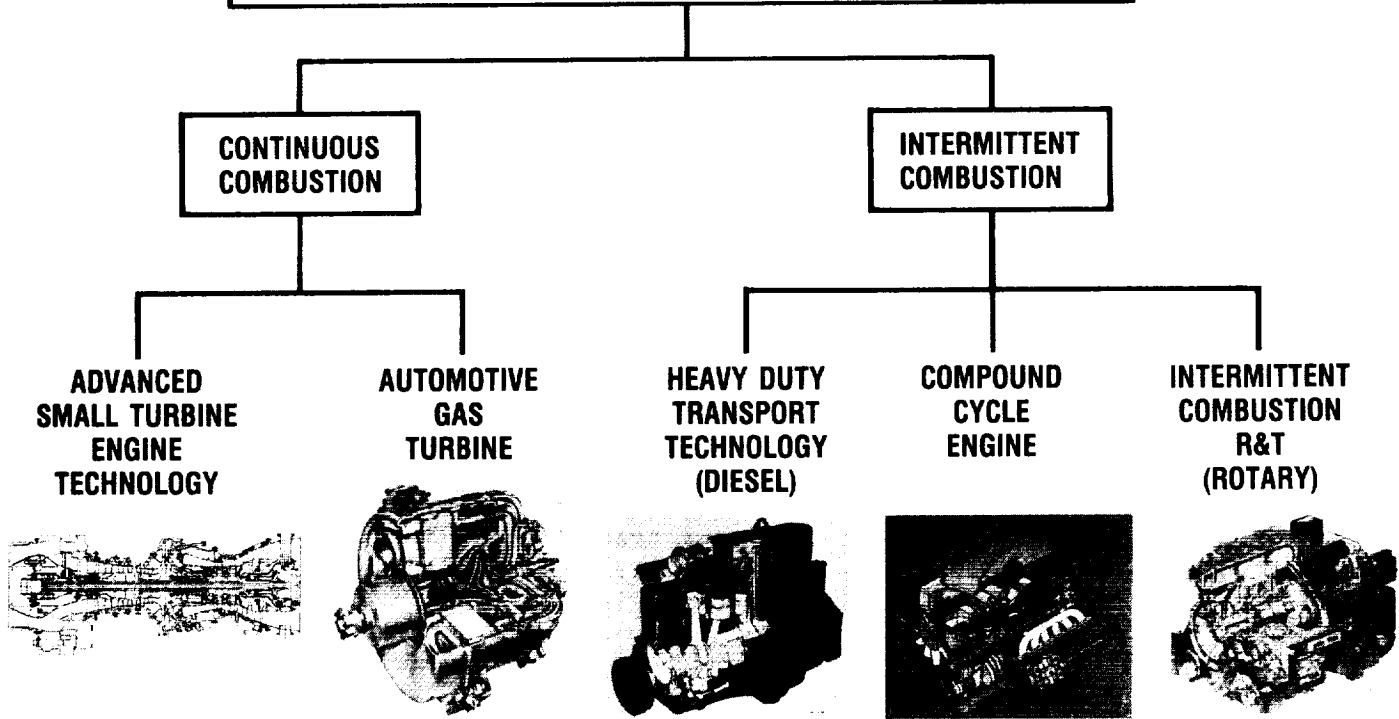

CD-87-29880

Figure 1. - Small engine technology programs.

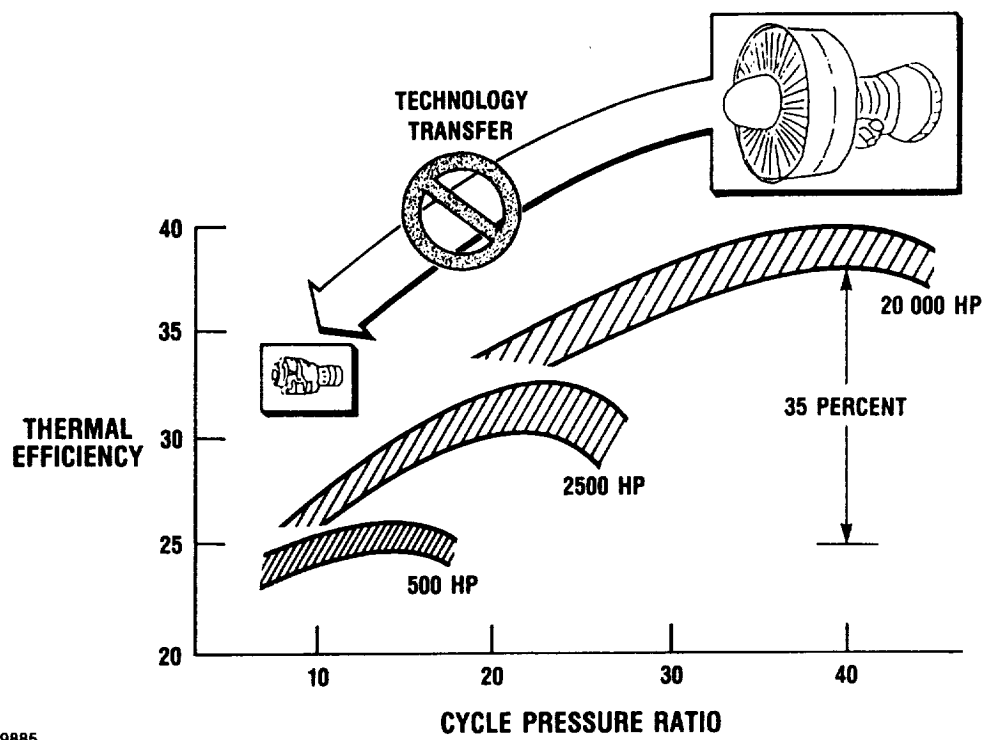

CD-87-29885

Figure 2. - Small engine efficiency.

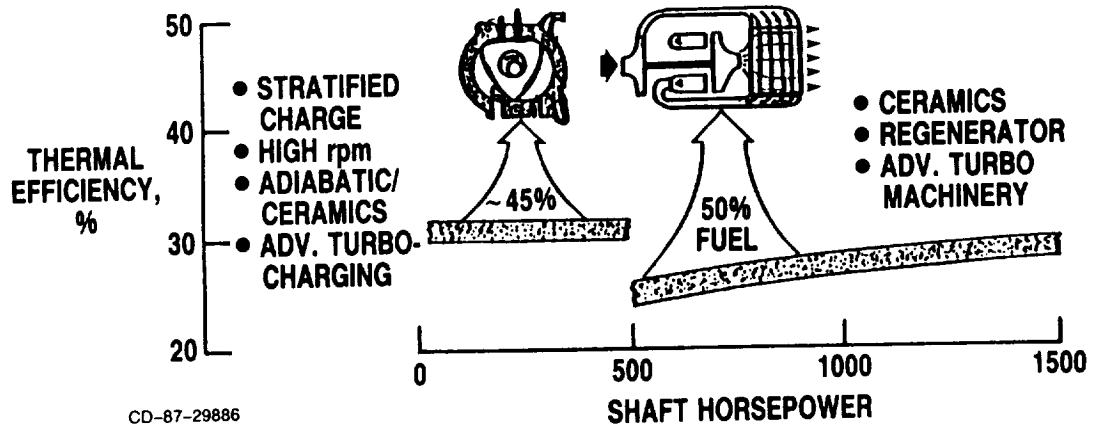
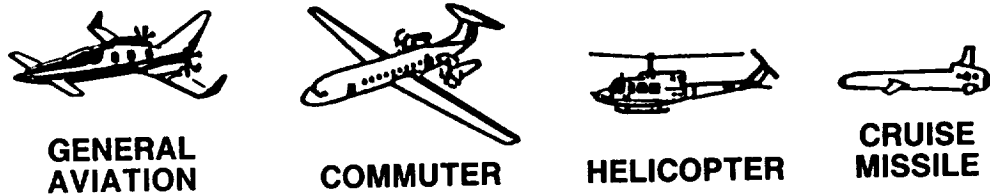

CD-87-29886

Figure 3. - Small engine technology opportunities.

- **FUEL IS 70 PERCENT OF TONNAGE SHIPPED**
- **ARMOR/MECH/INF DIVISIONS**
 - AVIATION: 100,000 GAL/DAY PER DIV
 - GROUND: 50,000 GAL/DAY PER DIV
- FOR 15,000 MAN DIVISION, 10 GAL/DAY/MAN PER DIV
- **AIR ASSAULT DIVISION**
 - AVIATION: 320,000 GAL/DAY PER DIV
 - GROUND: 20,000 GAL/DAY PER DIV
- FOR 15,000 MAN DIVISION, 22 GAL/DAY/MAN PER DIV

• **A 50 PERCENT SAVINGS IN AVIATION FUEL CAN SIGNIFICANTLY REDUCE TOTAL TONNAGE SHIPPED, THUS INCREASING MISSION CAPABILITY AND FLEXIBILITY.**

CD-87-29887

Figure 4. - Impact of fuel on military mission flexibility from battlefield scenarios.

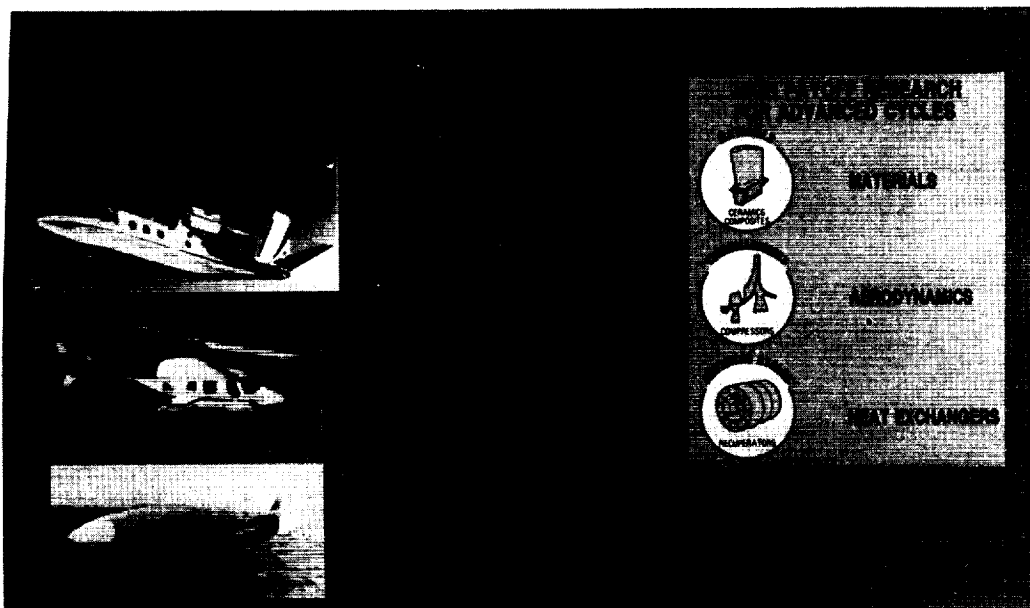

NATIONAL BENEFITS

- \$1-\$3 BILLION SAVINGS IN OPERATING COSTS IN 15 YEARS.
- 2-3 YEAR PAYBACK FOR R&D INVESTMENT.
- SIGNIFICANT MILITARY ADVANTAGES.
- STRENGTHEN U.S. COMPETITIVE EDGE IN FUTURE WORLD MARKET.

CD-87-29889

Figure 5. - Small engine component technology (SECT) studies (joint NASA/Army program).

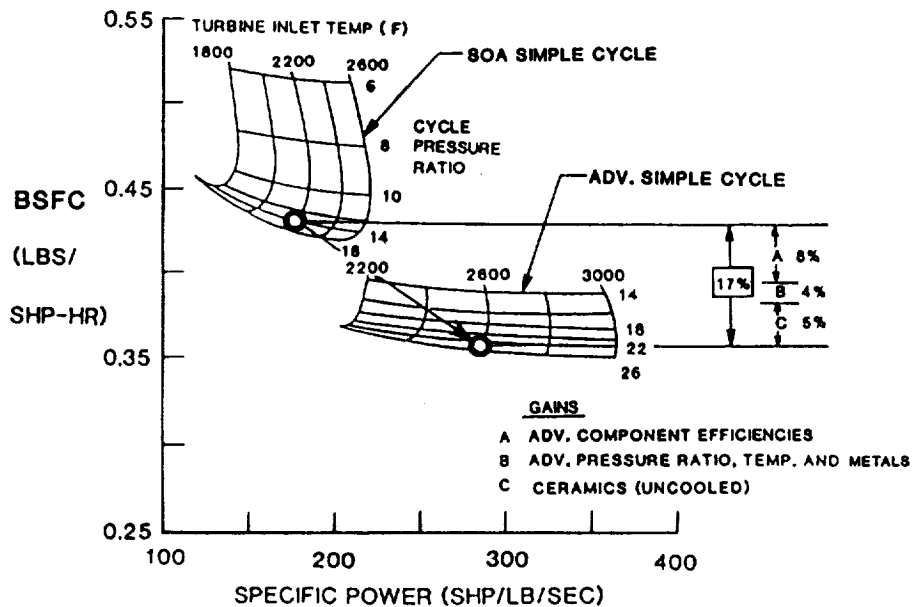

CD-87-29890

Figure 6. - Comparison of engine performance maps for state-of-the-art and advanced simple-cycle engines.

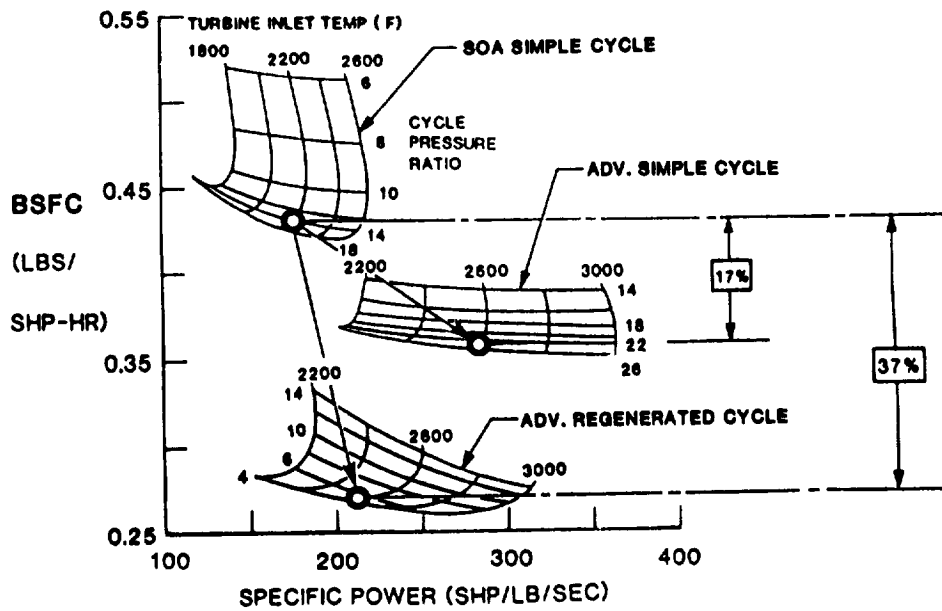

CD-87-29891

Figure 7. - Performance of advanced regenerated cycle in comparison with state-of-the-art and advanced simple cycles.

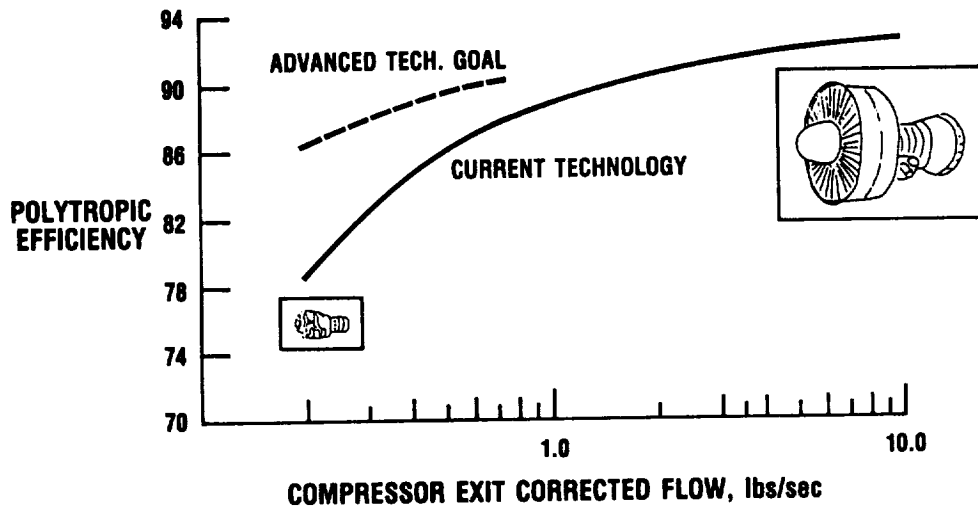

CD-87-29892

Figure 8. - Compressor efficiency.

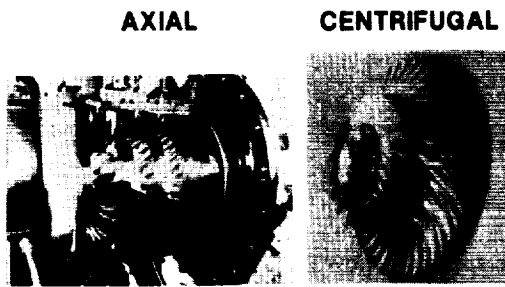

- HIGHER PRESSURE RATIOS
- INCREASED EFFICIENCY
- REDUCE NUMBER OF STAGES

PERFORMANCE DEGRADATION FACTORS

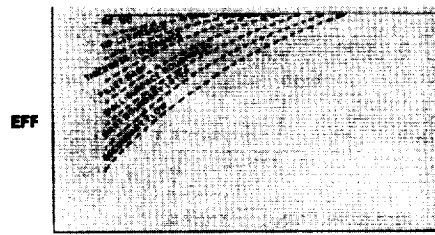

QUANTIFY/MINIMIZE EFFECT WITH FLOW SIZE

COMPUTER-AIDED ANALYSIS



DEVELOP ANALYTICAL MODELS AND CODES

LASER ANEMOMETRY

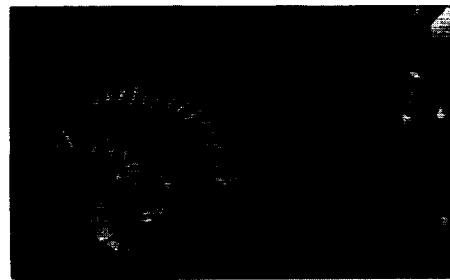

OBTAIN DETAILED INTERNAL FLOW MEASUREMENT

CD-87-29893

Figure 9. - Compressor technology.

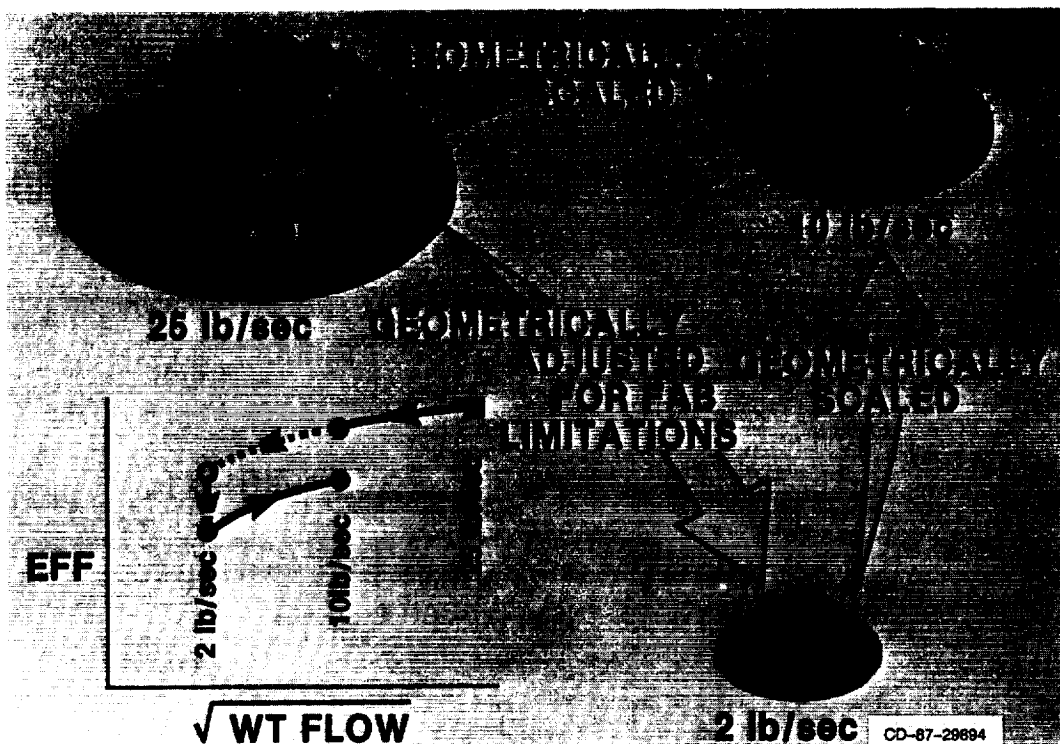
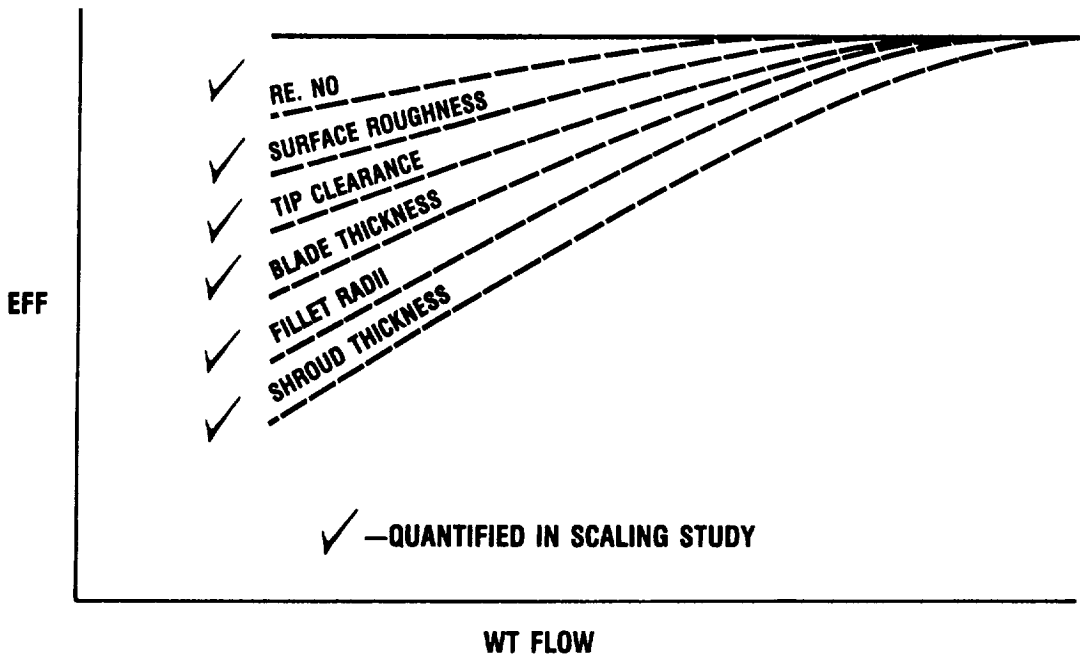
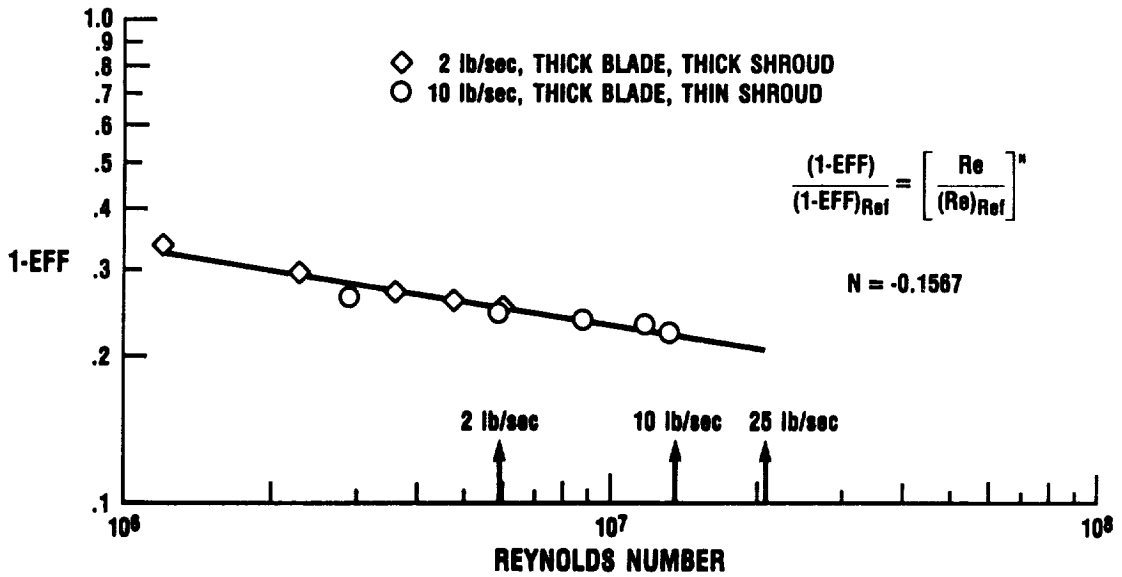

Figure 10. - Scaled centrifugal compressor program.



CD-87-29895

Figure 11. - Performance degradation factors.



CD-87-29896

Figure 12. - Effect of scaling on centrifugal compressor performance.

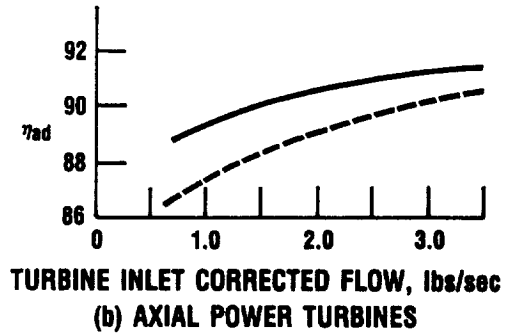
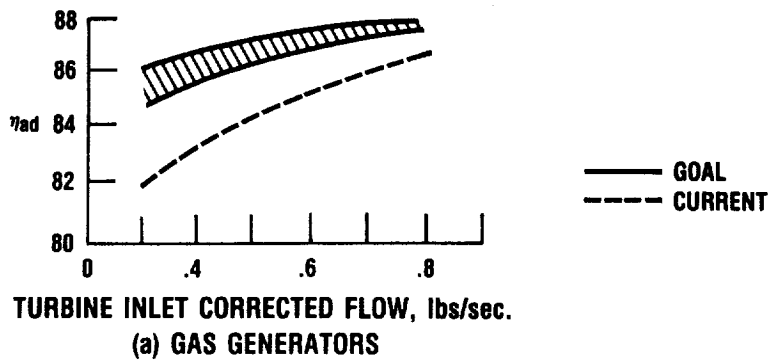

CD-87-29897

Figure 13. - Turbine efficiency.

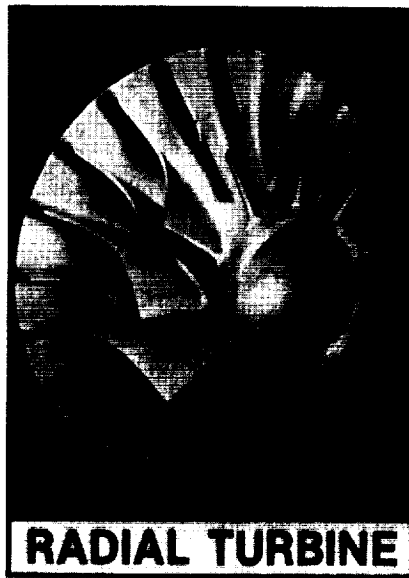

- ENDWALL EFFICIENCY IMPROVEMENT
- LOW ASPECT RATIO AERODYNAMICS
- ENGINE ENVIRONMENT EFFECTS
- SMALL SIZE PENALTIES
- HIGHLY LOADED STAGES
- VARIABLE GEOMETRY
- MANIFOLDS & DUCTS
- COOLING AERODYNAMICS
- VALIDATION OF COMPUTATIONAL METHODS

CD-87-30040

Figure 14. - Small turbine aerodynamics.

- APPLIED, FOR FIRST TIME, A NEW ADVANCED STRUCTURAL ANALYSIS CODE FOR PREDICTION OF FAST FRACTURE FAILURE PROBABILITY OF MONOLITHIC CERAMIC COMPONENTS. THE CODE COMBINES FINITE-ELEMENT STRUCTURAL ANALYSIS CAPABILITY (NASTRAN) WITH WEIBULL STATISTICAL AND FAILURE CRITERIA FROM FRACTURE MECHANICS.

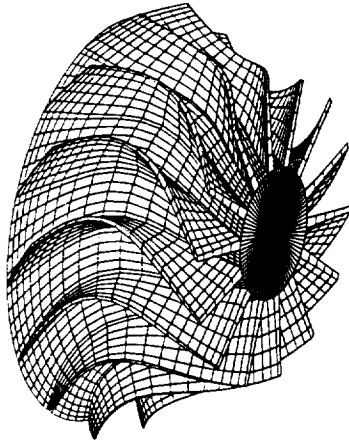

CERAMIC MIXED FLOW TURBINE

CD-87-29987

- COMPLETED THE AERODYNAMIC DESIGN OF HIGH WORK HIGH TEMPERATURE MIXED FLOW TURBINE.
- COMPLETED STRUCTURAL ANALYSIS OF FIRST DESIGN. INDICATED NEED FOR IMPROVED MATERIALS.
- CODE NEEDS FURTHER VALIDATION.

LEWIS IS THE ONLY GOVERNMENT FACILITY WITH AN IN-HOUSE CAPABILITY TO DESIGN CERAMIC COMPONENTS.

Figure 15. - Small turbine engine technology program.

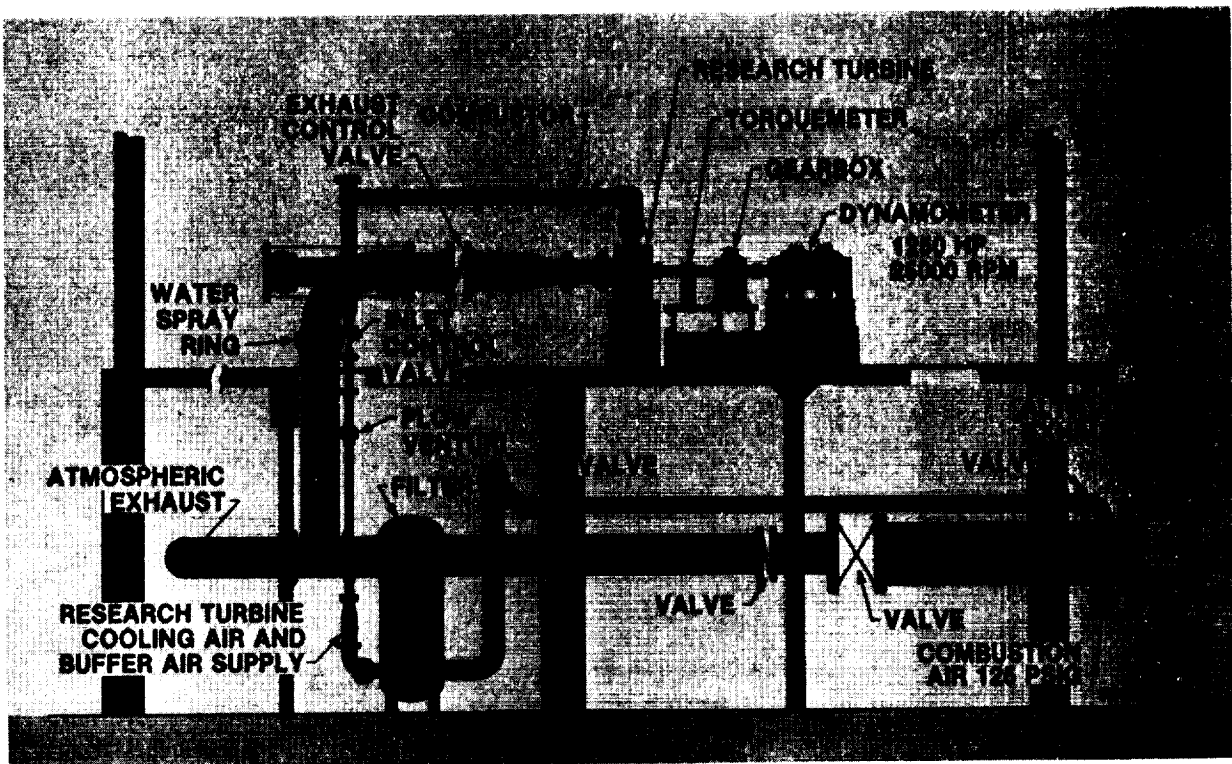

CD-87-29899

Figure 16. - Small Warm Turbine Test Facility.

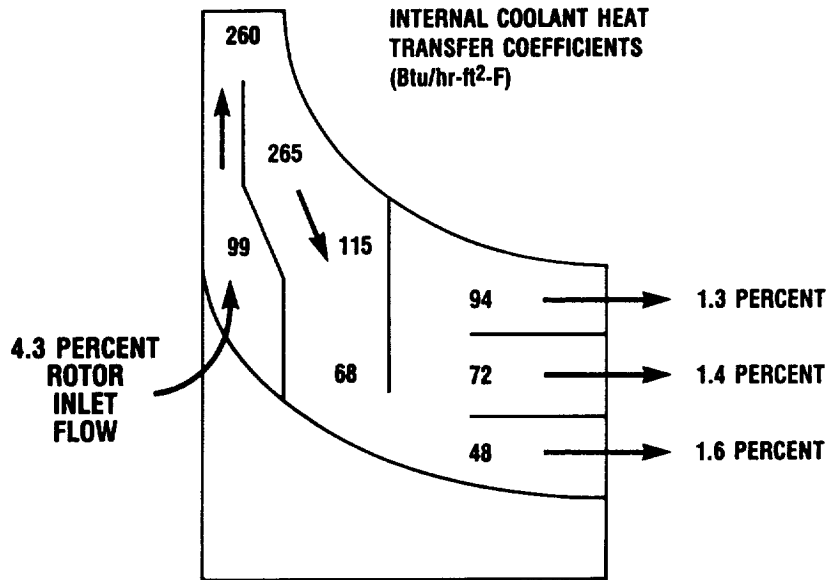

CD-87-29900

Figure 17. - NASA/Allison cooled radial turbine.

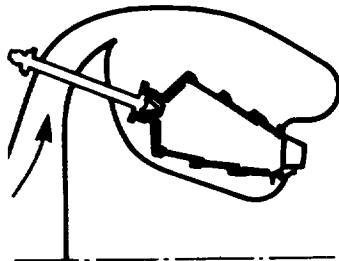

AXIAL FLOW

TECHNOLOGY NEEDS

- **INCREASED TEMP/PRESSURE CAPABILITY**
- **REDUCED AIR COOLANT REQUIREMENTS**
- **INCREASED DURABILITY/RELIABILITY**

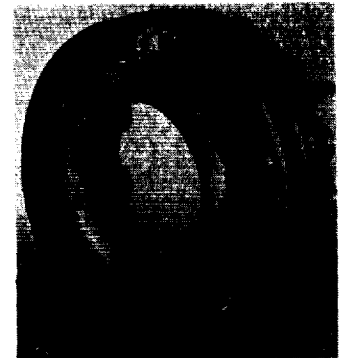

PRIMARY ZONE DESIGN METHODS



ADVANCED LINER COOLING

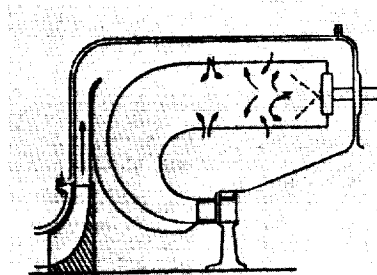

REVERSE FLOW

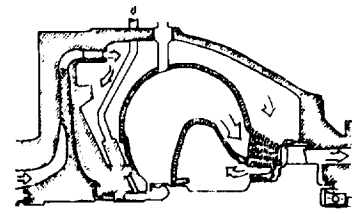

RADIAL OUTFLOW

CD-87-29901

Figure 18. - Small combustor technology.

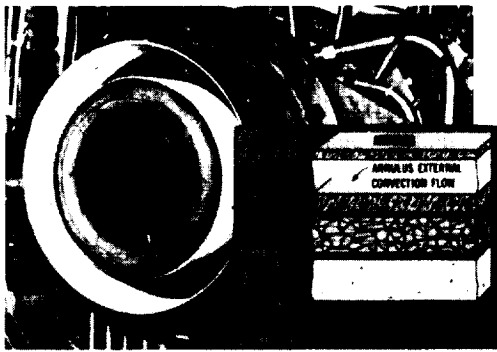

CERAMIC MATRIX BENEFITS

- SIGNIFICANT PERFORMANCE IMPROVEMENTS EXPERIMENTALLY VERIFIED AT ADVANCED CYCLE CONDITIONS—300 °F HOTTER THAN CURRENT ENGINES
- ADDITIONAL COOLANT NOW AVAILABLE FOR OTHER ENGINE USES

CD-87-29902

Figure 19. - Ceramic matrix combustor liner (joint NASA/Army program).

COMBUSTOR LINER COOLING COMPARISON (SIMULATED 16:1 ENGINE CYCLE)

OBJECTIVE: REDUCE COOLING REQUIREMENTS AND EXTEND LINER LIFE AT HIGHER TEMPERATURES THROUGH USE OF CERAMICS

- CERAMIC THERMAL BARRIER-YTTRIA STABILIZED ZIRCONIA WITH COMPLIANT METALLIC BACKING
- METAL SUBSTRATE SUPPORT STRUCTURE
- BACKSIDE CONVECTIVE COOLING ONLY

LINER COMPARISON (CYCLE 16:1)

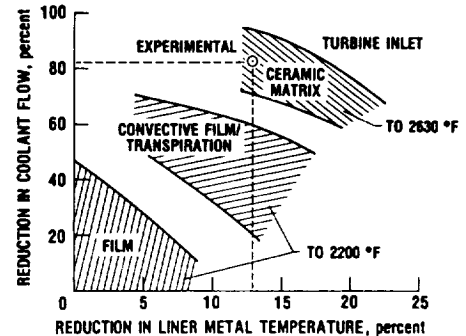

OBJECTIVE:

- DEVELOP A TECHNOLOGY BASE APPLICABLE TO A COMPETITIVE AUTOMOTIVE GAS TURBINE ENGINE

TECHNOLOGY FOCUS:

- HIGH TEMPERATURE CERAMIC COMPONENT TECHNOLOGY

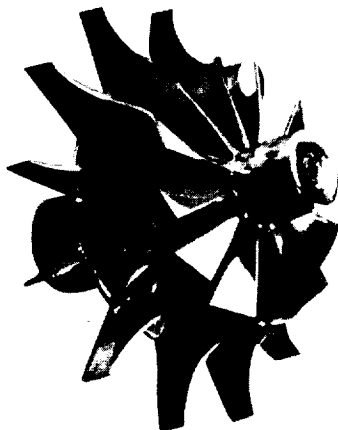
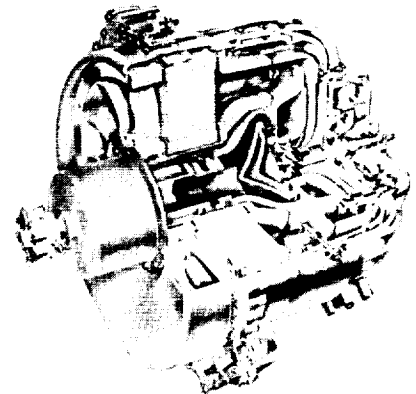

APPROACH:

- DEVELOP IMPROVED
 - ANALYTICAL DESIGN TOOLS
 - COMPONENT FABRICATION PROCESSES
 - PROCEDURES FOR EVALUATING CERAMIC COMPONENTS

CD-87-29903

Figure 20. - DOE/NASA advanced gas turbine technology.

AGT 100 TEST-BED ENGINE

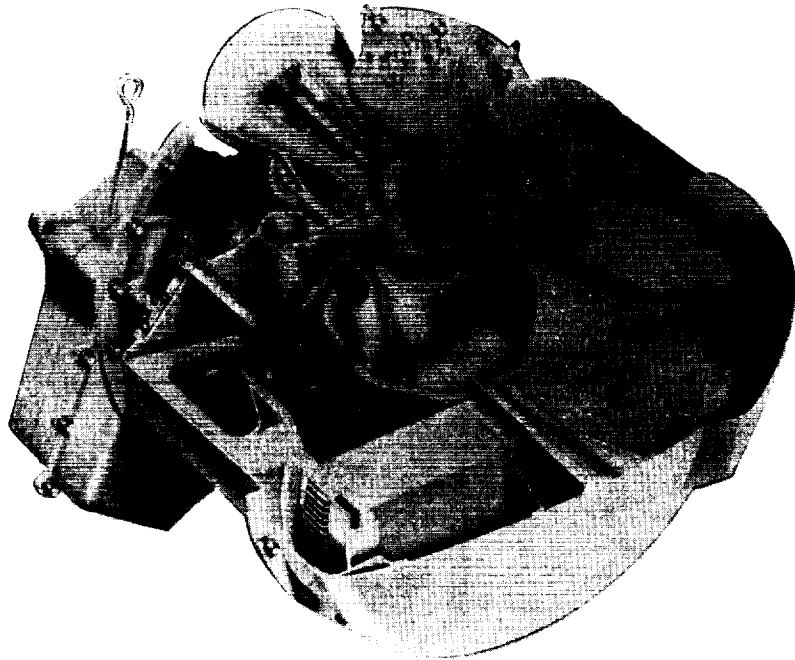

DESCRIPTION

- REGENERATED TWO SHAFT
- TURBINE INLET TEMPERATURES UP TO 2350 °F
- MAXIMUM ROTOR SPEED 86,000 RPM

CD-87-29904

Figure 21. - DOE/NASA advanced gas turbine ceramic component technology.

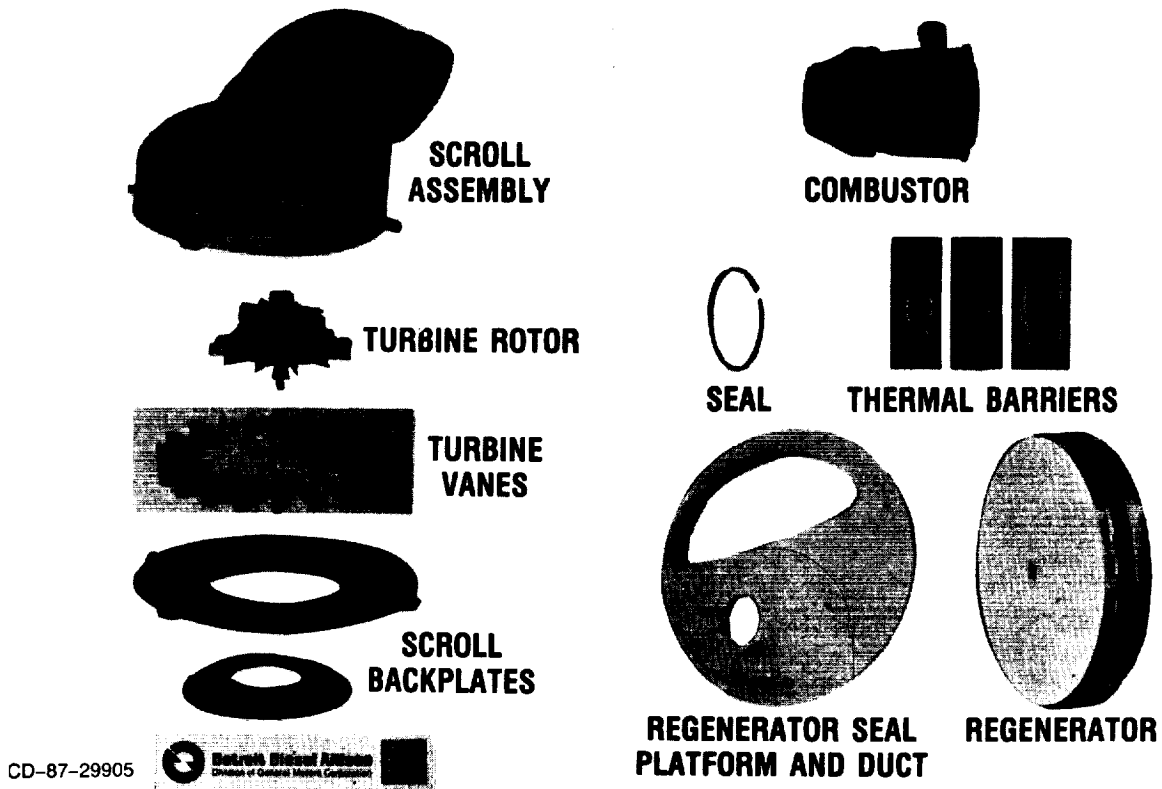
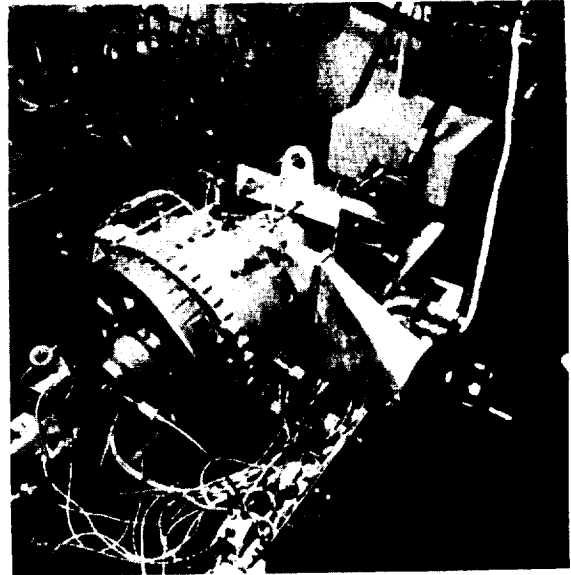

Figure 22. - AGT 100 ceramic components.

- **TURBINE INLET TEMPERATURE:
2000-2200 °F**
- **OPERATING SPEED:
60,000-70,000 RPM**
- **STARTS: 5**
- **SAME STRUCTURES FROM
PREVIOUS TEST**
- **TEST STOPPED DUE TO
TURBINE ROTOR DAMAGE**



CD-87-29906

Figure 23. - All-ceramic engine operated for 85 hr at 2200 °F.

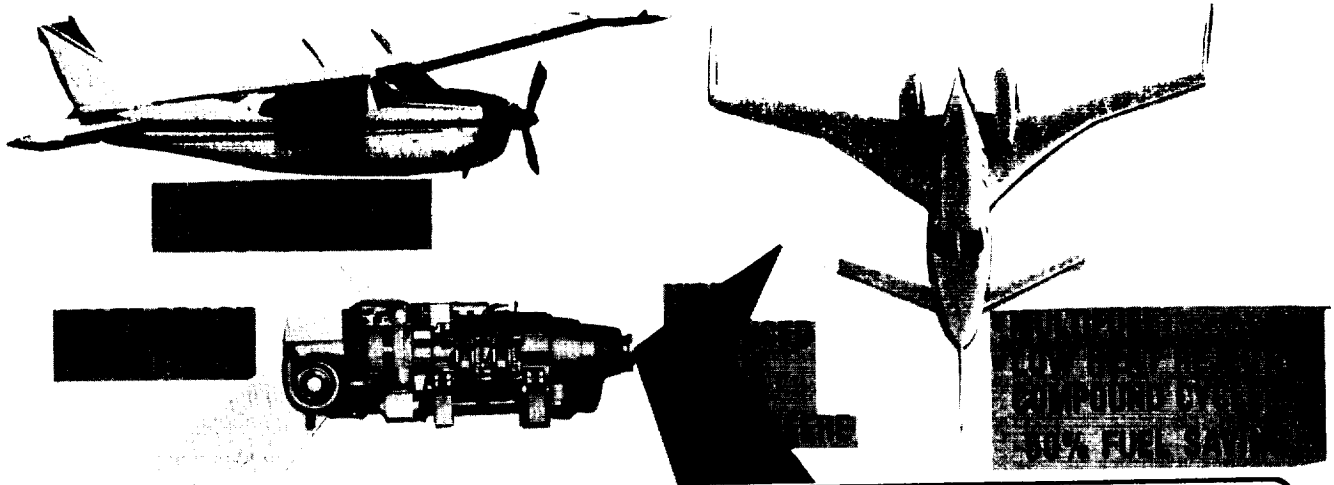

**NASA-INDUSTRY
TECHNOLOGY
INVESTMENT**

PAST AND CURRENT

FUNDAMENTAL R & T

- COMBUSTION, THERMAL, MECHANICAL MODELS
- VALIDATION OF CODES
- LOW HEAT REJECTION TECHNOLOGY
- TRIBOLOGY AND TURBOCOMPOUNDING

TECHNOLOGY ASSESSMENT

- ADVANCED COMPONENT AND SYSTEMS TESTS

CD-87-29908

Figure 24. - Rotary engines.

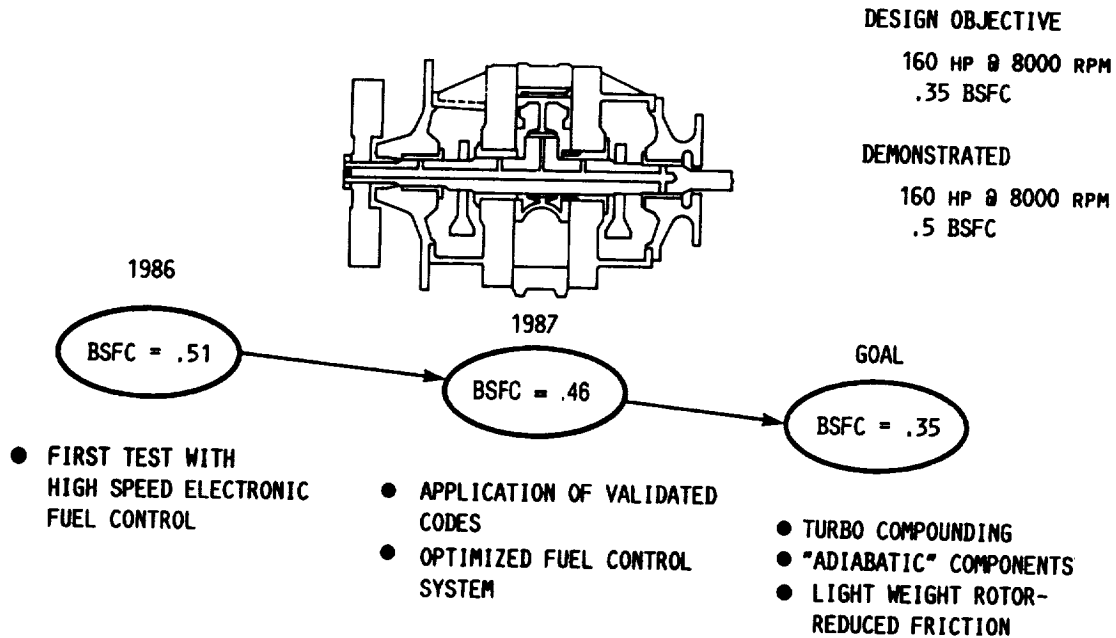

CD-87-29909

Figure 25. - NASA/Deere stratified-charge rotary engine.

OBJECTIVE: ENLARGE DIESEL TECHNOLOGY BASE FOR WIDE RANGE OF AIR AND LAND VEHICLE APPLICATIONS

SIZE RANGE: 500 TO 2000 HP

APPROACH:

- FOCUS ON HIGH SPEED AND HIGH PRESSURE TO REDUCE SIZE
- RESUME PREVIOUS DARPA-SPONSORED PROGRAM WITH GARRETT
- BROADEN PROGRAM TO INCLUDE MORE OF ENGINE INDUSTRY
- ESTABLISH BASE FOR DEMONSTRATOR

EXPECTED RESULT:

- FUEL SAVINGS OF 40 PERCENT
- COMPACT, COMPOUND CYCLE
- BROAD APPLICATIONS



HELICOPTER
FIXED WING/PROPELLOR
TILT ROTOR

HIGH MOBILITY VEHICLE
LANDING CRAFT
AIR CUSHIONED VEHICLE

CD-87-29910

Figure 26. - Compound Cycle Engine program.

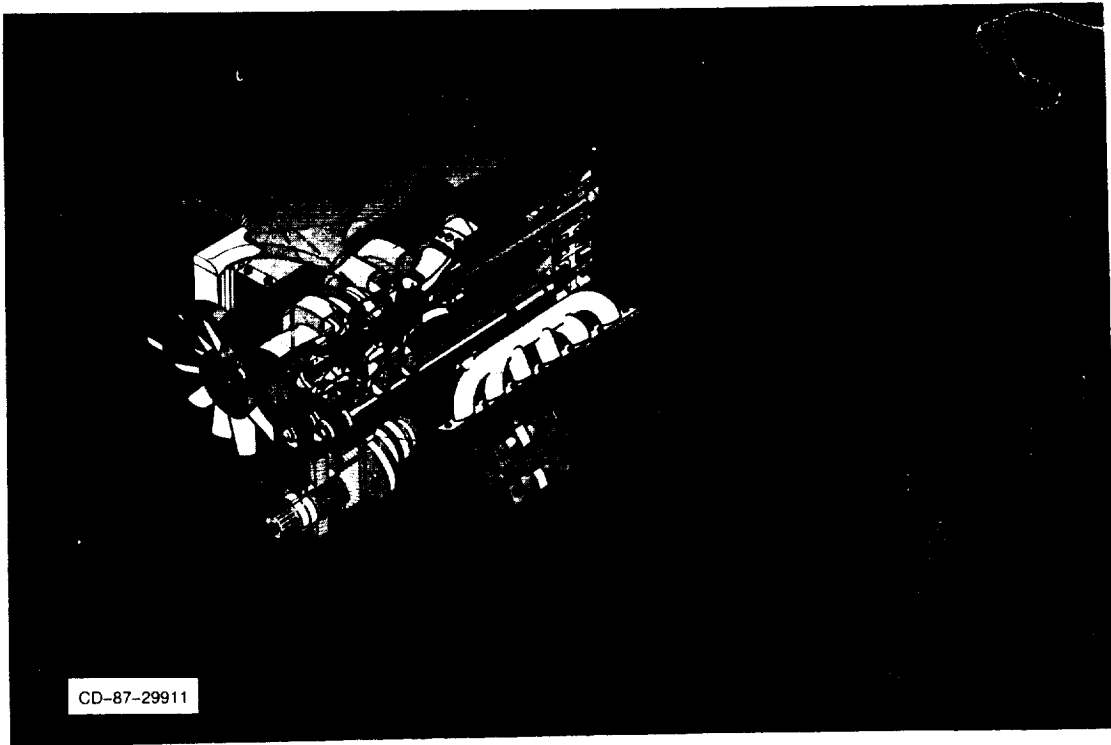

CD-87-29911

Figure 27. - Compound cycle engine.

OBJECTIVE:

**DEVELOP A TECHNOLOGY BASE APPLICABLE TO THE
ADVANCED "ADIABATIC" DIESEL ENGINE OF THE FUTURE**

GOALS:

FUEL ECONOMY

**30% IMPROVEMENT OVER CONVENTIONAL
DIESEL ENGINES**

ECONOMIC & SOCIAL ACCEPTANCE

**COMPETITIVE CAPITAL & MAINTENANCE COSTS
MEET NOISE & EMISSIONS STANDARDS
FUEL TOLERANCE**

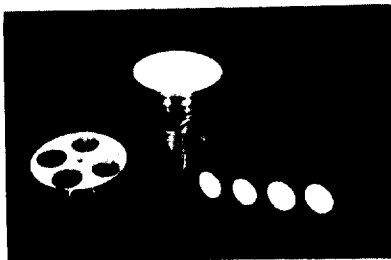
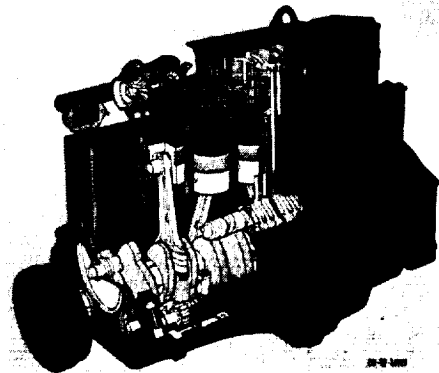

APPROACH:

**ELIMINATE WATER COOLING
CERAMIC INSULATING MATERIALS
HIGH TEMPERATURE TRIBOLOGY
WEAR COATINGS, PISTON SEALS, LUBRICATION
EXHAUST GAS HEAT RECOVERY
ADVANCED TURBOCOMPOUND, BOTTOMING CYCLE**

CD-87-29912

Figure 28. - DOE/NASA Heavy Duty Transport Technology Project.

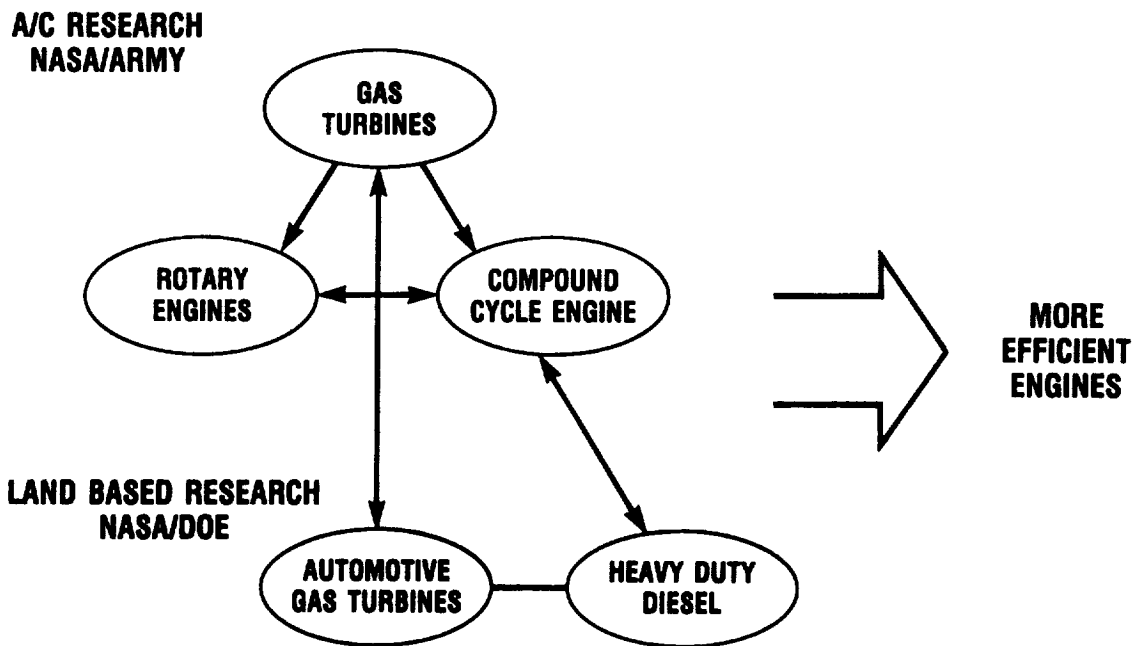

Figure 29. - Small engine research summary.

CD-87-29915