

N 9 2 - 2 2 7 2 3

**COMMERCIAL "CAPACIFLECTOR"**

John M. Vranish  
NASA/Goddard Space Flight Center  
Greenbelt, Maryland 20771

**ABSTRACT**

A capacitive proximity/tactile sensor with unique performance capabilities ("Capaciflector" or capacitive reflector) is being developed by NASA/GSFC for use on robots and payloads in space in the interests of safety, efficiency, and ease of operation. Specifically, this sensor will permit robots and their attached payloads to avoid collisions in space with humans and other objects and to dock these payloads in a cluttered environment. The sensor is simple, robust, and inexpensive to manufacture with obvious and recognized commercial possibilities. Accordingly, NASA/GSFC, in conjunction with industry, is embarking on an effort to "spin" this technology off into the private sector. This effort includes prototypes aimed at commercial applications. The principles of operation of these prototypes are described along with hardware, software, modelling, and test results. The hardware description includes both the physical sensor in terms of a flexible printed circuit board and the electronic circuitry. The software description will include filtering and detection techniques. The modelling will involve finite element electric field analysis and will underline techniques used for design optimization.

**INTRODUCTION**

The objective for NASA purposes is to develop a proximity sensing skin that will permit a robot to sense intruding objects without blind spots (up to one foot). This is a multi-purpose sensor. When used as an array on its arms, the robot can be prevented from colliding with an object in space, particularly a human being. When sensing skin elements are placed on an Orbital Replacement Unit (ORU), these units can be manipulated, berthed and fastened down with unprecedented accuracy and safety-no possibility of unwanted collisions. NASA research has also demonstrated that scanning the sensor can produce clear images and that the near range resolution is so accurate that precontact virtual force control is possible. The sensor is capable of becoming central to NASA space robot control.

This sensing skin must be able to function reliably in the extreme environment of space and not disturb or be disturbed by neighboring NASA instruments. It should be simple, compact and be incidental to the robot design. An approach based on an array of capacitors appears promising in solving both the proximity and tactile models [1]. However, the system must be able to detect objects (including humans) at ranges in excess of one foot so that the robot can react. To obtain such a range, a capacitive sensor typically must be "stood off" from the grounded robot arm a considerable distance (approximately one inch). This would disfigure the robot arm, causing it to be bulkier than necessary. It would also make cross-talk between the sensor elements more pronounced and would likely impede the flow of heat from the robot arms to outer space (a serious problem for the Flight Telerobotic Servicer (FTS)). The "Capaciflector" (capacitive reflector) described in this paper solves these problems and, in so doing, advances the state-of-the-art in capacitive sensor performance.

NASA is now in the process of developing a commercial version of the "Capaciflector", 2.5 cm (1 in.) on a side. This sensor will be ultra simple, inexpensive and compact (essentially a piece of flexible printed circuit board with electronic circuitry mounted on its reverse side). But, with ranges in excess of 13 cm (5 in.) vs 2.5 cm (1 in.) for comparably-sized commercially available capacitive sensors, the commercial "Capaciflector" will use both an analog output (signifying range) and an on/off switching signal that can be reset as required.

## THE "CAPICIFLECTOR"

The "Capaciflector" is a capacitive sensing element backed by a reflector element which is driven by the same voltage as the sensor to reflect all field lines away from the grounded robot arm, thus extending the range of the sensor. This approach is an extension of the technique used in instrumentation systems where a shield or guard is used to eliminate stray capacitance [2].

Fig. 1 shows the principles of operation in terms of charges and electric fields. Fig. 1a shows a capacitive sensor not using the "capaciflector" principle. Since we are using relatively low frequencies (approximately 20 kHz) we have the quasi-static condition and static charges and electric fields can be used to determine the capacitance the sensor "sees". We can see that the smaller the stand-off from the grounded robot arm, the larger the capacitive coupling between the sensor and ground. This, of course, has the effect of reducing the relative coupling between the sensor and the object being sensed and hence reducing sensor range and sensitivity. On the other hand, increasing the stand-off increases the bulk of the robot arm and adds wires and wiring complications. And, when the insulation materials are added to support the stand-off, the ability of the robot arm to dissipate thermal energy into space is impeded. When the "capaciflector" principle is used (Fig. 1b)[3], the field lines from the sensor are prevented from returning directly to ground. The effective stand-off is approximately the width of the active shield or capacitive reflector. Thus, we can have a skin with very little thickness (on the order of 0.060 inches) and a robot arm with very little bulk and still have the performance of a large stand-off. Fig. 2 shows the electronic circuitry. The capacitive coupling between the sensor and the object being sensed is used as the input capacitance tuning the oscillator frequency. As an object comes closer, the capacitance increases and the oscillator frequency decreases. On the other hand, the reflector is attached to the output of the voltage follower so it is electrically isolated and prevented from affecting the tuning of the oscillator frequency. At the same time, the voltage of the reflector follows that of the oscillator. Thus, the reflector is in phase with (and reflects) the electric field of the sensor without being affected by the coupling between the sensor and an approaching object.

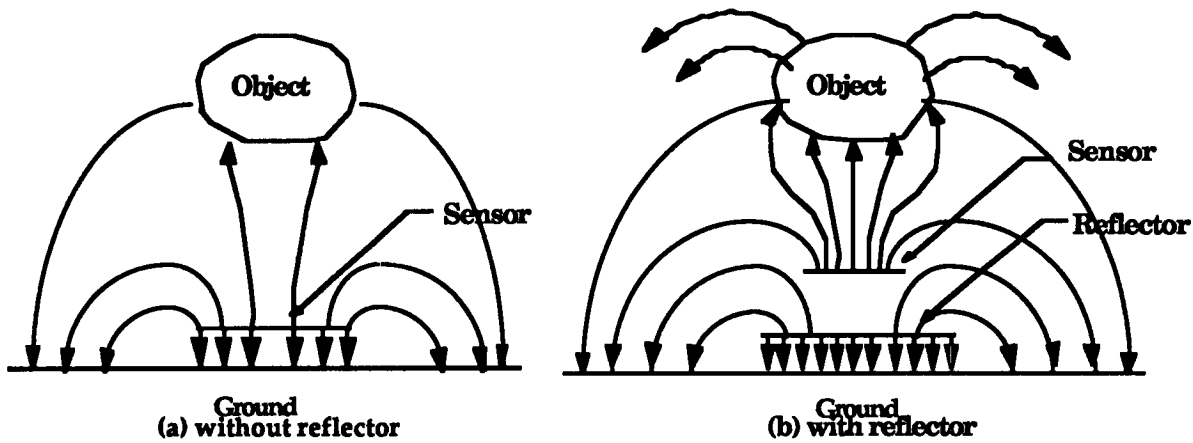

Fig. 1 : "Capaciflector" principle[3]

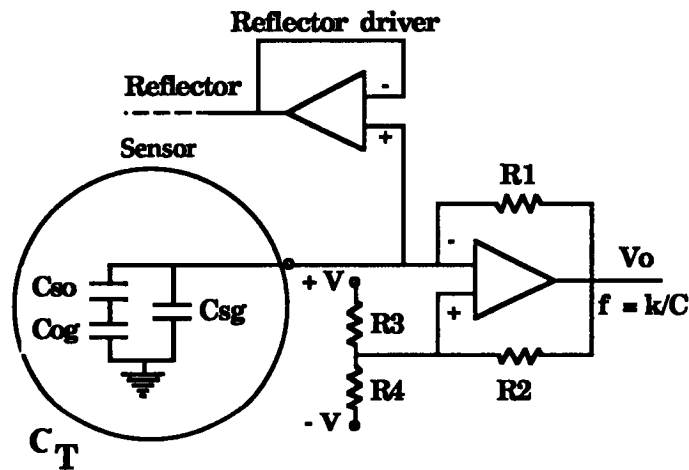

Fig. 2 : "Capaciflector" circuitry[3]

#### DETECTION

We will now examine the means by which the sensor detects an object[3]. The discussion will be limited to conductors for simplicity although dielectrics are also easily detected. Both the grounded and ungrounded (Fig.1) cases will be examined. Since we have low frequency, (approximately 20 kHz), the quasi-static case holds. Assuming a momentary positive potential  $V$  in Fig. 1b. we can see that the electric field lines emanating from the sensor towards the object induce negative charges on the object surface nearest the sensor. Thus that surface can be considered one plate of a capacitor and the sensor the other. But, an ungrounded conductive object is charge neutral so an equal amount of positive charge will form on the surface away from the sensor so as to ensure that there is no net electric field in the conductor. These charges couple back to ground which creates a second capacitor in series with the one mentioned above. These are labeled in Fig. 2 respectively as:

$C_{so}$  and  $C_{og}$

But; there also is a path where the electric fields from the sensor can go around the active shield and couple to ground directly. This is labeled as:

$C_{sg}$

Thus our tuning capacitance is:

$$\frac{C_{so} C_{og}}{C_{so} + C_{og}} + C_{sg} = C_t \quad (1)$$

In the case where the object is grounded, equation (1) reduces to:

$$C_t = C_{sg} + C_{so} \quad (2)$$

Examining equations (1) and (2) above, since we are looking for small changes in  $C_t$  it is clear we want  $C_{sg}$  to be small. Therefore, we want the shield or reflector to force the field lines from the sensor towards the object as much as possible.

We now turn to the case where the object is not grounded [4,5,6]. We know:

$$C = \frac{Q}{V} \quad (4)$$

We also know that a good conductor must have the same potential everywhere on its surface. Therefore the potential on the object will be that of its furthest point from the sensor. we will call the potential on the sensor  $V$  and the object potential  $V_o$ . Thus we have:

$$\frac{Q_i}{V - V_o} = C_{so} \text{ and } \frac{Q_i}{V_o} = C_{og} \quad (5)$$

where

$Q_i$  = charge induced in the object.

It is apparent that an object with any dimension more than a few inches in any direction (for example length) forces the potential on the entire surface of the object to be very low. And, as the experimental evidence shows, in practice, all objects are approximately grounded.

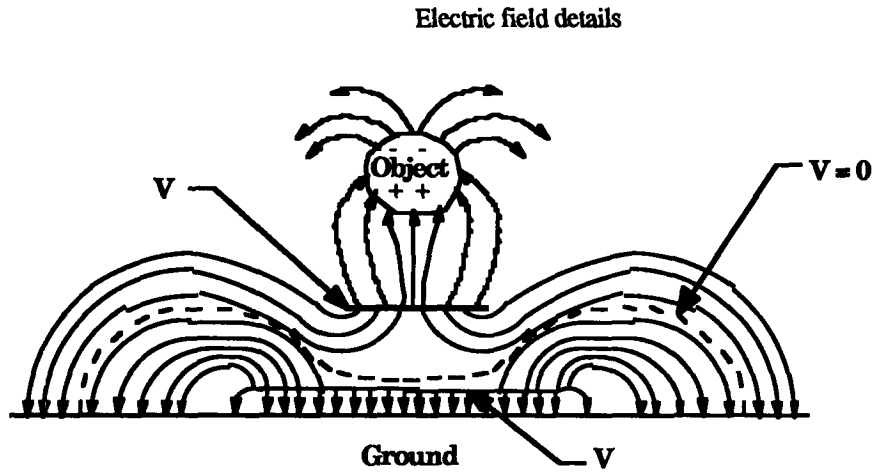

Fig. 3 : Electric field details [3]

### MODELING

In order to verify the experimental results, and to further improve the sensor, a static electric field model was developed. The objective was to determine the percentage change in frequency of the oscillator resulting from the introduction of an object within the field of the capaciflector. The frequency of oscillation of the circuit in Figure 2 can be shown to be

$$f = \frac{\ln 0.5}{2R_1C}$$

Where:  $R_3 = R_4 = 2R_2$

This implies

$$\frac{\Delta f}{f_0} = \frac{\Delta C_t}{C_{t0} + \Delta C_t}$$

where  $f_0$  and  $C_{t0}$  represent the frequency and the capacitance of the sensor in the absence of an object, and  $\Delta f$  and  $\Delta C_t$  represent the change in frequency and capacitance respectively because of the introduction of an object.

The method of moments approach was chosen to determine the capacitances, as it allows one to model systems with no boundaries. The modeling approach is therefore similar to that used by Volakis et al. [7]. In our case, the system consists of the grounded robot arm, the sensor shield, the sensor, and the detected object. The system is approximated by a two dimensional model — we solve the problem for a cross section of the system assuming that the system extends to infinity along the axis perpendicular to the plane.

In this method, after discretizing the two dimensional system entities, each discrete element of length  $\Delta s$  with a charge density of  $\rho$ , is approximated to a point charge of magnitude  $\rho \Delta s$ , located at the center of mass of the element. The charge densities are then determined by solving the following set of  $M$  linear equations,  $M$  being the total number of elements in the system.

$$\sum_{m=1}^M \rho_m K_{nm} = V_n - V_k; n = 1, 2, \dots, M, n \neq k$$

$$\sum_{m=1}^M \Delta s_m \rho_m = 0$$

where  $V$  is the voltage of an element,  $K_{nm}$  is the integral of the two dimensional Green's function for statics, and  $k$  reference element.  $K_{nm}$  is given by the following relations [Ibid]:

$$K_{nm} = \Delta s_m \ln(r_{nk} / r_{nm}) / 2\pi\epsilon; m \neq n, n \neq k$$

$$K_{nm} = \Delta s_m [\ln(r_{nk} / \Delta s_m) + \Delta s_m (1 + \ln 2)] / 2\pi\epsilon; m = n$$

where  $\epsilon$  is the permittivity of the medium and  $r_{ij}$  is the distance between the  $i$ th and the  $j$ th elements (point charges).

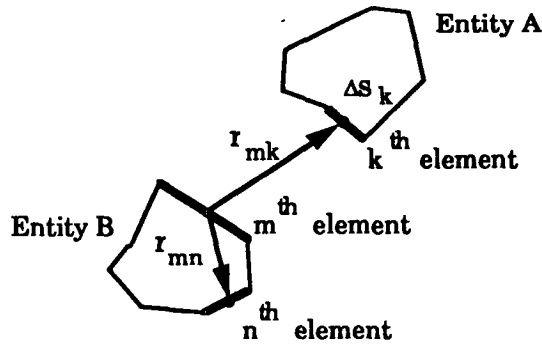

Fig. 4: Description of the variables used in the method of moments

The sensor capacitance is then determined by summing the capacitances of the elements representing the sensor:

$$C_s = \sum_{m=1}^N \Delta s_m \rho_{s_m} / (V_{s_m} - V_k); \rho_{s_m} > 0$$

where  $N$  is the total number of elements representing the sensor.

A computer program was written to calculate the total capacitance seen by the sensor for several configurations. For each configuration, the program moves a circular object on a grid placed on the plane of the entities, and the sensor capacitance is computed for each object position. One of the outputs the program provides is a data file for drawing the frequency change vs distance plots for each such configuration.

The program was used to plot graphs for the four configurations shown in Fig. 5 which were tested in the laboratory, and the results are shown in Fig. 6. The abscissa represents the distance of the object from the sensor, and the ordinate the percentage change in frequency. The center of the object is above the center of the sensor for the

cases shown.

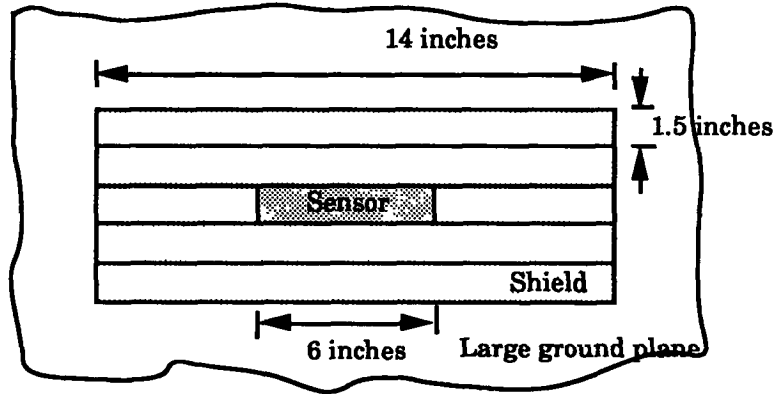

**Fig. 5a : Test sensor**

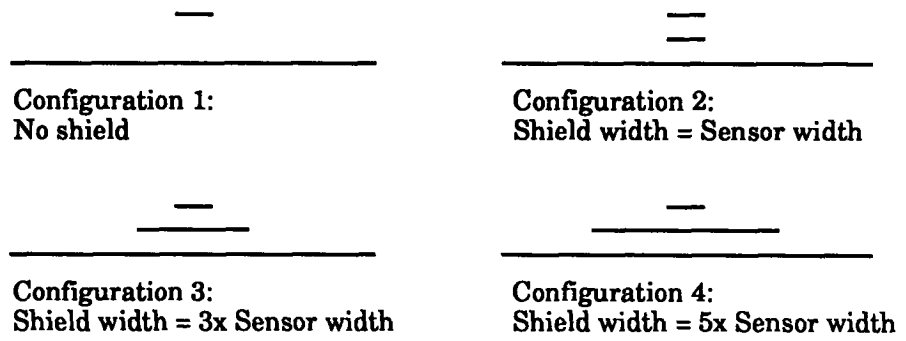

**Fig. 5b: Sensor/Shield configuration**

**Fig. 5: Test configurations [3]**

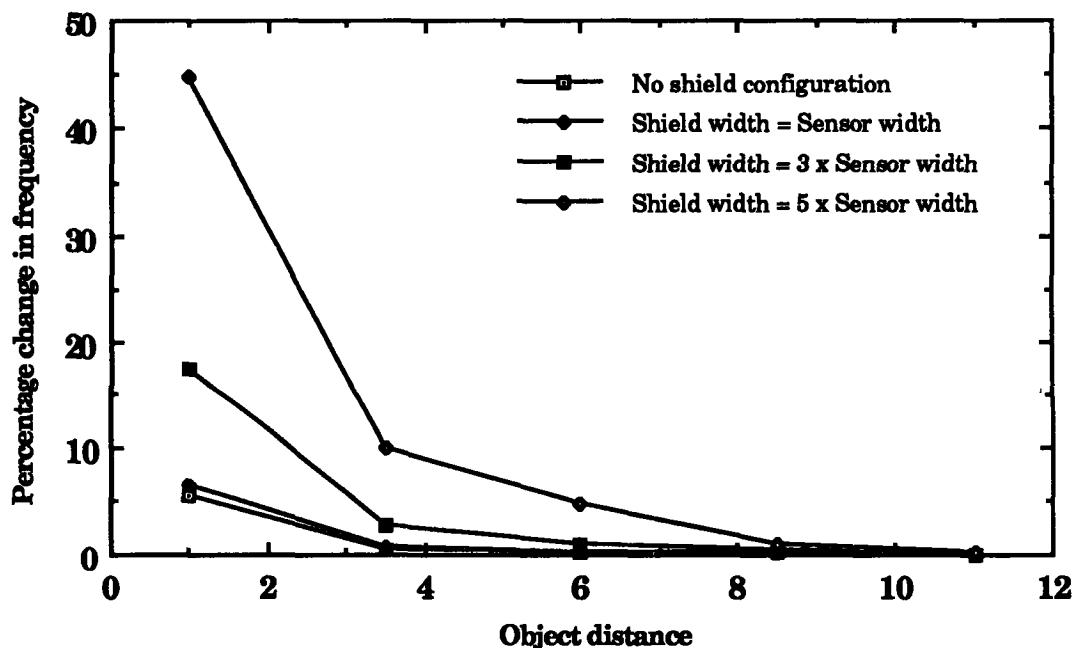

Fig.

Modeling results, [3]

% Frequency Change vs Object Distance From Sensor.

#### EXPERIMENTAL RESULTS

An experimental laboratory set-up was assembled and a similar set of sensor configurations and object positions measurements were taken. The results of the experiment are shown in Fig. 7 and are similar to the model results. Since the computer model only simulates a two dimensional configuration, the results of the simulation assume infinitely long strips of the sensor, reflector, and object. The experimental set-ups were similar; the sensors was approximately six inches long, the reflector approximately fourteen inches long, and the object one inch in diameter and thirty six inches long. The reflector was made from strips of copper foil that could be connected in the configurations shown in Figure 5b. Subsequent testing has shown that the sensor must be shorter than the reflector to reduce end effects which substantially reduce sensitivity. The explanation is that the reflector must totally surround the sensor to contain the field. Otherwise, the flux lines from the sensor will simply shift to the lower field strength and return to the ground at the ends of the sensor, thereby reducing the coupling to the object.



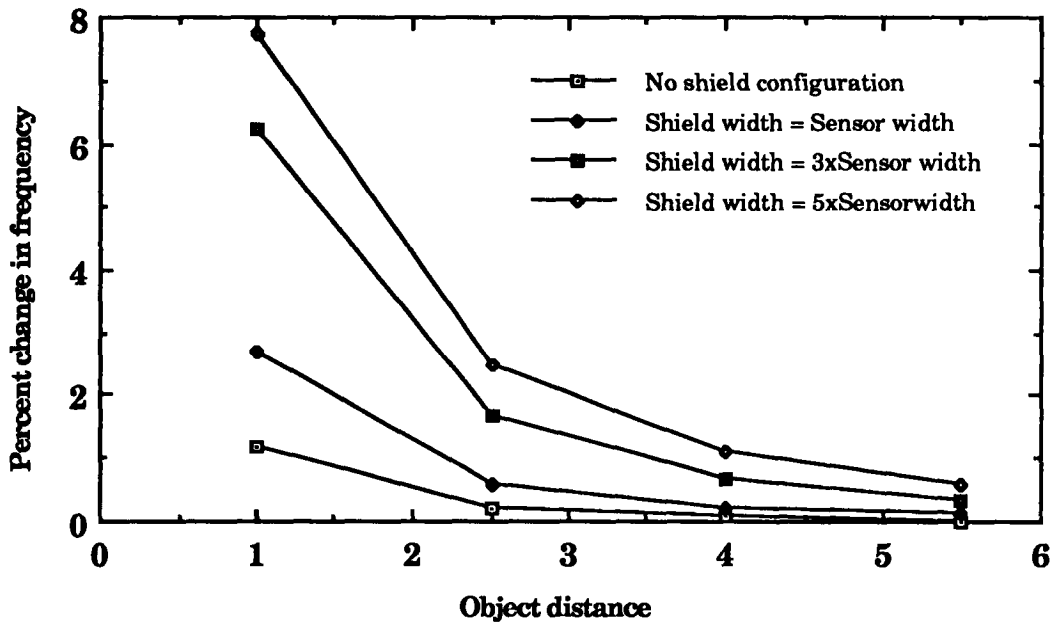

Fig. 7

### Experimental results [3]

#### DISCUSSION OF RESULTS

The results from the modeling and the experiment are similar. Both show the frequency change is inversely proportional to the object distance distance from the sensor. They both show that the sensitivity increases dramatically as the the shield width increases. The increase is approximately 7-fold for the experimental result and almost 9-fold for the model.

The substantial difference shown between the modeled results and the experimental results are probably due to our primitive models used to date. The model program assumes infinitely long strips for the sensor, shield, and object, while our experiment used a 6 inch sensor with 14 inch shield. End effects or the short sensor may account for the difference; our modeling has not progressed far enough to determine. The rate of variation between the curves is also different. The model shows almost no difference between the curves for no shield and shield=sensor width, while the experimental results show a substantial difference. This result may be entirely due to inaccuracies in the model. Similarly, there is a difference between the rate of change between the upper two curves on the graphs. The model shows an increasing rate of change difference while the experimental result shows almost a constant difference. We cannot presently account for this result, but it may be due to either the model or to electronic circuit limitations. This latter conjecture comes from the fact that the frequency changes are substantial and nonlinearities may limit the frequency shift. Investigations are continuing.

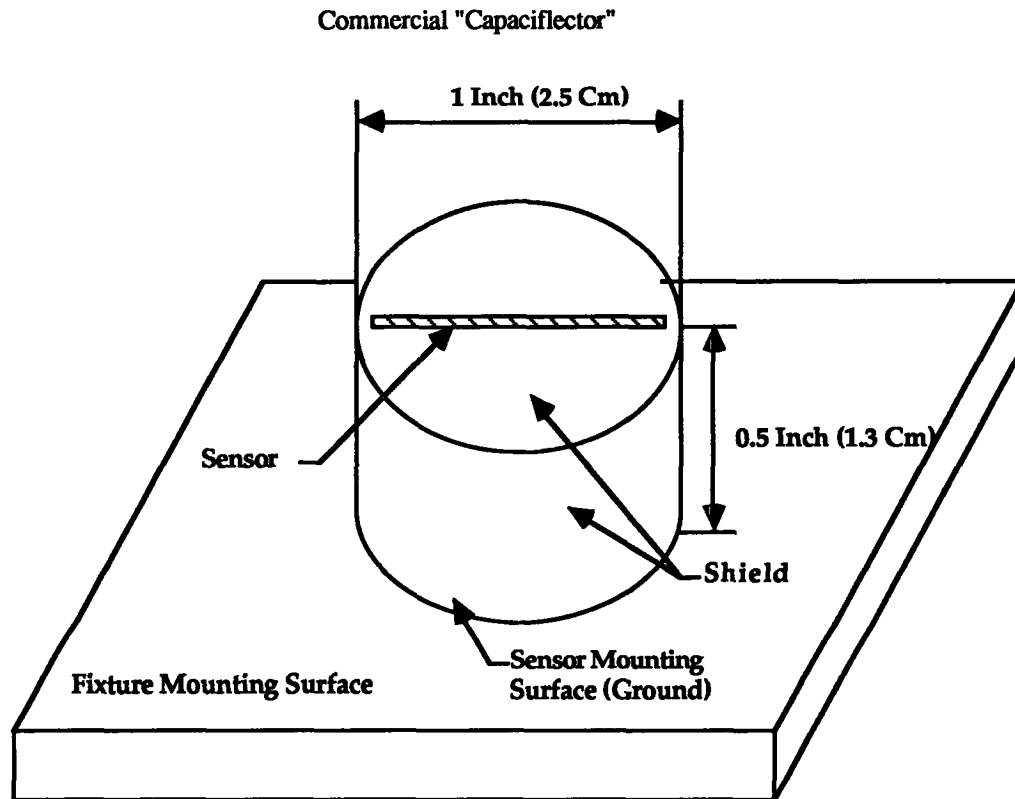

**Fig. 8: Commercial "Capaciflector"**

The commercial "Capaciflector" (Fig. 8) should be as small as possible so that it can be placed in grounded, confined areas, the typical situation in industrial applications. Thus, its reflective shield will be smaller than that of the NASA space version and, accordingly, the range and sensitivity/dynamic range will be compromised. For a sensor 1 in. dia and 0.50 in thick, we have measured a range of 7 in. when mounted on an insulator, 5 in. when mounted on a conductor. This is still 5 to 7 times the range and sensitivity achieved by commercially available capacitive sensors in a package 1/2 the volume (to include the sensor head and electronics-signal amplification and filtering). Thus, we have a significant increase in performance. In addition, the cost of fabrication will be much reduced. The sensor head and input/output leads is essentially a flexible printed circuit board. The electronics is ultra simple and straight forward and will be attached to the reverse side of the sensor.

With such an increase in performance, it seems sensible to have an analog signal which measures range in addition to the customary on/off switching output. Furthermore, the switching output will be electronically adjustable so that the sensor can be calibrated at the worksite, in real time, to respond to any of several object shapes and materials at any of several ranges.

These features will permit the sensor to have unprecedented performance and flexibility. It will be able to be used in the classic sense as a switching noncontact sensor. And, in this role, it will have a marked advantage over existing sensors with a greater range and superior signal to noise ratio in that range. Or alternately, it can provide a crisper, more certain switching point at a less than maximum range to include a crisper detection of edges. And, with the

electronically adjustable switching output, it will be able to be calibrated against a given object of a given material, at a given range in real time. This will result in extraordinary operational flexibility, as well. It can be used to determine range, which is also unprecedented for industrial-type capacitive (or inductive) sensors. And, with the superior range available, close-in range determination now becomes practical. This, in turn, suggests an entire new dimension in adaptive control for automated techniques in robots and machine tools. For example, automated, machine contour following will become practical. Also, robots and machine tools will be able to slow down just before contacting an object, switch from position control to force control mode before contact and thereby minimize the shock inherent in contacting the object and the instabilities that attend. This will also minimize the need for passive compliance; add-on solutions that have been used in the past.

#### SUMMARY

The NASA "Capaciflector" is well on its way towards becoming a central part of collision avoidance, docking and berthing and pre-contact force control in space and will be used extensively on robot arms, robot end effectors and payloads. It will also likely find uses inside robot mechanisms in support of their controllers. Thus GSFC has a large and growing in-house capability regards this sensor and this capability can easily be applied to the Commercial "Capaciflector".

## REFERENCES

1. Vranish, John M. and Durg S. Chauhan, "*Tri-Mode Collision Avoidance Skin for Robot Arms in Space*", Proc. Third International Symposium on Robotics and Manufacturing, 1990.
2. Webster, John G. , "*Tactile Sensors for Robotics and Medicine*", John Wiley & Sons, Inc., Copyright 1988, pp. 209,202.
3. Vranish, John. M., McConnell, R. L., Mahalingam, S., *The International Journal of Computers and Electrical Engineering*, ["*Capaciflector*" Collision Avoidance Sensors for Robots] to be published.
4. Hayt, William H. Jr., "*Engineering Electromagnetics*" , McGraw-Hill, Inc., Copyright 1981, 1974, 1967, 1958, p.146.
5. Lorrain, Paul, Corson, Dale R. and Lorrain, Francois, "*Electromagnetic Fields and Waves*", W.H. Freeman and Co., Copyright 1988, pp.108-116.
6. Fischer, C. R. "*Build the Digital Theramin*", 1989 PE HOBBYISTS HANDBOOK, pp. 142,143,144,152.
7. Volakis, J.L., et al. "*Mapping of electrostatic fields using the IBM personal computer*", IEEE Transactions on Education, Vol E-30, No. 4, Nov 1987, pp 247-250.

---

---

## **ENVIRONMENTAL TECHNOLOGY**

**(Session E4/Room C1)**

**Thursday December 5, 1991**

- **Water Quality Monitor**
- **Remote Semi-Continuous Flowrate Logging Seepage Meter**
- **Calcification Prevention Tablets**
- **Automated Carbon Dioxide Cleaning System**