

NASA CASE NO. MFS-28430-1

TECHNICAL ABSTRACT

### Prosthetic Helping Hand

A prosthetic device for below-the-elbow amputees having a C-shaped clamping mechanism for grasping cylindrical objects. The clamping mechanism is pivotally mounted to a cuff that fits on the amputee's lower arm.

Referring to Figure 2 of the patent application, the prosthetic helping hand comprises a cuff (10), an anchor (20), a spring (30), a ball (40) and socket (50), and a clamping mechanism (60).

The present invention is utilized by placing an arm that has been amputated below the elbow into the cuff. The clamping mechanism then serves as a hand whenever it becomes necessary for the amputee to grasp a cylindrical object 70 such as a handle, a bar, a rod, etc. To grasp the cylindrical object, the object is jammed against the opening in the C-shaped spring causing the spring to open, the object to pass to the center of the spring, and the spring to snap shut behind the object (see Figure 3). Various sizes of clamping mechanisms can be provided and easily interchanged to accommodate a variety of diameters. Because the extension 41 pivots and rotates, the clamping mechanism can be used in a variety of orientations. Thus, this invention provides a below-the-elbow amputee with a clamping mechanism which can be used to perform a number of tasks.

Inventors: Thomas W. Vest, MSI  
James R. Carden, NASA/MSFC (Ret.)  
William E. Norton, NASA/MSFC  
Jewell G. Belcher, NASA. MSFC

Date Filed: 02/07/92

Serial Number: 07/832,569

(NASA-Case-MFS-28430-1) PROSTHETIC HELPING N92-24044  
HAND Patent Application (NASA) 12 p  
CSCL 06C

Unclas  
G3/54 0087676

P. 12

P. 12

NASA CASE NO. MFS-28430-1  
PRINT FIG. #2

NOTICE

The invention disclosed in this document resulted from research in aeronautical and space activities performed under programs of the National Aeronautics and Space Administration. The invention is owned by NASA and is, therefore, available for licensing in accordance with the NASA Patent Licensing Regulation (14 Code of Federal Regulations 1245.2).

To encourage commercial utilization of NASA-owned inventions, it is NASA policy to grant licenses to commercial concerns. Although NASA encourages nonexclusive licensing to promote competition and achieve the widest possible utilization, NASA will consider the granting of a limited exclusive license, pursuant to the NASA Patent Licensing Regulations, when such a license will provide the necessary incentive to the licensee to achieve early practical application of the invention.

Address inquiries and all applications for license for this invention to NASA/Marshall Space Flight Center, Patent Counsel, Mail Code CC01, Marshall Space Flight Center, AL 35812. Approved NASA forms for application for nonexclusive or exclusive license are available from the above address.

Serial Number 07/832,569  
Filing Date February 7, 1992  
NASA/MSFC

**APPLICATION FOR PATENT**

Title: Prosthetic Helping Hand

NASA Case No. MFS-28430-1

The invention described in this patent application was made in  
05 part by employees of the United States Government and may be  
manufactured and used by or for the Government for governmental  
purposes without the payment of any royalties.

**BACKGROUND OF THE INVENTION**

Field of the Invention: This invention relates to a prosthetic  
10 device. Specifically, the present invention pertains to a  
prosthetic helping hand for use by below-the-elbow amputees.

Background Information: Prosthetic devices used to assist  
people who have received a below-the-elbow arm amputation  
generally fall into two categories: bionic devices and  
15 body-powered devices. The body-powered devices seem to be the  
most preferred alternative. Many of the current artificial  
limbs have disadvantages which consist of being (1)  
uncomfortable, (2) not very durable, (3) heavy, (4) bulky, or  
(5) awkward to use. These problems are exacerbated for those  
20 persons who are very active. The present invention overcomes

these disadvantages by providing a simple, easy-to-operate prosthetic helping hand with improved comfort and durability.

#### **SUMMARY OF THE INVENTION**

The present invention has the ability to assist  
05 below-the-elbow amputees in performing a variety of tasks. This prosthetic hand comprises a spring-loaded clamping mechanism that is attached to the amputee's lower arm. The clamping mechanism is used to assist in those functions where it is necessary to grasp a cylindrical object.

#### **BRIEF DESCRIPTION OF THE DRAWINGS**

10 FIGURE 1 represents an exploded view of the elements making up the prosthetic helping hand.

FIGURE 2 represents an assembled view of the elements making up the prosthetic helping hand with some of the elements  
15 shown in section for clarity.

FIGURE 3 represents a perspective view of the prosthetic helping hand in fully assembled form holding a cylindrical object.

#### **DESCRIPTION OF THE PREFERRED EMBODIMENT**

20 A preferred embodiment of the present invention comprises a cuff, an anchor, a spring, a ball-and-socket, and a clamping mechanism.

Figure 1 shows a cuff 10 having an open end 11 and a closed end 12. The cuff 10 fits over the amputee's lower arm and is usually custom made to provide an individual fit.

Figure 1 also shows an anchor 20 attached the closed end 05 12 of the cuff 10. In the embodiment shown, the anchor 20 consists of (a) an anchor plate 21 having a threaded hole 22 and (b) a threaded rod 23 having a first end 24 and a second end 25. The anchor plate 21 is preferably triangular in shape and may be cast directly into the cuff 10. The triangular 10 shape of the anchor plate 21 prevents pull-out of the anchor 20. The first end 24 of the threaded rod 23 is screwed into the threaded hole 22 of the anchor plate 21. Alternatively, the threaded rod 23 may be made as an integral part of the anchor plate 21. Where the threaded rod 23 is not integral 15 with the anchor plate 21, the first end 24 and the second end 25 of the threaded rod 23 may have either different diameters, as shown, or the same diameter. The anchor 20 also has a bearing surface 26.

A spring 30 having a first end 31 and a second end 32 is 20 also shown in Figure 1. The first end 31 of the spring 30 bears against the bearing surface 26 of the anchor 20. In the embodiment shown, the bearing surface 26 is on the second end 25 of the the threaded rod 23 and is recessed to provide lateral stability for the spring 30.

Continuing to refer to Figure 1, a ball 40 having an extension 41 bears against the second end 32 of the spring 30. In the embodiment shown, the extension 41 is generally cylindrical in shape. The ball 40 pivots on the spring 30, 05 even when the spring 30 is compressed between the ball 40 and the anchor 20.

A socket 50 is used to hold the ball 40 and the spring 30 in place against the anchor 20. When the socket 50 is attached to the anchor 20, the spring 30 is compressed between the 10 anchor 20 and the ball 40. The socket 50 may be mounted to the anchor 20 either in a manner that provides no adjustment or in a manner that provides adjustment. The adjustable mount is by far the better alternative since it allows the compression on the spring 30 to be changed. The compression on the spring, in 15 turn, varies the amount of force necessary to pivot the ball 40 within the socket 50. In the embodiment shown in Figure 1, the socket 50 is threaded to match the second end 25 of the threaded rod 23 of the anchor 20 in order to provide an adjustable mounting. To enhance the ability of the ball 40 to 20 pivot with a minimal amount of wear, the socket 50 may be provided with a concave spherical surface 51 having a diameter approximately equal to that of the ball 40 so that the spherical surface 51 engages the ball 40 when the socket 50 is mounted to the anchor 20. Additionally, a conical surface 52, 25 which intersects the concave spherical surface 51, may be

provided so that the extension 41 of the ball 40 can pivot against the conical surface 52 rather than a much sharper edge.

Finally, Figure 1 shows a clamping mechanism 60. The clamping mechanism 60 is attached to the extension 41. In the embodiment shown, the attachment is achieved with (a) a cap 61 having a first side 62 and a second side 63 and (b) a channel 64 having an interior surface 65 to match the second side 63 of the cap 61. The first side 62 of the cap 61 is attached to the extension 41. A C-shaped spring 66 (see Figure 2 also) is secured between the second side 63 of the cap 61 and the interior surface 65 of the channel 64. The cap 61 may be soldered to the extension 41 and the channel 64 may be soldered to the cap 61.

Referring now to Figure 2, the C-shaped spring 66 has two ends 67. In the embodiment shown, each of the two ends 67 has a circular member 69 attached. Alternatively, only one circular member 69 could be used on one of the two ends 67. While the circular member 69 can be attached to the C-shaped spring 66 in a number of ways, the preferred method is to provide a slot 68 in the circular member 69 and insert the end 67 of the spring 66 into the slot 68 and solder the spring 66 and the circular member 69 together.

The present invention is utilized by placing an arm that has been amputated below the elbow into the cuff. The clamping mechanism then serves as a hand whenever it becomes necessary

for the amputee to grasp a cylindrical object 70 such as a handle, a bar, a rod, etc. To grasp the cylindrical object, the object is jammed against the opening in the C-shaped spring causing the spring to open, the object to pass to the center of the spring, and the spring to snap shut behind the object (see Figure 3). Various sizes of clamping mechanisms can be provided and easily interchanged to accommodate a variety of diameters. Because the extension 41 pivots and rotates, the clamping mechanism can be used in a variety of orientations. Thus, this invention provides a below-the-elbow amputee with a clamping mechanism which can be used to perform a number of tasks.



ABSTRACT OF THE DISCLOSURE

A prosthetic device for below-the-elbow amputees having a C-shaped clamping mechanism for grasping cylindrical objects. The clamping mechanism is pivotally mounted to a cuff that fits  
05 on the amputee's lower arm.

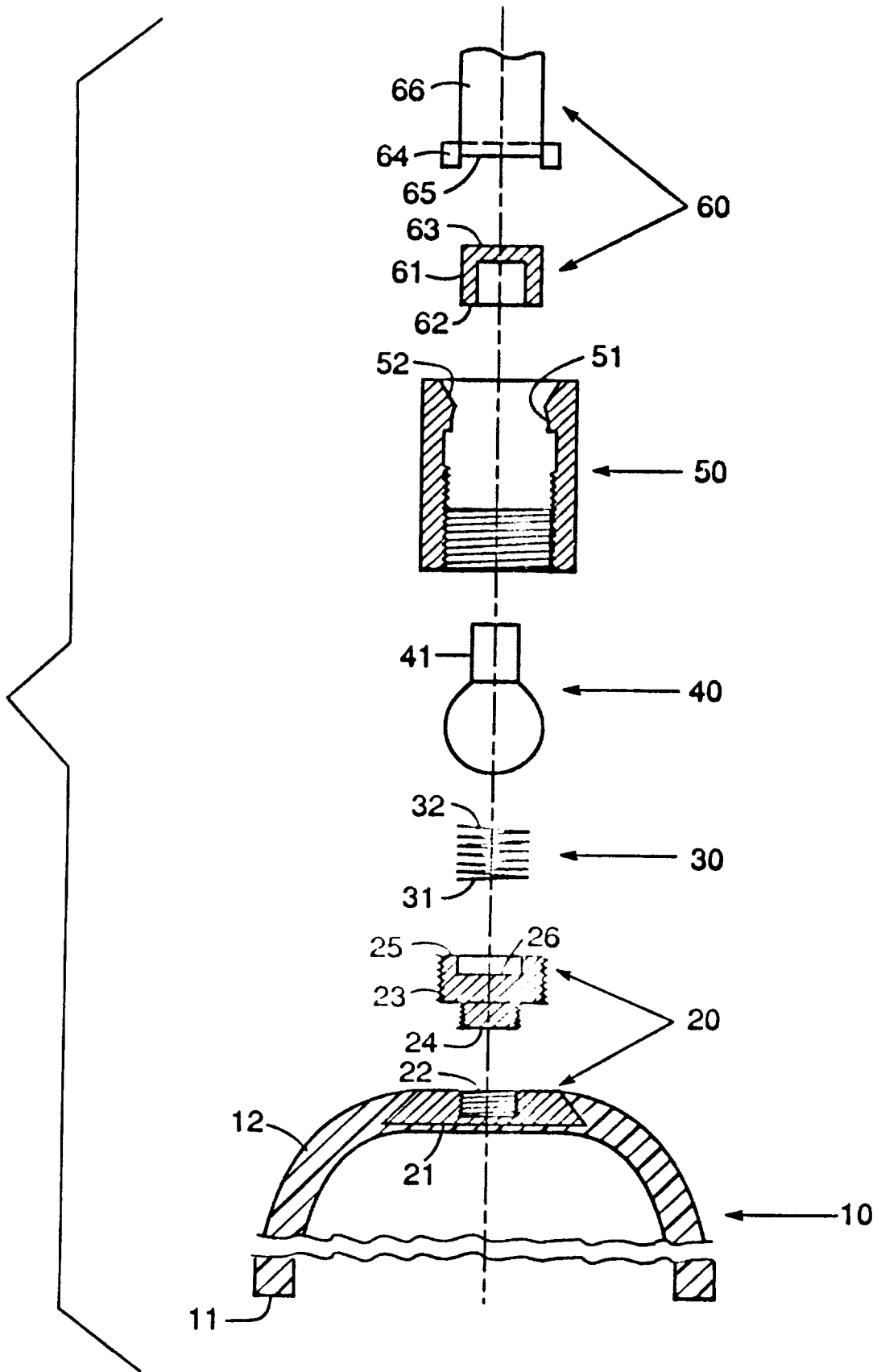

Figure 1

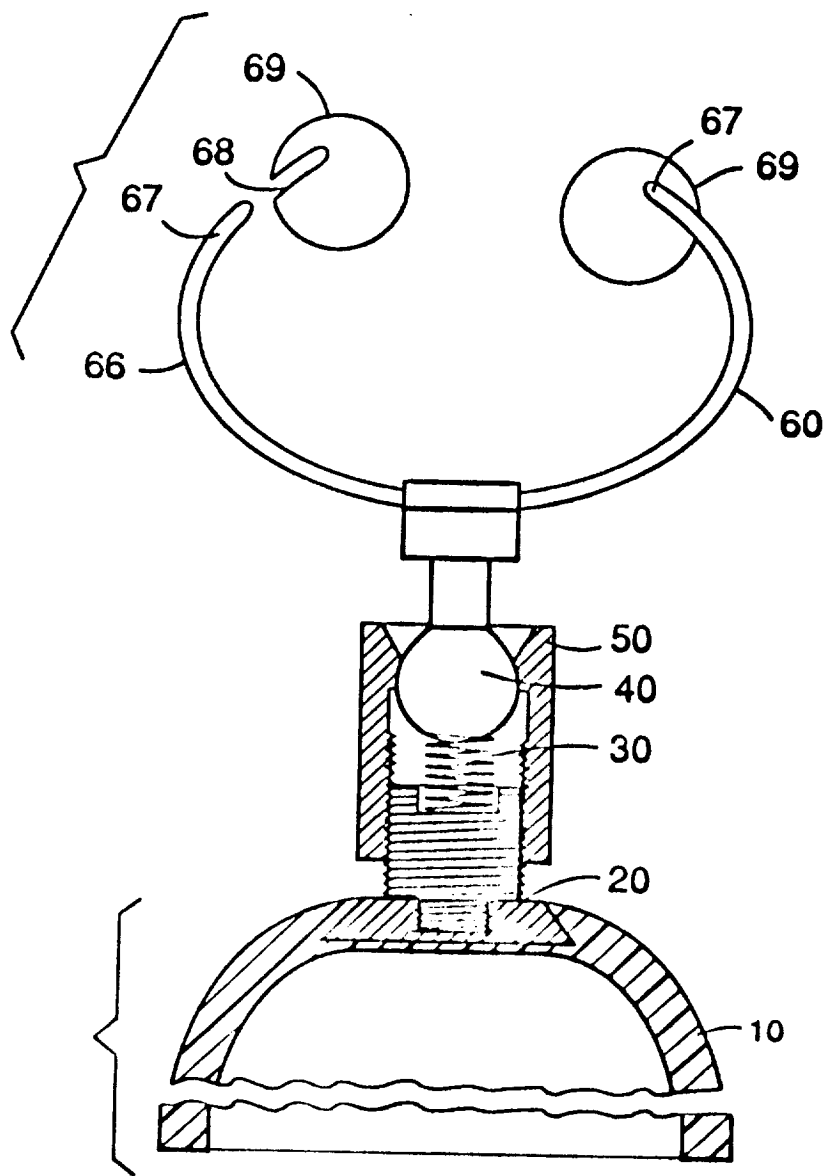

Figure 2

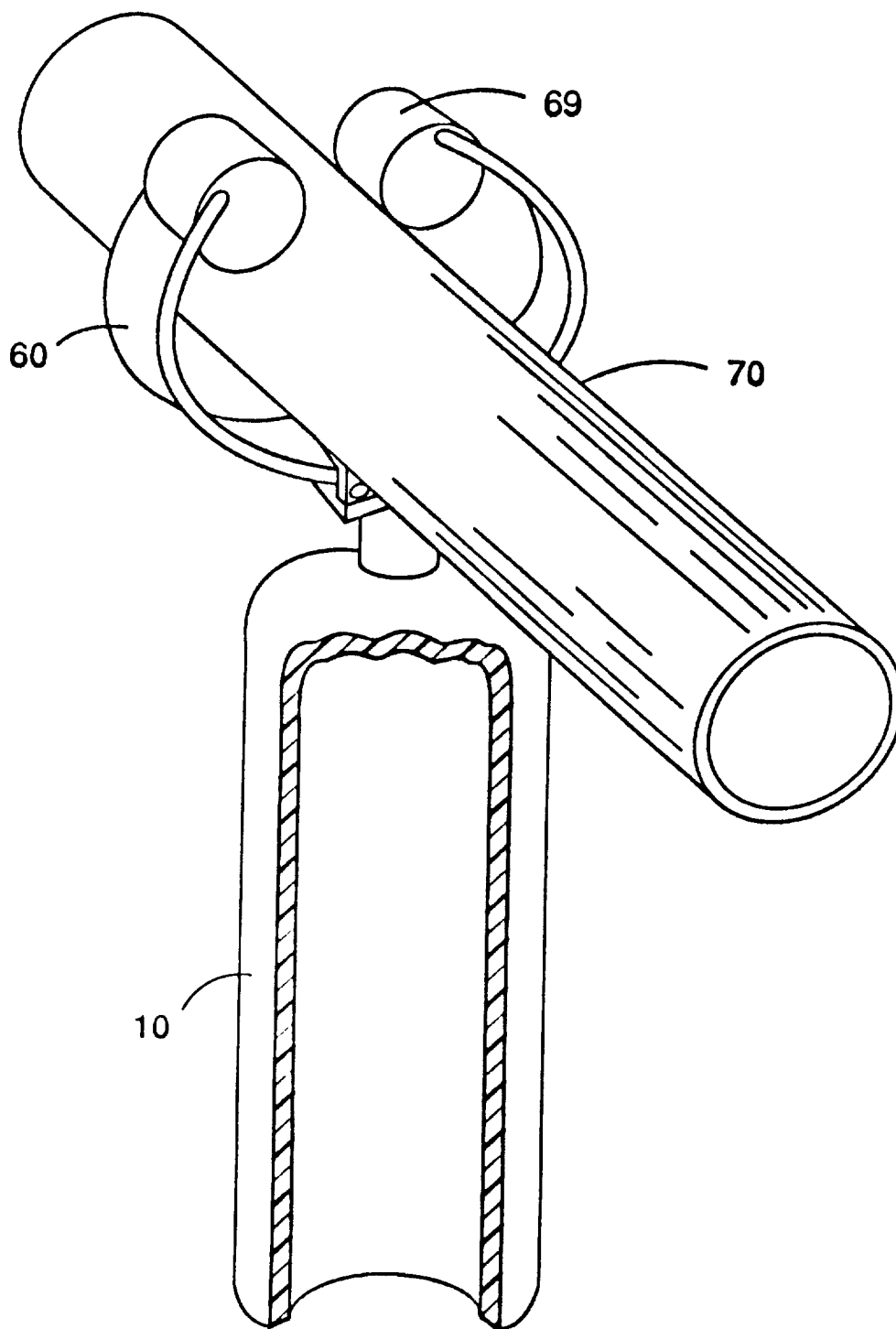

Figure 3