

Linear Transmitter Design for MSAT Terminals

Ross Wilkinson, John MacLeod*, Mark Beach, and Andrew Bateman,
Centre for Communications Research,
University of Bristol,
Queen's Building, University Walk,
Bristol, BS8 1TR, England.
Tel: +44 272 303726, Fax: +44 272 255265

ABSTRACT

One of the factors that will undoubtedly influence the choice of modulation format for mobile satellite, is the availability of cheap, power-efficient, linear amplifiers for mobile terminal equipment operating in the 1.5-1.7GHz band. Transmitter linearity is not easily achieved at these frequencies, although high power (20W) class A/AB devices are becoming available. However, these components are expensive and require careful design to achieve a modest degree of linearity. In this paper an alternative approach to RF power amplifier design for MSAT terminals using readily-available, power-efficient, and cheap class C devices in a feedback amplifier architecture is presented.

INTRODUCTION

Global mobile communication services such as maritime, aeronautical and land mobile are most effectively provided by using satellite transponders. The long range and limited radiated power of the satellites, together with the modest allocation of radio spectrum[1] given to these services necessitates the efficient use of both bandwidth and power, if a service is to be provided for a large user population. The modulation format selected must therefore be tolerant to the restrictive propagation characteristics of the mobile radio channel, if intelligible and reliable communications are to be provided.

*On sabbatical leave from Footscray Institute of Technology, PO Box 64, Footscray, Victoria, Australia.

Tel: +61 3 6884422, Fax: +61 3 6884806.

Significant advances in both analogue and digital modulation techniques have been made for both this and the closely related field of terrestrial mobile communications. The majority of modulation techniques currently used for analogue and digital radio are in existence not because of their spectral efficiency, but rather because of their compatibility with non-linear RF amplifier technology. Examples are analogue frequency modulation and constant-envelope data modulation formats (MSK, GMSK, TFM, etc.). However, techniques which combine both amplitude and phase modulation, such as analogue linear modulation (single sideband)[2] and M-ary QAM[3], have significant advantages in terms of power drain and spectral efficiency, and thus are well suited to mobile satellite applications[4].

Numerous proposals have been made regarding the choice of modulation format for future generation mobile satellite systems. These include the use of amplitude-companded single sideband with a transparent tone-in-band (ACSSB-TTIB) by both the Australians[5] and Canadians[6], and heavily filtered Quadrature Phase Shift Keying by Inmarsat[7] for their Standard-M service. In order to obtain the necessary adjacent channel performance in these systems, it is essential that a linear channel is employed. This requirement dictates the use of either linear, or linearised RF power amplifiers.

This paper describes a simple technique for the linearisation of high efficiency class C amplifier stages using feedback compensation. New results obtained for a linear transmitter system operating at 1.7GHz are presented here, and compared with results previously obtained at 900MHz[8],[9].

LINEAR POWER AMPLIFIERS

The requirements of efficient spectrum utilisation, good power-efficiency, and compatibility with any modulation scheme can only be met by a completely *linear* transmitter. To date, all linear transmitters have utilised devices operating in classes A or AB, where their characteristics are approximately linear. These transmitters, with their poor efficiency, and large heatsinks, have not been attractive in small battery-powered equipment.

The use of a high-gain, narrow-band feedback loop allows amplifiers whose open-loop characteristics are far from linear to be employed[10]. A class C RF amplifier, for instance, would normally only be suited to constant-envelope signals, but the prototype amplifiers here described have achieved excellent performance with a two-tone test signal, the most rigorous test of linearity. The advantages of class C amplifiers over their more linear counterparts are increased efficiency (a most important factor in battery-powered systems), and reduced size (since they require a smaller heatsink). In addition, they do not suffer from the gradual deterioration in performance due to drift in the bias point, etc.

IMPLEMENTATION OF THE CARTESIAN LOOP TRANSMITTER

Essentially, the transmitter is a direct conversion design: the baseband message information, in quadrature components, is modulated directly onto the local oscillator, without the use of any intermediate frequency translation. The quadrature components of the modulation are generated by digital signal processing, and hence the channel filtering, and modulation scheme are controlled in software, and may easily be reconfigured.

Any modulation which can be represented in the form of two quadrature channels, whose bandwidth does not exceed the transmitter's linearised bandwidth, may thus be upconverted and amplified without distortion.

A schematic of the transmitter is shown in figure 1. The I and Q components of the modulation are supplied by the DSP, and modulated onto the LO via a phasing/Weaver method upconverter. A series of amplifiers

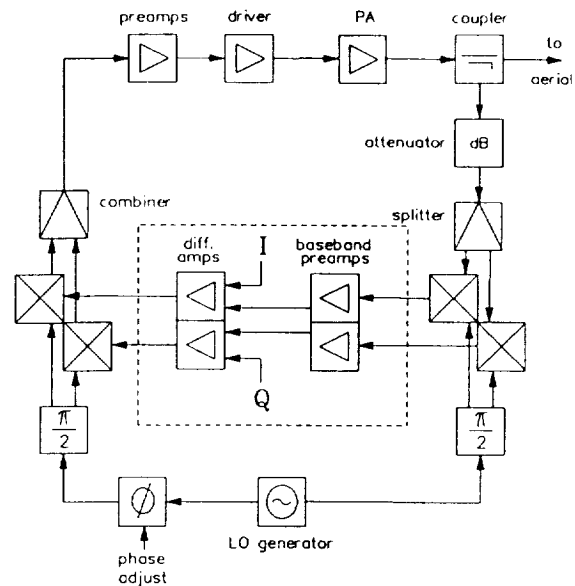

Fig.1 Schematic of the cartesian loop transmitter.

bring the low-level output from the mixers up to the required output power. The amplifiers in this chain are progressively more non-linear, with the final stage being in class C. After the amplifiers, a directional coupler samples the output signal, which is then attenuated and fed into a quadrature demodulator, akin to the upconverter. A pair of identical differential amplifiers, one in each quadrature arm, derive error signals between the required modulation (from the DSP) and the downconverted output. It is these error signals which drive the upconverter. Figure 2 shows an ideal two-tone test signal, and the error signal generated in the feedback loop around a class C amplifier: the distortion in this signal is exactly complementary to that in the amplifiers and upconverter, and thus the output is undistorted. The plot shows the predistortion to be most evident near the minimum of the modulation envelope, where the class C stage is in its most non-linear region.

The feedback loop also includes phase compensation, here shown in the local oscillator driving the upconverter. This is required to cancel the phase shift through the amplifiers, coupler and attenuator, so that the downconverted signals are in phase with their respective upconverted counterparts. If this phase was not equalised, then positive feedback around the loop could occur, resulting in wideband spurious outputs. Since the phase shift through the transmitter will vary with operating frequency, this phase equalisation must be altered as the channel is changed.

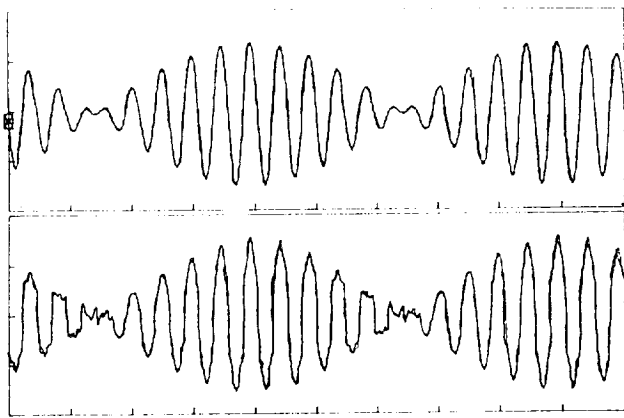

Fig.2 A two-tone test signal and predistorted error signal.

The loop dynamics are controlled by the differential amplifiers: the aim is the greatest suppression of distortion, whilst maintaining overall stability. The gain and bandwidth of the feedback loop must be designed accordingly.

DC offsets in the differential amplifiers and the mixers in the up- and down-converters will result in an unwanted RF output at the local oscillator frequency. This will change with operating frequency, time, temperature, etc, and so steps must be taken to null out this residual DC. The use of a TTIB-based system will relax considerably the need for this suppression, since the unwanted DC will be insignificant compared with the level of the pilot tone.

RESULTS FROM PROTOTYPE SYSTEMS AT 1.7GHZ AND 900MHZ

Two prototype systems have been constructed, both employing diode-ring mixers in the up- and down-converters, and using the same differential amplifier configuration, consisting of a first-order loop with a bandwidth of 10kHz (note that this is effectively 10kHz on either side of the local oscillator, i.e. a 20kHz correction bandwidth).

The 1.7GHz system included an ACR 2001 transistor as the final class C amplifier, and figure 3 shows the results achieved with feedback, compared with the open-loop performance. The tones are spaced at 4.2kHz, and the output power is 400mW PEP. Although the device is capable of more output, initial tests showed that it was not possible to achieve stable closed-loop operation at higher power levels. Examination of the gain/phase characteristics of the amplifier chain over the top 10dB of the

output range, figure 4, shows an abrupt change of over 35dB and 120°: much more than can be accommodated by the gain and phase margin of the loop.

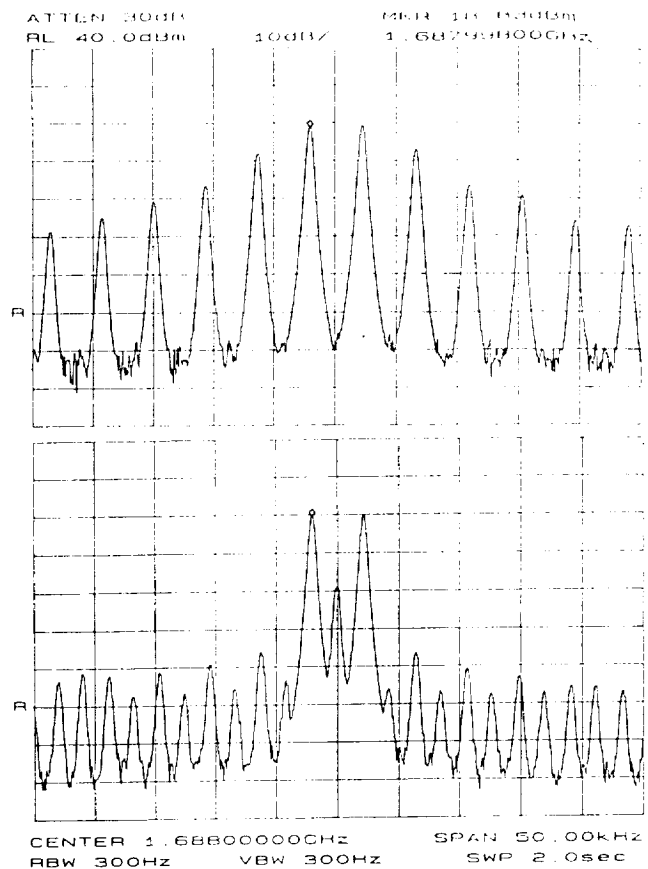

Fig.3 Transmitter for 1.7GHz open- and closed-loop.

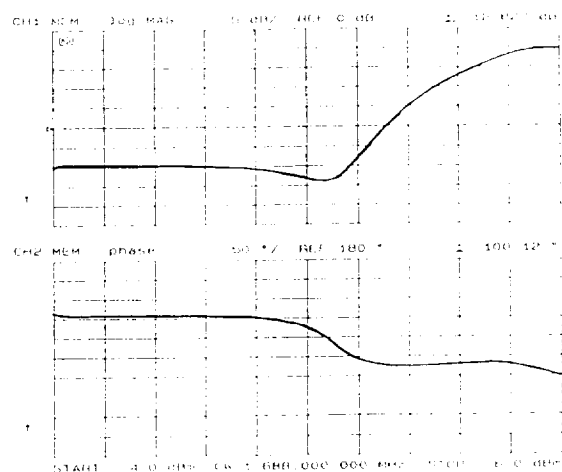

Fig.4 Gain/phase characteristic for 1.7GHz amplifier.

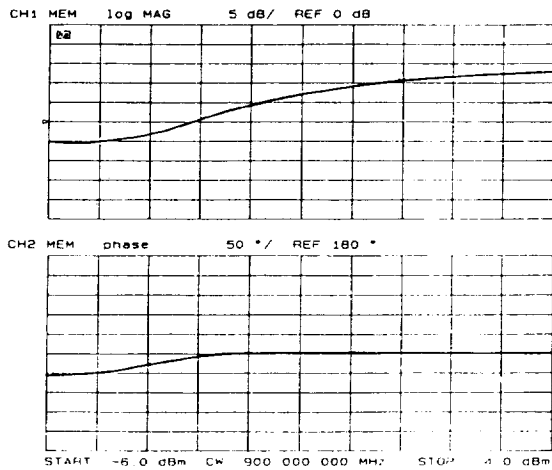

Fig.5 Gain/phase characteristic for 900MHz amplifier.

For comparison, figure 5 shows the same measurement for the 900MHz system: here the change is more gradual, 15dB and 60°, but this is still a class C amplifier, (here an NE080191 transistor). The open- and closed-loop plots at an output of 1W PEP (full power) are shown in figure 6. This illustrates what may be achieved with an efficient linearised class C transmitter.

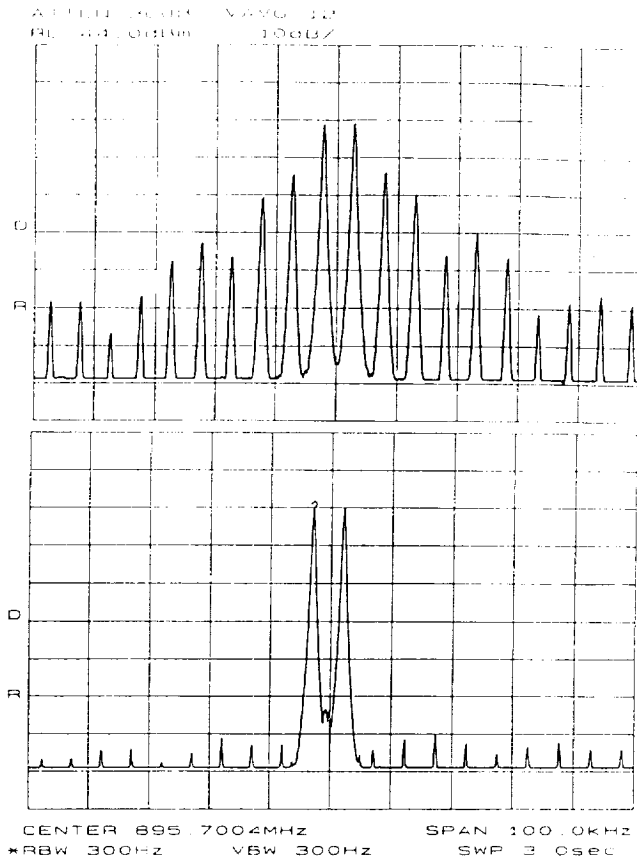

Fig.6 Transmitter for 900MHz open- and closed-loop.

CONCLUSIONS

It has been shown, using the cartesian feedback technique at 900MHz, that excellent intermodulation suppression (>60dB for a two-tone test signal) and good power efficiency (55-65%) can be obtained. Initial results at 1.7GHz show that although the feedback loop performs just as well at this frequency, the amplifier itself requires careful design. The use of a RF non-linear simulation software package would facilitate the design of such an amplifier, and work in this field should soon be underway at Bristol. Some advantage may also be gained by using higher-order feedback loops, to more carefully tailor the gain and phase margin of the system.

Hence, linear power amplifiers for future generation mobile satellite terminal equipment can be designed using a linearised class C architecture, which has better linearity and power efficiency performance than its class A counterpart. Besides mobile satellite applications, another major driving force behind the development of linear transmitter architectures at 1.7GHz is the personal communication networks (PCN's), which is also being addressed at Bristol. In addition, other techniques for linearising amplifiers, offering wider channel bandwidths and power efficiency are also being considered. These include adaptive predistortion and LINC[11].

ACKNOWLEDGEMENT

The authors wish to thank David Bennet for his invaluable help with the fabrication of the up- and down-converters and the loop phase shifter for the 1.7GHz system.

REFERENCES

- [1] **M.Goddard**, 'Frequency Allocations for Mobile Satellite Systems and Satellite Navigation,' IEE 4th Int. Conf. on Satellite Systems for Mobile Communications and Navigation, CP294, Oct 1988, pp10-14.
- [2] **A.Bateman & J.P.McGeehan**, 'A Survey of Potential Narrowband Modulation Techniques for use in Satellite and Cellular System,' Second Nordic Seminar on Digital Land Mobile Radio Communications, Sweden, 1986.
- [3] **K.Feher**, 'Digital Communications,' Prentice-Hall, 1983.
- [4] **W.J.Whitmarsh, A.Bateman & J.P.McGeehan**, 'Analogue and Digital Linear Modulation Techniques for Mobile Satellite,' Second International Mobile Satellite Conference, Ottawa, Canada, June 1990.
- [5] 'Trials Report on the Subjective Performance of Modulation Techniques for Mobile Satellite,' Australian Telecom Internal Report, 1989.
- [6] **J.S.Butterworth**, 'Satellite Communications Experiment for the Ontario Air Ambulance Service,' *ibid* [1], pp83-86.
- [7] 'On the Subjective Voice Quality Test of ACSSB Modulators and Digital Vocoders,' Inmarsat Internal Document, 1989.
- [8] **A.Bateman & R.J.Wilkinson**, 'Linearisation of Class C Amplifiers using Cartesian Feedback,' IEEE Workshop on Mobile and Cordless Telephone Communications, London, Sept 1989, pp 62-65.
- [9] **A.Bateman, D.M.Haines & R.J.Wilkinson**, 'Direct Conversion Linear Transceiver Design,' IEE 5th International Conf. Mobile Radio & Personal Communications, Warwick, Dec. 1989, pp 53-56.
- [10] **V.Petrovic**, 'Reduction of Spurious Emission from Radio Transmission by means of Modulation Feedback,' IEE Conf. Radio Spectrum Conservation Techniques, Sept. 1983, pp 44-49.
- [11] **A.Bateman, R.J.Wilkinson & J.D.Marvill**, 'The Application of DSP to Transmitter Linearisation,' 8th Euro. Conf. Electrotechnics, Stockholm, June 1988.