

N 9 2 - 2 4 4 0 9**INTEGRATED GEOMETRY AND GRID GENERATION SYSTEM
FOR COMPLEX CONFIGURATIONS**

Vedat Akdag* , Armin Wulf*
Control Data Corporation
Irvine, CA 92714

SUMMARY

A grid generation system has been developed that enables grid generation for complex configurations. The system called ICEM/CFD is described and its role in computational fluid dynamics (CFD) applications is presented. The capabilities of the system include full computer aided design (CAD), grid generation on the actual CAD geometry definition using robust surface projection algorithms, interfacing easily with known CAD packages through common file formats for geometry transfer, grid quality evaluation of the volume grid, coupling boundary condition set-up for block faces with grid topology generation, multi-block grid generation with or without point continuity and block to block interface requirement, and generating grid files directly compatible with known flow solvers. The interactive and integrated approach to the problem of computational grid generation not only substantially reduces manpower time but also increases the flexibility of later grid modifications and enhancements which is required in an environment where CFD is integrated into a product design cycle.

INTRODUCTION

The basic techniques in numerical grid generation involve geometric modeling of an object and generating a three-dimensional grid of points that surround the object. In recent years, major advances have been made in flow solvers and visualization software for post processing. The major pre-processing task which is grid generation has not benefitted from the technology gains of the recent past.

The state of the art of Computational Fluid Dynamics has taken rapid strides in recent years with the development and application of unified, robust and efficient methods. Low speed subsonic flows to hypersonic flows around various configurations from internal flows to external flows with various flow physics can be calculated using Navier-Stokes Computational Fluid Dynamics codes. Recent codes available in the industry are constructed using a synergistic approach of many solution methodologies. A multizonal structured grid can be employed to treat complex geometric topologies with ease.

* Consultant

The area of computational grid definition in CFD continues to require a high level of time and manpower and therefore has become widely recognized as a primary bottleneck in CFD analysis. The problem arises from the fact that grid generation takes on a more difficult character with increasing complexity in the geometry. Given the computational grid, today's engineers can simulate fluid flow around very complicated geometries. Efforts in geometry manipulation, surface grid generation and volume grid generation for a typical research project become primary schedule drivers. The result is an unacceptably long turnaround time for complex CFD problems. Previously, a typical pre-processing task from geometry manipulation to actual computational grid generation is shown in Figure 1.

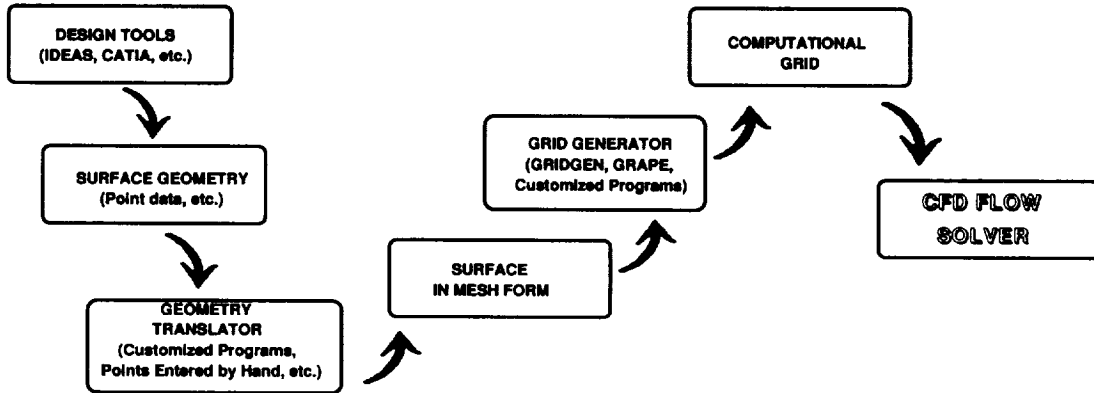

Figure 1: Traditional CFD Grid Generation

Despite considerable attention by researchers in recent years, geometry definition and grid generation still consumes a fair amount of time in CFD analysis cycle time. For complex configurations, this cumbersome procedure can take up to 80% of the effort spent on initial CFD analysis tasks (Figure 2).

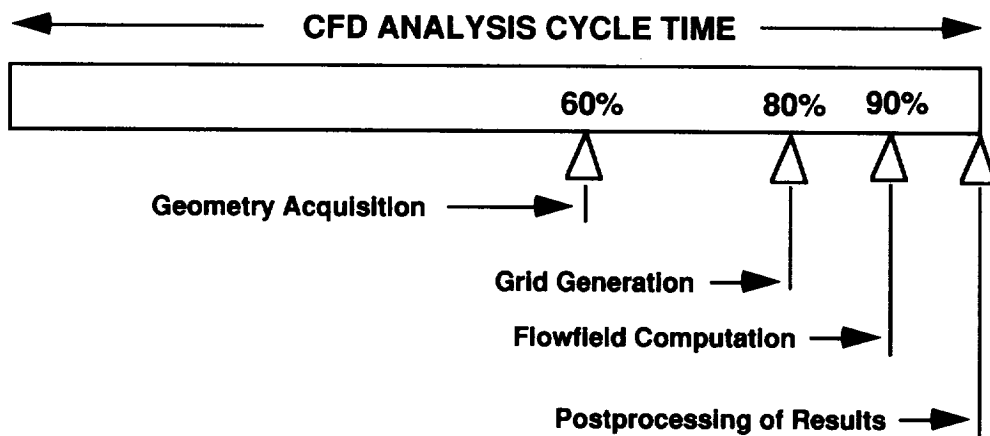

Figure 2: Traditional CFD Analysis Cycle

In many cases surface points are generated by custom programs or entered into a file for grid generators by hand. This can produce unsatisfactory results because the actual geometry definition will be altered as the computational grid is generated. Currently the majority of CFD application engineers do not have the capability of accepting CAD models in standards used by the industry (i.e. IGES CAD geometry definition). This can cause delays in schedules when a design change occurs and CFD analysis cannot be completed in a timely manner. To overcome this problem and to insure the quality of analysis, an integrated CAD and Grid generation package is needed. This approach can shorten the pre-processing procedure by a considerable amount (Figure 3).

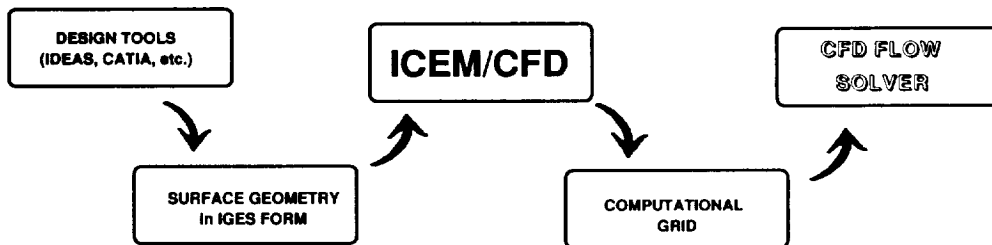

Figure 3: CFD Grid Generation with ICEM/CFD

CAD geometry can be taken from design tools and decomposed into meshable pieces while the association between the computational grid and the CAD model are maintained. This computational grid then can be fed directly into CFD flow codes. The main criteria used to select the grid generator are summarized below.¹

- Minimize duplicate model generation
- Use direct path from/to master CAD model
- Robust algorithms that generate grids quickly
- Body fitted quality grids on master or deformed model
- Assured grid accuracy for Navier-Stokes analysis
- Reflect changes to master model quickly
- Managed CFD environment integrated into product design cycle

It is obvious that considering the recent advancements in the computer hardware and software technology, the amount of computer flow simulation data that will go into future aircraft design should greatly increase, as should the overall impact of CFD on design process. CFD analysis will become one of primary functions in product design. Today many companies are moving towards concurrent engineering concepts (Figure 4).

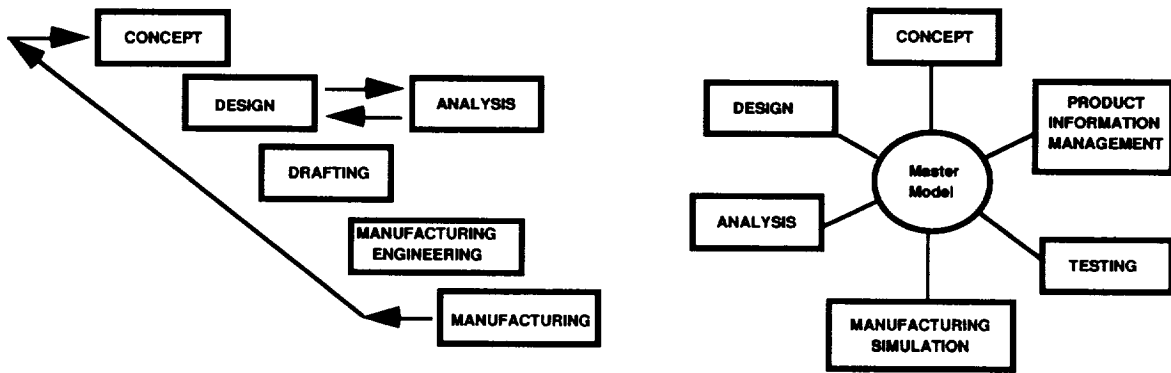

Figure 4: Product Development, Traditional versus Concurrent Engineering

Today, many companies achieve this goal through standardization on a CAD system for conceptual design, detailed design, analysis and manufacturing where master model concept is maintained throughout the process of getting the product to the customer. The change from traditional product development to a concurrent engineering approach requires a master model concept. The master model is used by different departments involved in model analysis as a means of transferring results from one department to another (Figure 5). The associated results based on the master model transferred between departments. In cases where the chosen CAD system is inadequate for performing computational grid generation for analysis, the requirement of data exchange (mainly geometry) between the grid generation tools and the CAD system becomes mandatory. CAD systems define geometry by using parametric curves and surfaces, whereas analysis environment represents a body using a set of discrete points. Acquiring continuous discrete body points (surface in mesh form) from CAD geometry requires robust surface projection algorithms, where gaps between surfaces, overlaps, and discontinuities on the surface structures do not create problems.

Currently structured zonal grid generation softwares, operate on the surface mesh in point data format.^{2,3,4,5} They do not possess the advantages of ICEM/CFD's full CAD capability integrated with 3D grid generation functionality. There have been some efforts in utilizing CAD systems to enhance surface grid generation capabilities. This approach requires a considerable investment in time and money. The main problem is not in CAD capabilities but in the absence of adequate means for converting CAD data to CFD formats effectively⁶. Given an integrated tool like ICEM/CFD engineers can devote more time on the actual analysis of the flow solver results rather than tedious geometry acquisition and definition, and grid generation issues.

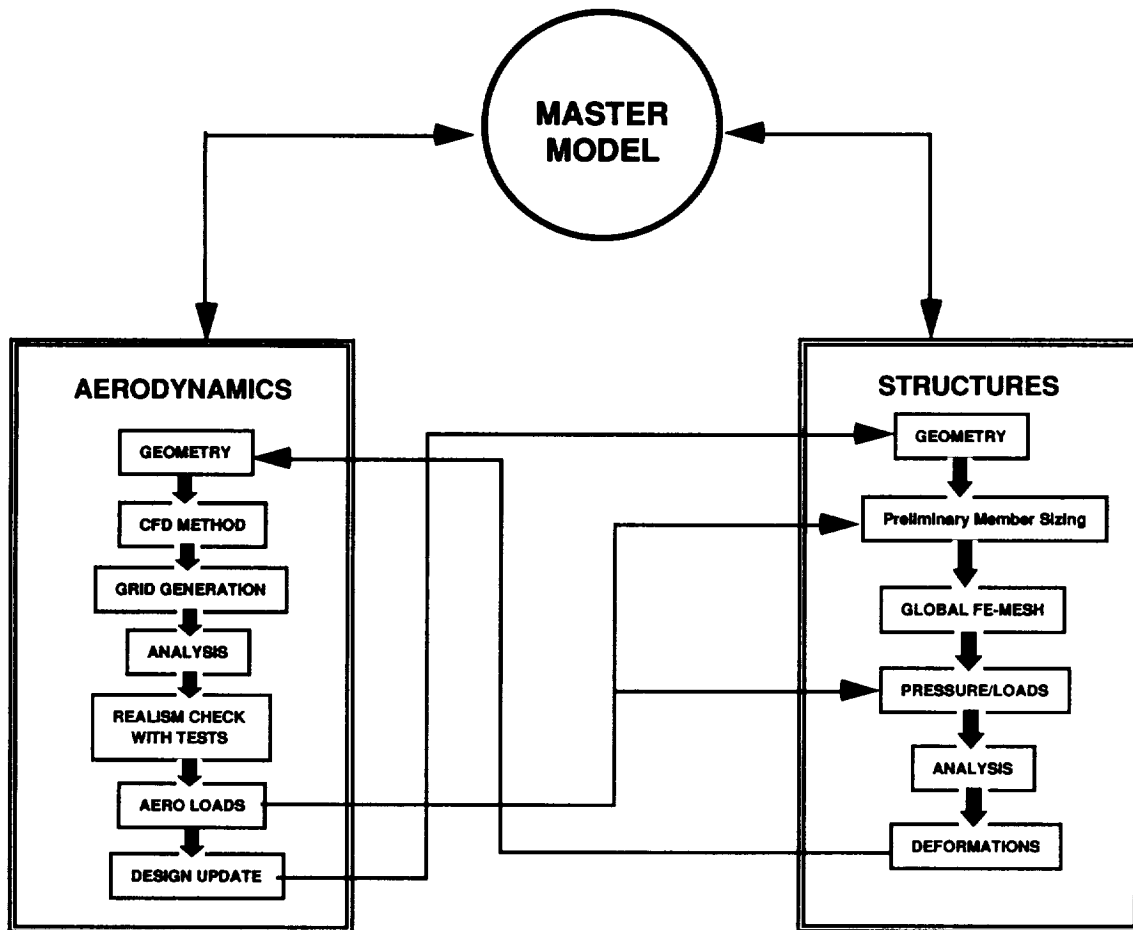

Figure 5: Integrated analysis environment into product design.

USE OF INTEGRATED GRID GENERATION TOOL

ICEM/CFD's excellent CAD capabilities support the creation of wireframes, 3D curves, regular surfaces, and multiple segment NURBS surfaces. It can generate and receive standard open CAD formats (i.e. IGES, SET, VDAFS, DXF) for data exchange with other CAD packages. After the vehicle geometry is read from other CAD packages, depending on the geometry configuration, a CFD application engineer can create blocking for completely new configurations with ease. An interactive user interface reduces the man-hours required to create, modify, and verify a grided configuration. It provides excellent tools for interactive topology generation for multiple block structured grid configurations. It can generate multi-block structured grids with or without point continuity and block to block interface requirement. When the point continuity required between blocks the system automatically checks the inter-block connectivity. Boundary conditions and inter-block connectivity information are generated and output automatically. The geometry can be represented using B-spline surface patches and the grid points on the surface are calculated by projection. Computational grid is not dictated by

surface patch structure. This allows the underlying geometry to be modified with no impact on the topology of the grid structure. Robust surface projection algorithms tolerate gaps, overlapping and sharp edges of surface geometry definitions. After the topology and connectivity information is generated, surface and volume grid generation is automatically performed. Computational grids required by viscous fluid flow solvers can be generated using ICEM/CFD, since it embodies the capability of generating grid points in double precision with grid relaxation and adequate bunching algorithms.

ICEM/CFD APPLICATIONS

A grid generation system is measured not only by its algorithms, but also by the multi-block and complex grids that it can generate. One also has to consider the CFD application process as a part of the product design cycle, where geometries of complex configurations are expected to be analyzed. Current ICEM/CFD applications vary from internal flow grids to external flow applications that cover aerodynamic and aeroheating applications of automotive and aerospace configurations. The blocking strategy for an application may be approached in several different ways. The user must make grid topology decisions based on his prior experience and flow solver capabilities. These decisions can be made without being limited to the grid generation tools since very complicated geometries can be grided using ICEM/CFD.

Multibody Configuration: To demonstrate the ICEM/CFD's capability in handling complex configurations, a multi-body geometry system, consisting of a core body with two strap on boosters of a launch vehicle is generated. The main body consists of a spherical nose cap, a conical section, a bulbous cylinder, and a backward facing step (boattail) followed by a long cylinder. The strap-on solid rocket boosters exhibit geometry similarities with the main body (Figure 6). In order to save computational time for the flow field calculations the front section of the geometry is grided using a single zone structure where the computational grid behind the boattail is constructed using five blocks. To generate the 3 dimensional grid around the nose section, a two dimensional surface grid is constructed. Utilizing the tools in ICEM/CFD, the 2D surface grid is rotated around the axis of symmetry to generate the 3D dimensional grid. The edge entities required for the 3D grid are constructed automatically, and the connectivity information between the block face entities is checked in the background by ICEM/CFD. The total flowfield calculation can be carried out by interpolating the flowfield between the single block nose grid and the multi-block grid structures.

Personal Launch System: A multiblock grid configuration of the PLS (Personnel Launch System) / HL-20 transatmospheric vehicle was generated using ICEM/CFD. The geometry of the PLS (Figure 5) was constructed by NASA Langley researchers using SMART, a solid modelling package developed at NASA Langley for Silicon Graphics Iris 4D workstations. Since SMART output was available in the form of PATRAN neutral files, the PLS geometry was converted into IGES format using PATRAN. The surface geometry, as B-spline surfaces was then read into ICEM. An orange peel type C grid was constructed around the nose area for improved stability of the flow solver at high Mach number and high angle of attack flight conditions. The construction of O type grid blocks around the wing and the vertical tail allowed grid point clustering around these surfaces (Figure 7).

B-2 like aircraft: Figure 8 shows a B-2 like aircraft, where a single block grid structure is used to grid the upper portion of the airplane. The surface grid points are projected on the underlying NURBS geometry. The tools available in ICEM/CFD, provide visualization of the face grid structure of the computational blocks before the full 3D grid is calculated.

Turbine Blade: The turbine blade configuration is grided using multi-block grid topology with an O-type grid around the near region of the blade where H-type grids fill the regions between consecutive blades. During the grid point clustering along block edges, the grid distribution on the block faces can be displayed for fine tuning. The output of this grid structure can be written in various flow solver formats currently used in the industry. Boundary condition on the block faces can also be attached to the grid points for output.

FUTURE WORK

CFD will continue to be applied to numerous interesting and challenging problems that will push the state of the art in the discipline. A considerable number of these problems exist for which CFD will be beneficial and sometimes absolutely necessary.

One of these challenges is to establish a new computational environment that is intended to support a multi-disciplinary approach to the design of advanced aerospace configurations. Designers of such vehicles can no longer rely on single discipline research tools to identify and understand undesirable design features. A multi-disciplinary design environment that integrates fluid dynamics, aeroelasticity and structural dynamics, electromagnetics and controls can minimize or eliminate additional design iterations taken during the single discipline design process. Most of these disciplines require various types of geometry manipulation and structured or unstructured computational grid generation capability.

The recent advancement in integrated geometry and grid packages, such as ICEM/CFD, will help the integration process for the multi-disciplinary computational environment to achieve synergism in design of advanced vehicles. ICEM/CFD can serve as the center of the master model concept for geometry, engineering analysis, detailed design, and manufacturing. Since integrated packages of geometry and grid generation, such as ICEM/CFD have become available to engineers, more time can be spent on the actual analysis of the calculations rather than tedious grid generation.

ACKNOWLEDGMENTS

The authors wish to acknowledge the efforts of Control Data, ICEM Systems and Aircraft Division of Aerospatiale, France in development of ICEM/CFD and related software.

REFERENCES

1. Rainsberger, R., Wulf, A., *Priorities for CFD-Grid Generation in a Master Model Environment*, 1991 UTECA Conference, Springfield, MA.
2. Visich, M., Boyd, C. N., Widhopf, G. F., Coons, R. E., S-C Huang, Oliphant, P. H., Staal, D. J., Than, P. T., *Advanced Interactive Grid Generation Using RAMBO-4G*, Paper AIAA-91-079, 29th Aerospace Sciences Meeting, January 7-10, 1991/Reno, Nevada
3. Steinbrenner, J. P., Chawner, J. R., and Fouts, C. L., *The GRIDGEN 3D Multiple Block Grid Generation System*, WRDC-TR-90-3022, Vol. I, II, July 1990.
4. Gatzke, T., LaBozzetta, W., Finfrock, G., Johnson, J., Romer, W., *MACGS: A zonal grid generation system for complex aero-propulsion configurations*, Paper AIAA-91-2156, 29th Aerospace Sciences Meeting, January 7-10, 1991/Reno, Nevada
5. Sorenson, R. L., McCann, K. M., *A method for interactive specification of multiple-block topologies*, Paper AIAA-91-0147, 29th Aerospace Sciences Meeting, January 7-10, 1991/Reno, Nevada
6. Ching-Chung Luh, R., Pierce, L. E., Yip, D., *Interactive Surface Grid Generation*, AIAA-91-0796, 29th Aerospace Sciences Meeting, January 7-10, 1991/Reno, Nevada

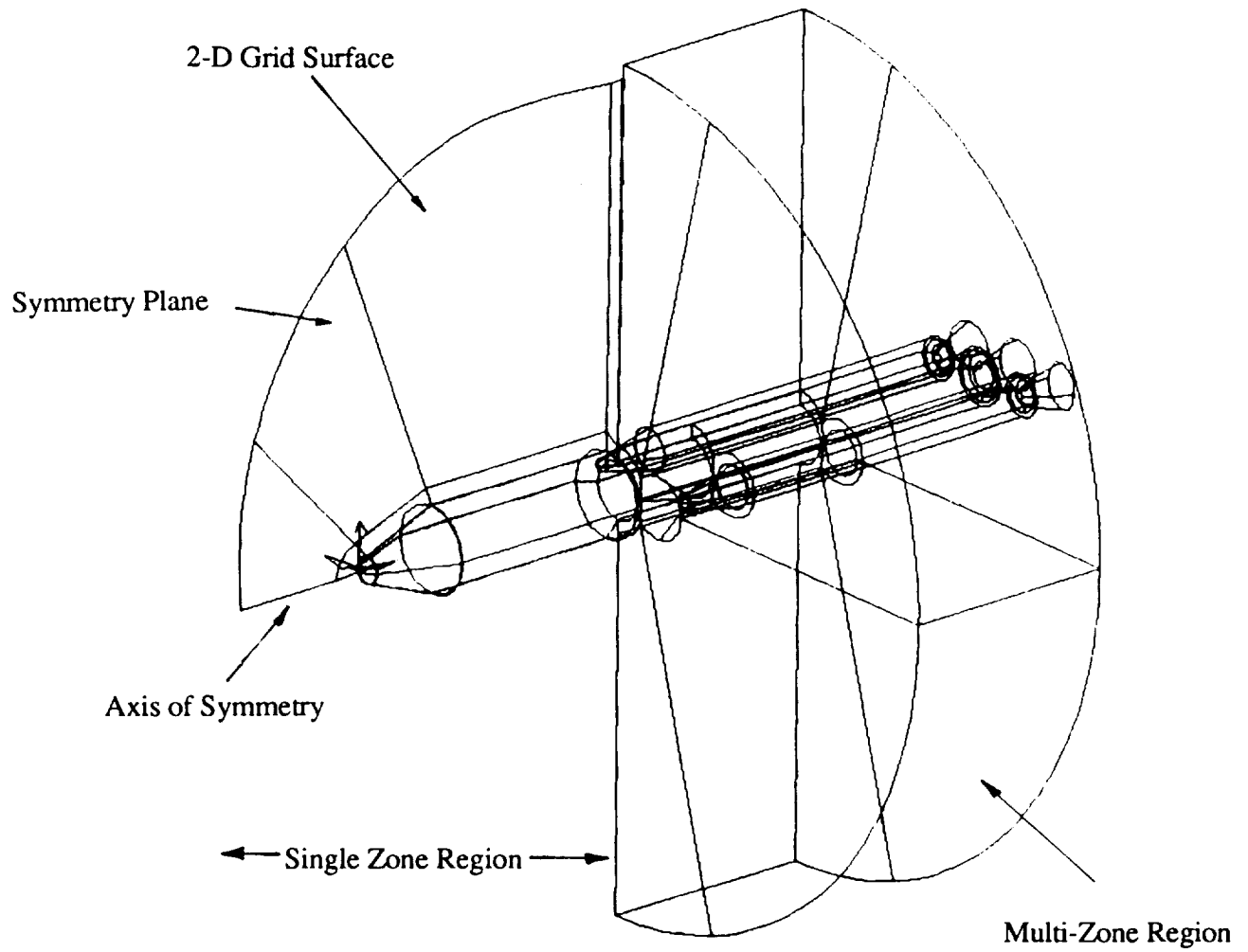
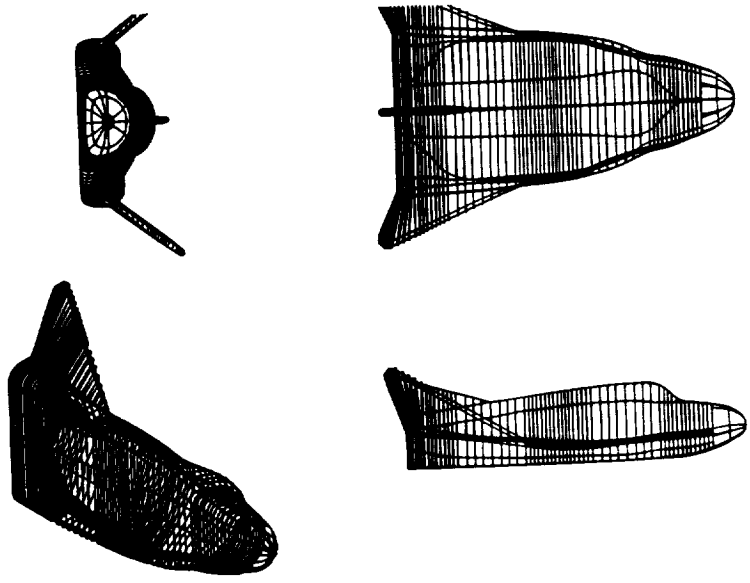

Figure 6



9418 Surface Grid Points, 245282 Flow Field Grid Points

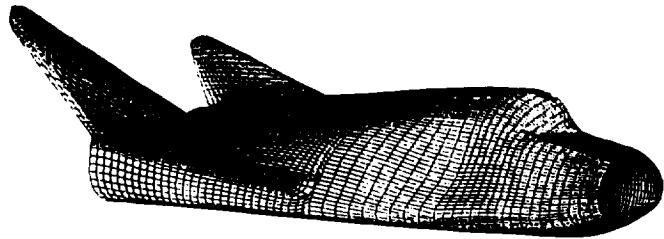

Figure 7

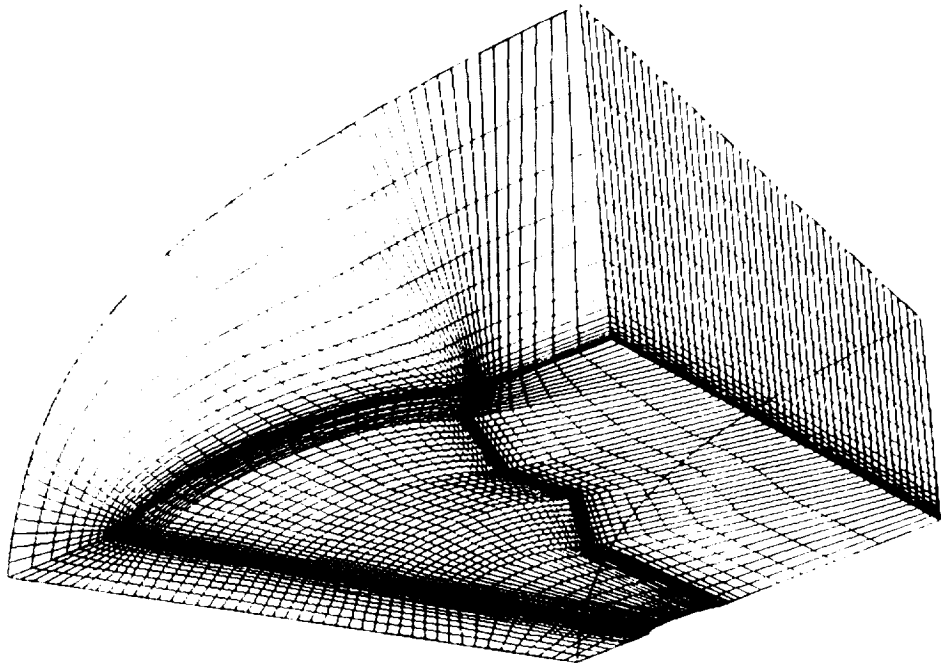

Figure 8

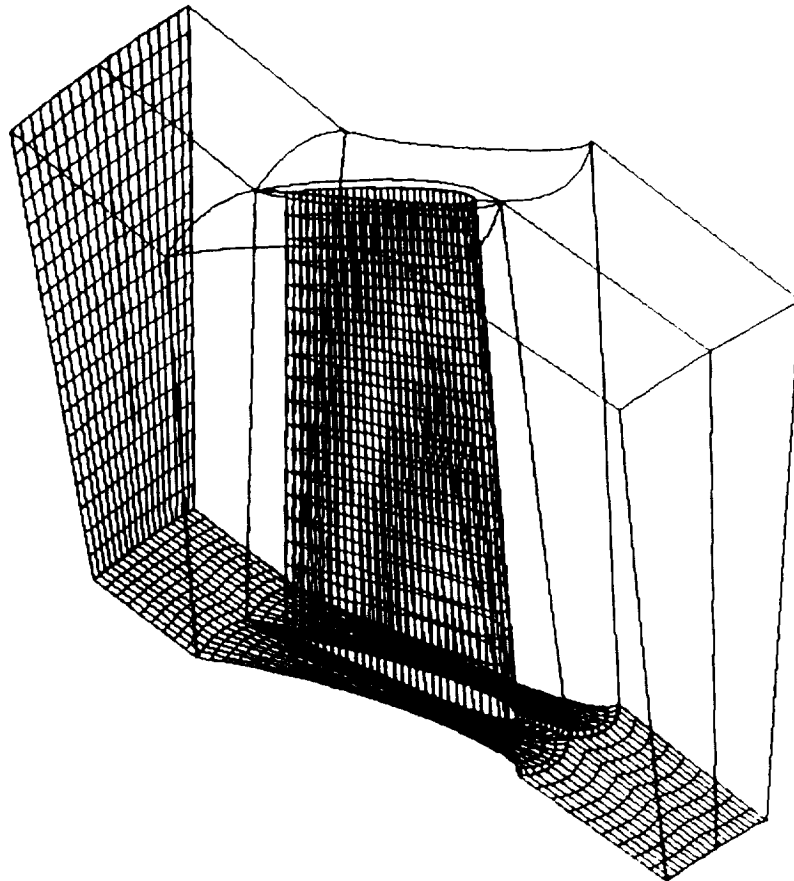

Figure 9

