

NASA
Technical Memorandum 101657

Radar Multipath Study for Rain-On-Radome Experiments at the Aircraft Landing Dynamics Facility

Anne I. Mackenzie
Leo D. Staton

May 1990

Date for general release May 31, 1992

NASA

National Aeronautics and
Space Administration

Langley Research Center
Hampton, Virginia 23665-5225

(NASA-TM-101657) RADAR MULTIPATH STUDY FOR
RAIN-ON-RADOME EXPERIMENTS AT THE AIRCRAFT
LANDING DYNAMICS FACILITY (NASA) 42 p

N92-25137

CSSL 20N

Unclass
0085740

G3/32

11-11-11

11-11-11

11-11-11

**RADAR MULTIPATH STUDY FOR RAIN-ON-RADOME EXPERIMENT
AT THE AIRCRAFT LANDING DYNAMICS FACILITY**

TABLE OF CONTENTS

	PAGE NO.
I. Summary	1
II. Introduction	1
III. Description of the ALDF	2
IV. Rain-On-Radome Experiment Concept	2
V. Radar Multipath Study Method	5
A. ALDF Modeling	5
1. Properties of Radar Transmitter and Receiver	5
2. Reflections From Vertical Portions of ALDF Water Spray Towers	6
3. Reflections From Horizontal Portions of ALDF Water Spray Towers	8
4. Reflections From Horizontal Track Surface	9
5. Attenuation by Rain	10
B. Variation of Multipath Parameters for the Study	10
1. Antenna Beamwidth	11
2. Antenna Height	11
3. Signal Polarization	11
4. Rain Rate	11
VI. Results of the Multipath Study	11
A. Separate Reflectors	11
B. Magnitude of Received Power Oscillations	12
C. Frequency of Received Power Oscillations	12
D. Antenna Height	12
E. Signal Polarization	12
F. Rain Rate	12
VII. Multipath Effects on ROR Experiment Feasibility	13
VIII. ROR Experiment Design Considerations	13
IX. Conclusions	15
A. Feasibility of the ROR Experiment	15
B. Possible Improvements on the Analytical Study	15
X. Appendices	17
A. Plots of Received Signal Power	17
B. Reflection Coefficients for Wet and Dry Concrete	25
C. Computer Program ALDF.FOR	27

SYMBOL DEFINITIONS

SYMBOL	DEFINITION
a	Cylinder radius
b.w.	3 dB beamwidth
BW	Bandwidth
c	Constant dependant on λ
d	Distance
E	Electric field strength
freq.	Frequency
G	Directional power gain
h	Illuminated length of cylinder
h.p.	Horizontal polarization
J_1	First-order Bessel function
k	Wave number or propagation constant
L	Path length from transmitter image to receiver
N	Noise power
P	Signal power
PD	Power density
R	Rainfall rate
r	Receiver
radant	Antenna radius
s	Specular point
t	Transmitter
v.p.	Vertical polarization
α	Angle between signal path and antenna boresight
Γ	Complex coefficient of reflection
λ	Wavelength
v	Constant dependant on λ
σ	Radar cross section
ϕ'	Angle between plane of incident ray, z-axis, x-axis, and plane of reflected ray, z-axis
ψ_i	Angle between incident wave and surface normal
*	Multiply

I. SUMMARY

This paper describes an analytical study to verify that multipath signals would not prohibit a proposed rain-on-the-radome (ROR) experiment at the Aircraft Landing Dynamics Facility (ALDF) at Langley Research Center. The proposed ROR experiment, which would be a follow-up to a wet radome reflectivity experiment performed at Langley in 1984, would measure the attenuation of aircraft weather radar signals when the aircraft radome is immersed in heavy rain. In particular, the experiment would seek out possible reasons for the sudden, complete loss of radar weather images in heavy rain, a phenomenon which has been reported from time to time by aircraft pilots.

In a computer simulation of the ROR experiment, the direct-path (desired) and multipath (undesired) received signals have been calculated and summed to show that the total received signal can be measured with available hardware. The ratio of the direct-path signals with and without rain can then be calculated from measured values of the total received signal. The results of the simulation also imply that horizontally polarized signals would produce more predictable results than vertically polarized signals. The simulation has been performed for conditions of varying antenna position, signal polarization, and rainfall rate. Included with this report are suggestions on how to use the attached Fortran program to choose hardware for such an experiment.

II. INTRODUCTION

Investigations by the National Transportation Safety Board of the crash of one commercial airliner in 1977 and of another in 1980 have suggested that operations in heavy rain may severely degrade the performance of airborne weather radars. The principal proposed effect is the appearance of an anomalous attenuation superimposed on the usual propagation loss when the aircraft radome is immersed in heavy rain. One hypothesis offered to account for the suspected effect is the formation of a thin layer of water on the radome of the aircraft during such operations.

An attempt to quantify this hypothesis was made in a joint NASA/FAA program with results reported in 1984 [1]. In that work a microwave reflectometer was located inside a radome with the entire apparatus placed in a wind tunnel and exposed to airspeeds up to 192 knots and to a dense water spray simulating heavy rain. Any presence of a thin water layer on the radome was expected to result in a large reflection coefficient as measured by the reflectometer. The experiment did not detect such a large reflection coefficient and the authors of reference 1 suggest that a more definitive test would involve a measurement of transmissivity rather than reflectivity. Thus, the question of the existence of the conjectured anomalous attenuation is still unresolved.

It has been suggested that another experimental facility at the NASA Langley Research Center might be used to conduct such a transmissivity test under conditions of very heavy rain. That facility is the Aircraft Landing Dynamics Facility (ALDF), depicted in figure 1. In this paper, the proposed

transmissivity test will be referred to as the rain-on-the-radome (ROR) experiment.

Among the questions affecting the feasibility of such an experiment is the magnitude of the effects of extraneous signals scattered from the ground or other parts of the facility. These multipath signals would be superimposed on the desired signal and would produce signal strength fluctuations that could degrade measurement accuracy. This paper describes the results of an initial feasibility study for the ROR experiment using the ALDF, the principal emphasis of the study being the characterization of such multipath signals.

III. DESCRIPTION OF THE ALDF

The Aircraft Landing Dynamics Facility, depicted in figure 1, contains a 2729-foot track along which a 30-foot tall sled is propelled by a burst of pressurized water [2]. Accelerated at 17g over a 400-foot distance, the sled coasts at a speed of 150 knots until it reaches the arresting cables 2222 feet down the track. During experimental runs, the position of the sled along the length of the track can be determined to within three inches. This measurement is accomplished by the telemetered detection of steel bars every ten feet along the track using a magnetic pickup.

Along the midsection of the track, six steel towers stand at 107-foot intervals. The towers support water sprinklers which can simulate rainfall at the rates of 2, 10, 30, or 40 inches per hour, depending on the nozzle attachments used.

In the past, the ALDF has served in experiments to test the interaction of aircraft landing gear and runway surfaces and to measure the aerodynamic effects of heavy rain on airfoils.

IV. RAIN-ON-RADOME EXPERIMENT CONCEPT

This study considers one possible method of conducting the ROR experiment. In the method under consideration, a transmitting antenna and radome would be mounted on the ALDF sled, which would simulate a flying aircraft by travelling at 150 knots down a straight horizontal track. As the sled moved under the series of sprinklers which simulate heavy rain, X-band radar signals would be sent to a stationary receiving antenna at the far end of the track.

Time histories of the received signals would be recorded and compared to those collected under the same conditions without rain. If the conjectured anomalous attenuation is a real effect, the time history of the received signal would show a sudden drop the moment the radome passed into the water spray.

Both antennas would be flat, circular, slotted array antennas with 3.5 degrees beamwidth and 34.5 dB gain; they would face each other at the same height above ground. Because of the proximity of the water sprinklers to

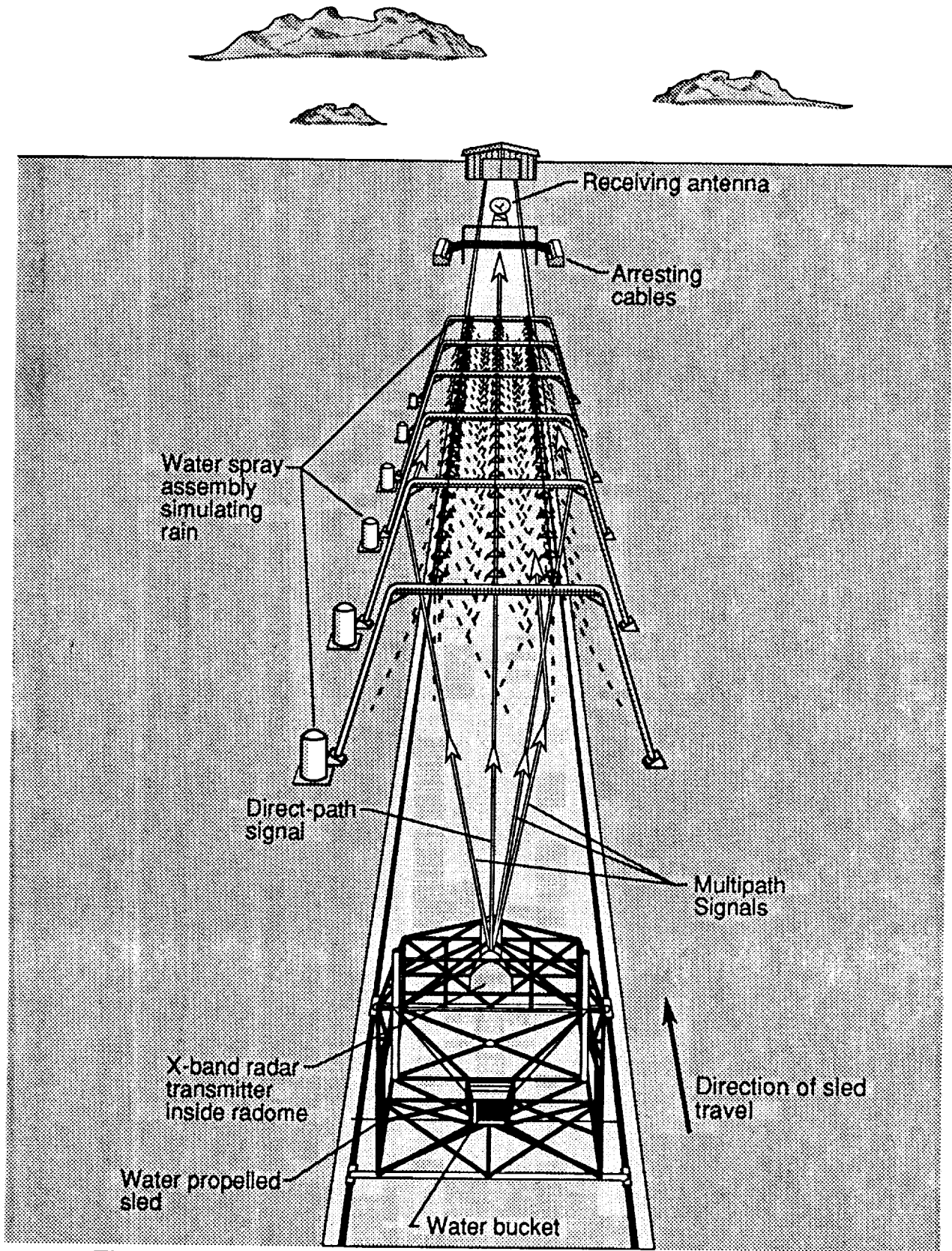

Figure 1.- Rain-on-radome experiment concept showing the Aircraft Landing Dynamics Facility, desired direct path signal, and undesired multipath signals.

the direct signal propagation path between the transmitter and receiver, it might be expected that extraneous multipath signals could be scattered into the receiver in addition to the desired direct signal. The presence of substantial multipath signals could cause the following potential problems for the conceptual transmissivity measurements:

- 1) The multipath signals might add to the direct-path signal to produce a combined signal with very large power fluctuations. During negative fluctuations, signal dropout could occur at the receiver if the transmitted power or receiver signal-to-noise ratio were insufficient. During positive fluctuations, receiver saturation could occur if the receiver's dynamic range were insufficient.
- 2) The total received signal might contain rapid power fluctuations due to the rapidly moving sled. Thus, small errors in sled position measurement could produce errors in total signal measurement that would mask the differences between the measurements taken with and without the radome immersed in simulated rain. The attenuating effect of rain on propagated radar signals can be predicted with existing theory; it is an added attenuation related to rain on the radome which the ROR experiment seeks to measure.
- 3) The total received signal in rain might differ from the received signal under dry conditions in such a way that the recorded signals could not be used to determine the difference in direct-path power under wet and dry conditions.

This study examines signals scattered from the sprinkler system along with the ground bounce multipath signal under conditions of varying antenna position, signal polarization, and rainfall rate. The total multipath signal is then added coherently to the direct signal to produce the expected total received signal as a function of the sled position along the track. The characteristics of this fluctuating signal then allow quantitative assessment of the problems enumerated above.

The Fortran computer program (ALDF.FOR) written for this study models the geometry and reflective properties of the major structural components of the ALDF, shown in figure 1. Relative direct-path and multipath signal contributions to the received signal are those resulting from specular reflections from the following portions of the ALDF structure:

- 1) Vertical portions of the metal towers supporting the water sprinklers
- 2) Horizontal portions of the metal towers supporting the water sprinklers
- 3) The flat portion of the concrete track surface on the ground beneath the sled

V. RADAR MULTIPATH STUDY METHOD

This section describes how the analysis was performed. A Fortran program, ALDF.FOR (See appendix C), was written to calculate the direct-path, multipath, and combined signal power reaching the receiving antenna under varying conditions such as transmitting antenna position, signal polarization, and rainfall rate.

The multipath signals considered are those arising from specular reflections from metal and concrete structures around the ALDF track. These various reflected signals are calculated individually and added as vector quantities to the direct-path signal. The received signal strength is calculated at regular intervals of distance as the sled progresses down the track from start to finish. The results of the calculations are presented later in this report.

A. ALDF Modeling

This section describes how the ALDF physical components' geometry and electromagnetic properties are modeled.

1. Properties of Radar Transmitter and Receiver

The transmitting and receiving antennas are modeled as identical, uniformly illuminated circular apertures of diameter 21.1 inches. They are considered to be located at the same height above the track surface and centered between the sides of the track. The transmitting antenna is considered to be moving through the water spray toward the stationary antenna located behind the arresting cables. For the analytical study, the carrier frequency was chosen to be 9.33 GHz (X-band), making the three dB beamwidth of the antennas approximately 3.5 degrees.

In the following discussion, antenna gains are normalized to simplify power calculations. For the uniformly illuminated circular aperture, antenna directional power gain normalized to its maximum value is computed as [3]

$$G = 4 \left| \frac{J_1(k * \text{radant} * \sin \alpha)}{k * \text{radant} * \sin \alpha} \right|^2 \quad (1)$$

where J_1 is the the first-order Bessel function [4].

For illustrative purposes, some calculations were also made for wider beamwidth antennas each having a uniformly illuminated rectangular aperture and operating at 1.4485 GHz (L-band). These antennas have a three dB beamwidth of 38 degrees in azimuth and 135 degrees in elevation.

For the uniformly illuminated rectangular aperture, directional power gain normalized to its maximum value is computed to the front and side of the antenna as [3]

$$G(\phi=0^\circ) = \left| \frac{\sin \left(\frac{\pi a}{\lambda} \sin \alpha \right)}{\frac{\pi a}{\lambda} \sin \alpha} \right|^2 ; \quad G(\phi=90^\circ) = \left| \frac{\sin \left(\frac{\pi b}{\lambda} \sin \alpha \right)}{\frac{\pi b}{\lambda} \sin \alpha} \right|^2 \quad (2)$$

where a is the vertical aperture dimension and b is the horizontal aperture dimension.

For the direct-path case, antenna gains are maximum and therefore normalized to one. The direct-path received signal power density is computed as

$$(PD)_r = \frac{P_t}{4\pi d_{tr}^2} \quad (3)$$

where d_{tr} is the distance from the transmitter to the receiver.

Since

$$\text{effective receiving antenna aperture area} = \frac{\lambda^2}{4\pi} \quad (4)$$

$$\text{direct-path signal power received} = P_r = \frac{P_t \lambda^2}{(4\pi)^2 d_{tr}^2} \quad (5)$$

The direct-path electric vector magnitude is then computed as

$$|E_r| = \sqrt{P_r} \quad (6)$$

The direct-path electric vector phase is computed as

$$\angle E_r = -k * d_{tr} \quad (7)$$

2. Reflections From Vertical Portions of ALDF Water Spray Towers

The towers supporting the water sprinkler assembly are modeled as totally reflective metal cylinders of diameter 7.0751 inches. The vertical tower portions are treated as reflectors separate from the horizontal portions. As the transmitter position changes, each vertical tower member is examined from bottom to top to determine specular points which could contribute to the received multipath signal (See figure 2). Candidate specular points fulfill the following condition:

Reflected rays must lie within cones of energy centered around the longitudinal axis of the cylinder, where the cone thickness is approximated by λ/h .

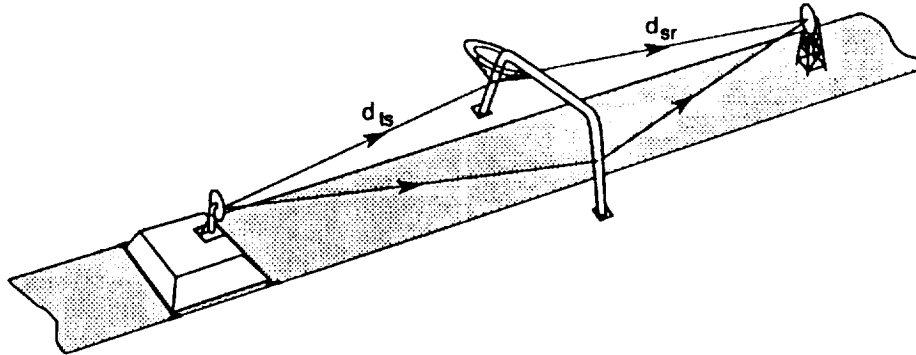

Figure 2: Reflections from vertical tower supports

From the range of heights of candidate specular points, the mean height is determined. At this height, a position around the circumference of the cylinder is found subject to the following conditions:

- 1) The normal to the cylinder's surface at that point is coplanar with the incident and reflected rays.
- 2) The normal to the cylinder's surface at that point bisects the angle between the incident and reflected rays.

At the specular point so determined, the radar cross section is determined according to the following equation [5]: (See figure 3)

$$\sigma(\psi_1, -\psi_1, \phi') = 4kah^2 \cos \psi_1 \cos \frac{\phi'}{2} \quad (8)$$

Equation (8) is valid for these conditions:

- 1) The cylinder radius and length are much larger than the wavelength.
- 2) Scattering occurs only near the specular direction.
- 3) The surface is a perfect conductor.

According to the radar equation,

$$\text{power density at a reflection point} = \frac{P_t G_t}{4\pi d_{ts}^2} \quad (9)$$

where d_{ts} is the distance from the transmitter to the specular point.

[from reference 5]

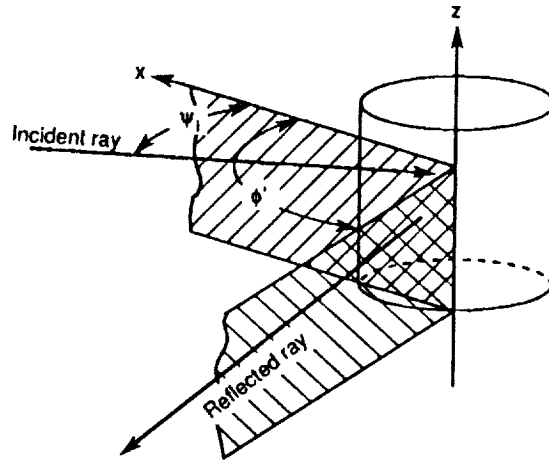

Figure 3: Diagram showing angles in equation (8)

$$\text{power density at receiver} = \frac{P_t G_t \sigma}{(4\pi)^2 d_{ts}^2 d_{sr}^2} \quad (10)$$

where d_{sr} is the distance from the specular point to the receiver.

Since

$$\text{effective area of receiving aperture} = \frac{G_r \lambda^2}{4\pi} \quad (11)$$

the power seen by the receiving antenna due to the reflection from one specular point is then calculated as

$$P_r = \frac{P_t G_t G_r \sigma \lambda^2}{(4\pi)^3 d_{ts}^2 d_{sr}^2} \quad (12)$$

The magnitude of the electric vector is calculated as

$$|E_r| = \sqrt{P_r} \quad (13)$$

and the phase as

$$\angle E_r = -k * (d_{ts} + d_{sr}) + \pi \quad (14)$$

3. Reflections From Horizontal Portions of ALDF Water Spray Towers

As shown in figure 4, multipath signals from the horizontal tower sections are assumed to be reflected from the center of each cylindrical crosspiece. As in the case of the vertical tower sections, candidate specular points are chosen to satisfy the condition that the reflected ray lies within the cone whose apex angle and thickness are determined by the angle of incidence and the length of the illuminated section of the cylinder.

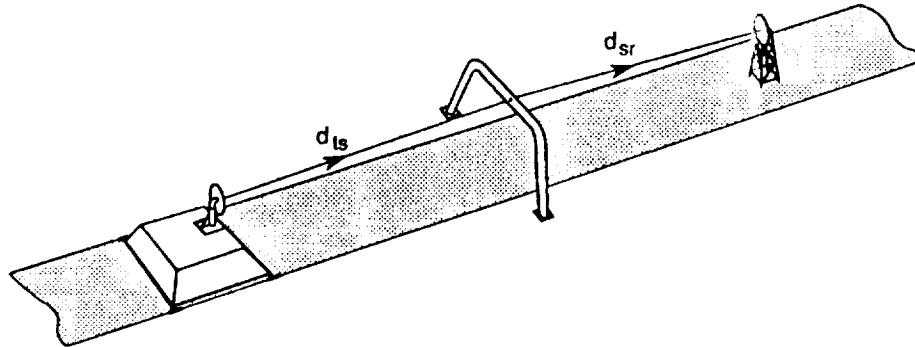

Figure 4: Reflections from horizontal tower supports

For each specular point satisfying these conditions for a particular arrangement of transmitter and receiver, radar cross section, power density, and the received multipath electric vector magnitude and phase are calculated using the equations given in section V.A.2.

4. Reflections From Horizontal Track Surface

A concrete surface runs between the tracks travelled by the ALDF sled. Although the actual surface contains troughs for water runoff, the model surface is flat with an optional layer of water on top of the concrete in the region of the water sprinklers.

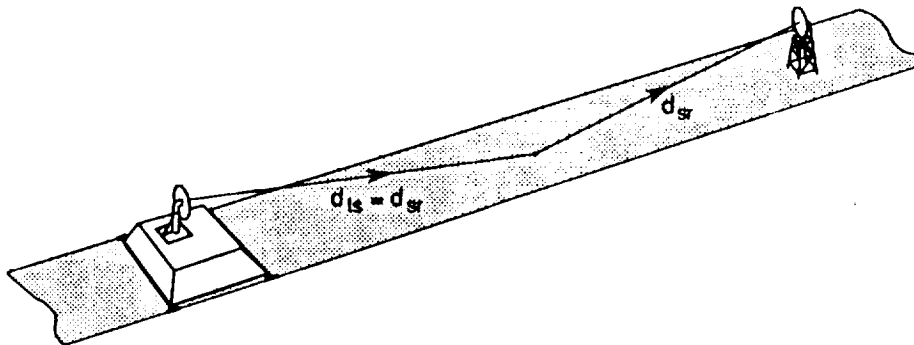

Figure 5: Reflections from concrete track surface

Candidate specular points are assumed to lie midway between the sides of the track and midway down the length of track between the receiver and transmitter, as shown in figure 5.

The multipath electric vector is calculated as [6]

$$E_{r,multipath} = G_t \Gamma |E_{r,direct-path}| e^{-jkL} \quad (15)$$

where L is the path length from the underground image of the transmitter to the receiver.

$$|E_{r,multipath}| = G_t |\Gamma| |E_{r,direct-path}| = \frac{G_t |\Gamma| \lambda \sqrt{P_t}}{4\pi d_{tr}} \quad (16)$$

$$\angle E_{r,multipath} = \angle \Gamma - kL \quad (17)$$

The complex coefficient of reflection, Γ , is calculated for horizontally or vertically polarized signals from the equations shown in appendix B. These equations take into account the permittivities of water and concrete and the thickness of water on top of the concrete surface.

Water temperature and signal frequency are both used in finding the complex permittivity of the water layer (See subroutine *REFRAC*, appendix C.) The temperature is chosen to be 20 degrees Celcius. The number (4.65, -0.072) is used for the complex permittivity of concrete. The real part was taken from [7], the imaginary part estimated from information found in [8], [9], and [10]. Water thickness is assumed to be a constant 0.059 inches in the area between the first and last towers; it is assumed to taper linearly to a thickness of zero 20 feet past each of the two outermost towers. The concrete is modeled as an infinitely thick layer.

5. Attenuation by Rain

All direct-path or multipath signals reaching the receiver are attenuated by a factor dependant on the distance travelled through the simulated rain. From Battan's *Radar Meteorology* [11],

$$|E_{attenuated}| = |E_{unattenuated}| * \log^{-1} \left(\frac{-c R^\nu d}{20} \right) \quad (18)$$

where d is the distance through the rain and R is the rainfall rate.

As given by Battan, when $\lambda = 3.2$ cm, constants $c = 0.0074$ and $\nu = 1.31$. In this simulation, the rainfall is taken to be uniform throughout the area under the water sprinklers.

B. Variation of Multipath Parameters for the Study

This section describes how certain multipath parameters were varied to

carry out the radar multipath study. As the parameters were changed, the program ALDF.FOR was rerun to produce different plots. In general, these are dB plots with total received power calculated relative to the direct-path power. The plots appear in appendix A.

1. Antenna Beamwidth

Although the proposed antenna for the ROR experiment is a 3.5-degree beamwidth antenna transmitting at X-band, a few plots were made using a wide beamwidth antenna transmitting at L-band in order to make the multipath effects more apparent. To identify the contribution of the various reflectors to the total received signal, plots were made showing signal strength of the received signal with the multipath signal groups added in one at a time. These values were stored by the program ALDF.FOR in files called CONES1.DAT, CONES2.DAT, AND CONES3.DAT.

2. Antenna Height

A number of plots were made showing total received signal power corresponding to antenna heights of 5, 10, 15, and 20 feet. While the antenna height was varied, signal polarization and rainfall rate were held constant.

3. Signal Polarization

To compare results from horizontally and vertically polarized transmit signals, plots were drawn showing received signal power resulting from differently polarized transmit signals while antenna height and rainfall rate were held constant.

4. Rain Rate

To compare the received signal power with and without rain, plots were drawn of the total received signal in different rain conditions including no rain, 2, 10, 30, and 40 inches per hour rain. The no-rain case was further divided into no rain with a dry track and no rain with a wet track in the tower area. While the rainfall rate was varied, antenna height and signal polarization were held constant.

VI. RESULTS OF THE MULTIPATH STUDY (See plots in appendix A)

Unless otherwise specified, these results apply to the simulations using 3.5-degree beamwidth antennas.

A. Separate Reflectors

The wide beamwidth simulations show that two groups of oscillations may be present in the received signal power. In figures 6 and 7, lower frequency oscillations are due to reflections from the concrete track. The six groups of higher frequency oscillations superimposed on the lower frequency ones are due to reflections from the vertical tower sections. These effects are not noticeable in the 3.5-degree beamwidth simulations.

While the horizontal tower sections have a calculable effect on the received power, that effect is too small to be seen on any of the graphs.

B. Magnitude of Received Power Oscillations

For the 3.5-degree beamwidth antenna, the largest signal power fluctuation while the sled was under the towers was plus 5.3 and minus 11.0 dB relative to the direct-path signal. This result occurred at antenna height ten feet with a horizontally polarized signal and zero rainfall (See figure 8). The magnitude of the signal power fluctuations can be decreased significantly by changing the antenna height in either direction (See figures 8-11).

C. Frequency of Received Power Oscillations

As shown in figures 8-11, the most rapid oscillations in signal power occurred at the greatest antenna height examined, 20 feet. At that height, use of the nominal sled velocity shows that the fluctuations occurred at the rate of about two per second.

D. Antenna Height

Figures 8-11 show the received signal power when the antennas are placed at different heights. Although there is in every case some oscillation due to reflections from the concrete, the oscillations that occur at the time of interest in the experiment can be minimized by proper choice of antenna height. Of the antenna heights examined, five feet produced the smallest fluctuations during the critical measurement time.

E. Signal Polarization

Compared to horizontally polarized signals, vertically polarized signals produced oscillations of slightly smaller amplitude (Compare figures 8 and 9 to figures 10 and 11). The decrease was about 1.5 dB. The presence of a thinning layer of water on the track surface caused the reflection of the vertically polarized signal to reach a low point when the transmitter passed the 508-foot point in figure 11. This resulting dip in received power was not observed for horizontally polarized signals under the same conditions.

Most significantly, the presence of water on the track produced a change in the total signal to direct-path signal ratio for vertically polarized signals. Such changes were negligible for horizontally polarized signals; the ratio remained virtually the same under all conditions. Figure 12 shows the differential behavior of the total received signal power under changing track conditions, using a vertically polarized signal. In the leftmost portion of the graph, until the sled reaches 534 feet, the specular point is in the tower area, which is wet for one trace and dry for the other. Once the sled has travelled far enough that the specular point is out of the tower area and on dry concrete, the two traces coincide.

F. Rain Rate

Although increasing amounts of rain cause increasing path attenuation,

there is no change in the ratio between total received signal power and direct-path signal power. For a given antenna height, the plots look alike for 2 to 40 inches per hour of rain. This can be understood by the fact that the path distances within the rain are about the same for both the direct and the multipath rays. As was mentioned in the previous paragraph, the factor which did make a difference was the wetness or dryness of the track.

VII. MULTIPATH EFFECTS ON ROR EXPERIMENT FEASIBILITY

The analytical study shows that the ROR experiment is feasible with regard to multipath signals. The magnitude and frequency of oscillations expected in the received signal power are such that they can be handled by readily available hardware (See example calculations below). Also, by using horizontal polarization or by wetting down the track surface for the baseline run, the ratio of total signal power to direct-path signal power can be kept constant. This will allow calculation of the desired quantity, signal attenuation due to heavy rain.

As long as $\frac{\text{total power without rain}}{\text{direct-path power without rain}} = \frac{\text{total power with rain}}{\text{direct-path power with rain}}$

and $\frac{\text{total power with rain}}{\text{total power without rain}}$ can be measured

then the ratio $\frac{\text{direct-path power with rain}}{\text{direct-path power without rain}}$ can also be calculated.

A further reason to avoid vertical polarization is the sensitivity of the reflection coefficient to changing thickness of the water layer atop the concrete. Local variations in water thickness could cause undesirable perturbations in the received power.

As shown in figures 6 and 7, very large, rapid power fluctuations can occur if a wide beamwidth antenna is used at the ALDF. However, use of a 3.5-degree beamwidth antenna limits the significant multipath signals to those smaller and slower fluctuations arising from the concrete track. Such an antenna is representative of actual weather radar antennas.

VIII. ROR EXPERIMENT DESIGN CONSIDERATIONS

The Fortran program written for this study provides a tool for examining multipath signals created by various combinations of experimental variables. These variables are: antenna size and height above ground, carrier signal frequency, starting and stopping points of the sled along the ALDF track, rainfall rate, and water temperature. In all cases the transmitting and receiving antennas have circular apertures, are placed at the same height above ground, and are centered between the sides of the track. The following is an example of how the program can be used to estimate hardware requirements for measuring radar transmissions from the moving ALDF sled.

Dynamic Range

Given distance from first to last tower = 6432.60 in
Choose distance between last tower and receiver = 8903.04 in
Choose $\lambda = 3.22$ cm = 1.267 in
Choose antenna gain = 34.5 dB
Choose transmitted power = 0.001 w = 0 dBm

Calculate distance from transmitter to receiver when sled is at first tower
 $d_{tr} = 6432.60 + 8903.04 = 15335.64$ in

Calculate received direct-path power with unity gain antennas

$$P_r = \frac{P_t \lambda^2}{(4\pi)^2 d_{tr}^2} = 4.322E-14 \text{ w} = -103.64 \text{ dBm}$$

Calculate received direct-path power, incorporating antenna gains

$$P_{r'} = -103.64 \text{ dBm} + 2(34.5) \text{ dB} = -34.64 \text{ dBm}$$

Repeat calculations with sled at last tower

$$d_{tr} = 8903.04 \text{ in}$$

$$P_r \text{ with unity gain antennas} = 1.282E-13 \text{ w} = -98.92 \text{ dBm}$$

$$P_{r'} \text{ incorporating antenna gains} = -98.92 \text{ dBm} + 2(34.5) \text{ dB} = -29.92 \text{ dBm}$$

For a uniformly illuminated circular aperture,

$$\text{diameter} \cong \frac{58.4 \lambda}{\text{degree b.w.}} \quad [2]$$

Choose beamwidth = 3.5 deg

Diameter = 21.1 in

Choose antenna height = 10 ft = 120 in

Run ALDF.FOR to calculate total power relative to direct-path power
maximum fluctuations are -11.0 dB, +5.3 dB

Calculate variation in absolute received power

$$P_{\min} = P_{r', \text{first tower}} - 11.0 \text{ dB} = -45.64 \text{ dBm}$$

$$P_{\max} = P_{r', \text{last tower}} + 5.3 \text{ dB} = -24.62 \text{ dBm}$$

Receiver Noise Level

Calculate transmitter oscillator frequency error

At X-band, error $\cong 1E-6$ (10 GHz) = ± 10 kHz

Allow ± 5 kHz error margin for Doppler shift

Allow ± 10 kHz error margin for any other frequency errors

Calculate noise bandwidth

$$BW_N = 2(10 + 5 + 10 \text{ kHz}) = 50 \text{ kHz}$$

Choose candidate receiver with noise specified at -90 dBm for 1kHz bandwidth.

Calculate receiver noise, incorporating noise bandwidth

$$-90 \text{ dBm} = 1\text{E}-12 \text{ w}$$

$$N = 50 \text{ kHz}(1\text{E}-12 \text{ w/kHz}) = 50\text{E}-12 \text{ w} = -73.0 \text{ dBm}$$

Calculate margin between weakest signal power and receiver noise power

$$\text{Margin} = -45.6 \text{ dBm} - (-73.0 \text{ dBm}) = 27.4 \text{ dBm}$$

If a better SNR is desired, one could change antenna placement, choose a more powerful transmitter, or choose a less noisy receiver.

The above calculations make use of a noise specification for a commercially available spectrum analyzer RF section. The same instrument also has a tuning range of 0.01 to 18.00 GHz and has an amplitude calibration range of -130 dBm to +10 dBm, making it a suitable candidate for the receiver in the ROR experiment.

IX. CONCLUSIONS

A. Feasibility of ROR Experiment with Regard to Multipath Signals

Regarding multipath effects, this study shows the ROR experiment to be feasible using readily available hardware. Two 3.5-degree beamwidth antennas would allow a received signal containing oscillations of magnitude and frequency such that a good comparison could be made between signal power received with and without rain. Furthermore, the received signal varies sufficiently slowly with time that it would be relatively easy to detect a sudden drop in signal of a few dB if it should occur as the sled enters the water spray. The study suggests that horizontal polarization should be used to produce a more predictable received signal. The ALDF.FOR program can determine the best antenna height after the exact horizontal placement of the receiver is decided.

B. Possible Improvements in the Analytical Study

There are several ways that the analytical study could be expanded to provide more accurate estimations of received signal power:

- 1) The model of the water sprinkler system could be expanded to include the narrow water pipes along the top of the tower structure.
- 2) The model of the surrounding structures could be made to include the sets of cylindrical water and air tanks that sit on the grass next to the bases of the vertical tower sections on one side.
- 3) The antenna geometry could be modified to allow for inclusion of antennas at different heights or to allow for one antenna being placed off to one side of the track.

REFERENCES

- [1] J. R. Branstetter (editor), M. C. Bailey, C. P. Hearn, R. E. Dunham, Jr., et al, NASA Technical Memorandum 85813: An Investigation of the Existence of a Surface Water Layer on Aircraft Radomes During Simulated Flight in Heavy Precipitation, June 1984.
- [2] B. G. Asbury, PRC Kentron, Mechanical Drawings of NASA ALDF Heavy Rain Simulation System, Drawing Nos. LD-205506: "Overview of Project Area," LD-205508: "Tower System Assembly," LD-205509: "Frame Assembly," and LD-205515: "Frame Section Details," Feb. 5, 1987.
- [3] Samuel Silver, *Microwave Antenna Theory and Design*, Dover Publications, Inc., New York, 1965, Ch. 6, "Aperture Illumination and Antenna Patterns," pp. 180-181, 192-195.
- [4] MicroSoft, Inc., BESSJ, GAMMA, and PLYEVL Subroutines, MicroSoft Fortran Version 4.5, Science Routine Library, 1988.
- [5] Donald E. Barrick, Clarence K. Krichbaum, George T. Ruck, and William D. Stuart, *Radar Cross Section Handbook, Vol. 1*, Plenum Press, New York, 1970, p. 307.
- [6] J. S. Hollis, T. J. Lyon, and L. Clayton, Jr. (editors), *Microwave Antenna Measurements*, "Antenna Range Design and Evaluation," T. J. Lyon, J. S. Hollis, and T. G. Hickman (authors), Scientific-Atlanta Inc., Atlanta, Georgia, 1981, Sec. 14., pp. 16-18.
- [7] Jun Horikoshi, Kiyoshi Tanaka, and Takahiro Morinaga, "1.2 GHz Band Wave Propagation Measurements in Concrete Building for Indoor Radio Communications," *IEEE Transactions on Vehicular Technology*, vol. VT-35, No. 4, pp. 146-152, Nov. 1986.
- [8] George S. Brady and Henry R. Clauser, *Materials Handbook*, Eleventh Edition, McGraw-Hill Book Company, New York, 1979, pp. 208-209.
- [9] Fawwaz T. Ulaby, Richard K. Moore, and Adrian K. Fung, *Microwave Remote Sensing, Active and Passive, Vol. 3: From Theory to Applications*, Artech House, Dedham, Massachusetts, 1986, pp. 2083-2084.
- [10] Charles D. Hodgman, Robert C. Weast, Clarence W. Wallace, and Samuel M. Selby (editors), *Handbook of Chemistry and Physics*, 36th Edition, Chemical Rubber Publishing Company, Cleveland, Ohio, 1954, p. 2329.
- [11] Louis J. Battan, *Radar Meteorology*, The University of Chicago Press, Chicago, Illinois, 1960, p. 49.

APPENDIX A: PLOTS OF RECEIVED SIGNAL POWER

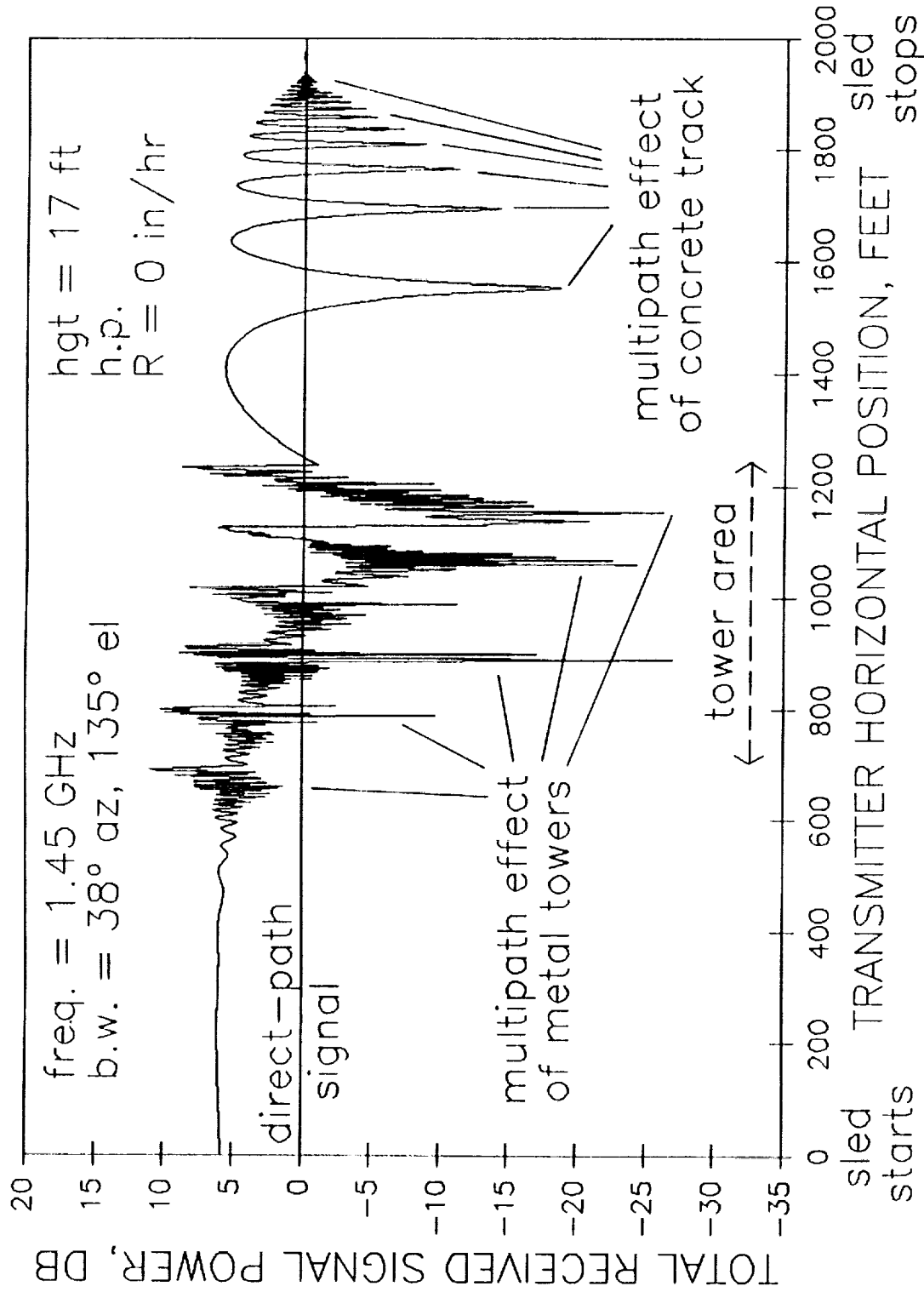

Figure 6: Effect of using wide-beamwidth antennas. Reflected signals from the metal towers combine with the direct-path signal to produce large oscillations in total received signal power. Total received signal power is shown in dB relative to direct-path signal power received.

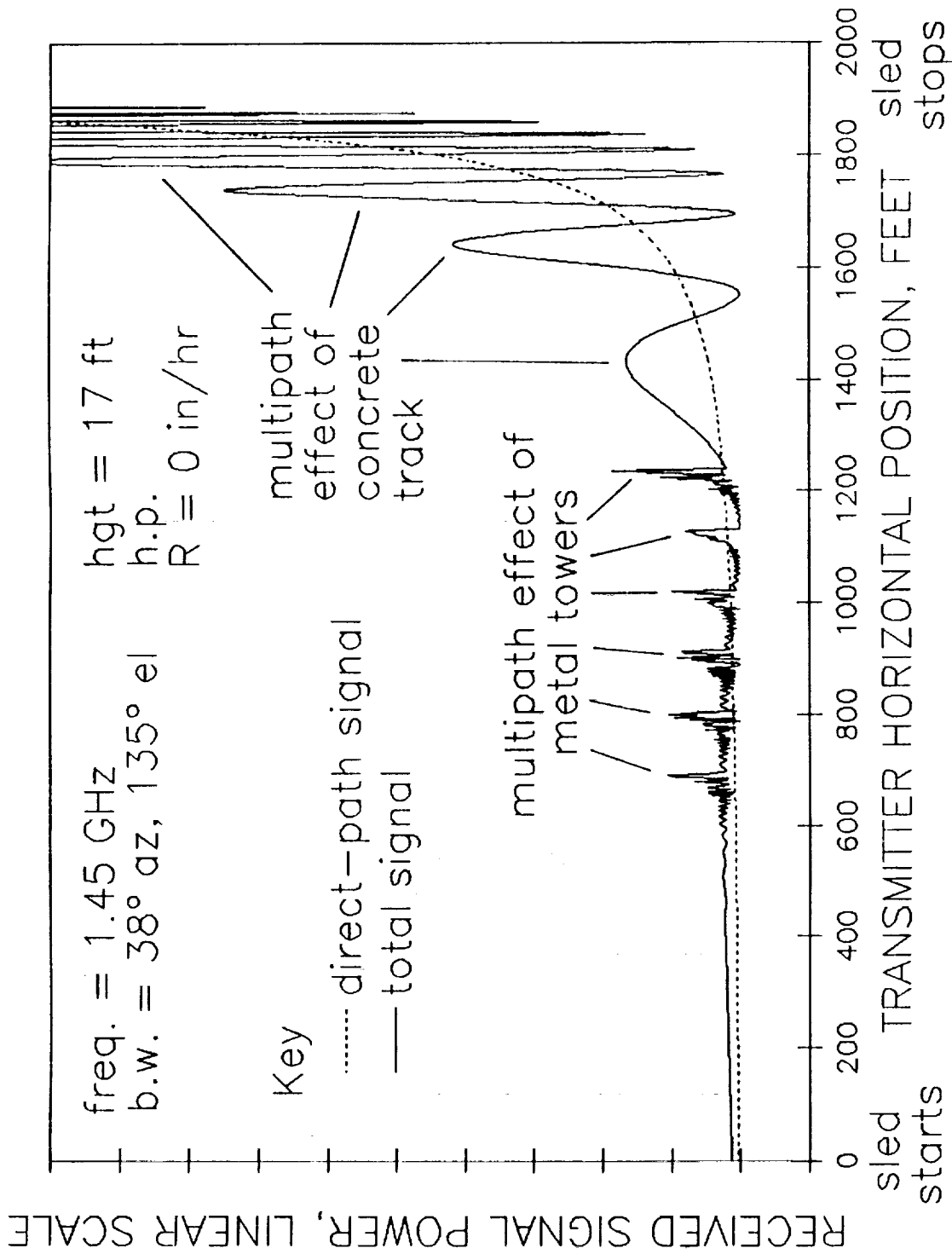

Figure 7: Effect of using wide-beamwidth antennas. This plot shows the same information as Figure 6, but represents power for both the direct-path received signal and the total received signal on an absolute linear scale. The graph has gone off the scale at the top right.

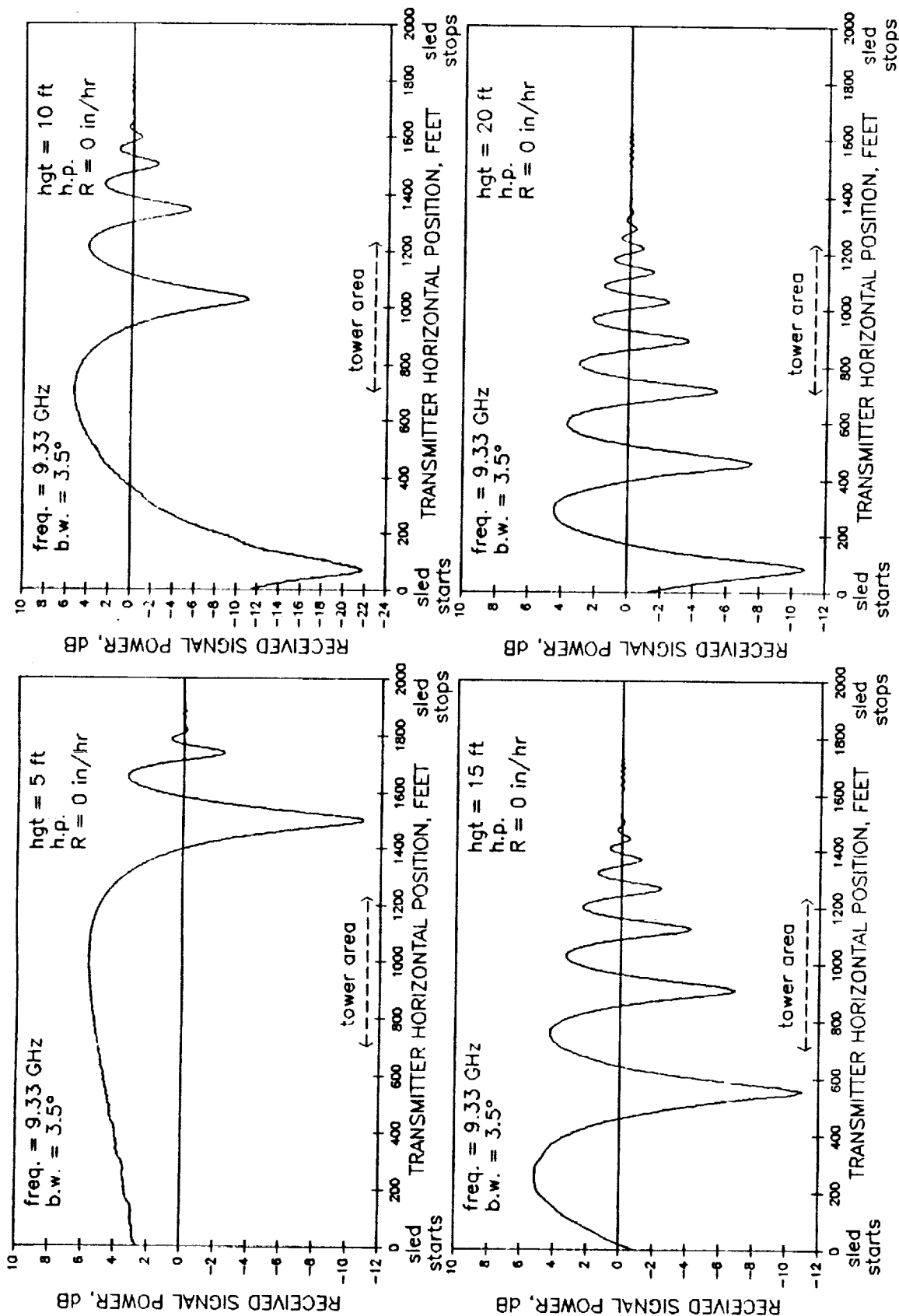

Figure 8: Total received signal power at four antenna heights, using horizontal polarization and no simulated rain. Total received signal power is calculated in dB relative to direct-path signal power received.

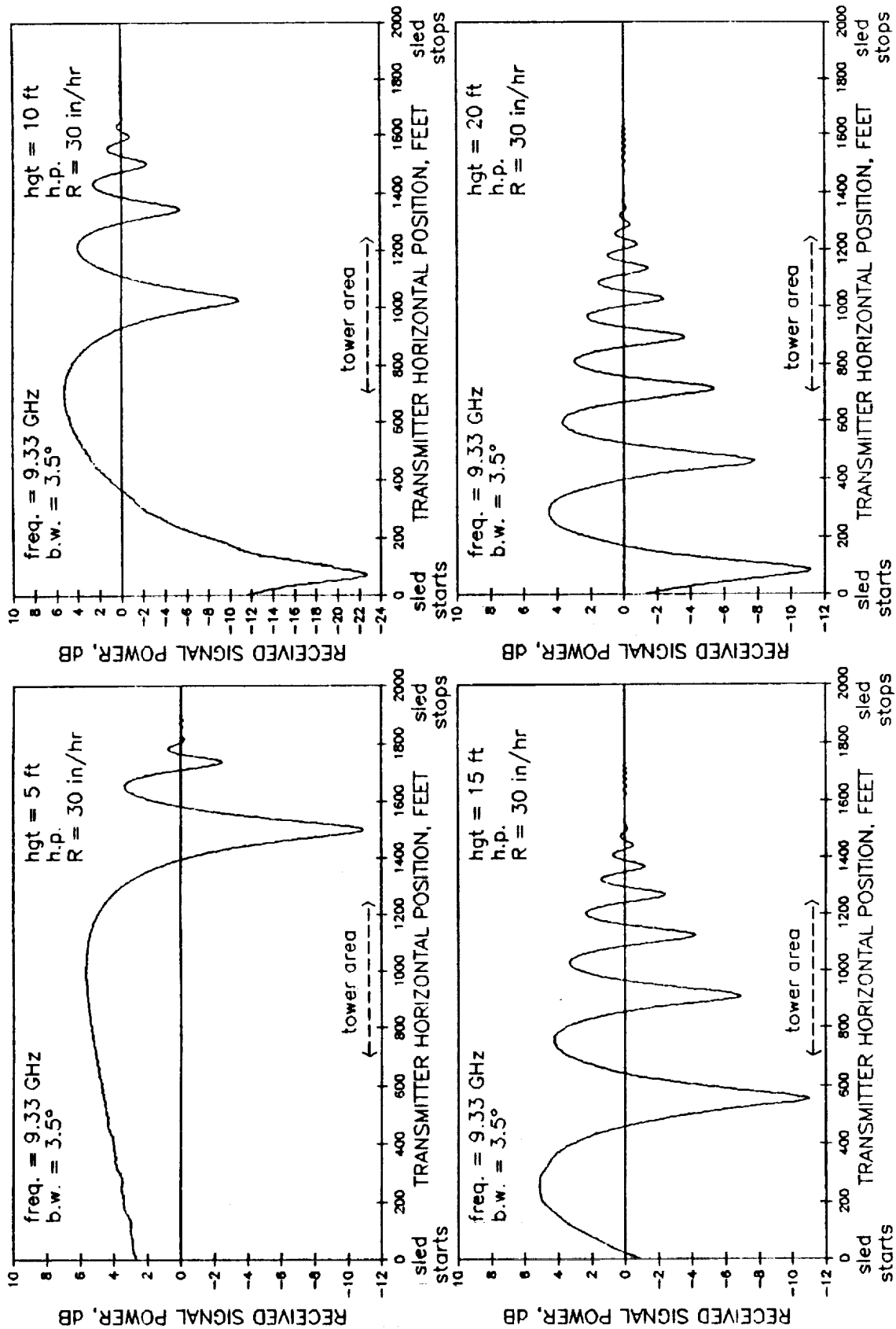

Figure 9: Total received signal power at four antenna heights, using horizontal polarization and 30 in/hr simulated rain. Total received signal power is calculated in dB relative to direct-path signal power received.

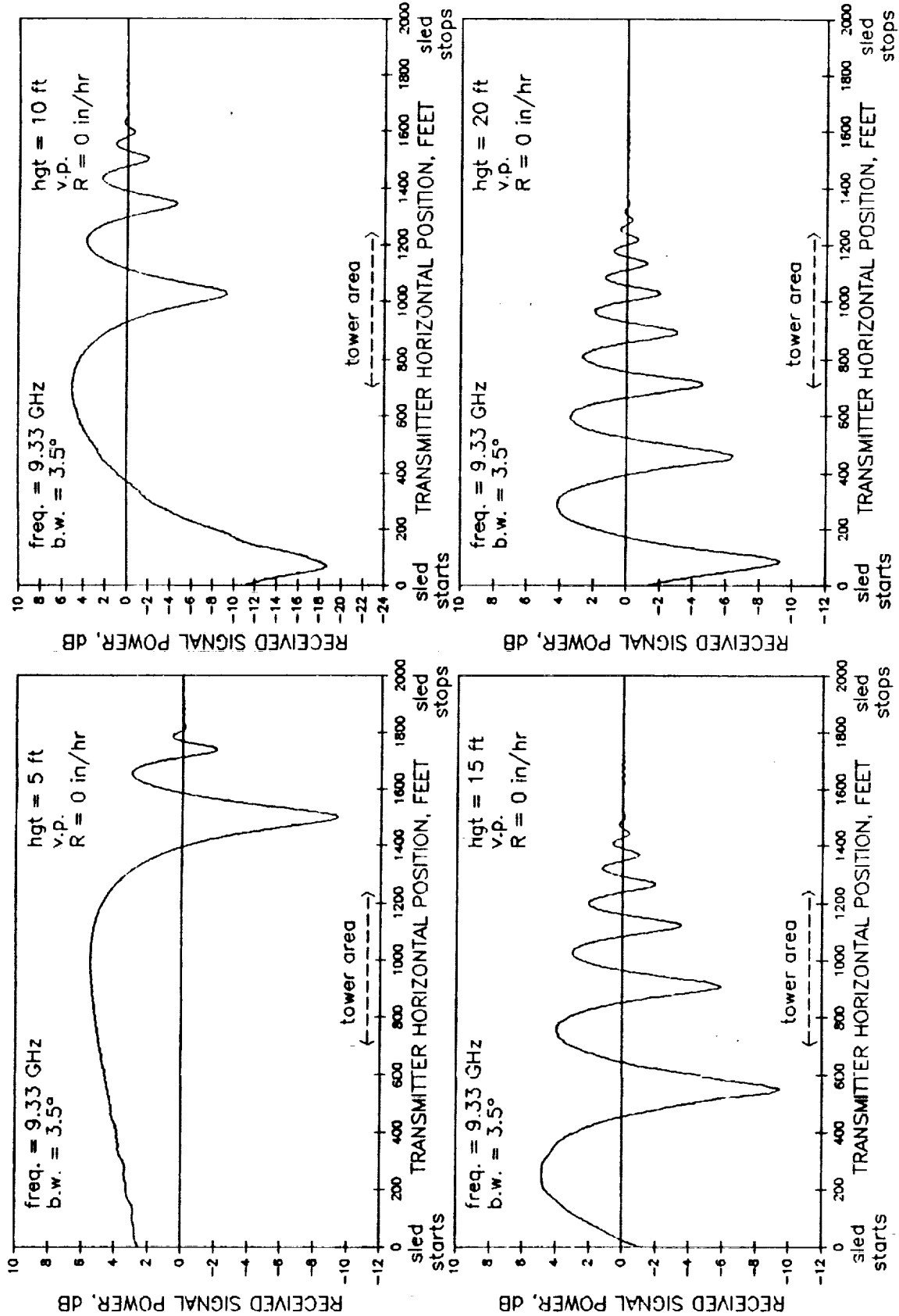

Figure 10: Total received signal power at four antenna heights, using vertical polarization and no simulated rain. Total received signal power is calculated in dB relative to direct-path signal power received.

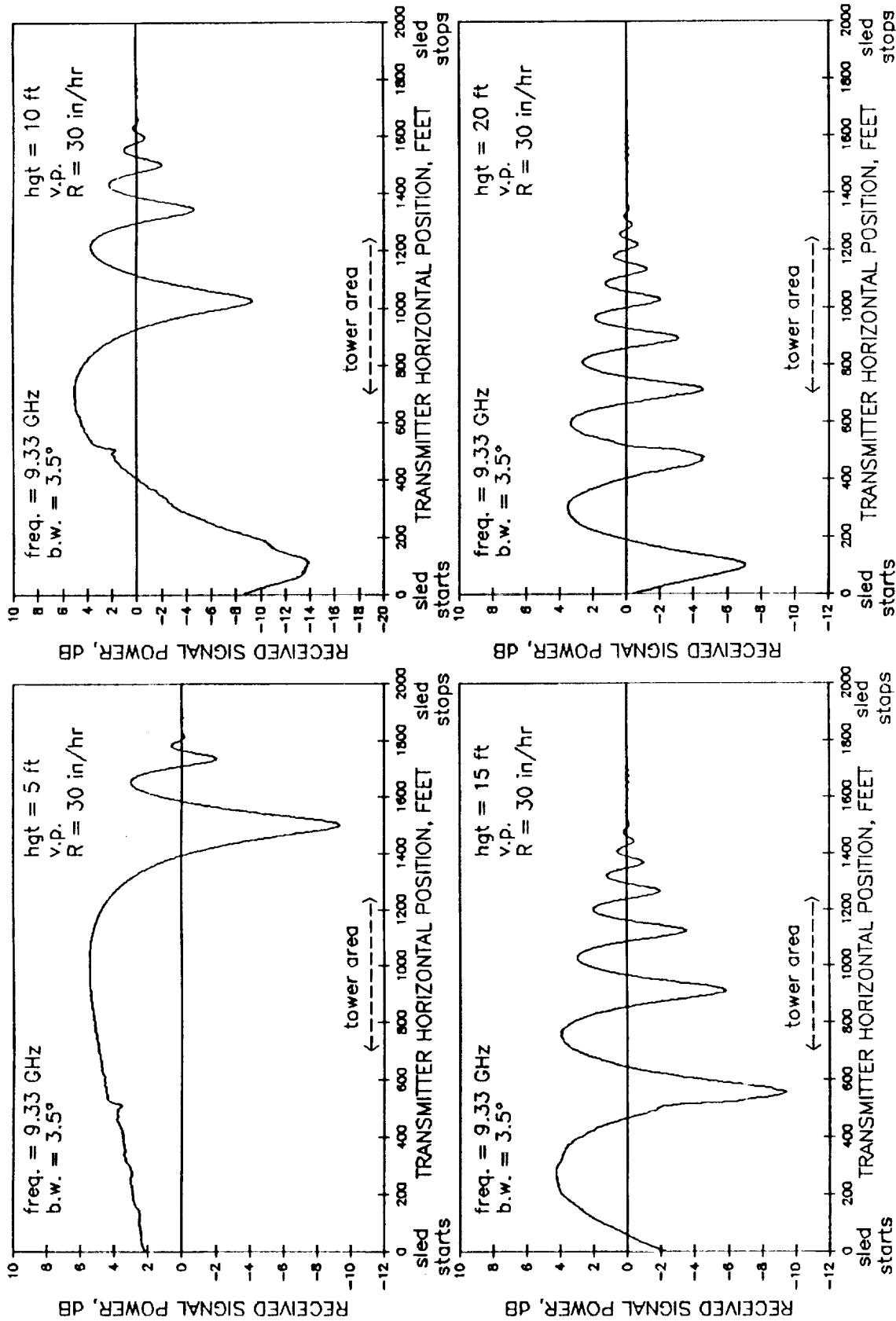

Figure 11: Total received signal power at four antenna heights, using vertical polarization and 30 in/hr simulated rain. Total received signal power is calculated in dB relative to direct-path signal power received.

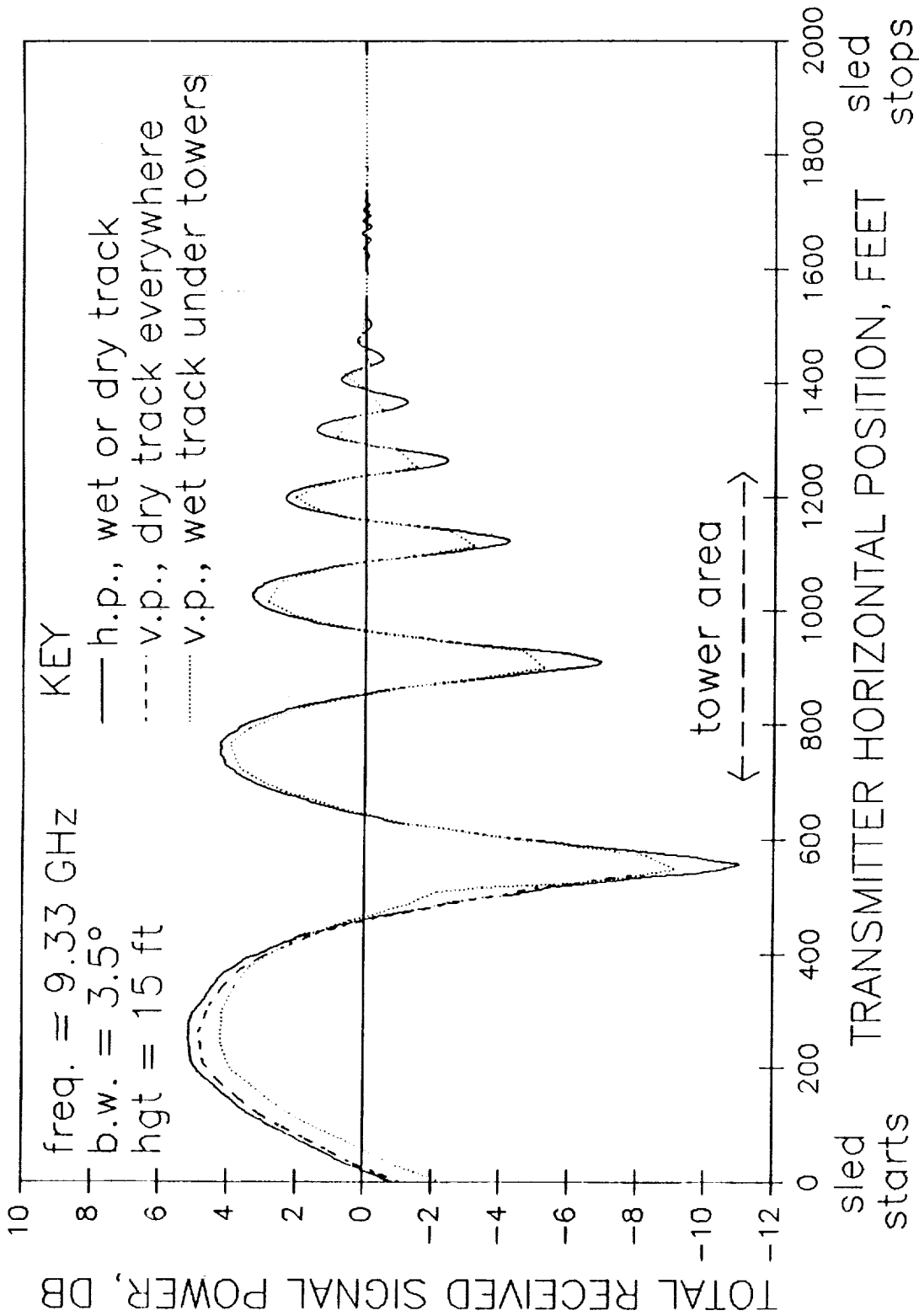

Figure 12: Effect of water on the concrete track. Total received signal is shown in dB relative to the direct-path signal received. Unlike the horizontally polarized signal curve, the vertically polarized signal curve is sensitive to water on the track under the towers. The effect is visible when the multipath specular point on the concrete is in the tower area. This happens before the sled itself reaches the towers.

APPENDIX B: REFLECTION COEFFICIENTS FOR WET AND DRY CONCRETE

These equations for Γ , the complex coefficient of reflection, were derived from Maxwell's equations. They pertain to the special case where the incident wavefront originates in free space and is reflected from two superimposed, flat layers of dielectric material (See figure 13). In the analytical study, the upper layer was water and the lower layer was concrete.

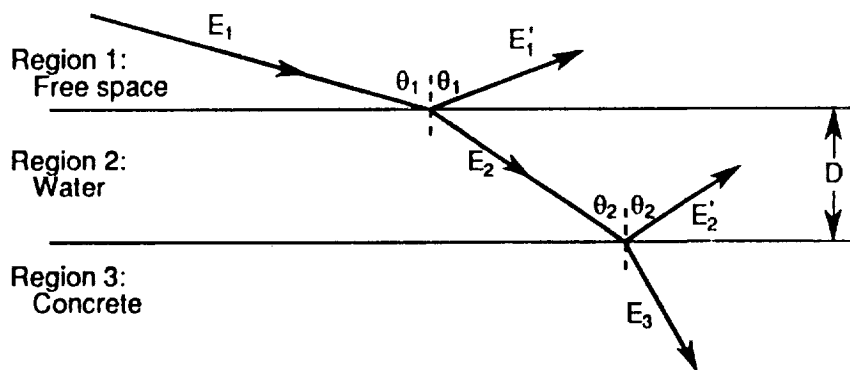

Figure 13: Wavefront incident on two dielectric layers

SYMBOL DEFINITIONS

SYMBOL	DEFINITION
c_n	$\cos(\theta_n)$, θ_n = angle of incidence at the boundary between regions n and $n+1$
D	Depth of water layer
E_n	Electric field strength of the signal incident on the $n, n+1$ boundary
E_n'	Electric field strength of the signal reflected from the $n, n+1$ boundary
k_0	Propagation constant in free space
ϵ_n	Relative complex permittivity of region n
θ_n	Angle of incidence at the $n, n+1$ boundary

Horizontal Polarization

$$E_2 = \left(\frac{c_3 \sqrt{\epsilon_3} + c_2 \sqrt{\epsilon_2}}{2 c_2 \sqrt{\epsilon_2}} \right) \exp \left[-jk_0 D \left(c_3 \sqrt{\epsilon_3} - c_2 \sqrt{\epsilon_2} \right) \right] \quad (1)$$

$$E'_2 = \left(\frac{c_2 \sqrt{\epsilon_2} - c_3 \sqrt{\epsilon_3}}{2 c_2 \sqrt{\epsilon_2}} \right) \exp \left[-jk_0 D \left(c_3 \sqrt{\epsilon_3} + c_2 \sqrt{\epsilon_2} \right) \right] \quad (2)$$

$$\Gamma_{HP} = \frac{E'_1}{E_1} = \frac{c_1 \left(E_2 + E'_2 \right) - c_2 \sqrt{\epsilon_2} \left(E_2 - E'_2 \right)}{c_1 \left(E_2 + E'_2 \right) + c_2 \sqrt{\epsilon_2} \left(E_2 - E'_2 \right)} \quad (3)$$

Vertical Polarization

$$E_2 = \left(\frac{c_2 \sqrt{\epsilon_3} + c_3 \sqrt{\epsilon_2}}{2 c_2 \sqrt{\epsilon_2}} \right) \exp \left[-jk_0 D \left(c_3 \sqrt{\epsilon_3} - c_2 \sqrt{\epsilon_2} \right) \right] \quad (4)$$

$$E'_2 = \left(\frac{c_2 \sqrt{\epsilon_3} - c_3 \sqrt{\epsilon_2}}{2 c_2 \sqrt{\epsilon_2}} \right) \exp \left[-jk_0 D \left(c_3 \sqrt{\epsilon_3} + c_2 \sqrt{\epsilon_2} \right) \right] \quad (5)$$

$$\Gamma_{VP} = \frac{E'_1}{E_1} = \frac{c_1 \sqrt{\epsilon_2} \left(E_2 + E'_2 \right) - c_2 \left(E_2 - E'_2 \right)}{c_1 \sqrt{\epsilon_2} \left(E_2 + E'_2 \right) + c_2 \left(E_2 - E'_2 \right)} \quad (6)$$

APPENDIX C: COMPUTER PROGRAM ALDF.FOR

```

C *****
C THIS PROGRAM PREDICTS ALDF BACKSCATTERING.
C OUTPUTS ARE:
C   XR, TRANSMITTER POSITION MEASURED FROM STARTING POINT, INCHES
C   DIRECT-PATH RECEIVED SIGNAL POWER, UNSPECIFIED UNITS
C   TOTAL COMBINED RECEIVED SIGNAL POWER, UNSPECIFIED UNITS
C INPUTS ARE:
C   ANTENNA HEIGHT, INCHES
C   DISTANCE FROM SLED'S STARTING POINT TO FIRST TOWER, INCHES
C   DISTANCE FROM LAST TOWER TO RECEIVER, INCHES
C   INCREMENTS OF DISTANCE AT WHICH YOU WISH TO CALCULATE MULTIPATH SIGNALS
C     IN INCHES
C   ANTENNA RADIUS, INCHES
C   RADAR SIGNAL FREQUENCY, HERTZ
C   RAIN RATE, INCHES PER HOUR
C   RAIN TEMPERATURE, DEGREES CELCIUS

C NOTE: ALL POWER FIGURES IN THE RESULTS ARE REDUCED BY A FACTOR OF
C  $PT(\pi^2)(\text{RADANT}^4)/\text{LAMBDA}^2$ 

```

```

SUBROUTINE ANGLES(A, B, H, THETA1, XR, YT, ZR, ANGINC, PHI, SIHATX, SIHATY,
@ SIHATZ, SILEN, SRLEN, ZBHATX, ZBHATY, ZBHATZ)
C THIS SUBROUTINE CALCULATES ANGINC (ANGLE OF INCIDENCE) AND PHI (AZIMUTHAL
C ANGLE BETWEEN THE PLANE CONTAINING THE INCIDENT RAY AND CYLINDER AXIS AND
C THE PLANE CONTAINING THE REFLECTED RAY AND CYLINDER AXIS.
SILEN = SQRT((A-XR)**2 + YT**2 + (H-ZR)**2)
SIHATX = (A-XR)/SILEN
SIHATY = YT/SILEN
SIHATZ = (H-ZR)/SILEN
SRLEN = SQRT((B-A)**2 + YT**2 + (ZR-H)**2)
SRHATX = (B-A)/SRLEN
SRHATY = -YT/SRLEN
SRHATZ = (ZR-H)/SRLEN
ZBLEN = SQRT((274.281-YT)**2 + (449.034-H)**2)
ZBHATX = 0
ZBHATY = (274.281-YT)/ZBLEN
ZBHATZ = (449.034-H)/ZBLEN
XBHATX = (ZBHATX*COS(THETA1)-SIHATX)/SIN(THETA1)
XBHATY = (ZBHATY*COS(THETA1)-SIHATY)/SIN(THETA1)
XBHATZ = (ZBHATZ*COS(THETA1)-SIHATZ)/SIN(THETA1)
YBHATX = ZBHATY*XBHATZ - ZBHATZ*XBHATY
YBHATY = ZBHATZ*XBHATX - ZBHATX*XBHATZ
YBHATZ = ZBHATX*XBHATY - ZBHATY*XBHATX
DOTXB = SRHATX*XBHATX + SRHATY*XBHATY + SRHATZ*XBHATZ
DOTYB = SRHATX*YBHATX + SRHATY*YBHATY + SRHATZ*YBHATZ
SPX = DOTXB*XBHATX + DOTYB*YBHATX
SPY = DOTXB*XBHATY + DOTYB*YBHATY
SPZ = DOTXB*XBHATZ + DOTYB*YBHATZ
SPLEN = SQRT(SPX**2 + SPY**2 + SPZ**2)

```

```

SPHATX = SPX/SPLEN
SPHATY = SPY/SPLEN
SPHATZ = SPZ/SPLEN
PHI = ACOS(XBHATX*SPHATX + XBHATY*SPHATY + XBHATZ*SPHATZ)
ANGINC = 0.5*ACOS(-SIHATX*SRHATX-SIHATY*SRHATY-SIHATZ*SRHATZ)
RETURN
END

```

```

SUBROUTINE BARILH (A, SPAN, XR, ZR, LENGTH, FLAG)
C THIS SUBROUTINE COMPUTES THE LENGTH OF THE HORIZONTAL BAR WHICH IS
C ILLUMINATED BY THE RADAR BEAM. IF THE BEAM RADIUS IS LESS THAN THE
C SHORTEST DISTANCE FROM THE BEAM CENTER TO THE BAR, THEN LENGTH = 0
C (FLAG = 1) AND THE PROGRAM JUMPS TO THE NEXT VERTICAL SUPPORT DOWN THE
C TRACK.

```

```

REAL LENGTH
INTEGER FLAG
RADIUS = (A-XR)*TAN(SPAN)
SHORT = 449.034 - ZR
IF (RADIUS.LT.SHORT) GOTO 50
Y = SQRT(RADIUS**2 - ZR**2 + 898.068*ZR - 201631.53)
IF (Y.GT.274.281) Y = 274.281
LENGTH = 2*Y
FLAG = 0
GOTO 60
50 FLAG = 1
60 RETURN
END

```

```

SUBROUTINE BARILV (A, SPAN, XR, ZR, LENGTH, FLAG)
C THIS SUBROUTINE COMPUTES THE LENGTH OF THE VERTICAL SUPPORT BAR WHICH IS
C ILLUMINATED BY THE RADAR BEAM. IF THE BEAM RADIUS IS LESS THAN THE
C SHORTEST DISTANCE FROM THE BEAM CENTER TO THE BAR, THEN LENGTH = 0
C (FLAG = 1) AND THE PROGRAM JUMPS TO THE NEXT VERTICAL SUPPORT DOWN THE
C TRACK.

```

```

REAL M, LENGTH
INTEGER FLAG
M = -2.988685
ZINCPT = 1268.772
RADIUS = (A-XR)*TAN(SPAN)
Y3 = (ZR - ZINCPT)/(M + 1/M)
Z3 = -Y3/M + ZR
SHORT = SQRT( Y3*Y3 + (Z3-ZR)**2 )
IF (RADIUS.LT.SHORT) GOTO 50
QUADA = M**2 + 1
QUADB = 2*M*(ZINCPT - ZR)
QUADC = ZINCPT**2 + ZR**2 - RADIUS**2 - 2*ZR*ZINCPT
Y1 = (-QUADB - SQRT(QUADB**2 - 4*QUADA*QUADC))/(2*QUADA)
Y2 = (-QUADB + SQRT(QUADB**2 - 4*QUADA*QUADC))/(2*QUADA)
Z1 = M*Y1 + ZINCPT
Z2 = M*Y2 + ZINCPT
IF (Z1.GT.449.034) THEN
Z1 = 449.034
Y1 = 274.281

```



```

ENDIF
IF (Z2.LT.-13.816) THEN
  Z2 = -13.816
  Y2 = 429.148
ENDIF
LENGTH = SQRT((Y2-Y1)**2 + (Z2-Z1)**2)
FLAG = 0
GOTO 60
50  FLAG = 1
60  RETURN
END

```

```

SUBROUTINE BESSJ(X1,B1,Y1) [4]

```

```

SUBROUTINE EFIELD(ALPHA,BETA,KA,KAY,PI,RATE,RCS,RPL,SILEN,SRLEN,
@ EVALUE)
C THIS SUBROUTINE COMPUTES E-FIELD MAGNITUDE AND PHASE FOR THE SIGNAL
C RECEIVED.
C DUE TO ONE MULTIPATH RAY REFLECTED FROM THE METAL TOWERS.
REAL KA,KAY
COMPLEX EVALUE
ARGONE = KA*SIN(ALPHA)
CALL BESSJ (ARGONE,1.0,B1)
G1 = 2*B1/(KA*SIN(ALPHA))
ARGTWO = KA*SIN(BETA)
CALL BESSJ (ARGTWO,1.0,B2)
G2 = 2*B2/(KA*SIN(BETA))
EMAG = ABS(G1*G2)*SQRT(RCS/(4*PI))/(SILEN*SRLEN)
C ACCOUNT FOR ATTENUATION BY RAIN
EXPO = -9.389E-9*RPL*RATE**1.31
EMAG = EMAG*10**EXPO
EPHASE = -KAY*(SILEN+SRLEN)+PI
EVALUE = CMLPX(EMAG*COS(EPHASE),EMAG*SIN(EPHASE))
RETURN
END

```

```

SUBROUTINE FIELD2(ALPHA,KA,KAY,PL,RATE,RCMAG,RCPHA,RD,RR,
@ EMULTI)
C THIS SUBROUTINE COMPUTES E-FIELD MAGNITUDE AND PHASE FOR THE SIGNAL
C RECEIVED DUE TO ONE MULTIPATH RAY REFLECTED FROM THE CONCRETE SURFACE.
COMPLEX EMULTI
REAL KA,KAY
ARGONE = KA*SIN(ALPHA)
CALL BESSJ(ARGONE,1.0,B1)
G1 = 2*B1/(KA*SIN(ALPHA))
EMAG = G1*G1*RCMAG/RD
C ACCOUNT FOR ATTENUATION BY RAIN (FROM BATTAN)
EXPO = -9.389E-9*PL*RATE**1.31
EMAG = EMAG*10**EXPO
EPHASE = RCPHA-KAY*RR
EMULTI = CMLPX(EMAG*COS(EPHASE),EMAG*SIN(EPHASE))
RETURN
END

```

SUBROUTINE GAMMA(X, GAM) [4]

SUBROUTINE PLYEVL(A, ND, X, ANS) [4]

SUBROUTINE RCHORZ (ALPHA, D, EPS2, EPS3, KAY, PI, GAMA)

C THIS SUBROUTINE CALCULATES A REFLECTION COEFFICIENT FOR A HORIZONTALLY
C POLARIZED SIGNAL INCIDENT ON A FLAT SURFACE COMPOSED OF TWO LAYERS OF
C DIFFERENT DIELECTRICS, WATER AND CONCRETE. THE DEPTH OF THE WATER IS D.
C IT IS ASSUMED THAT THE RADAR SIGNAL TRAVELS THROUGH AIR (FREE SPACE)
C BEFORE STRIKING THE FIRST SURFACE.

COMPLEX ARG1, ARG2, EPS2, EPS3, E2, E2PR, GAMA, GHTOP, GHBOT, J, PART,
@ RAD2, RAD3, C2, C3, THETA2, THETA3
REAL KAY
J = (0, 1)
ANGINC = PI/2 - ALPHA
RAD2 = SQRT(EPS2)
RAD3 = SQRT(EPS3)
PART = SIN(ANGINC)/RAD2
THETA2 = -J*LOG(J*PART+SQRT(1-PART*PART))
PART = SIN(THETA2)*RAD2/RAD3
THETA3 = -J*LOG(J*PART+SQRT(1-PART*PART))
C2 = COS(THETA2)
C3 = COS(THETA3)
ARG1 = -J*KAY*D*(RAD3*C3-RAD2*C2)
E2 = 0.5*(RAD3*C3/(RAD2*C2)+1)*CEXP(ARG1)
ARG2 = -J*KAY*D*(RAD3*C3+RAD2*C2)
E2PR = 0.5*(1-RAD3*C3/(RAD2*C2))*CEXP(ARG2)
GHTOP = COS(ANGINC)*(E2+E2PR)-RAD2*C2*(E2-E2PR)
GHBOT = COS(ANGINC)*(E2+E2PR)+RAD2*C2*(E2-E2PR)
GAMA = GHTOP/GHBT
RETURN
END

SUBROUTINE RCVERT (ALPHA, D, EPS2, EPS3, KAY, PI, GAMA)

C THIS SUBROUTINE CALCULATES A REFLECTION COEFFICIENT FOR A VERTICALLY
C POLARIZED SIGNAL INCIDENT ON A FLAT SURFACE COMPOSED OF TWO LAYERS OF
C DIFFERENT DIELECTRICS, WATER AND CONCRETE. THE DEPTH OF THE WATER IS D.
C IT IS ASSUMED THAT THE RADAR SIGNAL TRAVELS THROUGH AIR (FREE SPACE)
C BEFORE STRIKING THE FIRST SURFACE.

COMPLEX ARG1, ARG2, EPS2, EPS3, E2, E2PR, GAMA, GVTOP, GVBOT, J, PART,
@ RAD2, RAD3, C2, C3, THETA2, THETA3
REAL KAY
J = (0, 1)
ANGINC = PI/2 - ALPHA
RAD2 = SQRT(EPS2)
RAD3 = SQRT(EPS3)
PART = SIN(ANGINC)/RAD2
THETA2 = -J*LOG(J*PART+SQRT(1-PART*PART))
PART = SIN(THETA2)*RAD2/RAD3
THETA3 = -J*LOG(J*PART+SQRT(1-PART*PART))
C2 = COS(THETA2)
C3 = COS(THETA3)

```

ARG1 = -J*KAY*D*(RAD3*C3-RAD2*C2)
E2 = 0.5*(RAD3/RAD2 + C3/C2)*CEXP(ARG1)
ARG2 = -J*KAY*D*(RAD3*C3 + RAD2*C2)
E2PR = 0.5*(RAD3/RAD2 - C3/C2)*CEXP(ARG2)
GVTOP = COS(ANGINC)*RAD2*(E2+E2PR) - C2*(E2-E2PR)
GVBOT = COS(ANGINC)*RAD2*(E2+E2PR) + C2*(E2-E2PR)
GAMA = GVTOP/GVBOT
RETURN
END

```

```

SUBROUTINE REFRAC(F, T, DIELC)
C THIS SUBROUTINE COMPUTES THE REAL ( XN ) AND NEGATIVE IMAGINARY
C ( XK ) PARTS OF THE INDEX OF REFRACTION OF PURE WATER AT THE
C FREQUENCY F (IN HERTZ) AND TEMPERATURE T (IN DEGREES CELSIUS).
C THE SUBROUTINE ALSO FINDS THE DIELECTRIC CONSTANT (PERMITTIVITY)
C OF WATER.
C
C THE VARIABLES F, T, XN, AND XK MUST BE REAL*8 IN THE CALLING PROGRAM
C FOR CONSISTENCY, EVEN THOUGH XN AND XK ARE NOT THAT ACCURATE.
C

```

```

REAL*8 F, T, XN, XK
COMPLEX*8 DIELC, EPSDEN, SQDL
EPSZRO=88.045 - .4147*T + 6.295E-4*T**2 + 1.075E-5*T**3
TWPITAU=1.1109E-10-3.824E-12*T+6.938E-14*T**2 - 5.096E-16*T**3
XEPSDN=-TWPITAU*F
EPSDEN=CMPLX(1., XEPSDN)
DIELC=4.9 + (EPSZRO-4.9)/EPSDEN
SQDL=CSQRT(DIELC)
XN=REAL(SQDL)
XK=-AIMAG(SQDL)
RETURN
END

```

C***** BEGINNING OF MAIN PROGRAM *****

```

REAL KA, KAY, LAMBDA, LENGTH
REAL*8 CARRIER, TEMP, XN, XK
INTEGER FLAG, HFLAG, POLAR
COMPLEX DIELC, EDIREC, EMULTI, EPREV, EPS2, EPS3, EVALUE, ETOTAL, GAMA,
@ TERM

C ENTER FIGURES WHICH DETERMINE POSITIONS OF THE TRANSMITTER AND RECEIVER
C AND INCREMENTS AT WHICH THE COMPUTATIONS WILL BE MADE.
WRITE(*,*) 'UNITS ARE INCHES, RADIANS, OR HERTZ.'
WRITE(*,*) 'ENTER TRANSMITTER HEIGHT ABOVE GROUND.'
READ(*,*) ZR
WRITE(*,*) 'ENTER HORIZONTAL DISTANCE FROM STARTING POINT TO THE
@FIRST TOWER.'
READ(*,*) STA1
WRITE(*,*) 'ENTER HORIZONTAL DISTANCE FROM THE LAST TOWER TO THE
@RECEIVER.'
READ(*,*) DIST
B = STA1 + 6432.6 + DIST

```

```

E = 429.148
F = -13.816
WRITE(*,*) 'ENTER INCREMENTS OF TRANSMITTER HORIZONTAL POSITION.'
READ(*,*) XINC
WRITE(*,*) 'ENTER INCREMENTS OF TOWER HEIGHT.'
READ(*,*) HINT
WRITE(*,*) 'ENTER ANTENNA DIAMETER.'
READ(*,*) DIAMTR
RADANT = 0.5*DIAMTR
WRITE(*,*) 'USING RADIAN MEASURE, ENTER BEAMWIDTH WITHIN WHICH YOU
@ WISH TO CONSIDER MULTIPATH SIGNALS. NARROWING THE BEAMWIDT
@H WILL SPEED THE RUNNING OF THE PROGRAM.'
READ(*,*) BEAM
SPAN = 0.5*BEAM
WRITE(*,*) 'ENTER CARRIER FREQUENCY IN HERTZ.'
READ(*,*)CARRIER
LAMBDA = 2.998E10/CARRIER/2.54
PI = 3.1415926535
KAY = 2*PI/LAMBDA
RADCYL = 7.0751
KA = KAY*RADANT
WRITE(*,*) 'ENTER "1" FOR HORIZONTAL POLARIZATION OR "2" FOR VERTI
@CAL POLARIZATION.'
READ(*,*) POLAR
WRITE(*,*) 'ENTER RAIN RATE IN INCHES PER HOUR.'
READ(*,*) RATE
RATE = RATE*25.4
WRITE(*,*) 'ENTER RAIN (AMBIENT) TEMPERATURE IN DEGREES CELCIUS.'
READ(*,*) TEMP
CALL REFRAC (CARRIER, TEMP, DIELC)
EPS2 = CONJG(DIELC)
EPS3 = (4.65, -.072)

OPEN (1, FILE = 'CONES1.DAT', STATUS = 'NEW')
OPEN (2, FILE = 'CONES2.DAT', STATUS = 'NEW')
OPEN (3, FILE = 'CONES3.DAT', STATUS = 'NEW')

```

C***** REFLECTIONS FROM VERTICAL TOWER SECTIONS *****

```

200 XR = 0
C RESET ETOTAL, A
300 ETOTAL =(0,0)
A = STA1

```

C LOOK ONLY AT VERTICAL SUPPORTS WHICH ARE IN FRONT OF THE RADAR AND ARE
C ILLUMINATED BY THE RADAR.

```

DO 350 I = 1,5
  IF (A.LE.XR) THEN
    A = A + 1286.52
  ELSE
    GOTO 400
  ENDIF
350 CONTINUE

```

```

400 CALL BARILV(A, SPAN, XR, ZR, LENGTH, FLAG)
    IF (FLAG.EQ.1) GOTO 510

C RESET H,HFLAG. CALCULATE WHETHER OR NOT RAYS DRAWN FROM THE VERTICAL
SUPPORTS
C TO THE ANTENNAS WOULD BE WITHIN THE SPECIFIED BEAMWIDTHS.
410 H = -13.816
    HFLAG = 0
450 YT = (449.034 - H) * 0.3345953 + 274.281
    D = SQRT(YT*YT + (ZR-H)*(ZR-H))
    ALPHA = ATAN (D/(A-XR))
    IF (ALPHA .GT. SPAN) GOTO 500
    BETA = ATAN (D/(B-A))
    IF (BETA .GT. SPAN) GOTO 500

C CALCULATE WHETHER OR NOT A RAY FROM THE VERTICAL SUPPORT TO THE RECEIVING
C ANTENNA WOULD BE WITHIN THE CONE OF ENERGY REFLECTED FROM THE CYLINDRICAL
C SURFACE OF THE VERTICAL SUPPORT. HFLAG = 0 MEANS THAT NO SPECULAR POINTS
C OF INTEREST HAVE YET BEEN FOUND ON A GIVEN TOWER FOR A GIVEN XR POSITION.
    U = YT-E
    V = H-F
    W = H-ZR
    TOP1 = U*YT + V*W
    BOT1 = SQRT( (U**2 + V**2) * ((A-XR)**2 + YT**2 + W**2) )
    THETA1 = ACOS(TOP1/BOT1)
    TOP2 = -TOP1
    BOT2 = SQRT( (U**2 + V**2) * ((B-A)**2 + YT**2 + W**2) )
    THETA2 = ACOS(TOP2/BOT2)
    THICK = LAMBDA/LENGTH
    IF (ABS(THETA2-THETA1).GT.THICK) GOTO 500
    IF (HFLAG.EQ.0) THEN
        HMIN = H
        HFLAG = 1
    ENDIF

C INCREASE H (HEIGHT ON A GIVEN TOWER).
500 IF ((H+HINT).LE.449.034) THEN
    H = H+HINT
    GOTO 450
ENDIF
IF (HFLAG.EQ.0) GOTO 510
HMAX = H

C CALCULATE PARAMETERS FOR A TOWER HEIGHT MIDWAY IN THE RANGE OF INTEREST.
H = (HMIN + HMAX)/2
YT = (449.034 - H) * 0.3345953 + 274.281
D = SQRT(YT*YT + (ZR-H)*(ZR-H))
ALPHA = ATAN (D/(A-XR))
BETA = ATAN (D/(B-A))
U = YT-E
V = H-F
W = H-ZR
TOP1 = U*YT + V*W

```

```

BOT1 = SQRT((U**2 + V**2)*((A-XR)**2 + YT**2 + W**2))
THETA1 = ACOS(TOP1/BOT1)

```

```

C DETERMINE THE SPECULAR POINT FROM AROUND THE CIRCUMFERENCE OF THE
C CYLINDER AT THE HEIGHT JUST CALCULATED. THEN GET THE RADAR CROSS SECTION
C FOR THE REFLECTOR.

```

```

CALL ANGLES(A, B, H, THETA1, XR, YT, ZR, ANGINC, PHI, SIHATX, SIHATY, SIHATZ,
@ SILEN, SRLLEN, ZBHATX, ZBHATY, ZBHATZ)
RCS = 4*KAY*RADCYL*LENGTH**2*COS(ANGINC)*COS(PHI/2)-----

```

```

C CALCULATE PATH LENGTH FOR MULTIPATH SIGNAL THROUGH THE RAINFALL AREA.

```

```

IF (XR.LT.STA1) THEN
  YENTER = YT - (A-STA1)*YT/(A-XR)
  ZENTER = H - (A-STA1)*(H-ZR)/(A-XR)
  RPL1 = SQRT((A-STA1)**2 + (YT-YENTER)**2 + (H-ZENTER)**2)
ELSE RPL1 = SILEN
ENDIF
YLEAVE = (B-STA1-6432.6)*YT/(B-A)
ZLEAVE = ZR - (B-STA1-6432.6)*(ZR-H)/(B-A)
RPL2 = SQRT((STA1+6432.6-A)**2 + (YLEAVE-YT)**2 + (ZLEAVE-H)**2)
RPL = RPL1 + RPL2

```

```

C CALCULATE INTENSITY OF ENERGY REFLECTED TO THE RECEIVING ANTENNA FROM
C VERTICAL TOWER PORTIONS ON ONE SIDE OF TRACK.

```

```

CALL EFIELD(ALPHA, BETA, KA, KAY, PI, RATE, RCS, RPL, SILEN, SRLLEN, EVALUE)
ETOTAL = ETOTAL + EVALUE

```

```

C INCREASE A (GO TO NEXT TOWER).

```

```

510 IF (A+1286.52 .LE. STA1+6432.6) THEN
  A = A + 1286.52
  GOTO 400
ENDIF

```

```

C ADD SIGNALS FROM BOTH SIDES OF THE TRACK TO FIND TOTAL EFIELD MAGNITUDE
C AND PHASE. STORE RESULTS IN UNIT 1.

```

```

ETOTAL = 2*ETOTAL
WRITE(1, *) ETOTAL

```

```

C INCREASE XR (MOVE RADAR TO NEXT HORIZONTAL POSITION).

```

```

IF (XR+XINC .LE. STA1+6432.6) THEN
  XR = XR + XINC
  GOTO 300
ENDIF
CLOSE(1)

```

```

C***** REFLECTIONS FROM HORIZONTAL TOWER SECTIONS *****

```

```

OPEN(1, FILE = 'CONES1.DAT', STATUS = 'OLD')
XR = 0

```

```

C RESET ETOTAL, A

```

```

520 ETOTAL =(0,0)
A = STA1

```

```

C LOOK ONLY AT HORIZONTAL TOWER SECTIONS WHICH ARE IN FRONT OF THE RADAR
C AND ARE ILLUMINATED BY THE RADAR.
  DO 530 I = 1,5
    IF (A.LE.XR) THEN
      A = A + 1286.52
    ELSE
      GOTO 540
    ENDIF
530 CONTINUE
540 CALL BARILH(A, SPAN, XR, ZR, LENGTH, FLAG)
    IF(FLAG.EQ.1) GOTO 550

C CALCULATE WHETHER OR NOT A RAY FROM THE HORIZONTAL BAR TO THE ANTENNAS
C WOULD
C BE WITHIN THE SPECIFIED BEAMWIDTHS.
  D = 449.034-ZR
  ALPHA = ATAN (D/(A-XR))
  IF (ALPHA .GT. SPAN) GOTO 550
  BETA = ATAN (D/(B-A))
  IF (BETA .GT. SPAN) GOTO 550

C CALCULATE WHETHER OR NOT A RAY FROM THE HORIZONTAL BAR TO THE RECEIVING
C ANTENNA WOULD BE WITHIN THE CONE OF ENERGY REFLECTED FROM THE CYLINDRICAL
C SURFACE OF THE HORIZONTAL BAR.
  THETA1 = PI/2 - ALPHA
  THETA2 = PI/2 - BETA
  THICK = LAMBDA/LENGTH
  IF (ABS(THETA2-THETA1).GT.THICK) GOTO 550

C FIND RADAR CROSS SECTION OF THE REFLECTOR.
  SILEN = SQRT((A-XR)**2 + D**2)
  SRLLEN = SQRT((B-A)**2 + D**2)
  RCS = 4*KAY*RADCYL*LENGTH**2*COS(THETA1)*COS((THETA1+THETA2)/2)

C CALCULATE PATH LENGTHS THROUGH THE SIMULATED RAIN.
  IF (XR.LT.STA1) THEN
    RPL1 = SQRT((A-STA1)**2 + (449.034-ZR-STA1*TAN(ALPHA))**2)
  ELSE
    RPL1 = SQRT((A-XR)**2 + (449.034-ZR)**2)
  ENDIF
  SIDE = (B-STA1-6432.6)*TAN(BETA)
  RPL2 = SQRT((A-STA1-6432.6)**2 + (449.034-ZR-SIDE)**2)
  RPL = RPL1 + RPL2

C CALCULATE INTENSITY OF ENERGY REFLECTED TO THE RECEIVING ANTENNA FROM
C HORIZONTAL TOWER PORTIONS.
  CALL EFIELD(ALPHA, BETA, KA, KAY, PI, RATE, RCS, RPL, SILEN, SRLLEN, EVALUE)
  ETOTAL = ETOTAL + EVALUE

C INCREASE A (GO TO NEXT TOWER).
550 IF (A+1286.52 .LE. STA1+6432.6) THEN
  A = A + 1286.52
  GOTO 540

```

```

ENDIF

C ADD MULTIPATH SIGNALS TO EFIELD VALUES STORED IN UNIT 1.
  READ(1,*) EPREV
  ETOTAL = EPREV+ETOTAL
  WRITE(2,*) ETOTAL

C INCREASE XR (MOVE RADAR TO NEXT HORIZONTAL POSITION).
  IF (XR+XINC .LE. STA1+6432.6) THEN
    XR = XR + XINC
    GOTO 520
  ENDIF
  CLOSE(2)

C***** REFLECTIONS FROM CONCRETE SURFACE *****

  OPEN(2, FILE = 'CONES2.DAT', STATUS = 'OLD')
  KOUNT = 0
  XR = 0
560 RD = B-XR
  RR = SQRT(4*ZR**2 + RD**2)
  ALPHA = ATAN(ZR*2/RD)
  IF (ALPHA.GT.SPAN) THEN
    EMULTI = (0.0,0.0)
    GO TO 579
  ENDIF
  COSALF = COS(ALPHA)
  SINALF = SIN(ALPHA)

C CALCULATE DISTANCE TRAVELLED BY MULTIPATH SIGNAL THROUGH THE SIMULATED
C RAIN
  SPEC = (XR+B)/2
  PL1 = SQRT((RD/2)**2 + ZR**2)
  RPL1 = PL1*(SPEC-STA1)/(SPEC-XR)
  IF (SPEC.LT.STA1) RPL1 = 0
  IF ((XR.LT.STA1).AND.(SPEC.GT.STA1+6432.6)) THEN
    DPL1 = PL1*(SPEC-STA1-6432.6)/(SPEC-XR)
    COMBPL = PL1*(SPEC-STA1)/(SPEC-XR)
    RPL1 = COMBPL - DPL1
  ENDIF
  IF((STA1.LE.XR).AND.(XR.LE.STA1+6432.6).AND.(SPEC.LE.STA1+6432.6))
@ RPL1 = PL1
  IF((STA1.LE.XR).AND.(XR.LE.STA1+6432.6).AND.(SPEC.GT.STA1+6432.6))
@ THEN
    DPL1 = PL1*(SPEC-STA1-6432.6)/(SPEC-XR)
    RPL1 = PL1-DPL1
  ENDIF
  IF ((XR.GT.STA1+6432.6).AND.(SPEC.GT.STA1+6432.6)) RPL1 = 0

  PL2 = PL1
  RPL2 = PL2*(B-SPEC-DIST)/(B-SPEC)
  IF (SPEC.LT.STA1) THEN
    DPL2 = PL2*(STA1-SPEC)/(B-SPEC)

```



```

        COMBPL = PL2*(STA1-SPEC+6432.6)/(B-SPEC)
        RPL2 = COMBPL-DPL2
    ENDIF
    IF (SPEC.GT.STA1+6432.6) RPL2 = 0
    PL = RPL1+RPL2

C CALCULATE REFLECTION COEFFICIENTS FOR TRACK SURFACE. IF THERE IS NO RAIN,
C ASSUME TRACK IS DRY AND USE THE SIMPLIFIED FORMULATION BELOW REQUIRING
C ONLY EPS3, PERMITTIVITY OF CONCRETE. IN RAINY CONDITIONS, CALL THE
C SUBROUTINES RCHORZ AND RCVERT REQUIRING EPS2, PERMITTIVITY OF WATER, AND
C EPS3.
    IF (RATE .EQ. 0) THEN
        TERM = SQRT(EPS3 - COSALF**2)
        IF (POLAR.EQ.1) THEN
            GAMA = (SINALF-TERM)/(SINALF+TERM)
        ELSE
            GAMA = (EPS3*SINALF-TERM)/(EPS3*SINALF+TERM)
        ENDIF
        GO TO 570
    ENDIF

C CALCULATE WATER DEPTH ON TRACK. ALLOW 20 FT AT EITHER END OF TOWERS FOR
WATER
C LAYER ON CONCRETE TO TAPER OFF TO NOTHING.
    IF ((SPEC.LT.STA1-240).OR.(SPEC.GT.STA1+6672.6)) DEPTH = 0
    IF ((SPEC.GE.STA1-240).AND.(SPEC.LE.STA1))
        @ DEPTH = .059*(SPEC-STA1+240)/240
    IF ((SPEC.GT.STA1).AND.(SPEC.LT.STA1+6432.6)) DEPTH = .059
    IF ((SPEC.GE.STA1+6432.6).AND.(SPEC.LE.STA1+6672.6))
        @ DEPTH = 0.059*(STA1+6672.2-SPEC)/240

    IF (POLAR.EQ.1) THEN
        CALL RCHORZ (ALPHA, DEPTH, EPS2, EPS3, KAY, PI, GAMA)
    ELSE
        CALL RCVERT (ALPHA, DEPTH, EPS2, EPS3, KAY, PI, GAMA)
    ENDIF

C GET MAGNITUDE AND PHASE OF REFLECTION COEFFICIENT
570 RCMAG = SQRT(REAL(GAMA)**2 + AIMAG(GAMA)**2)
    RCPHA = ATAN2(AIMAG(GAMA), REAL(GAMA))

C CALCULATE E-FIELD STRENGTH OF MULTIPATH SIGNAL
    CALL FIELD2(ALPHA, KA, KAY, PL, RATE, RCMAG, RCPHA, RD, RR, EMULTI)

C ***** SUM DIRECT-PATH AND MULTIPATH SIGNALS *****

C CALCULATE DISTANCE TRAVELLED BY DIRECT-PATH SIGNAL THROUGH THE RAIN
    IF (XR.LT.STA1) DIRPL = 6432.6
    IF ((XR.GE.STA1).AND.(XR.LE.STA1+6432.6)) DIRPL = STA1+6432.6-XR
    IF (XR.GT.STA1+6432.6) DIRPL = 0

C CALCULATE E-FIELD STRENGTH OF DIRECT-PATH SIGNAL, ACCOUNTING FOR
C ATTENUATION BY RAIN.

```

```

579 SMAG = 1/RD
    EXPO = -9.389E-9*DIRPL*RATE**1.31
    SMAG = SMAG*10**EXPO
    SPHASE = -KAY*RD
    EDIREC = CMPLX(SMAG*COS(SPHASE), SMAG*SIN(SPHASE))

C STORE POWER OF DIRECT-PATH SIGNALS AND TOTAL RECEIVED SIGNALS FOR
C COMPARISON
    IF (XR.LE.STA1+6432.6) THEN
        READ(2,*) EPREV
        ETOTAL = EPREV + EMULTI + EDIREC
    ELSE
        ETOTAL = EMULTI + EDIREC
    ENDIF
    PDIREC = AIMAG(EDIREC)**2 + REAL(EDIREC)**2
    PTOTAL = AIMAG(ETOTAL)**2 + REAL(ETOTAL)**2
    WRITE(3,580) XR, PDIREC, PTOTAL
580 FORMAT('XR, PDIREC, PTOTAL = ', F10.2, 2X, 1P, E12.6, 2X, E12.6)
    KOUNT = KOUNT + 1
590 IF (XR+XINC.LE.B) THEN
    XR = XR+XINC
    GOTO 560
ENDIF
WRITE(3,*) 'KOUNT = ', KOUNT

CLOSE(1)
CLOSE(2)
CLOSE(3)
STOP
END

```



Report Documentation Page

1. Report No. NASA TM-101657		2. Government Accession No.		3. Recipient's Catalog No.	
4. Title and Subtitle Radar Multipath Study for Rain-On-Radome Experiments at the Aircraft Landing Dynamics Facility				5. Report Date May 1990	
				6. Performing Organization Code	
7. Author(s) Anne I. Mackenzie Leo D. Staton				8. Performing Organization Report No.	
				10. Work Unit No. 505-66-11-07	
9. Performing Organization Name and Address NASA Langley Research Center Hampton, VA 23665-5225				11. Contract or Grant No.	
				13. Type of Report and Period Covered Technical Memorandum	
12. Sponsoring Agency Name and Address National Aeronautics and Space Administration Washington, DC 20546-0001				14. Sponsoring Agency Code	
				15. Supplementary Notes	
16. Abstract This technical memorandum describes an analytical study to determine the feasibility of a rain-on-radome experiment at the Aircraft Landing Dynamics Facility (ALDF) at the Langley Research Center. The experiment would measure the effects of heavy rain on the transmission of X-band weather radar signals, looking in particular for sources of anomalous attenuation. Feasibility is determined with regard to multipath signals arising from the major structural components of the ALDF. A computer program simulates the transmit and receive antennas, direct-path and multipath signals, and expected attenuation by rain. In the simulation, antenna height, signal polarization, and rainfall rate are variable parameters. The study shows that the rain-on-radome experiment is feasible with regard to multipath signals. The total received signal, taking into account multipath effects, could be measured by commercially available equipment. The study also shows that horizontally polarized signals would produce better experimental results than vertically polarized signals.					
17. Key Words (Suggested by Author(s)) weather radar, multipath, circular aperture, specular reflection, complex permittivity, reflection coefficient			18. Distribution Statement  Subject Category 32		
19. Security Classif. (of this report) unclassified		20. Security Classif. (of this page) unclassified		21. No. of pages 41	22. Price

