

NASA  
Technical Memorandum 105629

91283  
P-23 AVSCOM  
Technical Report 91-C-023

# Cyclopentadiene Evolution During Pyrolysis-Gas Chromatography of PMR Polyimides

William B. Alston  
*Propulsion Directorate*  
*U.S. Army Aviation Systems Command*  
*Lewis Research Center*  
*Cleveland, Ohio*

Richard E. Gluyas  
*Lewis Research Center*  
*Cleveland, Ohio*

and

William J. Snyder  
*Bucknell University*  
*Lewisburg, Pennsylvania*

Prepared for the  
Fourth International Conference on Polyimides  
sponsored by the Society of Plastic Engineers  
Ellenville, New York, October 30–November 1, 1991

**NASA**



(NASA-TM-105629) CYCLOPENTADIENE EVOLUTION  
DURING PYROLYSIS-GAS CHROMATOGRAPHY OF PMR  
POLYIMIDES (NASA) 23 p CSCL 11C

N92-25348

Unclas  
G3/27 0091283



# CYCLOPENTADIENE EVOLUTION DURING PYROLYSIS-GAS CHROMATOGRAPHY OF PMR POLYIMIDES

William B. Alston  
Propulsion Directorate  
U.S. Army Aviation Systems Command  
Lewis Research Center  
Cleveland, Ohio 44135

Richard E. Gluyas\*  
Materials Division  
National Aeronautics and Space Administration  
Lewis Research Center  
Cleveland, Ohio 44135

William J. Snyder\*\*  
Department of Chemical Engineering  
Bucknell University  
Lewisburg, Pennsylvania 17837

## ABSTRACT

The effects of formulated molecular weight (FMW), extent of cure, and cumulative aging on the amount of cyclopentadiene (CPD) evolved from Polymerization of Monomeric Reactants (PMR) polyimides were investigated by pyrolysis-gas chromatography (PY-GC). The PMR polyimides are addition crosslinked resins formed from an aromatic diamine, a diester of an aromatic tetracarboxylic acid and a monoester of 5-norbornene-2,3-dicarboxylic acid. The PY-GC results were related to the degree of crosslinking and to the thermo-oxidative stability (weight loss) of PMR polyimides. Thus, PY-GC was shown to be a valid technique for the characterization of PMR polyimide resins and composites via correlation of the CPD evolved versus the thermal history of the PMR sample.

## INTRODUCTION

The Polymerization of Monomeric Reactants (PMR) polyimides are high temperature resistant resins first reported by workers at the NASA Lewis Research Center [1,2]. Today, the resin, known as PMR-15, is mainly used as the matrix in fiber reinforced composites for a variety of advanced aerospace applications [3,4]. Currently, PMR-15 is an addition-type, thermally crosslinked resin, which is readily processed to yield fiber reinforced composites with excellent mechanical property retention for up to 2000 hr at 316 °C in air [5]. However, the effects of composition, processing conditions, and high temperature aging in air are not thoroughly understood in terms of chemical changes occurring in the resin during these processes. For example, it is known that the post-curing process (heating in air after curing) affects mechanical properties [5] but the associated chemical changes are not thoroughly understood. Unfortunately, chemical characterization of addition crosslinked PMR resins is difficult by standard analytical methods such as nuclear magnetic resonance (NMR), liquid chromatography and gel permeation chromatography because of the insolubility and intractability of these resins. Thus, a technique that does not require polymer solubility for analysis would be desirable.

Pyrolysis-gas chromatography (PY-GC) is one such technique and it has been used [6,7] to characterize insoluble polymers but it has not been used to make systematic quantitative measurements on the PMR polyimides. Thus, the purposes of this

---

\* Deceased.



\*\* To whom correspondence should be addressed.

investigation are: (1) to quantitatively measure and evaluate the significance of the evolution of cyclopentadiene (CPD) during pyrolysis of cured or postcured PMR resins; (2) to identify and obtain quantitative information required for the future development of useful life prediction methods for PMR resin/graphite fiber composites in thermo-oxidative environments; and (3) to demonstrate how the PY-GC technique can be used to characterize the cure, postcure and aging chemistry of PMR resins and PMR graphite fiber composites.

## EXPERIMENTAL

**STARTING MATERIALS**—The materials used in this study are the three monomers for preparing PMR polyimides: (1) monomethyl ester of cis-5-norbornene-endo-2,3-dicarboxylic acid (Nadic Ester abbreviated NE), mp 99-100.5 °C; (2) 4,4'-methylenedianiline (MDA), mp 91-93 °C; and (3) the dimethyl ester of 3,3',4,4'-benzophenonetetracarboxylic acid (BTDE). These were obtained from commercial sources except for the BTDE which was prepared from commercially obtained dianhydride (BTDA), mp 215-217 °C, by reacting BTDA with sufficient methanol to form a 50 weight percent solution of BTDE. Other commercially obtained materials used in this study were: (1) cis-5-norbornene-endo-2,3-dicarboxylic anhydride (Nadic Anhydride or NA), mp 164-166 °C; and (2) dicyclopentadiene used for the preparation of CPD, bp 40-42 °C, by thermal decomposition. Table I shows the structural formulas for these materials.

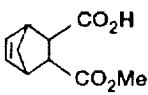
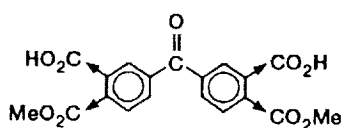
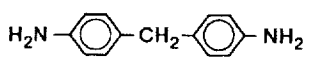
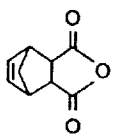
TABLE I.—STRUCTURES OF MATERIALS

Structure	Name	Abbreviation
	Monomethyl ester of cis-5-norbornene-endo-2,3-dicarboxylic acid (Nadic Ester)	NE
	Dimethyl ester of 3,3',4,4'-benzophenonetetracarboxylic acid	BTDE
	4,4'-Methylenedianiline	MDA
	cis-5-Norbornene-endo-2,3-dicarboxylic anhydride (Nadic Anhydride)	NA
	Cyclopentadiene	CPD

RESIN PREPARATION—Solutions containing 50 weight percent solids in anhydrous methanol were prepared using the monomers, NE, MDA, and BTDE. These solutions were prepared with formulated molecular weights (FMW) of 1000, 1250, 1500, 2000 (corresponding to PMR-10, PMR-12.5, PMR-15 and PMR-20). The expression used to calculate FMW is:

$$\text{FMW} = n \text{MW}_{\text{BTDE}} + (n+1)\text{MW}_{\text{MDA}} + 2\text{MW}_{\text{NE}} - 2(n+1)(\text{MW}_{\text{water}} + \text{MW}_{\text{methanol}})$$

where  $\text{MW}_{\text{BTDE}}$ , etc., are the molecular weights of the compounds indicated in the subscripts [2]. Thus, the molar ratios of BTDA:MDA:NE equal  $n:(n+1):2$ . Also, a solution having a molar ratio of 2:1 for NE:MDA without BTDE was prepared as a model compound. These solutions were air-dried at 75 °C for 24 hr and the residues were imidized (staged) by heating for 1 hr at 204 °C. The staged imides were ground into powders and a portion of each specimen of powder was used to prepare cured resins. The procedure to prepare cured resin was to weigh about 15 g of the PMR molding powder into a 5.08-cm diam cylindrical hardened-steel mold which was closed by slip-fit brass pistons. The inside of the mold and the piston surfaces were previously coated with a thin film of Frekote-33 mold release compound. Cured resin was prepared for each of the above five compositions by heating under 13.8 MPa (2000 psi) pressure in the mold for 1 hr at 316 °C. The average heatup rate to 316 °C was about 5 °C/min. In all cases, a small contact pressure was applied to barely close the press at the beginning of heatup. The temperatures at which the full 13.8 MPa pressure was applied were:  $300 \pm 5$  °C for 2NE/MDA and PMR-10,  $275 \pm 5$  °C for PMR-12.5,  $250 \pm 5$  °C for PMR-15 and  $230 \pm 5$  °C for PMR-20. Different temperatures were used because the lower the FMW composition, the greater the resin flow during curing, hence the resin must be advanced further using a higher cure temperature before final pressure could be applied. Cured resin was prepared for the PMR-15 composition at 316 °C for cure times (dwell times) of 1, 2, and 7 hr. Also cured resin specimens were prepared for the PMR-15 composition using a 1 hr cure time and varying the cure temperatures (274, 288, 302, 316, 343, and 371 °C).

A portion of each of these dense cylindrical (5.08-cm diam by 0.635-cm thick) pieces of resin obtained on curing was reduced to powder by preparing turnings on a lathe, grinding in a pellet mill, and sieving to obtain a 74 to 149  $\mu\text{m}$  particle size (-100/200 powder fraction from U.S. standard sieve). Samples of the PMR-15 resin powder cured at 316 °C for 1 hr were aged in air at 316 °C for 1/3, 1, 3, 6, 12, 24, and 96 hr. PMR-15 resin powder samples were also aged in air for 1 hr at temperatures of 274, 288, 302, 316, 343, and 371 °C.

CROSSLINK PREPARATION—A derivative of the crosslinking material from cured (1 hr/316 °C) 2NE/MDA was prepared by digesting the resin in hydrazine monohydrate (85 percent solution w/w) at about 75 °C for an extended period of time, namely 150 hr (method adapted from [8,9]), to form MDA and the N-aminoimide of nadic crosslink [10]. The mixture then was acidified with 6N-HCl solution, adjusted to pH 10 with NaOH, stirred for 12 hr at about 90 °C, and extracted four times with chloroform. The chloroform containing the extracted material was dried, filtered, the chloroform removed by evaporation, and the residue (MDA) weighed. The recovery of MDA from the resin specimen was 98 percent of theoretical. The aqueous layer was acidified with HCl to a

pH of 4. This solution (about 500 ml in volume) was filtered through a Millipore molecular filter (with a nominal molecular weight limit of  $10^3$ ), to a residual of 25 ml. Then, 400 ml of acidified water was added to the residual 25 ml and the solution volume again reduced to 25 ml by filtering. This latter step was repeated and, finally, the residual of 25 ml was dried in air at 50 °C. The resulting tan-colored solid was 36 percent of theoretical yield assuming the solid to be a mixture of the N-aminoamide acid and the N-aminoimide of the crosslink. The remainder of the nadic crosslink presumably was lost through the filter as a low molecular weight fraction.

In another approach, a model polymer was prepared by polymerizing NA (cis-5-norbornene-endo-2,3-dicarboxylic anhydride) with a method analogous to that used for curing 2NE/MDA. The NA was placed in a 5.08-cm diam cylindrical mold closed with slip-fit brass pistons and slowly heated to 316 °C. Between approximately 316 to 350 °C, pressure was gradually increased to 13.8 MPa. An amber-colored, brittle polymer was obtained and is believed to have been formed by thermally initiated crosslinking of the NA. This material was prepared to serve as a possible model structure for the crosslink formed in the PMR system.

**APPARATUS AND PROCEDURES**—The chromatograms of the pyrolysis were obtained by using a Chemical Data Systems pyroprobe (CDS-pyroprobe) on two different GC systems, (a Chemical Data CDS-820 and a Perkin Elmer 810), each consisting of a pyrolysis type injection port, temperature programmable column, flame ionization detector, and electronic integrator. The major differences between the two sets of apparatus were the use of a delay coil and a 0.3175-cm diam by 2.43-m 10 percent SE-30 on Chromosorb WAW stainless steel column on the CDS-820 versus direct injection on a 0.3175-cm diam by 6.09-m column on the PE 810 system. The second type of column showed the better resolution but the chromatograms obtained on the two types of columns were in good agreement, particularly in the quantitative measurements of the CPD peak areas obtained from pyrolysis of NA. Solid samples of 100 to 500  $\mu\text{g}$  were weighed into 0.318-cm diam by 2.54-cm quartz tubes and pyrolyzed by heating a platinum heater/resistance thermometer to 800 °C for a fixed time (usually 10 sec). The carrier gas for these studies was helium at 40 ml/min. The columns typically were programmed from 40 to 202 °C at 5 to 6 °C/min and held at the upper temperature for 15 min. The pyrolyzer probe interface was maintained at 150 °C and the GC detector temperature was 250 °C. In addition, the CDS pyroprobe was coupled to a Finnegan 4021 GC-quadruples mass spectrometer to confirm the identity of the CPD peak.

The glass transition temperatures ( $T_g$ ) of PMR-15 specimens were obtained by thermomechanical analysis (on a DuPont 943 TMA) using a penetration probe loaded with 5 g and linearly programmed from ambient to 450 °C at 20 °C/min. The temperature of inflection was taken as a measure of the  $T_g$  and correlated with the extent of cure determined by pyrolysis GC.

## RESULTS AND DISCUSSION

**PMR CROSSLINKER CHEMISTRY**—The monomer mixtures used in this study form norbornenyl (nadicyl) endcapped imides after removal of solvent and heating at

204 °C for 1 hr. This reaction results in an imide oligomer structure of I [2] where  $n$  determines the FMW.

Subsequently, upon curing under pressure, typically at 316 °C for 1 hr, the norbornenyl endgroups, (a maleimide reacted with a CPD), undergo a thermally initiated reverse Diels-Alder reaction resulting in a crosslinked material. The crosslinking reaction has been investigated on model compounds [11-14] and it has been historically hypothesized that this reaction results in structures of the following types (II, III, and IV):

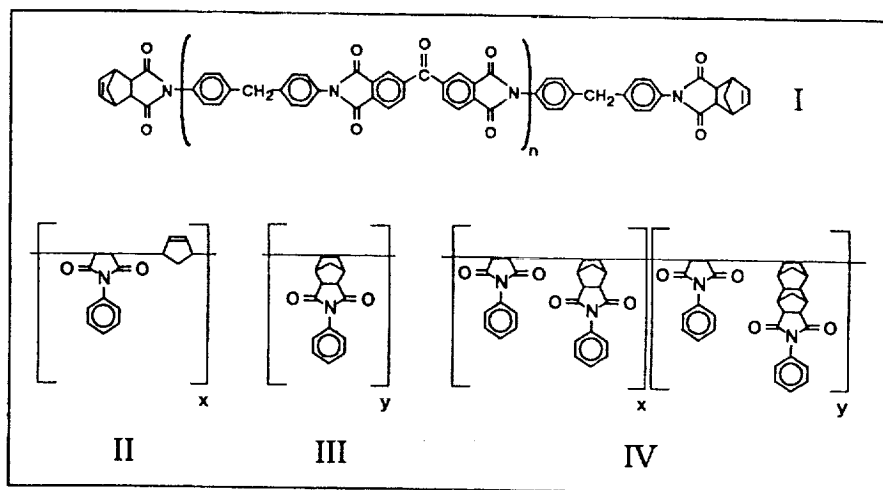

Structure II results from an initial reverse Diels-Alder reaction step followed by a hetero-nuclear addition reaction while structure III results from homo-nuclear addition polymerization. The relative number of cyclopentyl and succinimide (maleimide without the double bond) groups in structure II would depend on the amount of CPD available during the polymerization reaction. Because closed, tight-fitting molds were used to cure the resins, insignificant loss of CPD occurred. Therefore, the relative numbers of these groups in the crosslink chain are expected to be equal. However, the absence of olefin resonances in the proton NMR spectra [10], and the negative results of bromination experiments for olefins in these materials [12], suggest a very low incidence of cyclopentyl type groups (olefins). Hence, structures of type II are unlikely to occur. Structures of type III are also considered to be unlikely because of kinetic and spatial requirements [4,15]. Instead, if one looks at the polymerization as an alternating copolymerization of a maleimide group and the olefin on the nadimide endgroup or an olefin on the higher bicyclic structure, then the lack of observed olefin characteristics [10,12] would be consistent with the resulting polymerization structure IV. Such a polymerization mechanism has been demonstrated in model compounds studies [16-18] and also the polymerization has been shown to be dependent on the concentration of maleimide endgroups formed by the reverse Diels-Alder reaction [19].

**CPD EVOLUTION**—The amount of CPD available through pyrolysis of staged, cured, postcured and aged resins depends on: (1) the initial concentration of norbornenyl endgroups, (2) the cure temperature and time, (3) the postcure temperature and time, and (4) the aging temperature and time. Although aging may be considered an extension of the postcure process, for the purpose of this paper postcure will be defined as the

process that occurs during the initial aging, typically during the first 16 hr, when the  $T_g$  is increased to exceed the desired use temperature. In general, the cure time and temperature determines the amount of unreacted nadimide endgroups and higher bicyclic compounds which would quantitatively release CPD when pyrolyzed. The postcure temperature and time controls the amount of CPD incorporated into the polymer by further thermal crosslinking and initial thermo-oxidative crosslinking reactions. Finally, the aging temperature and time determine the amount of nadimide endgroups and possibly higher bicyclic compounds that are incorporated into the polymer by further thermal and more thermo-oxidative crosslinking and, now, initial thermo-oxidative degradation reactions. Thus, the extent of crosslinked structure of the polymer chain at any time during these processes determines the amount of CPD available during pyrolysis. The significance of the CPD measurements and the conditions to assure complete CPD evolution during pyrolysis are discussed below. The effects of the variables of pyrolysis temperature, pyrolysis time, and particle size range of the specimen were investigated in order to insure that complete evolution of CPD occurs. The amounts of CPD for staged PMR molding powders are relatively constant over the pyrolysis range of 500 to 900 °C for a pyrolysis time of 10 sec as shown in Figure 1. In order to show that no further evolution of CPD occurs, successive pyrolysis runs on the same PMR molding powder sample were performed at temperatures ranging from 300 to 1000 °C as shown in Figure 2. Thus Figure 2 shows that CPD evolution was complete in the initial 10 sec of 800 °C pyrolysis. In addition single pyrolysis runs at 800 °C were also done for 1 to 20 sec to further show that 10 sec at 800 °C results in the maximum CPD evolution from PMR molding powders. Also PMR molding powders with particle sizes of 74 to 149  $\mu\text{m}$  showed no significant differences in the CPD per  $\mu\text{g}$  of sample evolved on pyrolysis at 800 °C for 10 sec. Thus, the pyrolysis conditions of 10 sec at 800 °C assured the complete evolution of the CPD which is available from the PMR specimens of particle size 74 to 149  $\mu\text{m}$  used in this study.

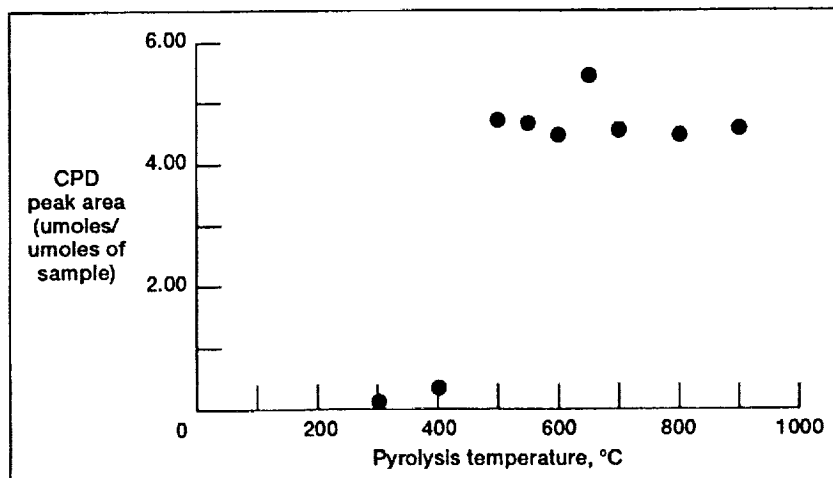

Figure 1.—Effect of pyrolysis temperature at ten second pyrolysis time on CPD evolution for staged PMR-15.



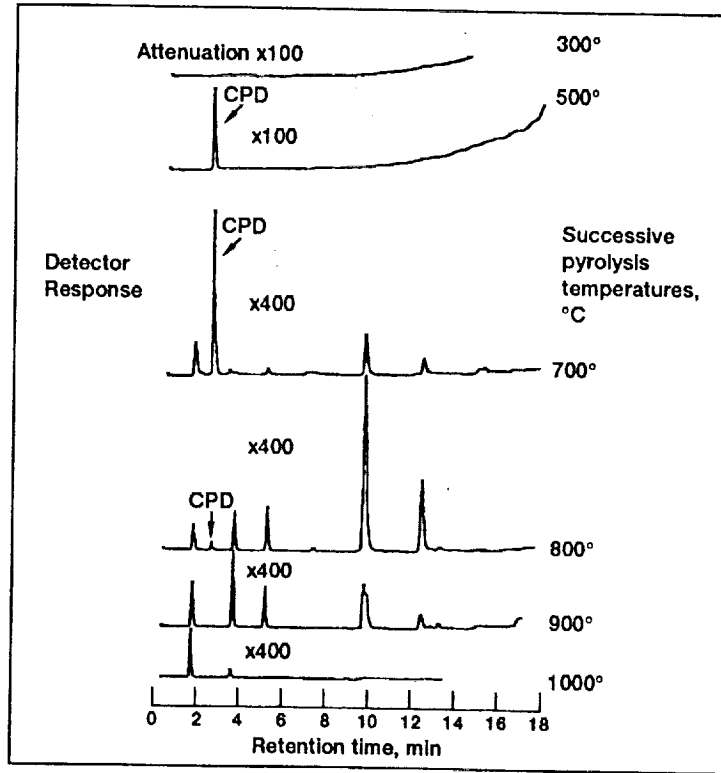

Figure 2.—Successive pyrolysis runs of cured PMR-15.

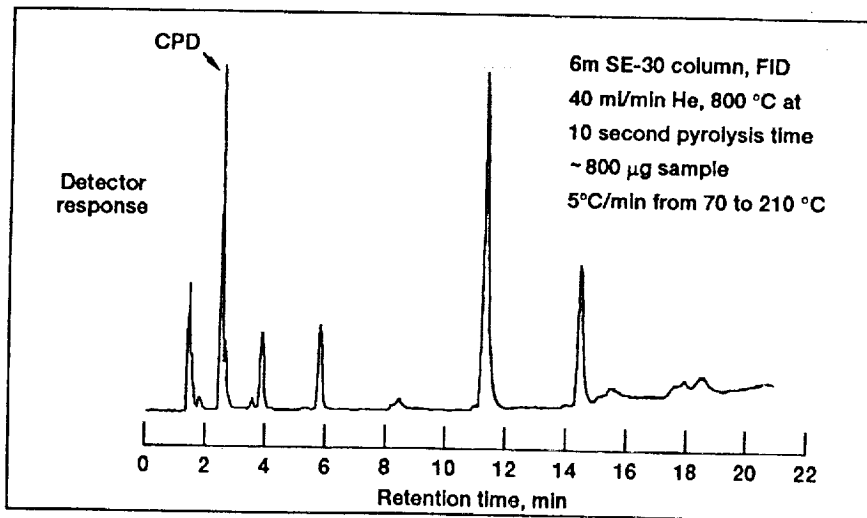

Figure 3.—A typical pyrogram of one hour 316 °C cured PMR-15.

A typical pyrogram of PMR-15 cured at 316 °C for 1 hr and pyrolyzed at these conditions is shown in Figure 3. The first large peak in Figure 3 appears at the same retention time as CPD. The identification of this peak as CPD has been confirmed for the 2NE/MDA model compound and PMR-15 resins using a CDS-pyroprobe joined to a GC-mass spectrometer in the electron ionization mode. The prominent ions of masses 65 and 66 correspond to CPD minus one hydrogen and the molecular ion, respectively. Further investigation is being conducted to determine the identity of the other peaks in the pyrogram.

EFFECT OF FMW ON CPD EVOLUTION—The amounts of CPD from the series of staged (1 hr at 204 °C) and cured (1 hr at 316 °C) specimens including 2NE/MDA, PMR-10, PMR-12.5, PMR-15 and PMR-20 were determined by measuring the chromatographic peak areas of CPD in pyrograms obtained from 10 sec runs at 800 °C. The data, summarized in Table II, are normalized for the available average amount of CPD from staged PMR material expressed as peak area per  $\mu\text{g}$  of sample. Staged material is used as the normalization standard because of the good sample homogeneity and no crosslinking should have thermally occurred, thus insuring quantitative availability of CPD for evolution in the PY-GC procedure.

TABLE II.—CYCLOPENTADIENE  
RELEASE DATA

[ $N_c$  = CPD evolved (normalized to 1.00 as the average from staged PMR material resin).]

Material	$N_c$
2NE/MDA (1 hr/204 °C) staged	0.955
PMR-10 (1 hr/204 °C) staged	1.060
PMR-12.5 (1 hr/204 °C) staged	1.055
PMR-15 (1 hr/204 °C) staged	.970
PMR-20 (1 hr/204 °C) staged	.990
2NE/MDA (1 hr/316 °C) cure	.171
PMR-10 (1 hr/316 °C) cure	.195
PMR-12.5 (1 hr/316 °C) cure	.235
PMR-15 (1 hr/316 °C) cure	<sup>a</sup> .177±.015
PMR-20 (1 hr/316 °C) cure	.157
Isolated crosslink	.058
Polymerized NA	.070

<sup>a</sup>Average deviation from mean, 14 determinations.

Table II shows that the amount of CPD evolved for the cured material is 16 to 24 percent of the staged material for FMW of PMR-10 to PMR-20. This result shows that considerable reaction of norbornenyl endgroups has occurred during the curing of staged material in such a way as to make the CPD relatively unavailable by pyrolysis. It can be speculated that the CPD available after curing evolves mainly from unpolymerized endgroups because of the high efficiency of CPD release in the uncured staged PMR molding powders. Apparently the curing conditions of 316 °C for 1 hr were sufficient to cause the crosslinking reaction to proceed to about the same high degree of advancement (i.e., percentage of norbornenyl groups reacted) for all the compositions studied. As the available crosslink concentration decreases with increasing chain length (increasing FMW), fewer endgroups need to react at the same cure temperature to reach the same extent of cure, thus leaving the same amount of unreacted endgroups as sites for available CPD evolution. It appears that the origin of the CPD obtained from pyrolysis of cured PMR resin is mainly unreacted endgroups (see structure I).

Thus, the amount of CPD obtained from cured resin compared to that from staged resin appears to be a measure of the extent of crosslinking. This is discussed in more detail in connection with the effect of curing temperature on pyrolytically available CPD and their correlation to the glass transition temperature ( $T_g$ ).

**EFFECT OF CURE TEMPERATURE AND CURE TIME ON CPD EVOLUTION**—The amount of CPD evolved ( $N_c$ ) from pyrolysis of cured PMR-15 is shown in Figure 4 as a function of cure temperature. The variable  $N_c$  is defined by the following expression:

$$N_c = \frac{\text{Area of CPD peak per } \mu\text{g of cured specimen}}{\text{Area of CPD peak per } \mu\text{g of staged specimen}} = \begin{array}{l} \text{normalized amount of CPD} \\ \text{for a cured specimen} \end{array}$$

This graph indicates a strong decrease in  $N_c$  as the cure temperature increases. A linear extrapolation to a value of unity for  $N_c$  gives an initial starting temperature for this decrease as approximately 270 °C. This temperature agrees well with the value of 275 °C reported [11,20] as the temperature of initiation for the reverse Diels-Alder

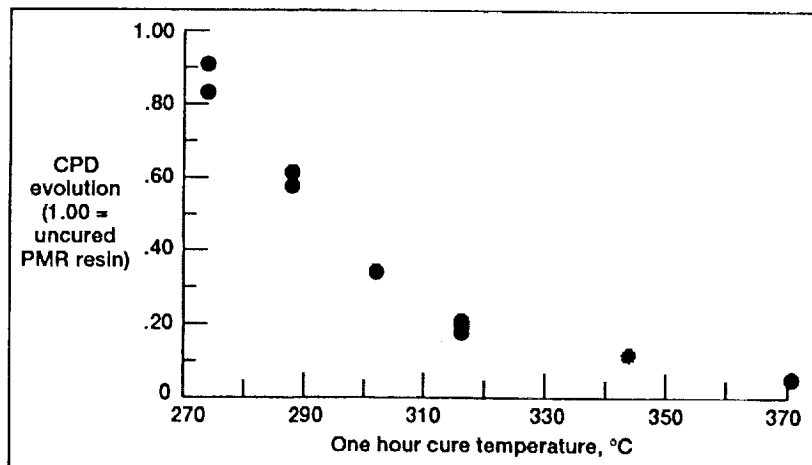

Figure 4.—CPD evolved ( $N_c$ ) for PMR-15 as a function of one hour at cure temperature.

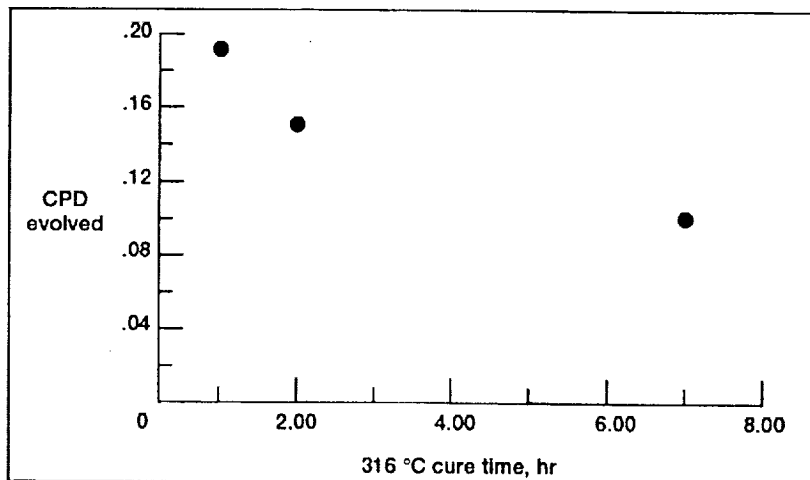

Figure 5.—CPD evolved ( $N_c$ ) for PMR-15 as a function of 316 °C cure time.

reaction. From the information on CPD evolution given in Figure 4, the norbornenyl endgroup reaction is more than 80 percent complete for a resin cured for one hour at 316 °C. The amount of CPD available for evolution continues to decrease with increasing cure time from 19 percent after 1 hr of 316 °C curing to 11 percent after 7 hr of 316 °C curing as shown in Figure 5.

**EFFECT OF CURE TEMPERATURE ON  $T_g$** —The glass transition temperature of PMR-15 increases nonlinearly with an increase in the cure temperature as shown in Figure 6. However, when  $N_c$  is graphed in a correlation plot as a function of  $T_g$  for PMR-15, an excellent linear correlation is obtained as shown in Figure 7. Because  $T_g$  is an indication of the extent of cross-linking for lightly crosslinked systems, this correlation is interpreted to mean that the decrease in the CPD evolved is a measure of the extent of crosslinking. If it is assumed that (1) all the CPD in the staged resin can be evolved on pyrolysis, (2) no significant crosslinking occurs during the rapid heating to the 800 °C pyrolysis temperature, and (3) the  $T_g$  does not increase during the 20 °C/min heatup in the TMA analysis; then the change in the CPD evolution can be used to estimate the extent of curing for the PMR resins.

**EFFECT OF AGING TEMPERATURE ON CPD EVOLUTION**—In addition to cure time and cure temperature, the effects of aging temperature and aging time (explained in next subsection) on the CPD evolved during pyrolysis were determined for PMR-15 (originally cured at 316 °C for 1 hr). Weight loss measurements were also performed after 1 hr air exposure at various temperatures and after extended aging in 316 °C air by periodically removing the powder samples from the isothermal air aging ovens and weighing the samples at room temperature. The amount of CPD evolved ( $N_a$ ) from pyrolysis of aged PMR-15 is shown in Figure 8 as a function of aging temperature for 1 hr air exposure. The variable  $N_a$  is defined by the following expression and was used to normalize the CPD evolved during pyrolysis to the  $N_c = 1.0$  of staged resin specimens. The value of  $N_a$  is always less than  $N_c = 0.18$  for 1 hr at 316 °C cured PMR-15.

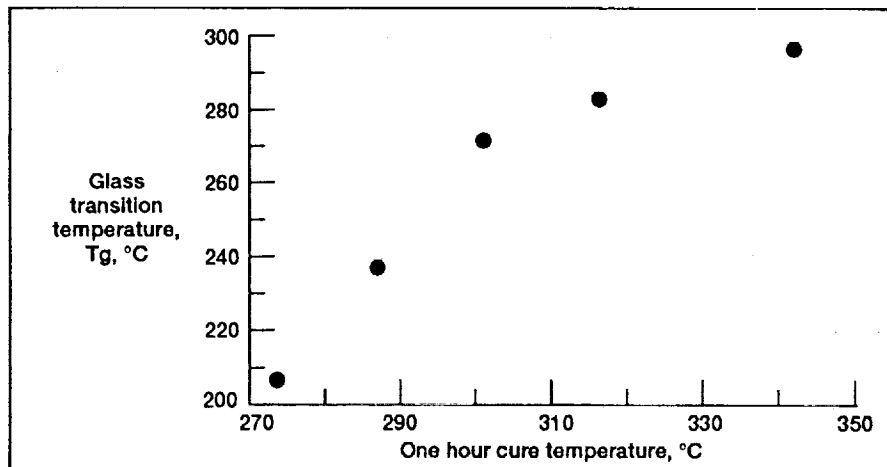

Figure 6.—Glass transition temperature ( $T_g$ ) of PMR-15 as a function of one hour at cure temperature.

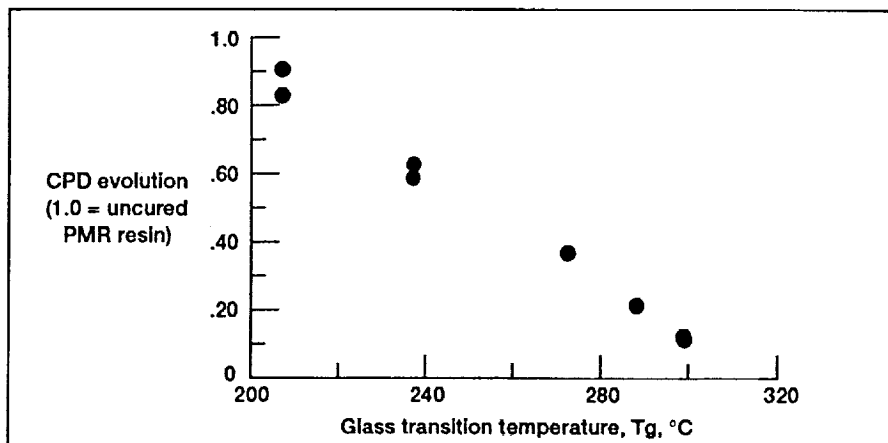

Figure 7.—Correlation of CPD evolved ( $N_c$ ) with glass transition temperature ( $T_g$ ) for PMR-15.

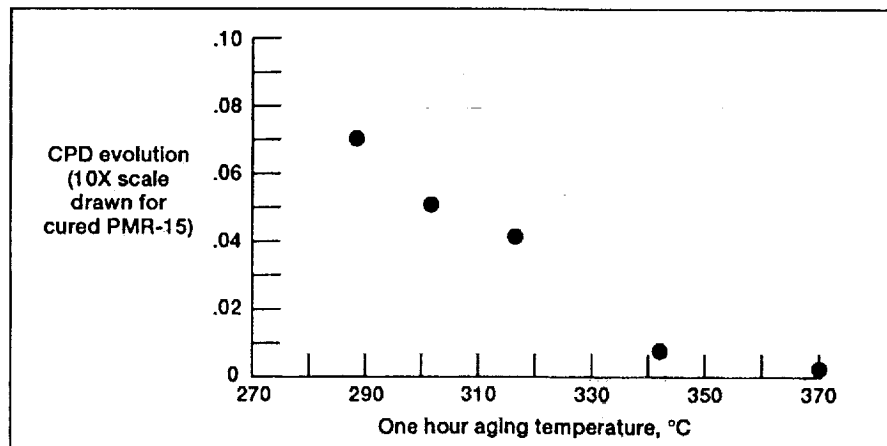

Figure 8.—CPD evolved ( $N_a$ ) for one hour 316 °C cured PMR-15 as a function of one hour air aging temperature.

$$N_a = \frac{\text{Area of CPD peak per } \mu\text{g of aged specimen}}{\text{Area of CPD peak per } \mu\text{g of staged specimen}} = \text{normalized amount of CPD for aged specimen}$$

This graph indicates  $N_a$  decreases linearly with increasing aging temperature, such that after 1 hr in 343 °C air, only 0.8 percent of the CPD originally available in staged resin can be evolved on pyrolysis. For an increased aging temperature of 1 hr in 371 °C air, the CPD evolution effectively approaches zero as  $N_a$  drops to 0.0002 (0.02 percent). Of course, the release and/or reaction of CPD during aging will be influenced by the specimen geometry because of mass and heat transport processes, as well as by the aging temperature.

Similarly, the percentage weight loss of PMR-15 as a function of aging temperature for 1 hr air exposure is shown in Figure 9. Although the value  $N_a$  does change significantly over the same temperature range as shown in Figure 8, the weight loss shown in Figure 9 does not begin to appreciably change until the air aging temperature is somewhat higher (288 versus 316 °C). Thus, there does not appear to be a linear correlation between the CPD evolved ( $N_a$  in Figure 8) and the weight loss observed (in Figure 9) as the air aging temperature is varied.

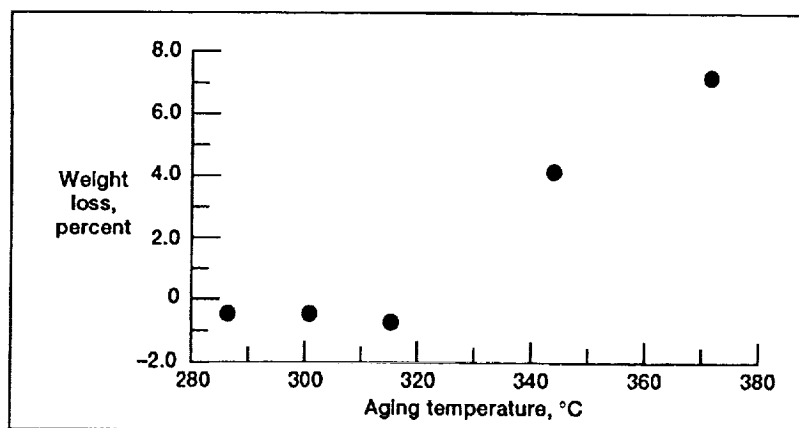

Figure 9.—One hour percent weight loss of one hour 316 °C cured PMR-15 as a function of air aging temperature.

**EFFECT OF AGING TIME ON CPD EVOLUTION**—The decrease in CPD evolved ( $N_a$ ) from cured PMR-15 as a function of aging time in air at 316 °C is shown in Figure 10. The decrease is quite rapid during about the first 3 hr of aging in 316 °C air as seen in both Figure 10 and the expanded  $N_a$  scale also shown in Figure 10. However, the percent weight loss during the first 3 hr of 316 °C air aging is less than 3 percent as shown in Figure 11. After 24 hr of aging in 316 °C air, it appears that only a small additional amount of CPD is evolved (Figure 10) during pyrolysis while the corresponding resin weight loss has increased to about 13 percent (Figure 11). Thus, percent weight loss (Figure 10) and CPD evolution ( $N_a$  in Figure 11) do not appear to be correlated. However, it must be noted these weight losses are for aging of the PMR-15 sieved powder,

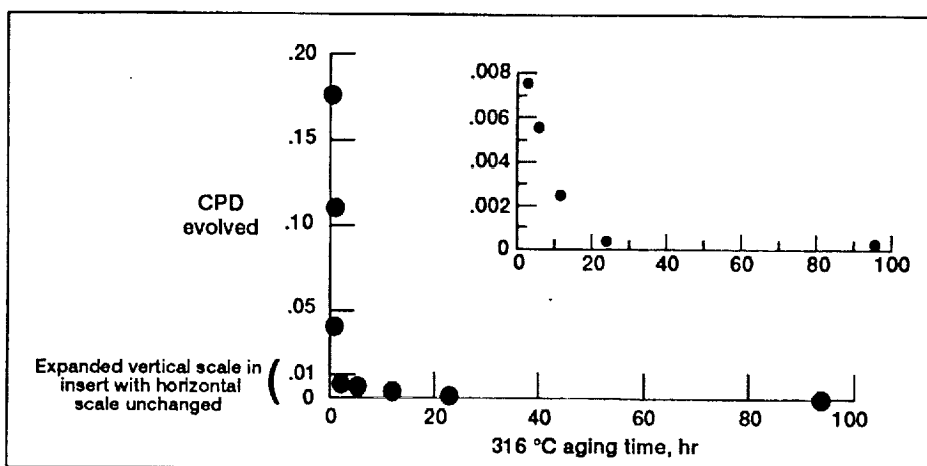

Figure 10.—CPD evolved ( $N_a$ ) of one hour 316 °C cured PMR-15 as a function of aging time in 316 °C air.

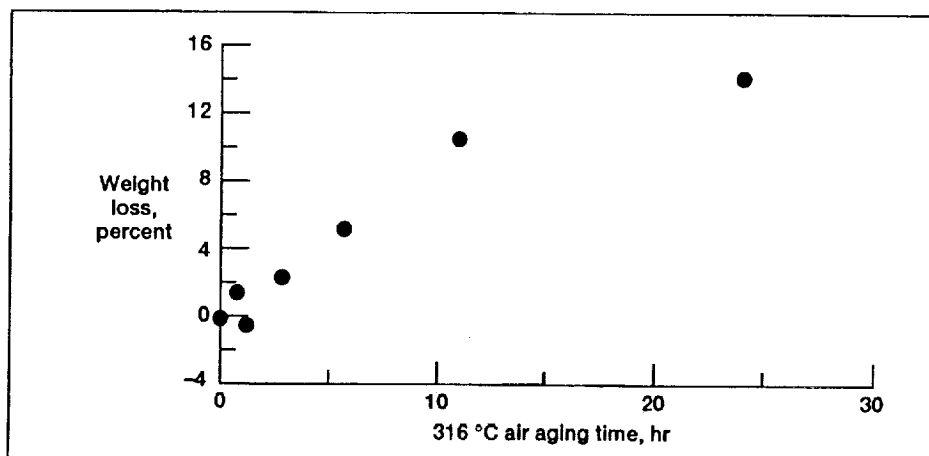

Figure 11.—Percent weight loss of one hour 316 °C cured PMR-15 as a function of aging time in 316 °C air.

thus the percent weight losses are excessive compared to weight losses for bulk PMR-15 neat resin. The corresponding weight losses for bulk PMR-15 neat resin are 1.9 to 2.1 percent during a 16 hr postcure in air [21] which agrees with the rapid 3 hr powder weight loss of less than 3 percent. However, the bulk weight loss of 3.1 to 3.4 percent (including the 1.9 to 2.1 percent postcure weight loss) after an initial 90 hr of 316 °C air postcure plus aging [21] is considerably less than the 13 percent (10 percent plus 3 percent at 3 hr aging) found after 24 hr of 316 °C aging for PMR-15 powder. At 24 hr of exposure the available CPD for evolution is now 20 times less than after 3 hr when the rapid drop in CPD evolution had finished (Figure 10). Interestingly, the 13 percent weight loss does, however, approximately agree with the weight loss of resin during the useful life of a composite [22].

From all this data, it could be speculated that the region of rapid change of CPD evolution (first 3 hr aging in Figure 10) may correspond to the postcuring step employed in processing composites and may be attributed to actual loss of CPD during postcuring.

Support for this speculation is seen in the postcure weight loss of bulk PMR-15 neat resin is 1.9 to 2.1 percent while the powdered PMR-15 rapid weight loss region is less than 3 percent (see Figure 11); compared to the theoretical weight loss calculated to be 1.55 percent for  $N_a$  decreasing from 0.177 to 0.01 (see Figure 10). This calculated value is invariably slightly less than the observed postcure weight loss, suggesting additional processes besides potential loss of CPD as  $N_a = 0.177$  drops to 0.01 could be involved in postcure weight losses. In fact, the postcure weight losses could actually be entirely due to weight losses other than from CPD evolution; which is shown to be the real situation. Figure 1 shows CPD is not available for evolution via PY-GC at 300 °C and mass spectrometry (MS) data [23] shows CPD evolution is not occurring in an air postcure until 370 °C, hence 316 °C air postcure weight loss is not due to CPD evolution. The MS, thermal gravimetric analysis (TGA) and simultaneous TGA-MS results [23] also all show that the weight losses observed in a 316 °C air postcure are due to loss of water and methanol, rather than loss of CPD. Thus it is only coincidental that theoretical weight loss of CPD available for evolution via PY-GC is in the same weight range as that observed in postcuring PMR-15 bulk neat resin. Last, additional CPD evolution data [23] does show, however, that CPD evolution at 316 °C postcure in the absence of air is observed, while 371 °C postcure in air is needed to find CPD evolution via MS. The PY-GC results in Figures 1 and 2 also say CPD evolution is not seen at 300 °C but observed at 400 °C. Hence there is not a direct correlation of CPD evolution via PY-GC and postcure or aging weight losses, but the molecular changes responsible for the availability of CPD for evolution do correspond (but not linearly correlate) to the time frame during which postcure weight losses occur. Aside from this, it is further speculated that the later region of slower change of CPD evolution (beyond 3 hr aging in Figure 10) may correspond (but not linearly correlate) to long term thermo-oxidative degradation aging. Thus, by using accurate aged PMR standards and obtaining accurate reproducible PY-GC data, one could potentially characterize the extent of long-term PMR resin degradation by developing an empirical correlation curve of CPD evolution to aging time that would be similar to that done in Figure 10.

**COMPARATIVE EFFECT OF CURING TIME VERSUS AGING TIME ON CPD EVOLUTION**—The comparative effect of additional time spent at high temperatures in various environments (beyond the 1 hr 316 °C cure temperature) on CPD evolution is shown in Figure 12. The effect of added 316 °C cure time spent in a heated closed mold on subsequent CPD evolution is replotted from Figure 5 as a function of added hours (0, 1, and 6 hr) at 316 °C after the initial 1 hr 316 °C cure time; shown as the upper line in Figure 12. The effect of 316 °C aging time spent in an open air environment (instead of a closed mold) on subsequent CPD evolution is replotted from Figure 10 as a function of aging time in 316 °C air up to 96 hr after the initial 1 hr 316 °C cure time; shown as the lower line in Figure 12. Although both curves show added time at 316 °C results in a reduction in CPD evolution, the comparison of the two curves shows that the reduction in CPD evolution after 316 °C air aging is much greater than after added 316 °C curing time in a closed mold. Some of this difference is undoubtedly due to the method of PMR-15 sample preparation; the upper line being for bulk cured PMR-15 in a closed mold while the lower line being for sieved PMR-15 powder prepared from bulk cured PMR-15. The greater surface-to-volume area of the PMR-15 powder would assumedly



accelerate the reduction in  $N_a$  shown in Figure 12. It is assumed that the  $N_a$  values of aged powder would probably be closer to the  $N_a$  obtained at the surface of aged bulk PMR-15 and consequently, would be averaged higher if sampling were done throughout the thickness of aged bulk PMR-15. Because this data does not have a good empirical correlation between the  $N_a$  for aged PMR-15 powder and the corresponding  $N_a$  for bulk aged PMR-15, it is possible the 96 hr of aging on PMR-15 sieved powder could be equivalent to the total useful lifetime of bulk PMR-15 when properly sampled throughout its thickness.

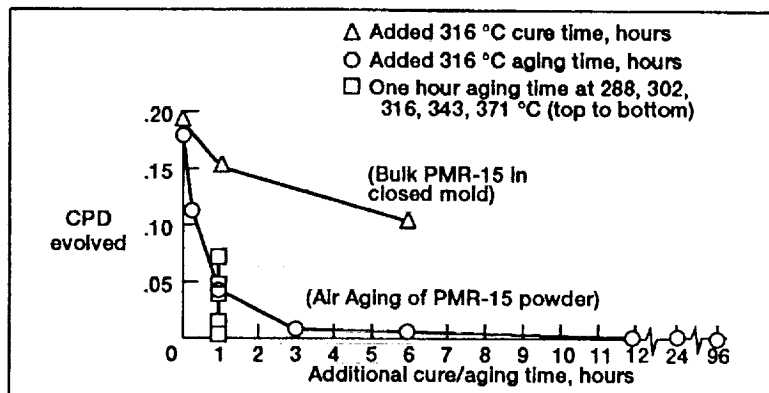

Figure 12.—CPD evolved ( $N_c$  or  $N_a$ ) for one hour 316 °C cured PMR-15 as a function of additional 316 °C cure time or air aging time at 288 to 371 °C.

Nevertheless, the trend of a lower  $N_a$  in air aging versus the  $N_c$  in a closed mold is in total agreement with the recent report [23] that CPD evolution in PMR-15 composite can be detected via MS and TGA-MS during extended 316 °C curing in a vacuum bag, but could not be detected in a 316 °C postcure in air. Clearly the presence of air affects the mechanisms by which CPD evolution is rapidly retarded in postcuring. These observations also agree with the need to do postcures in an air oven to advance the  $T_g$  in normal manufacturing processes. Unfortunately the molecular processes occurring during cure and postcure have never been fully explained, so this insight becomes a significant clue to explain the cure/postcure study chemistry of PMR polyimides.

This enhanced effect of reduced CPD evolution after the air aging also occurs over a wide range of aging temperatures; shown in Figure 12 as the vertical line (data replotted from Figure 8) of CPD evolution after 1 hr of air aging as a function of aging temperature. This vertical line shows that after only 1 hr of 371 °C air exposure, PMR-15 ages to where CPD evolution becomes virtually nonexistent (0.02 percent,  $N_a = 0.0002$  after only 1 hr air aging at 371 °C). This strongly suggests that the PY-GC technique would be of limited analytical value to characterize or identify PMR-15 samples where extremely extended postcure schedules have been done, such as the 25 hr/371 °C postcure in air investigated in an earlier effort [24] to develop 371 °C (700 °F) use temperatures.

In contrast, the normal, less extensive postcure cycle for PMR-15 is the first 16 hr of 316 °C air exposure after 1 to 2 hr of 316 °C curing. The CPD available for evolution after this normal postcure is about 0.1 percent at the 16 hr air aging time on the lower curve where  $N_a = 0.001$  in Figure 12. Although smaller  $N_a$  values (0.0002) were detectable for up to 96 hr of 316 °C air aging via PY-GC techniques, the very small  $N_a$

values do suggest that the PY-GC technique may be near the practical limits of obtaining useful PMR-15 characterization information. More recent developments in efforts to advance the  $T_g$  of PMR-15 entails postcuring in 371 °C nitrogen after the traditional 16 hr postcure in 316 °C air [25]. It is expected nitrogen postcuring at 371 °C would further crosslink PMR-15 to beyond a point at which PY-GC may be useful because the lower curve in Figure 12 indicates  $N_a$  is already down to 0.001 after 16 hr of 316 °C air aging (normal postcure) when nitrogen postcuring at 371 °C is then initiated. Thus, it is not predicted that PY-GC would be a viable technique to determine the extent of nitrogen postcuring or extended aging time that PMR-15 samples have undergone, but rather PY-GC is a useful technique to determine the extent of cure or air postcure of PMR-15 samples. However, the data does not rule out that PY-GC could be used to determine the extent of long term air aging because the low  $N_a$  values after long-term aging are from sieved PMR-15 powder, rather than bulk PMR-15. The  $N_a$  for aged PMR-15 bulk samples would assumedly be higher, but was not characterized. Thus the  $N_a$  could easily be higher than shown in Figures 10 and 12 such that PY-GC could still be a valid technique to characterize long term aged PMR-15 bulk samples. However, this technique requires a reproducible and meaningful sampling technique that takes into account the overall PMR-15 thickness and the depth of the thermo-oxidative degradation as a function of aging time or useful lifetime.

CPD EVOLUTION FROM EXTRACTED CROSSLINK AND POLYMERIZED NA—Analogous structures to II, III, IV could be suggested for the crosslinker isolated by hydrazine hydrate digestion from cured 2NE/MDA. These structures are identical to II, III, and IV except they vary in the functional groups on the crosslinks (believed to be mixtures of the N-aminoamide acid and the N-aminoimide) isolated by the hydrazine digestion procedure described earlier [8-10]. In the case of polymerized NA described, the functional groups are believed to be anhydrides.

The pyrograms obtained from the isolated crosslink and the polymerized NA were qualitatively identical as shown in Figure 13. Furthermore, the 2NE/MDA pyrogram was also qualitatively identical to that obtained for PMR-15 shown in the top of Figure 14. Therefore, the pyrolysis products originating from the crosslinker itself appear to be the major products in the pyrogram of PMR-15. Thus, the CPD peak in these pyrograms contain the evolved CPD from the crosslinker and, in addition, also any CPD from unreacted endgroups.

The amounts of CPD evolved from isolated crosslinker and from polymerized NA are approximately equal, both have  $N_c$  approximately 0.06 when normalized to the staged resins (1.0) as reported in Table II. This result indicates that some of the CPD does originate from chain cleavage of structures II, III, IV or from polymerized nadic anhydride followed by a reverse Diels-Alder reaction to yield CPD. Table II shows that the cured model compound 2NE/MDA and cured PMR-15 both have a  $N_c$  value of approximately 0.18 for CPD. Thus one could conclude that approximately 2/3 of the CPD evolution is from unreacted endgroups and 1/3 is potentially from the degradation of polymerized endgroups. This observation agrees with data obtained for the isolation of crosslinker because 64 percent of the crosslinker was not recovered in the isolation procedures (assuming that the lower molecular weight materials, which readily evolve

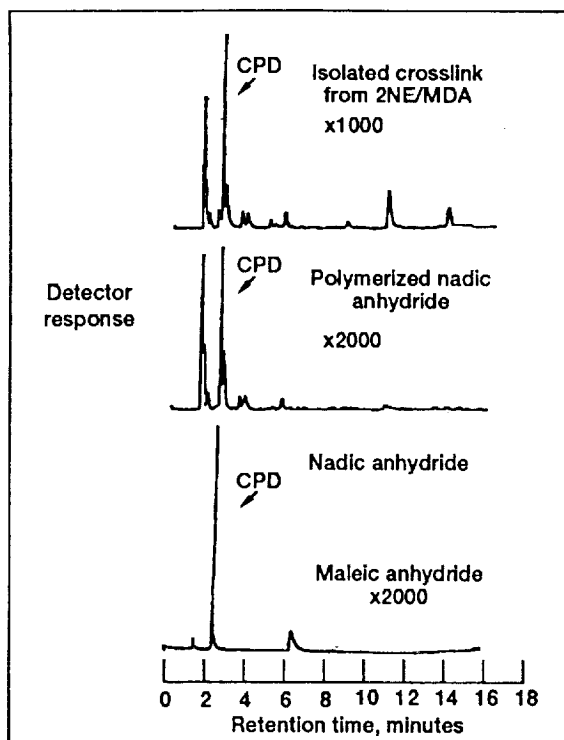

Figure 13.—Pyrograms of crosslink, poly-nadic anhydride, and nadic anhydride.

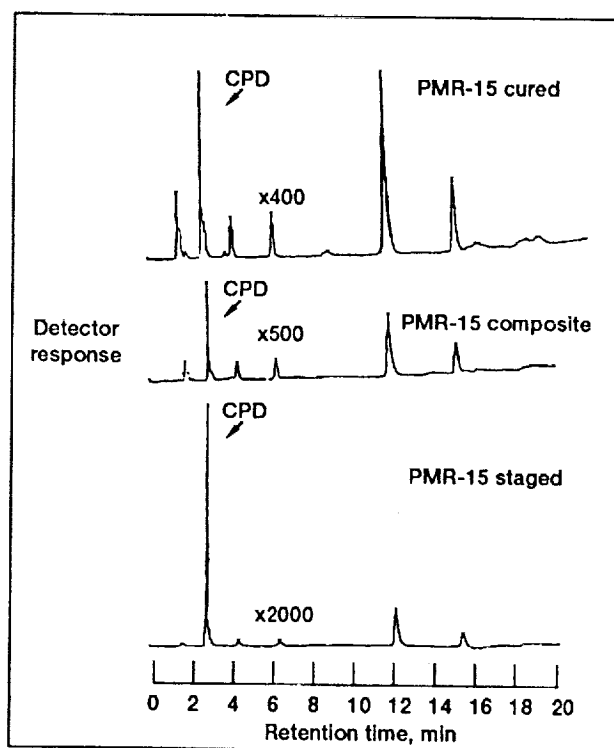

Figure 14.—Pyrograms of PMR-15 resins and PMR-15 composite with HTS graphite fiber.

CPD, were not contained in the isolated crosslinker as they pass through the  $10^3$  molecular filter). Hence the lower value of 0.06 for  $N_c$  is easily explained.

**CPD EVOLUTION RELATED TO EXTENT OF REACTION**—An estimate of the extent of reaction of norbornenyl endgroups for cured 2NE/MDA has been made by assuming the following: (1) a quantitative amount of CPD results from pyrolysis of staged 2NE/MDA; (2) for cured (1 hr at 316 °C) 2NE/MDA, a portion of the norbornenyl groups which reacted to form crosslinks and other products resulted in  $N_c = 0.171$  for CPD; and (3) the reacted portion which formed crosslinker will give a fractional yield of  $N_c = 0.058$  of CPD on pyrolysis (Table II), and the unreacted endgroups (which would give a quantitative yield of  $N_c = 1.0$  for CPD) would account for the difference of 0.122 since 2NE/MDA yields a value of 0.18 for  $N_c$ . Thus, 88 percent of the norbornenyl endgroups reacted in curing of 2NE/MDA for 1 hr at 316 °C in a closed mold. For PMR-15, a similar material balance, gives the expression:  $0.06F + 1.0(1 - F) = 0.18$ , where  $F$  is the fraction of norbornenyl endgroups which have reacted to form crosslink, and 0.18 is the fractional CPD amount from cured 2NE/MDA. If the material balance is calculated using 0.177 for CPD in PMR-15, the fraction of endgroups reacted is 87 percent. It should be noted that this does not imply that 87 percent of the norbornenyl endgroups have undergone a reverse Diels-Alder reaction. Rather, it means that a significantly lesser amount of the reverse Diels-Alder reaction, which generates the rate determining polymerization maleimide concentration [19], has occurred. The generated maleimide in turn reacts with an equal to or greater amount of olefins in norbornenyl endgroups resulting in 87 percent of the original endgroups are changed in that CPD is

no longer available for evolution. The amount of norbornenyl endgroups consumed is only equal to the amount of maleimide generated via reverse Diels-Alder reaction for alternating copolymerization of maleimide with CPD (structure II) and is also only equal for the homopolymerization of nadimides (structure III). However, only with the formation of higher bicyclics via Diels-Alder reactions of nadimide plus CPD is a mechanism seen to consume up to two norbornenyl groups per maleimide generated (structure IV). Only with this type of rationale of the incorporation of additional CPD into structures such as IV is it possible to explain how the isolation of only 36 percent of the crosslinker, with a molecular weight exceeding the  $10^3$  Millipore filter cutoff, could still only account for 6 percent ( $N_c = 0.058$ ) CPD evolution. This means the extra CPD formed when maleimide is generated via the reverse Diels-Alder reaction needs to be tied up into structures that cannot regenerate nadimide endgroups (which would quantitatively evolve CPD like staged PMR resin) via depolymerizations such as unzipping. Only structures such as IV fit these requirements.

**UTILITY OF PY-GC TECHNIQUE**—The significance of this study should not be overlooked as it would be possible to characterize scrap PMR-15 removed during manufacturing processes (drilling, machining operations, etc.). These samples could be used to determine the state of cure/postcure of a PMR-15 structure being fabricated via PY-GC characterization without destructively sampling the finished part. However, the determination of whether a finished PMR part in actual service is approaching the end of its useful lifetime at elevated temperature appears to be beyond the scope of the PY-GC technique at this time due to the minimal amount of CPD available with extended aging.

From a different viewpoint, the PY-GC technique does offer an analytical approach to determine the extent of cure, postcure and long term aging of PMR resin at a service temperature by analyzing CPD evolution over four orders of magnitude. The first order of magnitude covers 100 to 10 percent CPD evolution for analysis of the cure state; the next two orders of magnitude covers 10 to 0.1 percent CPD evolution for analysis of the postcure state; while the fourth and any higher orders of magnitude covers 0.1 to 0.01 percent CPD evolution and less for extended high temperature aging. However, the sampling variables may create too much data scatter for the accurate and precise PY-GC analysis to be useful for dating aged PMR parts of CPD evolution  $<0.1$  percent. Thus, the authors feel verifying the extent of cure and postcure via CPD evolution is the practical limit of useful information. Even with a greatly increased sensitivity of a different analytical techniques, such as MS, TGA-MS, PY-GC-MS, the dating of aged PMR would still be limited by the data scatter. This is because the sampling of microgram amounts of PMR from structures potentially weighing many kilograms can not be done in a meaningful statistical and representative fashion.

## SUMMARY OF RESULTS AND CONCLUSIONS

The amount of cyclopentadiene (CPD) evolved by pyrolysis at 800 °C for 10 sec for polymerization of monomeric reactants (PMR) resins, model compounds, and composites were studied. It was determined that:

1. The amount of CPD evolved from staged PMR resins decreases with increasing formulated molecular weight (FMW). However, the normalized amount of CPD evolved divided by the FMW is constant and hence dependent only on the initial concentration of norbornenyl endgroups.

2. The amount of CPD evolved from cured PMR resins decreases with increasing cure temperature and time, increasing aging temperature and time, and increasing resin glass transition temperature. A linear correlation was found for CPD evolved from cured PMR resins versus glass transition temperature ( $T_g$ ).

3. The amount of CPD released from addition crosslinked PMR resin (as measured by pyrolysis-gas chromatography, PY-GC) is inversely related to the fraction of norbornenyl groups that reacted to form crosslinks during the curing process. By extrapolation of the data for evolved CPD as a function of temperature, it was determined that the onset cure temperature for PMR-15 is  $270 \pm 5$  °C.

4. A numerical estimate of the fraction of norbornenyl groups reacted in PMR resin can be derived using the amounts of CPD evolved on pyrolysis of staged resin, cured resin, aged resin, and isolated crosslink material. For example, PMR-15 resin was calculated to contain approximately 13 percent unreacted endgroups after 1 hr cure time at 316 °C.

5. The amount of CPD available from postcured PMR (as measured by PY-GC) rapidly decreased during the initial thermo-oxidative degradation (postcure process). However, significantly more CPD was available in PMR-15 if postcuring was done only in a nonoxidative environment. This clearly indicates air is involved in the postcure mechanism of PMR-15.

6. The amount of CPD available from aged PMR (as measured by PY-GC) slowly further decreased with increasing extent of thermo-oxidative degradation (aging) time. Thus, PY-GC potentially could be used to determine the extent of resin degradation, but the continually decreasing small amount of CPD evolution may be insufficient to accurately correlate with long-term aging.

7. The CPD evolution results combined with other literature results strongly suggest the correct polymerization mechanism is an alternating copolymerization of maleimide (formed via reverse Diels-Alder reaction) with olefins from unreacted nadic endgroups and olefins from higher bicyclics (from reaction of Nadics with CPD). The historical and widely published mechanisms are very likely to be incorrect.

8. The pyrograms obtained from graphite fiber reinforced PMR composites are qualitatively the same as pyrograms obtained from the PMR-15 resin. This result indicates that PY-GC can be used to characterize cured, postcured and aged PMR composites (as well as resins) for the degree of cure and postcure and potentially even the extent of thermo-oxidative degradation. The obvious application of this result could be to determine if a PMR-15 fabricated part was completely cured/postcured. This determination would use PY-GC analysis of PMR samples normally removed during the manufacturing operations of fabricated PMR-15 composites.

## ACKNOWLEDGMENTS

The authors gratefully acknowledge the assistance of Bucknell students, Craig Lack, Robert Jerman, Lynn and Thorne Duncan, and Vicki Sholtes. Also the faculty and students of Bucknell acknowledge the assistance of NASA Lewis Research Center for financial support and the use of equipment which made this project possible. W.J. Snyder gratefully acknowledges the assistance and collaboration with Dr. Richard E. Gluyas as his mentor under the NASA-ASEE Summer Faculty Program, Dr. William B. Alston for his valuable assistance in completing this project, and Dr. Richard W. Lauver for his excellent technical advice.

## REFERENCES

1. Serafini, T.T., P. Delvigs, and G. Lightsey, 1972. "Thermally Stable Polyimides from Solutions of Monomeric Reactants." NASA TND-6611.
2. Delvigs, P., T.T. Serafini, and G. Lightsey, 1972. "Addition-Type Polyimides from Solutions of Monomeric Reactants." NASA TND-6877. (Also NASA TMX-68011, Apr. 1972.)
3. Serafini, T.T., P. Delvigs, and W.B. Alston, 1982. "PMR Polyimides-Review and Update." NASA TM-82821. AVRADCOM TR 82-C-3. Also Proceedings of 27th National SAMPE Symposium, "Materials Overview for 1982," Vol. 27, pp. 320-325, May 4-6, 1982.
4. Wilson, D., 1988. "PMR-15 Processing, Properties and Problems—A Review." British Polymer Journal, 20:405-416.
5. Cavano, P.J., 1974. "Resin/Graphite Fiber Composites." NASA CR-121275. (Also, NASA CR-134727, Dec. 1974.)
6. Jones, C.E.R. and C.A. Cramers, 1977. Analytical Pyrolysis. Elsevier Scientific Publishing Company.
7. Berezkin, V.G., V.R. Alisheyev, and I.B. Nemirovskaya, 1977. Gas Chromatography of Polymers. Elsevier Scientific Publishing Company.
8. Jones, J.I., 1969. "The Reaction of Hydrazine with Polyimides, and its Utility." Journal of Polymer Science, 22:773-784.
9. Dine-Hart, R.A., D.B.V. Parker, and W.W. Wright, 1971, "Oxidative Degradation of a Polyimide Film—II. Studies Using Hydrazine Hydrate." British Polymer Journal, 3:226-234.
10. Alston, W.B., 1980. "Characterization of PMR-15 Polyimide Resin Composition in Thermo-Oxidatively Exposed Graphite Fiber Composites." NASA TM-81565. AVRADCOM TR-80-C-10. (Also SAMPE Journal, 17:5-13, 1981.) Also 12th National SAMPE Conference Proceedings, "Materials 1980," Vol. 12, pp. 121-135, October 7-9, 1980.
11. Burns, E.A., R.J. Jones, R.W. Vaughan, and W.P. Kendrick, 1970. "Thermally Stable Laminating Resins." NASA CR-72633.
12. Jones, R.J., R.W. Vaughan, and E.A. Burns, 1972. "Thermally Stable Laminating Resins." NASA CR-72984.
13. Hay, J.N., J.D. Boyle, S.F. Parker, and D. Wilson, 1989. "Polymerization of N-phenylnadimide: A Model for the Crosslinking of PMR-15 Polyimide." Polymer, 30:1032-40.
14. Vijayakumar, C.T. and K. Lederer, 1989. "Structural Aspects of Polyimides. I. Polymerization and Degradation of Endo-N-Phenylnadimide and Endo-N- Isobutylnadimide." Journal of Polymer Science, Polymer Chemistry, 27:2723-2748.

15. Wilson, D., J.K. Wells, J.N. Hay, D. Lind, G.A. Owens, and F. Johnson, 1987. "Preliminary Investigations into the Microcracking of PMR-15 Graphite/ Composites—Part I, Effect of Cure Temperature. SAMPE Journal, 23:35-42. Presentation of Conference Proceedings of 18th International SAMPE Technical Conference, Vol. 18, pp. 242-253, Seattle, WA, Oct. 7-9, 1986.
16. Wong, A.C. and W.M. Ritchey, 1981. "Nuclear Magnetic-Resonance Study of Nonbornene End-Capped Polyimides. 1. Polymerization of N-Phenylnadimide." Macromolecules, 14:825-831.
17. Wong, A.C., A.N. Garroway, and W.M. Ritchey, 1981. "Nuclear Magnetic Resonance Study of Norbornene End-Capped Polyimides. 2. Solution and Solid-State C-13 Study of 2NE-MDA and PMR Polymerization." Macromolecules, 14:832-836.
18. Wong, A.C. and W.M. Ritchey, 1980. "The Endo-Exo Isomerization of N-Phenyl-5-Nonbornene-2,3-Dicarboximide." Spect. Lett., 13:503-508.
19. Lauver, R.W., 1985. "Chemical Control of Rate and Onset Temperature of Nadimide Polymerization." High Temperature Polymer Matrix Composites, NASA CP-2385, pp. 137-149. Lauver, R.W., 1984-1985. "Chemical Approach for Controlling Nadimide Cure Temperature and Rate with Maleimide." U.S. Patent No.'s 4,497,939; 4,497,948; 4,497,940; 4,455,418; 4,495,339; and 4,514,557.
20. Lauver R.W., 1979. "Kinetics and Imidization of Crosslinking in PMR-Polyimide Resin." Journal of Polymer Science, Polymer Chemistry Edition, 17:2529-2539. Also NASA TM-78844, Oct. 1977.
21. Alston, W.B., 1986. "Structure-to-Property Relationships in Addition Cured Polymers. I.—Thermo-oxidative Stability of Norbornenyl Cured Polyimide Resins. American Chemical Society Polymer Preprints, 27:410-411. (Also AVSCOM TR 86-C-35, Oct. 1986.)
22. Alston, W.B., 1979. "Resin/Fiber Thermo-Oxidative Interactions in PMR Polyimide/ Graphite Composites." NASA TM-79093. AVRADCOM TR 79-6, May 1979. Also 24th National SAMPE Symposium and Exhibition, "The Enigma of the Eighties: Environment, Economics, Energy," Vol. 24, pp. 72-82, May 8-10, 1979. Also Polymer Composites, Vol. 1, No. 2, pp. 66-70 (1980).
23. Simpson, M., P.M. Jacobs, and F.R. Junes, 1991. "Generation of Thermal Strains in Carbon Fiber-Reinforced Bismaleimide (PMR-15) Composites. Part 3: A Simultaneous Thermo-gravimetric Mass Spectral Study of Residual Volatiles and Thermal Microcracking." Composites, 22:105-112.
24. Pater, R.H., 1985. "Rheological, Processing and 371 °C Mechanical Properties of Celion 6000/N-Phenylnadimide Modified PMR Composites." High Temperature Polymer Matrix Composites. NASA CP-2385, pp. 243-256.
25. Bowles, K.J., 1988. "A Thermally Modified Polymer Matrix Composite Material With Structural Integrity to 371 °C." NASA TM-100922. Also 20th International SAMPE Technical Conference Proceedings, "Materials-Processes: The Intercept Point," Vol. 20, pp. 552-561, Sept. 27-29, 1988.

# REPORT DOCUMENTATION PAGE

Form Approved  
OMB No. 0704-0188

Public reporting burden for this collection of information is estimated to average 1 hour per response, including the time for reviewing instructions, searching existing data sources, gathering and maintaining the data needed, and completing and reviewing the collection of information. Send comments regarding this burden estimate or any other aspect of this collection of information, including suggestions for reducing this burden, to Washington Headquarters Services, Directorate for Information Operations and Reports, 1215 Jefferson Davis Highway, Suite 1204, Arlington, VA 22202-4302, and to the Office of Management and Budget, Paperwork Reduction Project (0704-0188), Washington, DC 20503.

<b>1. AGENCY USE ONLY (Leave blank)</b>		<b>2. REPORT DATE</b> 1992	<b>3. REPORT TYPE AND DATES COVERED</b> Technical Memorandum	
<b>4. TITLE AND SUBTITLE</b> Cyclopentadiene Evolution During Pyrolysis-Gas Chromatography of PMR Polyimides			<b>5. FUNDING NUMBERS</b>  WU-510-01-50 1L161102AH45	
<b>6. AUTHOR(S)</b> William B. Alston, Richard E. Gluyas, and William J. Snyder				
<b>7. PERFORMING ORGANIZATION NAME(S) AND ADDRESS(ES)</b> NASA Lewis Research Center Cleveland, Ohio 44135-3191 and Propulsion Directorate U.S. Army Aviation Systems Command Cleveland, Ohio 44135-3191			<b>8. PERFORMING ORGANIZATION REPORT NUMBER</b>  E-6971	
<b>9. SPONSORING/MONITORING AGENCY NAMES(S) AND ADDRESS(ES)</b>  National Aeronautics and Space Administration Washington, D.C. 20546-0001 and U.S. Army Aviation Systems Command St. Louis, Mo. 63120-1798			<b>10. SPONSORING/MONITORING AGENCY REPORT NUMBER</b>  NASA TM-105629 AVSCOM TR-91-C-023	
<b>11. SUPPLEMENTARY NOTES</b> Prepared for the Fourth International Conference on Polyimides sponsored by the Society of Plastic Engineers, Ellenville, New York, October 30-November 1, 1991. William B. Alston, Propulsion Directorate, U.S. Army Aviation Systems Command, Richard E. Gluyas, NASA Lewis Research Center (deceased); William J. Snyder, Bucknell University, Dept. of Chemical Engineering, Lewisburg, Pennsylvania 17837. Responsible person, William B. Alston, (216) 433-3220.				
<b>12a. DISTRIBUTION/AVAILABILITY STATEMENT</b>  Unclassified - Unlimited Subject Category 27			<b>12b. DISTRIBUTION CODE</b>	
<b>13. ABSTRACT (Maximum 200 words)</b>  The effects of formulated molecular weight (FMW), extent of cure, and cumulative aging on the amount of cyclopentadiene (CPD) evolved from Polymerization of Monomeric Reactants (PMR) polyimides were investigated by pyrolysis-gas chromatography (PY-GC). The PMR polyimides are addition crosslinked resins formed from an aromatic diamine, a diester of an aromatic tetracarboxylic acid and a monoester of 5-norbornene-2, 3-dicarboxylic acid. The PY-GC results were related to the degree of crosslinking and to the thermo-oxidative stability (weight loss) of PMR polyimides. Thus, PY-GC was shown to be a valid technique for the characterization of PMR polyimide resins and composites via correlation of the CPD evolved versus the thermal history of the PMR sample.				
<b>14. SUBJECT TERMS</b> PMR; Polyimides; PMR-15; Pyrolysis-gas chromatography; Cyclopentadiene			<b>15. NUMBER OF PAGES</b> 22	
			<b>16. PRICE CODE</b> A03	
<b>17. SECURITY CLASSIFICATION OF REPORT</b> Unclassified	<b>18. SECURITY CLASSIFICATION OF THIS PAGE</b> Unclassified	<b>19. SECURITY CLASSIFICATION OF ABSTRACT</b> Unclassified	<b>20. LIMITATION OF ABSTRACT</b>	