

NASA Technical Memorandum 4333

Effect of Collector Configuration on Test Section Turbulence Levels in an Open-Jet Wind Tunnel

G. S. Manuel and John K. Molloy
*Langley Research Center
Hampton, Virginia*

P. Stephen Barna
Norfolk, Virginia



National Aeronautics and
Space Administration

Office of Management

Scientific and Technical
Information Program

1992

Summary

Flow quality studies in the Langley 14- by 22-Foot Subsonic Tunnel indicated periodic flow pulsations at discrete frequencies in the test section when the tunnel operated in an open-jet configuration. To alleviate this problem, experiments were conducted in a 1/24-scale model of the full-scale tunnel to evaluate the turbulence reduction potential of six collector configurations.

For each collector configuration, the turbulence level of the test section was recorded. The original bell-mouth collector configuration produced the least desirable turbulence characteristics, whereas a collector configuration with long straight walls and a slot between the trailing edge of the collector and the entrance to the diffuser proved to be the most effective in reducing the test section velocity fluctuations. The effect of the test section length on the turbulence level was also studied. The results of these tests showed that a decrease in jet length was accompanied by a decrease in the turbulence level.

As a result of these studies, the original bell-mouth collector of the 14- by 22-Foot Subsonic Tunnel was replaced with a collector with straight walls, and a slot was incorporated between the trailing edge of the collector and the entrance of the diffuser.

Introduction

In many open test section configurations, aerodynamic testing takes place without the constraints of walls, floor, and ceiling. The Langley 14- by 22-Foot Subsonic Tunnel is open on three sides and is constrained on the fourth side by the floor (refs. 1 and 2). This test section, as seen in figure 1, is capable of operating in both open and closed test section configurations. In the open test section configuration without the surface constraints, interactions of the unstable shear layer with the uniform open jet occur which create high levels of periodic oscillatory airflow. More specifically, the uniform free-stream open-jet length from the nozzle exit, which has organized vortex structure, expands downstream and induces air at the outer boundary of the core to flow with it. The mixing of ambient air and the unstable shear layer produces a loss of momentum and velocity uniformity. Consequently, this produces unsteady, pulsating flow along the open jet at distinct tunnel velocities. This turbulence carries throughout the entire wind-tunnel circuit, and the increased turbulence results in flow quality degradation. Since the open test section configuration is used for rotorcraft model and acoustical testing, the increased turbulence and unsteady airflow interfere with aerodynamic measurements.

Past efforts focused on unsteady flow along the jet in the open test section configuration. These studies established that the unsteady flow can be mitigated by altering the surface of the jet with tabs or jet exit vanes located at the exit of the contraction (ref. 3). These devices served to eliminate the oscillating flow by spreading and stabilizing the shear layer and by destroying the coherent vortex structure. The effects of the jet exit vanes on the flow pulsations in the 14- by 22-Foot Subsonic Tunnel were reported in references 4 and 5. Data from these experiments showed that the presence of jet exit vanes reduced flow pulsations. However, the vanes also produced an adverse side effect—reduction of the potential core of the open jet.

Use of a collector to eliminate or reduce the flow pulsations without the disadvantage of decreasing the size of the potential core was another method that was investigated. Several different collector configurations were evaluated in a 1/24-scale model of the Langley 14- by 22-Foot Subsonic Tunnel. The collector was mounted to the test section floor in front of the entrance to the first diffuser. Research by Jacobs (ref. 6) indicated that a properly shaped collector placed at the diffuser entrance would reduce free-stream turbulence levels. The selection of different collector designs evaluated in the model tunnel was based on the German-Dutch Wind Tunnel (DNW) collector. This collector is comprised of straight walls with an air slot between the trailing edge of the collector and the first diffuser (ref. 7). The collector has two functions: it facilitates smooth airflow entry into the diffuser and also sets the rate of airflow that enters the diffuser to maintain constant recirculating flow around the tunnel circuit.

Symbols

A_{ca}	collector entrance area, ft ²
A_c	collector exit area, ft ²
L_{cw}	length of collector wall, in.
L_{TS}	open test section length, from nozzle exit to collector, in.
q_t	tunnel dynamic pressure, psf
R	radius of curvature, in.
rms	root mean square
U	mean free-stream air velocity, ft/sec
W_c	width of nozzle contraction at jet exit, in.
W_d	width of first diffuser entrance, in.

X_p	distance of hot-wire probe from contraction jet exit, in.
$\tilde{\mu}$	longitudinal velocity fluctuations, ft/sec (rms)
α_s	sidewall angle of collector sides, deg
α_t	angle between deflector and ceiling, deg

Test Apparatus and Collector Configurations

A 1/24-scale model of the Langley 14- by 22-Foot Subsonic Tunnel in the open test section configuration was used to evaluate six different collector configurations. A sketch of the model test chamber of the tunnel in the open test section configuration is shown in figure 2(a) and a photograph of the complete tunnel circuit is shown in figure 2(b). Top- and side-view sketches of each collector configuration evaluated are shown in figure 3.

Most collector configurations had three straight sides—two sidewalls and a top side. Some configurations had sides of constant thickness, whereas others were formed with a thick NACA airfoil profile. The capture area was varied by manipulating the sidewall angle. Capture area A_{ca}/A_e is the cross-section area at the collector entrance divided by the area at the collector exit. The addition of a deflector, which was an extension from the collector top side to the test section ceiling in the raised position, was also investigated. All configurations were evaluated with an air slot between the trailing edge of the collector and the entrance of the first diffuser.

Fluctuations in velocity were measured with a one-component constant-temperature, hot-wire anemometer. The hot-wire probe used a 0.00015-inch-diameter platinum-coated, tungsten wire. The orientation and calibration of the probe followed the same procedure described in reference 4. The hot-wire probe was located on the centerline of the test section, 11 in. from the nozzle jet exit ($X_p/W_c = 1.02$) unless otherwise specified.

Test Methods

For each collector configuration, the dynamic pressure in the model tunnel was incrementally increased from 2 to 40 psf. Free-stream turbulence was measured with the hot-wire probe, which provided rms velocity fluctuations $\tilde{\mu}$, and the nondimensional quantity $\tilde{\mu}/U$ was calculated. Graphs of $\tilde{\mu}/U$ as a function of the free-stream dynamic pressure q_t were used to measure the effectiveness of each collector configuration.

Test Results

Configuration 1

Configuration 1 models a bell-mouth collector. This configuration, without a slot, represents the original bell-mouth collector of the Langley 14- by 22-Foot Subsonic Tunnel and is referred to as the "baseline configuration." Figure 4 shows the measured turbulence levels for configuration 1 as a function of tunnel dynamic pressure and probe location (X_p/W_c). The variation of tunnel dynamic pressure affects the level of turbulence intensity, with the largest turbulence intensity occurring at the lower dynamic pressures ($q_t = 2$ to 10 psf) for all probe locations.

To study the effects of slot length, the probe was fixed 11 in. ($X_p/W_c = 1.02$) from the nozzle jet exit. A sketch of the slotted collector configuration is shown in figure 3(a). Figure 5(a) shows high turbulence intensities for the unslotted baseline configuration at tunnel dynamic pressures of 4, 8, 12, and 22 psf. The turbulence levels are reduced with a 1-in-long slot between the collector exit and the diffuser entrance. The use of a slotted configuration reduced the turbulent peaks by more than 50 percent, except for the first peak which occurred at $q_t = 4$ psf.

The application of a deflector, which is an extension from the leading edge of the top side of the collector to the raised test section ceiling, was evaluated to determine the effects on the test section turbulence levels. A sketch of this collector configuration is also presented in figure 3(a). A 3-in. slot plus a deflector eliminated the turbulent peaks at $q_t = 6$ psf and 12 psf and significantly reduced the high turbulence intensity at $q_t = 2$ psf. (See fig. 5(b).)

Configuration 2

Unlike the baseline configuration, collector configuration 2 incorporated straight sidewalls ($L_{cw}/W_d = 0.74$) with a small rounded lip at the entrance to the collector (fig. 3(b)). In comparison with the baseline configuration, configuration 2 (without slot and deflector) reduced most high turbulent intensities except for the peak at $q_t = 2$ psf. (See fig. 6.) The addition of a 1-in. slot further reduced the high turbulent intensities at $q_t = 2$ psf and $q_t = 18$ psf. The combination of a 1-in. slot and a deflector (fig. 3(b)) resulted in significant turbulence reduction in the test section. This configuration produced a test section turbulence level of 0.4 percent without the presence of high turbulent intensities.

The effect on free-stream turbulence levels of varying slot length and the capture area in configuration 2 was also investigated. Capture area, the ratio

of the cross-section area at the collector entrance divided by the area at the collector exit, A_{ca}/A_e , was varied by manipulating the sidewall angle only. Figure 3(b) shows a sketch of configuration 2 with a capture area A_{ca}/A_e of 1.85. A larger and a smaller capture area ($A_{ca}/A_e = 2.19$ and 1.62) were also used, and the results are presented in figure 7. The larger capture area produced lower turbulence levels, particularly with a 1-in-long slot.

Configuration 3

Collector configuration 3 had shorter walls ($L_{cw}/W_d = 0.69$) than configuration 2 and the top of the collector extended to the ceiling of the test section. Two capture areas were investigated with this configuration. Sidewall angles of 7° and 26° produced capture areas of 2.10 and 2.85, respectively. As shown in figure 8, high turbulent intensities were not present for the larger capture area ($A_{ca}/A_e = 2.85$). With the smaller capture area ($A_{ca}/A_e = 2.01$), the test section turbulence level was slightly higher than with the larger capture area.

Configuration 4

Collector configuration 4 had shorter walls ($L_{cw}/W_d = 0.37$) than configuration 3. Several deflector positions were investigated with this configuration; each extended to the ceiling with incidence angles from 25° to 90° . Results in figure 9(a) show that the deflector positioned at 25° produced the lowest turbulent peaks for configuration 4.

To study the effect of sidewall length, configuration 4 was fitted with longer sidewalls by mounting sidewall extensions to the existing 4.5-in. sidewalls. The 1-in. and 2-in. sidewall extensions ($L_{cw}/W_d = 0.45$ and 0.54, respectively) were evaluated with the deflector angle fixed at 45° . Results in figure 9(b) show a significant decrease in the turbulent peaks with the 2-in. extension.

Another variable that was explored to determine its effect on test section turbulence level was extensions to the nozzle at the jet exit. The nozzle exit was varied by the addition of straight sidewall extensions on all three sides of the nozzle. With the addition of the nozzle extensions and the collector position fixed, the test section length, L_{TS} , was subsequently reduced. The nozzle extensions were investigated with collector configuration 4 (without extensions) using the 45° deflector. Figure 10(a) shows the effects of 2-in. and 3-in. nozzle extensions, $L_{TS}/W_c = 2.43$ and 2.34, respectively. The turbulent fluctuations decreased, but high peaks still persisted at tunnel dynamic pressure of $q_t = 3$ psf.

The final variation studied with collector configuration 4 was the effect of measurement location. Figure 10(b) shows the effects of the measurement location and nozzle extensions. The data are presented for no nozzle extension, normal measurement location; no nozzle extension, hot-wire measurement location moved forward 3 in. toward the jet exit; and 3-in. nozzle extension, measurement location moved back 3 in. from the normal measurement location. The turbulent peak at $q_t = 3$ psf is not eliminated by moving the measurement location forward 3 in. ($L_{TS}/W_c = 2.61$, $X_p/W_c = 0.73$) or by adding a 3-in. nozzle extension ($L_{TS}/W_c = 2.34$, $X_p/W_c = 0.73$).

Configuration 5

In collector configuration 5, the straight sidewall profile was replaced with sidewalls that incorporated curvature with an airfoil profile. Configuration 5 used a sidewall thickness distribution of an NACA 664-021 airfoil with a chord of 5 in., $L_{cw}/W_d = 0.41$. Experiments were performed with sidewall incidence angles α_s , measured with respect to airfoil chord line, of 10° and 29.3° and collector top angles α_t of 12° and 20.5° , respectively. Test section turbulence levels for these two configurations are shown in figure 11. A large turbulent peak appeared at a tunnel dynamic pressure of $q_t = 3$ psf, regardless of the incidence and sidewall angles.

Configuration 6

Collector configuration 6 was similar to configuration 5, except the sidewall airfoil chord was increased to 7 in., $L_{cw}/W_d = 0.58$. For $\alpha_s = 4^\circ$ and 14° , low turbulence levels resulted; except at $q_t = 3$, the level rose to 1 percent (fig. 12). When compared with results for the baseline bell-mouth configuration, the turbulence levels for configuration 6 were significantly reduced.

Summary of Results

Table 1 provides a summary of the six different collector configurations and the parameters that were varied. The geometry of the collector was the dominant variable for reducing test section turbulence. The original baseline bell mouth was the least effective design, whereas collectors with straight, long walls produced the best results. Overall, collectors which had the longer sidewalls, configurations 2 and 3, produced lower test section turbulence than the configurations with shorter sidewalls, configurations 4, 5, and 6. However, configuration 4 with deflectors lowered these high turbulence levels, especially at the lower tunnel dynamic pressures ($q_t = 3$). The use of streamlined walls (NACA 664-021 airfoil

cross section) did not improve the test section turbulence levels.

Another important influence on turbulence levels was the slot located between the trailing edge of the collector and the diffuser entrance. Evaluation of collector configuration 1 without a slot (baseline configuration) and with slot widths of 1, 2, and 3 in. demonstrated that a slot can greatly reduce turbulence levels, particularly at tunnel dynamic pressures above $q_t = 8$.

The effect of the location of the turbulence measurement position was also investigated with collector configurations 1 and 4. Varying measurement location showed that turbulence levels increased with increasing distance from the nozzle jet exit.

Conclusions

Several collector configurations tested in the open test section configuration of the 1/24-scale model of the Langley 14- by 22-Foot Subsonic Tunnel resulted in collector designs which were improvements over the original bell-mouth collector. The test results lead to the following conclusions:

1. Peak turbulence levels of 2.6 percent were experienced with the original bell-mouth collector without a slot.
2. Collectors that utilized a slot between the trailing edge of the collector and the first diffuser entrance and that incorporated a straight wall profile reduced turbulence levels.
3. Deflectors that extended the top wall of the collector to the ceiling tended to reduce the turbulence levels.
4. Turbulence levels are a function of measurement position relative to the nozzle jet exit. Turbulence levels increased with increasing distance from the nozzle jet exit.

As a result of these studies, the original bell-mouth collector of the Langley 14- by 22-Foot Subsonic Tunnel was replaced with a straight wall collector, and a slot was incorporated between the trailing edge of the collector and the first diffuser entrance.

NASA Langley Research Center
Hampton, VA 23665-5225
April 1, 1992

References

1. Applin, Zachary T.: *Flow Improvements in the Circuit of the Langley 4- by 7-Meter Tunnel*. NASA TM-85662, 1983.
2. Gentry, Garl L., Jr.; Quinto, P. Frank; Gatlin, Gregory M.; and Applin, Zachary T.: *The Langley 14- by 22-Foot Subsonic Tunnel: Description, Flow Characteristics, and Guide for Users*. NASA TP-3008, 1990.
3. Seiferth, R.: Pre-Calculation and Removal of Oscillations in Free-Jet Wind Tunnels. *D₁ Model Test Technique—I. Test Installations*, R. Seiferth, ed., Rep. and Transl. No. 947, British M.A.P. Völkenrode, Aug. 1, 1947, pp. 65-86.
4. Sellers, William L., III; Applin, Zachary T.; Molloy, John K.; and Gentry, Garl L., Jr.: *Effect of Jet Exit Vanes on Flow Pulsations in an Open-Jet Wind Tunnel*. NASA TM-86299, 1985.
5. Hoad, Danny R.; and Martin, Ruth M.: *Background Noise Measurements From Jet Exit Vanes Designed To Reduce Flow Pulsations in an Open-Jet Wind Tunnel*. NASA TM-86383, AVSCOM TM 85-B-1, 1985.
6. Jacobs, Eastman N.: *Investigation of Air Flow in Open-Throat Wind Tunnels*. NACA Rep. 322, 1929.
7. *Compilation of Calibration Data of the German-Dutch Wind Tunnel*. MP-82.01, DNW, Mar. 13, 1982.

Table 1. Summary of Collector Configurations Evaluated

[N/A means not applicable; a check mark means that variable was present, and a blank means it was not]

Configuration	Top angle, deg	Side angle, deg	Sidewall		Capture area	Slot, in.	Deflector	Nozzle extension	Measurement location, X_p/W_c
			Shape	Length, in.					
1	N/A	N/A	Bell mouth	5R	2.72	1			Varied
1	N/A	N/A	Bell mouth	5R	2.72	1, 2, 3			1.02
1	N/A	N/A	Bell mouth	5R	2.72	3	✓		1.02
2	10	15	Straight	9	1.85	None, 1	✓		1.02
2	10	15	Straight	9	2.19, 1.85, and 1.62	None, 1			1.02
3	32	7 and 26	Straight	8.3	2.01 and 2.85	1			1.02
4	20	15	Straight	4.5	N/A	1	✓		1.02
4	20	15	Straight	4.5, 5.5, and 6.5	N/A	1	✓		1.02
4	20	15	Straight	4.5	N/A	1	✓		1.02
5	12 and 20.5	10 and 29.3	NACA 664-021	5	1.31 and 1.74	1		✓	1.02 and 0.73
6	12 and 12	4.14	NACA 664-021	7	1.40 and 1.65	1			1.02

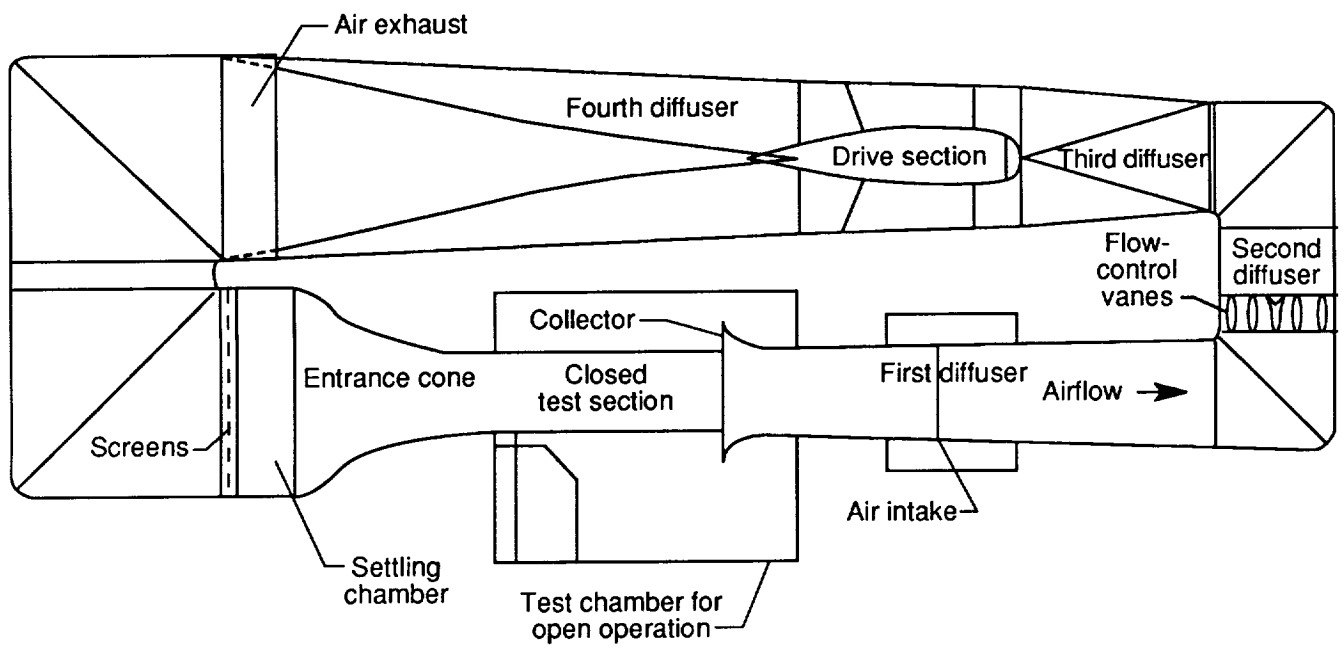
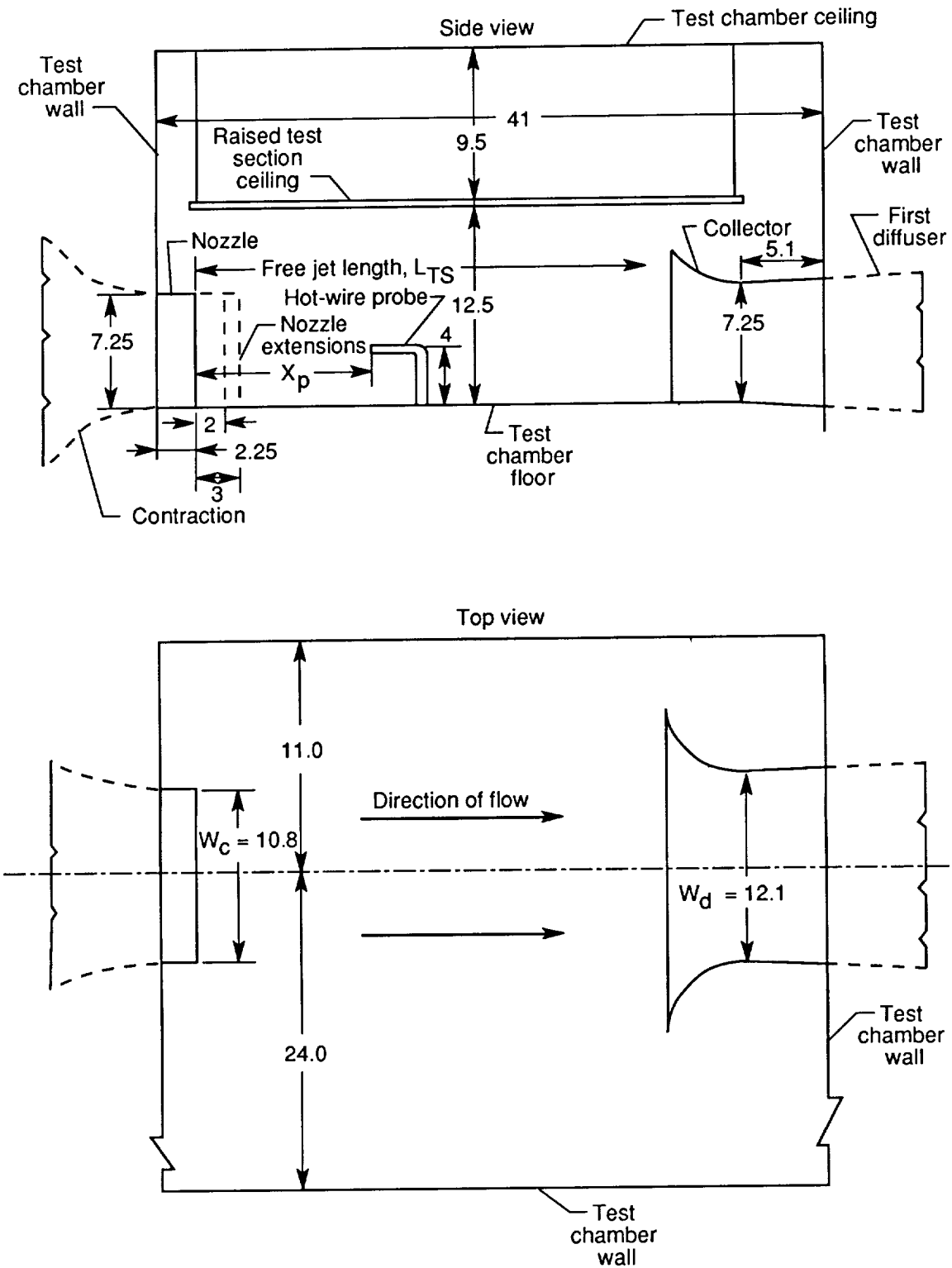

Figure 1. Plan view of original Langley 14- by 22-Foot Subsonic Tunnel configuration.



(a) Open test section configuration of model tunnel. Dimensions are in inches.

Figure 2. A 1/24-scale model of 14- by 22-Foot Subsonic Tunnel.

ORIGINAL PAGE
BLACK AND WHITE PHOTOGRAPH

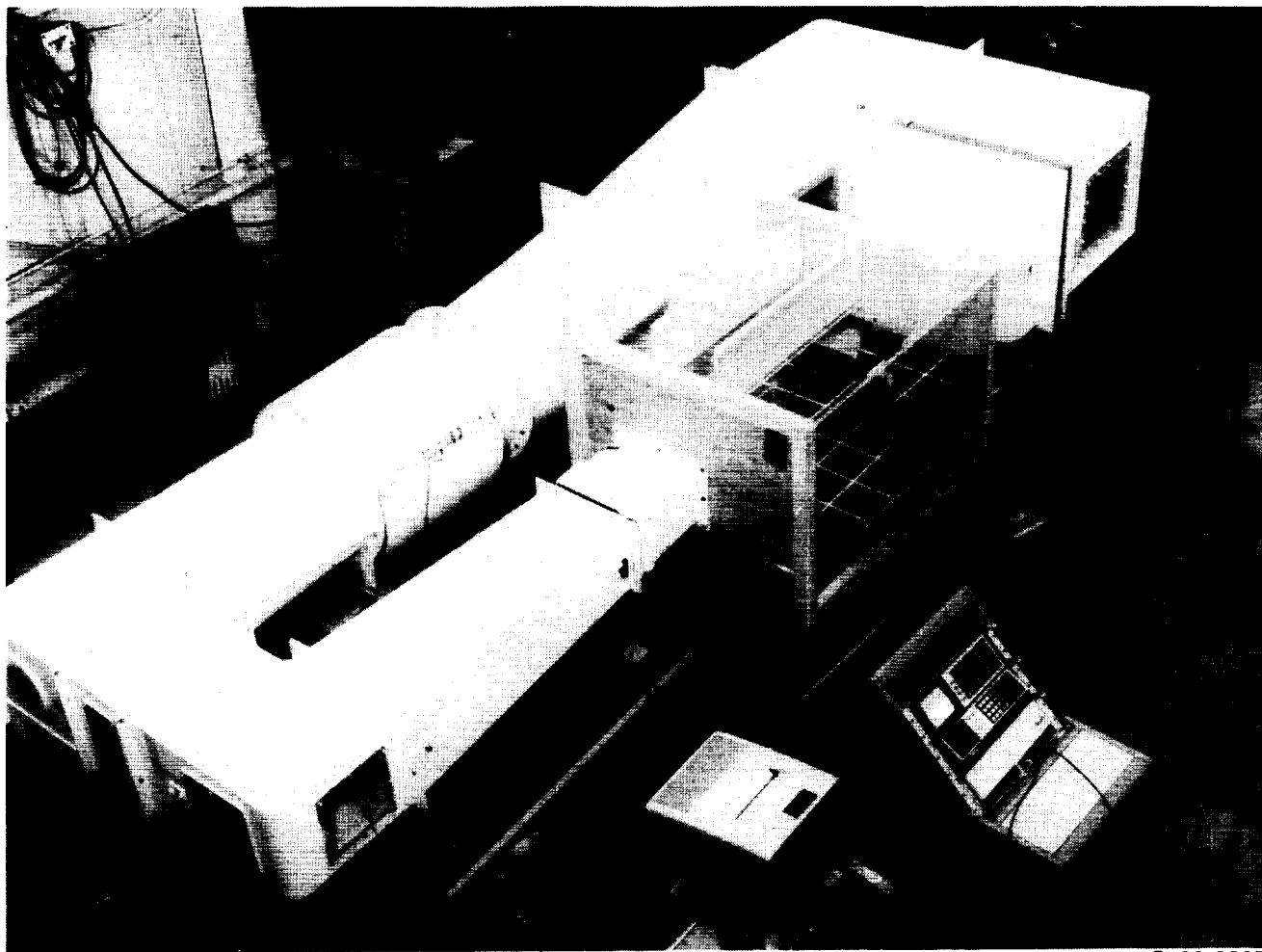

L-82-2397

(b) Model tunnel circuit with open test section.

Figure 2. Concluded.

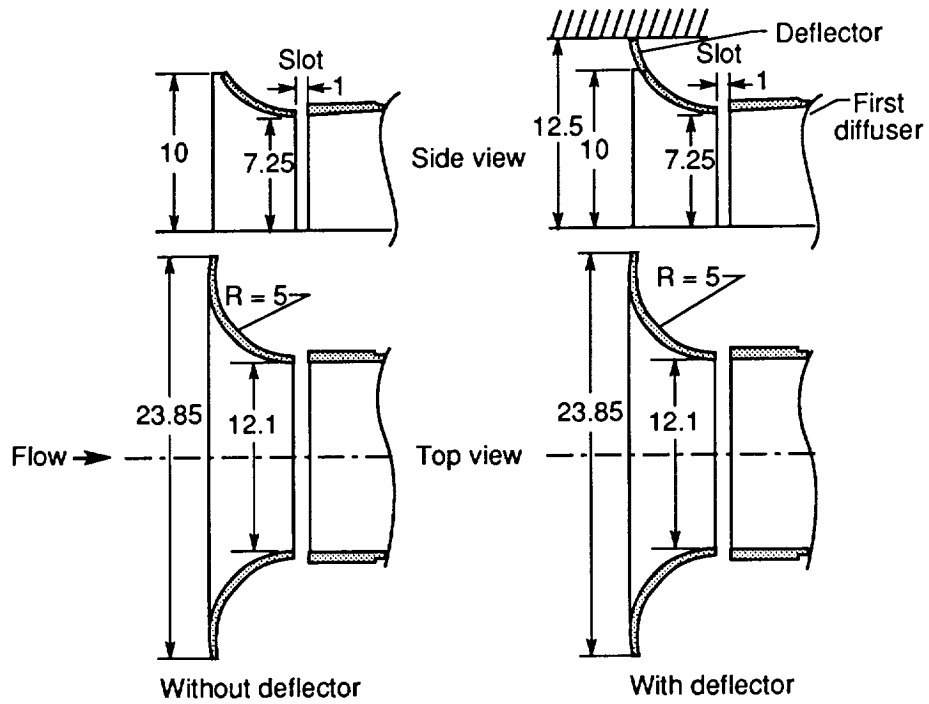

(a) Configuration 1.

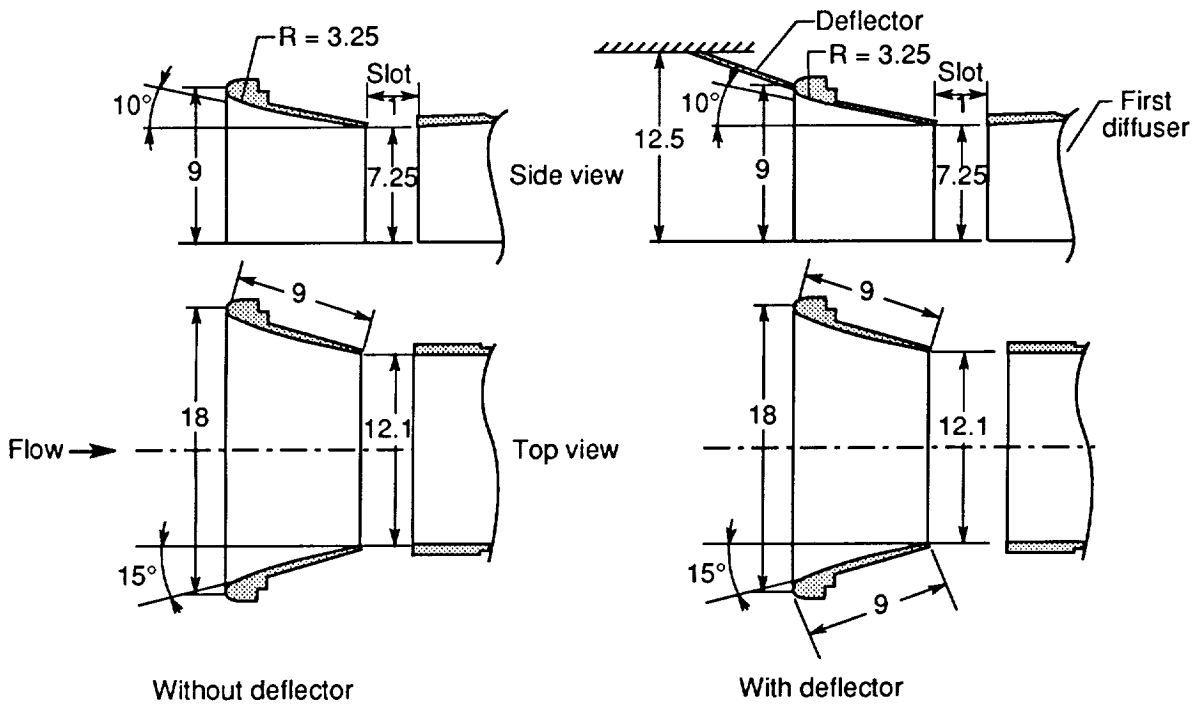

(b) Configuration 2.

Figure 3. Collector configurations evaluated. Dimensions are in inches.

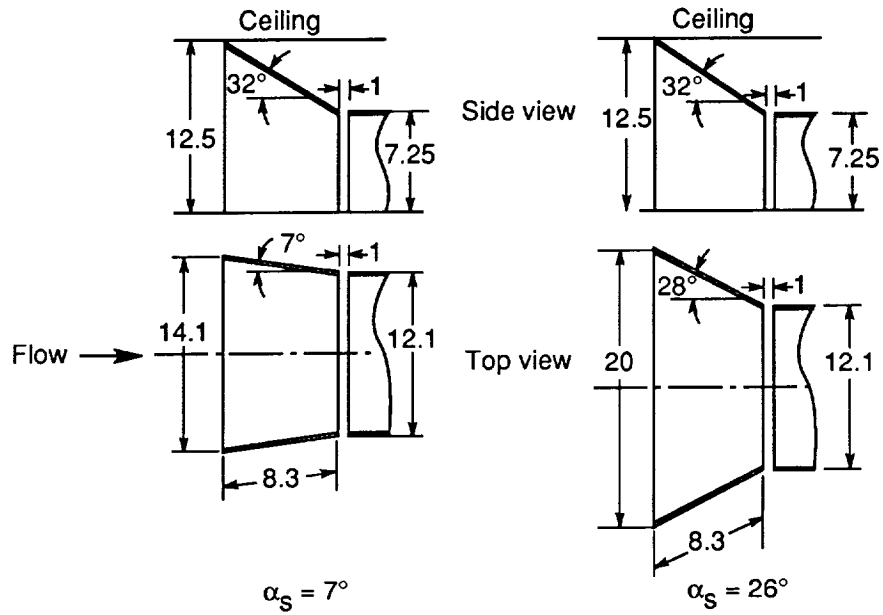

(c) Configuration 3.

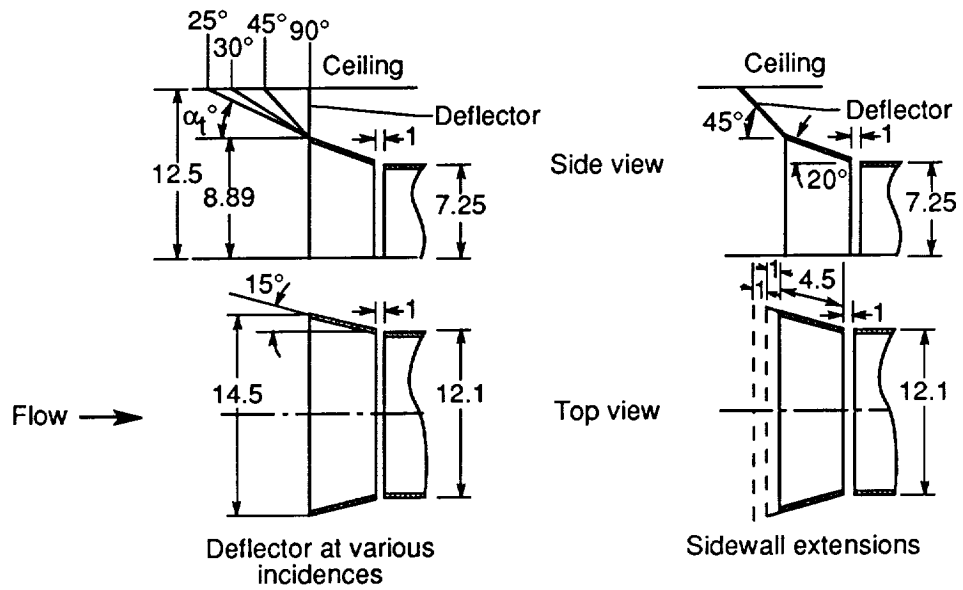

(d) Configuration 4.

Figure 3. Continued.

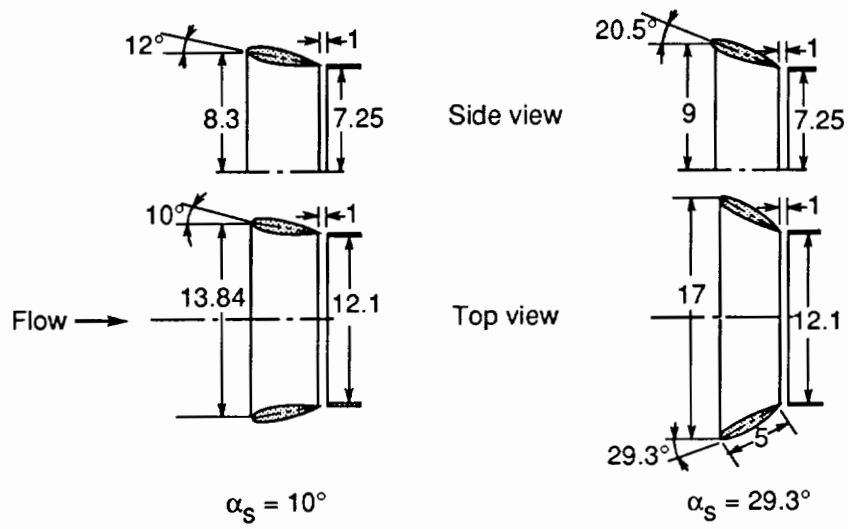

(e) Configuration 5.

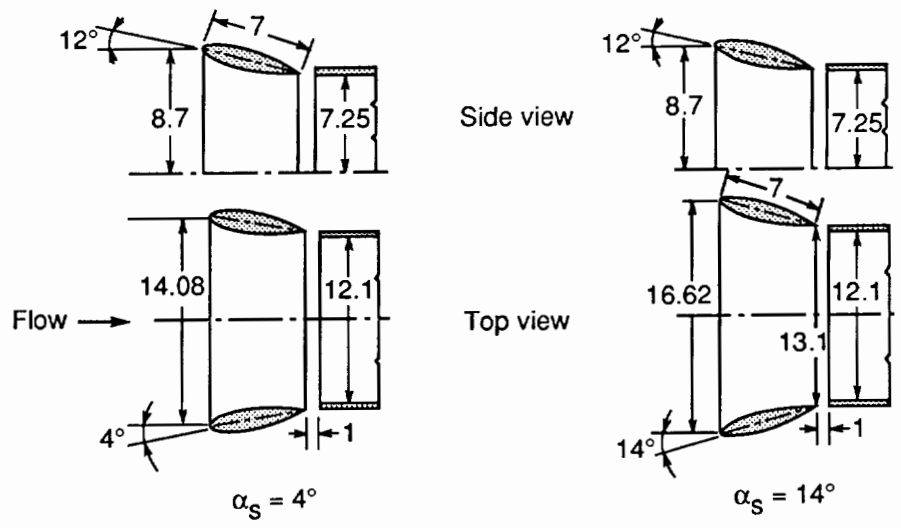

(f) Configuration 6.

Figure 3. Concluded.

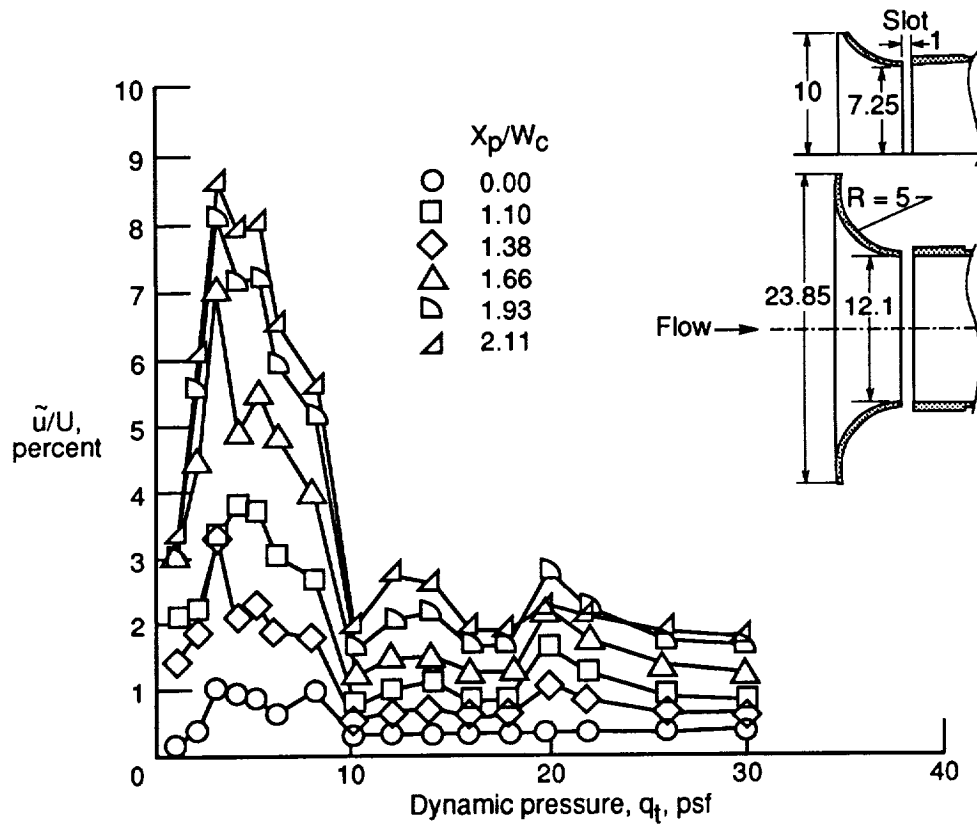
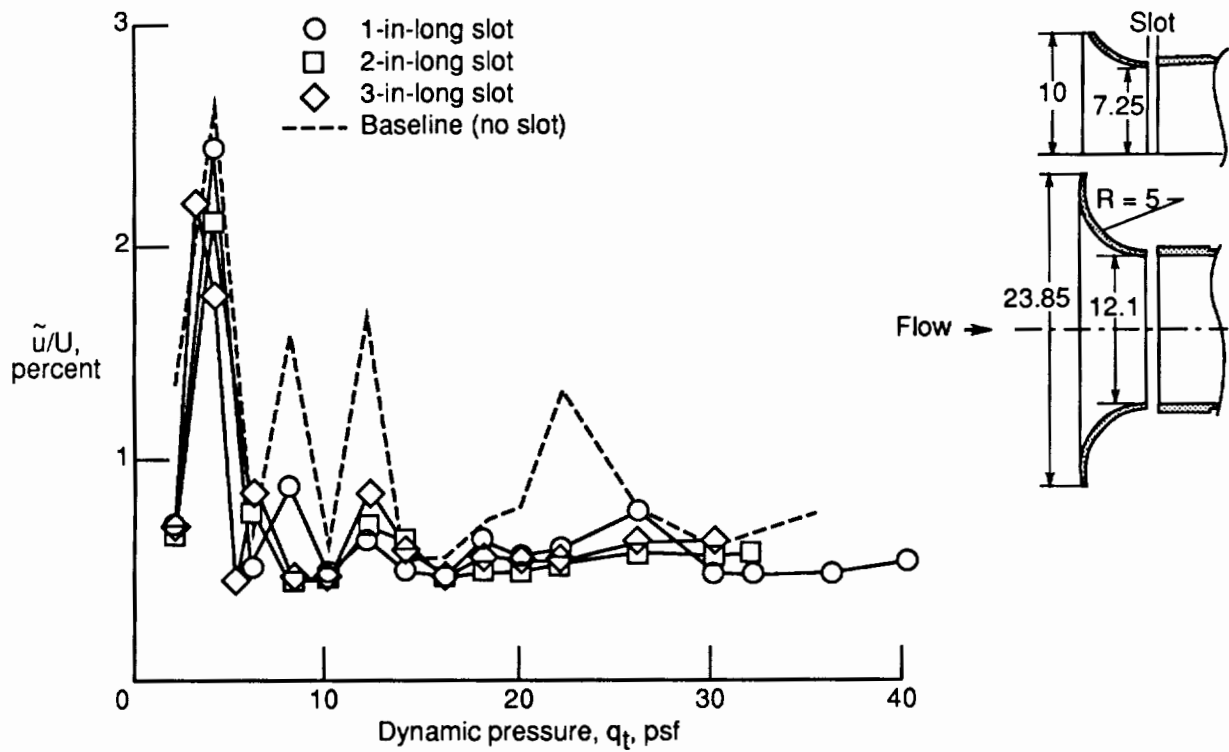
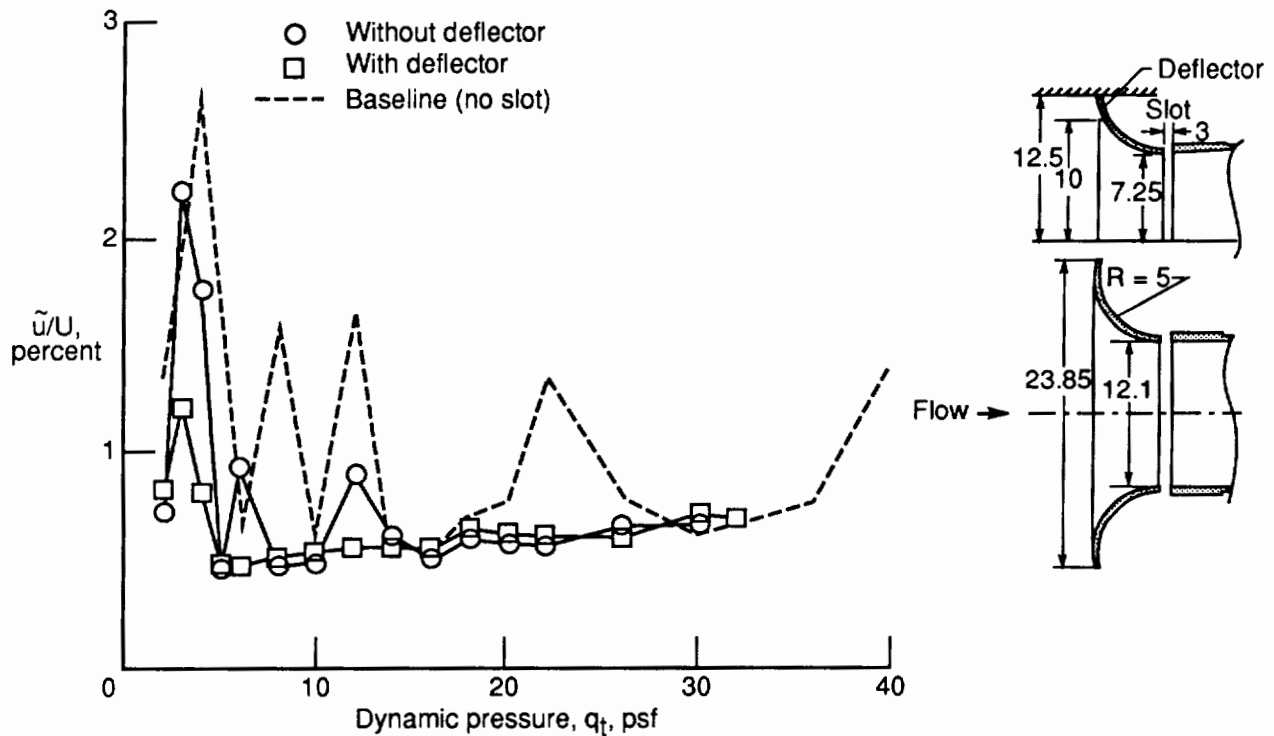

Figure 4. Longitudinal variation of turbulence intensity for configuration 1.



(a) Various slot sizes.



(b) 3-in. slot.

Figure 5. Effect of slot size and deflector on test section turbulence for configuration 1.

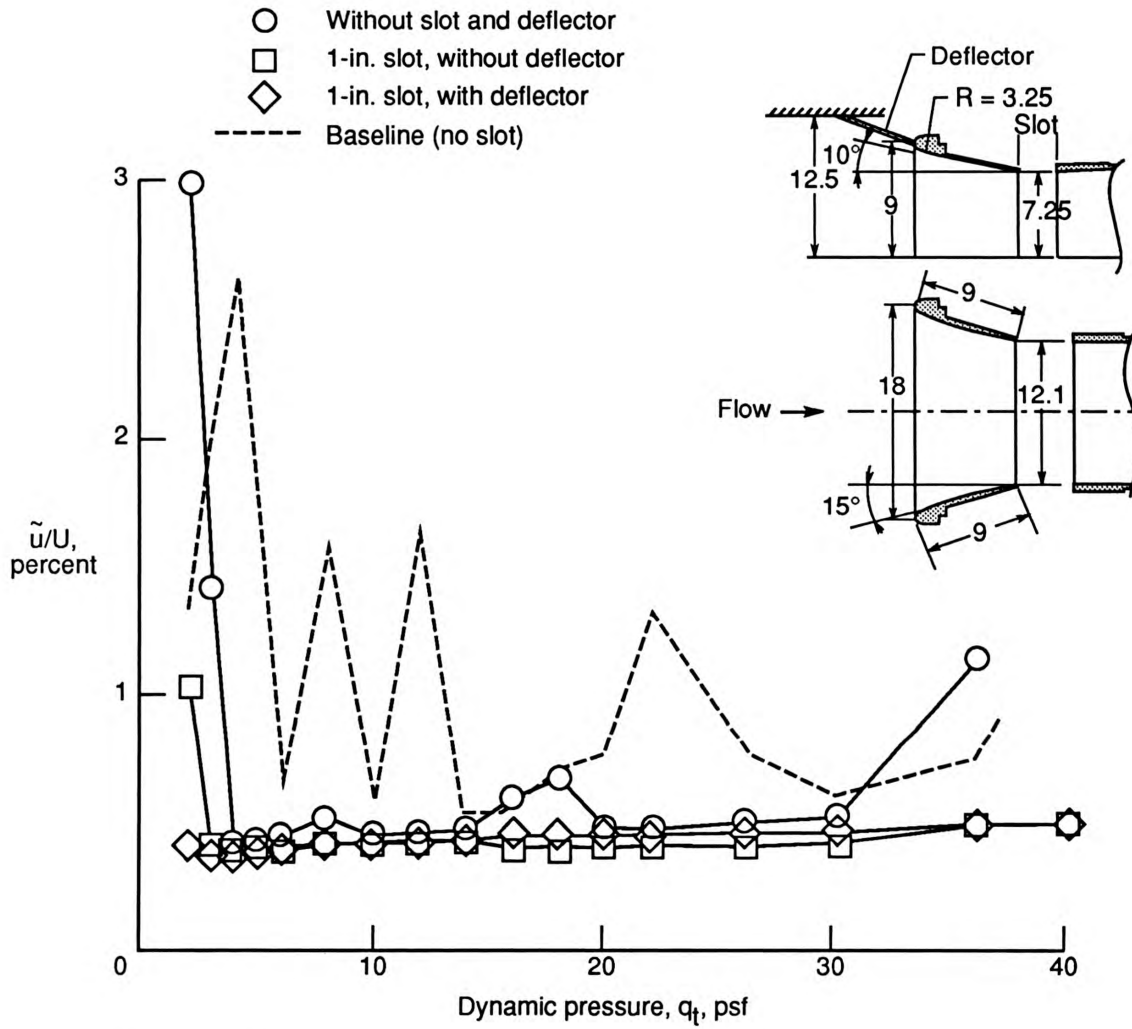
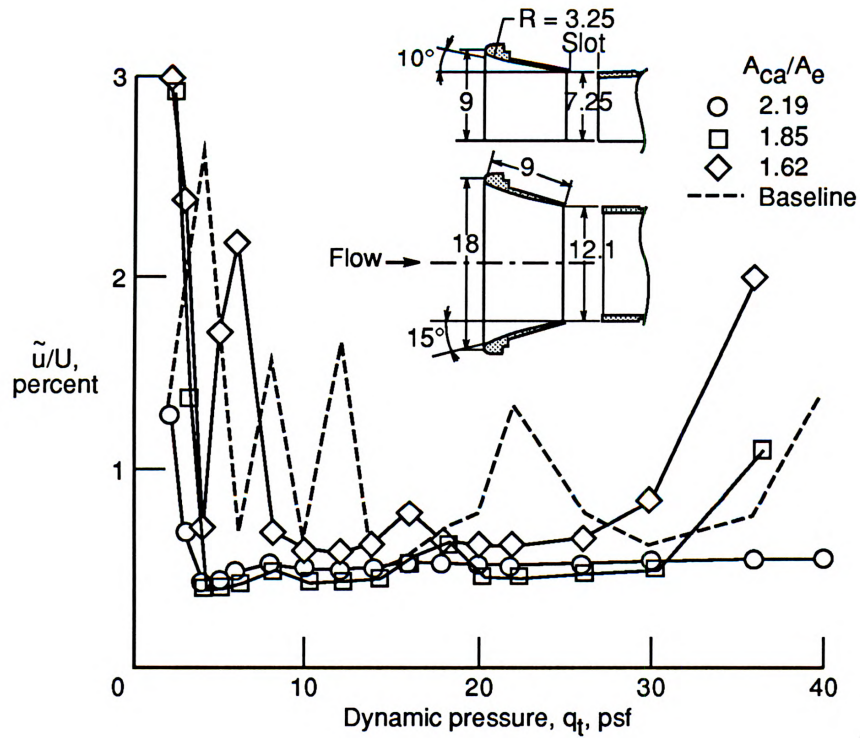
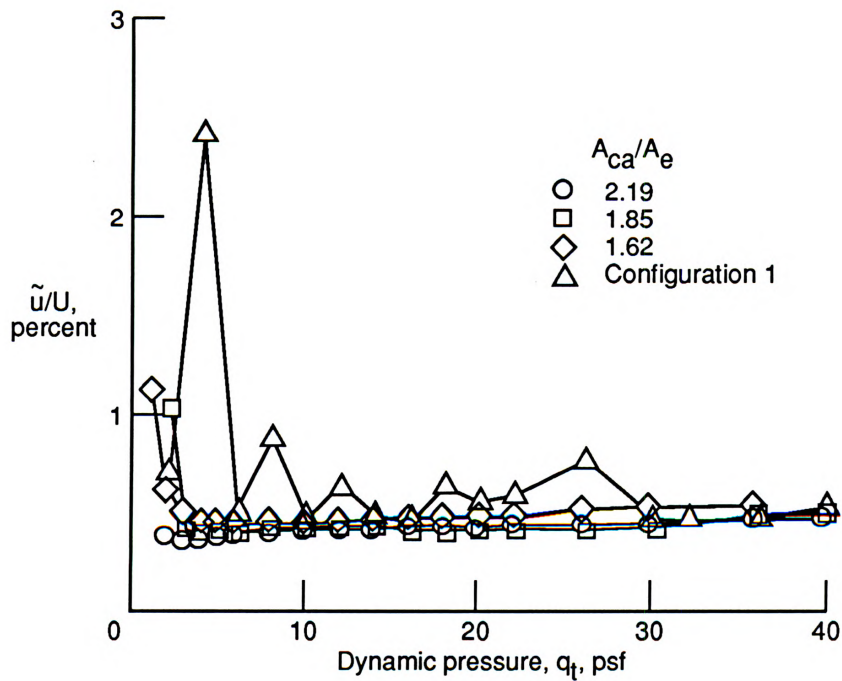

Figure 6. Effect of deflector and slot on test section turbulence for configuration 2.



(a) No slot.



(b) 1-in. slot.

Figure 7. Effect on test section turbulence from varying capture area for configuration 2.

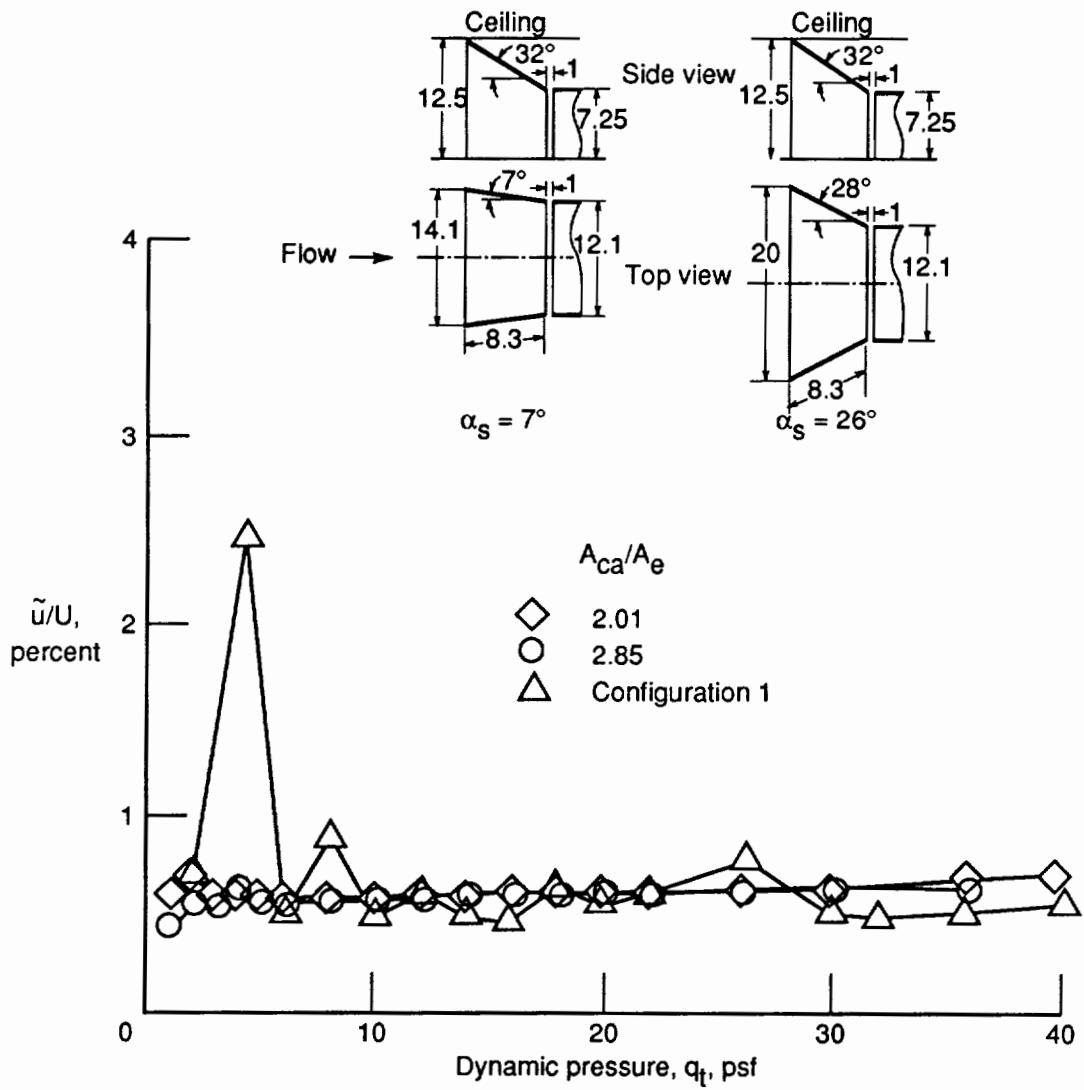
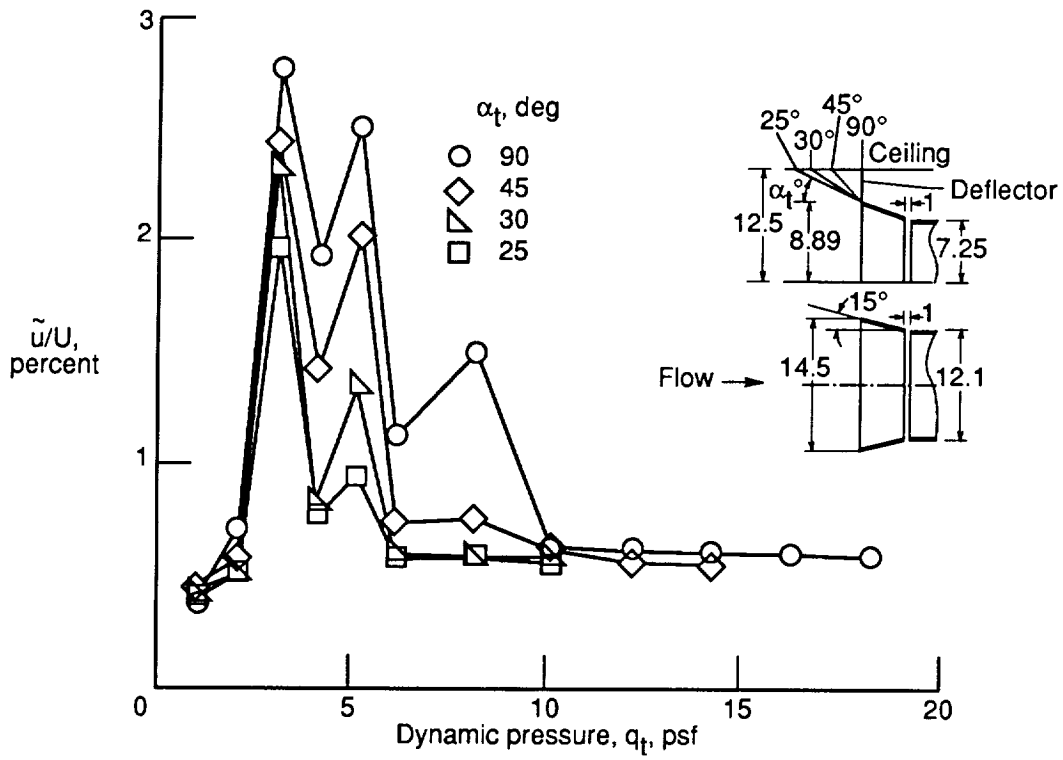
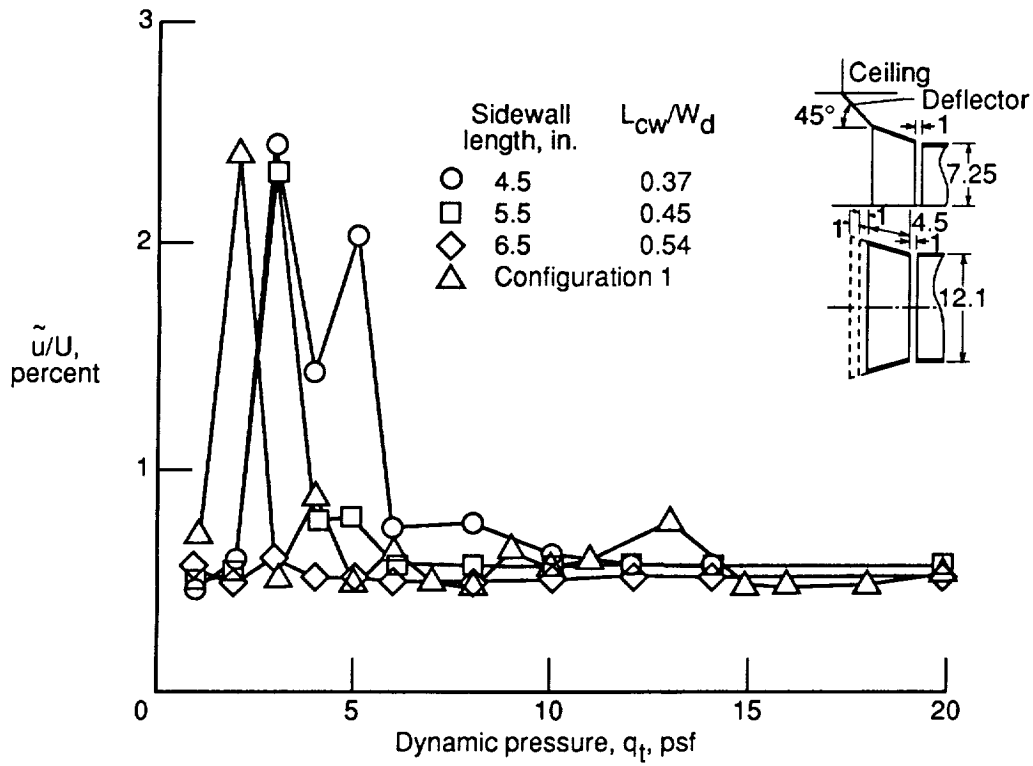

Figure 8. Effect on test section turbulence of varying capture area for configuration 3.



(a) Different deflector positions.



(b) Different sidewall lengths.

Figure 9. Effect on test section turbulence of different deflector positions and sidewall lengths for configuration 4.

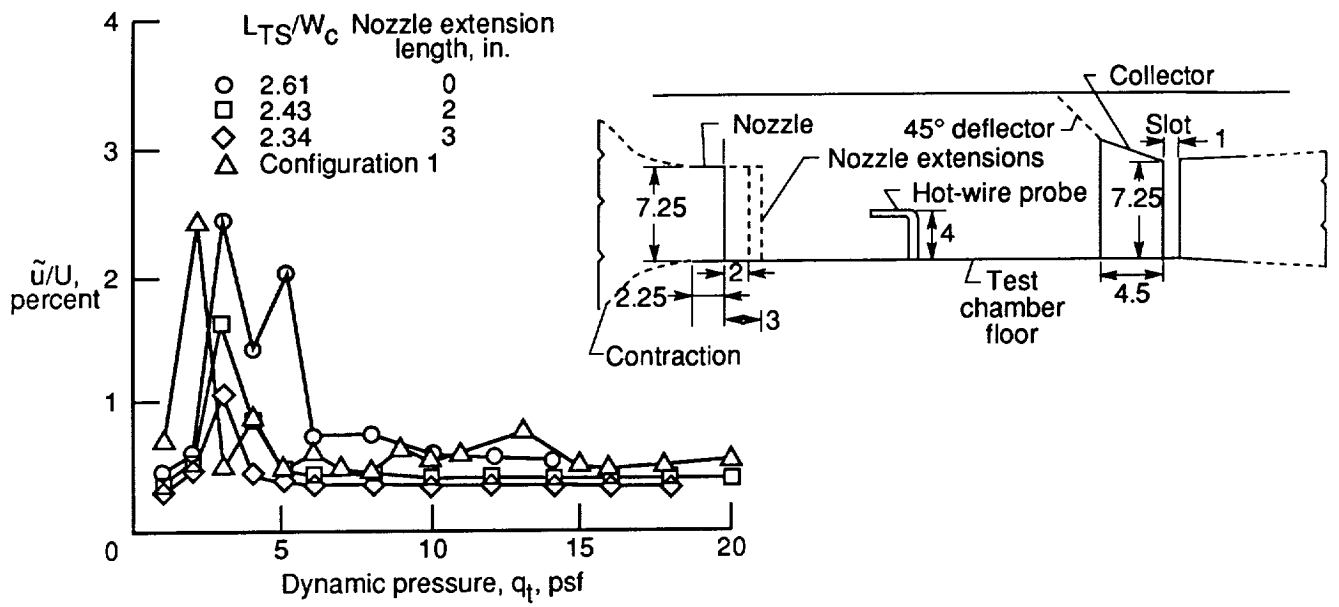

(a) Nozzle extensions.

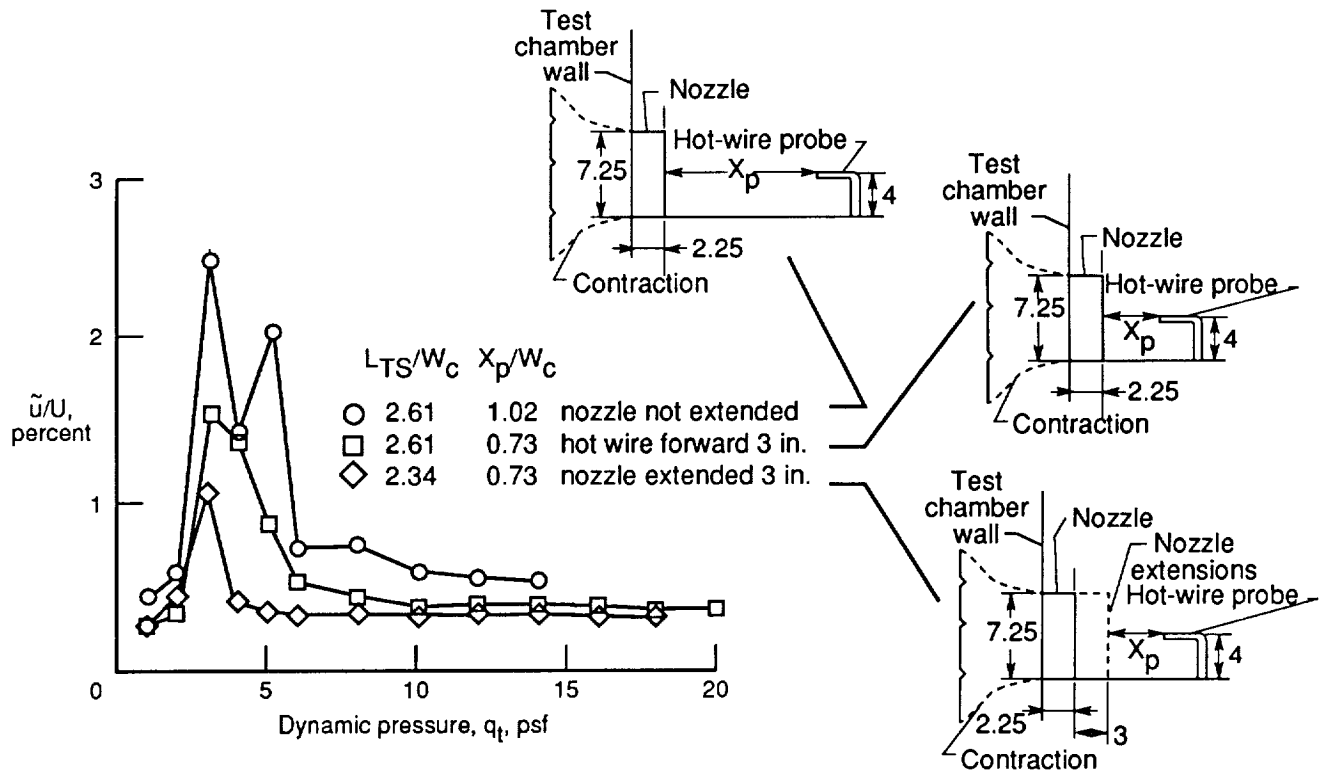

(b) Nozzle extensions and hot-wire probe locations.

Figure 10. Effect of contraction nozzle extensions and hot-wire probe locations on test section turbulence for configuration 4.

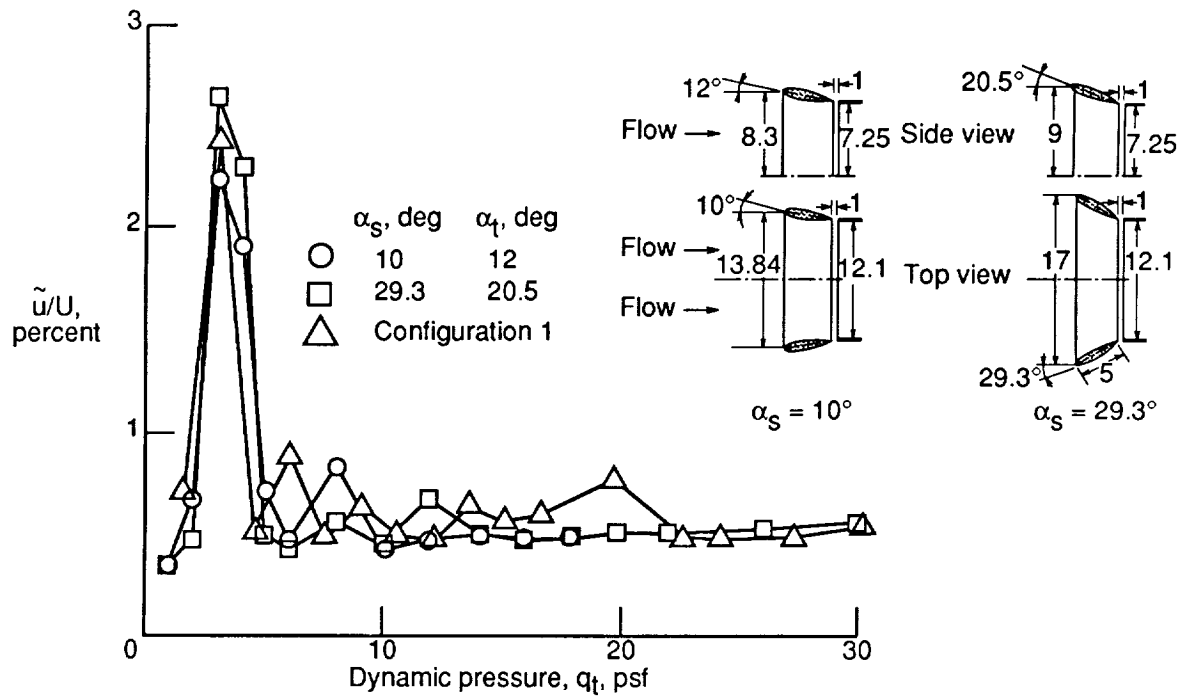

Figure 11. Effect on test section turbulence from varying 5-in. chord sidewall and top wall incidence angles for configuration 5.

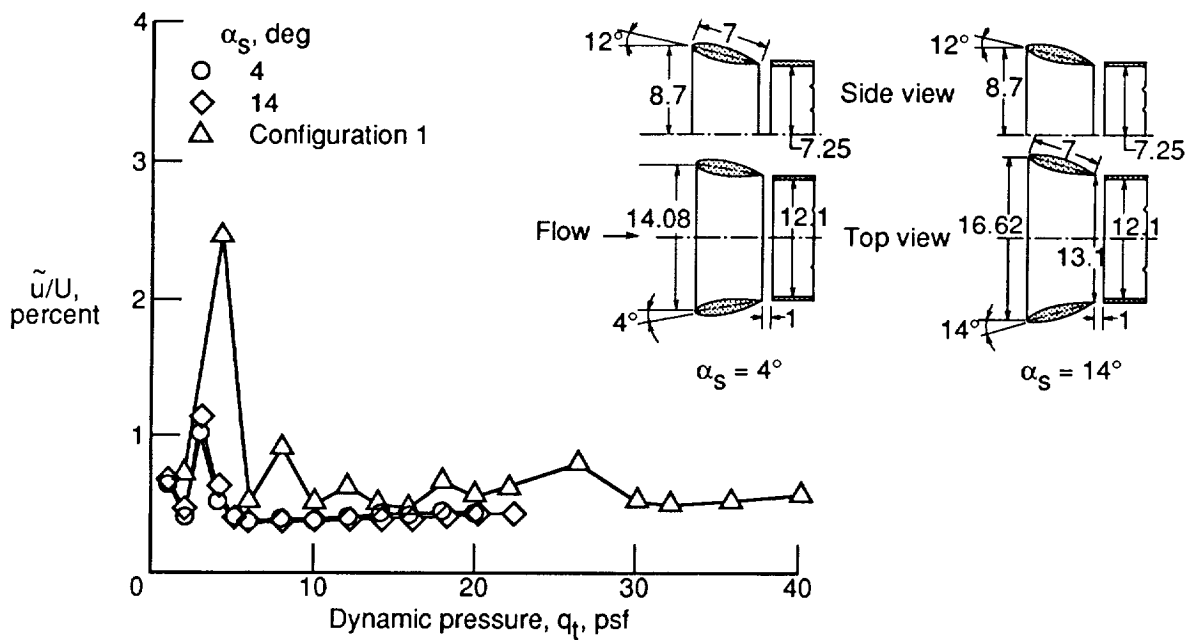

Figure 12. Effect on test section turbulence from varying 7-in. chord sidewall angles for configuration 6.



REPORT DOCUMENTATION PAGE			Form Approved OMB No. 0704-0188	
Public reporting burden for this collection of information is estimated to average 1 hour per response, including the time for reviewing instructions, searching existing data sources, gathering and maintaining the data needed, and completing and reviewing the collection of information. Send comments regarding this burden estimate or any other aspect of this collection of information, including suggestions for reducing this burden, to Washington Headquarters Services, Directorate for Information Operations and Reports, 1215 Jefferson Davis Highway, Suite 1204, Arlington, VA 22202-4302, and to the Office of Management and Budget, Paperwork Reduction Project (0704-0188), Washington, DC 20503.				
1. AGENCY USE ONLY (Leave blank)	2. REPORT DATE July 1992	3. REPORT TYPE AND DATES COVERED Technical Memorandum		
4. TITLE AND SUBTITLE Effect of Collector Configuration on Test-Section Turbulence Levels in an Open-Jet Wind Tunnel			5. FUNDING NUMBERS WU 505-61-41-02	
6. AUTHOR(S) G. S. Manuel, John K. Molloy, and P. S. Barna				
7. PERFORMING ORGANIZATION NAME(S) AND ADDRESS(ES) NASA Langley Research Center Hampton, VA 23665-5225			8. PERFORMING ORGANIZATION REPORT NUMBER L-16838	
9. SPONSORING/MONITORING AGENCY NAME(S) AND ADDRESS(ES) National Aeronautics and Space Administration Washington, DC 20546-0001			10. SPONSORING/MONITORING AGENCY REPORT NUMBER NASA TM-4333	
11. SUPPLEMENTARY NOTES Manuel and Molloy: Langley Research Center, Hampton, VA; Barna: Norfolk, VA.				
12a. DISTRIBUTION/AVAILABILITY STATEMENT Unclassified-Unlimited Subject Category 09			12b. DISTRIBUTION CODE	
13. ABSTRACT (Maximum 200 words) Flow quality studies in the Langley 14- by 22-Foot Subsonic Tunnel indicated periodic flow pulsations at discrete frequencies in the test section when the tunnel operated in an open-jet configuration. To alleviate this problem, experiments were conducted in a 1/24-scale model of the full-scale tunnel to evaluate the turbulence reduction potential of six collector configurations. As a result of these studies, the original bell-mouth collector of the 14- by 22-Foot Subsonic Tunnel was replaced with a collector with straight walls, and a slot was incorporated between the trailing edge of the collector and the entrance of the diffuser.				
14. SUBJECT TERMS Open-jet configuration; Airflow disturbance; Collector configuration; Turbulence levels.			15. NUMBER OF PAGES 20	
			16. PRICE CODE A03	
17. SECURITY CLASSIFICATION OF REPORT Unclassified	18. SECURITY CLASSIFICATION OF THIS PAGE Unclassified	19. SECURITY CLASSIFICATION OF ABSTRACT	20. LIMITATION OF ABSTRACT	