

NASA Conference Publication 10098

Automation and Robotics for Space-Based Systems—1991

Edited by
Robert L. Williams II
NASA Langley Research Center
Hampton, Virginia

Proceedings of a workshop
sponsored by the National
Aeronautics and Space
Administration and held at
Langley Research Center
Hampton, Virginia
December 10, 1991

MAY 1992

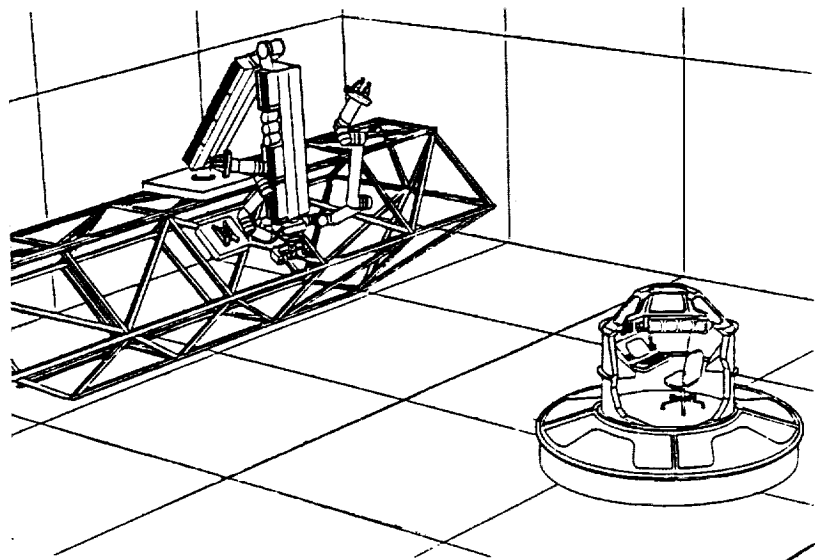

N92-27763
--THRU--
N92-27782
Unclas
0092910

63/63

(NASA-CP-10098) AUTOMATION AND ROBOTICS FOR
SPACE-BASED SYSTEMS, 1991 (NASA) 254 p

X

NASA

National Aeronautics and
Space Administration

Langley Research Center
Hampton, Virginia 23665-5225

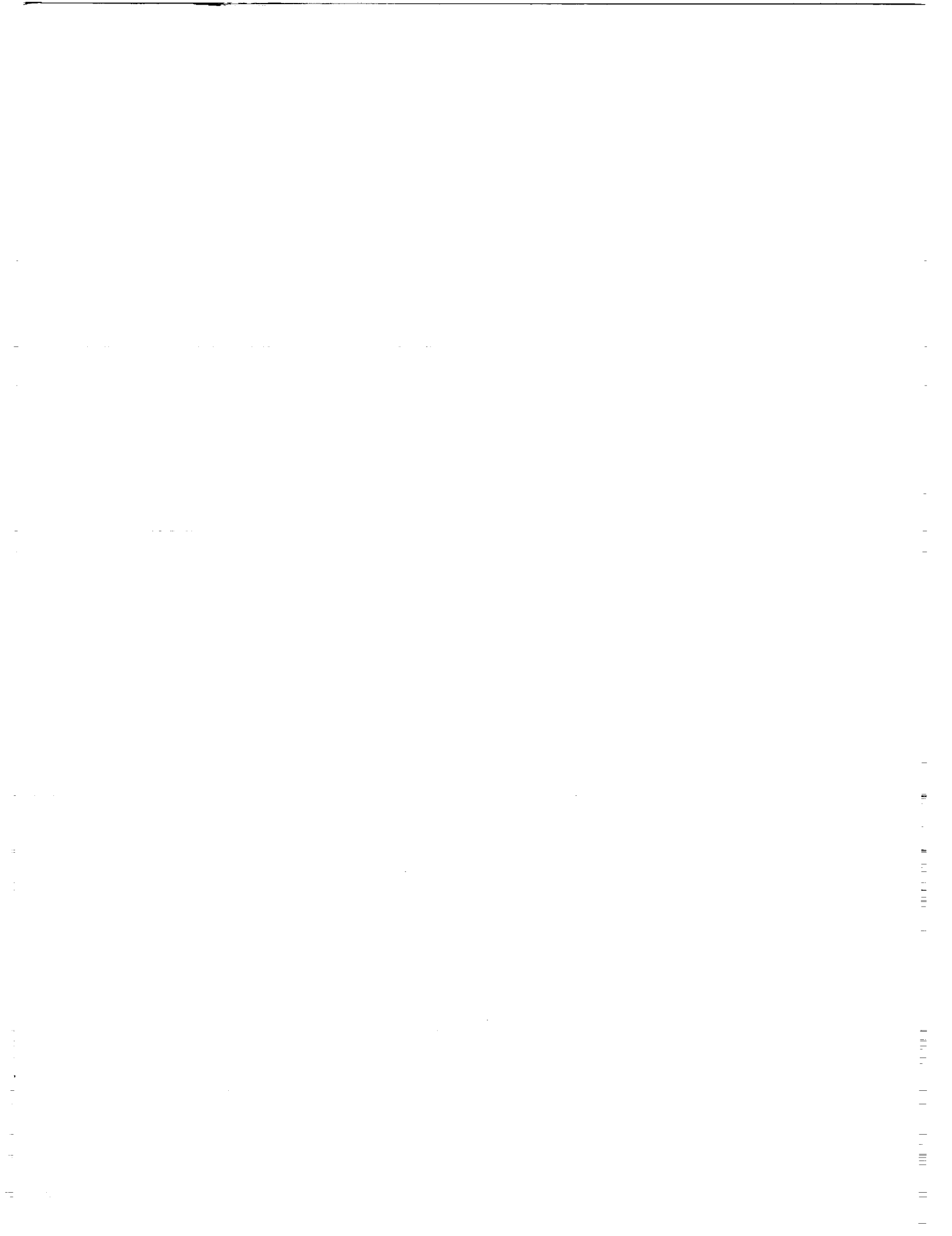

Automation and Robotics for Space-Based Systems - 1991

Preface

A NASA Langley workshop on Automation and Robotics for Space-Based Systems was held on December 10, 1991, from 8:30 a.m. to 4:00 p.m. This conference proceedings document presents the overhead slides from each speaker at this event. The purpose of this in-house workshop was to assess the state-of-the-art of automation and robotics for space operations from a Langley Research Center perspective and to identify areas of opportunity for future research. The workshop was sponsored by the Guidance, Navigation, and Control Technical Committee, chaired by Dr. Raymond C. Montgomery.

Nineteen talks were given, reflecting a high level of interest in the field of automation and robotics at NASA Langley. Over half of the presentations came from the Automation Technology Branch, covering telerobotic control, EVA and IVA telerobotics, hand controllers for teleoperation, sensors, neural networks, and automated structural assembly, all applied to space telerobotic missions. Other talks covered RMS active damping augmentation, space crane work, modeling, simulation, and control of large, flexible space manipulators, and virtual passive controller designs for space robots.

The 1991 NASA Langley Workshop on Automation and Robotics for Space-Based Systems provided a good overview of current effort in this field at NASA Langley. The workshop served to open or renew lines of communication between various researchers working in diverse areas of automation and robotics. This document summarizes the talks of this workshop using the presentation overheads.

Robert L. Williams II



Automation and Robotics for Space-Based Systems - 1991

Table of Contents

<i>"Summary of Compliant and Multi-Arm Control at Langley Research Center"</i>	
Fenton W. Harrison	1
<i>"EVA Robotics for Space Station Freedom"</i>	
Robert L. Williams II	19
<i>"IVA Robotics for Space Station Freedom"</i>	
Sharon M. Jones	35
<i>"Hand Controller Study of Force and Control Mode"</i>	
A. Terry Morris	47
<i>"Coherent Laser RADAR Vision System and Taskspace Identification"</i>	
Hal Aldridge	59
<i>"Neural Networks Modeling and Control of Dynamical Systems"</i>	
Don Soloway	67
<i>"Adaptive Artificial Neural Network for Autonomous Robot Control"</i>	
Michael K. Arras	85
<i>"RMS Active Damping Augmentation"</i>	
Michael G. Gilbert	93
<i>"A Space Crane Concept for Performing On-Orbit Assembly"</i>	
John T. Dorsey	111
<i>"Analysis and Testing of a Space Crane Articulating Joint Testbed"</i>	
Thomas R. Sutter and K. Chauncey Wu	123

Table of Contents (Con't)

<i>"Automated Assembly of Large Space Structures"</i>	
Overview, Marvin D. Rhodes	137
Machine Vision, Eric G. Cooper	153
End-Effector Microprocessor, William R. Doggett	179
Panel Installation, Cuong Quach	187
Expert System, Cheryl L. Allen	195
Future Work, Ralph Will	203
<i>"On the Use of Torque-Wheels For the Control of Large, Flexible, Space-Based Telerobotic Arms"</i>	
Dave Ghosh	207
<i>"Modeling, Control, and Simulation of Flexible Link Robotic Systems"</i>	
Sean P. Kenny	223
<i>"Passive Dynamic Controllers for Non-Linear Mechanical Systems"</i>	
Minh Phan	233

**Summary of Compliant and Multi-Arm Control at
Langley Research Center**

by

Fenton W. Harrison

N92-27764

Single Arm System

Single Arm Philosophy

- a. Axis Systems
- b. Control Systems
- c. Results

Single Arm Axis System

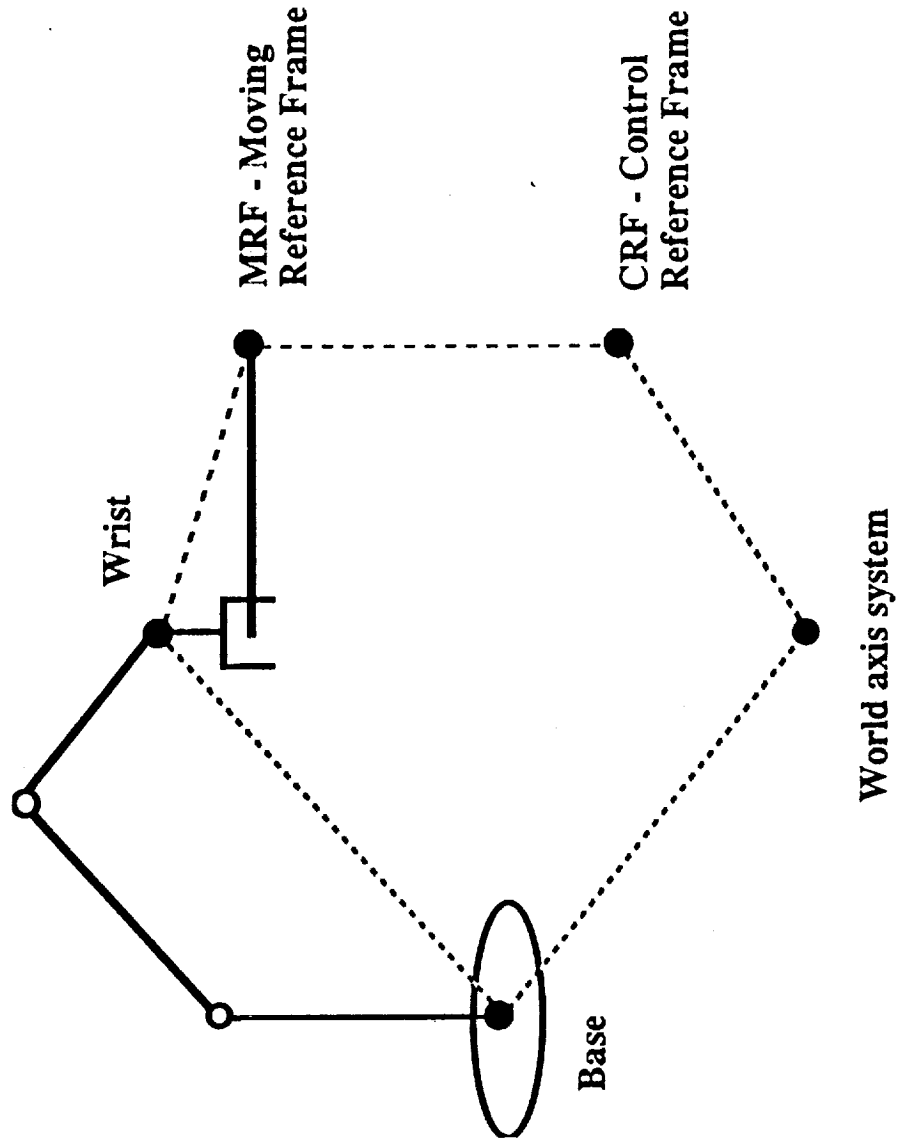

Single Arm Control Systems

1. Manual Control
2. Position control
3. Vision control
4. Force control

Single Arm Hand Controller Axis System

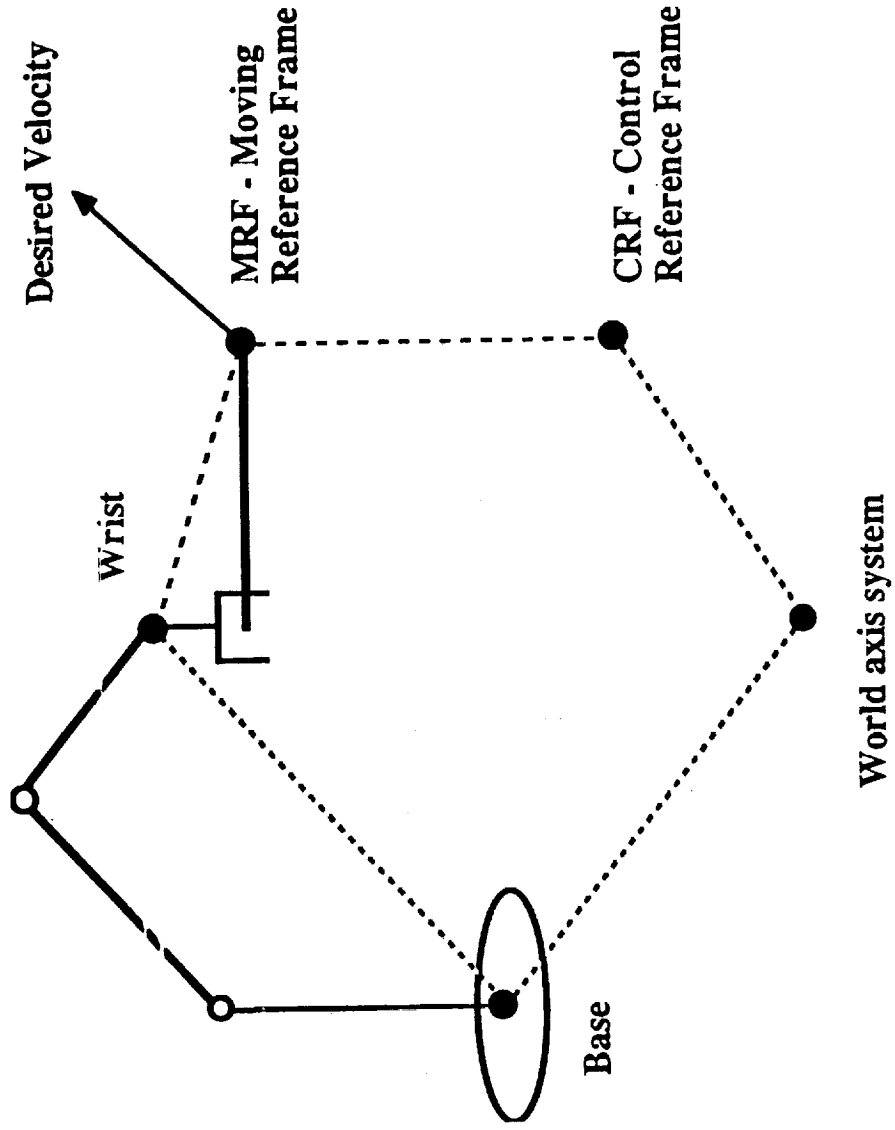

ISRL HAND CONTROL FLOW DIAGRAM

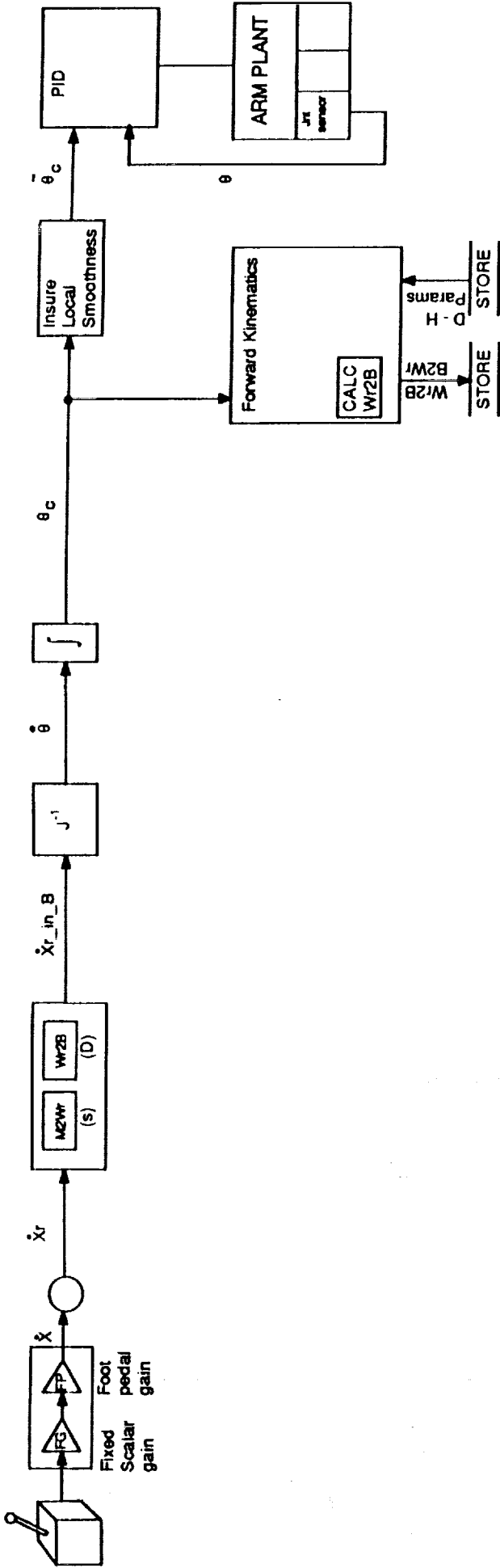

Single Arm Position Axis System

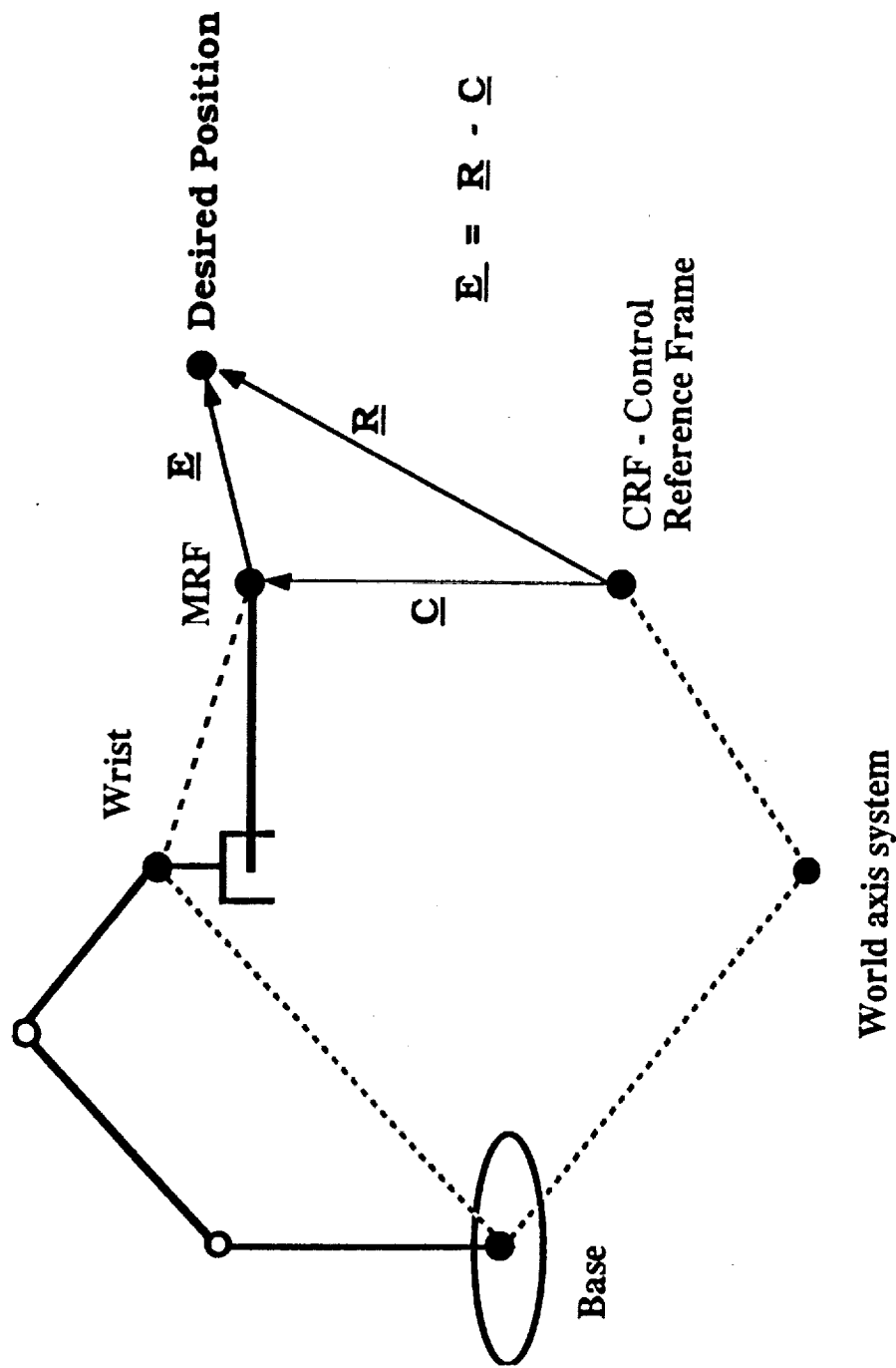

ISRL POSITION FLOW DIAGRAM

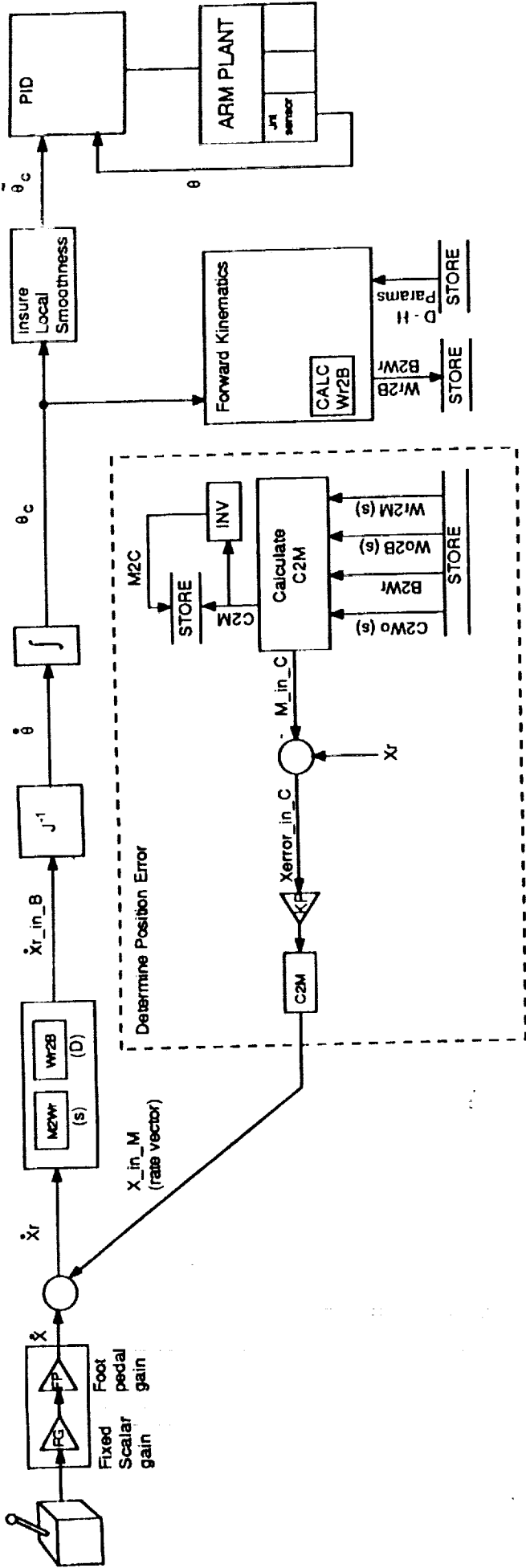

Single Arm Vision Axis System

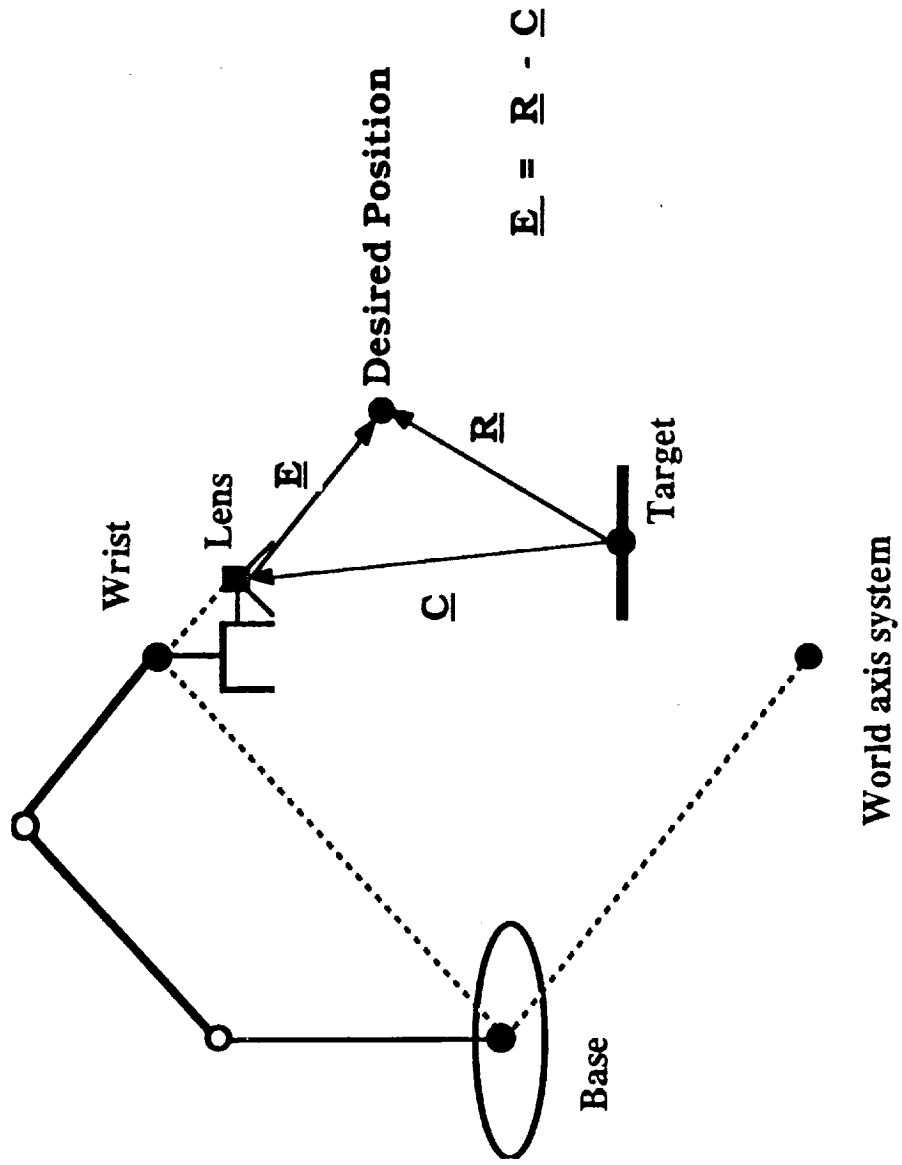

Single Arm Force Axis System

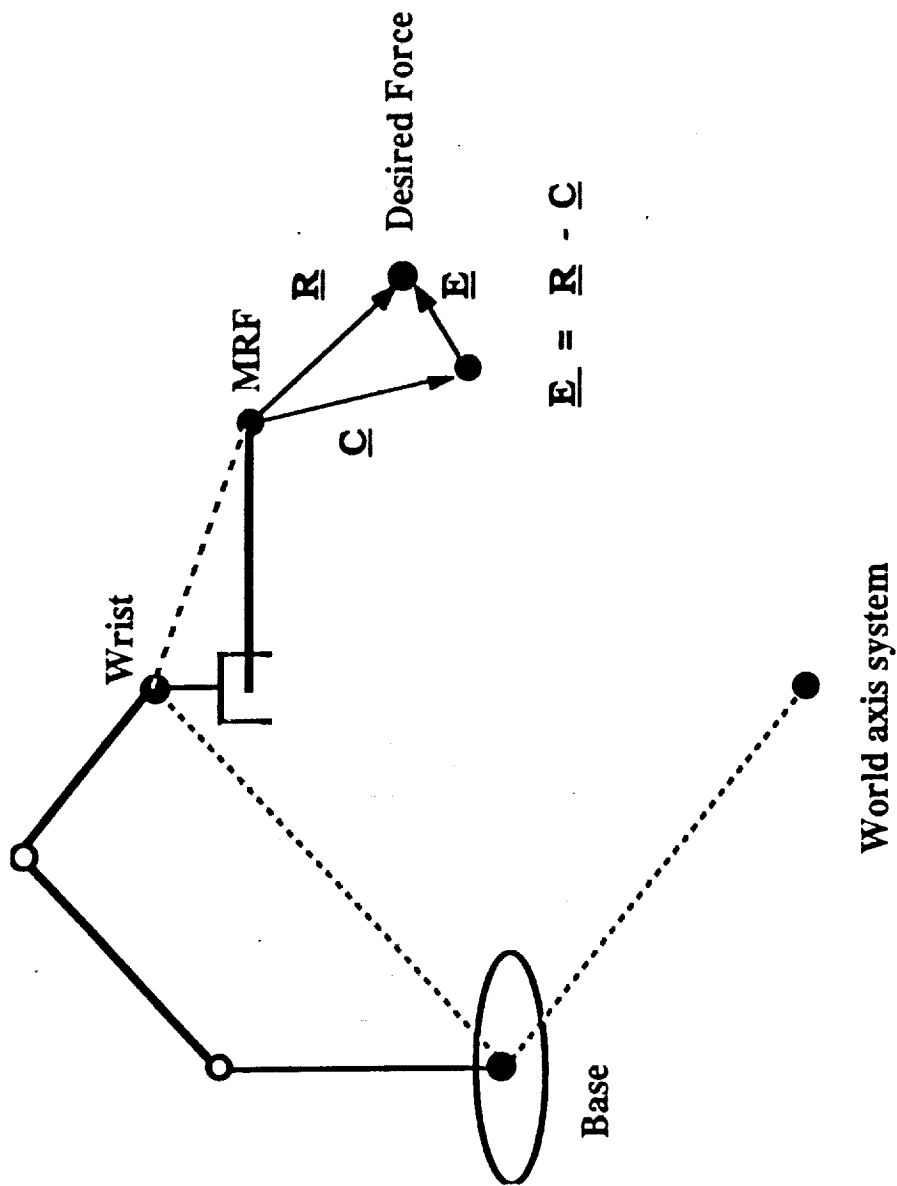

ISRL SINGLE ARM FORCE CONTROL FLOW DIAGRAM

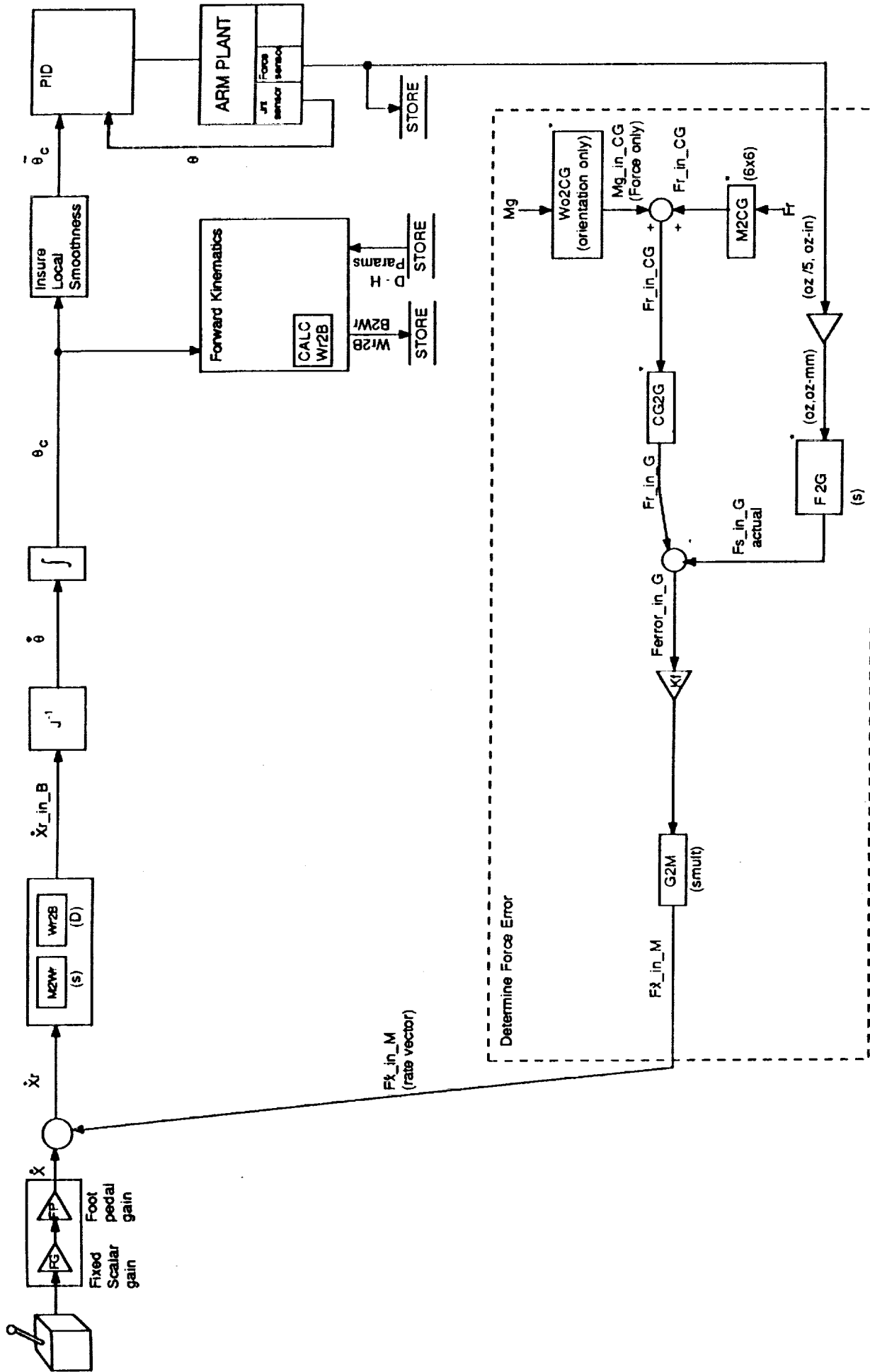

Multi Arm System

Multi Arm Philosophy

- a. **Axis Systems**
- b. **Control Systems**
- c. **Results**

Multi Arm Axis System

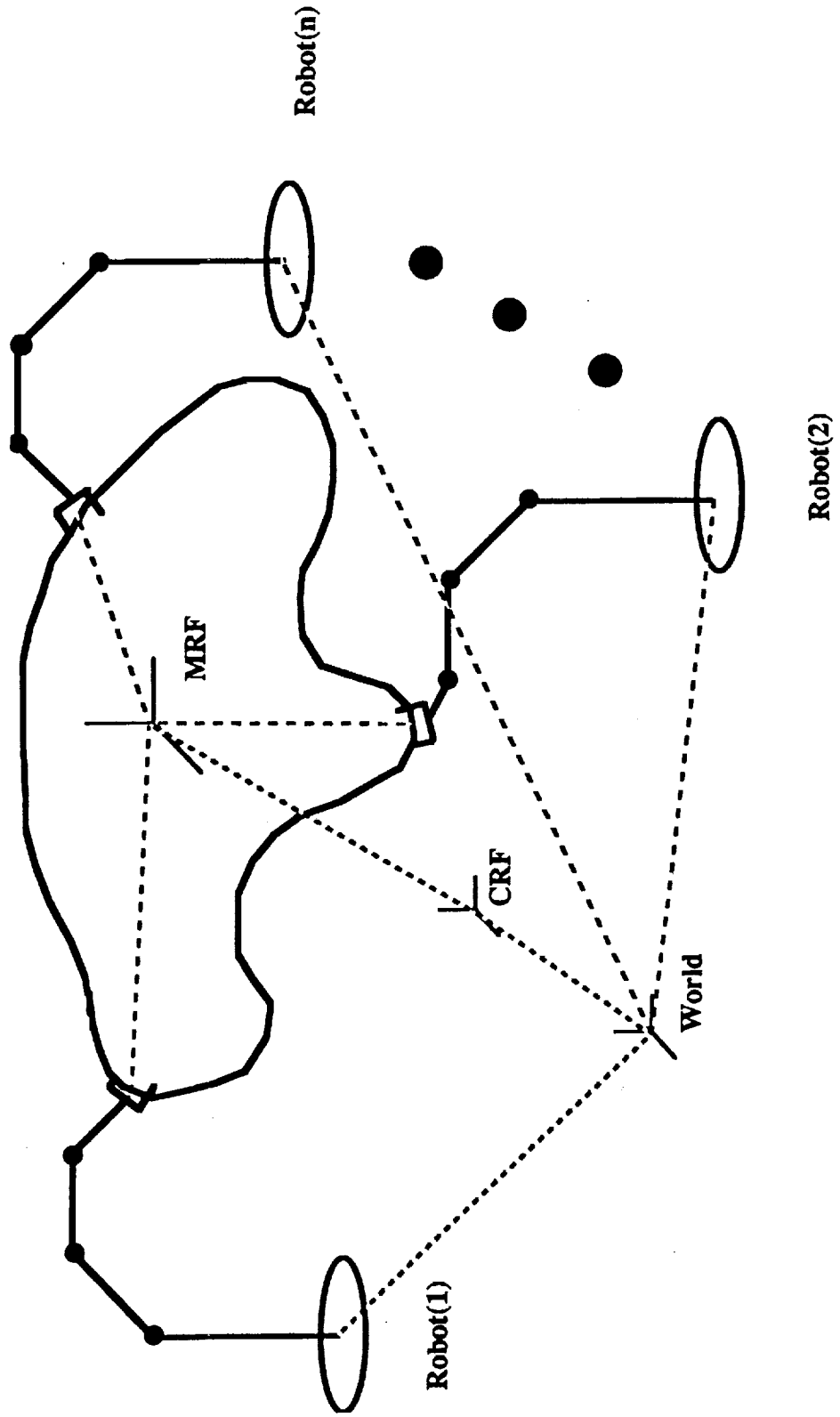

Dual Arm Hand Control Axis System with Control Signals

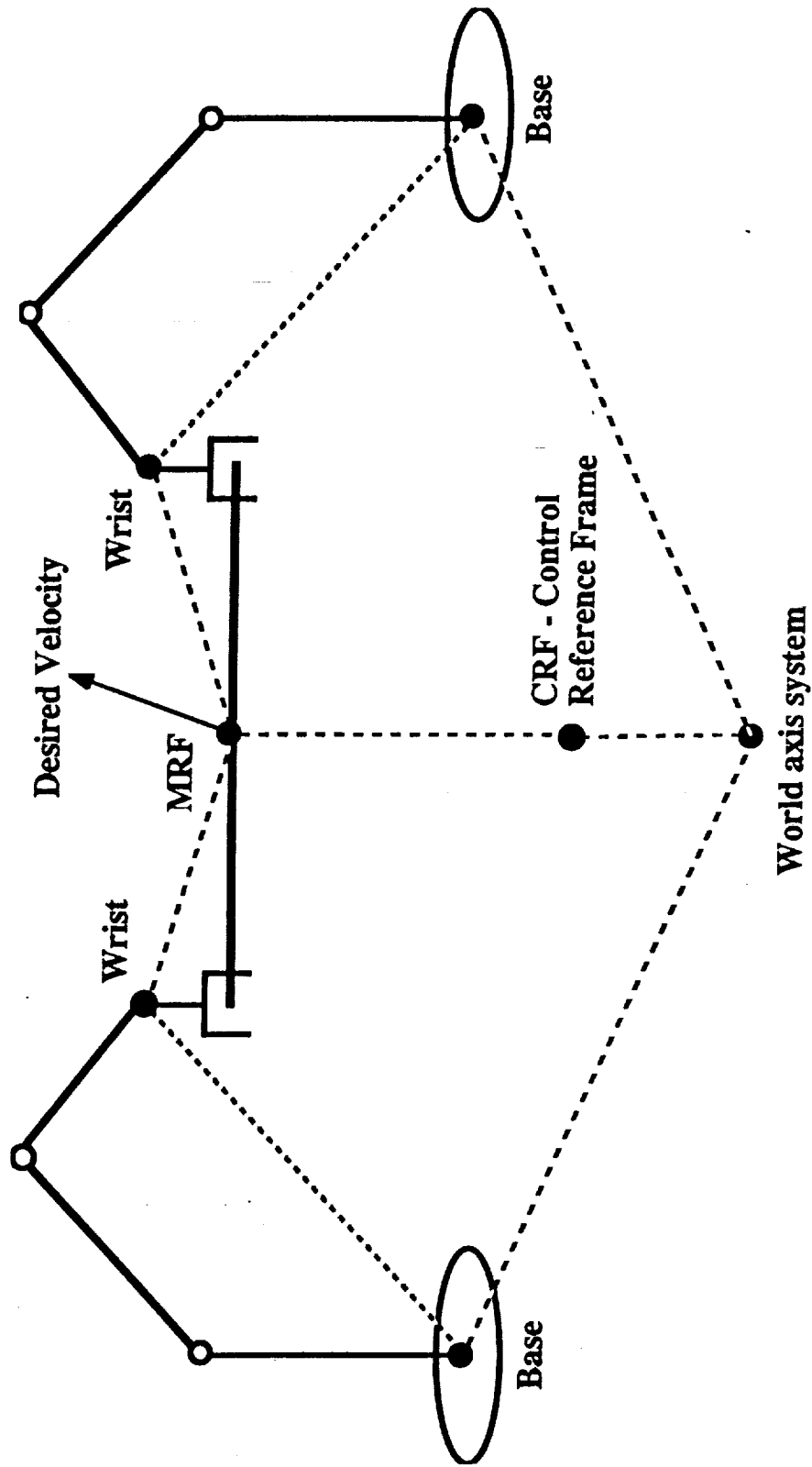

SUMMARY

Velocity Control

- Natural for operator input.
- Summing of sensor input.

Single Arm Philosophy

- Uses of sensors to correct for errors.
- Precise calibration is eliminated.

Multi Arm Philosophy

- Use many independent single arm systems to make one multi arm system.

Use of MRF and CRF

- Decouples operator from the manipulators.
- Take advantage of symmetry of task.
- To control compound manipulators.
- Tracking of objects.

Use of optimal load distribution.



**EVA ROBOTICS FOR
SPACE STATION FREEDOM**

**Dextrous Manipulator Development
(DEMAND)**

**Bob Williams
Automation Technology Branch**

N92-27765

Dexterous Manipulator Development

(DeManD)

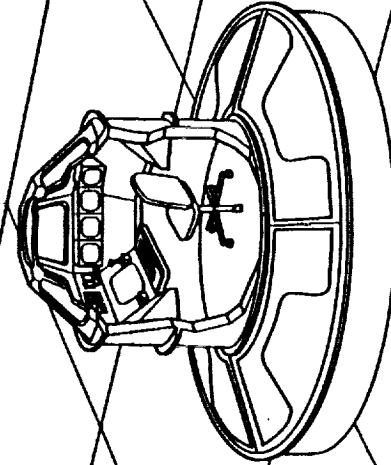
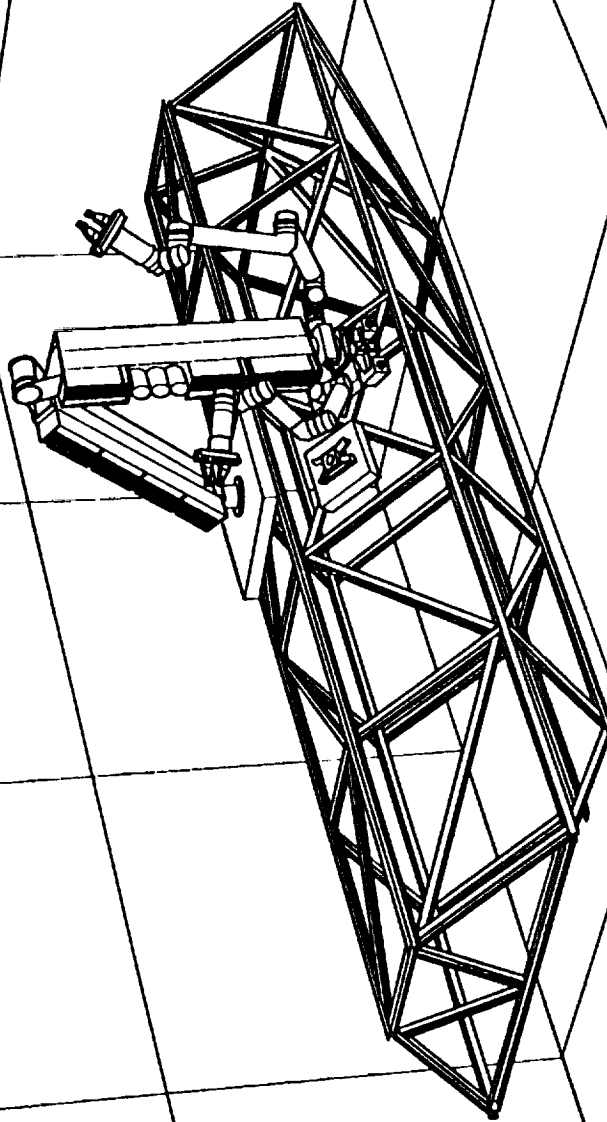

Automation Technology Branch
NASA Langley Research Center
October 1991

ATB/ISD/ESD 8-NOV-1991

The Problem

- **Current Space Station Maintenance demand exceeds capability.**
- **Increasing interest in utilizing telerobotics but limited confidence.**
- **Canadian SPDM would have to do the work.**

Projected EVA Backlog

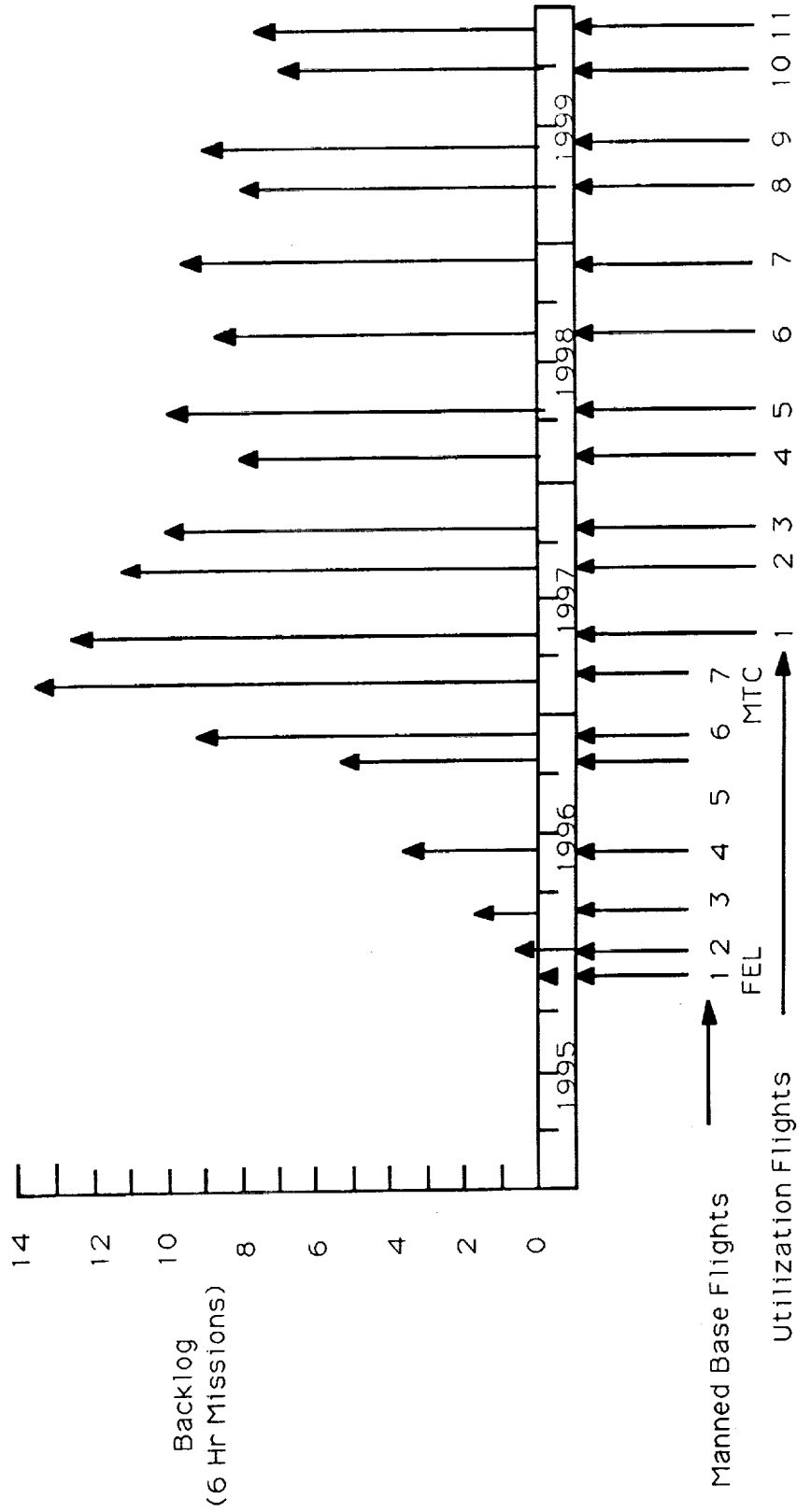

Objective

Evaluate and enhance Special Purpose Dexterous Manipulator (SPDM) utilization in realistic Space Station Freedom tasks.

Approach

- Identify opportunities to enhance SPDM operations for Space Station Freedom (SSF).
- Construct a functionally equivalent segment of SSF including SPDM.
- Apply and enhance technology to accomplish SPDM tasks.
- Demonstrate SPDM operations in a realistic environment.

Potential SPDM Tasks

- Inspection
- ORU Change Out
- Work Site Setup
- Repair

CURRENTLY PROJECTED SPDM TASKS DO NOT USE THE SPDM'S FULL CAPABILITY!

Dexterous Manipulator Development Laboratory - FY92

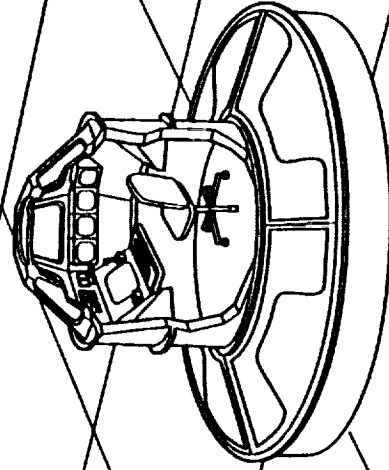
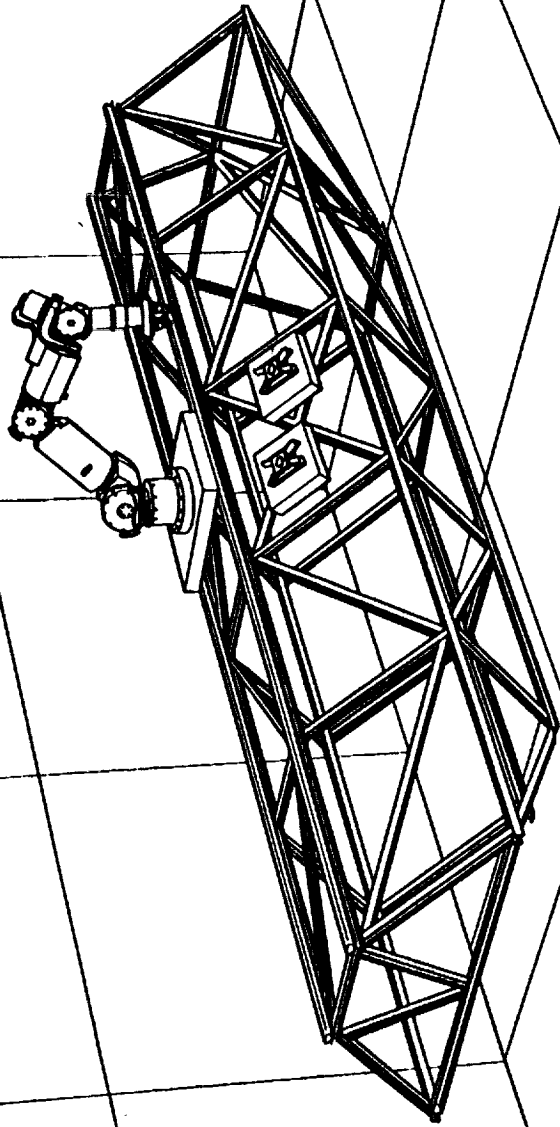

ATB/TSD/FSD 8-NOV-1991

Dexterous Manipulator Development Laboratory - FY93

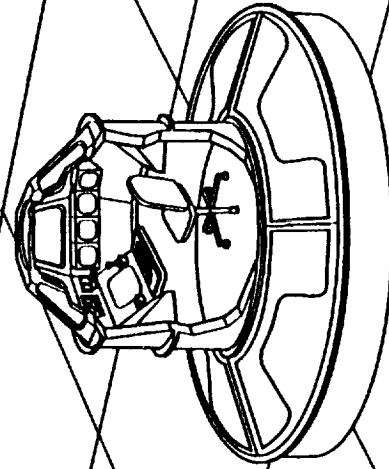
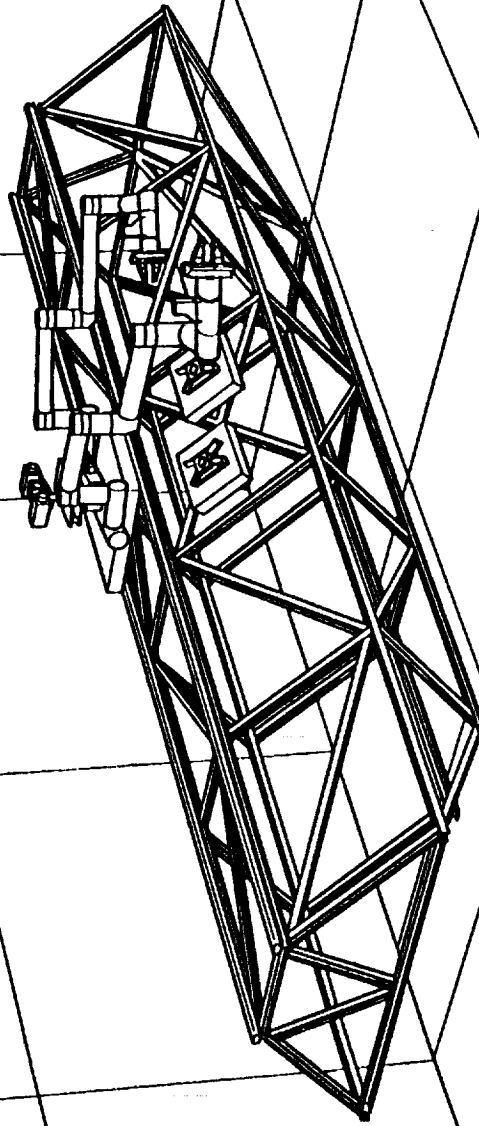

Dexterous Manipulator Development Laboratory - FY94

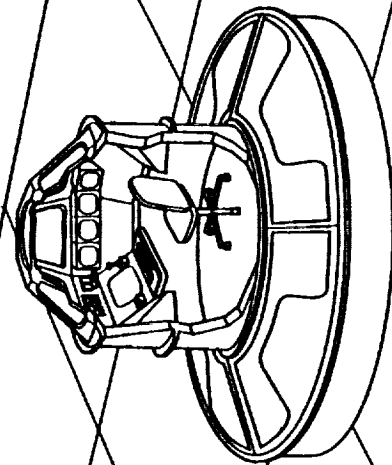
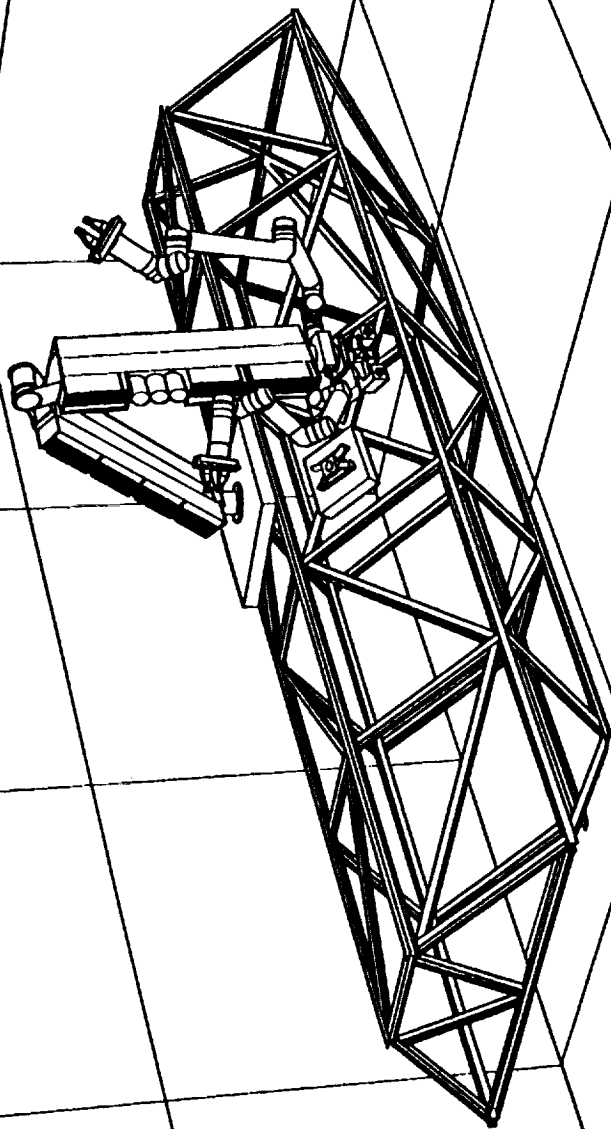

ATB/ISD/FSD 8-NOV-1991

Apply and Enhance Technology

- Rate Control
- Position Control
- Hand Controllers
- Simultaneous Shared Control
- Degree-of-Automation
- Multiple Arm Control
- Computer Hardware, Software, Communications

Apply and Enhance Technology (con't)

- Force Accommodation
- Force Reflection
- Vision Control
- Laser Ranging Control
- Redundancy, Hyper-Redundancy
- Dynamics
- Disturbance Compensation

Program Goals

- Determine reliable and efficient strategies for use of SPDM
- Offer suggestions for SPDM development and usage based on hard operational data
- Develop techniques for non-standard uses of SPDM such as
 - Inspection
 - Maintenance of robot unfriendly components
 - Emergency repairs
- Provide an open resource to test innovative ideas in a realistic environment

Summary

- Space Station Office has identified robotics as a desired approach for reducing EVA backlog.
- Telerobotic worksite setup has high potential for EVA savings.
- SSF repair is not anticipated, but capability should be available
- Program will add to existing technology base and give confidence to potential robot users.

Footnote

- FTS Hardware
- Electromagnetic "Glue Gun"

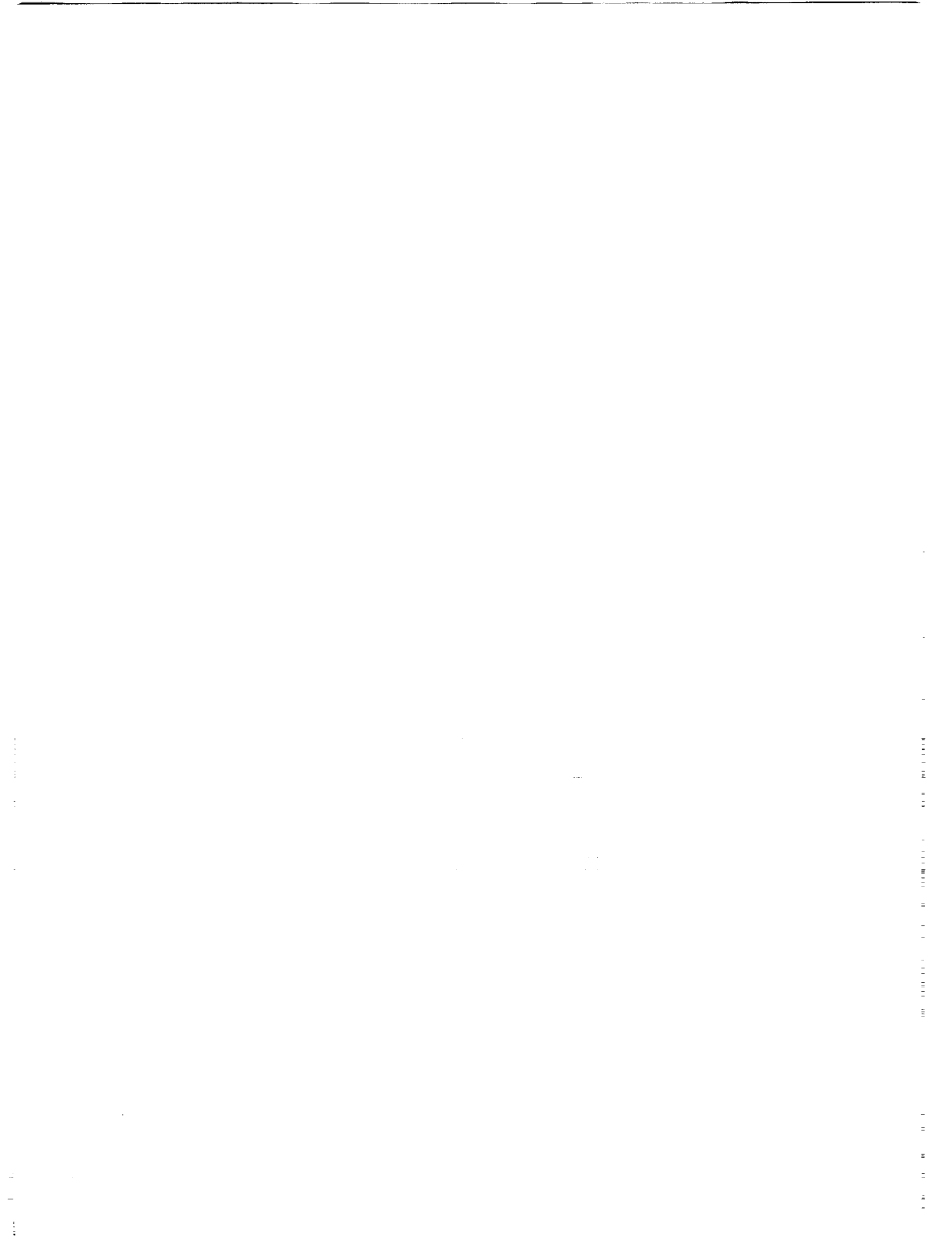

IVA Robotics for Space Station Freedom

Sharon Monica Jones
Automation Technology Branch

December 10, 1991

Objective

To increase the scientific productivity of Space Station Freedom (Spacelab) during the man-tended phase and beyond

Space Station Freedom Background

- Volume decreased
- Communication capability decreased
- Limited crew visits
- Man-tended phase
 - begins in 1996
 - will last approximately 3 years

Man-Tended Phase U.S. Lab Module Volume

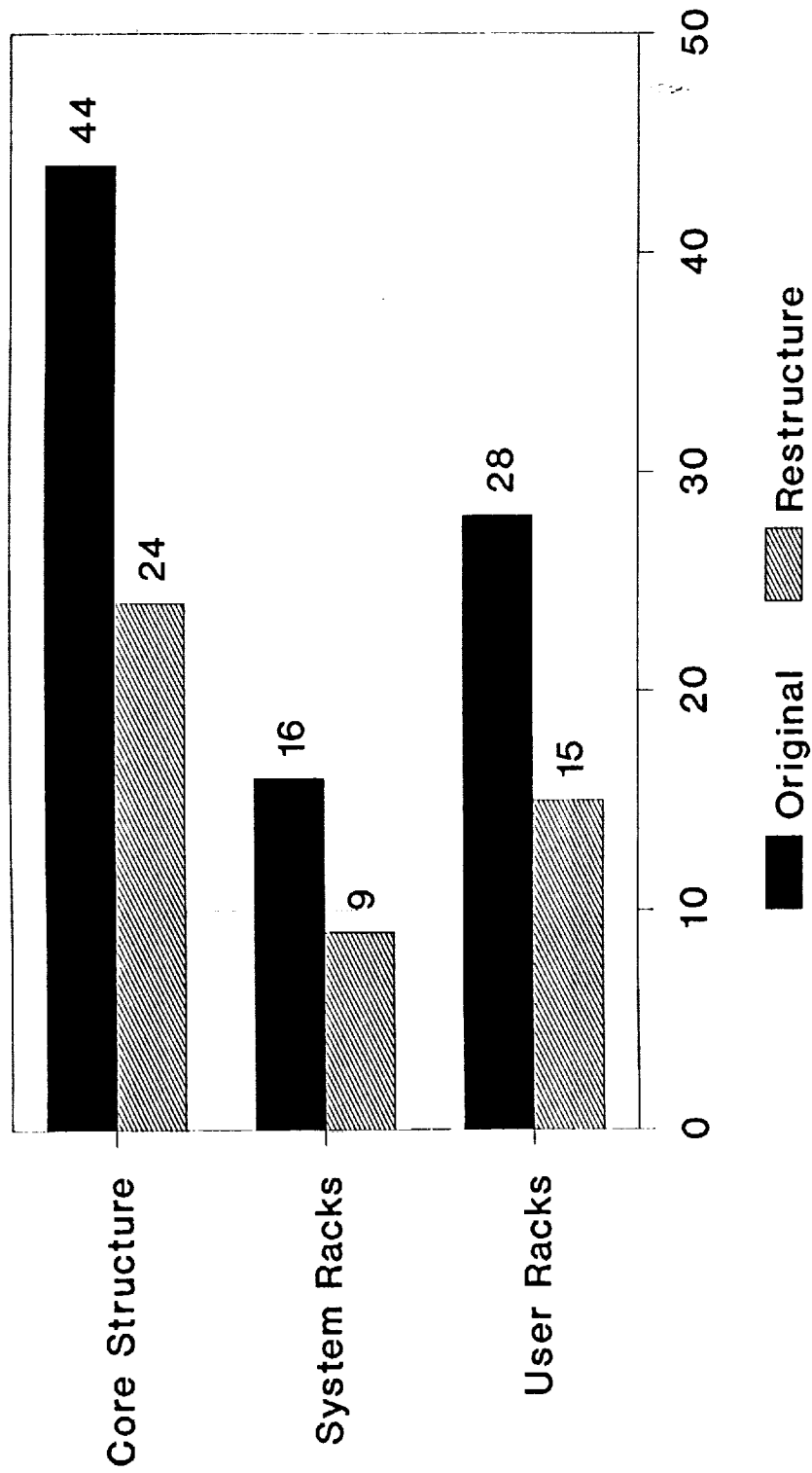

source: LaRC SSFO

IVA Robotics

Goals

- **Increase scientific productivity**
 - **more and/or extended experiments**
 - **less microgravity disturbance**
 - **in situ monitoring and inspection**
 - **more efficient rack support utilization**
- **Maintain U.S. space telerobotics capability**

IVA Robotics

ATB Program Purpose

Demonstrate an increase in the productivity of Space Station Freedom experiments through the application of automation technology in a realistic environment

IVA Robotics

Approach

- **Obtain background information**
- **Construct full scale laboratory module mockup**
- **Install telerobotic system in mockup**
- **Develop functional experiment hardware**
- **Define space IVA telerobotic criteria**

Experiment Protein Crystal Growth

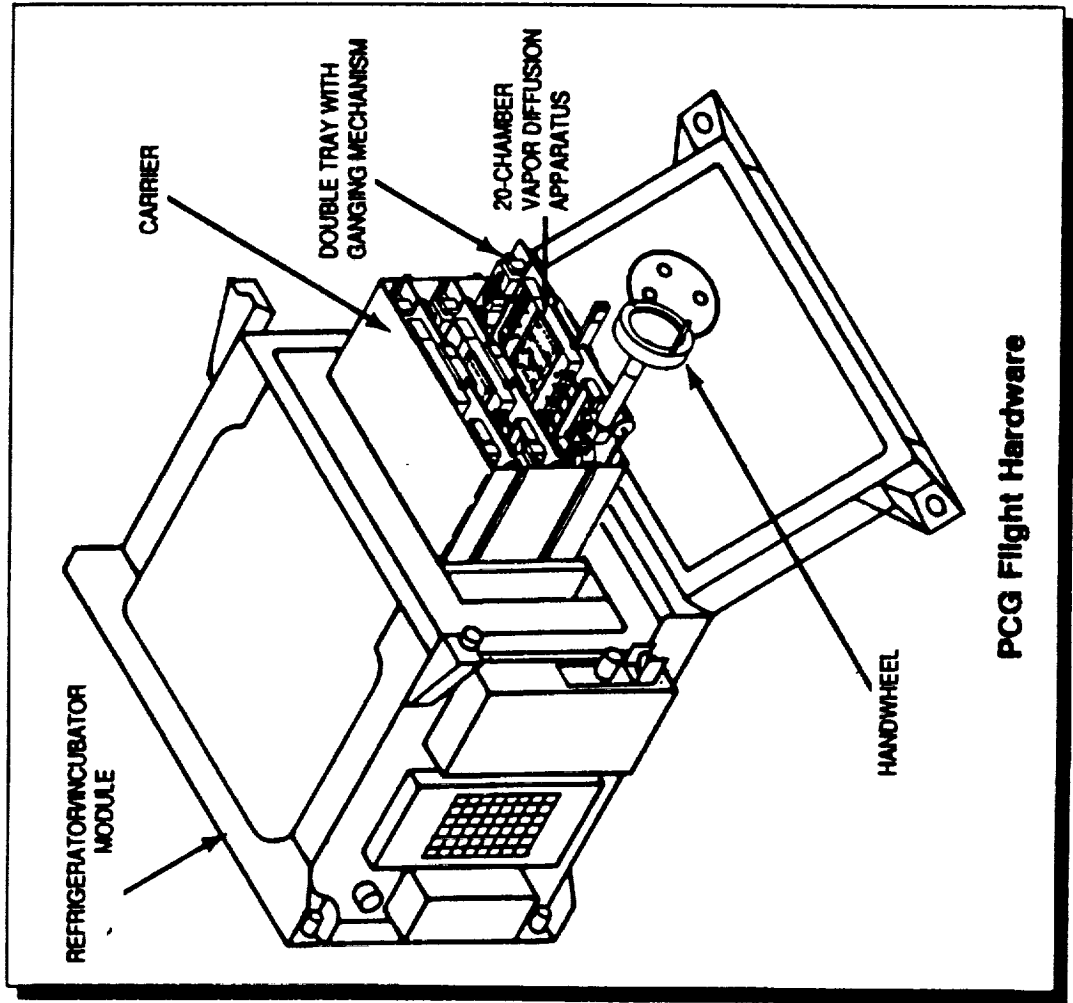

Equipment Thermal Enclosure System

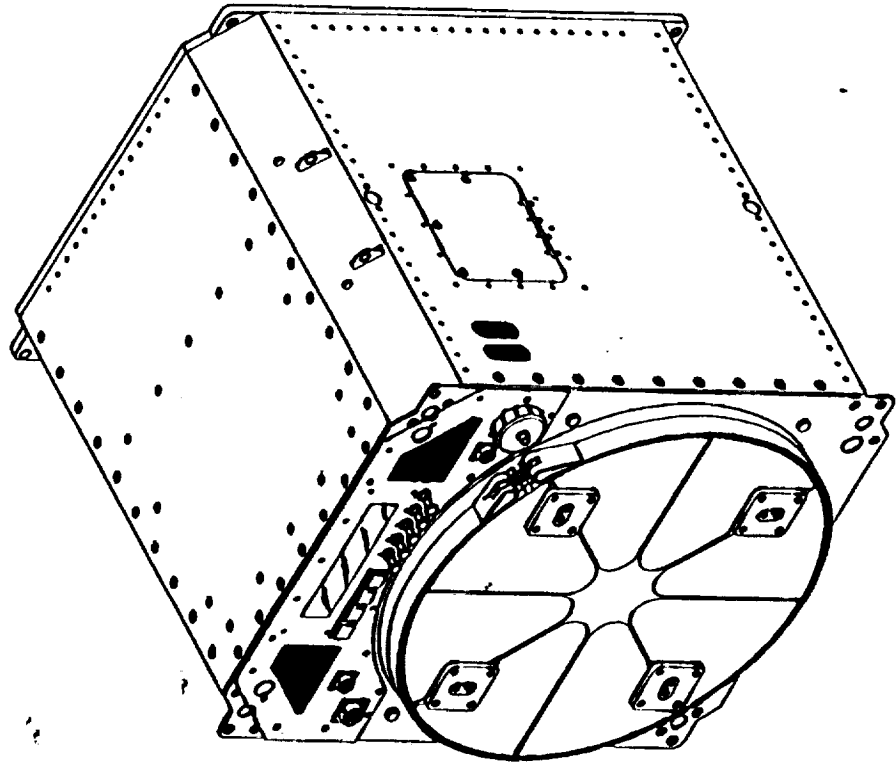

Candidate Mockup Demonstrations

SPACE STATION EXPERIMENT	SEMICONDUCTOR MATERIALS SOLIDIFICATION	PROTEIN CRYSTAL GROWTH	FLUID PHYSICS	COMBUSTION RESEARCH	FLOAT ZONE CRYSTAL GROWTH	GAS GRAIN SIMULATION	GRAVITATIONAL BIOLOGY
DEMO NO. TASK							
1 SAMPLE CHANGEOUT	DEMO 2	DEMO 1	DEMO 3		DEMO 3		
2 INSPECTION	DEMO 2	DEMO 2			DEMO 3		
2 WASTE GAS DISPOSAL	DEMO 2			DEMO 3			
3 DATA REMOVAL AND STORAGE	DEMO 3						
3 UTILITY HOOK-UPS			DEMO 3				
4 ANIMAL AND PLANT CARE						DEMO 4	DEMO 4

Preliminary Concept for IVAR

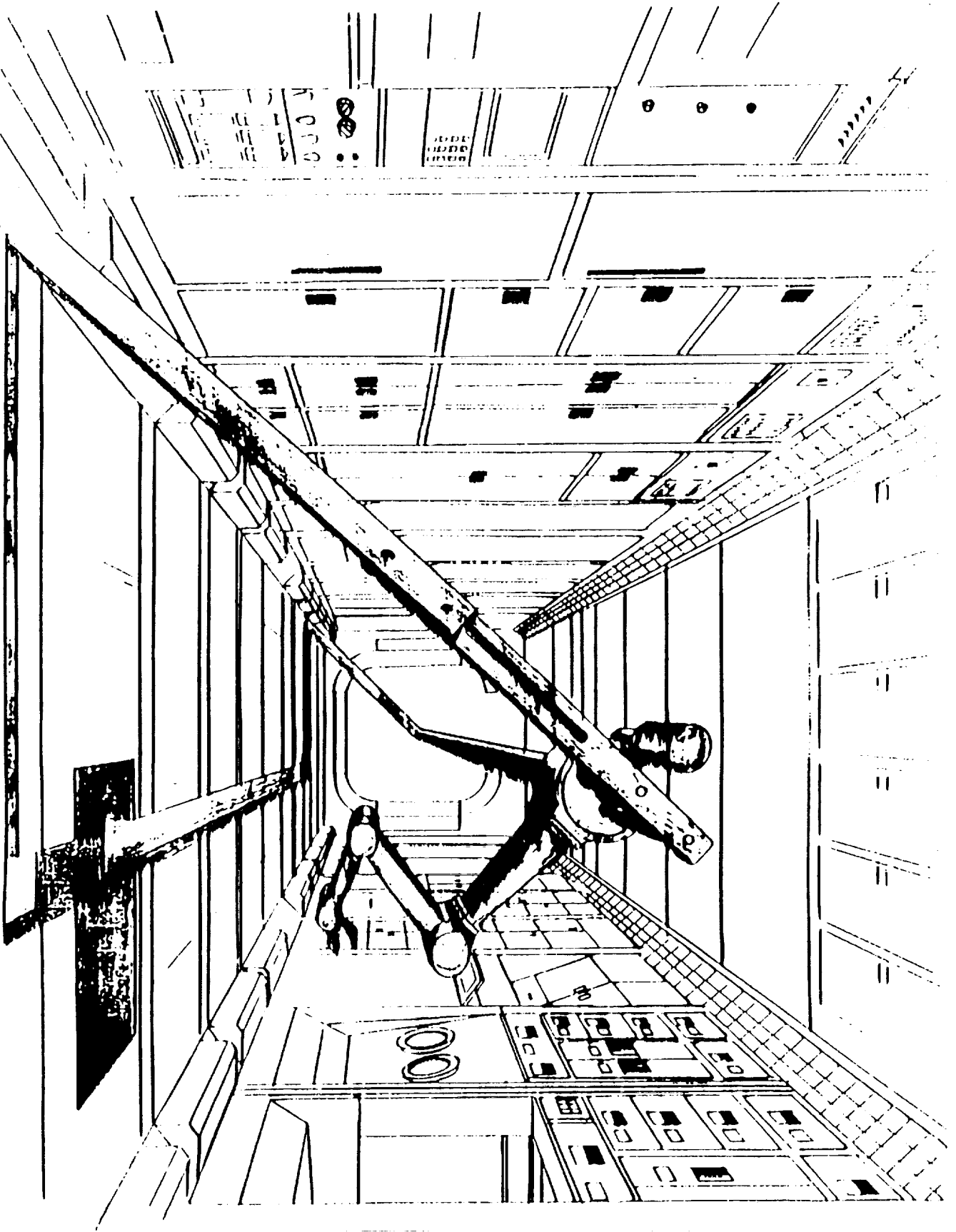

IVA Robotics

IVAR Team Members

- **L. Keith Barker**
- **Walter Hankins**
- **Sharon Monica Jones**
- **Randy Mixon**
- **A. Terry Morris**
- **Kelli Willshire**

HAND CONTROLLER STUDY OF FORCE AND CONTROL MODE

1991 NASA Langley Workshop on Automation and
Robotics for Space-Based Systems

December 10, 1991

A. Terry Morris

Information Systems Division
Automation and Technology Branch

N 9 2 - 2 7 7 6 7

HAND CONTROLLER STUDY OF FORCE AND CONTROL MODE

O OBJECTIVES

- COMPARE AND EVALUATE UTILITY AND EFFECTIVENESS OF VARIOUS INPUT CONTROL DEVICES, E.G., HAND CONTROLLERS, WITH RESPECT TO THE RELATIVE IMPORTANCE OF FORCE AND OPERATIONAL CONTROL MODE (E.G., RATE OR POSITION) FOR SPACE STATION RELATED TASKS.

O APPROACH

- STUDIES WERE DONE WITH TWO DIFFERENT MANIPULATOR SYSTEMS
INTELLIGENT RESEARCH SYSTEMS LAB (ISRL) WITH A PUMA ROBOT AND THE TELEROBOTIC SYSTEMS RESEARCH LABORATORY (TSRL) WITH THE LABORATORY TELEROBOTIC MANIPULATOR (LTM), A MASTER SLAVE SYSTEM
- THREE STUDIES WERE PERFORMED: ONE PILOT STUDY IN ISRL, ONE FULL STUDY IN ISRL, AND ONE FULL STUDY IN TSRL

METHOD

O SUBJECTS

- UNDERGRADUATE ENGINEERING/SCIENCE STUDENTS, AGES 18-29 YEARS, EIGHT IN ISRL, AND EIGHT IN TSRL. AND FOUR OTHER SUBJECTS FOR ISRL PILOT STUDY
PRACTICED TO PREDETERMINED LEVELS OF PERFORMANCE

O INDEPENDENT VARIABLES

- UP TO FOUR TYPES OF FORCE INFORMATION:
NONE, REFLECTION, ACCOMMODATION, REFLECTION PLUS ACCOMMODATION
- THREE HAND CONTROLLERS: KRAFT, HONEYWELL, TWO 3 DOFS
- THREE TASKS: STRUT INSERTION, THERMAL BLANKET, DUAL-PEG-IN-HOLE
- TWO CONTROL MODES: RATE AND POSITION

O DEPENDENT VARIABLES

- TASK AND SUB TASK COMPLETION TIMES, FORCES EXERTED, SUBJECTIVE ASSESSMENTS

O DATA COLLECTION

- DEPENDENT VARIABLE DATA COLLECTED AUTOMATICALLY BY THE SYSTEM.
- VIDEO AND AUDIO RECORDING.

ISRL EXPERIMENTAL DESIGN - PILOT EXP

COMPLETELY RANDOMIZED REPEATED MEASURES DESIGN

(2) HAND CNTRL		KRAFT			HONEYWELL			
(3) TASK		1	2	3	1	2	3	
(2) FORCE		0,1	0,1	0,1	0,1	0,1	0,1	
GENDER	SUBS	TRIALS						
1	1	1-3						
	⋮							
2	2	1-3						
	3	1-3						
	⋮							
2	4	1-3						

Do all tasks (in randomized order) within each hand controller, counter balance for force and not force
 Total of 12 conditions per subject, three trials each.

ISRL EXPERIMENTAL DESIGN

(3) HAND CNTRL	NON - FORCE REFLECTING	FORCE REFLECTING	
	1 TWO 3 DOFS	2 HONEYWELL	3 KRAFT
(4) FORCE	0 1	0, 1, 2, 3	0, 1, 2, 3
SUBS TRIALS			
1 1-3			
.			
.			
.			
8 1-3			

Counter balance for force conditions
 Total of 10 conditions per subject, three trials each.
 Levels of force are : none (0), force accommodation (1),
 force reflection with accommodation (2),
 modified force reflection with accommodation (3)

TSRL FINAL EXPERIMENTAL DESIGN

(2) TASK		1 (peg)	2 (blanket)
(2) FORCE		0,1	0,1
GENDER	SUBS TRIALS		
1	1 1-3		
	2 1-3		
	3 1-3		
	4 1-3		
2	5 1-3		
	6 1-3		
	7 1-3		
	8 1-3		

One-half subjects practice with force reflection, and one-half practice without it.
 Test with opposite conditions.
 Do both tasks (in randomized order) , counter balance for force and not force
 Total of 4 conditions per subject, three trials each. (8 subjects)
 Force: 0 = no force reflection, 1 = force reflection

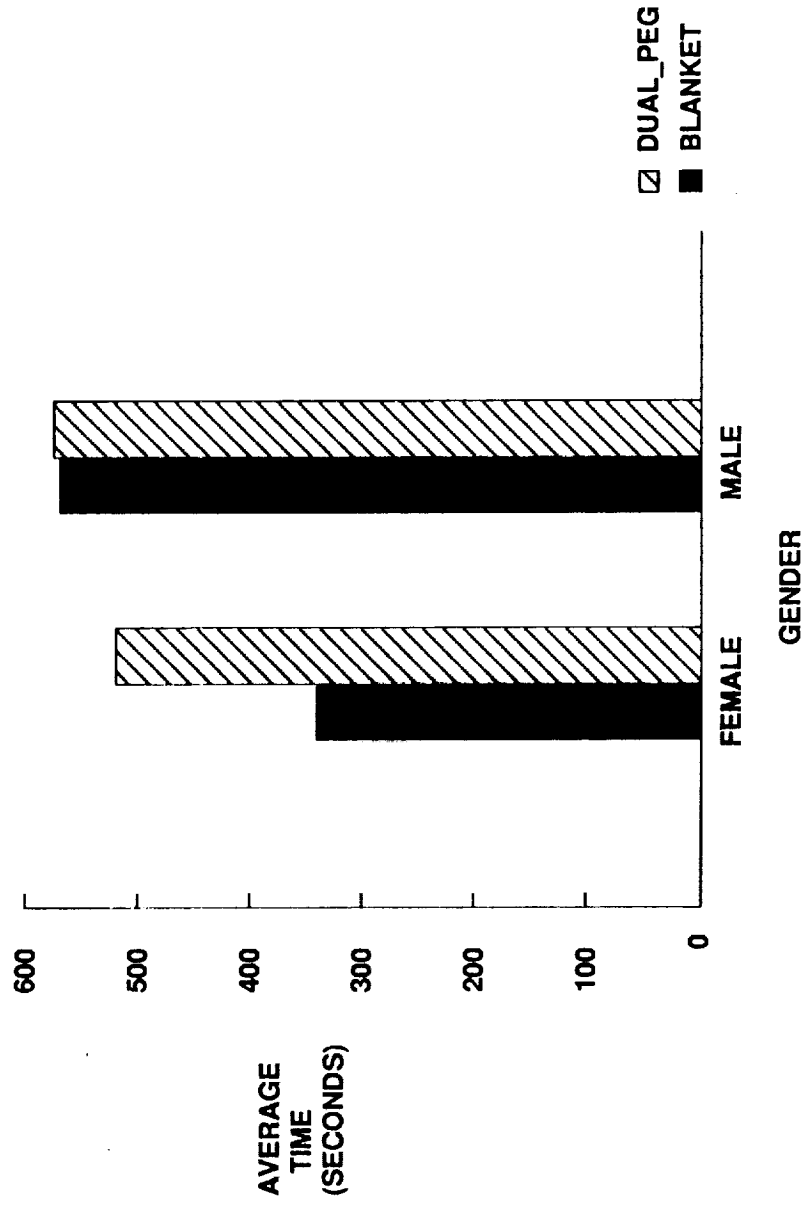

SIGNIFICANT TASK BY GENDER INTERACTION IN TSRL

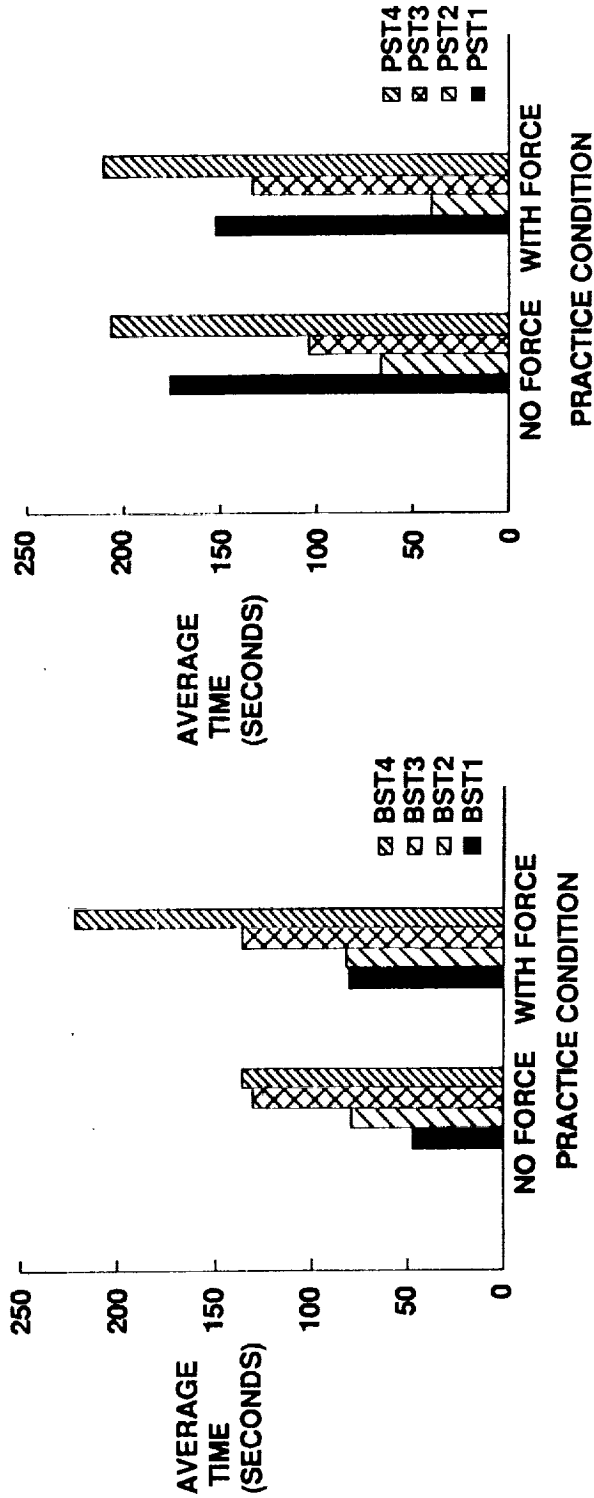

(a) Thermal blanket task

(b) Dual peg task

SIGNIFICANT PRACTICE BY TASK BY SUBTASK INTERACTION IN TSRL

FACTOR ANALYSIS SUMMARY OF RESULTS

TOP THREE OUT OF SEVEN PRINCIPAL COMPONENTS (LINEAR COMPOSITES) FOR EACH CONDITION AND PERCENT OF VARIANCE EXPLAINED BY THEM

	<u>BLANKET. NO FORCE</u>	<u>BLANKET. FORCE</u>	<u>DUAL-PEG. NO FORCE</u>	<u>DUAL-PEG. FORCE</u>
COMPONENT 1	HC CHAR (22.9%)	DEMANDS&TIME (22.775 %)	FRUSTRATION, TASK LOAD (24.896 %)	OVERALL CONDIT, AND TASK LOAD (20.202 %)
COMPONENT 2	TASK RANK/LOAD (20.826)	HC CHAR (18.979)	RANK (15.269)	TEMP DEMAND & EFFORT (PHYS) (NEG) (20.167)
COMPONENT 3	HANDSIZE (17.601)	HANDSIZE (15.823)	PERFORMANCE BY HANDSIZE (14.477)	HANDSIZE BY PERFORMANCE (19.271)
CUMMULATIVE PERCENT VARIANCE	61.327	57.577	54.637	59.64

SUMMARY AND CONCLUSIONS

O TSRL STUDY

THERE WAS NO DIFFERENCE BETWEEN FORCE REFLECTION AND NO FORCE FOR THE TASK TIME DATA HOWEVER, SUBJECTIVELY MORE PARTS OF THE BODY WERE IDENTIFIED AS EXPERIENCING DISCOMFORT AND THE FORCE REFLECTION CONDITIONS HAD SOMEWHAT MORE SUBJECTIVE TASK LOAD DEMANDS

FEMALES PERFORMED THE THERMAL BLANKET TASK MORE QUICKLY THAN MALES EVEN THOUGH GENDER WAS NOT CORRELATED WITH QUESTIONS ABOUT COORDINATED MOVEMENTS

THERE WAS LITTLE RELATIONSHIP BETWEEN AVERAGE TASK TIMES AND MENTAL WORKLOAD RATINGS OR TOTAL TASK LOAD INDEX MEASURES

THE KRAFT CONTROLLER WAS SIGNIFICANTLY MORE ACCEPTABLE FOR PERFORMING THE THERMAL BLANKET TASK THAN THE DUAL PEG TASK IN THE AREAS OF TRANSLATION, SINGLE AXIS MOVEMENTS, FINE MOVEMENT, AND GRIP ACCEPTABILITY.

O CONCLUSIONS

RESULTS FROM THE TSRL STUDY AGREE WITH JSC STUDY IN THAT NO DIFFERENCE WAS FOUND BETWEEN FORCE REFLECTION AND NO FORCE FOR TASK TIME DATA

HOWEVER, GENDER DIFFERENCE HAS NOT BEEN PREVIOUSLY REPORTED AND IS AN AREA FOR FUTURE INVESTIGATION

RESULTS FROM TSRL AND ISRL STUDIES WILL BE AVAILABLE FOR THE SPACE STATION PROGRAM TO USE IN MAKING DECISIONS AND DESIGNING FOR SPACE TELEROBOTS

RESULTS OF TELEROBOTIC HAND CONTROLLER STUDY USING FORCE INFORMATION AND RATE CONTROL

Kelli F. Willshire, F. Wallace Harrison, and Edward F. Hogge

Automation Technology Branch

Ext. 41965 December 1991

RTOP 595-11-22-01

Code RC

WBS 43

Research Objective

To evaluate the operator task performance and subjective workload of kinesthetic force feedback and/or local force accommodation as used with three different input control devices (e.g., hand controllers) operating in rate control mode for a Space Station Freedom related task.

Approach

Two studies were performed in the Intelligent Systems Research Laboratory with PUMA robots remotely operated under rate control using only video camera views without any direct vision. The first, a pilot study, consisted of four inexperienced subjects performing three tasks with two hand controllers, both with and without kinesthetic force feedback, e.g., force reflection. The results were used to select the dual-peg-in-hole task for the second study. For that study, eight new subjects performed the dual-peg task using three hand controllers without any force assistance, with local force accommodation, force reflection combined with local accommodation, and a modified force reflection with local accommodation.

Accomplishments

All testing has been completed, and the data (except energy) has been reduced. Statistical analysis has been started. Preliminary analysis indicates that there may be a difference between the force conditions for one of the hand controllers (e.g., Honeywell six degree-of-freedom). For that hand controller, the condition of force reflection combined with local force accommodation had the longest average task completion time. Further analyses will more closely investigate these differences as well as their relationship to subjective workload measures.

Significance

Few studies have investigated the effect of combining force reflection with local force accommodation in a rate control mode. The Space Station Freedom Program is interested in such results and may use this information in deciding upon telerobotic options for the Space Station.

Future

Further analysis will test the significance of these and other results and their implications for telerobot design.

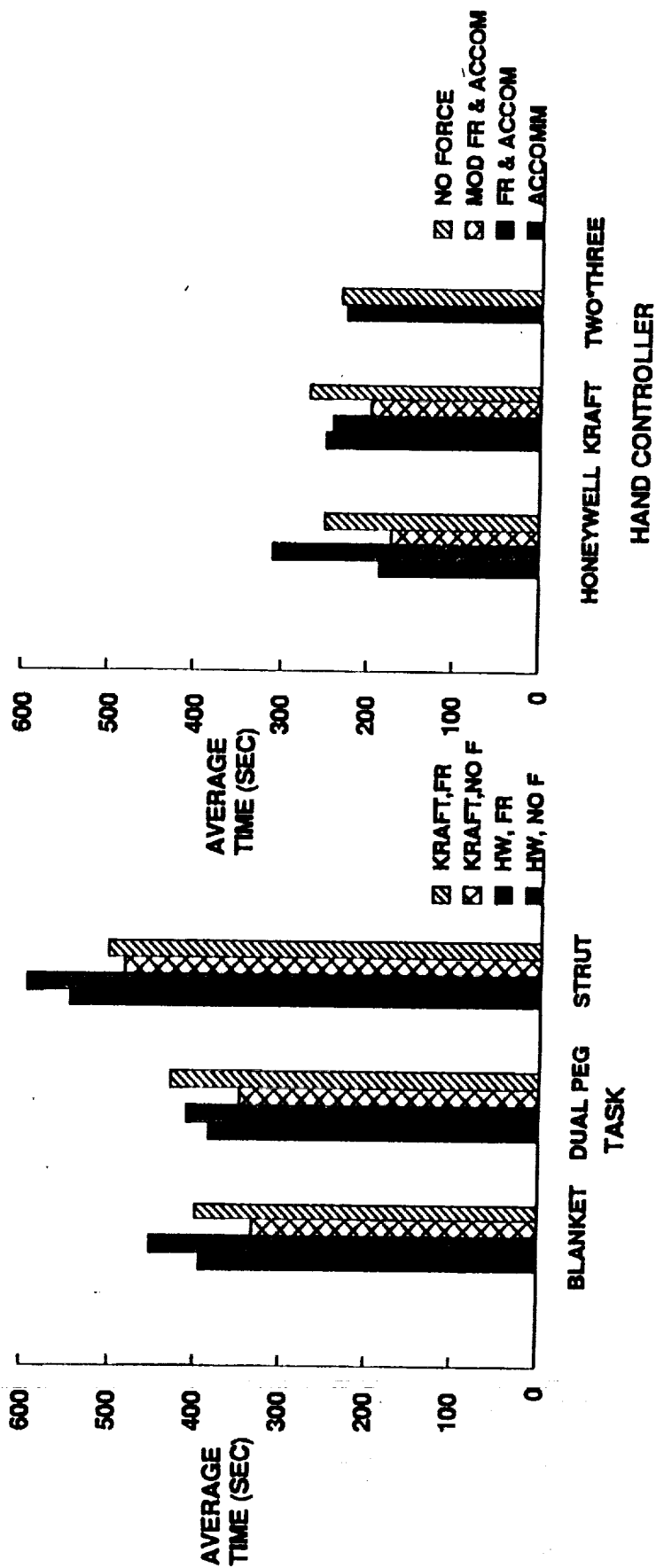

(a) ISRL pilot study mean task times.

(b) ISRL second experiment mean times for dual-peg task.

ISRL HAND CONTROLLER STUDY MEAN TIMES ACROSS TRIALS

Coherent Laser RADAR Vision System and Taskspace Identification

Hal Aldridge

NASA Langley Workshop on Automation and
Robotics for Space-Based Systems
December 10, 1991

N 9 2 - 2 7 7 6 8

Why Laser Radar

- Need for quick and accurate 3-D information to complete telerobotic tasks
- Advantages over radio wave based RADAR
 - Shorter minimum range
 - Smaller beamwidth for higher resolution
- Video 3-D imaging techniques are computationally intensive and require a light source
- SONAR cannot be used in space applications

COHERENT LASER RADAR

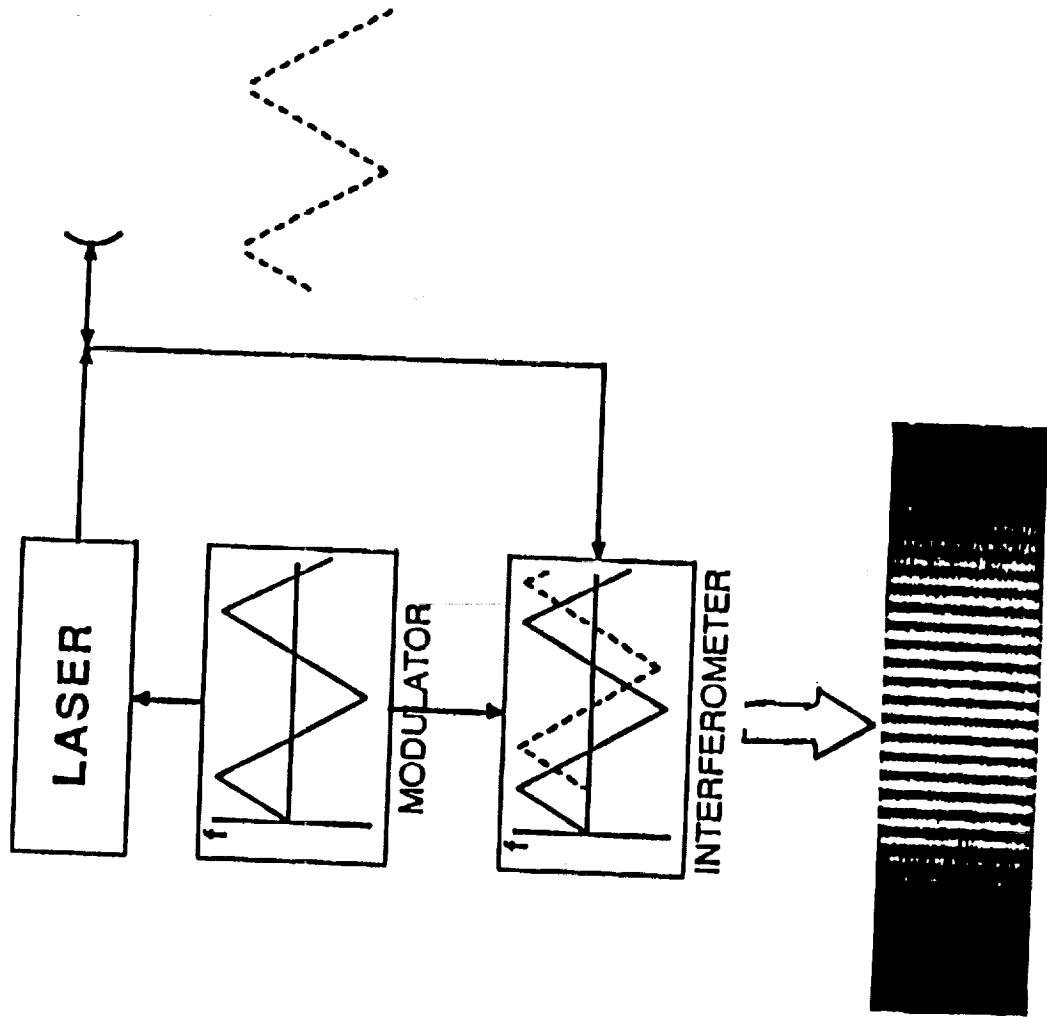

Why Frequency Modulated Continuous Wave (FMCW) Laser Radar

- Unambiguous Range Measurement
- High Resolution
- Faster and more accurate than Amplitude Modulated (AM) laser radars
- Insensitive to lighting conditions

FMCW LASER BLOCK DIAGRAM

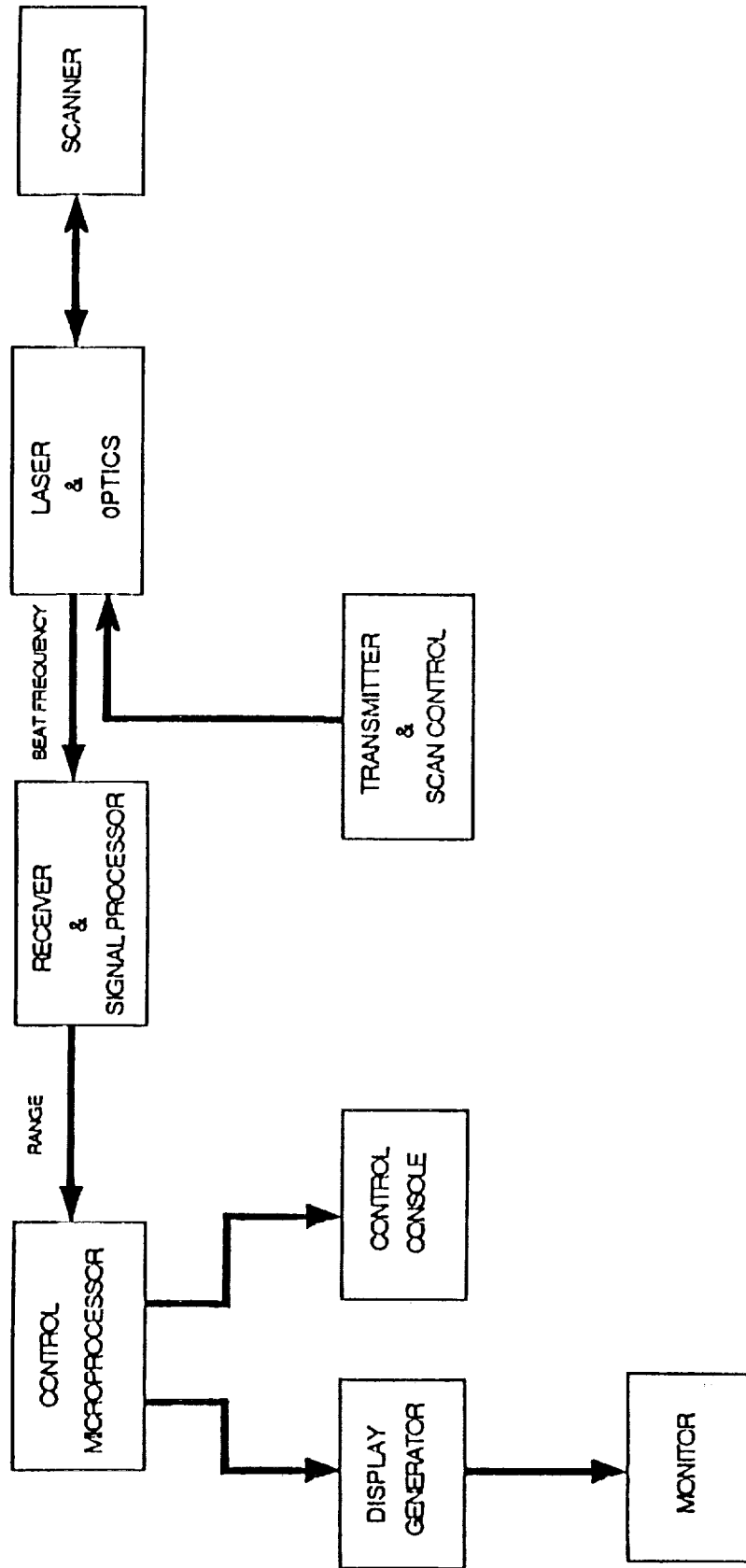

Current Problems

- Radar too large to be moved by robot
- Delicate scanning mechanism
- Doppler Effect
- Solution - Fiber Optic Based Radar

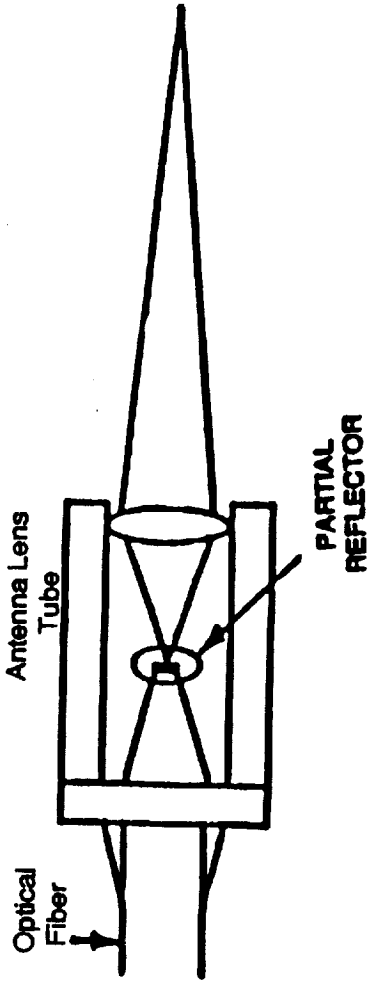

INDIVIDUAL FIBER SENSOR

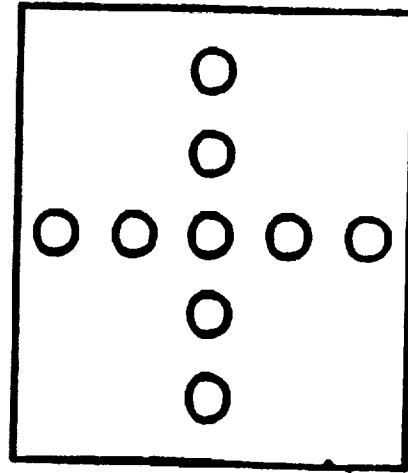

**NINE SENSOR MATRIX
(Front View)**

LASER RADAR

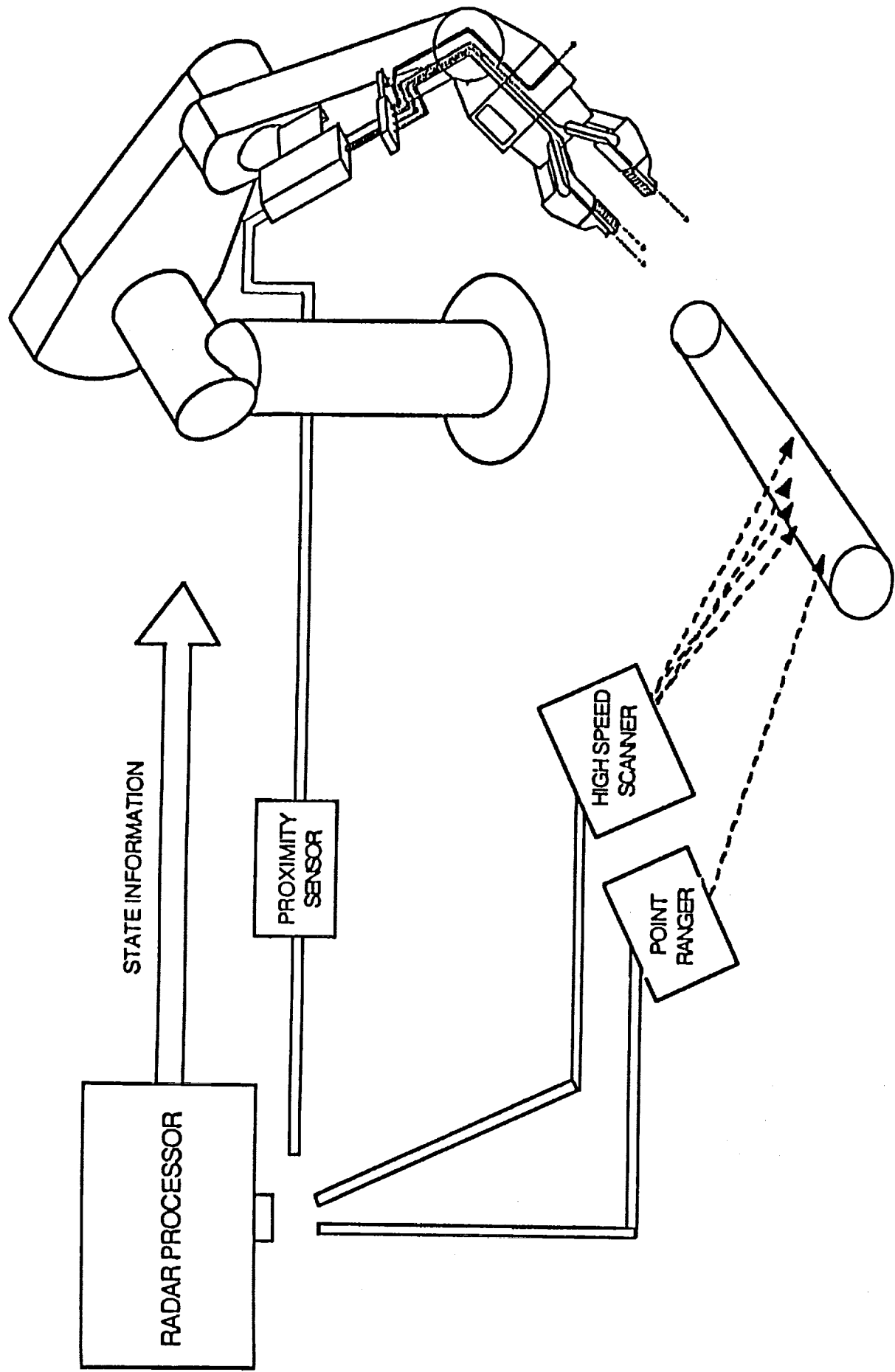

Neural Networks Modeling and Control of Dynamical Systems

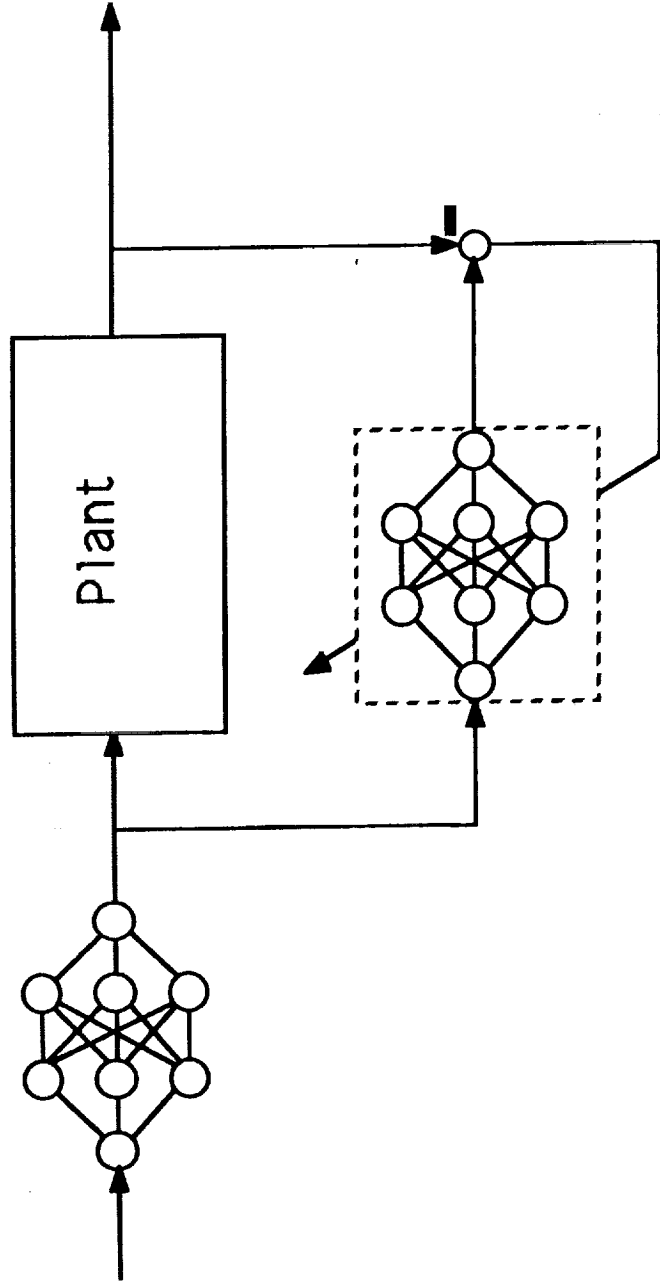

Don Soloway
Automation Technology Branch

Outline

1. Overview of Research
2. First Year Research Objectives - Started 5/91
3. Background
4. Current Work
5. Accomplishments from 5/91-9/91
6. Second Year Research Objectives

Overview

1. **Determine Nonlinear modeling capabilities**
2. **Develop and demonstrate a network controller**
3. **Implement controller in hardware for realtime use**

First Year Research Objective

- 1. Determine capabilities and limitation of neural networks as non-linear modelers**
- 2. Determine the applicability of neural networks as system controllers.**

Background

1. The initial problem
2. Overview of Neural Networks

The Problem

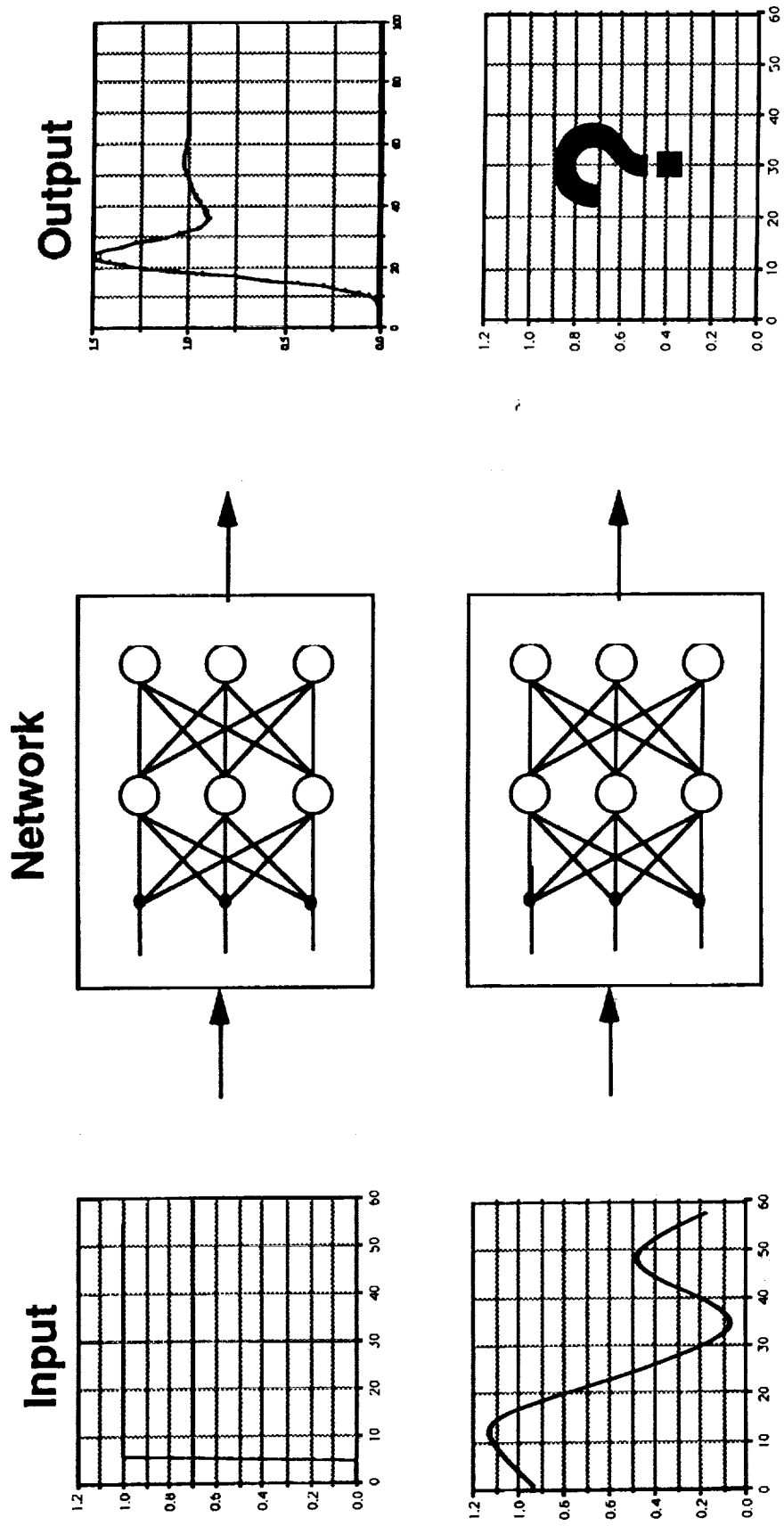

Network Architecture

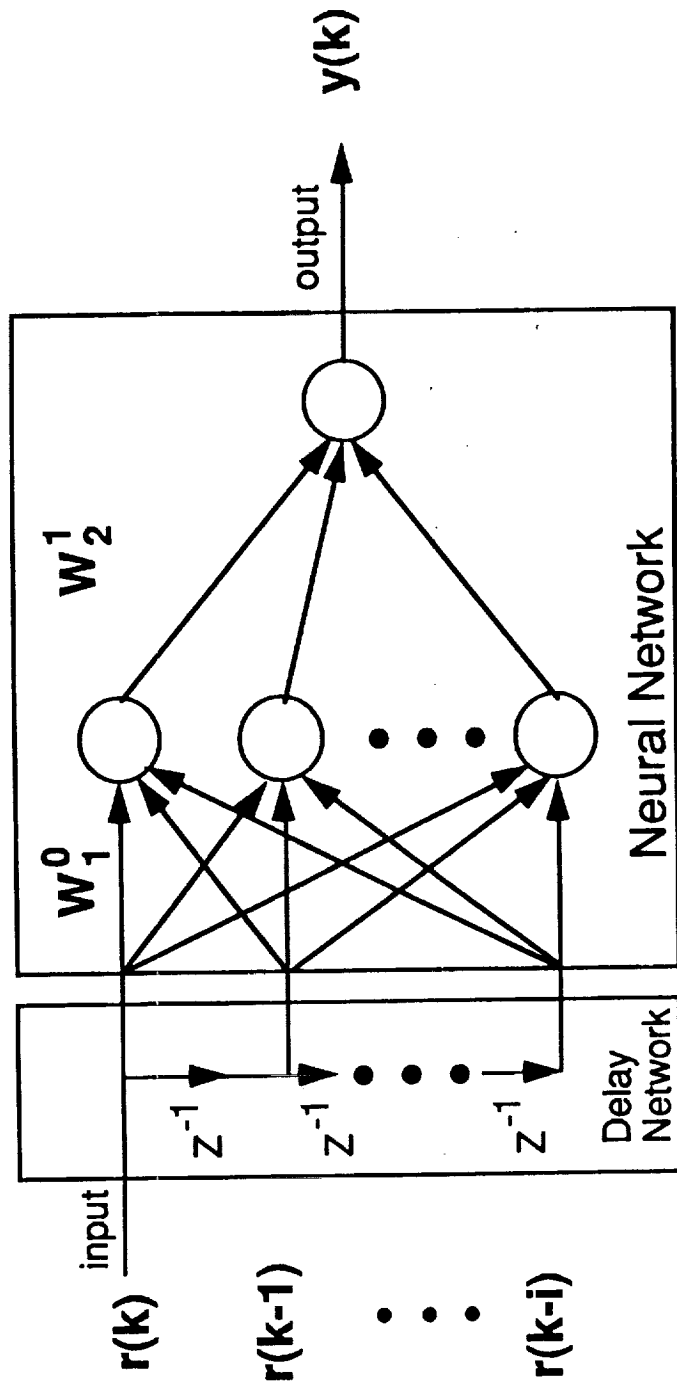

APPROACH

1. Train the network on the dynamics of a known system.
2. Analyze the learned weights and compare with the dynamic model.

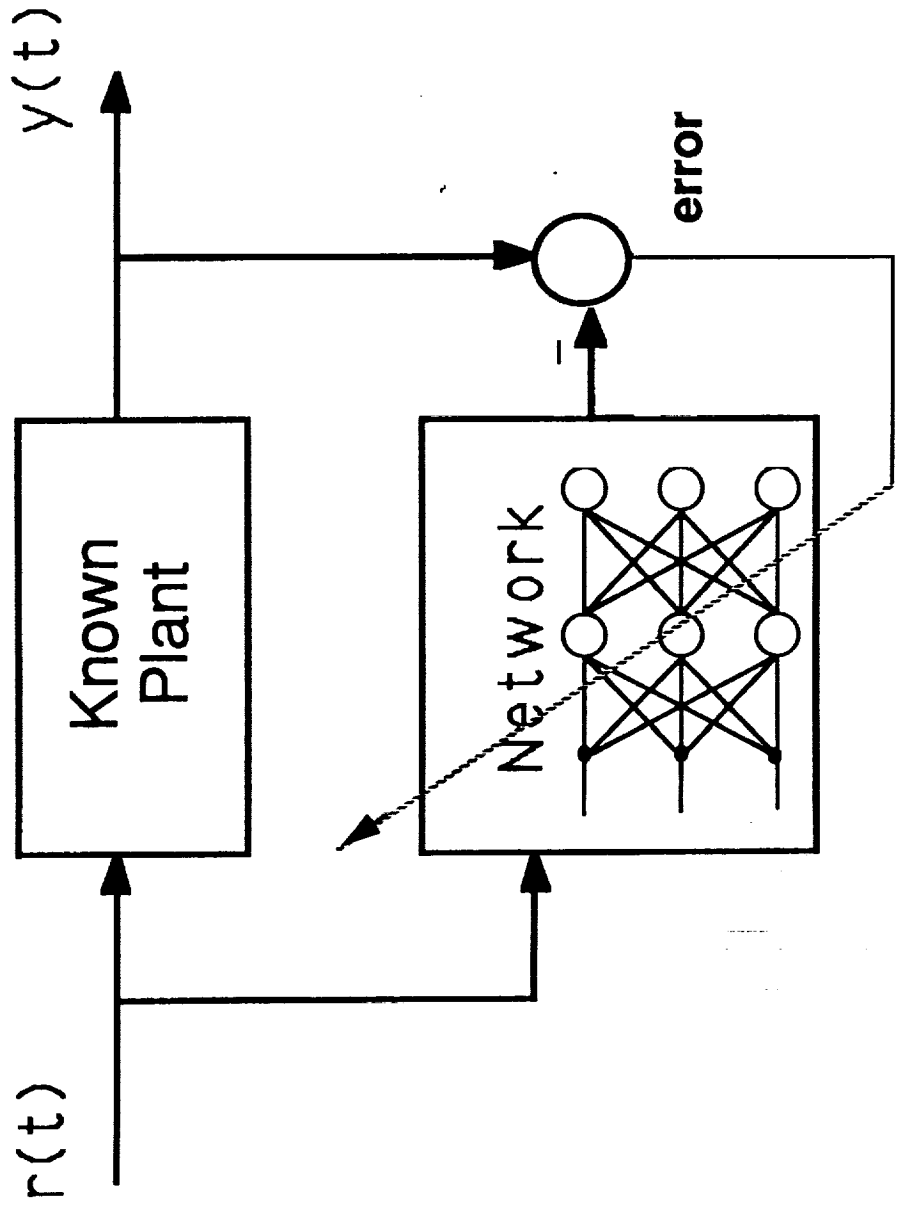

Step Response of Network

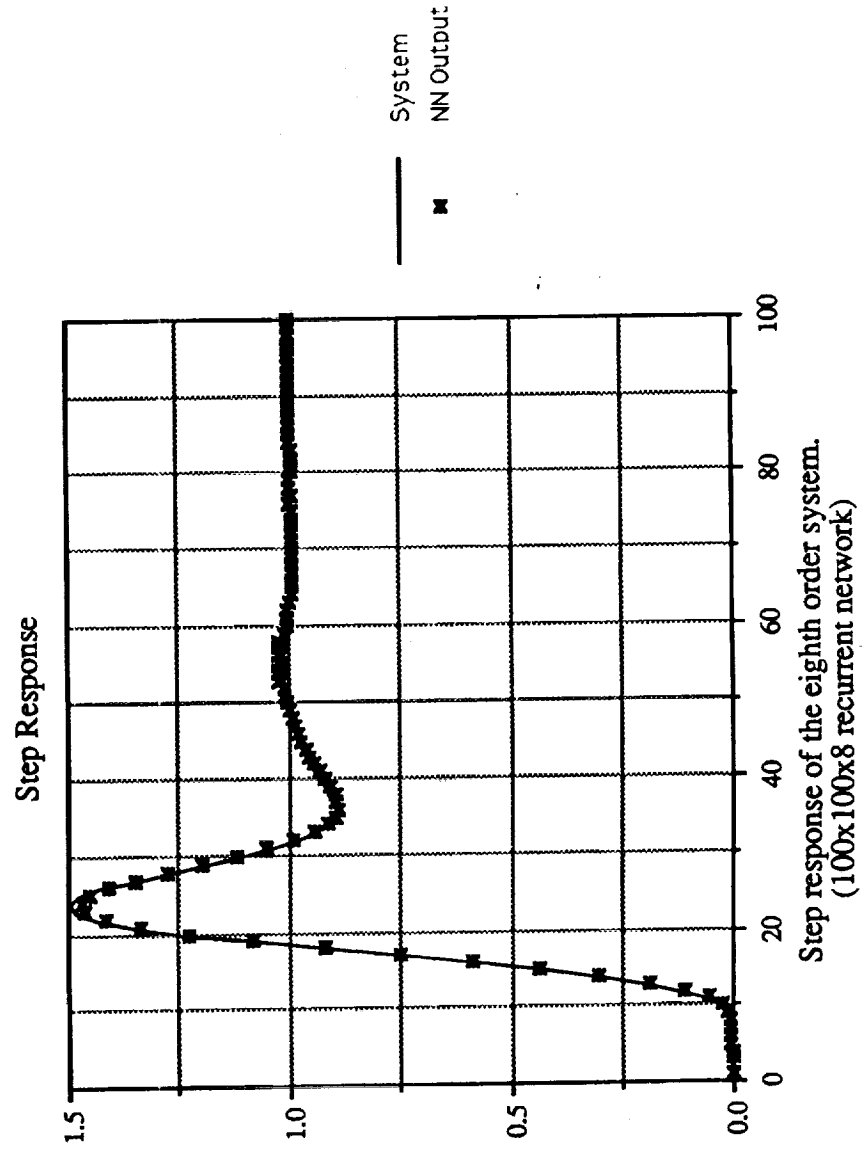

Analysis

Linear System

$$y(k) = (h(0) + h(1) z^{-1} + \dots + h(N) z^{-N}) r(k)$$

Let us define the operator Z^{-1}

$$Z^{-1} r(k) = [r(k) \quad r(k-1) \quad \dots \quad r(k-N)]$$

So

$$y(k) = [h(0) \quad h(1) \quad \dots \quad h(N)] [Z^{-1} r(k)]$$

Neural Network

Let us assume linear node, then

$$y(k) = W_2^0 [Z^{-1} r(k)]$$

where

$$W_2^0 = W_1^0 W_2^1$$

so

$$[h(0) \quad h(1) \quad \dots \quad h(N)] = W_2^0$$

Impulse Response

After being trained on a step response.

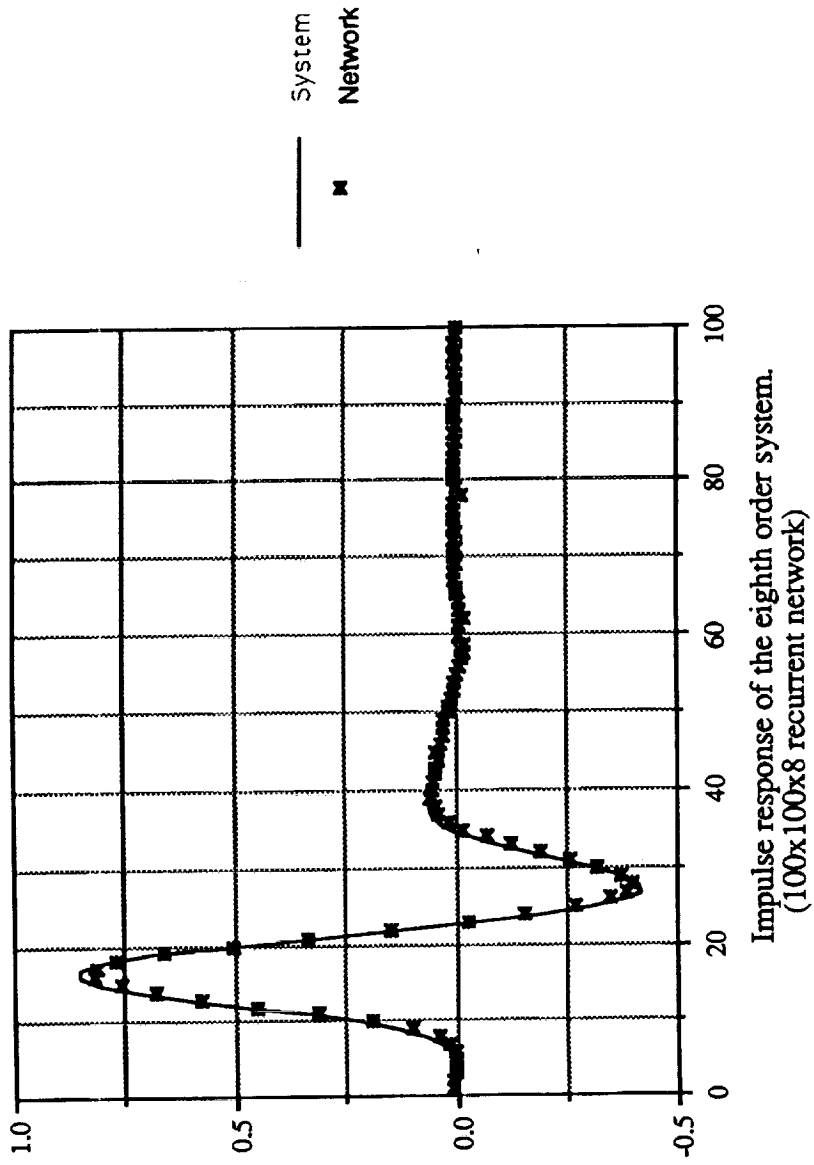

Extending The Work to Non-linear

We have shown for a linear dynamical system

$$\dot{y}(t) = f(t, y(t), u(t)) \quad , \quad y(t) = \int h(\tau) u(t-\tau) d\tau$$

where y is the state vector

$f(\cdot)$ is the dynamical system

$h(t)$ is the impulse

$u(t)$ is the input

That $h(t)$ can be extracted out of the neural network.

If the system f is non-linear and analytic, then

The general solution is

$$y(t) = \int h(\tau) u(t-\tau) d\tau + \iint h(\tau_1, \tau_2) u(t-\tau_1) u(t-\tau_2) d\tau_1 d\tau_2 + \iiint h(\tau_1, \tau_2, \tau_3) u(t-\tau_1) u(t-\tau_2) u(t-\tau_3) d\tau_1 d\tau_2 d\tau_3 \dots$$

Discrete Volterra Series

$$y(t) = \int h_1(t) x(t-\tau) d\tau + \iint h_2(\tau_1, \tau_2) x(t-\tau_1) x(t-\tau_2) d\tau_1 d\tau_2 + \dots$$

Discreteizing we get

$$y(k) = \sum_n h_1(n) x(k-n) + \sum_{n_1} \sum_{n_2} h_2(n_1, n_2) x(k-n_1) x(k-n_2) + \dots$$

Where h_1 is a one dimensional finite impulse response
and h_2 is a two dimensional finite impulse response.

Neural Networks and Volterra Series

We have shown that by taking the Taylor expansion of the neural network equations and matching the terms in the Volterra series we get:

$$h_1(k) = \sum_j W_j W_{j,k} (1 - \tanh^2(b_j))$$

$$h_2(k,l) = \sum_j W_j W_{j,k} W_{j,l} (2 \tanh(b_j) - 2 \tanh^3(b_j))$$

$$h_3(k,l,m) = \sum_j W_j W_{j,k} W_{j,l} W_{j,m} (-2 + 8 \tanh(b_j) - 6 \tanh^3(b_j))$$

Where W_j is the weight from the internal node to the output node.

$W_{j,k}$ is the weight from the k input node to the j internal node.

b_j is the bias on the j hidden node.

Example

Imperfect Square - Law Device

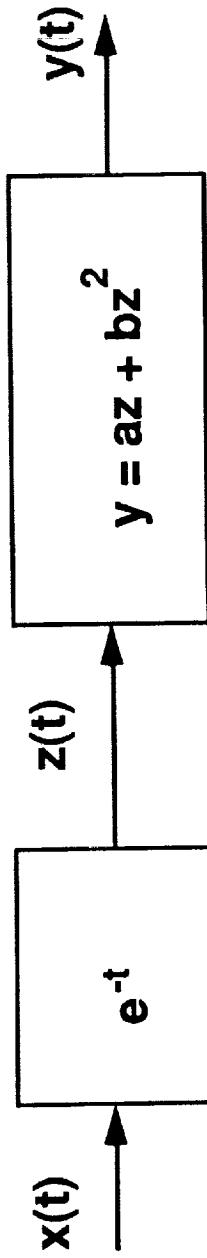

$$y(t) = f(t, x(t))$$

The solution is

$$h_1(t_1) = ae^{-t_1}$$

$$\text{and } h_2(t_1, t_2) = be^{-(t_1+t_2)}$$

Results

$$h_2(\tau_1, \tau_2) = 0.04 e^{-(\tau_1 + \tau_2)} \sum_j W_j W_{j, \tau_1} W_{j, \tau_2} (2 \tanh^3(b_j) - 2 \tanh(b_j))$$

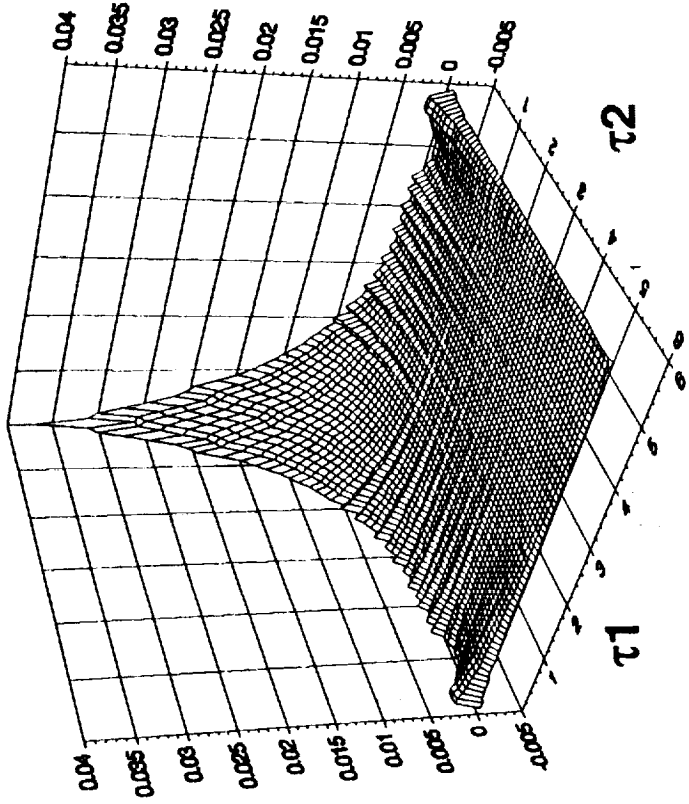
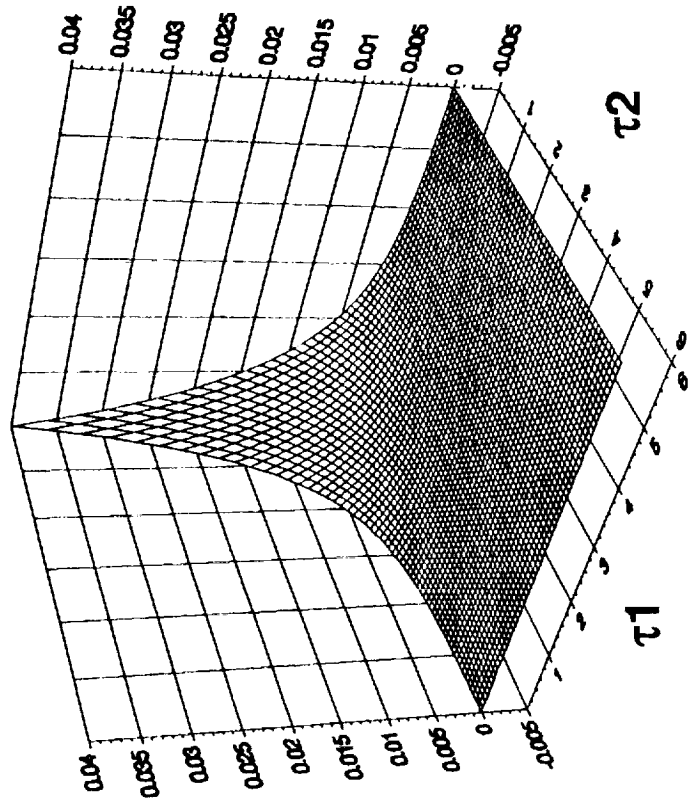

Accomplishments

In First Five Months 5/91 - 9/91

- 1. Analyzed analytic nonlinear systems with neural networks**
- 2. Found analytical approach to the modelling**
- 3. Extended linear theory to nonlinear theory**
Generating two publications
 - 1. Submitting to the IEEE Conference on Intelligent control**
 - 2. Submitting to the International Journal of Neural Networks**
- 4. Began beta testing of neural network control code.**

Objectives for the Next Year

1. Finish Volterra series analysis
2. Investigate capabilities and limitations of a Neural Network with feedback.
(this configuration should allows the neural network to learn models that the volterra series cannot model)
3. Start Investigating the Neural Network as a Controller
4. Develop neural network hardware

Adaptive Artificial Neural Network for Autonomous Robot Control*

Michael K. Arras, Peter W. Protzel, Daniel L. Palumbo

**Institute for Computer Applications in Science
and Engineering (ICASE)
NASA Langley Research Center, Hampton, Virginia**

N 9 2 - 2 7 7 7 0

* This research was supported by the National Aeronautics and Space Administration under NASA Contract No. NAS1-18605.

Neural Network Controller for Robot Arm Positioning with Visual Feedback

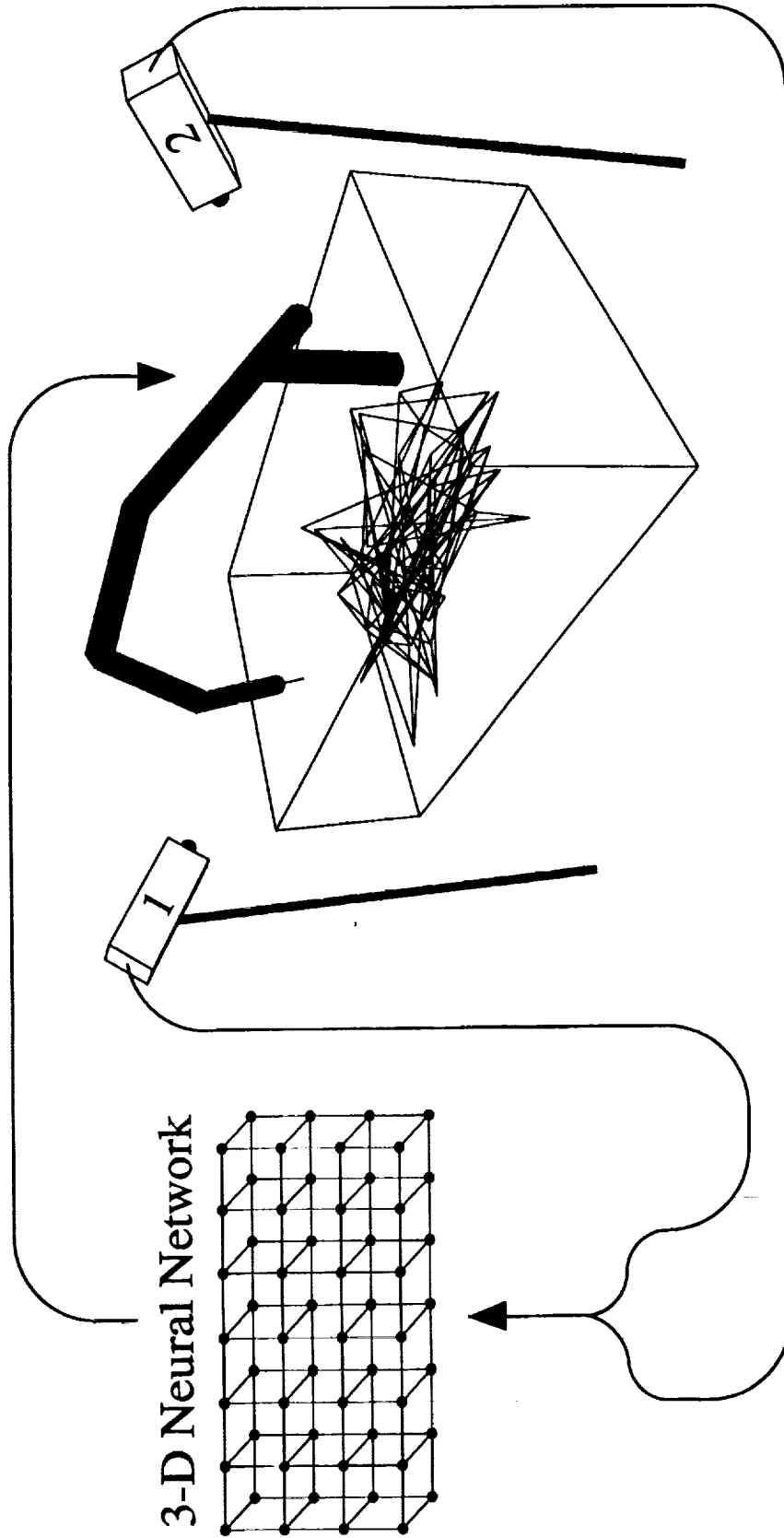

Initial State of the Network

View from both Cameras

Camera 1

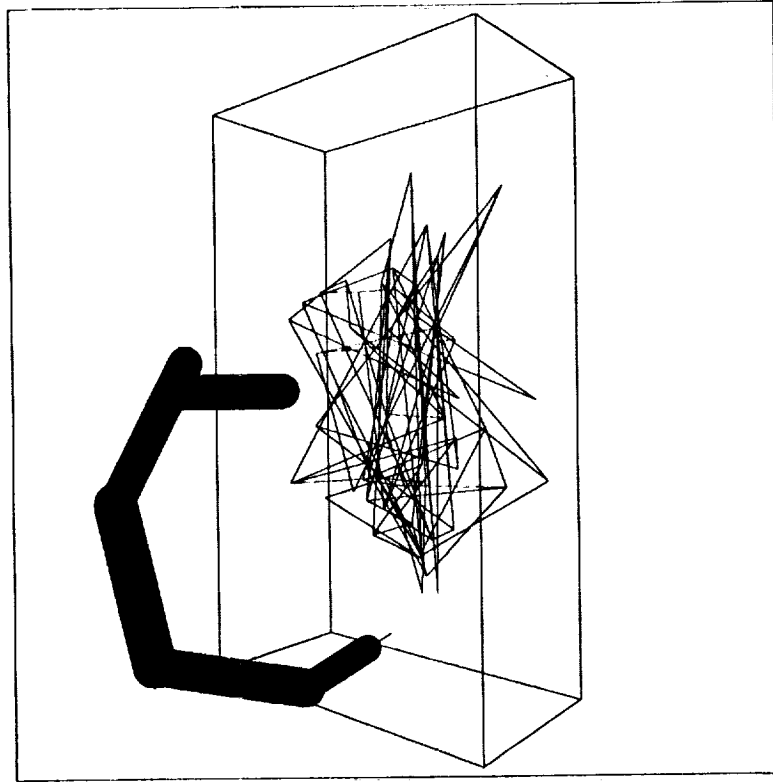

Camera 2

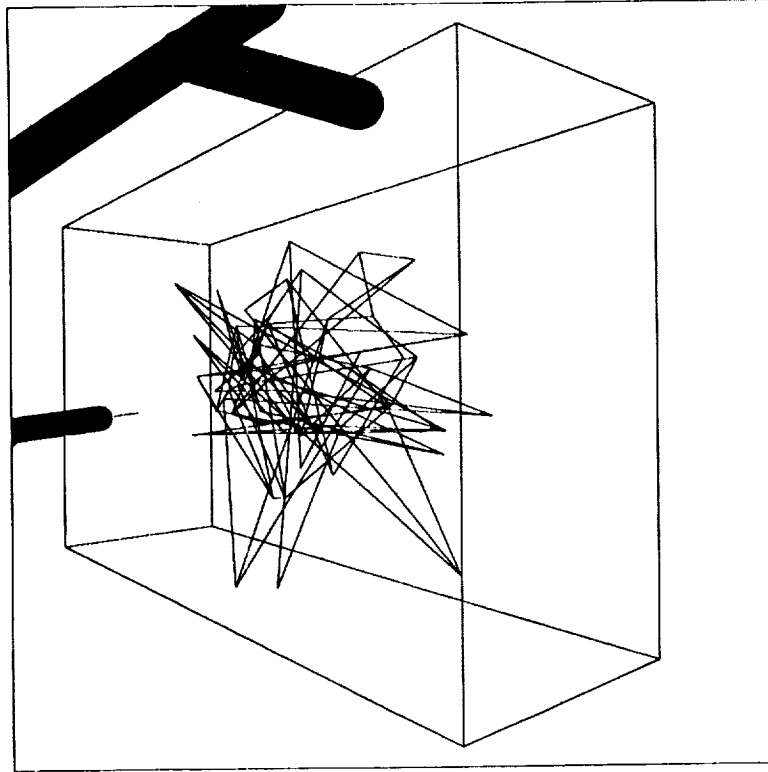

Initial State of the Network

Neural Network Controller for Robot Arm Positioning with Visual Feedback

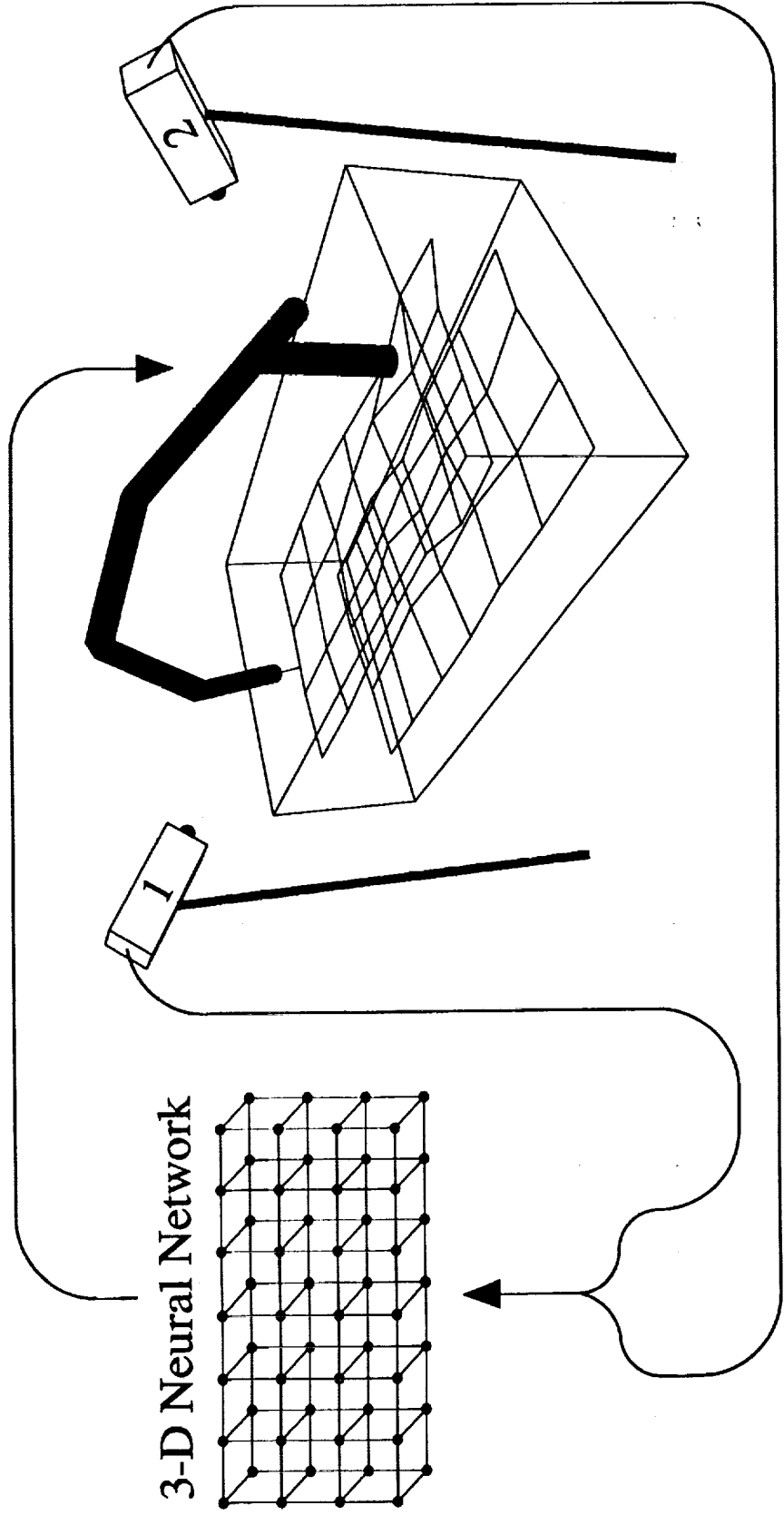

State of the Network After Training

Initial Training of the Arm

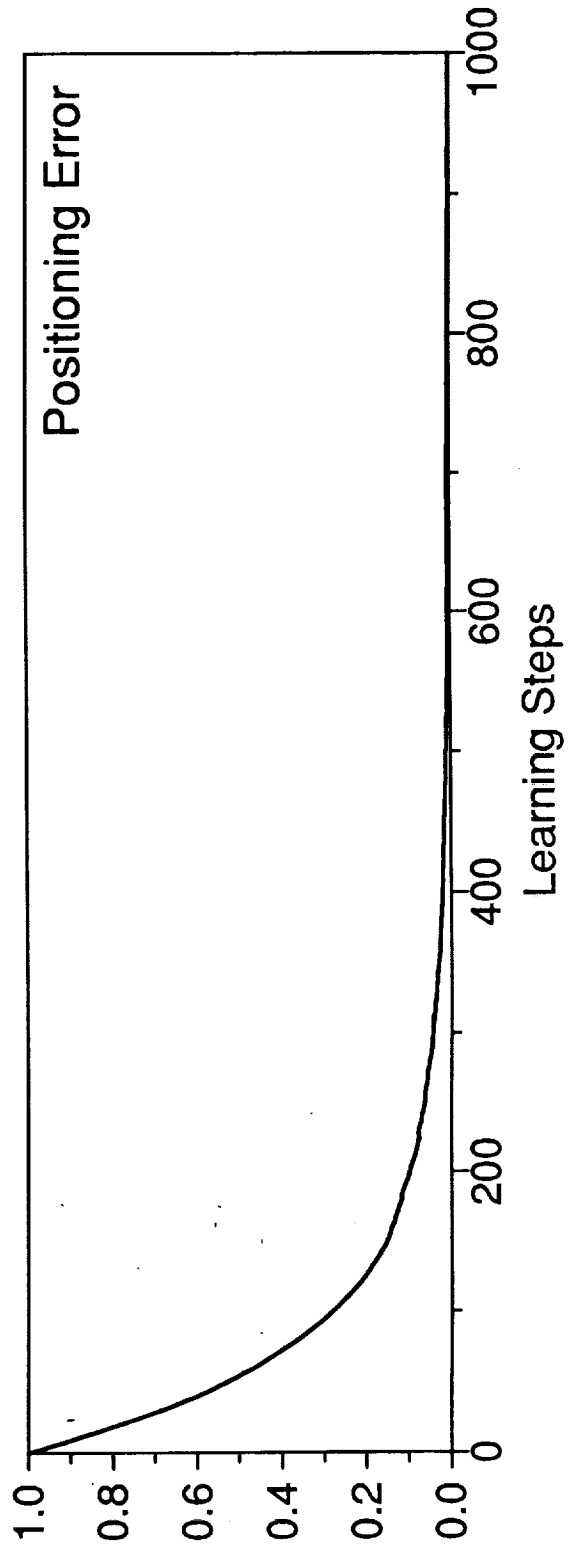
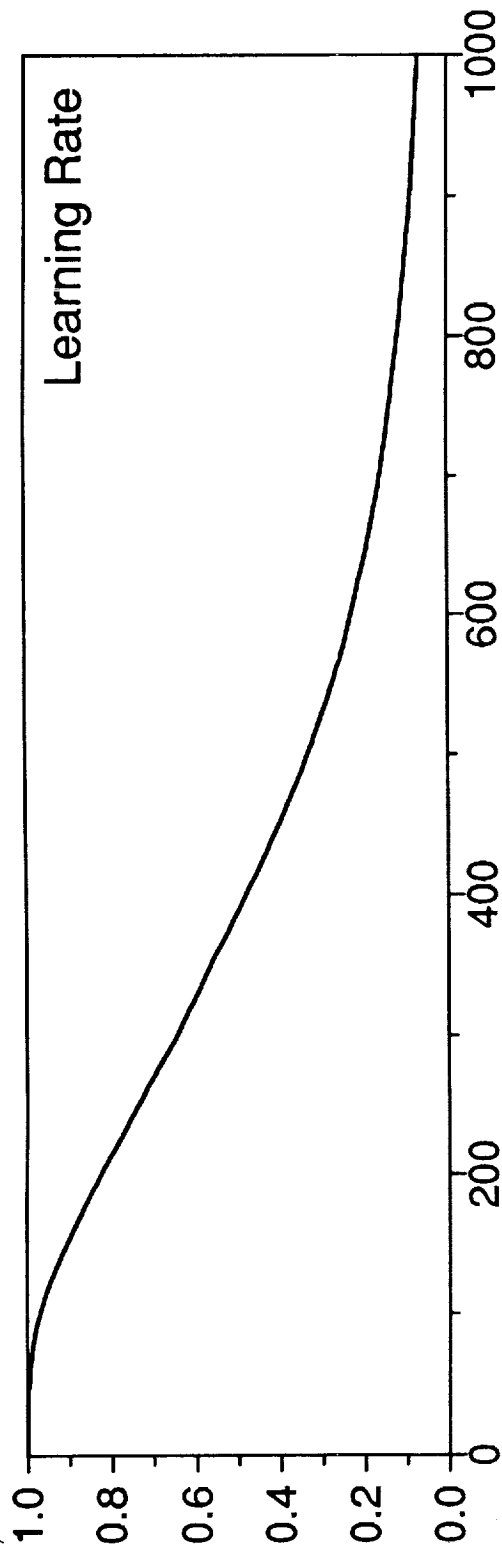

Automatic Recovery From Cumulative Fault-Scenarios

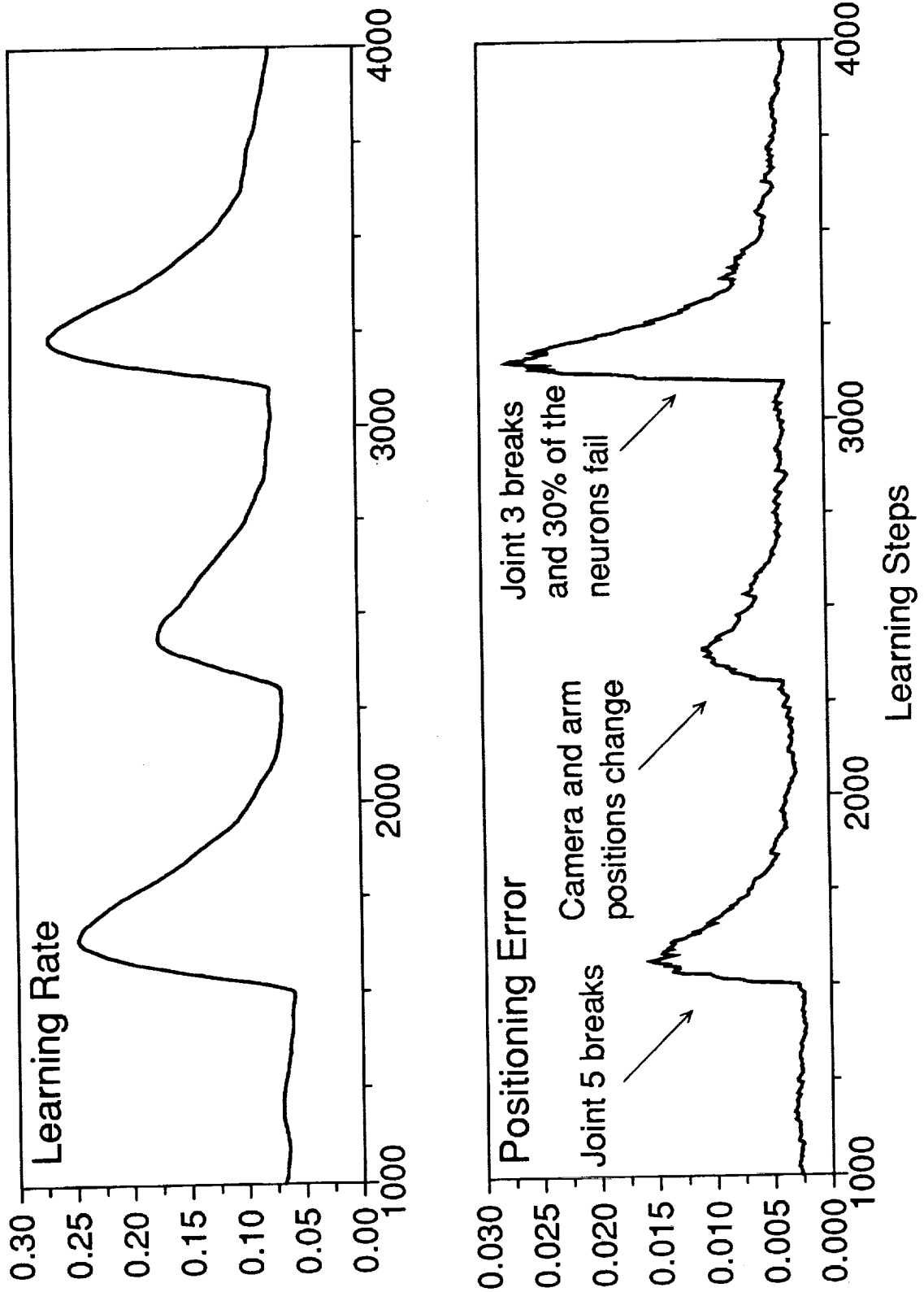

Error Reduction by Iterative Fine Movements

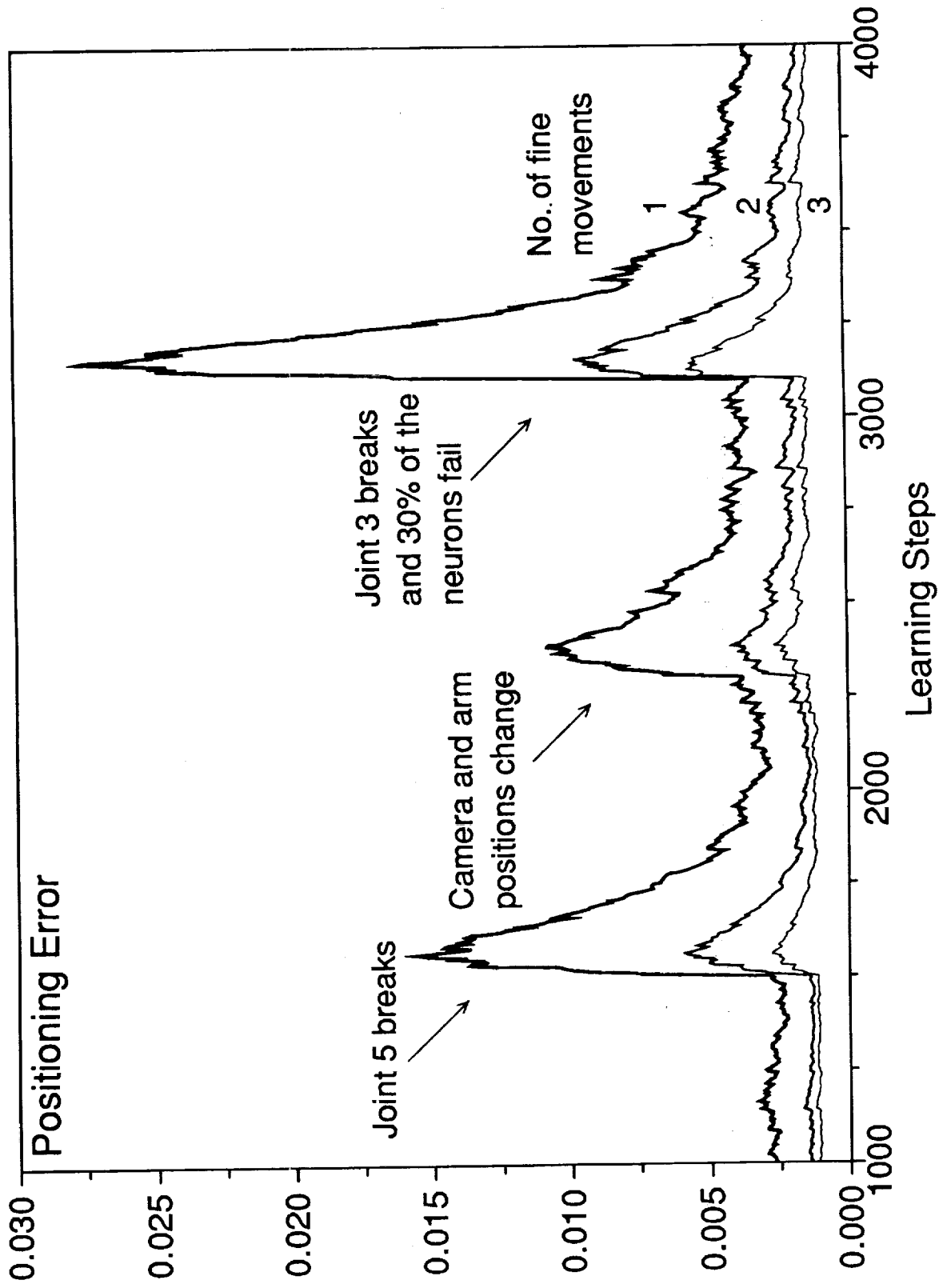

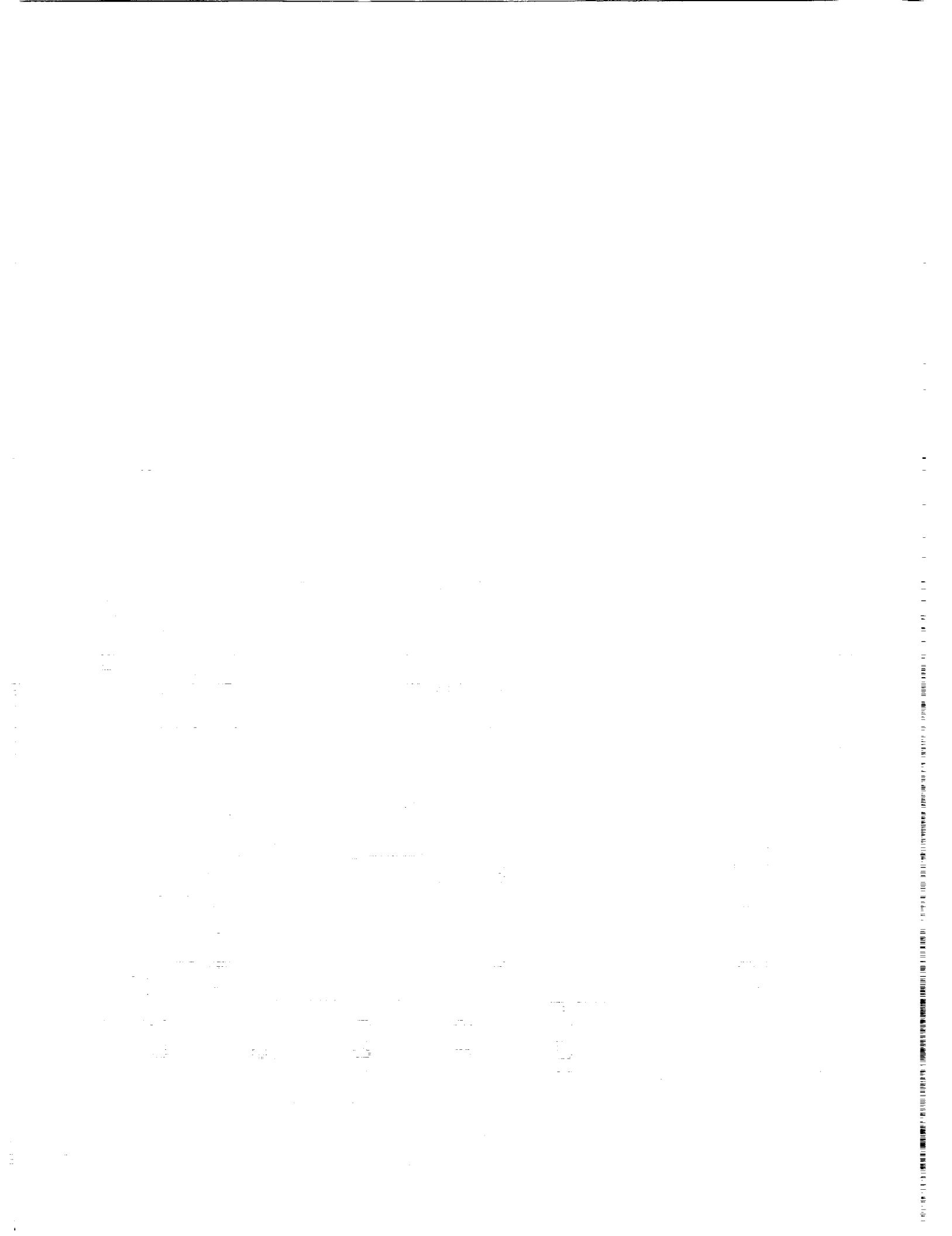

RMS ACTIVE DAMPING AUGMENTATION

**Michael G. Gilbert
Michael A. Scott
Martha E. Demeo**

**Langley Workshop on Automation and
Robotics for Space-Based Systems**

December 10, 1991

N92-27771

RMS ACTIVE DAMPING AUGMENTATION

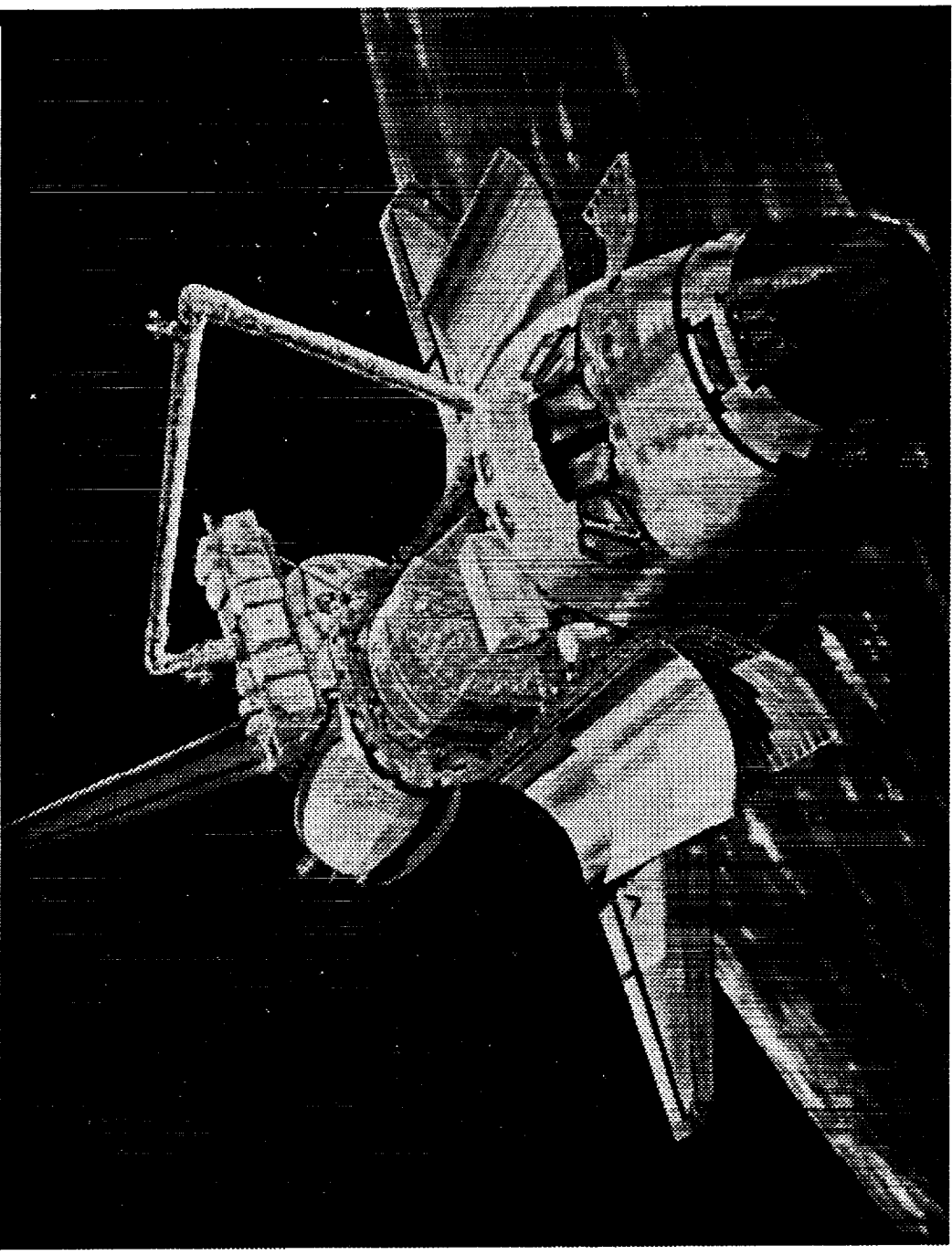

... ..

POTENTIAL SPACE STATION ASSEMBLY BENEFITS DUE TO CSI (Timeline)

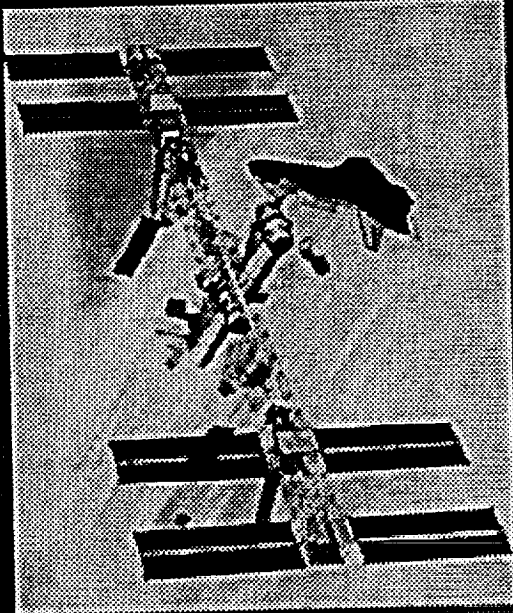

Draper RMS Simulator response
Payload 3500 lbs

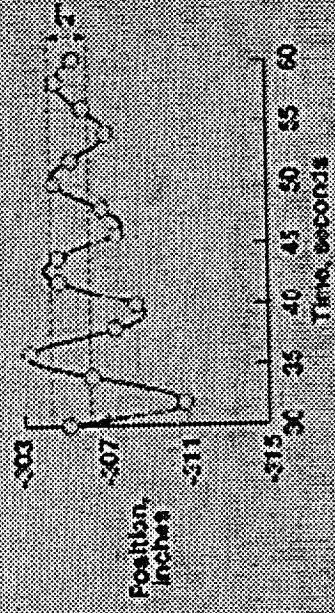

RMS settling time



Potential CSI benefits

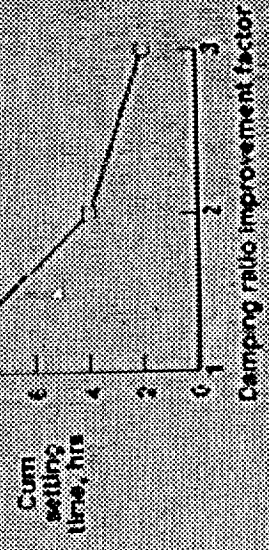

LaRC / JSC BRIDGE PROGRAM

TASK 1: Determine active damping control feasibility using existing hardware

TASK 2: Active damping controller design with (minimum) hardware changes

TASK 3: Ground evaluation of active damping control

TASK 4: Flight Demonstration

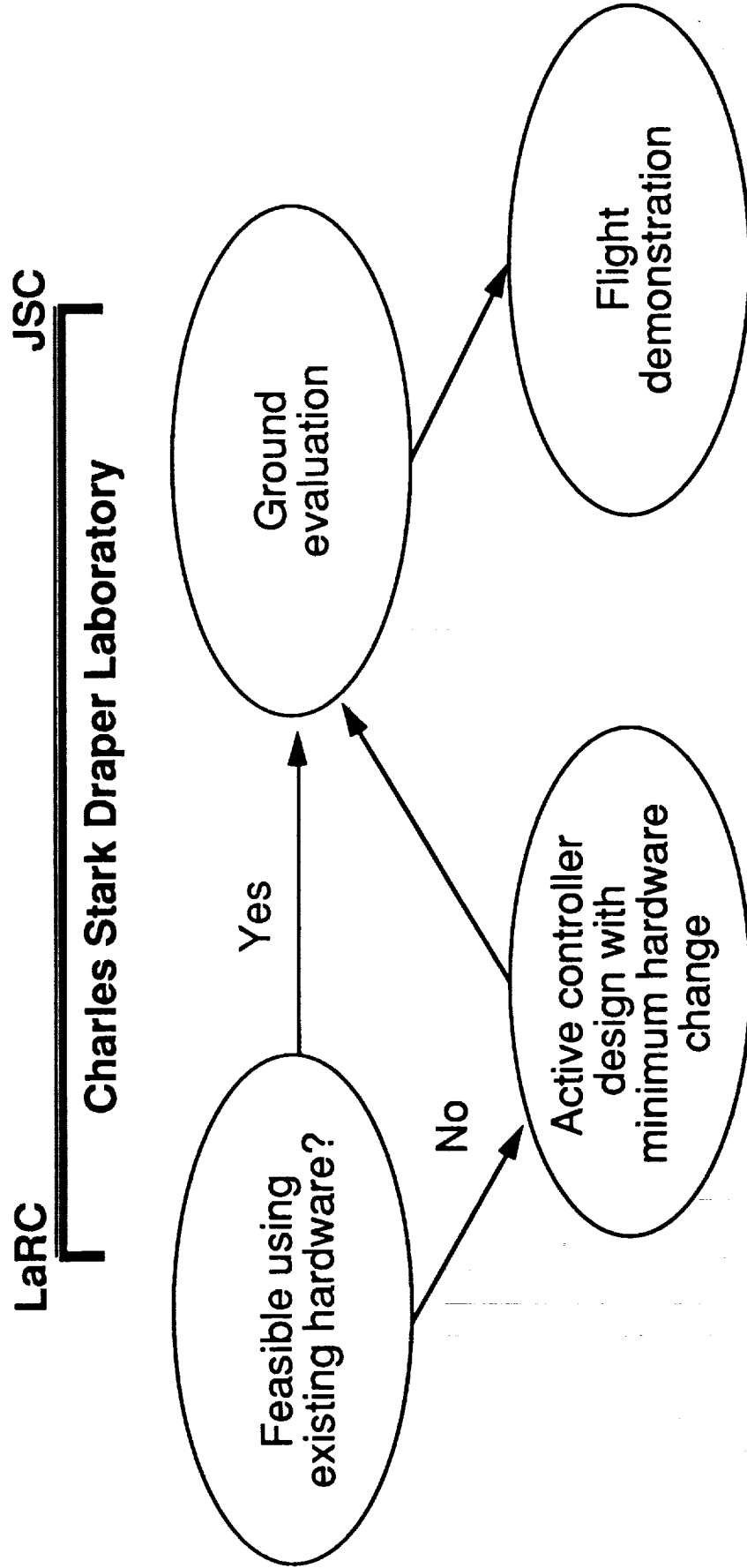

OUTLINE

Introduction

Analytical Accomplishments

Initiation of Man-in-the-Loop Simulations

Schedule

Concluding Remarks

CONTROL LAW DESIGN PROCESS

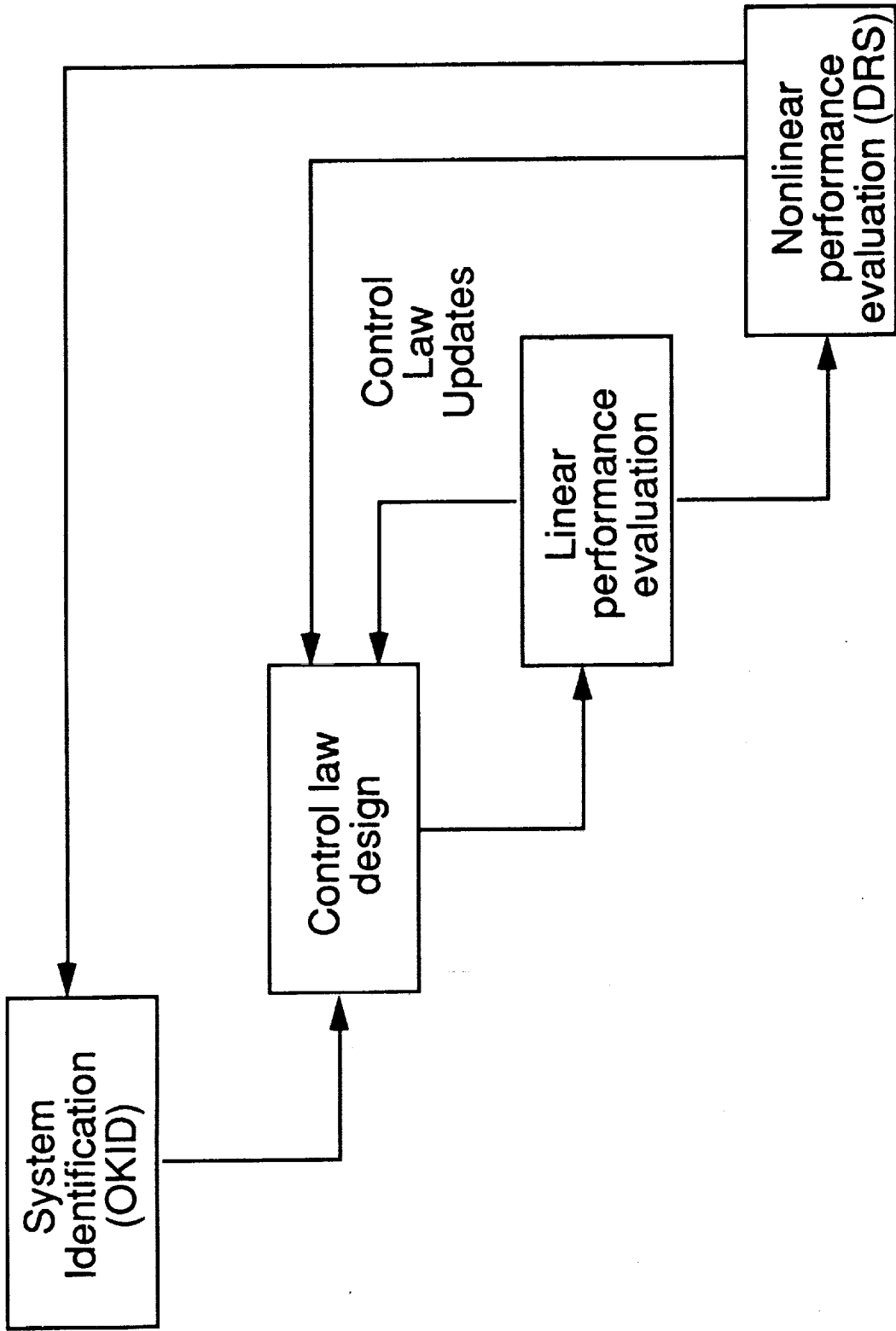

DRAPER RMS SIMULATOR

Baseline Simulation

- Includes flexibility of booms, joint housings, grapple, and orbiter sidewall
- Simulation of RMS operation software in orbiter GPC
- Models nonlinear gearbox effects, friction and stiction, time delays
- Includes joint encoders, tachometers, joint motors and servos

External Input Simulation

- Allows arbitrary external joint rate command inputs for Sys ID

CSI Controller Simulation

- Added 3-axis acceleration at tip, tachometer, and encoder feedback
- Digital dynamic compensator structure
- CSI controller implementation logic

MIMO ACCELERATION CONTROL LAWS IMPROVE DAMPING

Frequency and Damping Comparisons

RMS Position	Open-Loop		Closed-Loop	
	ω (hz)	ζ (%)	ω (hz)	ζ (%)
1	0.18	0.12	0.19	0.25
2	0.17	0.09	0.18	0.28
3	0.14	0.13	0.15	0.38

(Results using SPAS payload accelerometer model)

POTENTIAL LOAD REDUCTION BENEFIT IDENTIFIED

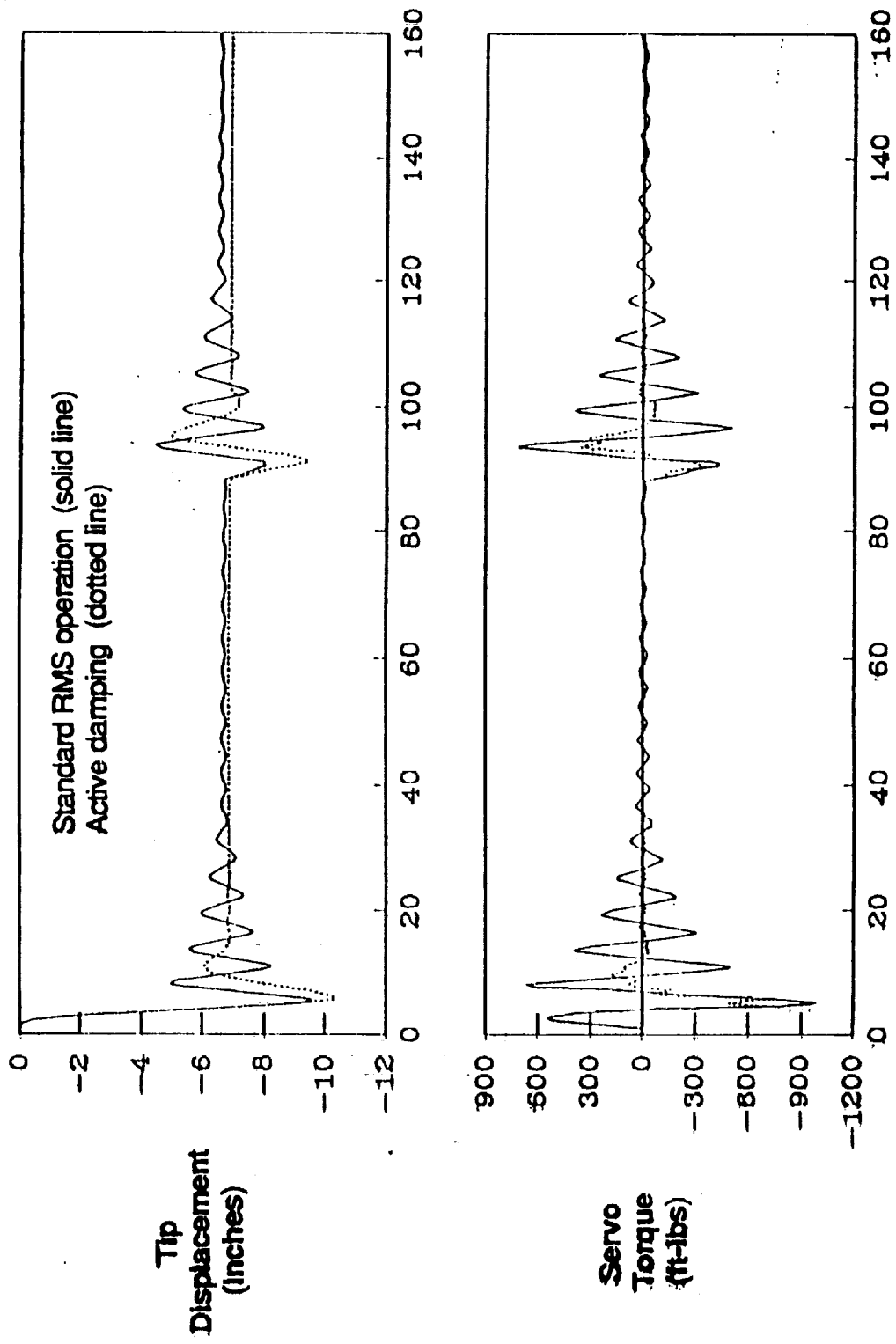

DRS MODIFIED TO MODEL DISTRIBUTED ACCELERATIONS

CSDL formulated accelerometer equations

- Two mid-boom and three link end locations
- Three axis accelerations at each location
- Full accounting of interbody forces and nonlinear motions

CSDL modified DRS delivered

- Optional inclusion of omega-cross terms
- Calculations validated by CSDL and LaRC

Used to define feedback acceleration locations

ACCELEROMETER LOCATION DEFINED

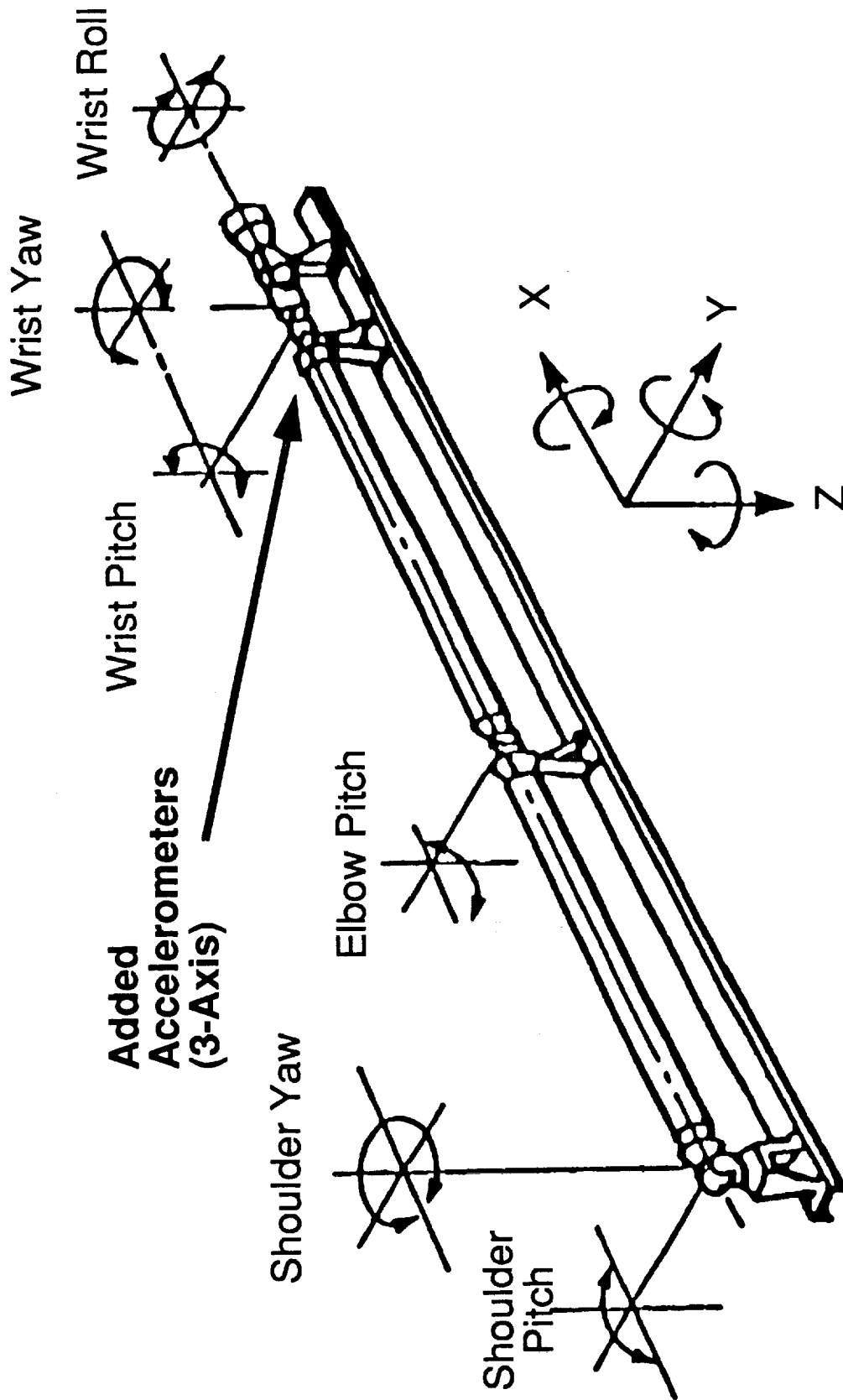

OUTLINE

Introduction

Analytical Accomplishments

Initiation of Man-in-the-Loop Simulations

Schedule

Concluding Remarks

SHUTTLE AFT COCKPIT SIMULATOR

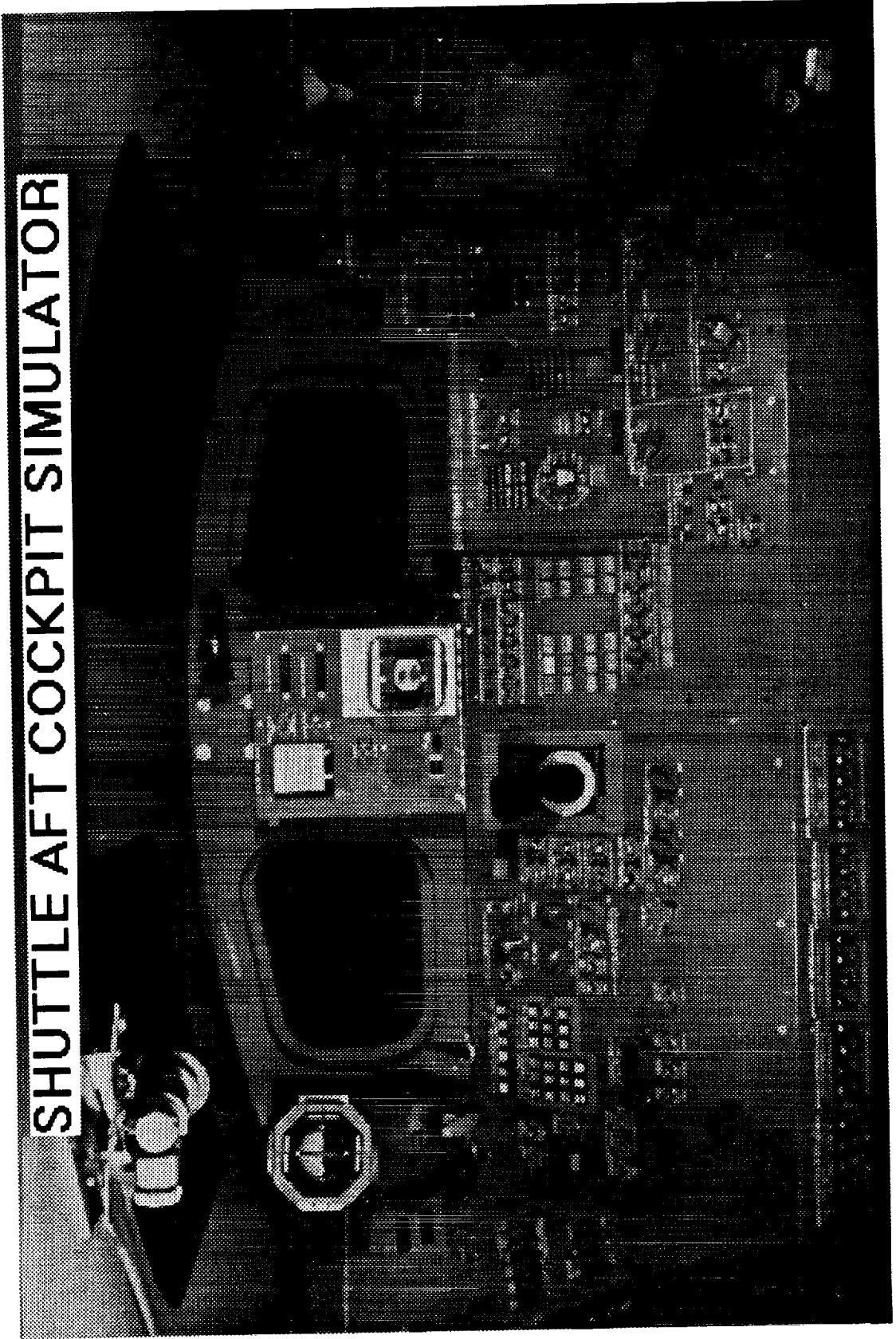

SES TEST GOALS AND OBJECTIVES

Goal:

Obtain quantitative and qualitative SES data supporting advocacy of RMS active damping augmentation flight demonstration

Objectives:

- Measurable reductions in RMS vibration decay time
- Quantitative reductions in predicted RMS loads due to payload handling and Shuttle FCS thruster firings
- No adverse Shuttle FCS interaction
- Qualitative performance improvements defined by trained RMS operators (flight crew members)

SES MODIFICATIONS TO SUPPORT RMS ACTIVE DAMPING AUGMENTATION

Arm dynamics simulation (Phase 1):

- Calculation of arm accelerations at limited locations
- Damping model for flexible booms
- Off-line structural loads analysis capability

Flight software simulation (Phase 2):

- Implementation of active damping controller concept
 - Acceleration feedback signals
 - Damping joint rate commands added to position hold
 - Maximum 36th order controller
 - Gain scheduling (Phase 2b)
- Operational logic and interfaces to RMS and FCS software

Activities	1991												1992											
	S	O	N	D	J	F	M	A	M	J	J	A	S	O	N	D								
SES Interfaces																								
Requirements Document																								
Test Plan																								
Meetings																								
Phase 1 - Accelerometer Simulation																								
Formulation Delivery																								
Simulation Development																								
JSC Validation																								
Engineering Study																								
Phase 2a - Point Design Controller																								
Control CR Delivery																								
Simulation Development																								
JSC Validation																								
Engineering Study																								
Phase 2b - Gain Scheduled Controller																								
Modified Control CR Delivery																								
Simulation Development																								
JSC Validation																								
Engineering Study																								
Final Report																								

Legend:
 Red - Planned
 Blue - Accomplished
 Green - SES Testing

CONCLUDING REMARKS

Analysis and control law design work progressing:

- Applying advanced system identification methods (OKID)
- MIMO control laws and implementation logic
- Accelerometer calculations have been added to the non-real time simulation code
- Potential RMS loads reduction benefit from active damping

Man-in-the-loop simulation effort has been initiated:

- Working with JSC to use the Systems Engineering Simulator
- Requirements document near signature
- Engineering assessment of accelerations scheduled for April 1992
- Active Damping Augmentation testing in June and August 1992

A SPACE CRANE CONCEPT FOR PERFORMING ON-ORBIT ASSEMBLY

**JOHN T. DORSEY
SPACECRAFT STRUCTURES BRANCH**

**PRESENTED AT:
1991 NASA Langley Workshop on Automation and
Robotics for Space-based Systems**

December 10, 1991

N 9 2 - 2 7 7 7 2

BRIEFING OUTLINE

- WHY IS IN-SPACE CONSTRUCTION NEEDED?
- SPACE CRANE CONCEPT
- CONCLUDING REMARKS

IN-SPACE ASSEMBLY AND CONSTRUCTION ENHANCES FUTURE MISSIONS PLANNING FLEXIBILITY

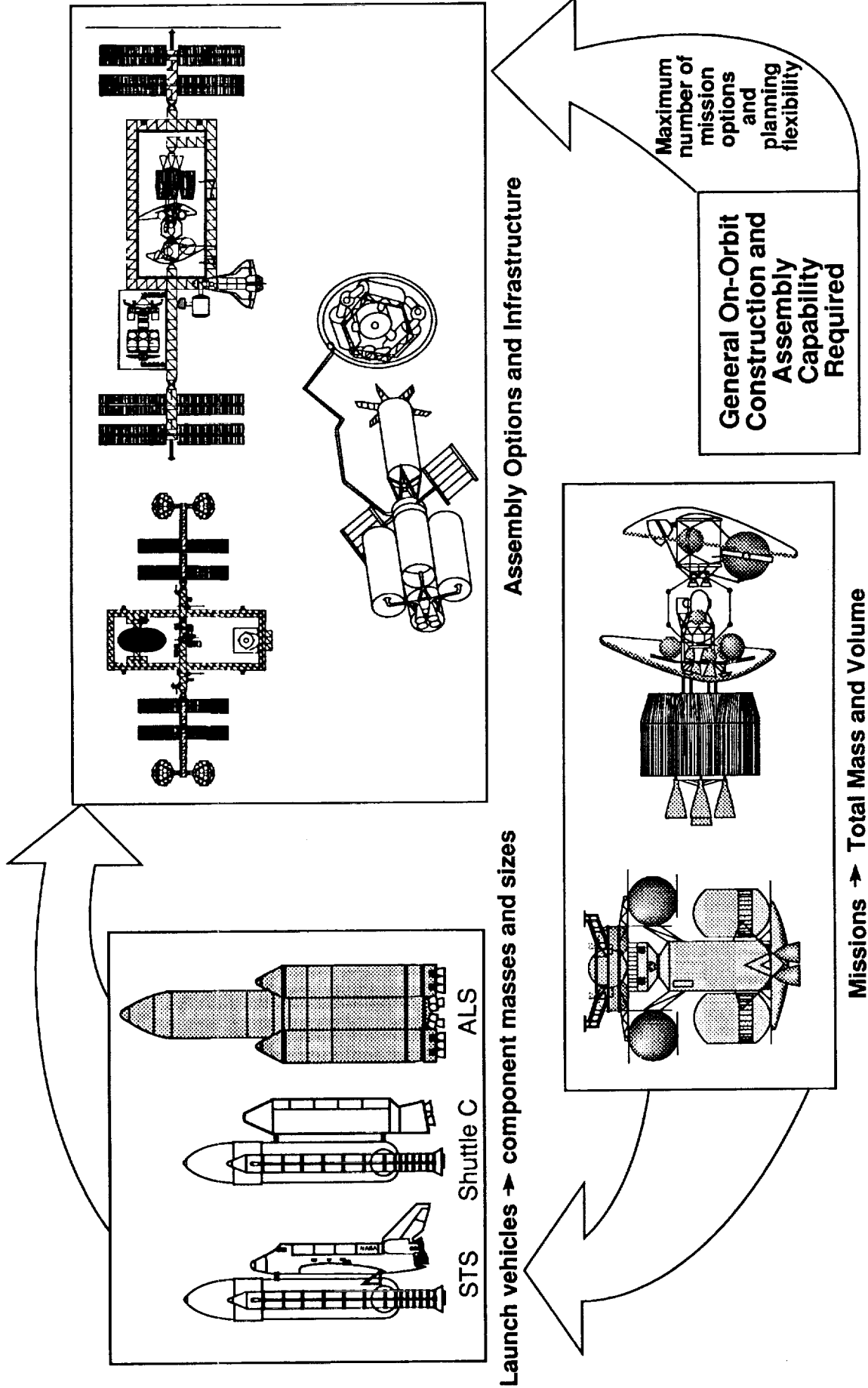

IN-SPACE ASSEMBLY AND CONSTRUCTION FACILITY CONCEPT

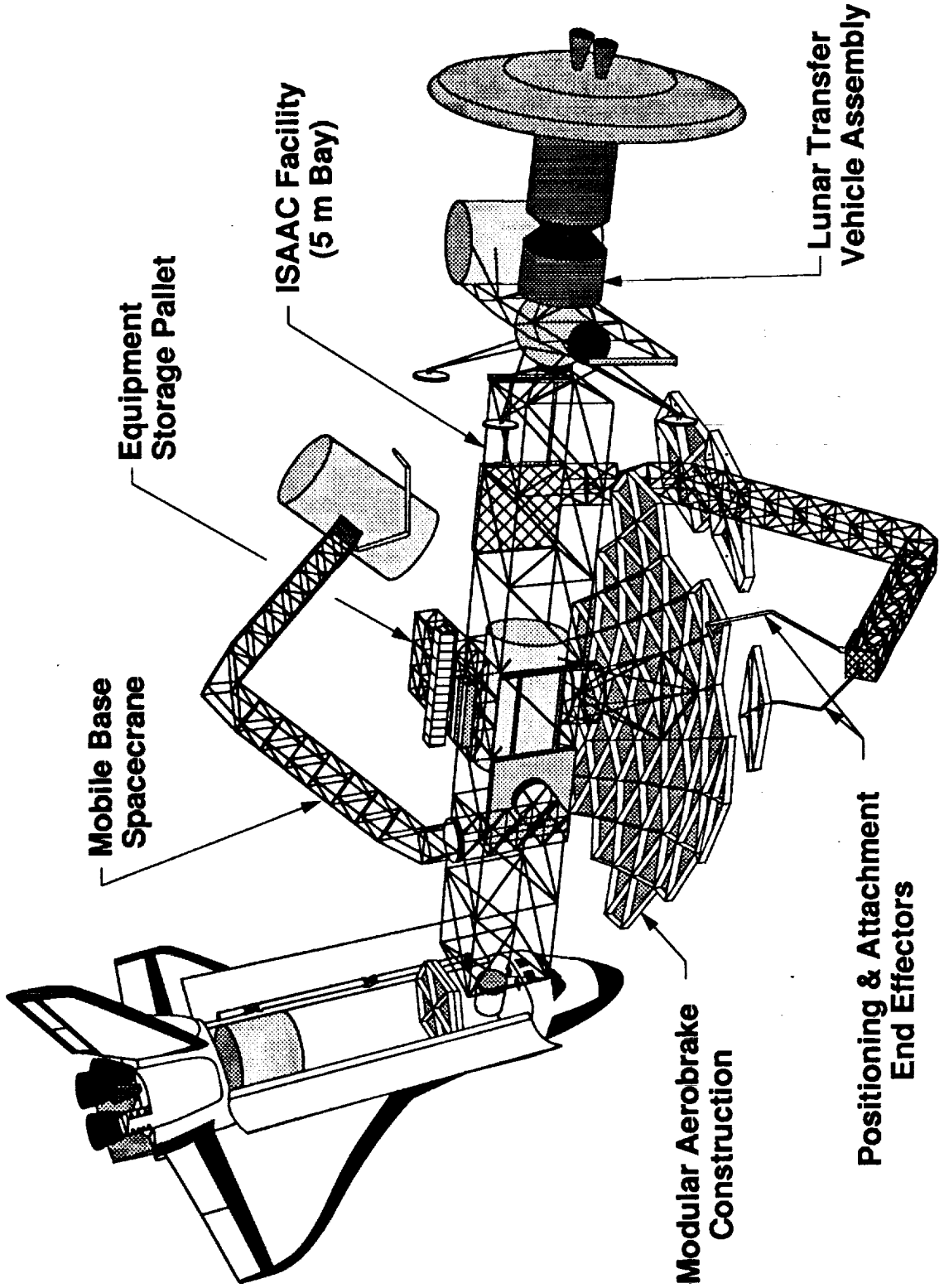

SPACE CRANE CONCEPT WITH MOBILE BASE

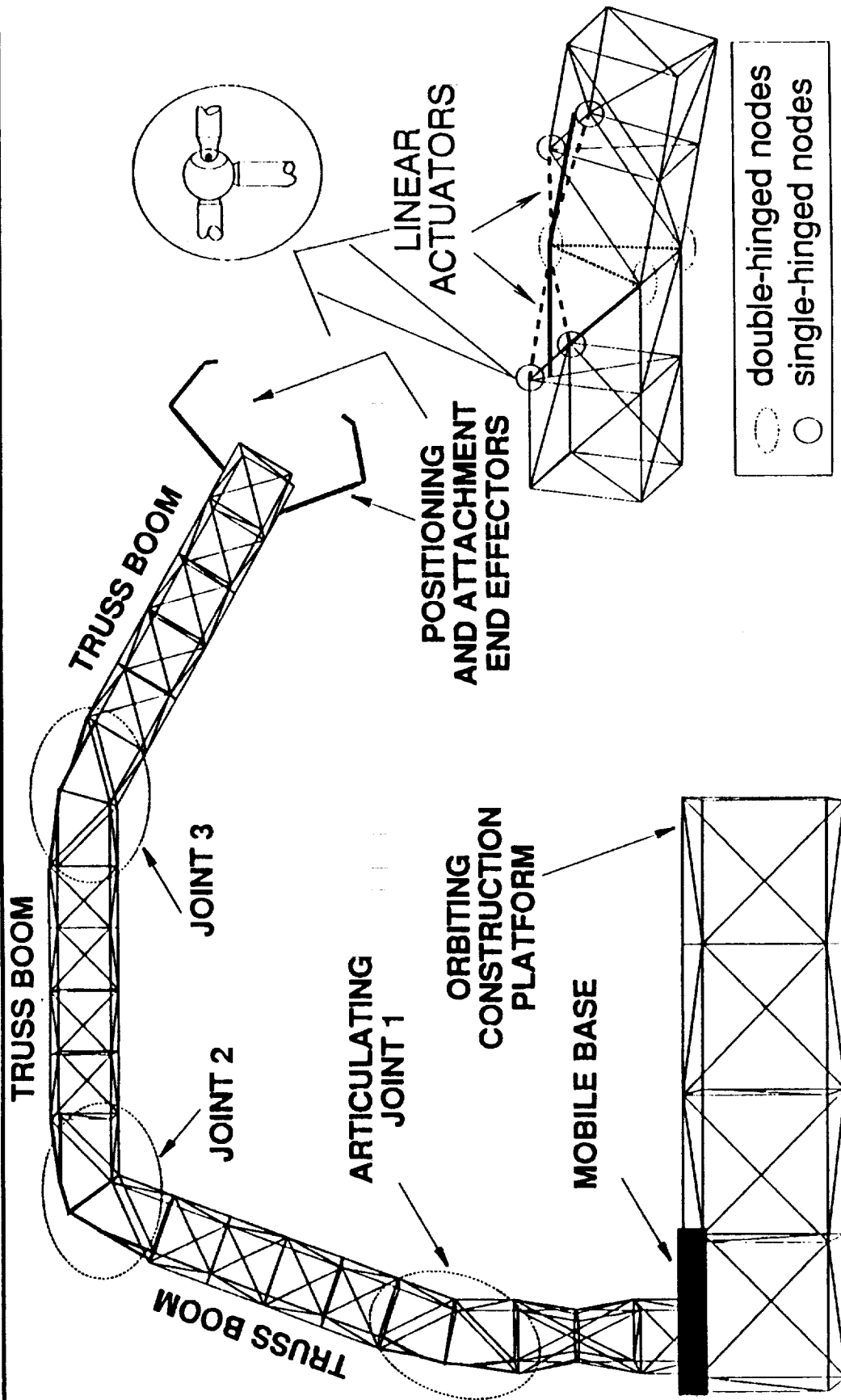
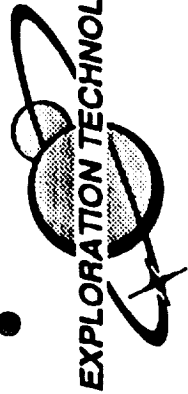

ARTICULATING JOINT

SPACE CRANE CONCEPT

SPACE CRANE

The Capability to Position and Control Spacecraft Components Precisely and Safely During Assembly Will be Achieved by Developing a Structural Space Crane Type Arm, Having Multiple Articulating Joints for Dexterity, and that can Ultimately be Operated in an Automated Mode

FEATURES

- Strength to Move and Control Large Spacecraft Components Safely
- Passive and Active "Stiffness" to Maintain a Stable and Secure Position
- Highly Controllable Large Angle Motion with Dynamic Control for Stable Trajectories
- Passive and Active Vibration Damping to Achieve Required Precision
- Reconfigurable/Adaptable Geometry to Reduce the Amount of Required On-Orbit Infrastructure
- Scaleability (Larger or Smaller Sizes) for a Variety of Applications
- Robustness and Reuseability for Long Life

The NASA logo, consisting of the word "NASA" in a bold, sans-serif font, is positioned in the bottom right corner of the page.

FUNDAMENTAL CHARACTERISTIC

DURING NORMAL OPERATIONS, THE SPACE CRANE IS A SYSTEM THAT IS CONTINUOUSLY CHANGING IT'S STATE (STIFFNESS, VIBRATION MODES, VIBRATION FREQUENCIES) DUE TO:

- PAYLOADS**
- ARTICULATION ANGLES**

HOW DO WE CONTROL THIS DEVICE?

SPACE CRANE RESEARCH APPROACH

DEVELOPMENT PHILOSOPHY

- KEEP IT SIMPLE: START WITH BASIC STRUCTURE AND ADD ONLY THOSE SYSTEMS WHICH ARE REQUIRED TO MEET THE PERFORMANCE OBJECTIVES.
- ASSESS AND CHARACTERIZE THE PERFORMANCE AT EACH LEVEL OF COMPLEXITY WITH ANALYSIS AND TESTS.

HIERARCHY

- POSITIONING CONTROL
 - Open Loop - Hardware Accuracy
 - Closed Loop - Sensor Feedback (Vision for example)
- VIBRATION CONTROL
 - Bare Structure Performance
 - "D" Strut Passive Dampers
 - Preshaped Command Input
 - Active Damping (Feedback)

SPACECRAFT COMPONENT POSITIONING AND ASSEMBLY TEST-BED

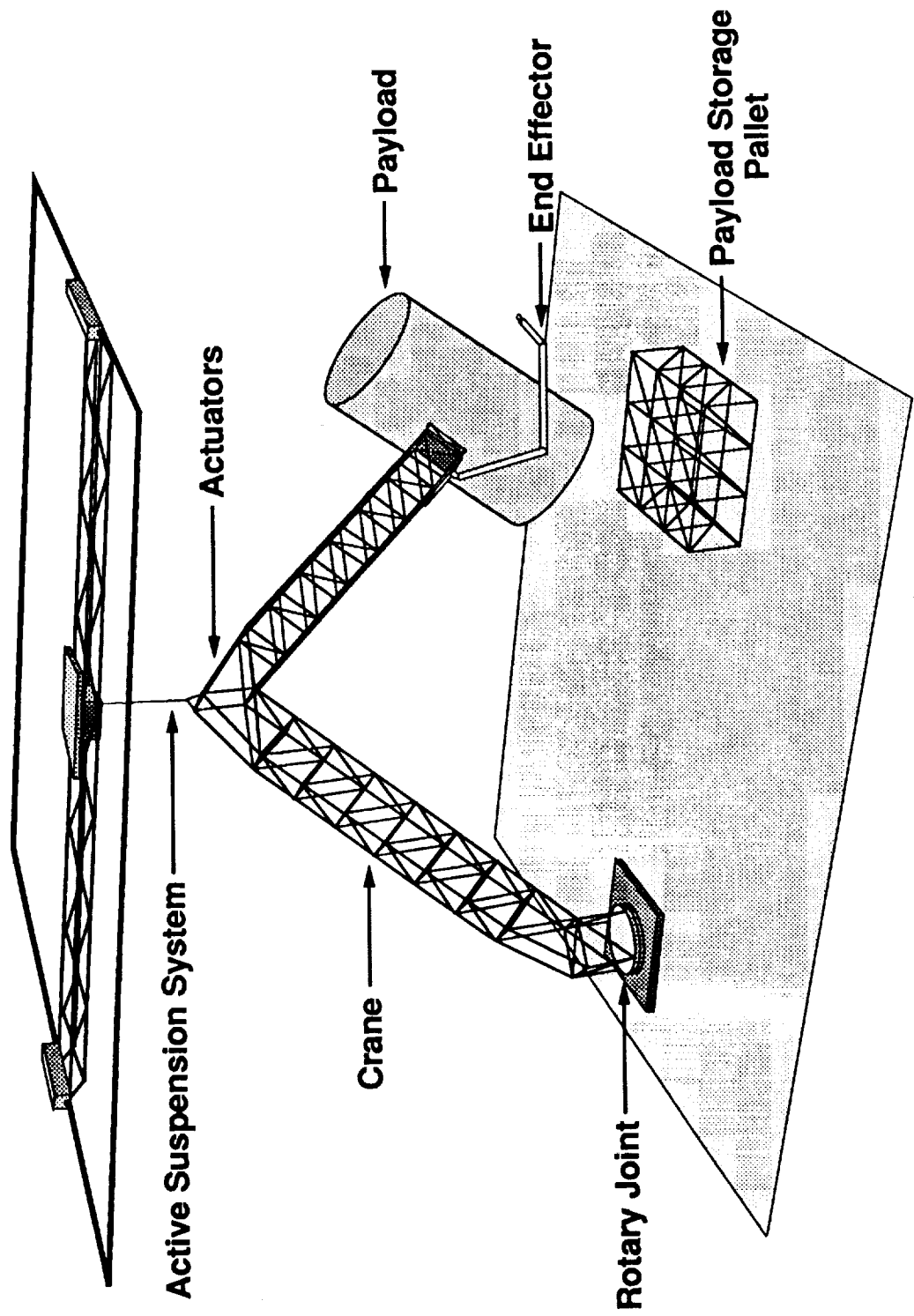

ARTICULATING JOINT TESTBED

- USES PREVIOUSLY DEVELOPED HARDWARE, WITH EXCELLENT PERFORMANCE CHARACTERISTICS, FOR THE TRUSS BOOMS**
- ALLOWS RESEARCH TO FOCUS ON THE ARTICULATING JOINT AND SPACE CRANE CONTROLS PROBLEMS**
- CAN BE RAPIDLY RECONFIGURED**
- GIVES RAPID COMPONENT REPLACEMENT AND/OR MODIFICATION CAPABILITY**

CONCLUDING REMARKS

NASA

- HAVING IN-SPACE ASSEMBLY AND CONSTRUCTION CAPABILITY WILL PROVIDE A GREAT DEAL OF FLEXIBILITY FOR FUTURE MISSION PLANNING AND SPACECRAFT DESIGN**
- THE SPACE CRANE HAS MANY DESIRABLE FEATURES AND CAPABILITIES FOR AN ON-ORBIT ASSEMBLY DEVICE AND THUS, SHOULD BE AN INTEGRAL COMPONENT IN ON-ORBIT ASSEMBLY SCENARIOS**

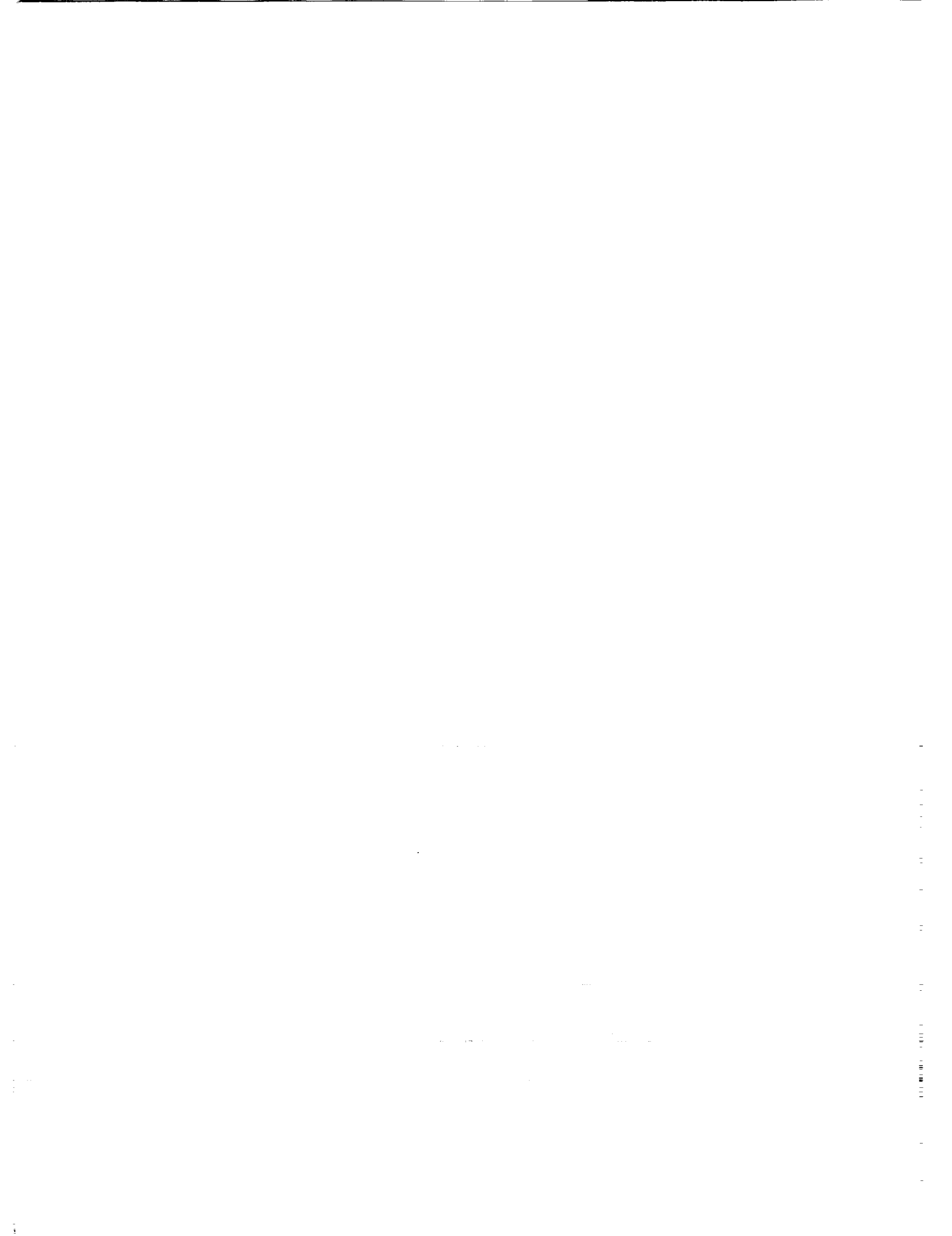

ANALYSIS AND TESTING OF A SPACE CRANE ARTICULATING JOINT TESTBED

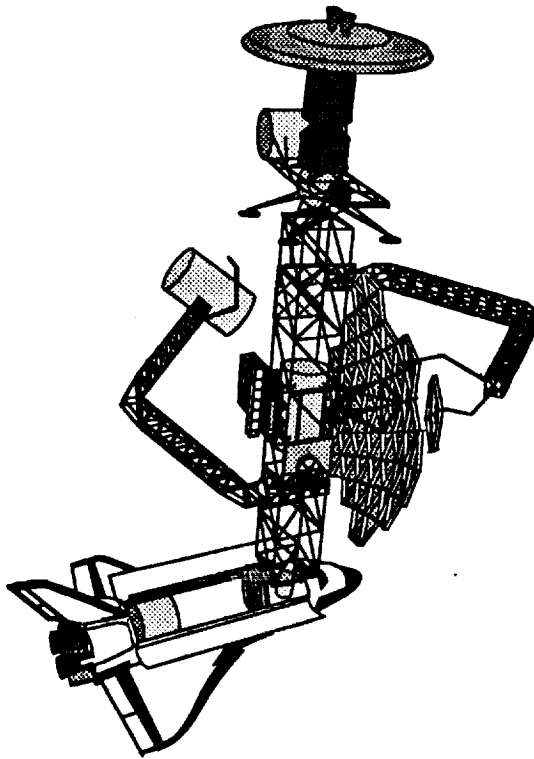

"Finite Element" Dynamic Model

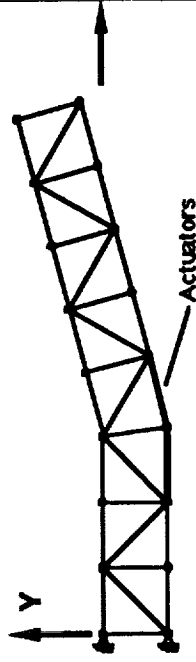

PRESENTED BY

THOMAS R. SUTTER AND K. CHAUNCEY WU
SPACECRAFT STRUCTURES BRANCH

SPACE CRANE CONCEPT WITH MOBILE BASE

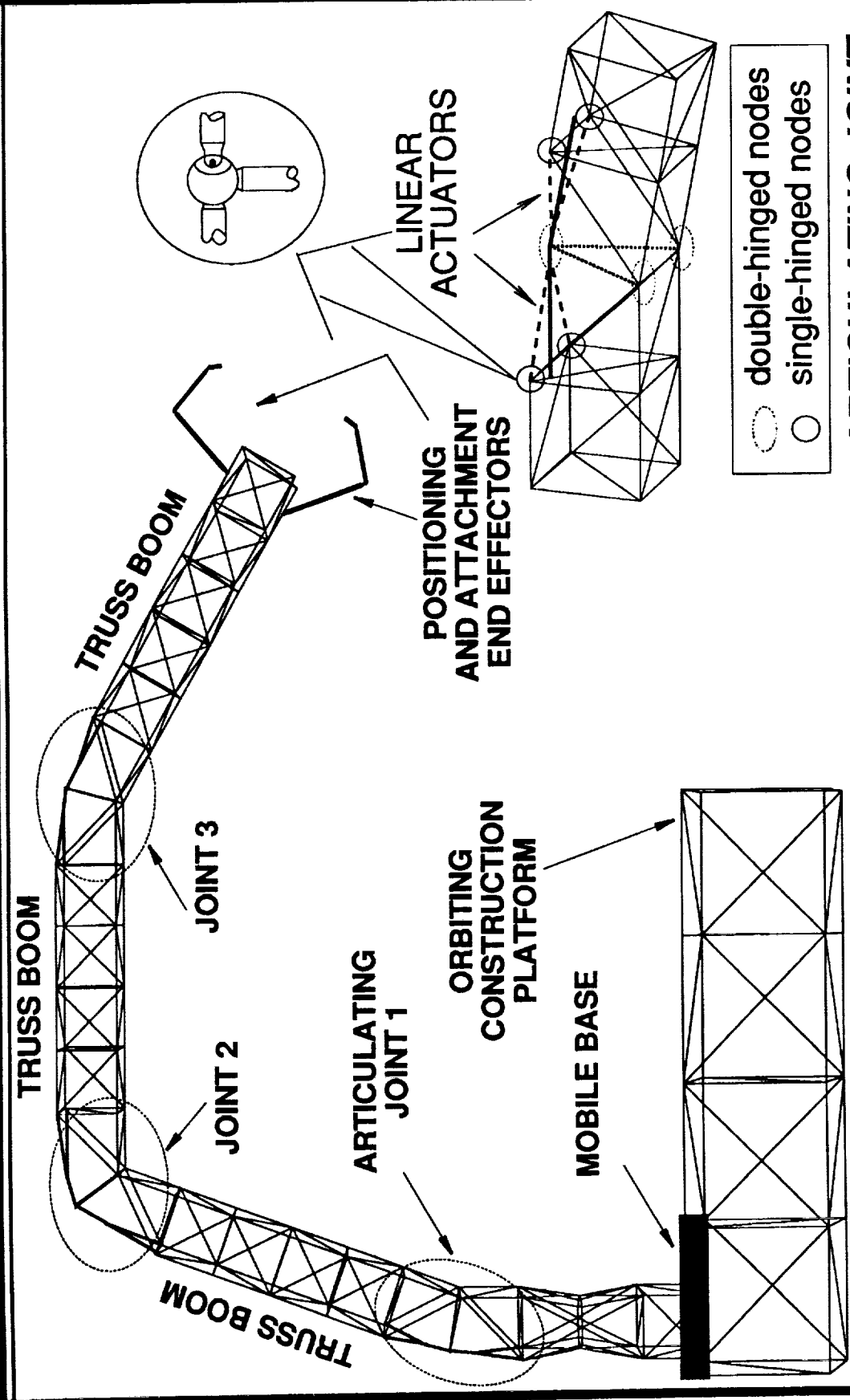

ARTICULATING JOINT

SPACE CRANE CONCEPT

MECHANICAL VERSUS STRUCTURAL ARTICULATING JOINT



SHUTTLE RMS

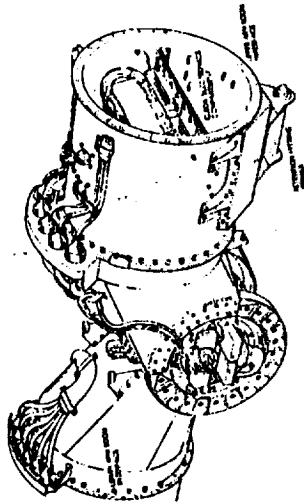

ELBOW JOINT
(MECHANICAL)

SPACE CRANE

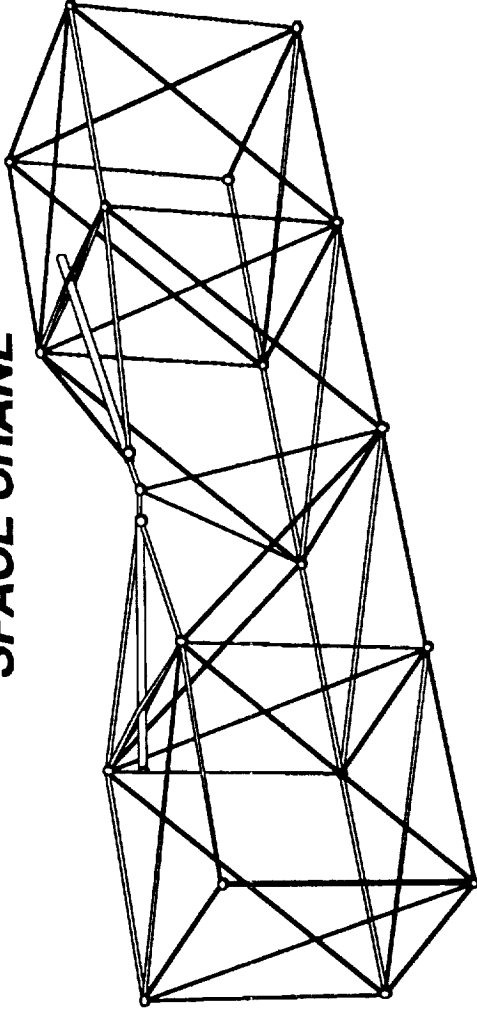

ARTICULATING JOINT
(STRUCTURAL)

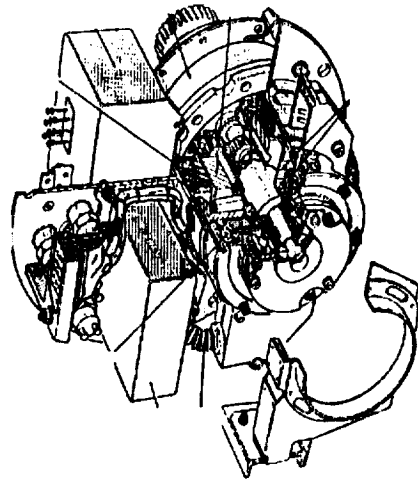

MOTOR MODULE

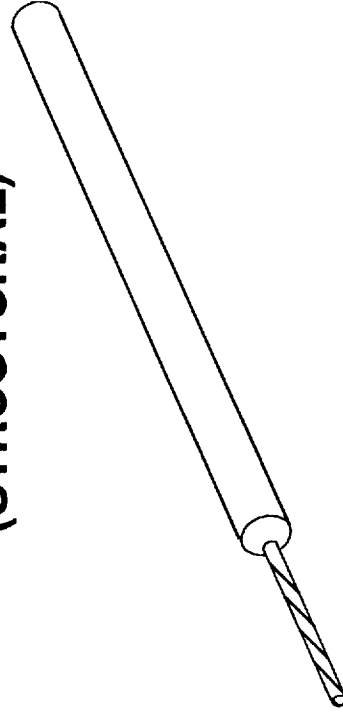

LINEAR BALL SCREW
ACTUATOR

SPACE CRANE ARTICULATING JOINT TEST BED FABRICATED



ARTICULATING JOINT TEST BED AND REFERENCE TRUSS

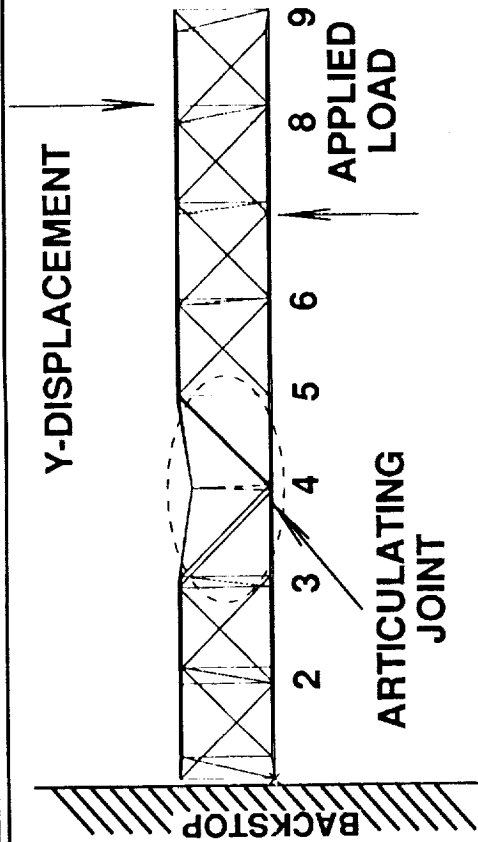
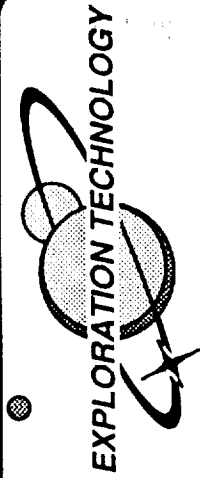

ARTICULATING JOINT TEST BED

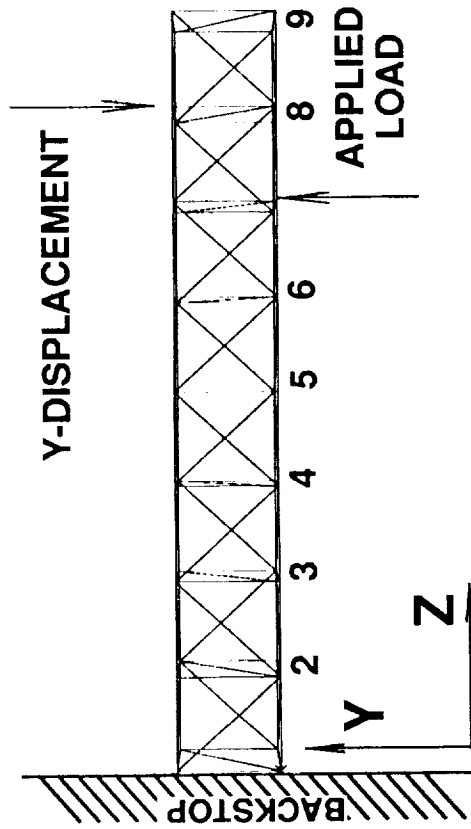

REFERENCE TRUSS

STATIC AND DYNAMIC CHARACTERIZATION COMPLETED FOR SPACE CRANE REFERENCE TRUSS CONFIGURATION

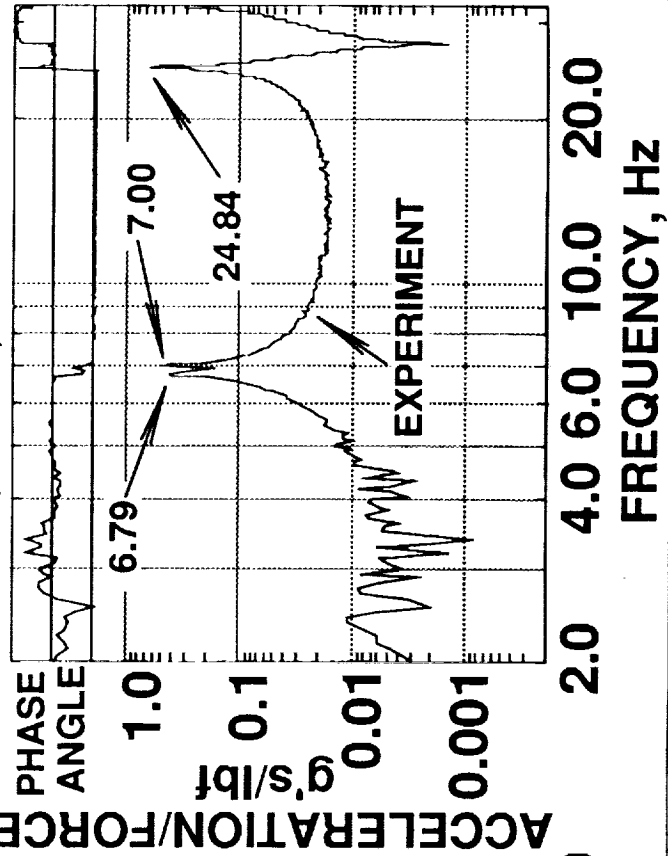
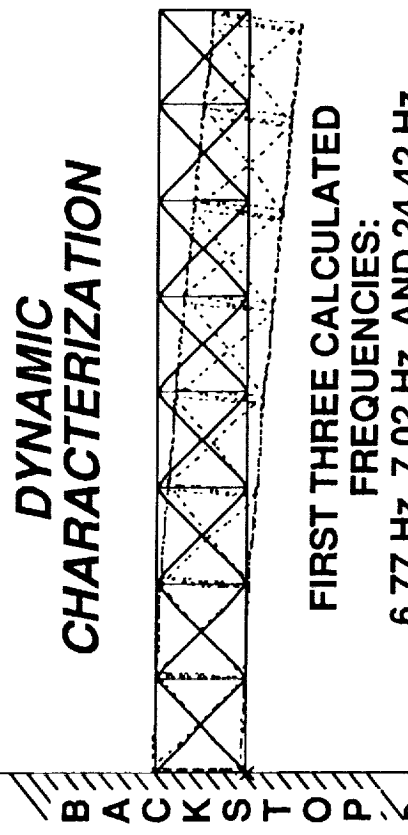
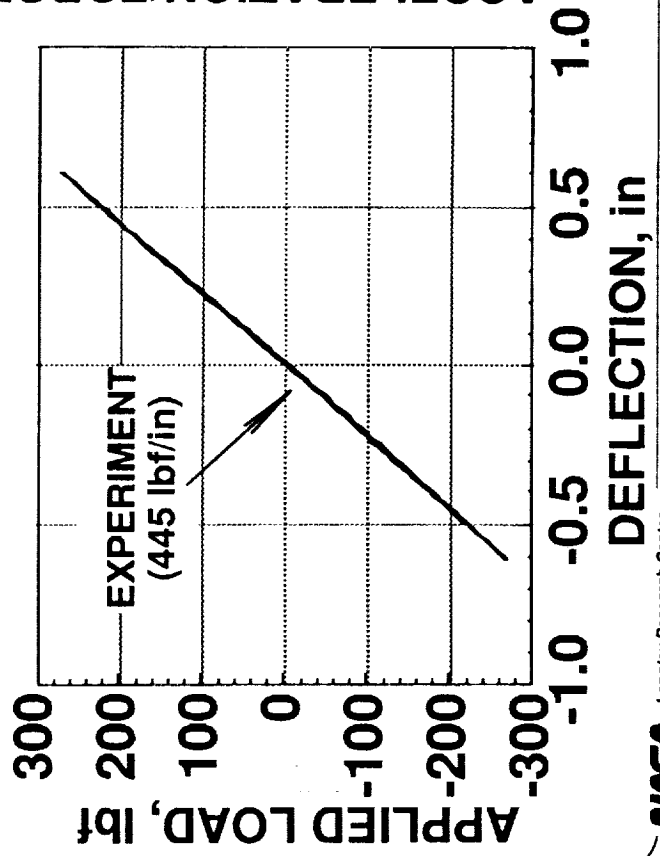
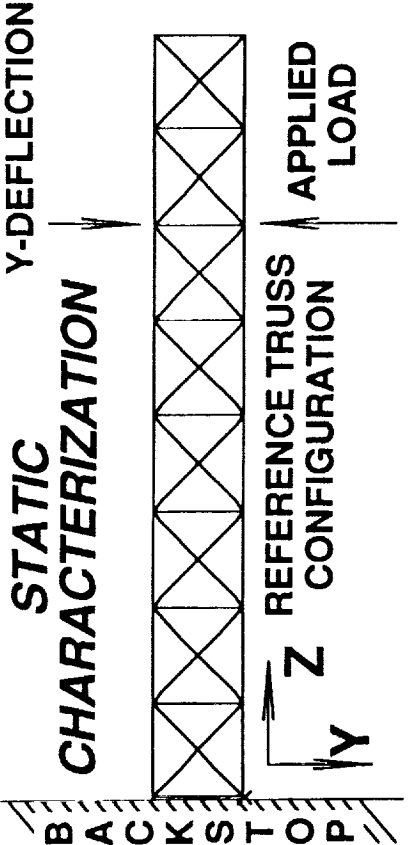

IMPROVED LINEAR ACTUATORS REDUCE ARTICULATING JOINT TEST BED BACKLASH

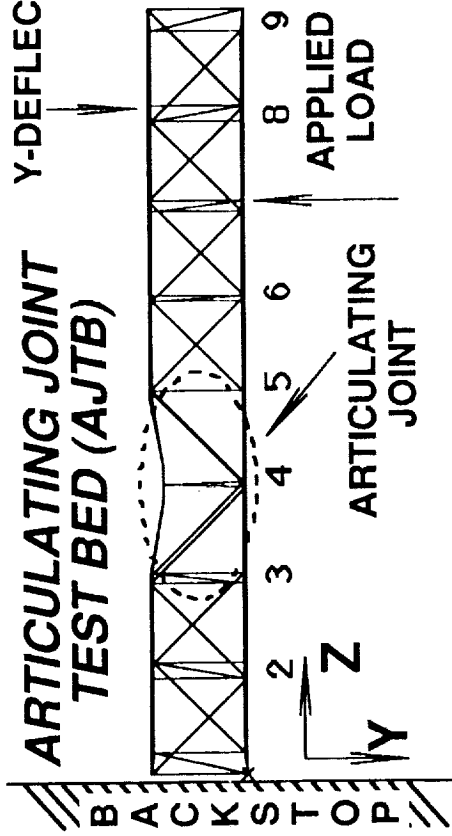

LINEAR ACTUATORS

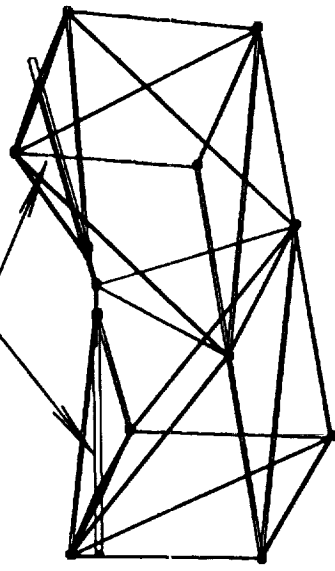

ARTICULATING JOINT DETAIL

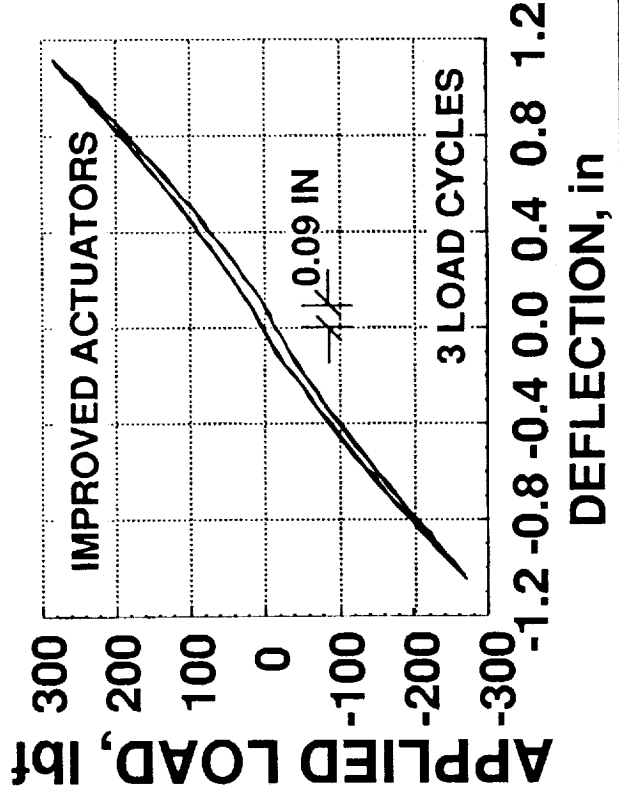
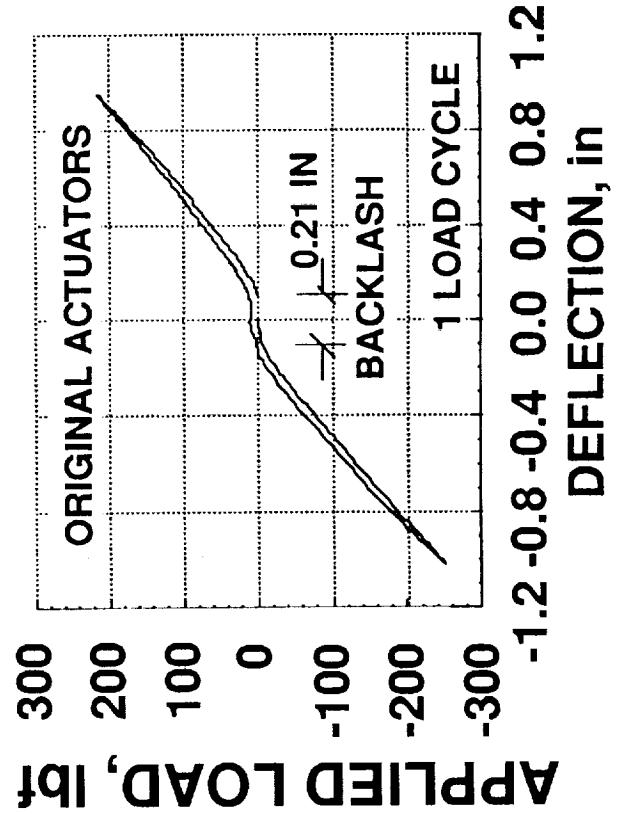

1-DOF SPACE CRANE SLEW MANEUVER

"Finite Element" Dynamic Model

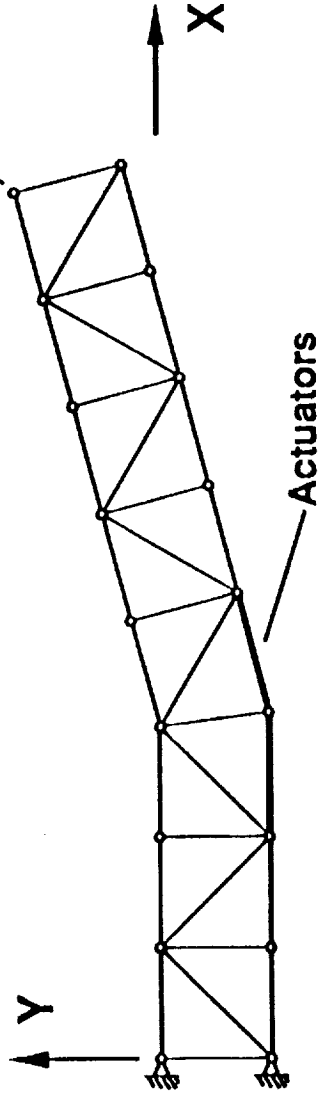

- Motion in X-Y plane only
- Truss members modeled as axial springs
- No EAL interface required
- Easy to model discrete dampers

Actuator Extension Time History

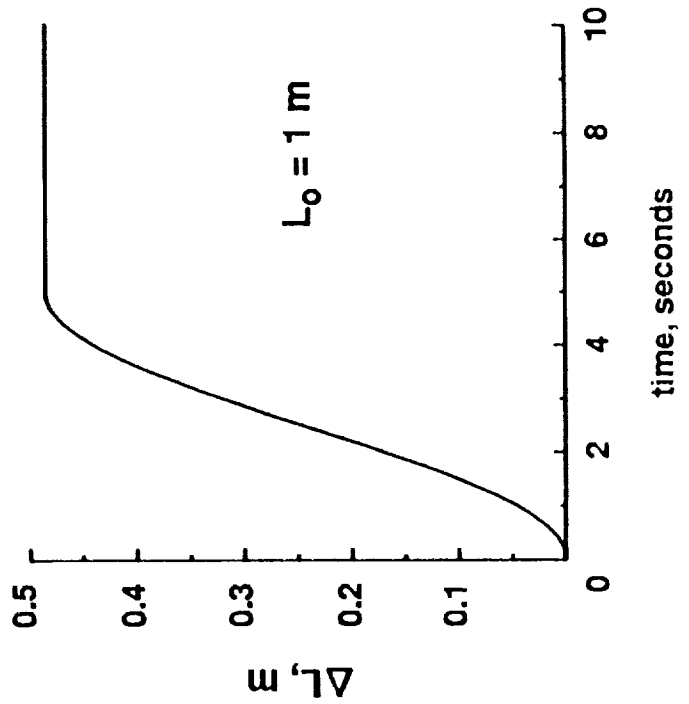

Node 18 Position

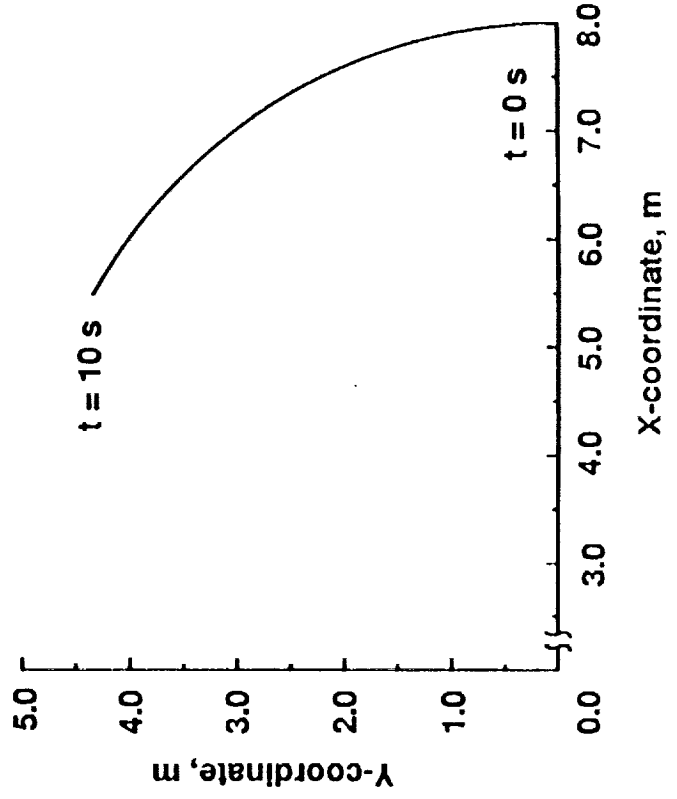

Boom 2 Tip Transient Response Finite Element Dynamic Model

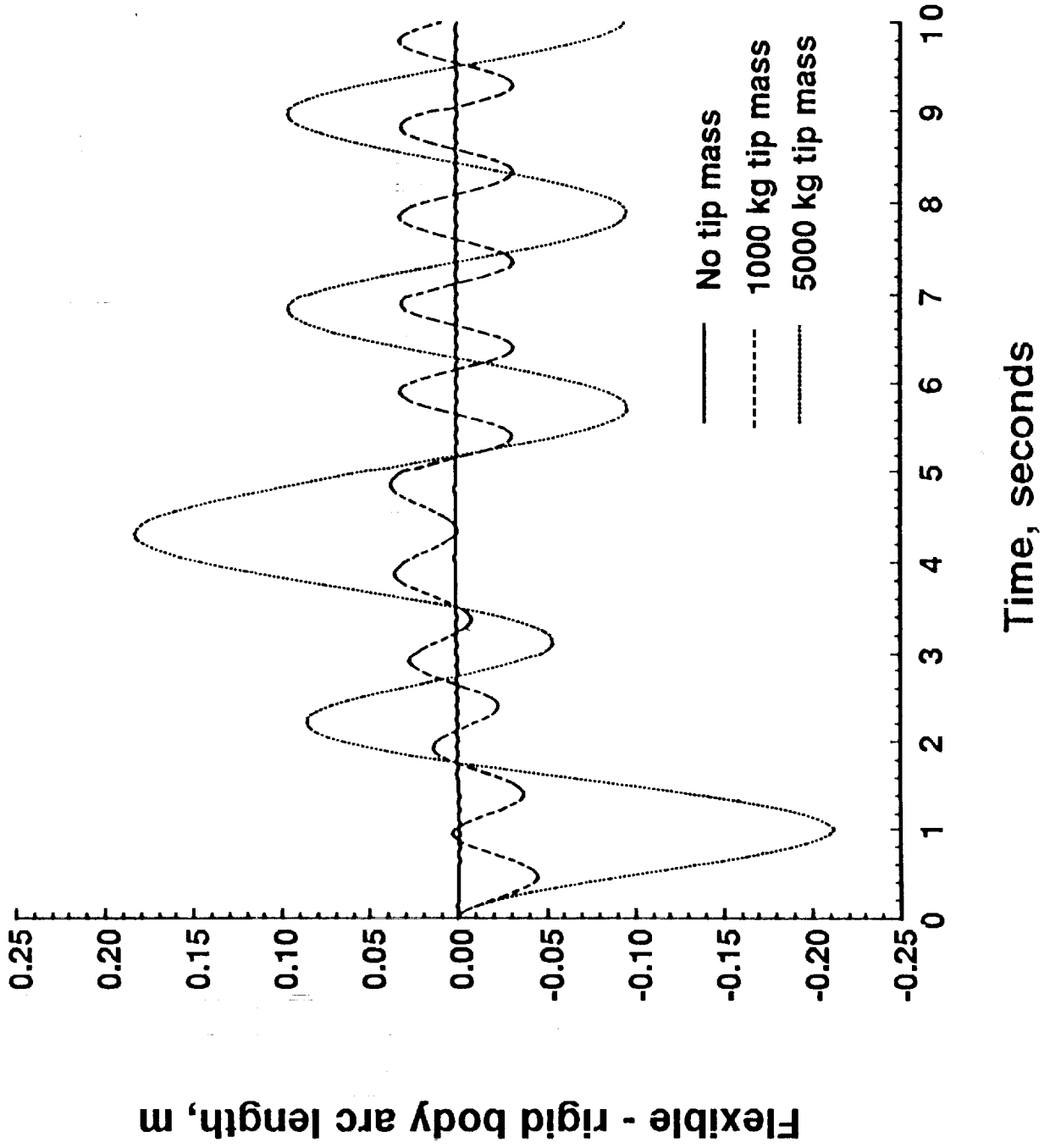

**Boom 2 Tip Transient Response
Finite Element Dynamic Model
D-Struts in Bay 1**

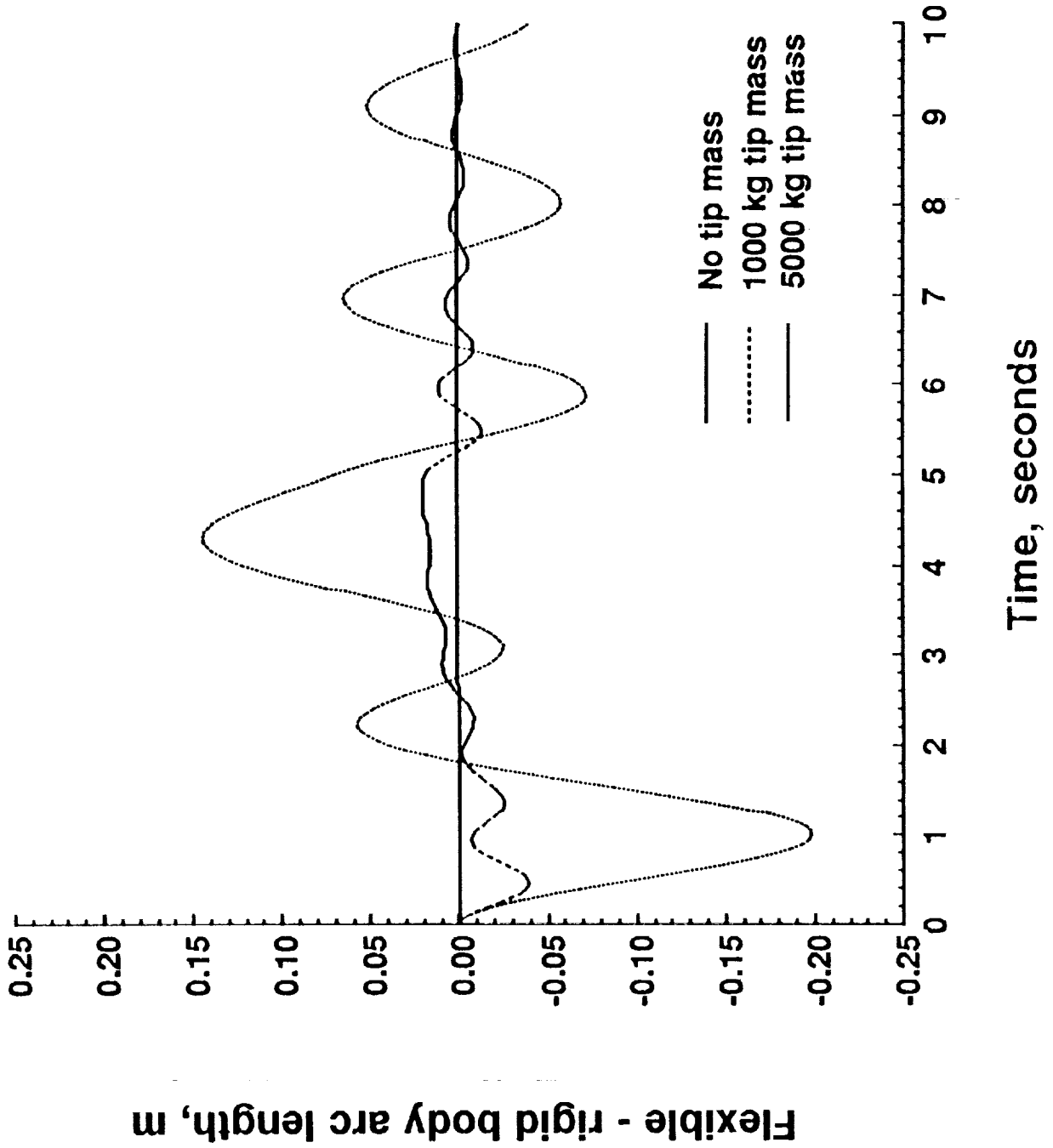

1-DOF SPACE CRANE SLEW MANEUVER

"Component Mode" Structural Dynamics

- Booms modeled with beam elements
- Transverse shearing of beams included
- Lowest three flexible-body modes used
- Clamp-free boundary conditions applied

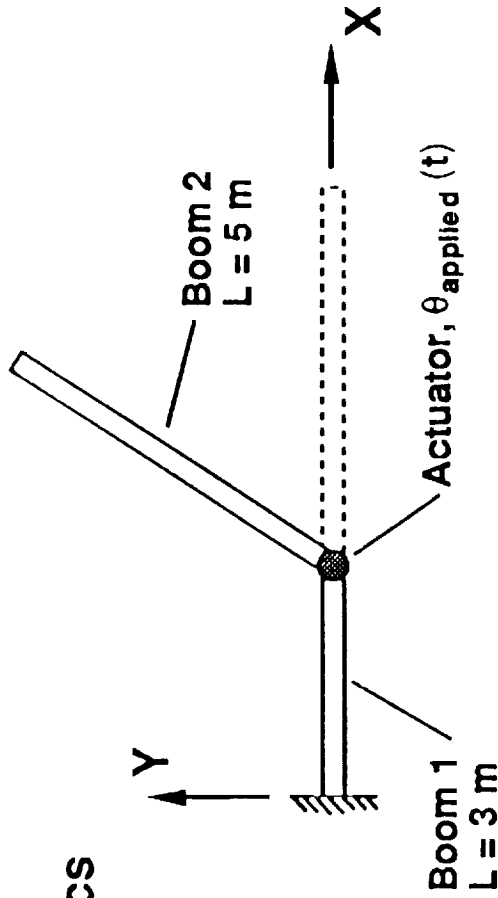
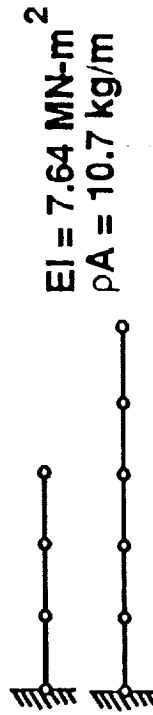

Applied Rotation Time History

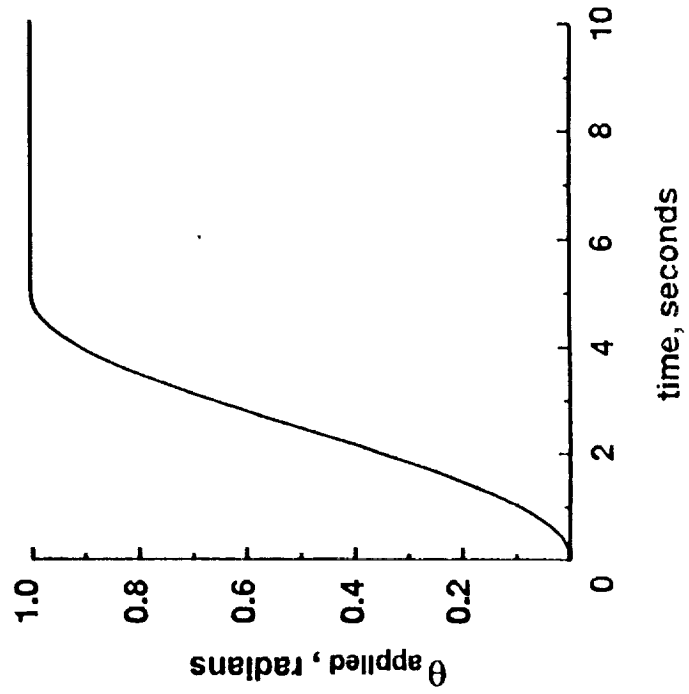

Boom 2 Tip Position

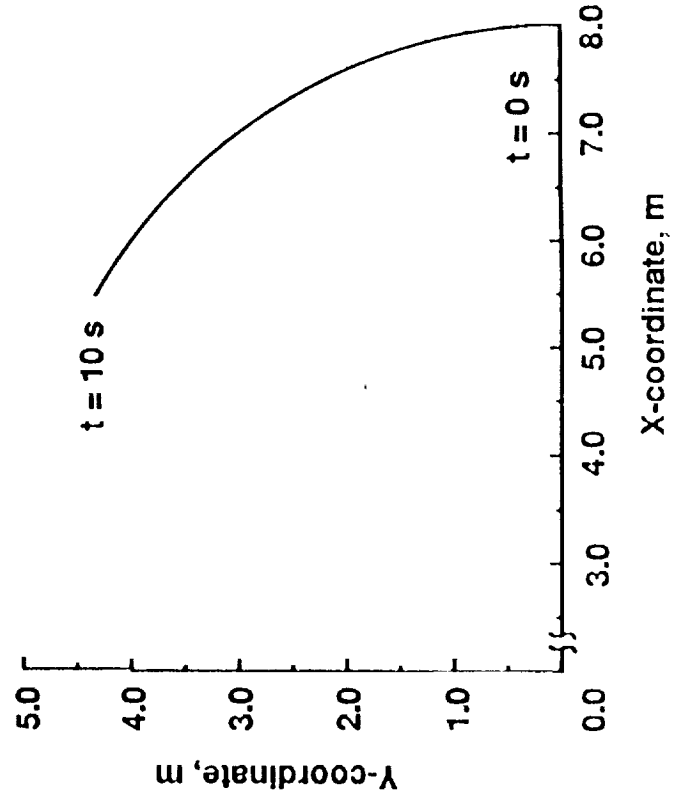

Boom 2 Tip Transient Response Shear-Corrected Component Modes Torque Driver Profile

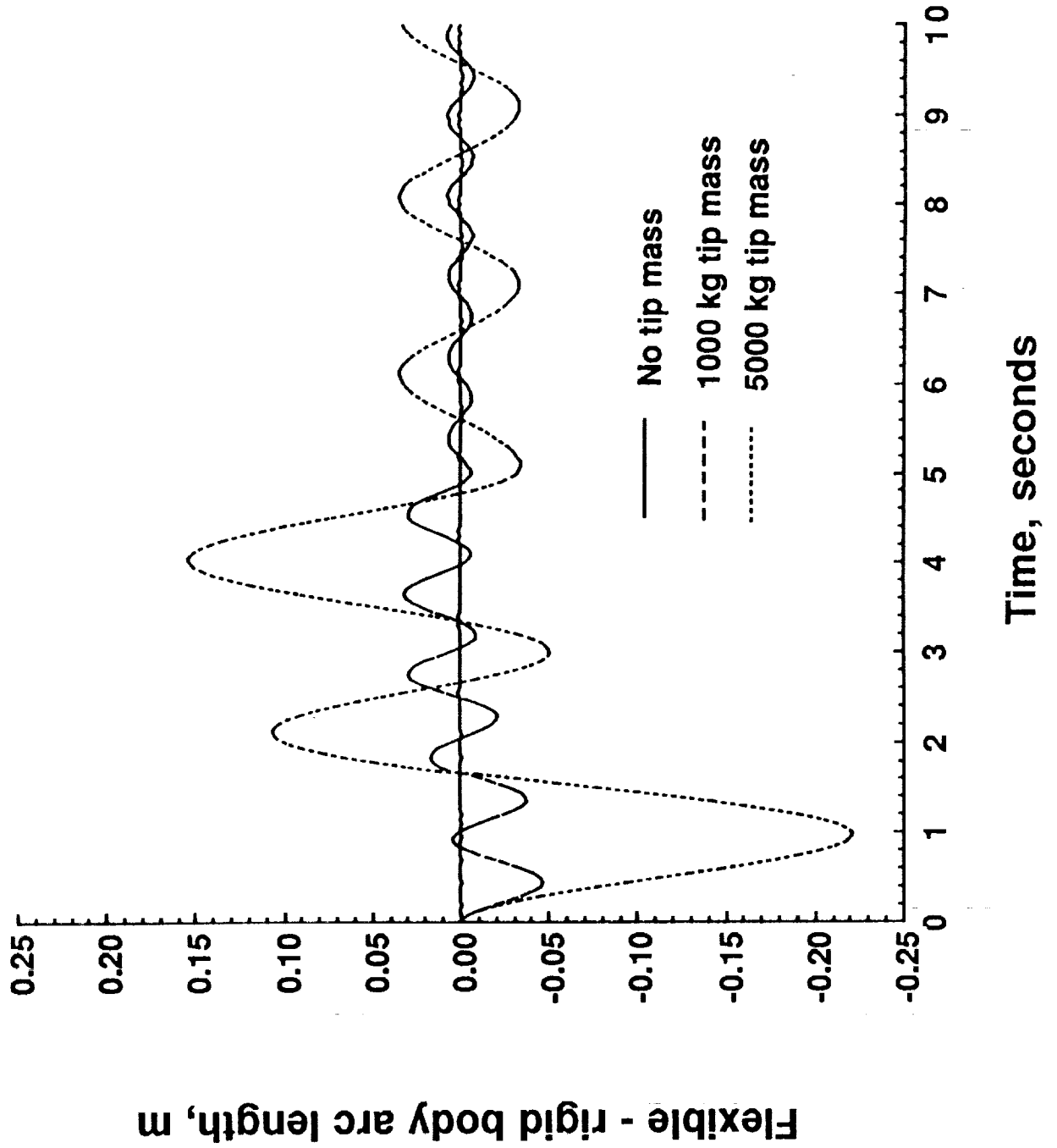

Peak Root Member Force vs. Slew Time Torque Driver Profile

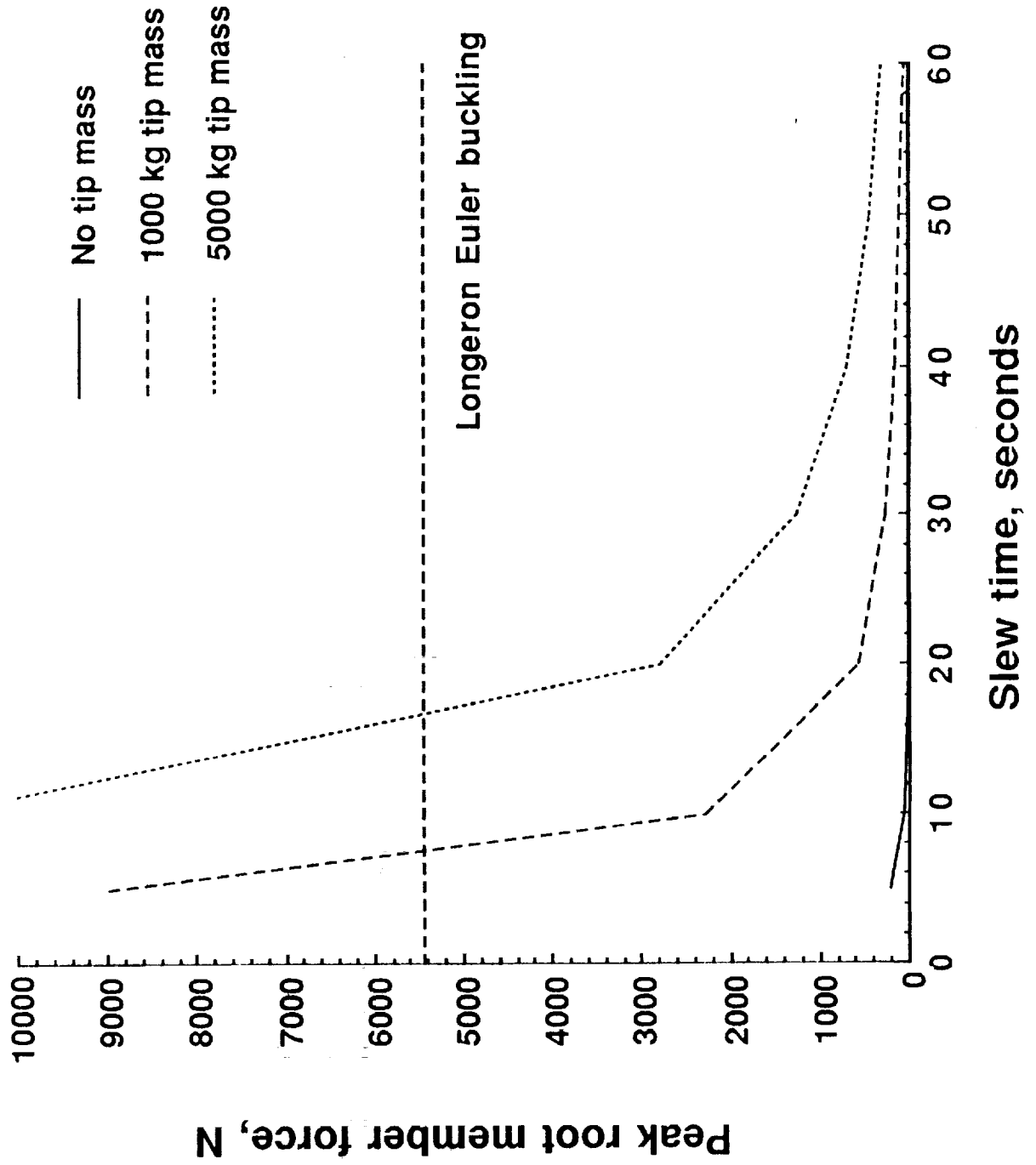

OPEN-LOOP CONTROL OF SPACE CRANE MOTION

Proposed Approach: Design actuator extension profile externally

Use LabVIEW 2 to implement the extension profile and measure the transient response and loads

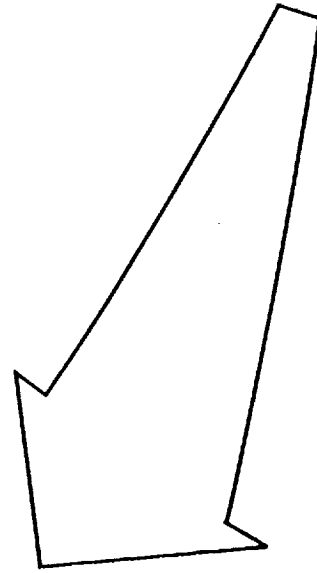
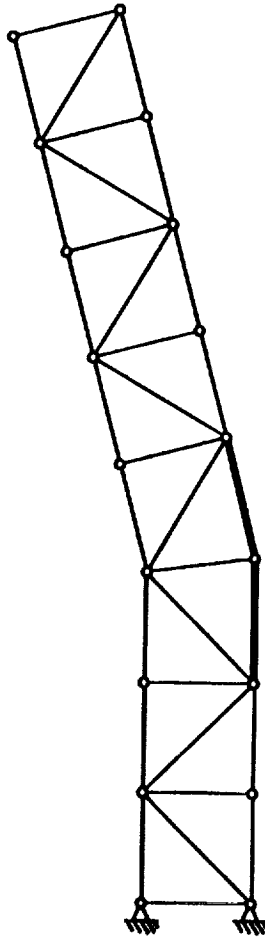

Actuator Extension Time History

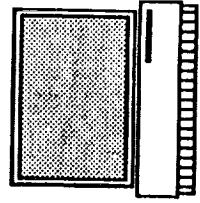
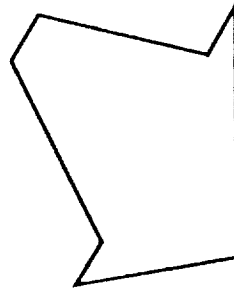
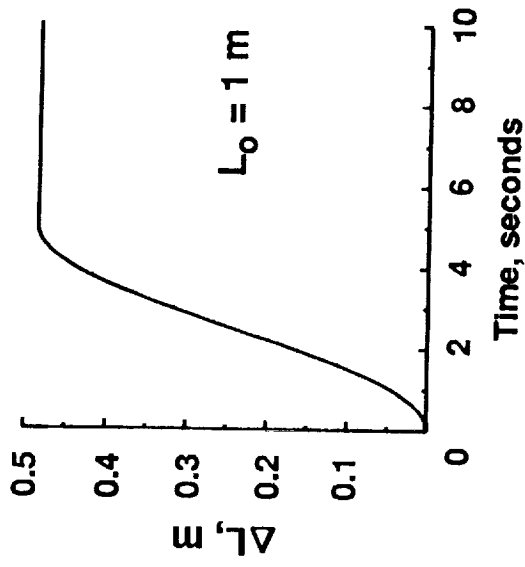

LabVIEW 2

Automated Assembly of Large Space Structures

Marvin D. Rhodes

Spacecraft Structures Branch

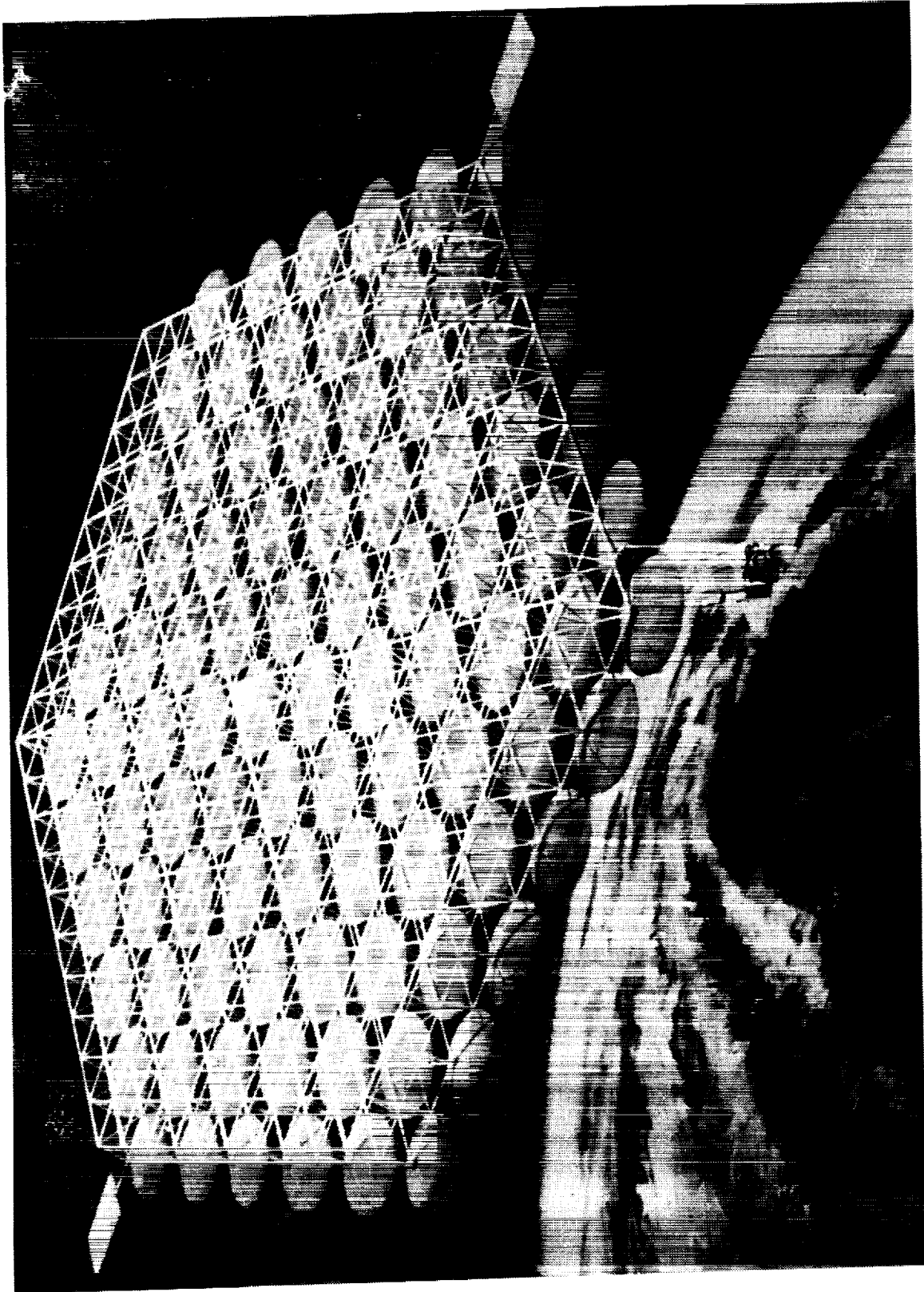

Sketch of Proposed Satellite Supported by Tetrahedral Truss Platform

TELEROBOTIC ASSEMBLY FACILITY

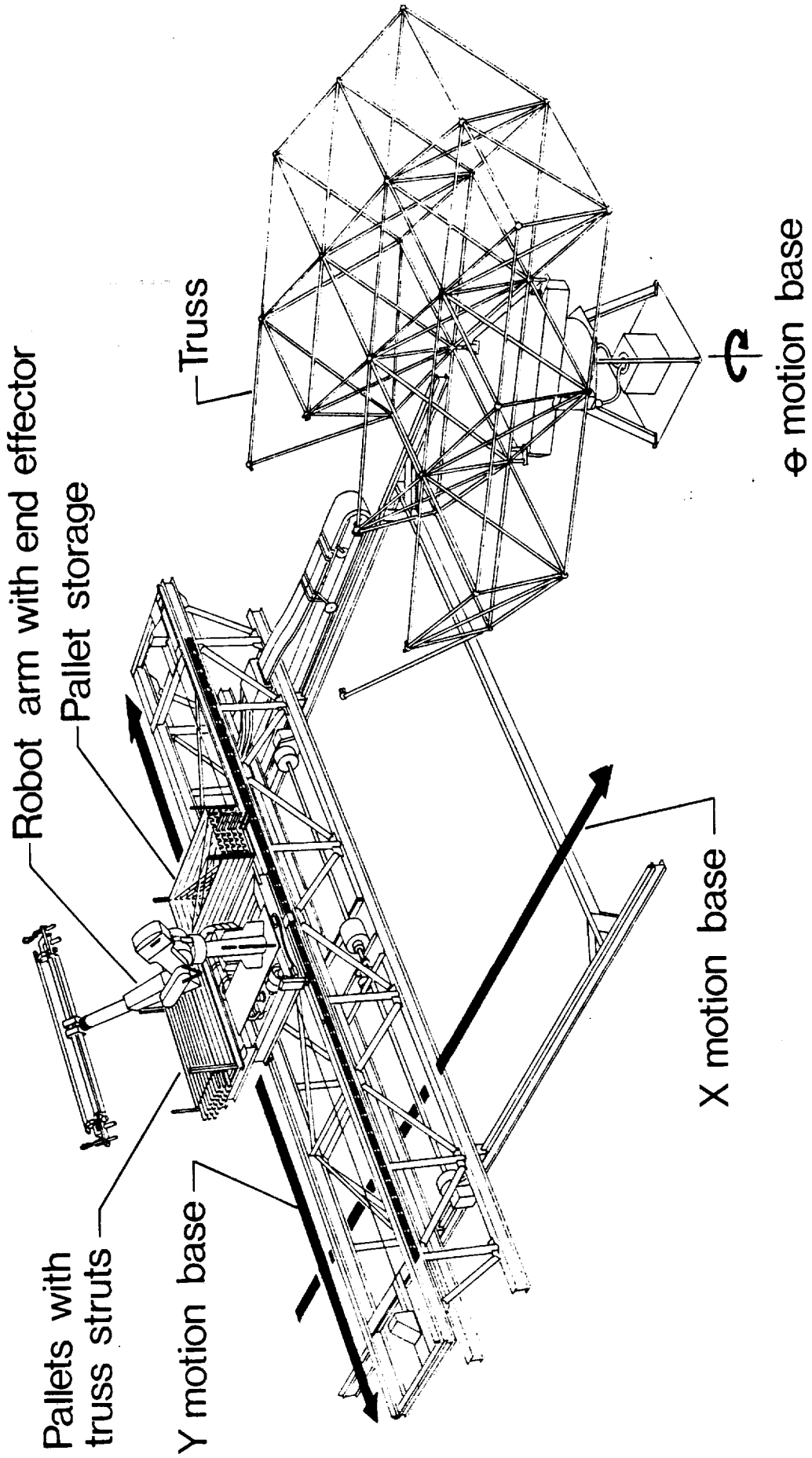

ORIGINAL PAGE
BLACK AND WHITE PHOTOGRAPH

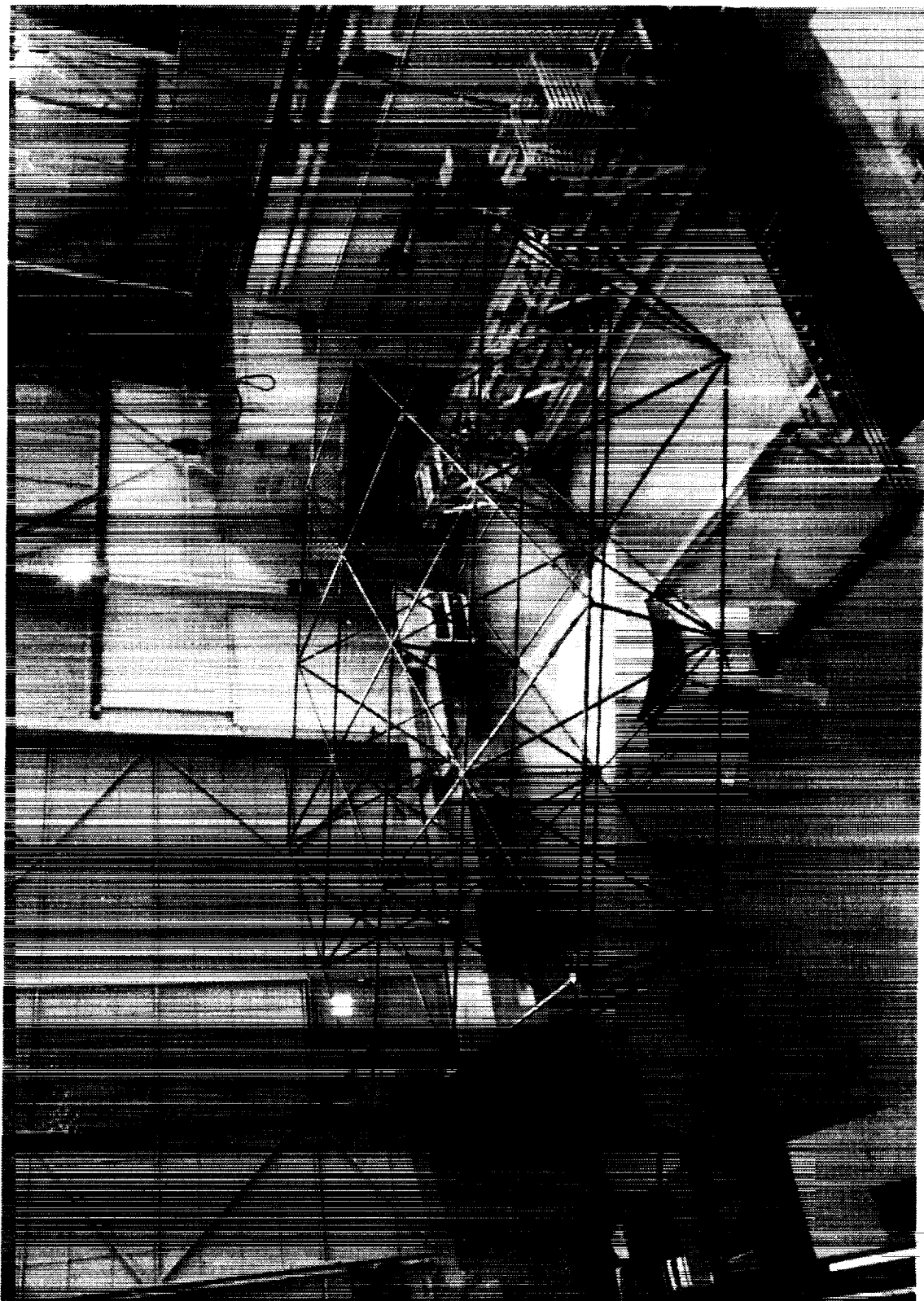

Photo of Test Lab for Automated Assembly of Large Space Structures

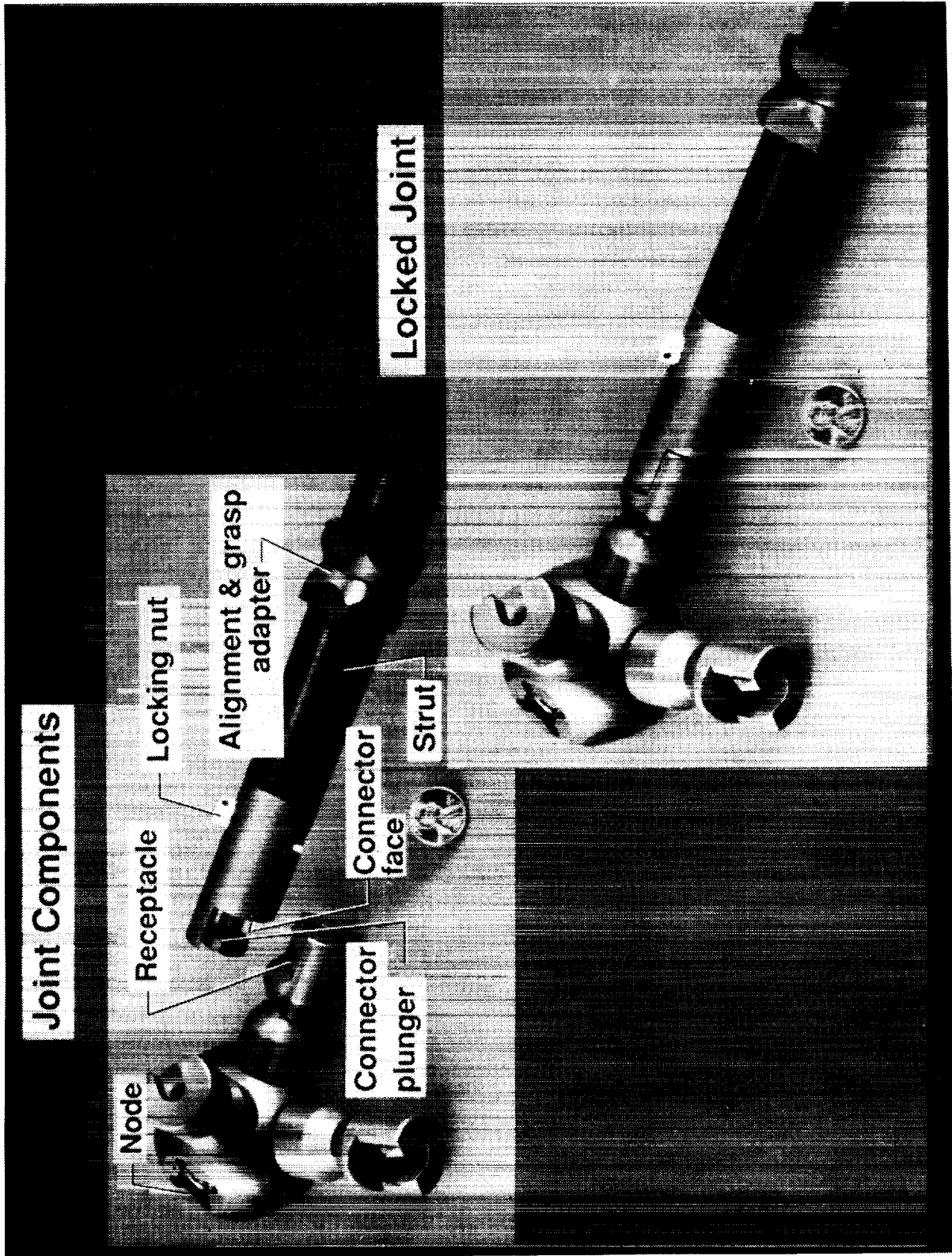
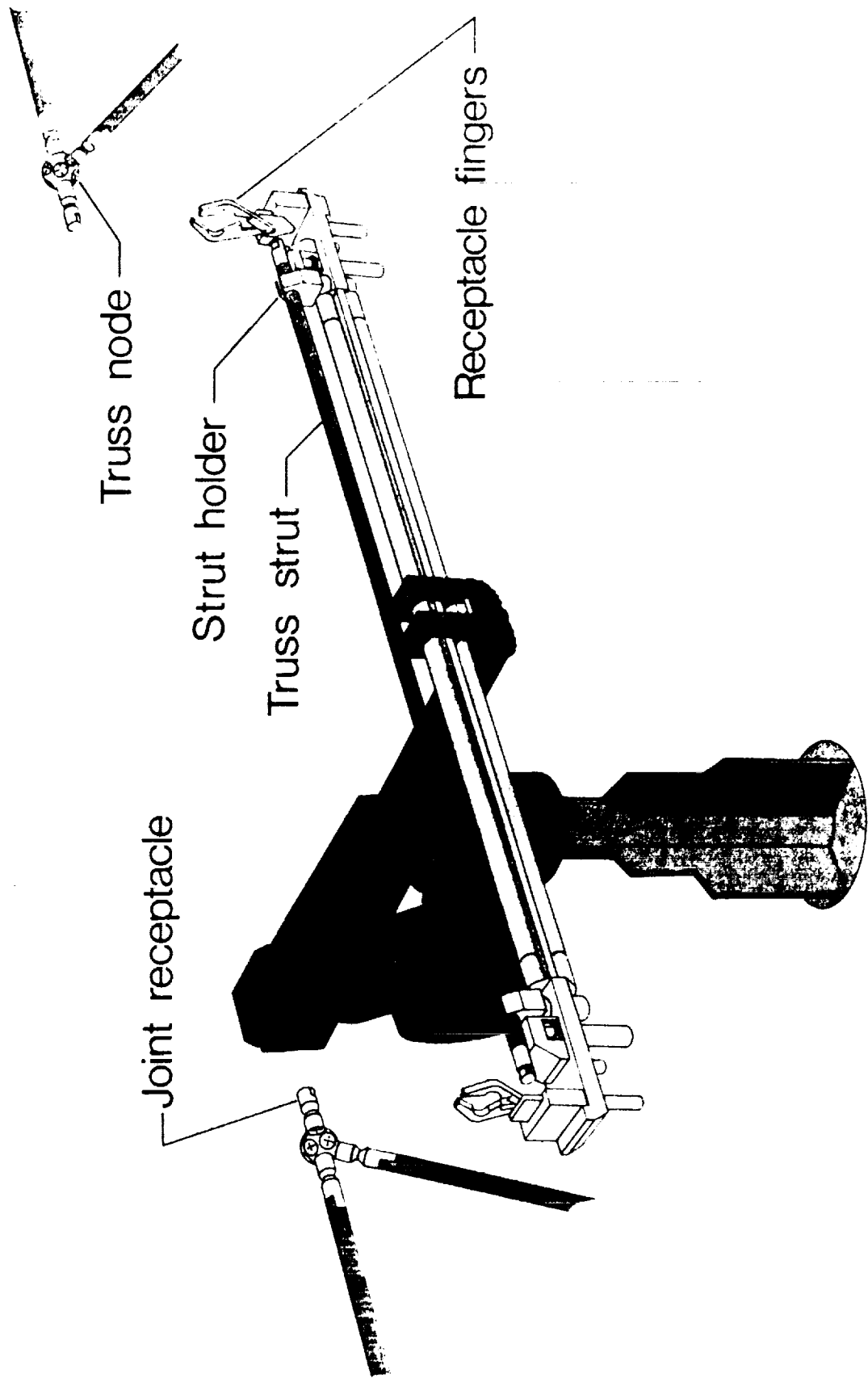
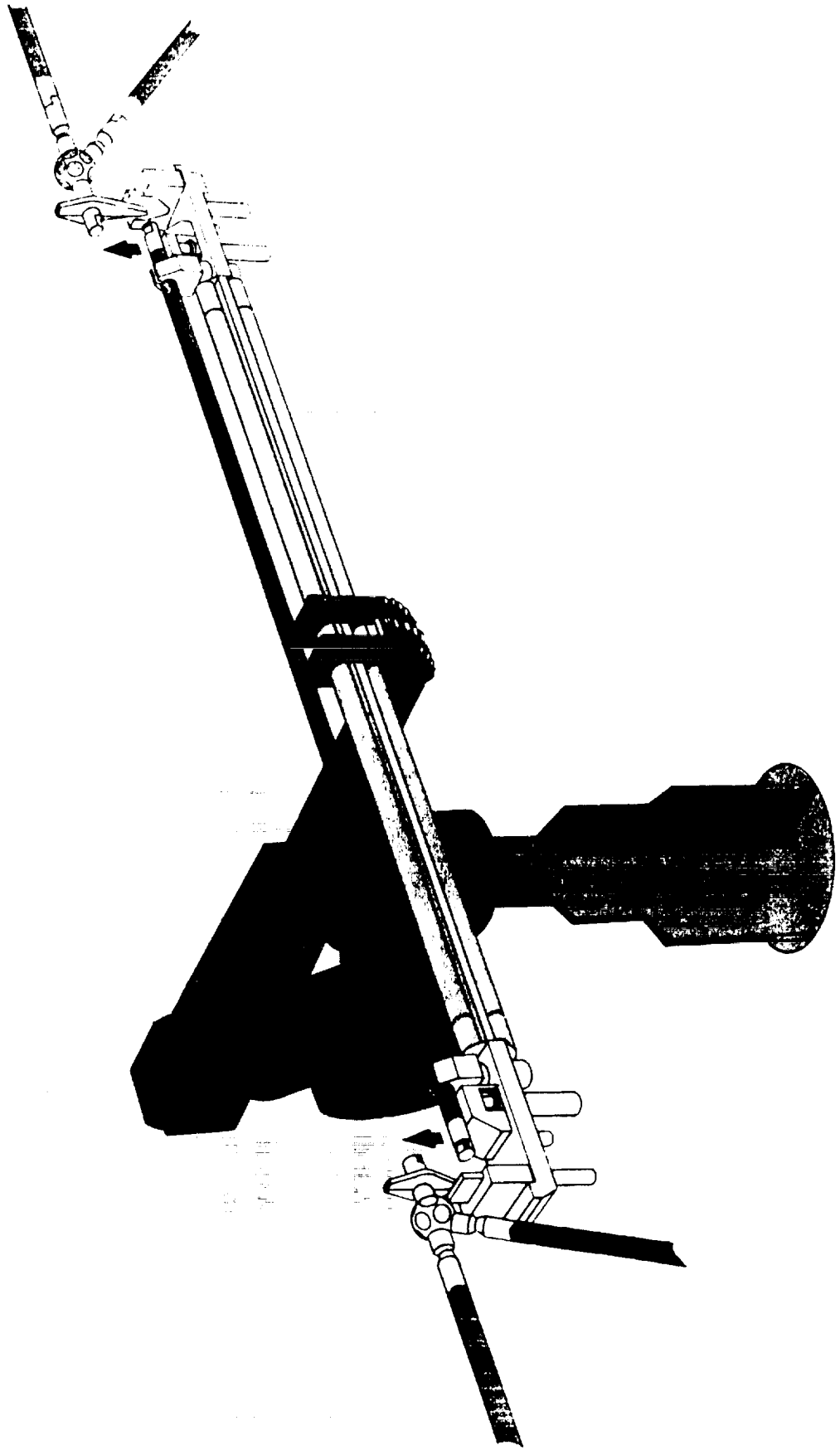

Photo of Truss Joint Connector in the Locked and Unlocked Condition

ROBOT END EFFECTOR



ROBOT END EFFECTOR



Assembly Projected Time

Activity	Current Test (Min-Sec)	Projected (Min-Sec)
Move to Canister Acquire Point	0-37	0-20
Acquire Strut in End Effector	2-08	0-41
Move Arm To Rest Position	0-07	0-07
Position Motion Base Components	0-46
Move Arm to Install Position	1-30	1-15
Install Strut	2-49	0-43
Return Arm to Rest Position	<u>1-13</u>	<u>1-00</u>
Total Assembly Time	9-10	4-06

Projected Time Assumes Parallel Processing and Distributed Control
 Current Operation Involves 48 Communication Commands/Strut @ 1 Sec/Command

AUTOMATED STRUCTURES ASSEMBLY FACILITY
CURRENT CONTROL HIERARCHY

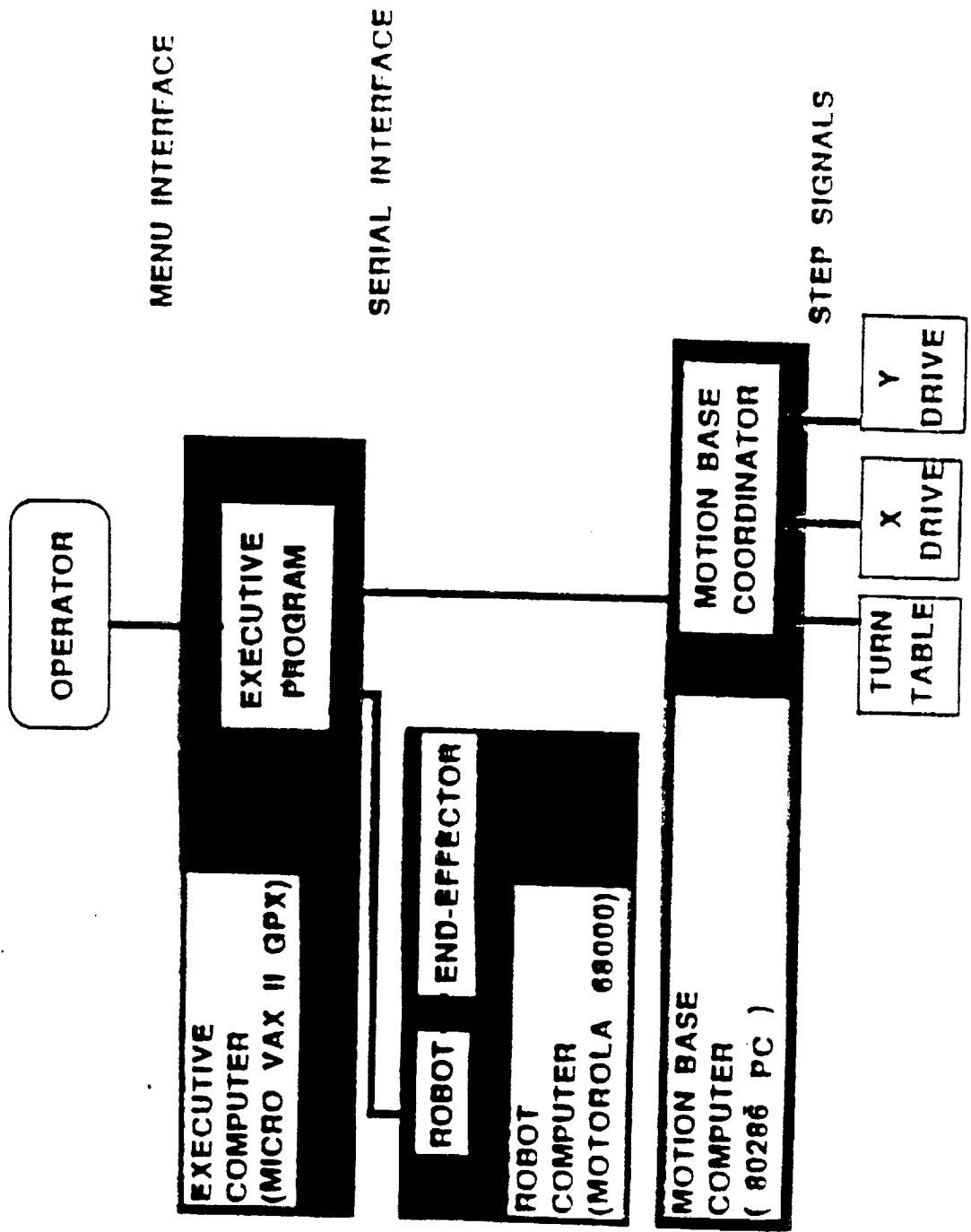

Assembly Problem Summary

On Average There Are 30-50 Operator Intervention Problems Encountered During an Assembly/Disassembly Test

66% Are Positioning Errors Associated with Joint Receptacle Capture

33% Are Positioning Errors Associated with Inserting the Strut into the Receptacle

1% Result from Struts Length Errors

Correction of All Except Strut Length Errors Are Handled by the Operator from the Console by Adjusting the Robot Position or Force/Torque Balance Repositioning (Corrected by Accurate Positioning Using the Proposed Vision System)

Strut Length Errors Require Going-Over-The-Fence (Corrected by Better Guidance in Joint)

Observations and Results

Hardware Design

Grappling the receptacle for strut installation is recommended

Passive guidance is required for positioning of mating components

Positive actuation required for mechanism operation

Software Design and System Control

Complete system data base required to control all operations

Operator's role in system control key to software design

Every operation must be interruptible and reversible

System must be under computer control

Concise naming conventions is vital to operator control

Sensor Monitoring and Error Recovery

Full instrumentation of each end-effector component is essential

Video camera coverage is necessary for error recovery operations

Automatic roll-back to preexisting state is very desirable feature

Compliant moves provided by force/torque feedback

Recommendations/Conclusions

Graphic simulations and component bench testing will not substitute for full hardware test experience

Significant portion of system capability empirically developed

Automated assembly is a viable option for in-space construction

Current Plans/Developments

Automated Machine Vision Guidance-E. Cooper

Distributed Microprocessor Control-B. Doggett

Installation of Large Panels-P. Quach

Rule Based Expert System Programming-C. Allen

Future Work-R. Will

Parallel System Control

Computer Graphics

Automated Path and Sequence Planning

Other Structural Configurations

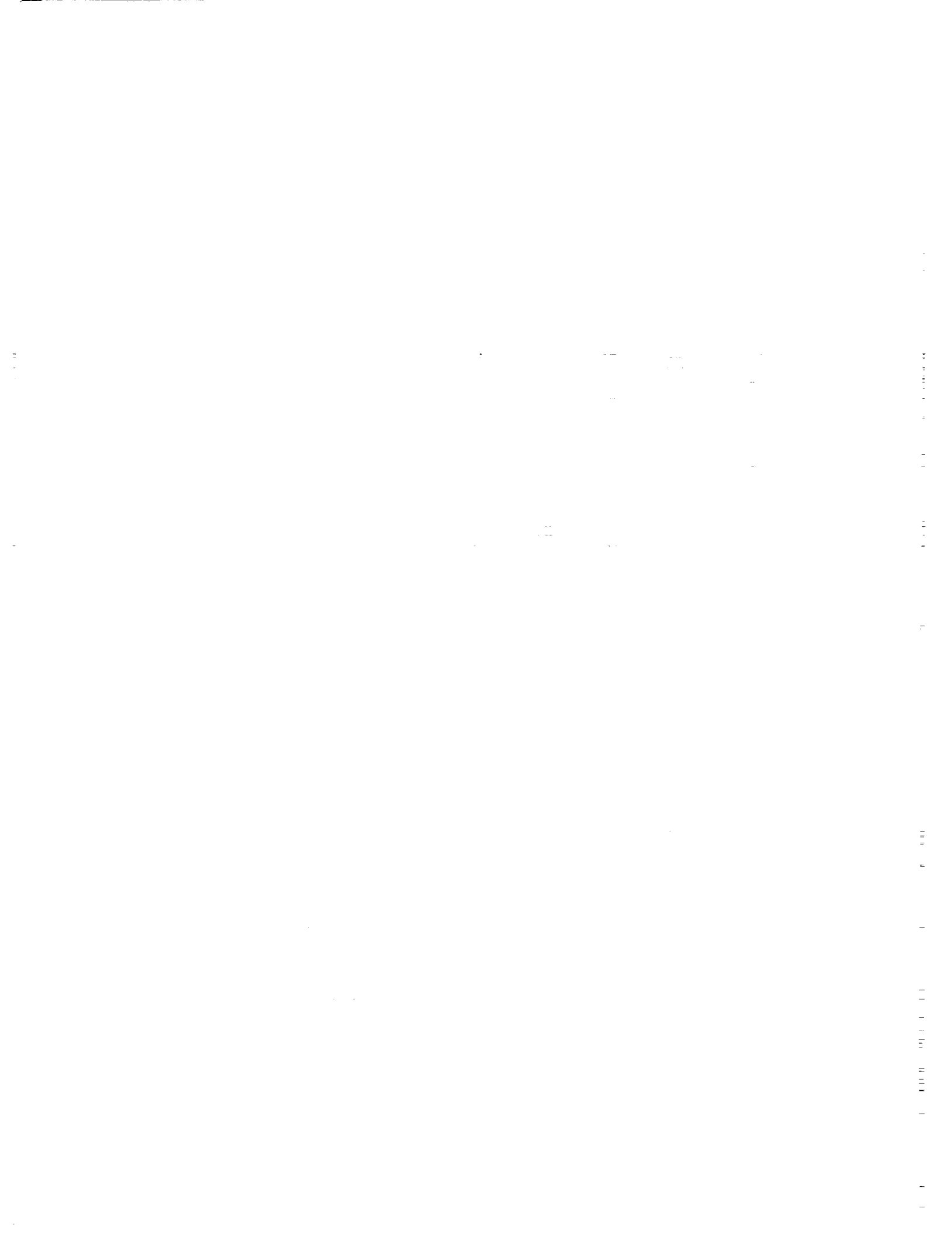

**Development of a Machine Vision Guidance System for
Automated Assembly of Space Structures**

Eric G. Cooper
Automation Technology Branch

P. Daniel Sydow
Spacecraft Structures Branch

N 9 2 - 2 7 7 7 5

Automated Structural Assembly Robot Vision

Objective:

Provide position verification of the node receptacle with respect to the end effector

Approach:

Fabricate custom camera/lighting hardware and adapt the 4 point target location algorithm developed in the Intelligent Systems Research Laboratory (ISRL)

Develop robust target discrimination techniques

Results:

Consistent and robust target identification and position estimation in the ASAL environment

Machine Vision Requirements

Camera and light assembly must be attached to robot end-effector

Enable the operator to monitor and provide assistance

Provide position information with no manipulator servoing to locate the target

Discriminate between similar targets within the field of view

Provide positional accuracy of at least 0.25 inches

Vision Hardware and Targets

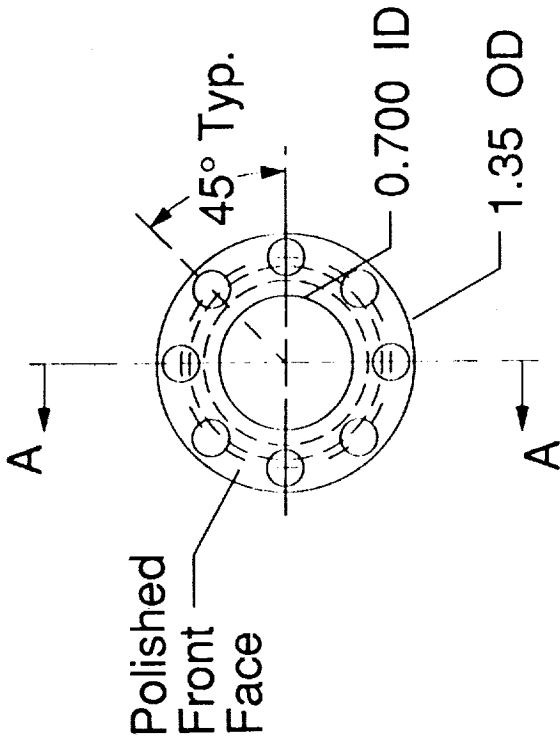

Ring Light Mount

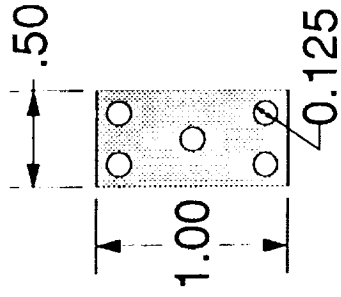

Old Target

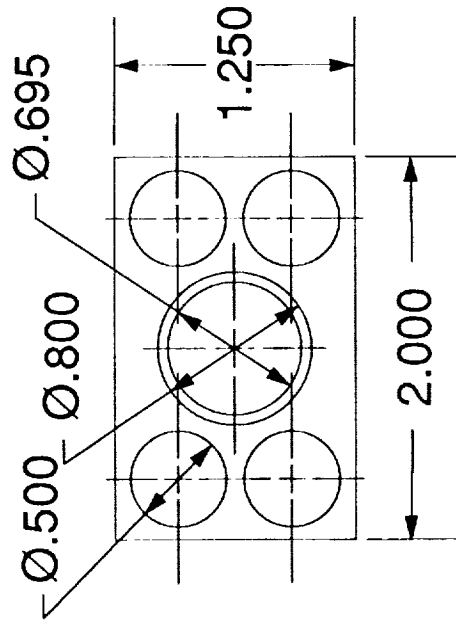

Focused Light Mount

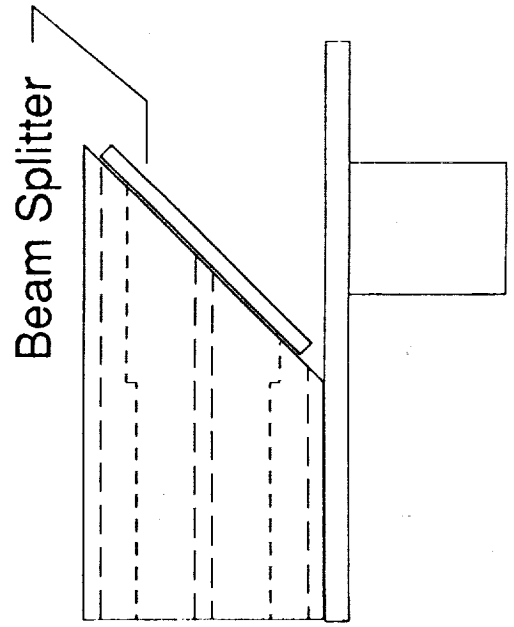

Beam Splitter

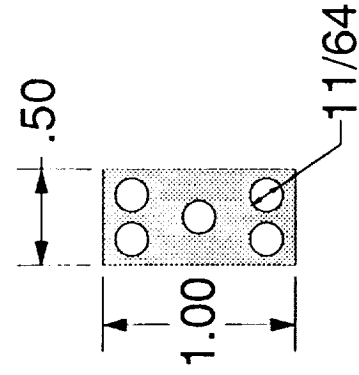

New Target

Reflective Efficiency

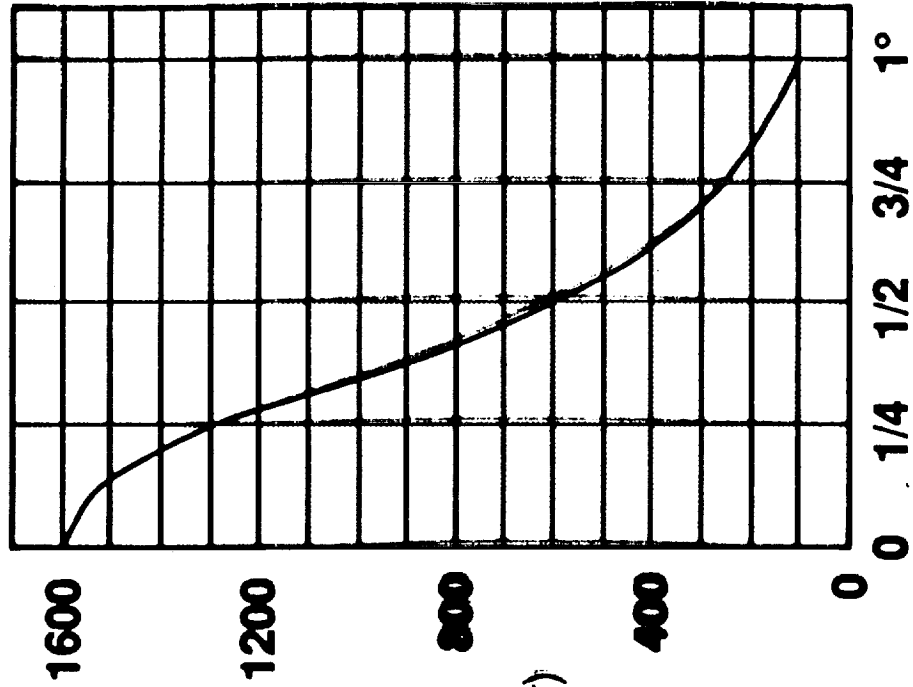

Luminance Factor

(Number of times brighter than a perfect white diffuser)

Observation Angle

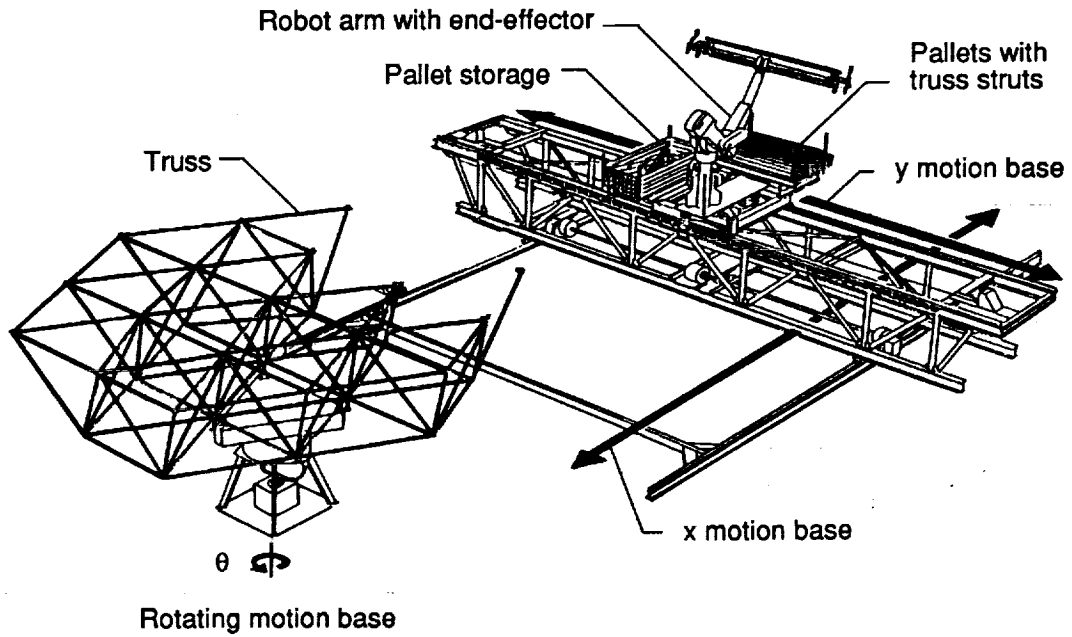

(a) Schematic of Automated Structural Assembly Laboratory.

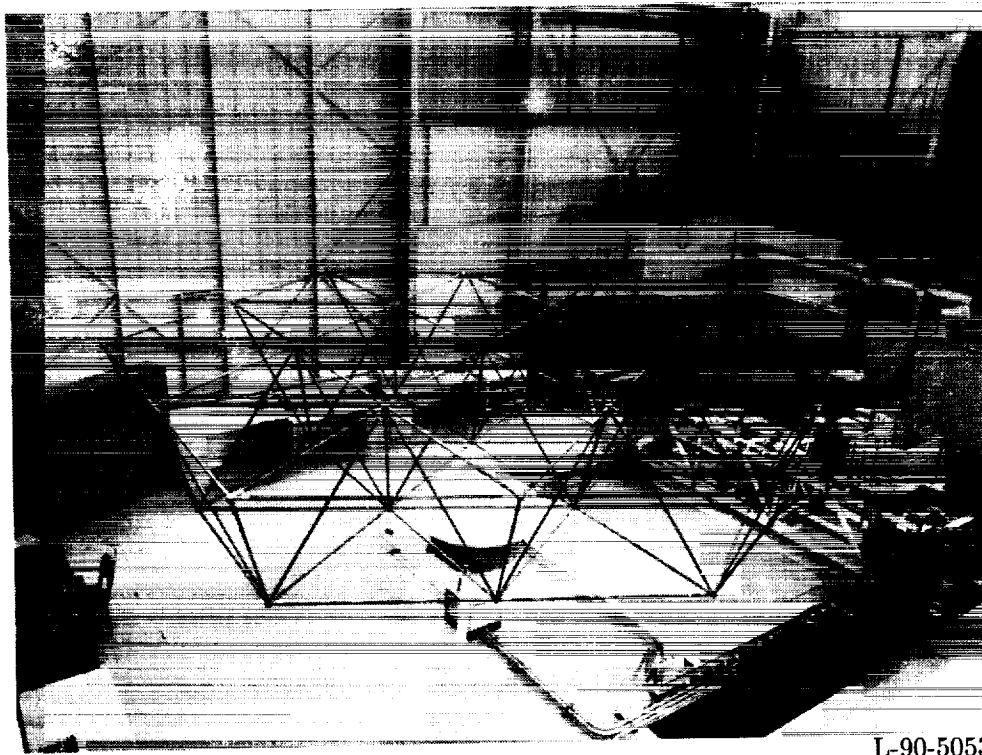

L-90-5053

(b) Hardware in Automated Structural Assembly Laboratory.

Figure 1. Automated Structural Assembly Laboratory.

Target Identification

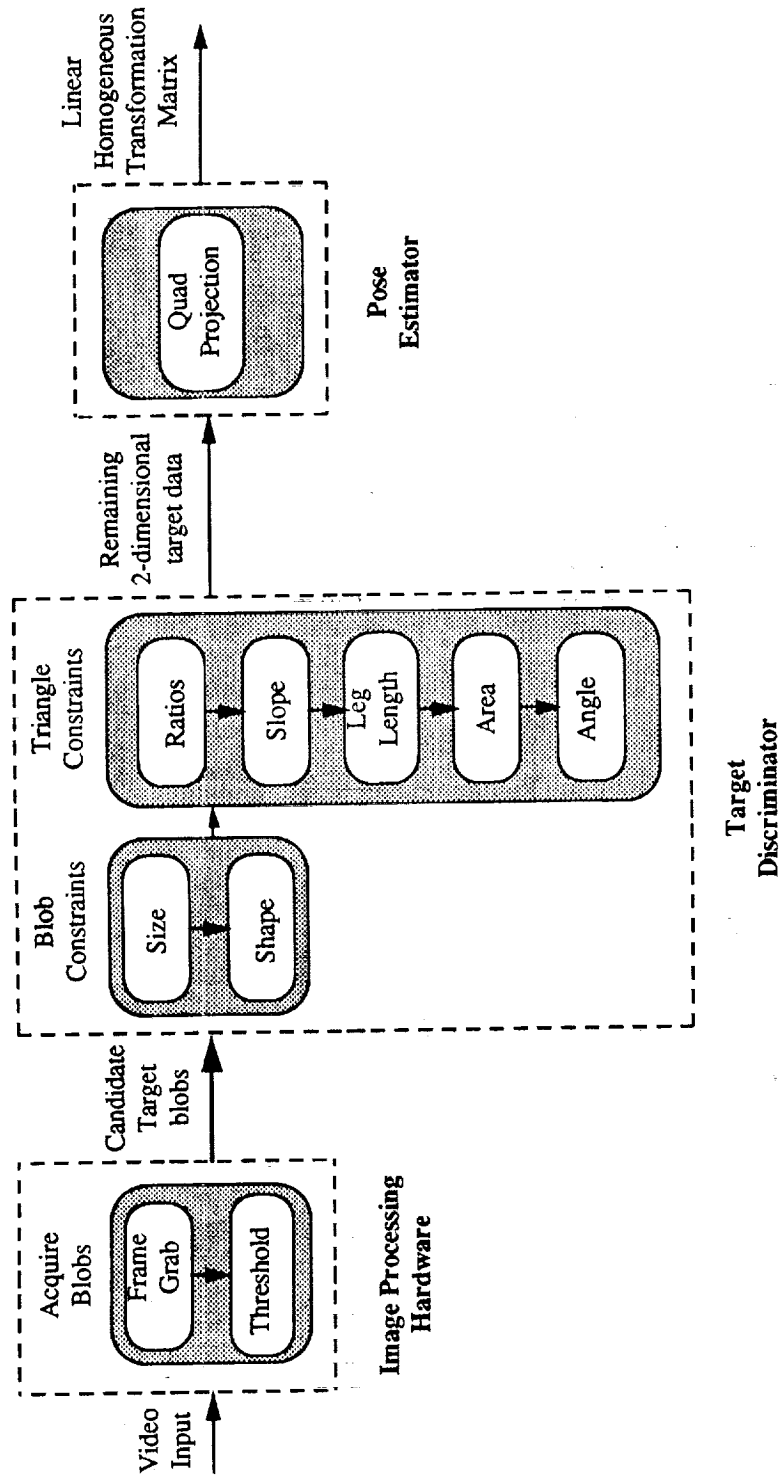

Pose Estimation Algorithms - Functional Description

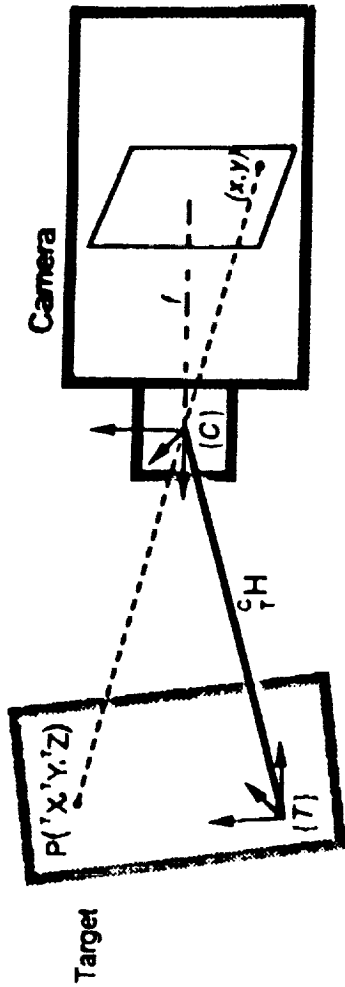

INPUT:

- Target points in target coordinate system $\{(x', y', z')\}$
- Corresponding image point projections $\{(x, y)\}$

PROCESSING:

- Algorithms differ, but all are based on the perspective projection equations:

$$x = f \frac{c_x x'}{z'}, \quad y = f \frac{c_y y'}{z'}$$
- where
$$\begin{bmatrix} c_x \\ c_y \\ c_z \end{bmatrix} = {}^C_H \begin{bmatrix} x' \\ y' \\ z' \end{bmatrix}$$
- Given a sufficient number of feature points, the pose can be determined
- Additional points increase the accuracy of the pose estimation

OUTPUT:

- Target pose with respect to the camera frame; i.e., C_H

Triangle Constraints

- Ratios
- Slope
- Leg Length
- Area
- Angle

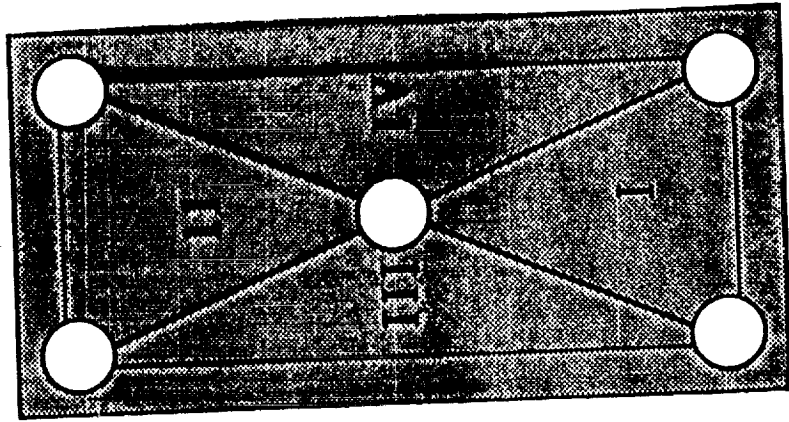

5 Point Target

ORIGINAL PAGE
BLACK AND WHITE PHOTOGRAPH

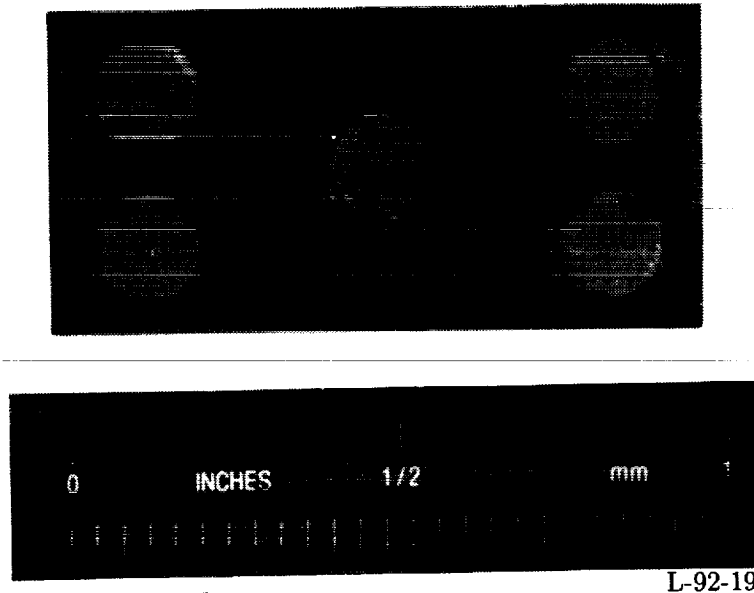

Figure 2. Joint receptacle target.

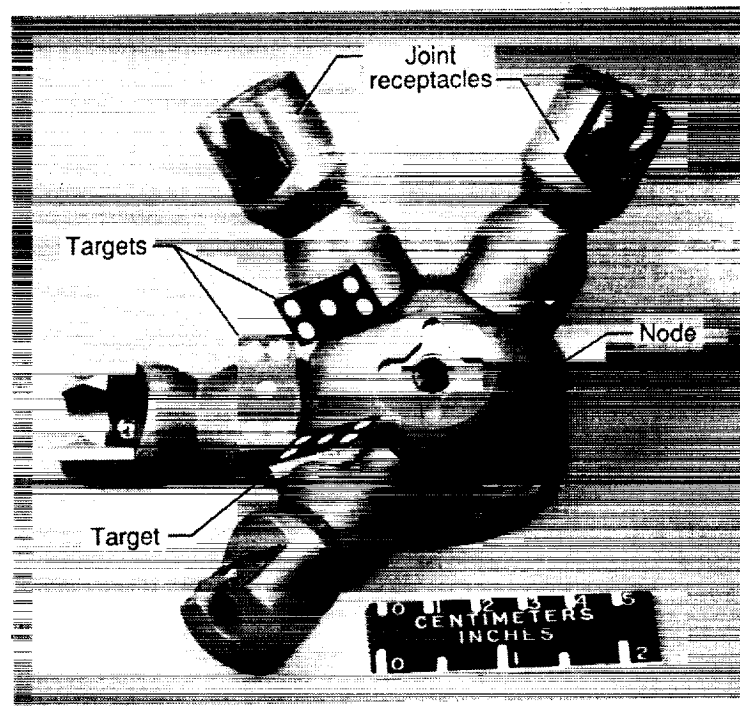
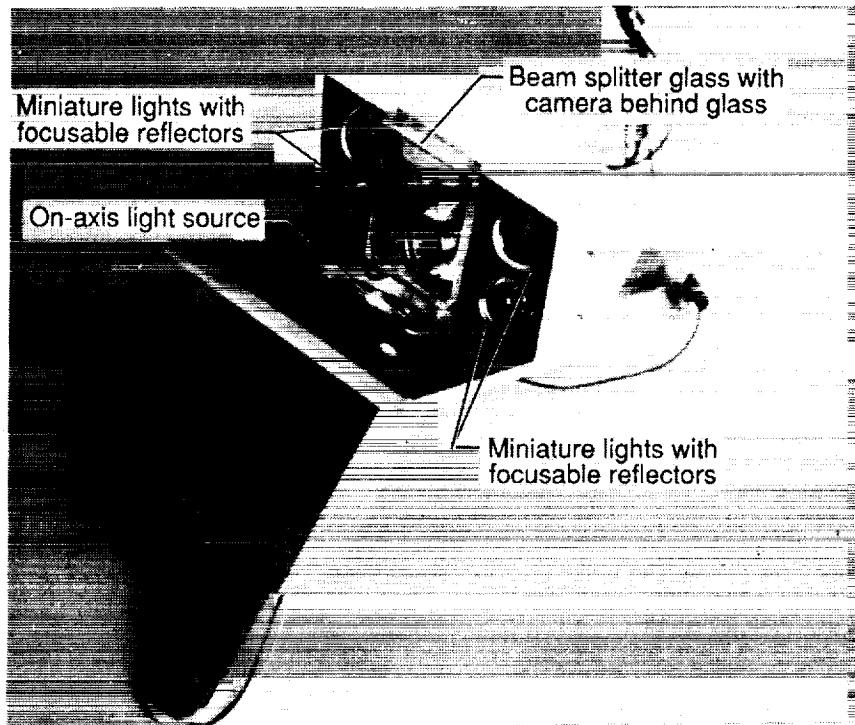
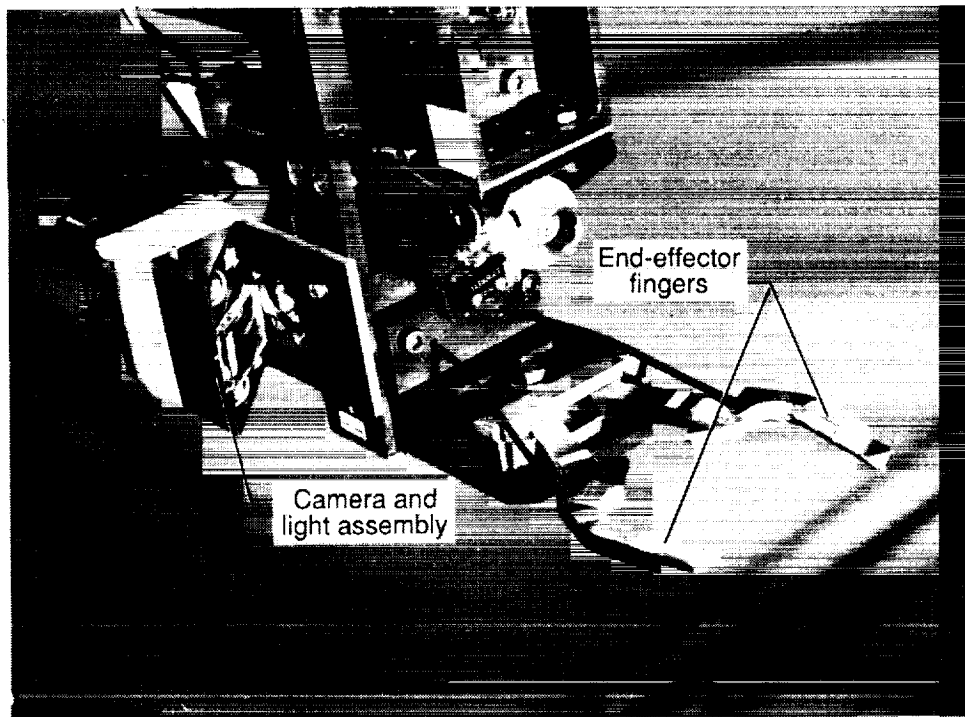

Figure 3. Truss node with joint receptacle targets.



L-91-6331

Figure 4. Camera and light assembly.



L-91-05738

Figure 5. End-effector mounted camera and light assembly.

ORIGINAL PAGE
BLACK AND WHITE PHOTOGRAPH

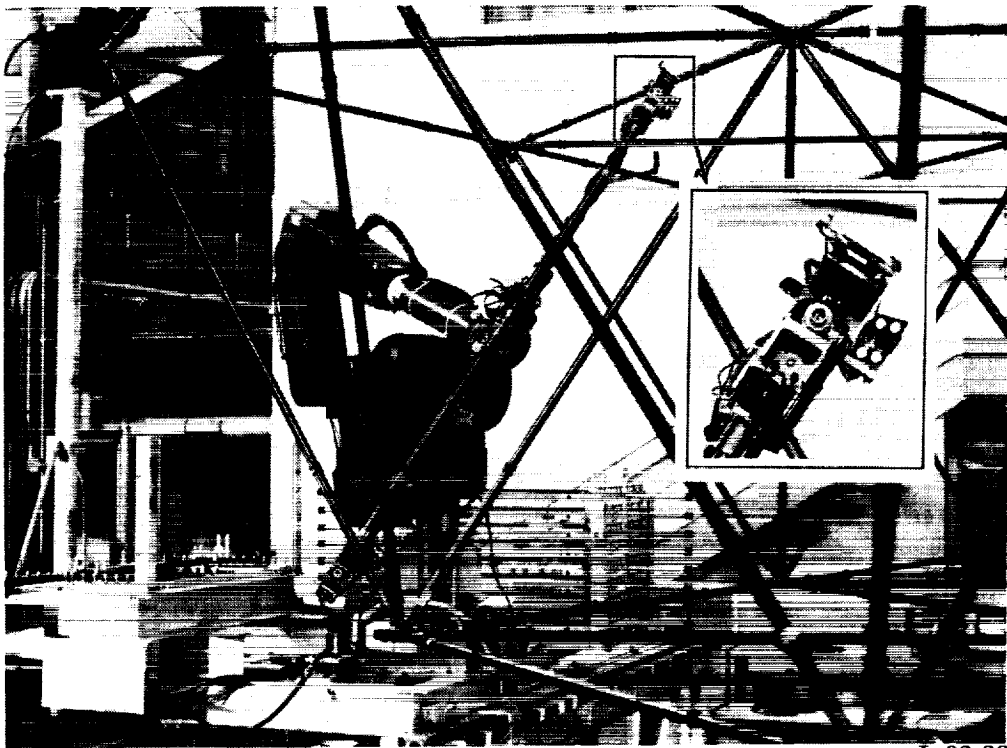

L-92-20

Figure 6. Robot arm at typical vision approach point.

ORIGINAL PAGE
BLACK AND WHITE PHOTOGRAPH

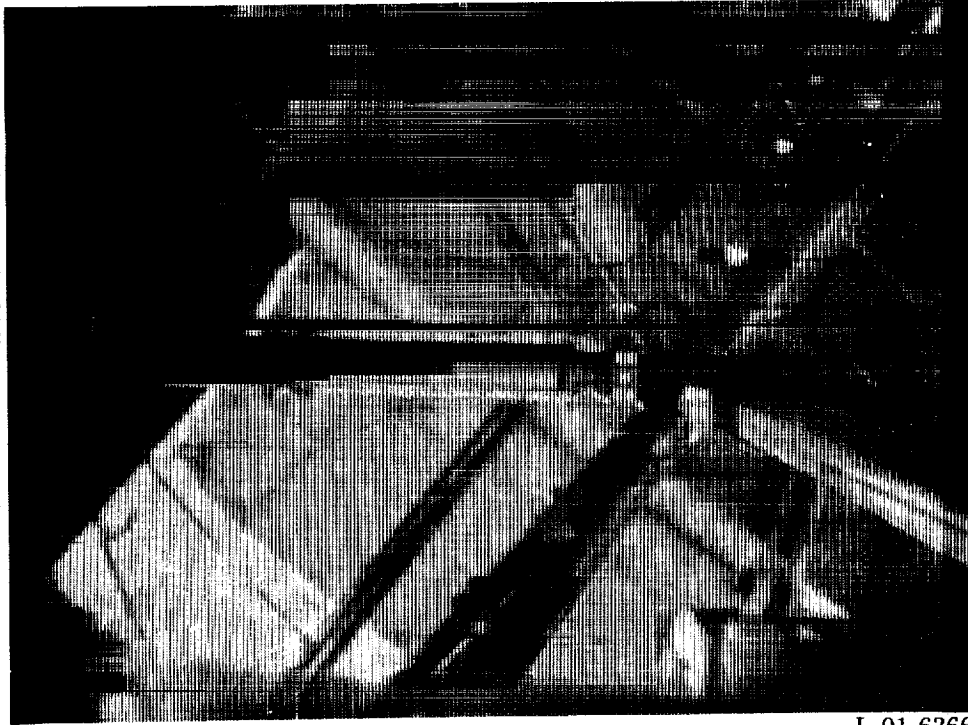

L-91-6366

(a) Vision system view at range of ≈ 24 in.

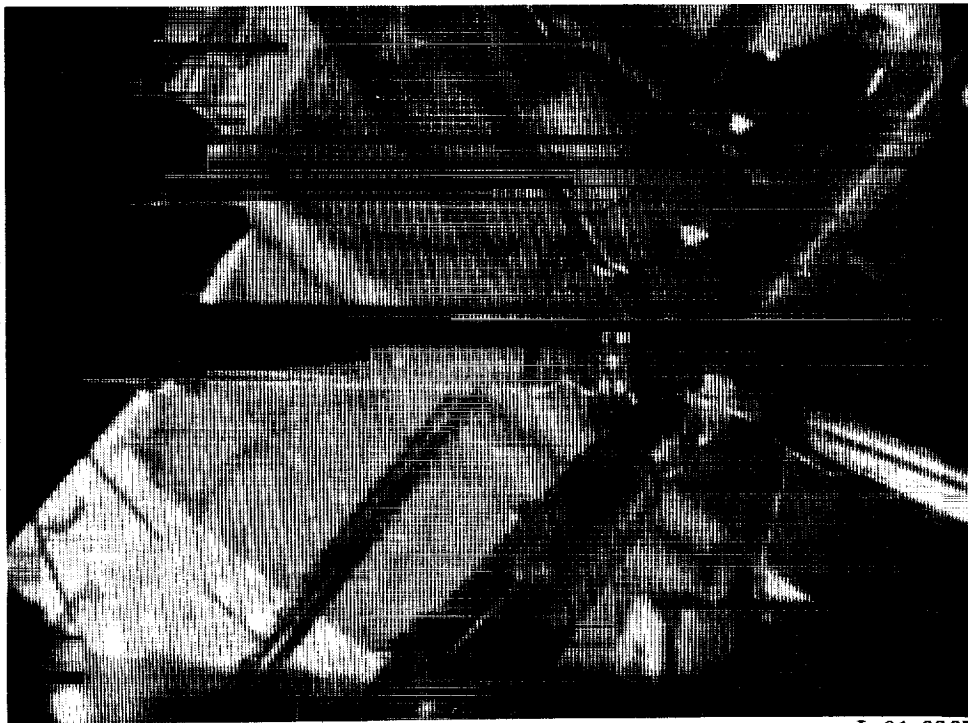

L-91-6367

(b) Vision system view at range of ≈ 18 in.

Figure 8. Typical incremental approach.

ORIGINAL PAGE
BLACK AND WHITE PHOTOGRAPH



L-91-6368

(c) Vision system at range of ≈ 12 in.

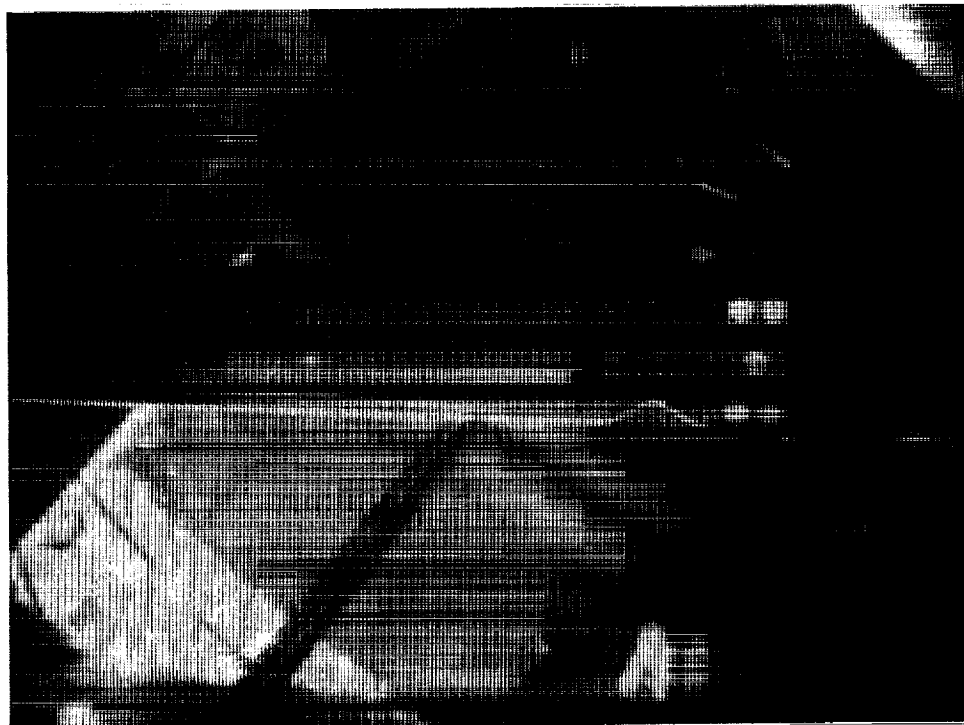

L-91-6369

(d) Vision system view at range of ≈ 6 in.

Figure 8. Concluded.

ORIGINAL PAGE
BLACK AND WHITE PHOTOGRAPH

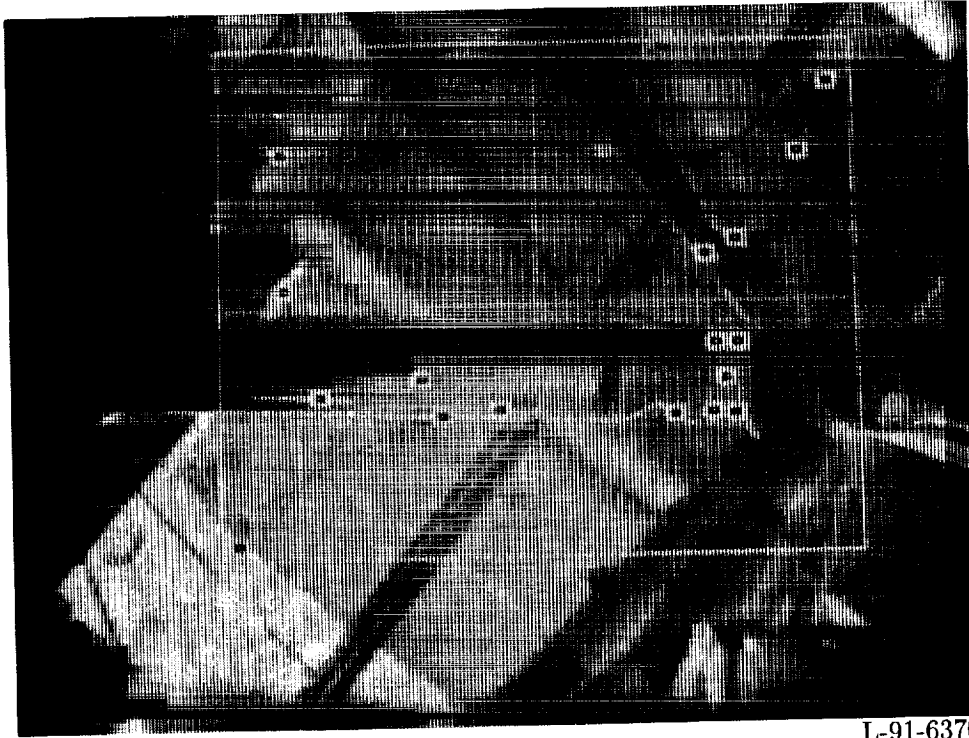

(a) Processed image after blob-size constraint applied.

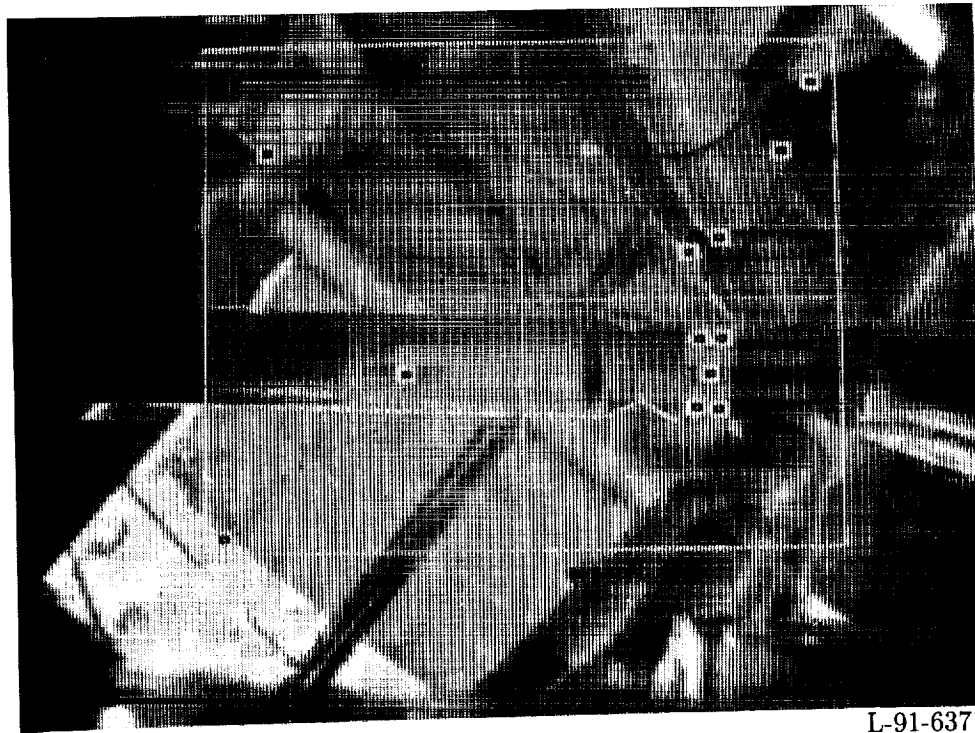

(b) Processed image after blob shape constraint applied.

Figure 9. Sequential discrimination of target from background.

ORIGINAL PAGE
BLACK AND WHITE PHOTOGRAPH



L-91-6372

(c) Processed image after exhaustive triangle generation.

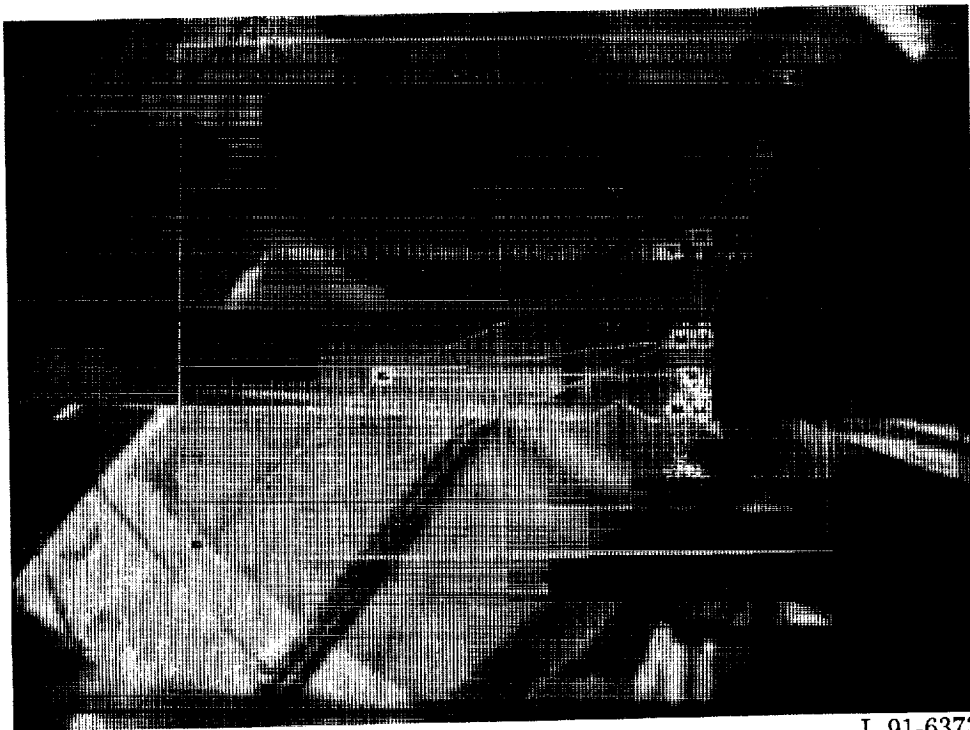

L-91-6373

(d) Processed image after application of ratio test equations.

Figure 9. Continued.

ORIGINAL PAGE
BLACK AND WHITE PHOTOGRAPH

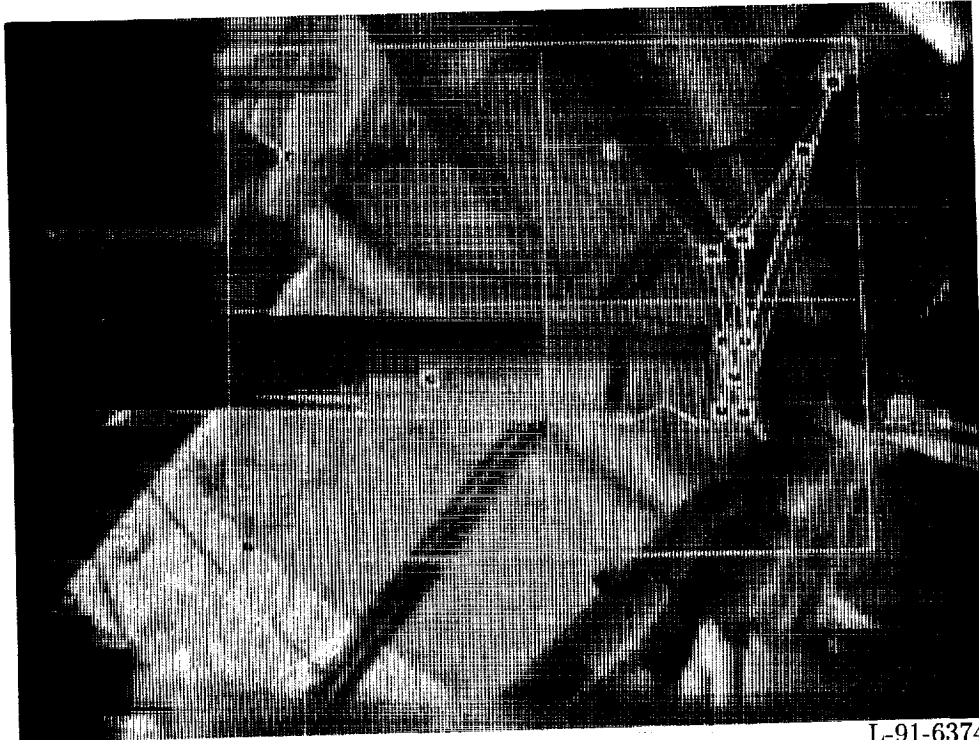

L-91-6374

(e) Processed image after triangle slope constraint applied.

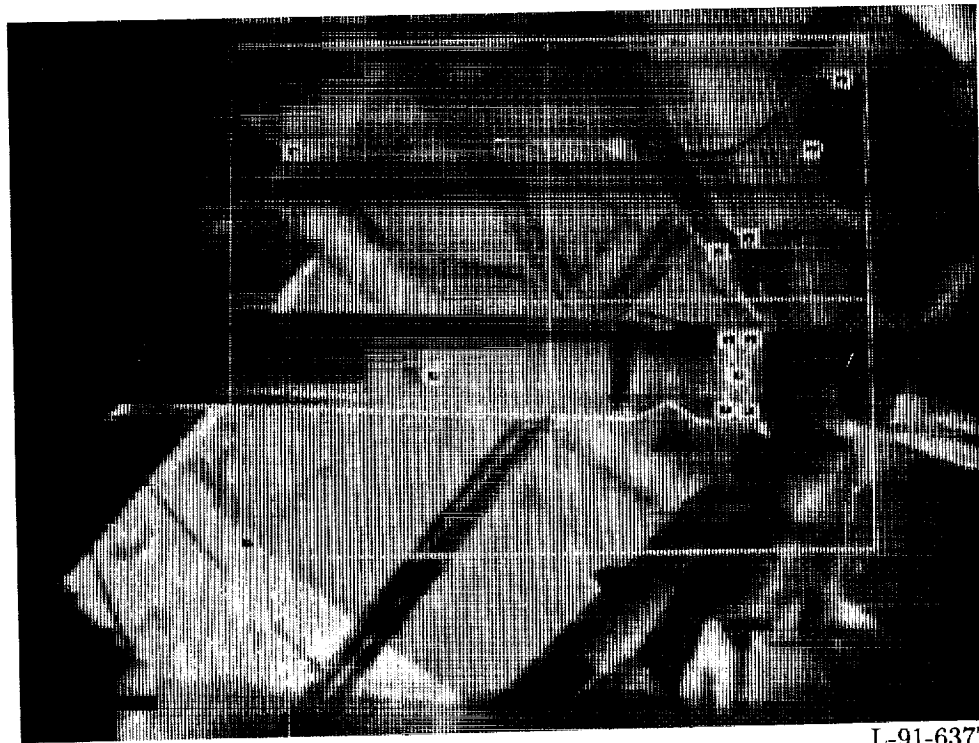

L-91-6377

(f) Processed image after length, area, and angle constraints applied.

Figure 9. Continued.

ORIGINAL PAGE
BLACK AND WHITE PHOTOGRAPH

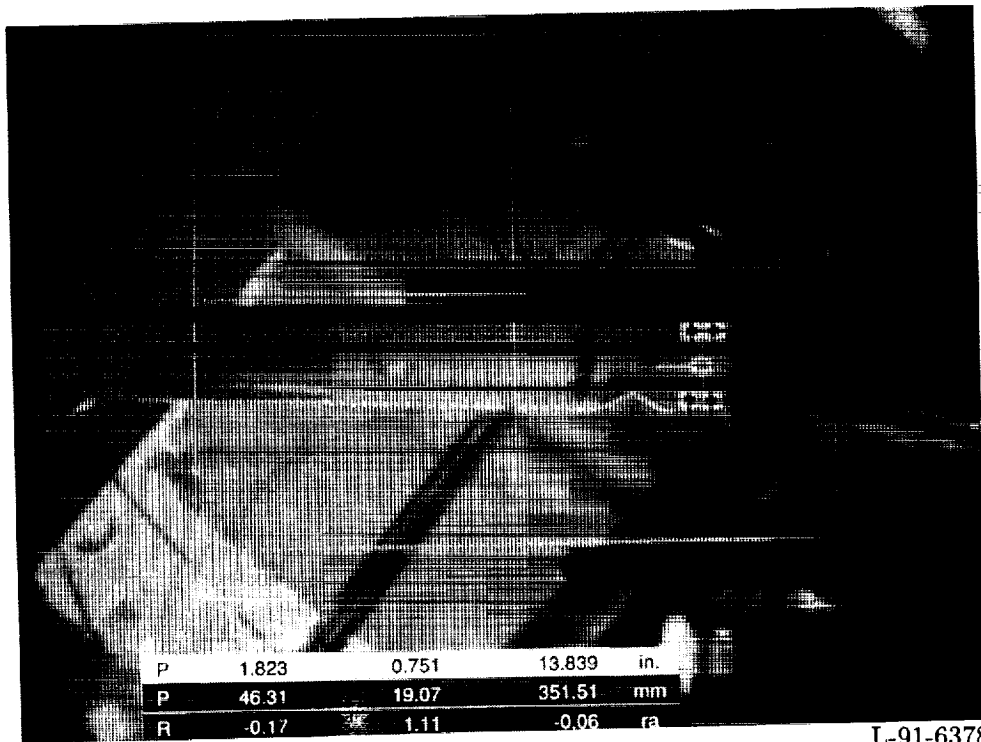

L-91-6378

(g) Processed image after target lock-on and pose estimation. Top two lines of key give position vector in inches and millimeters, respectively. The bottom line gives rotation vector in radians.

Figure 9. Concluded.

Camera Axis

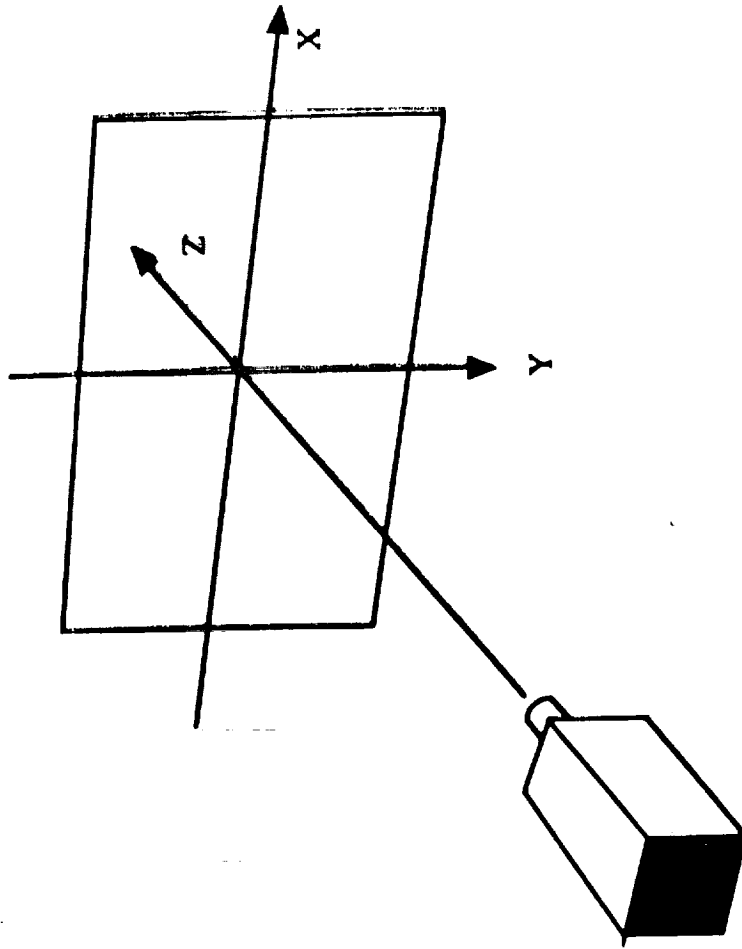

Vision System Results from Optical Bench Tests (X Axis)

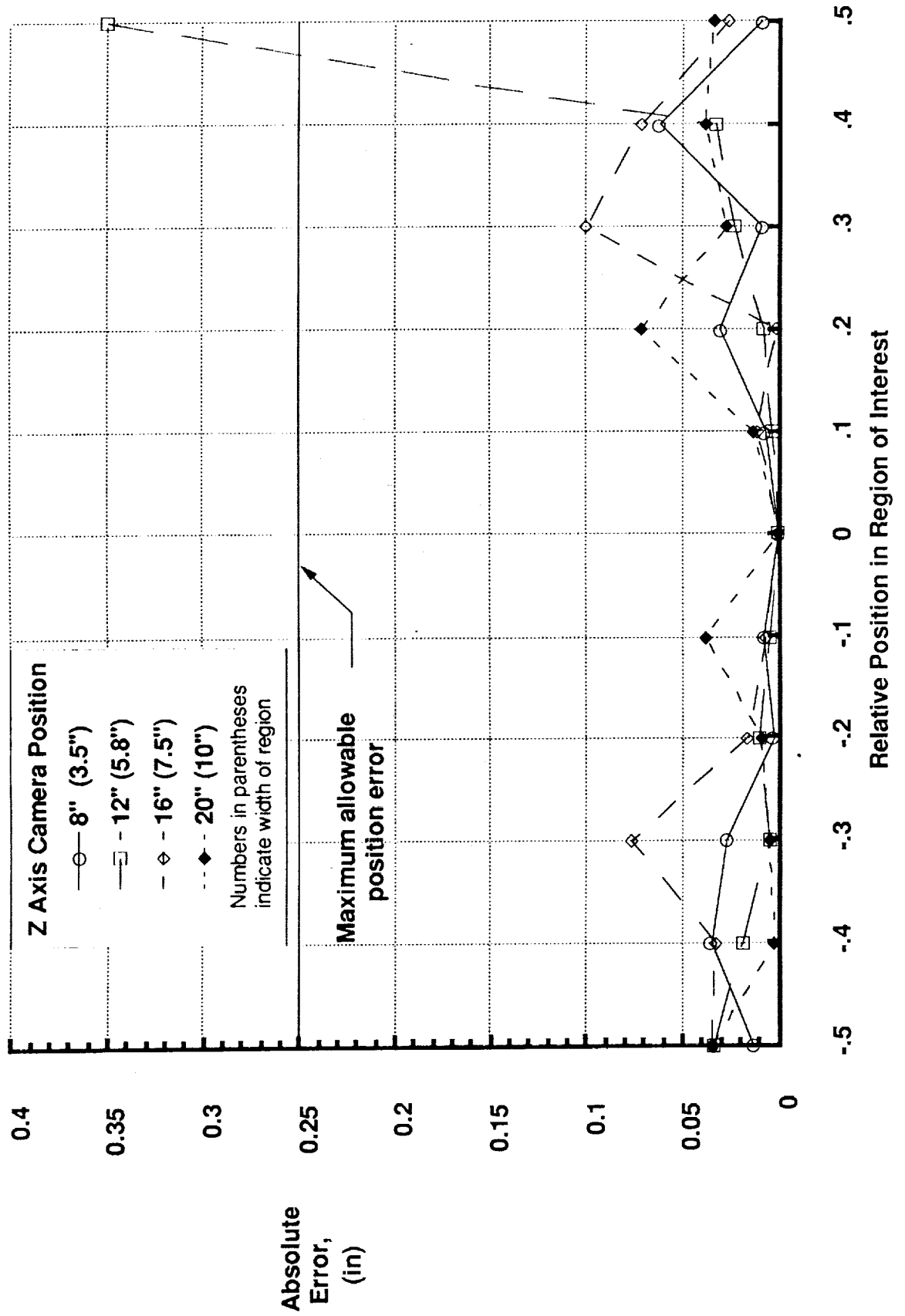

Vision System Results from Optical Bench Tests (Y Axis)

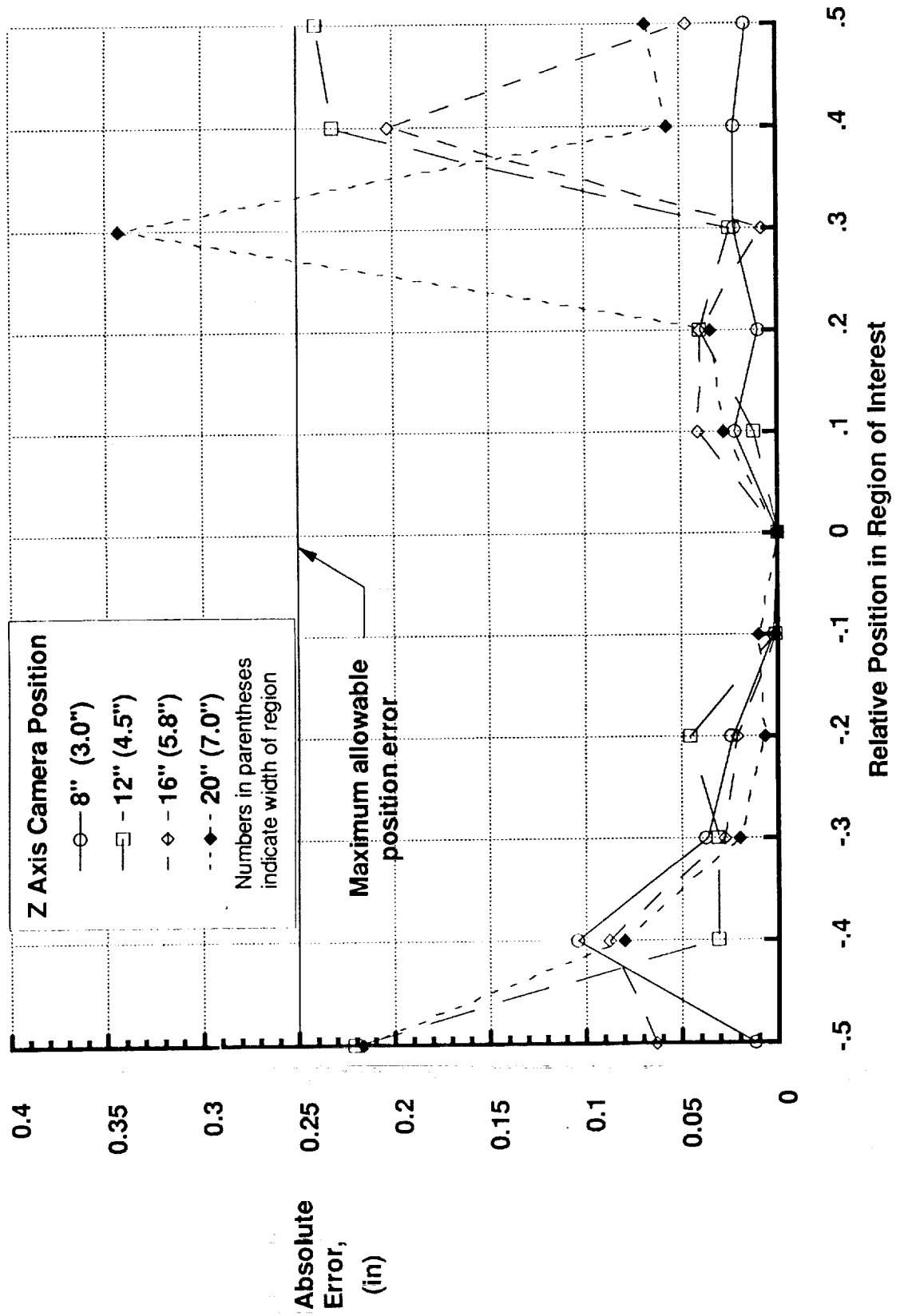

Vision System Results from Optical Bench Tests (Z Axis)

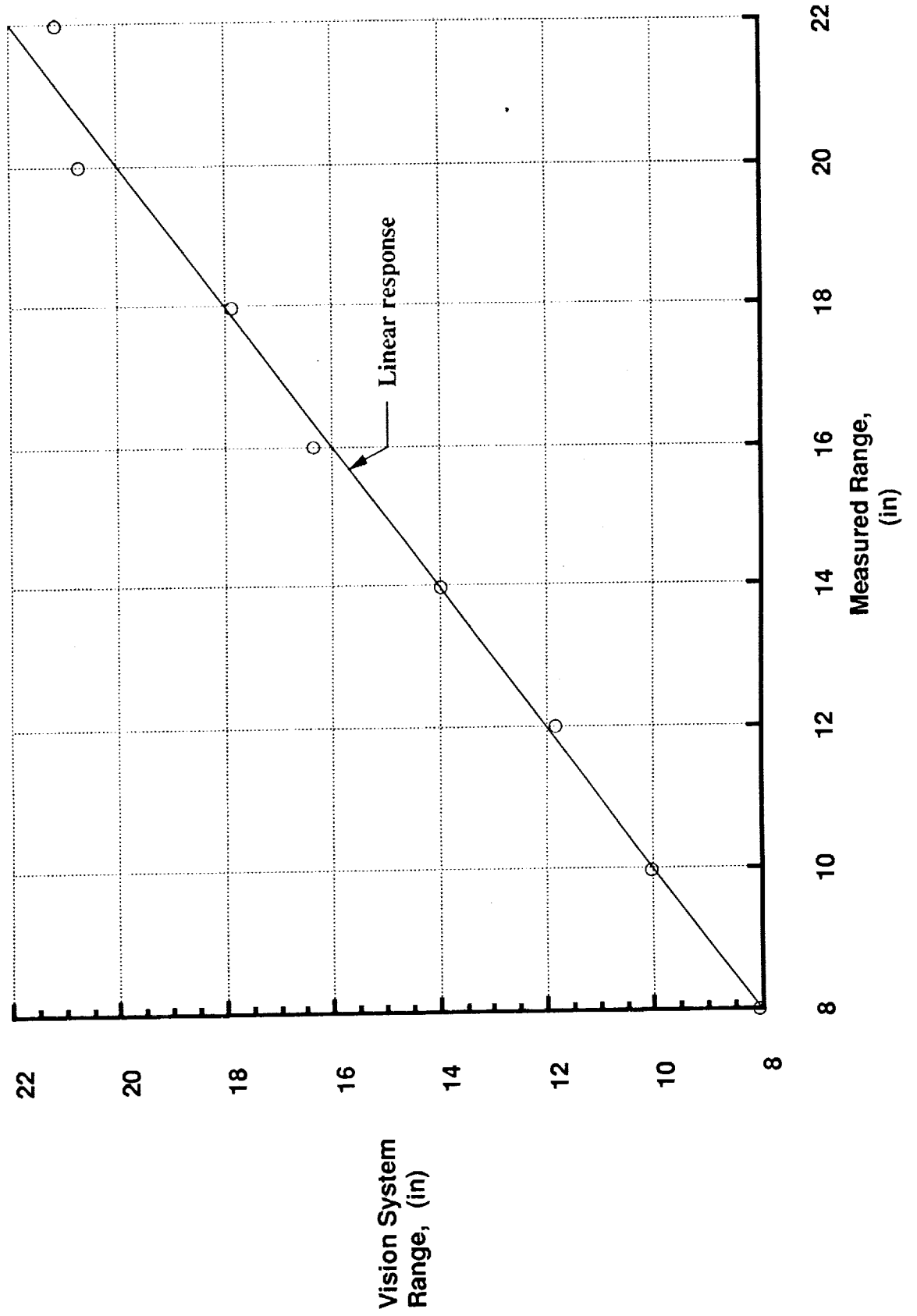

Future Work

Implement remote light control to both enhance automation and provide an additional tool for operator assistance

Fabricate a camera alignment fixture

Demonstrate vision control on a complete assembly / disassembly of the ASAL truss structure

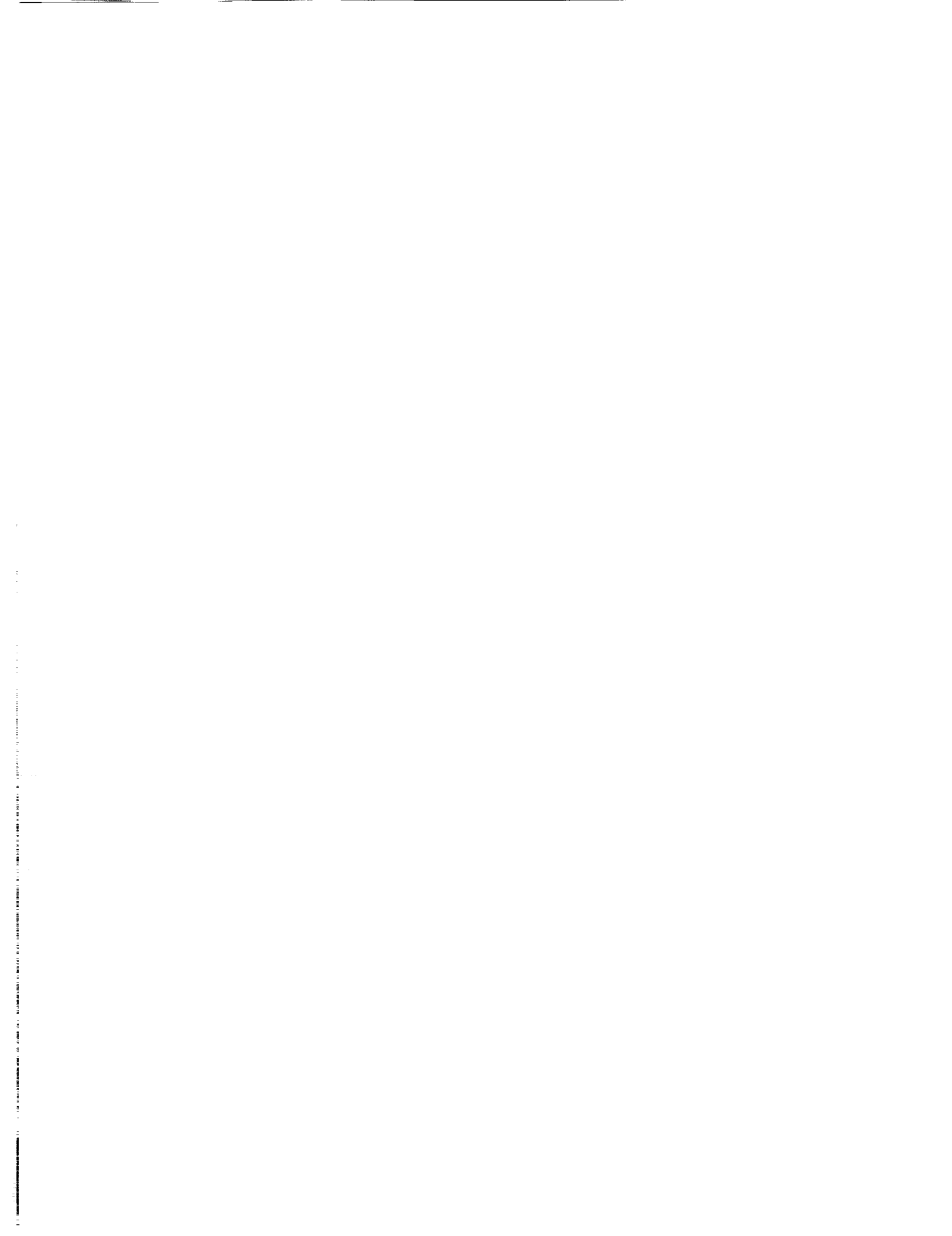

N 9 2 - 2 7 7 7 6

**END-EFFECTOR
MICROPROCESSOR**

b y

WILLIAM R. DOGGETT

Why?

- **require one interface to all end-effectors in ASAL**
 - **each with unique control and sensing requirements**
 - **common command interface**
- **require concurrent capability**
- **must reduce number of signal lines required to operate each end-effector**
- **desire to relieve merlin robot of end-effector responsibility**

AUTOMATED STRUCTURES ASSEMBLY FACILITY

CURRENT CONTROL HIERARCHY

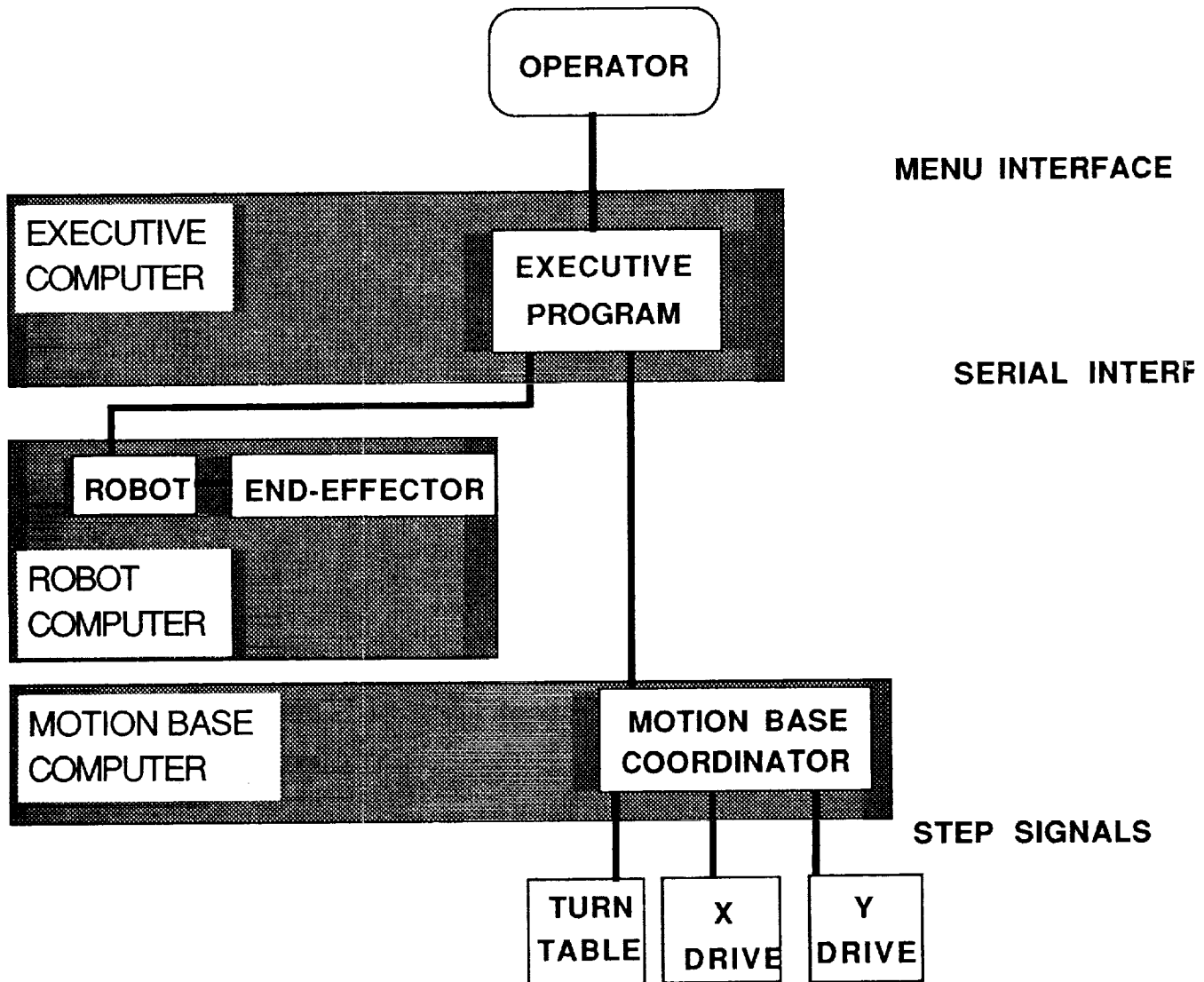

**AUTOMATED STRUCTURES ASSEMBLY FACILITY
PURPOSED CONTROL HIERARCHY**

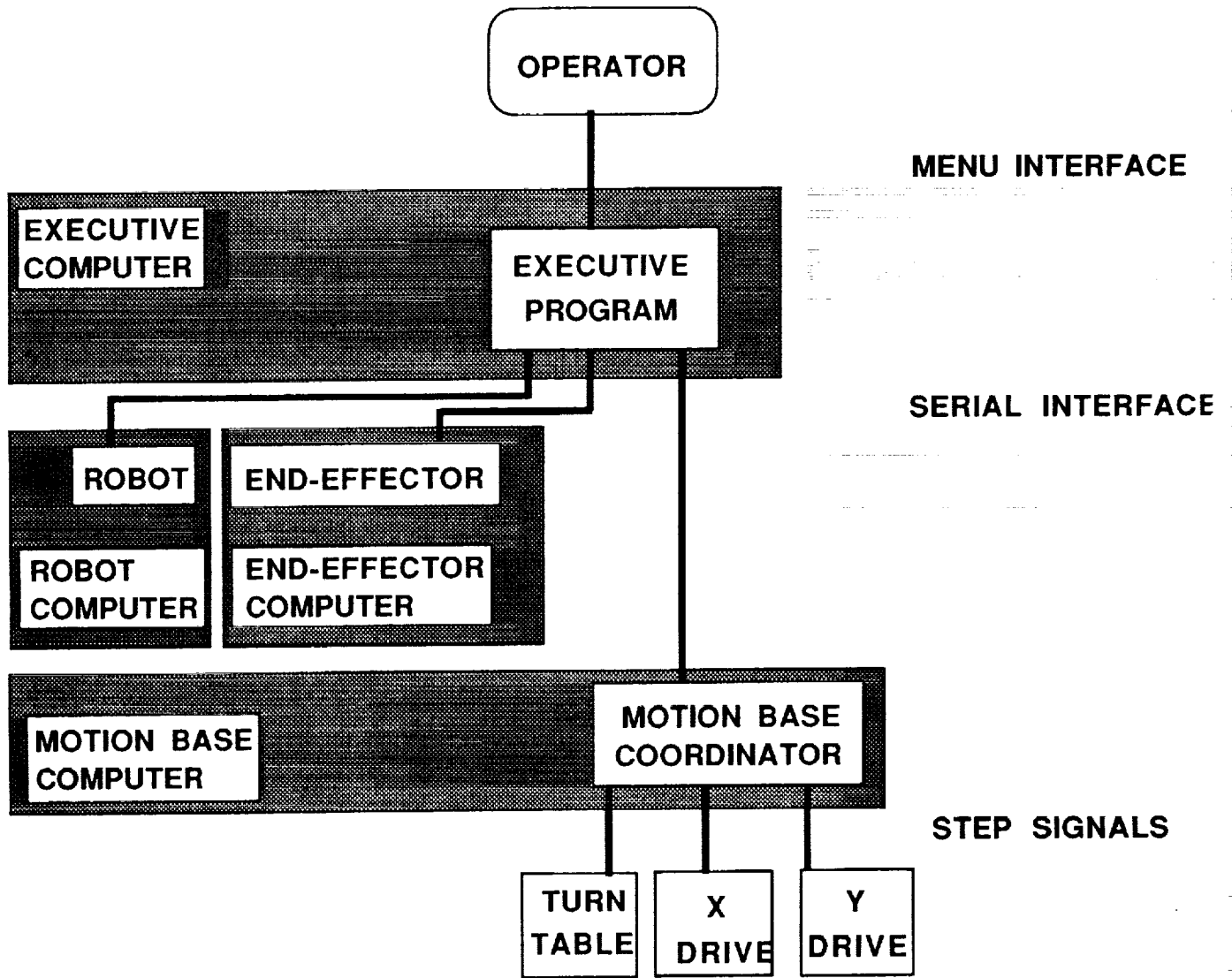

END-EFFECTOR SOFTWARE STATE TRANSITION DIAGRAM

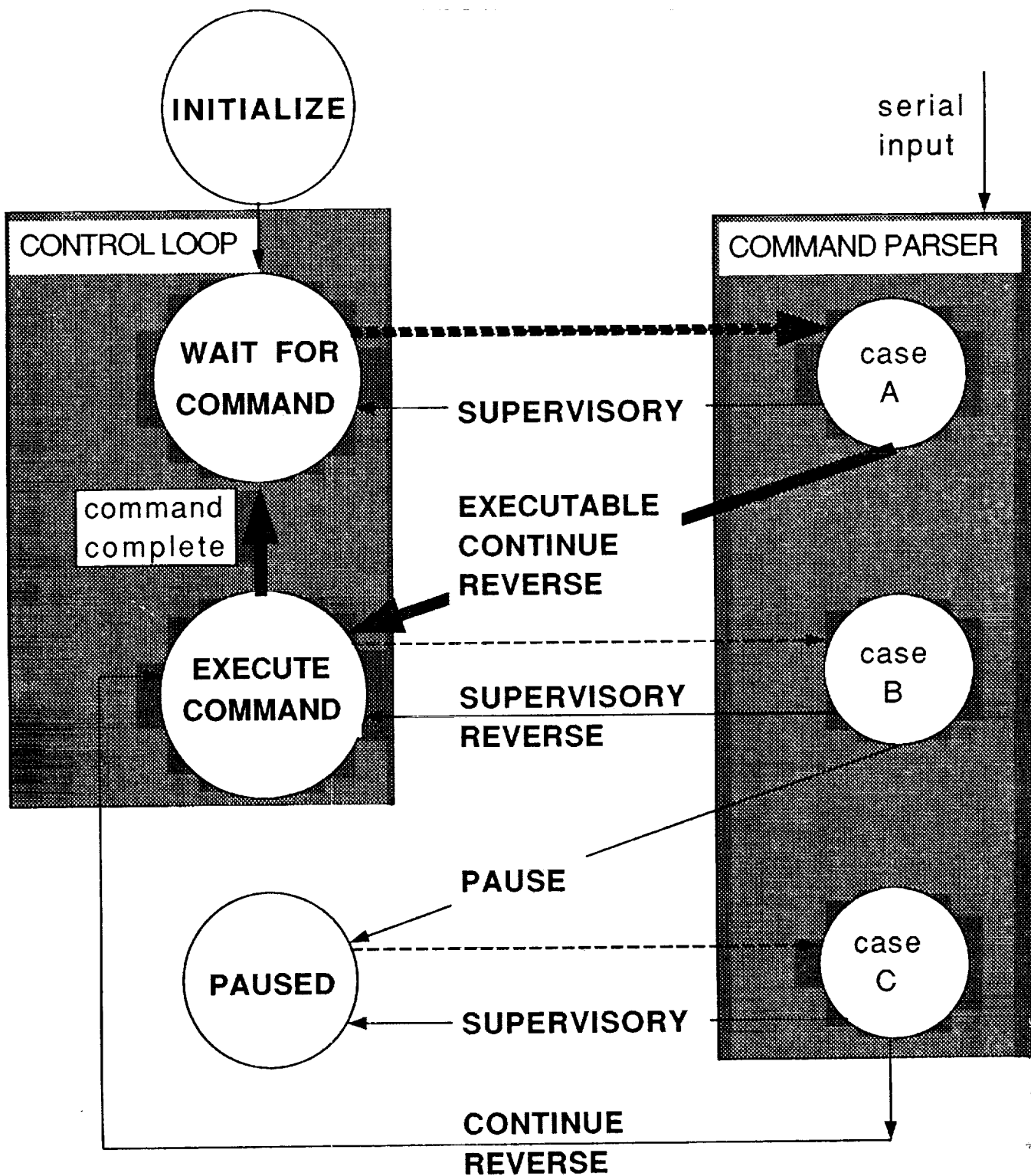

LEGEND

- dashed lines indicate interrupts
- bold lines indicate normal operation

BLOCK DIAGRAM FOR IDEAL INSTALL COMPOSITE

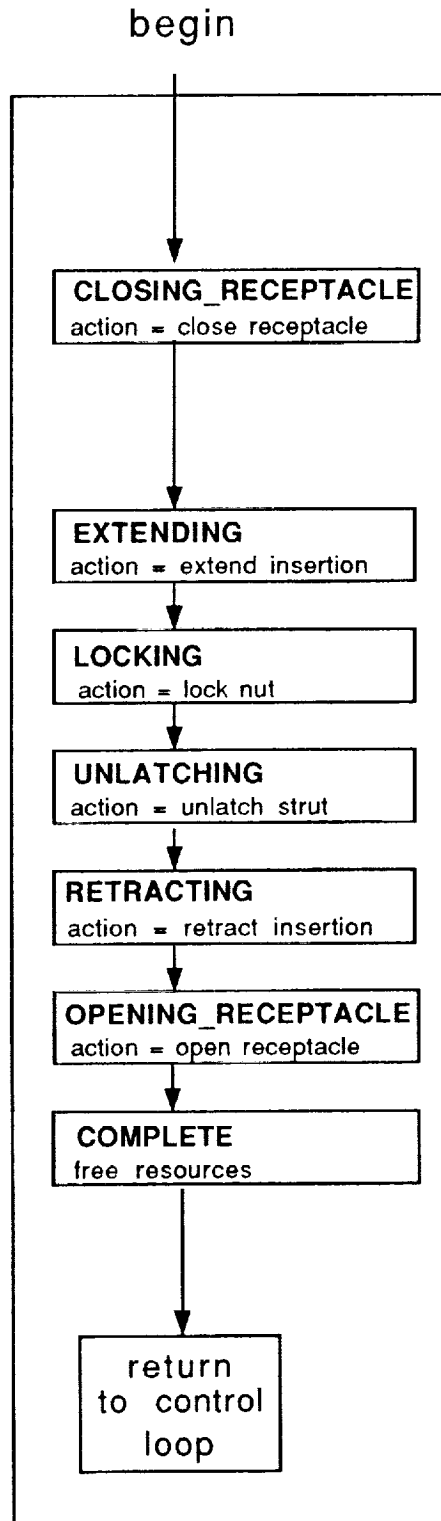

BLOCK DIAGRAM FOR INSTALL COMPOSITE

LEGEND

BOLD software states

ITALIC function names

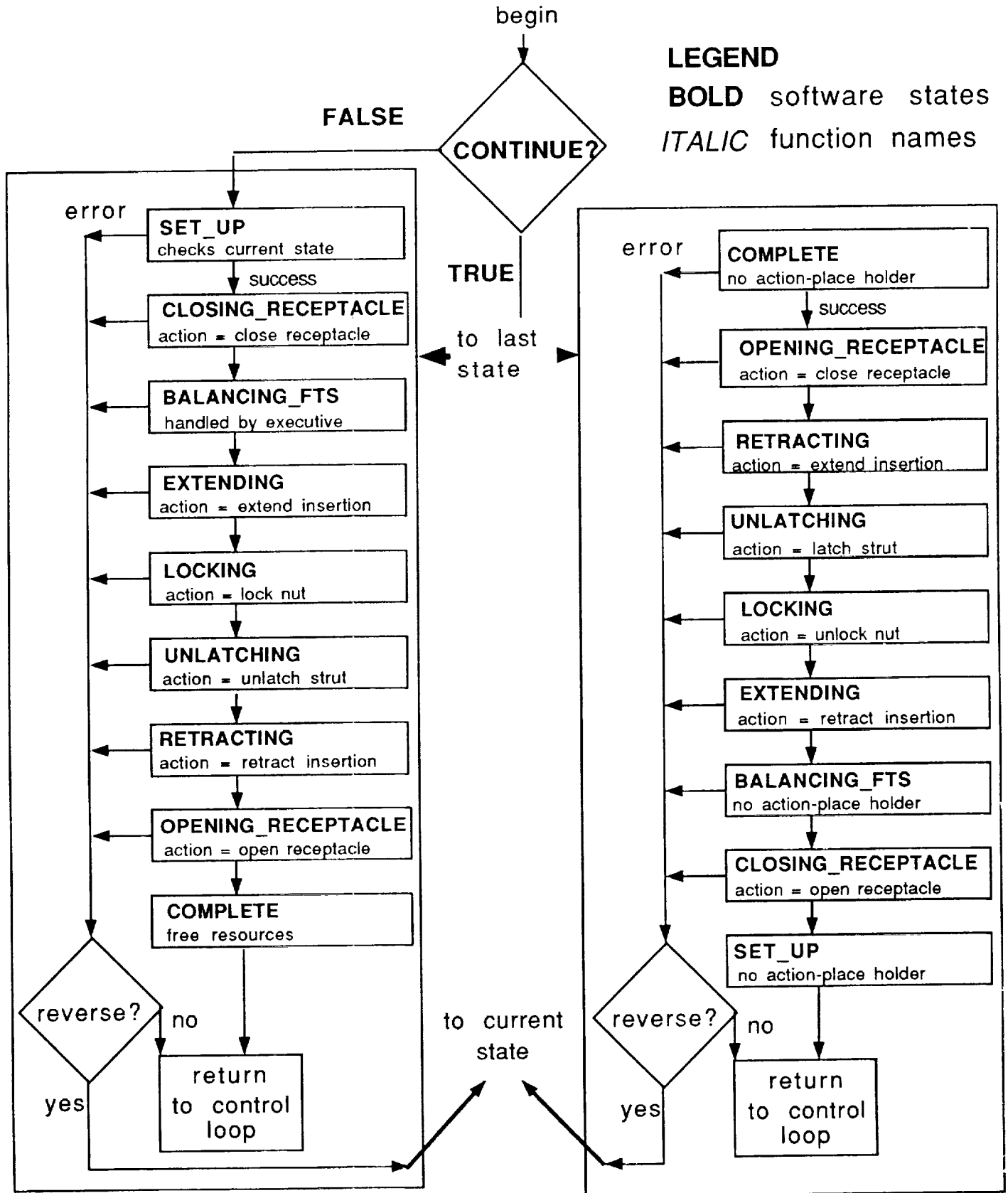

INSTALL

INSTALL_REVERSE

CONCLUSIONS

IMPROVED MODULARITY

CONSISTENT INTERFACE TO THE 3 END-EFFECTORS

SUPPORT FOR CONCURRENT OPERATIONS

SUPPORT FOR PAUSE/REVERSE AT ANYTIME

SUPPORT FOR OPERATOR OVERRIDE

POTENTIAL FOR INCREASED RELIABILITY

**Panel Installation Development
in
Automated Structures Assembly Lab**

N 9 2 - 2 7 7 7 7

Cuong Quach

Design Requirements for Panel Installation Process

- **High packing efficiency of panels in canister imparative**
- **Panels must fit into existing truss hardware with minimum modification to nodes.**
- **The inter-panel gap minimized to about .15 in.**
- **Minimize the number of mechanisms on the end effector**
- **End effector must be attachable to current robot**

ORIGINAL PAGE
BLACK AND WHITE PHOTOGRAPH

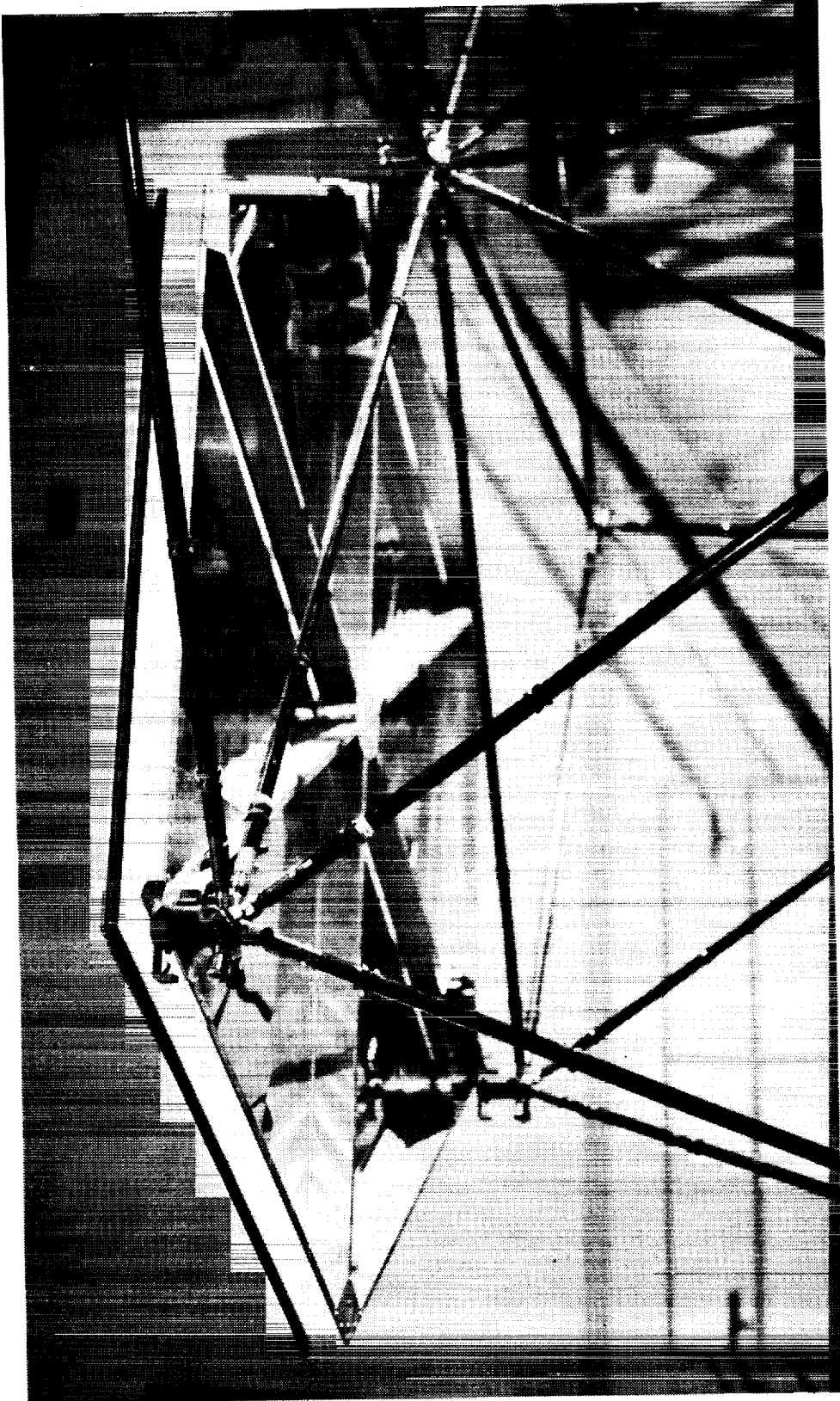

Panel latches to truss via adaptors

ORIGINAL PAGE
BLACK AND WHITE PHOTOGRAPH

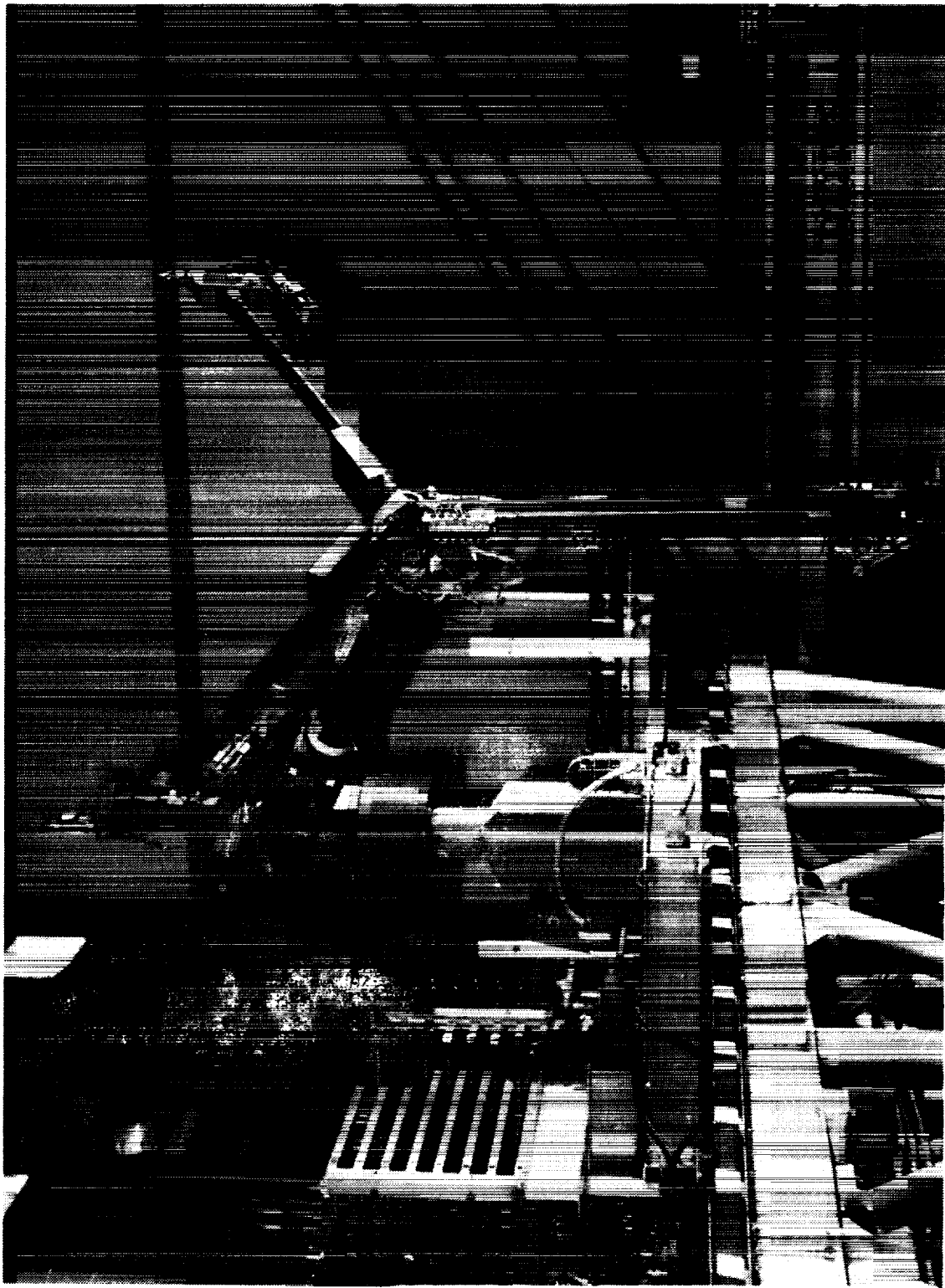

Panel end effector

ORIGINAL PAGE
BLACK AND WHITE PHOTOGRAPH

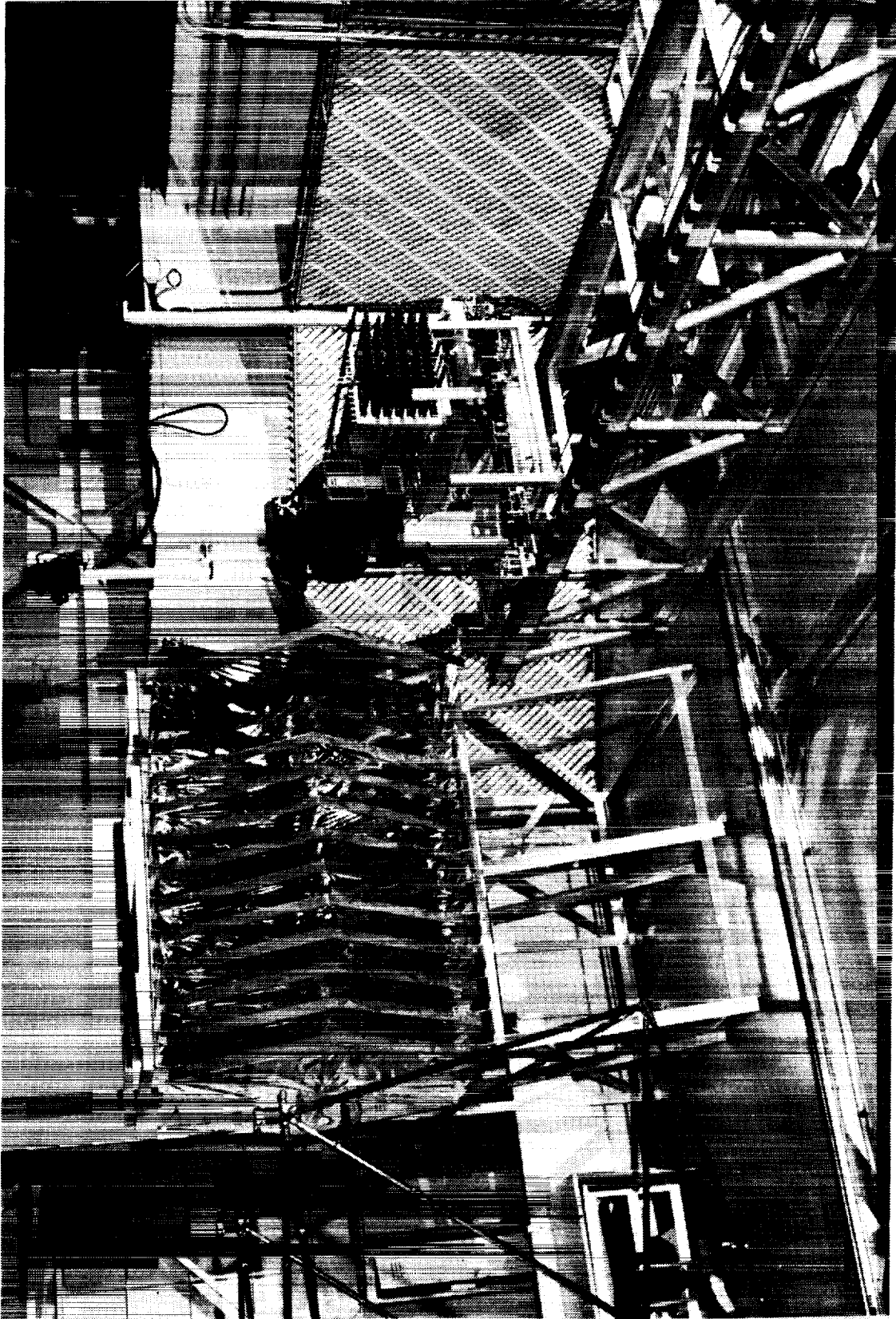

Arm retrieving panel from canister

ORIGINAL PAGE
BLACK AND WHITE PHOTOGRAPH

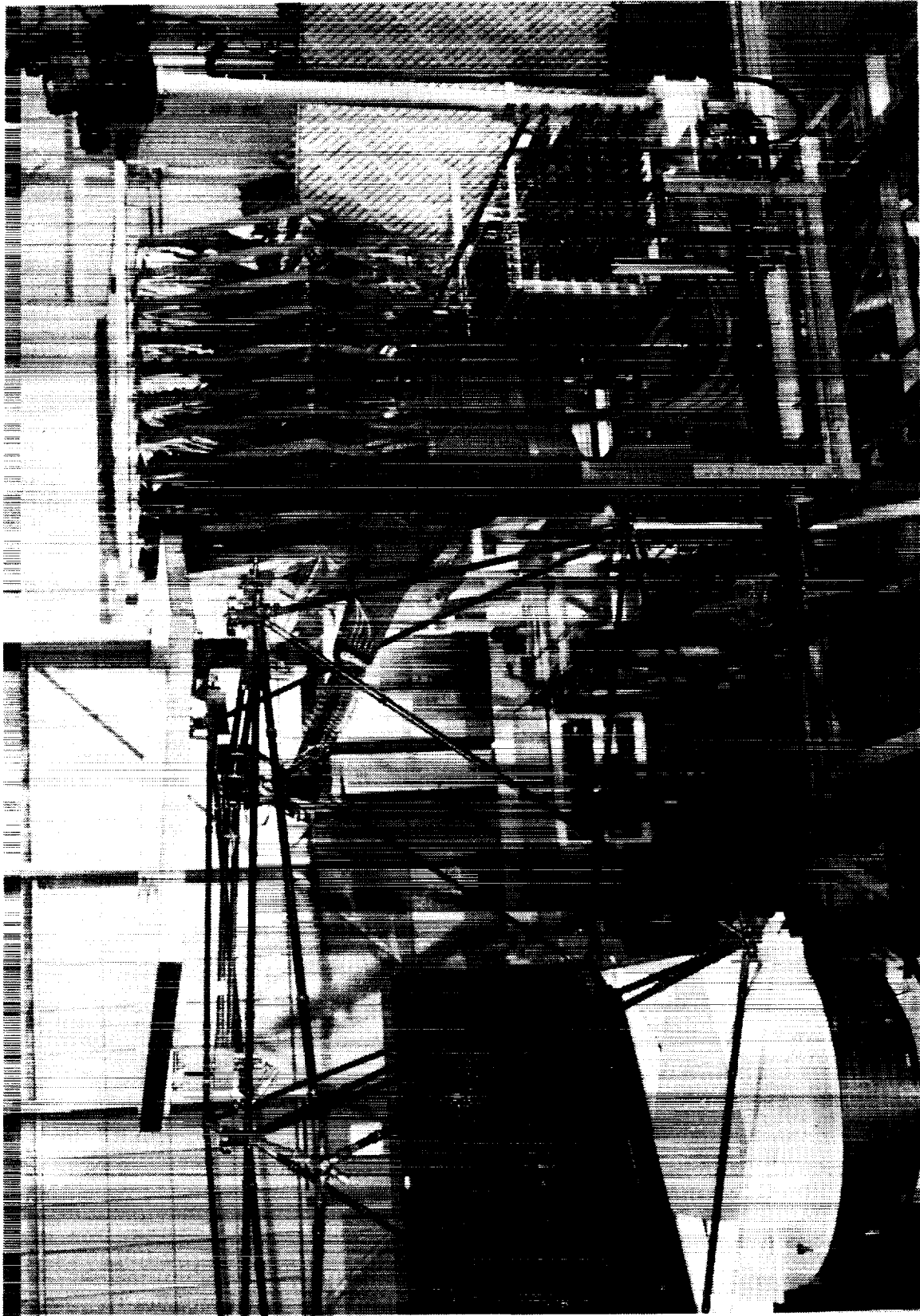

Arm installing panel

ORIGINAL PAGE
BLACK AND WHITE PHOTOGRAPH



Facility view with panel installed



N92-27778

Executive System Software Design
and
Expert System Implementation

Cheryl L. Allen

SOFTWARE REQUIREMENTS

- * Assemble and disassemble a tetrahedral truss in an automated mode
- * Display and control information in support of a supervised autonomy mode of operation
- * Support advanced system integration
- * Accommodate hardware and procedural upgrades

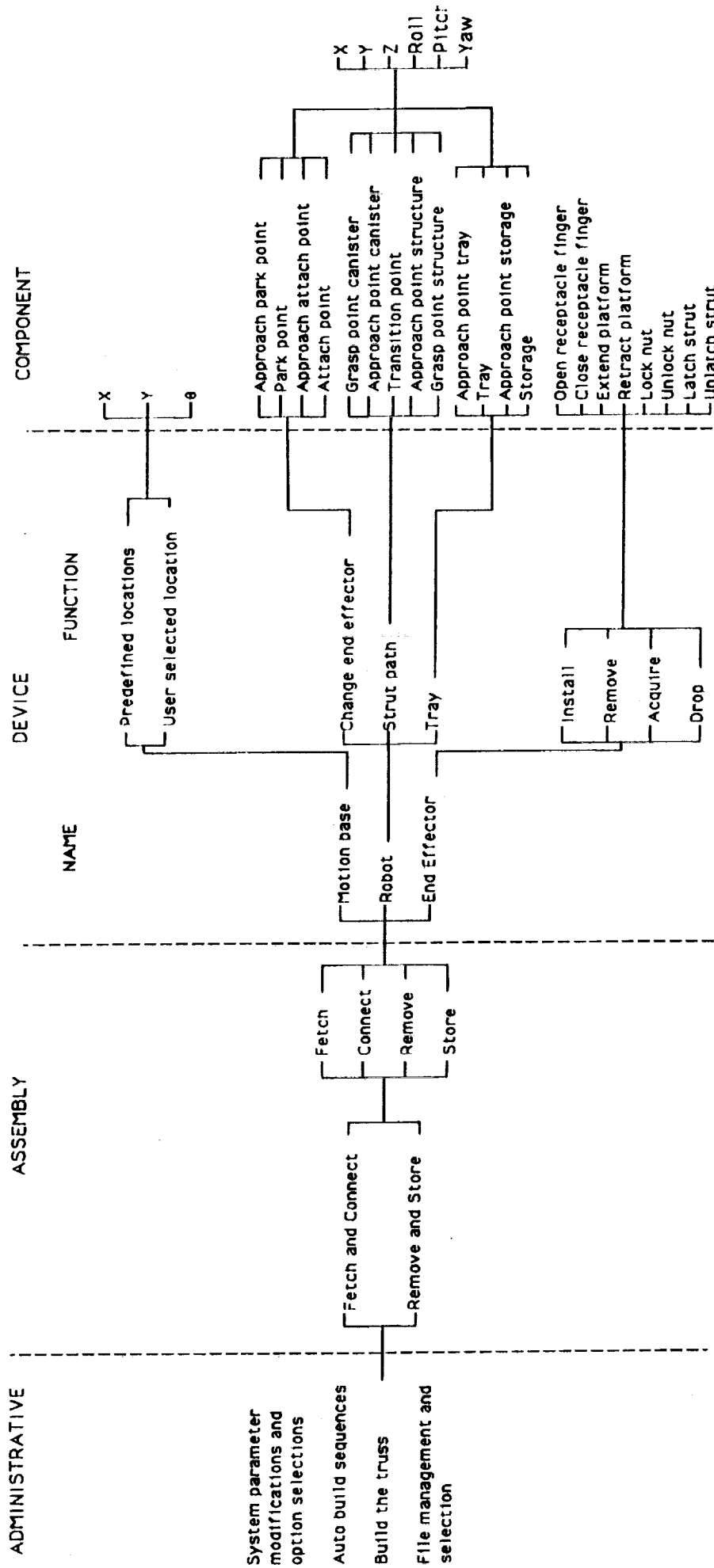

Design layout of the automated assembly system.

EXPERT SYSTEM FEATURES

An expert system is a computer program which uses knowledge and reasoning techniques to solve problems that normally require the services of a human expert.

- * Inference Engine
 - program that applies domain knowledge to known facts to solve problems
 - KES uses a goal-directed method of inferencing

- * Knowledge Base
 - contains known facts that make up the experts knowledge
 - KES contains attributes, classes, rules, and demons

- * Rules
 - infer attribute values
 - KES uses If/Then constructs to represent rules

Legend

Strut installation/removal:

1. Direct
2. Capture sequence
3. Pyramid completion
4. Free

End effector actions:

- a. Capture or release second cantilevered node
- b. Close fingers on end with no node
- c. No nodes on either end of strut, close remaining end
- d. Capture or release end of strut
- e. No strut in hand

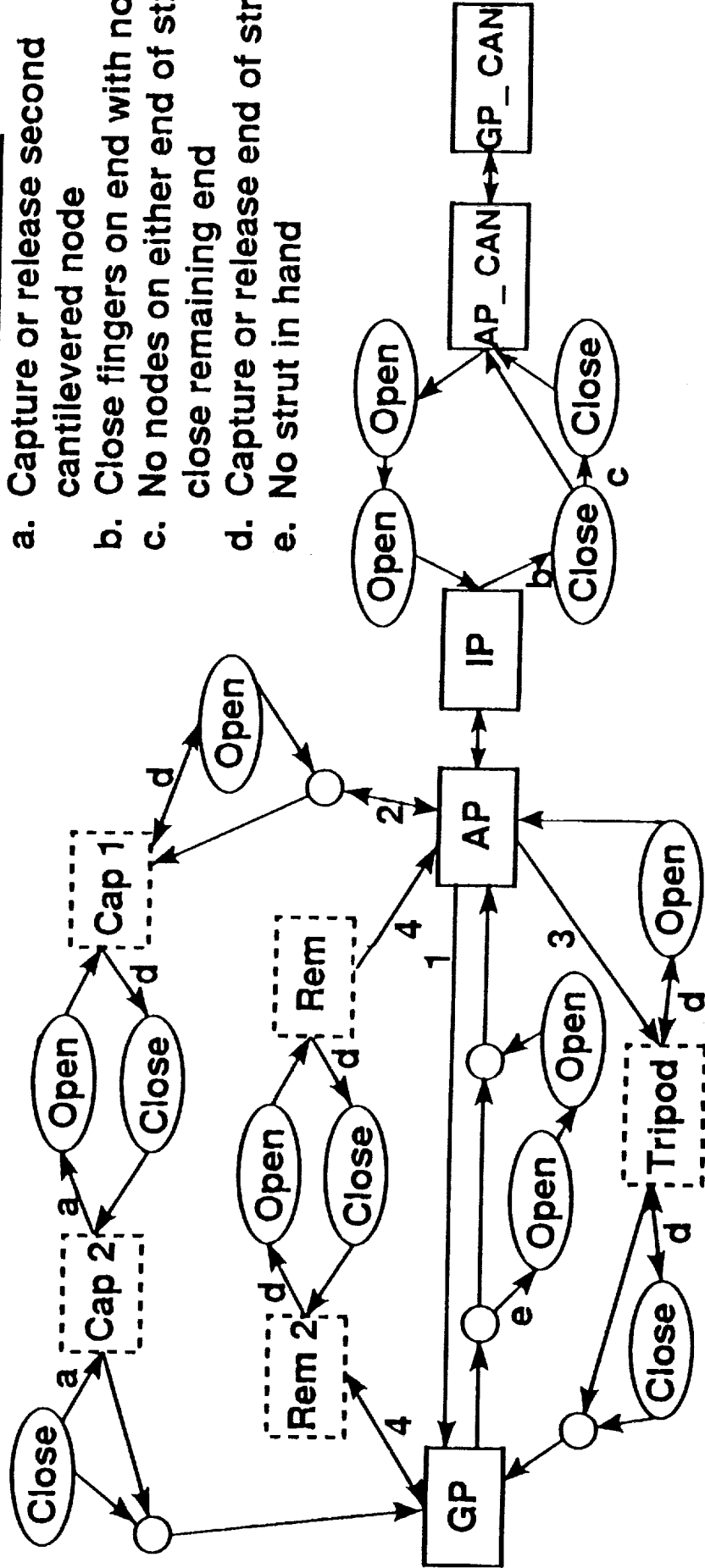

Complete robot arm state diagram and logic.

EXPERT SYSTEM BENEFITS

- * Concise encapsulation of logic into rules
 - directs sequence of moves necessary to assemble and disassemble a strut, determine tray operations, control panel installation/removal, command motion base and end effector at the device level

- * Embedded within existing Fortran executive
 - uses KES for decision making while leaving familiar operator interface intact

- * Reduced amount of code for maintenance
 - 20 if/then rules replaced approximately 850 lines of Fortran code

- * Eased system upgrades
 - implemented panel functions in just over 1 month

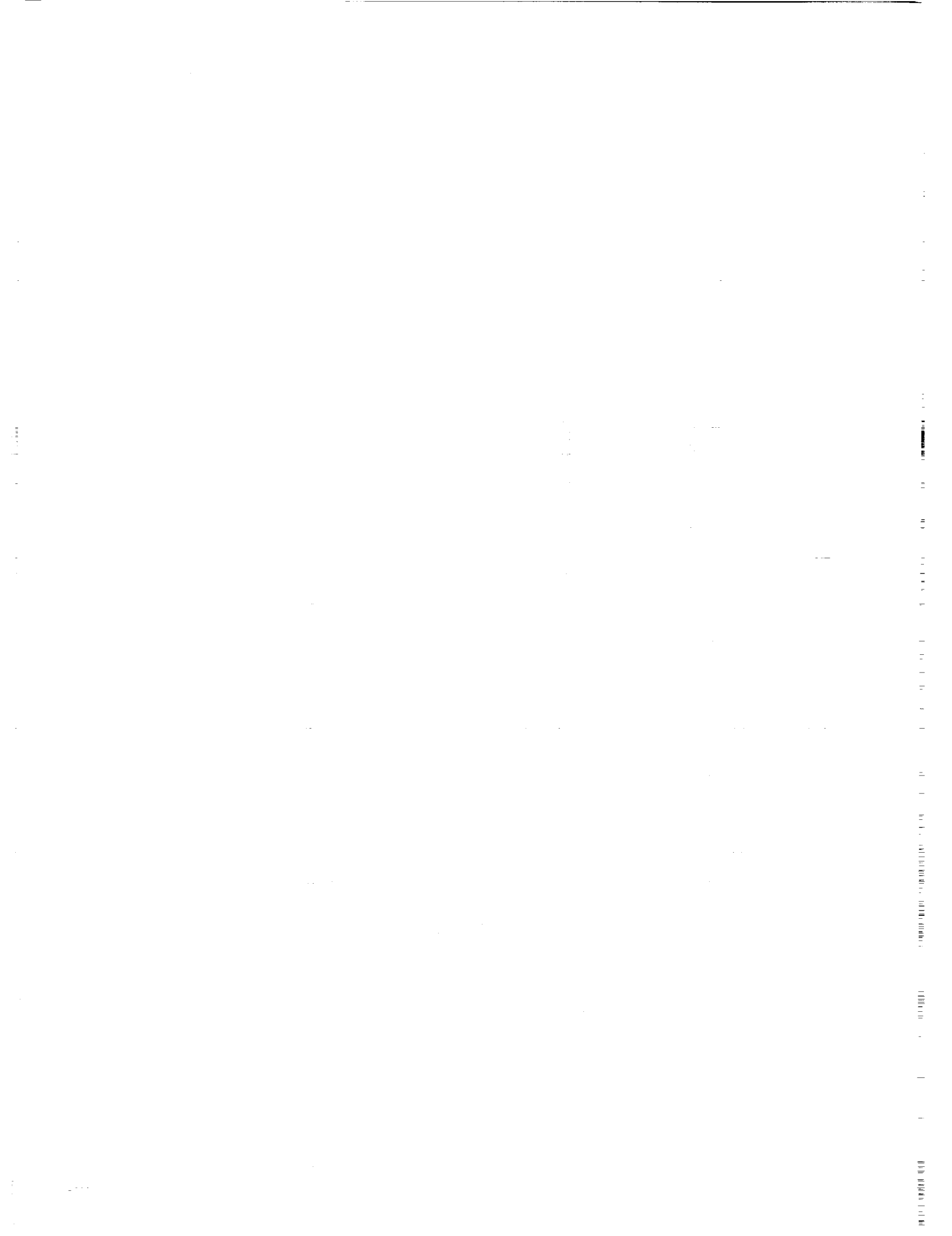

**FUTURE WORK IN
AUTOMATED ASSEMBLY OF
LARGE SPACE STRUCTURES**

Ralph Will

Automated Assembly of Large Space Structures

Project Development

"Dumb" assembly of planar truss using taught points & dedicated robot positions



Expanded truss assembly with payloads, panels, sensor guidance and graphics simulation



Curved truss structure, system dynamics and coordinated motion



"Smart" assembly of complex integrated system with sensor guidance and collision avoidance path planner

Current System Upgrade Requirements

* Taught Paths and Points Are Not Viable

- Sensor/Vision Feedback
- Path Planner/Collision Avoidance

* Flat Truss Is Not Useful

- Curved Truss/Generalized End Effector

* Serial System with Excessive Communication

- Distributed Architecture & Embedded Microprocessors

* Single-Task Operation

- Panel Installation
- Beam Assembly

* Need Flexibility of Knowledge-Based Artificial Intelligence

- Expert System Executive
- Automated Path Planning
- Automated Sequence Planning

ASAL 1992 OBJECTIVES

- I. Complete end-to-end assembly/disassembly of combination Truss/Panel structure using:
 - Machine vision for struts
 - Expert system executive
 - End effector microprocessors

- II. Static manipulator arm will develop:
 - Generalized end effector sequences & procedures for curved truss, supported by expert system
 - VX-Works based distributed architecture for in-loop force/torque & path planning

- III. Real-time graphics simulation to:
 - Develop generalized end effector paths
 - Study assembly sequence planning
 - study operator interfaces

- IV. Design end effector for curved Precision Segmented Reflector (PSR) truss joints which are not specifically designed for robotic operations

- V. Assemble tetrahedral beam

On the Use of Torque-Wheels For the Control of Large, Flexible, Space-based Telerobotic Arms

D. Ghosh, R. C. Montgomery and S. P. Kenny
NASA Langley Research Center
Hampton, VA 23665

1991 NASA Langley Workshop on Automation and Robotics
for Space-based Systems

December 10, 1991
Hampton, Va

N92-27780

Presentation Outline

- PROBLEM
- POTENTIAL SOLUTION -- END-POINT CONTROL
- MODELLING, ANALYSIS, AND CONTROL SYSTEM
- EVALUATION TASK
- SYSTEM SIMULATOR
- STUDIES WITH-AND-WITHOUT TORQUE-WHEELS
- CONCLUSIONS AND FUTURE PLANS

THE PROBLEM

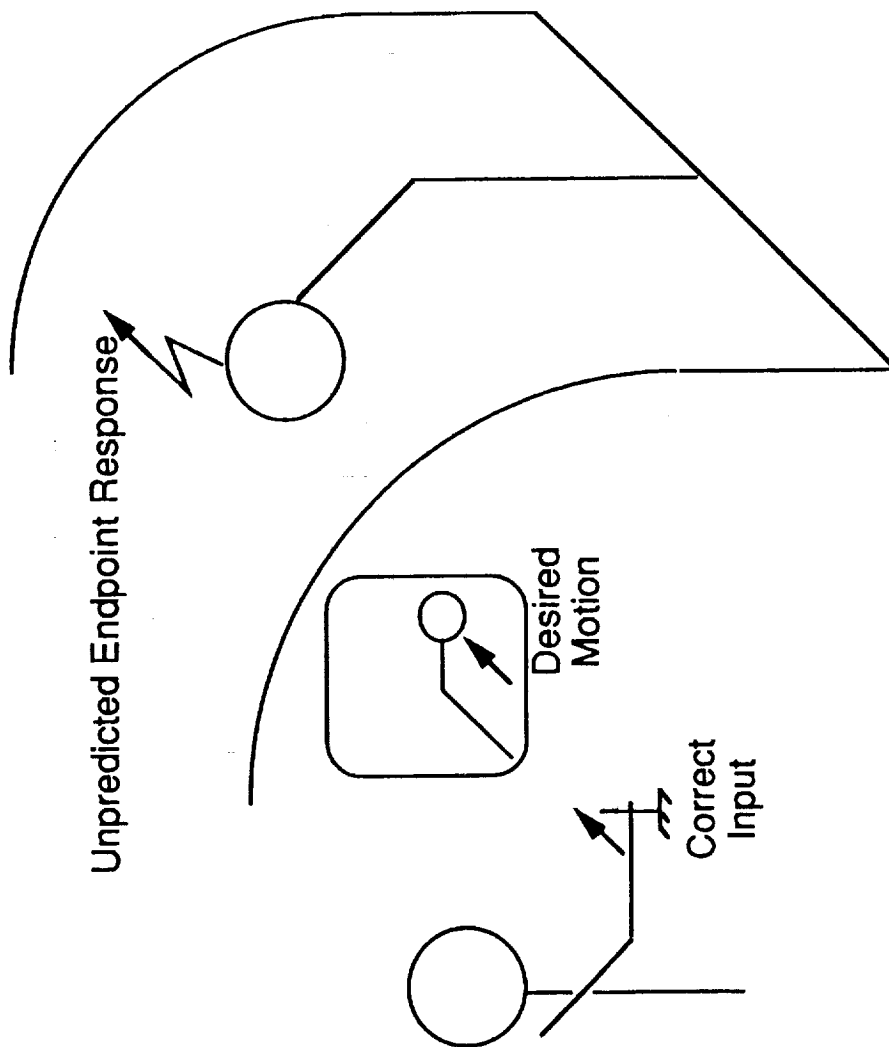

Potential Solution

- End-Point Control with Inertial Components -

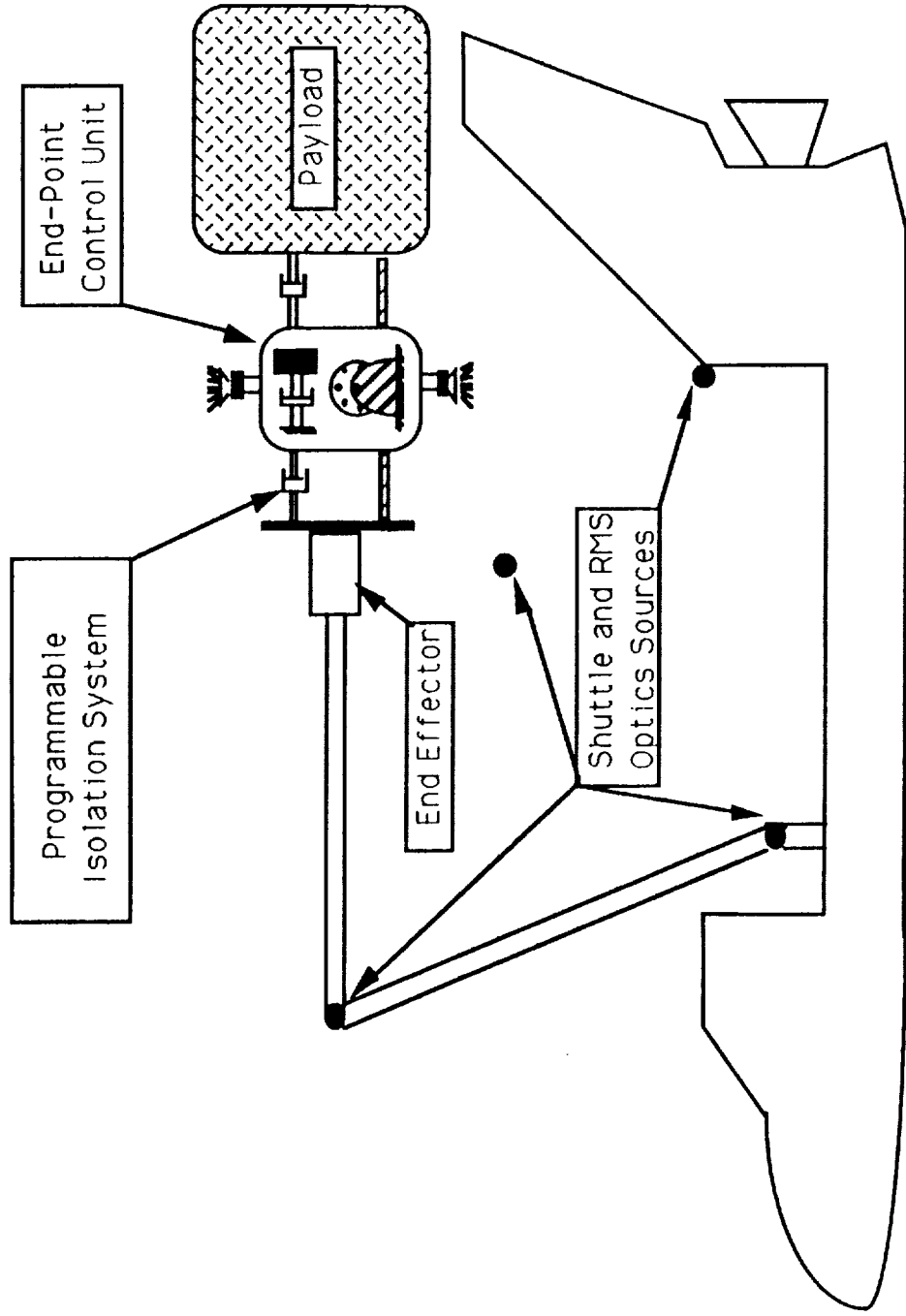

System Model Used

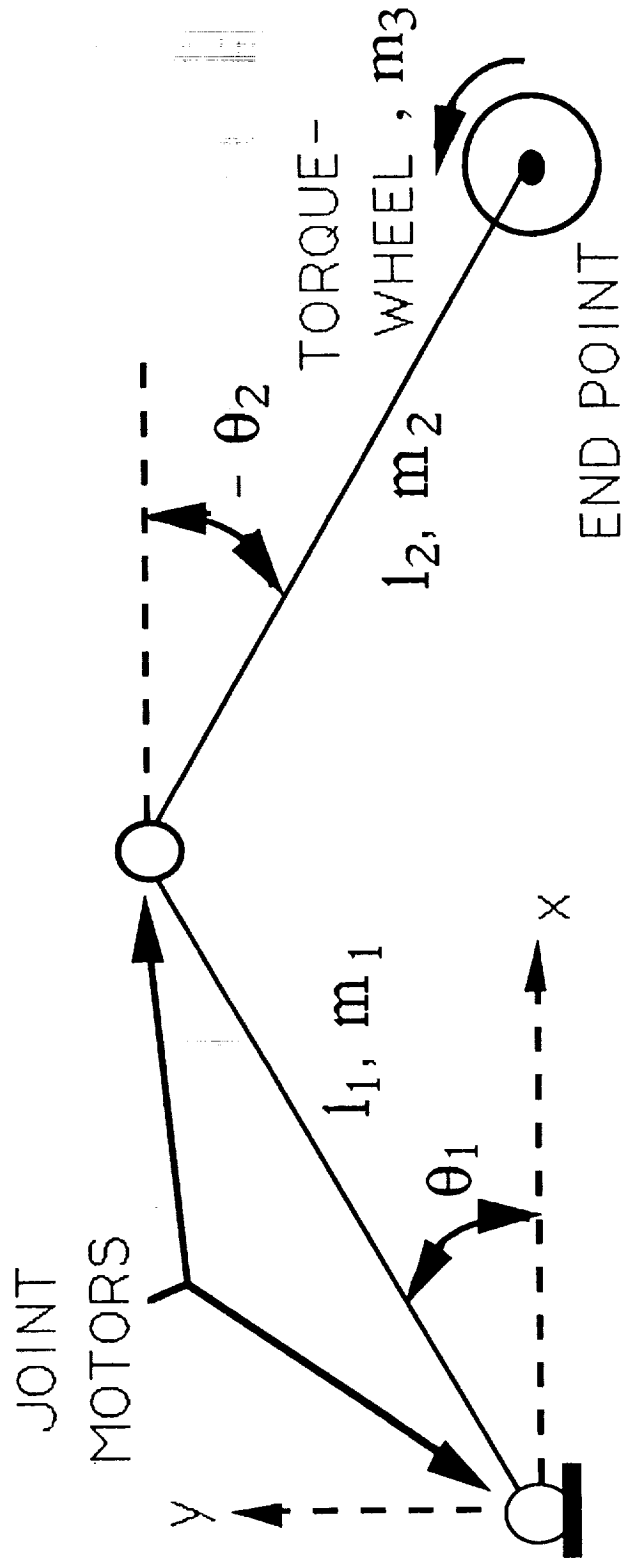

Joint Motor Modelling

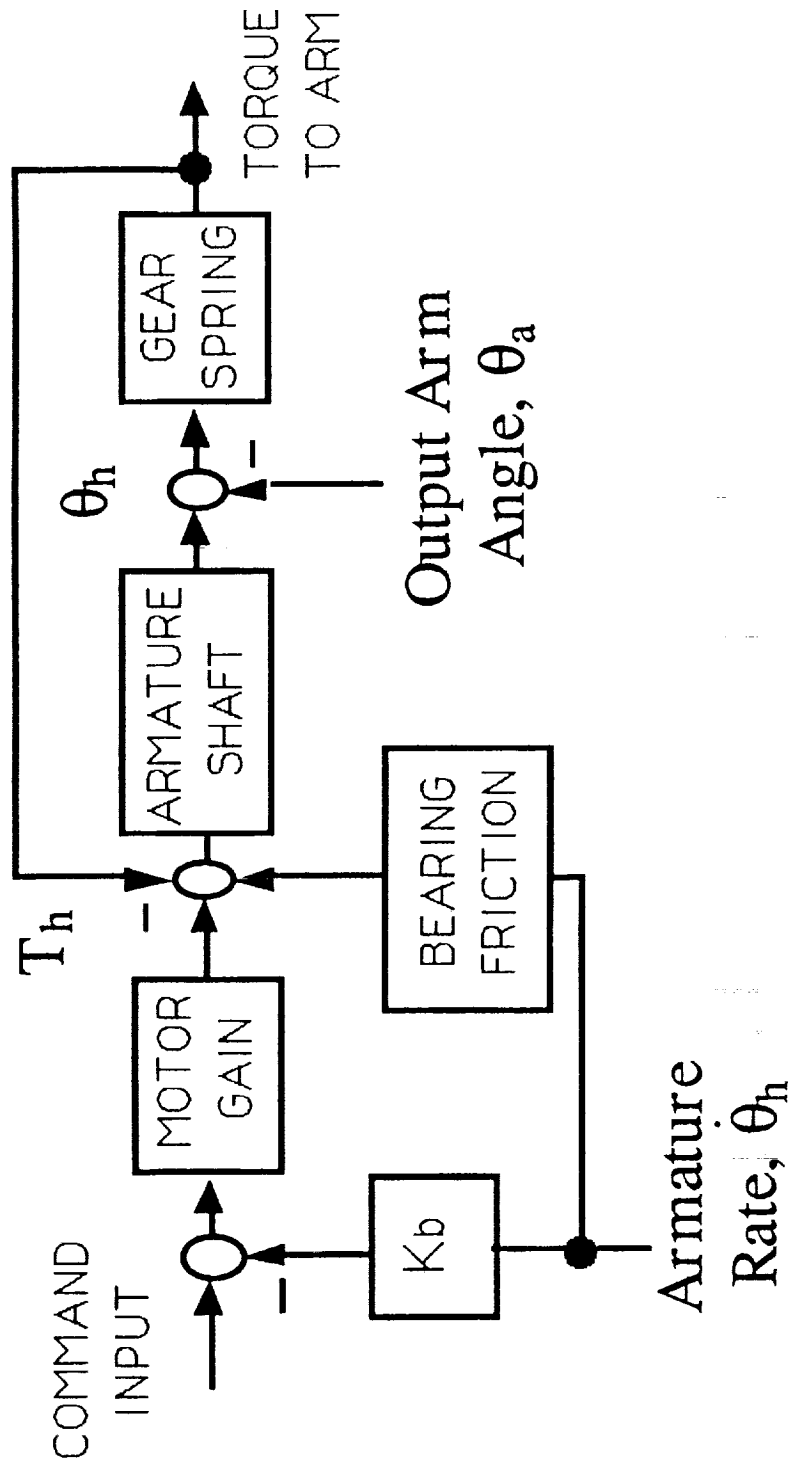

Analysis Equations

Energy Method Used

Equations of Motion

$$\frac{d}{dt} \left(\frac{\partial L}{\partial \dot{q}_i} \right) - \frac{\partial L}{\partial q_i} = \frac{\partial W}{\partial q_i} - \frac{\partial F}{\partial \dot{q}_i}$$

Lagrangian $L = T - V$

Raleigh Dissipation F

Virtual Work W

Analysis Equations

Energy Method Used

(Continued)

Shoulder Joint Motor

$$I_{s1} \ddot{\theta}_{s1} = k_{x1} (\theta_1 - \theta_{s1}) + k_{v1} (\dot{\theta}_1 - \dot{\theta}_{s1}) + T_{E1}$$

Shoulder Link

$$\begin{aligned} & \left(\frac{m_1}{3} + m_2 + m_3 \right) l_1^2 \ddot{\theta}_1 \\ & + \left(\frac{m_2}{2} + m_3 \right) l_1 l_2 \ddot{\theta}_2 \cos(\theta_1 - \theta_2) \\ & + \left(\frac{m_2}{2} + m_3 \right) l_1 l_2 \dot{\theta}_2^2 \sin(\theta_1 - \theta_2) \\ & + k_{x1} (\theta_1 - \theta_{s1}) = -k_{v1} (\dot{\theta}_1 - \dot{\theta}_{s1}) - T_{E2} \end{aligned}$$

Analysis Equations

Energy Method Used (Continued)

Elbow Joint Motor

$$I_{s2} \ddot{\theta}_{s2} = k_{x2} (\theta_1 - \theta_{s1}) + k_{v2} (\dot{\theta}_1 - \dot{\theta}_{s1}) + T_{E2}$$

Forearm Link

$$\begin{aligned} & \left(\frac{m_2}{3} + m_3 \right) l_2^2 \ddot{\theta}_2 + \left(\frac{m_2}{2} + m_3 \right) l_1 l_2 [\ddot{\theta}_1 \cos(\theta_1 - \theta_2) \\ & \quad - \dot{\theta}_1^2 \sin(\theta_1 - \theta_2)] + k_{x2} (\theta_2 - \theta_{s2}) = \\ & \quad = -k_{v2} (\dot{\theta}_2 - \dot{\theta}_{s2}) + T_{TW} \end{aligned}$$

Control System

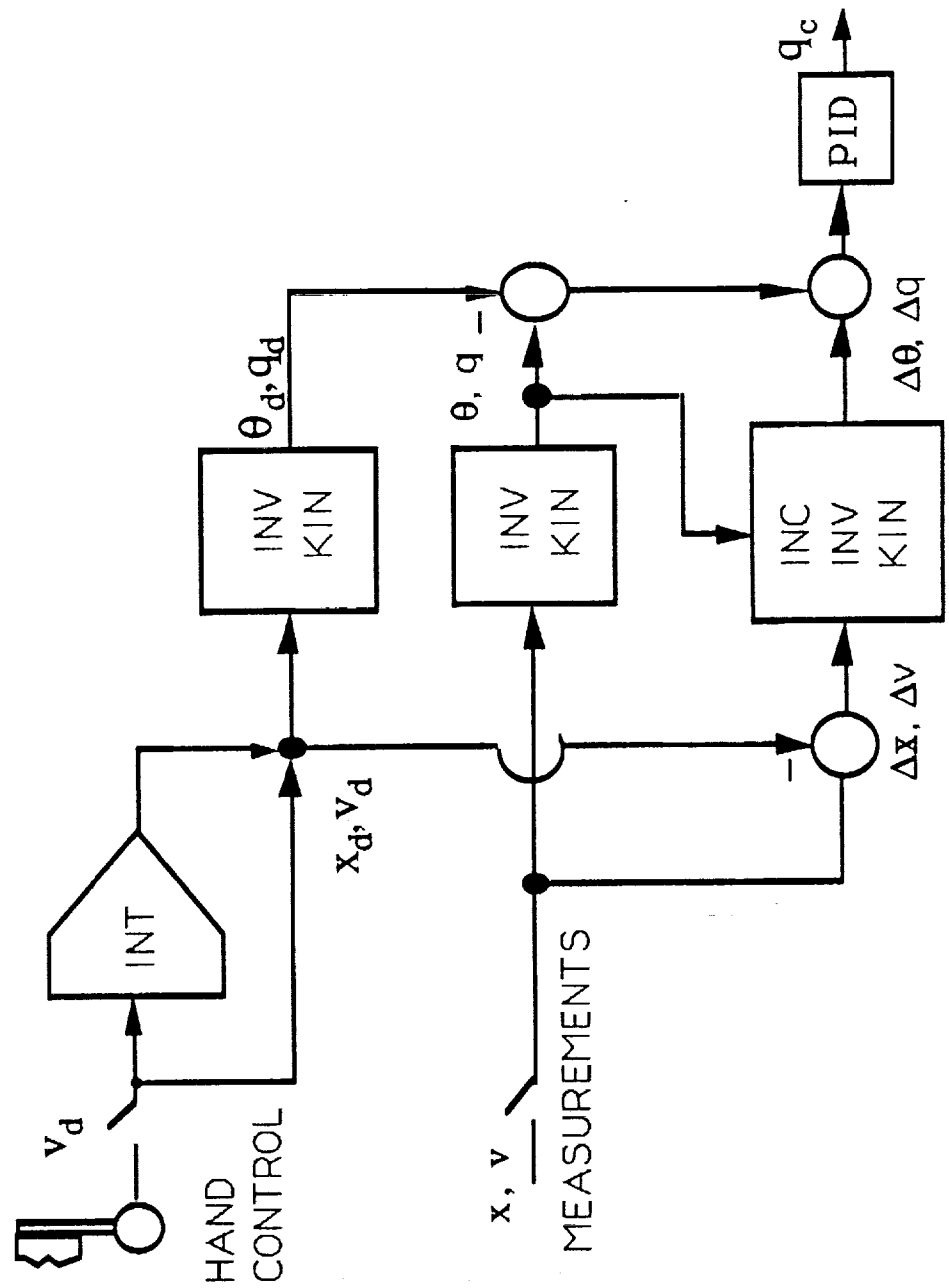

Evaluation Task

Arrest the Motion of the Arm

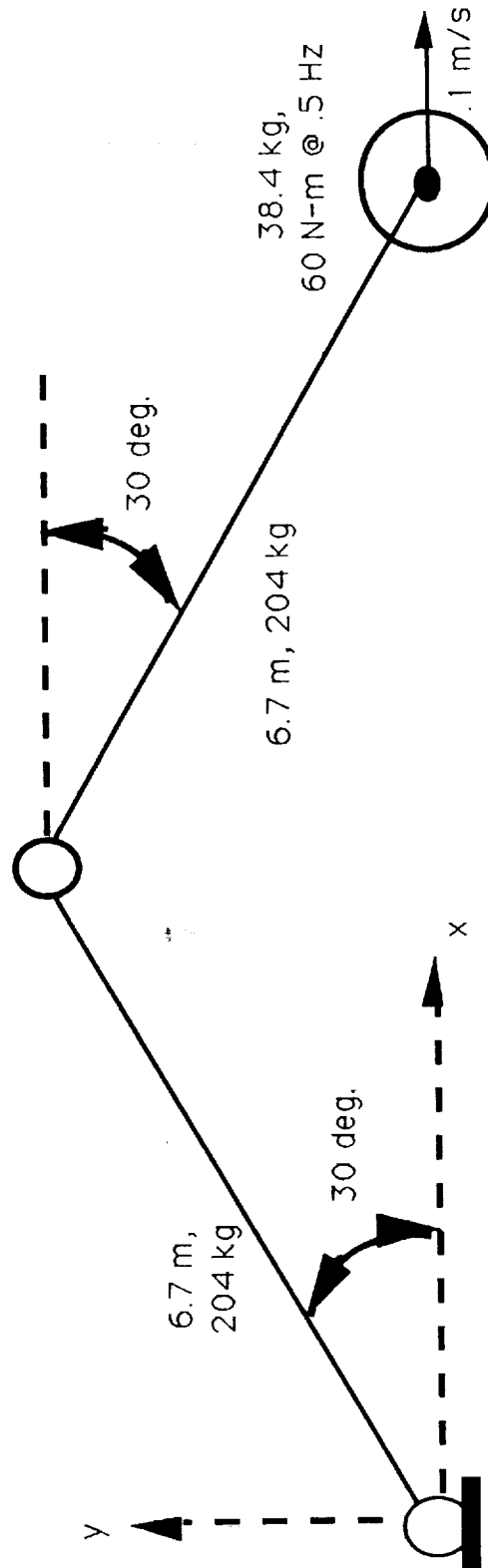

System Simulator

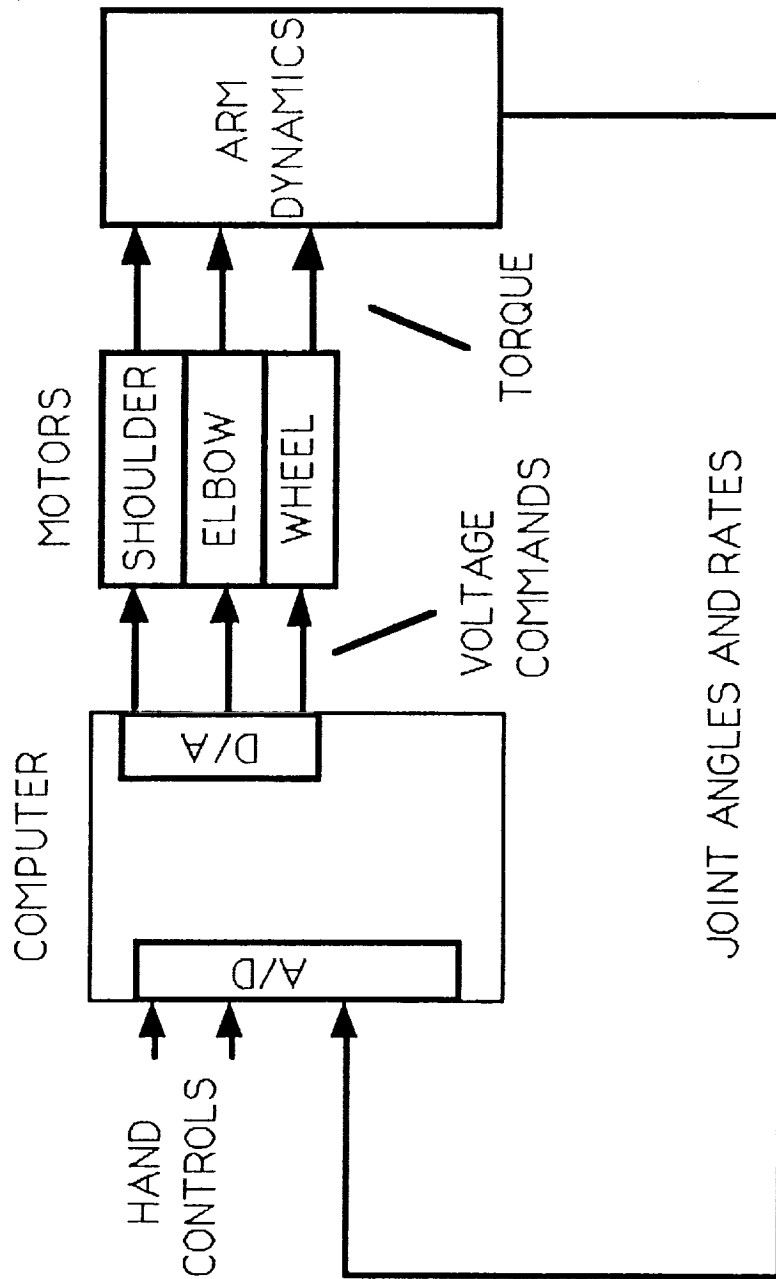

Torque-Wheel Commands

Arresting Task

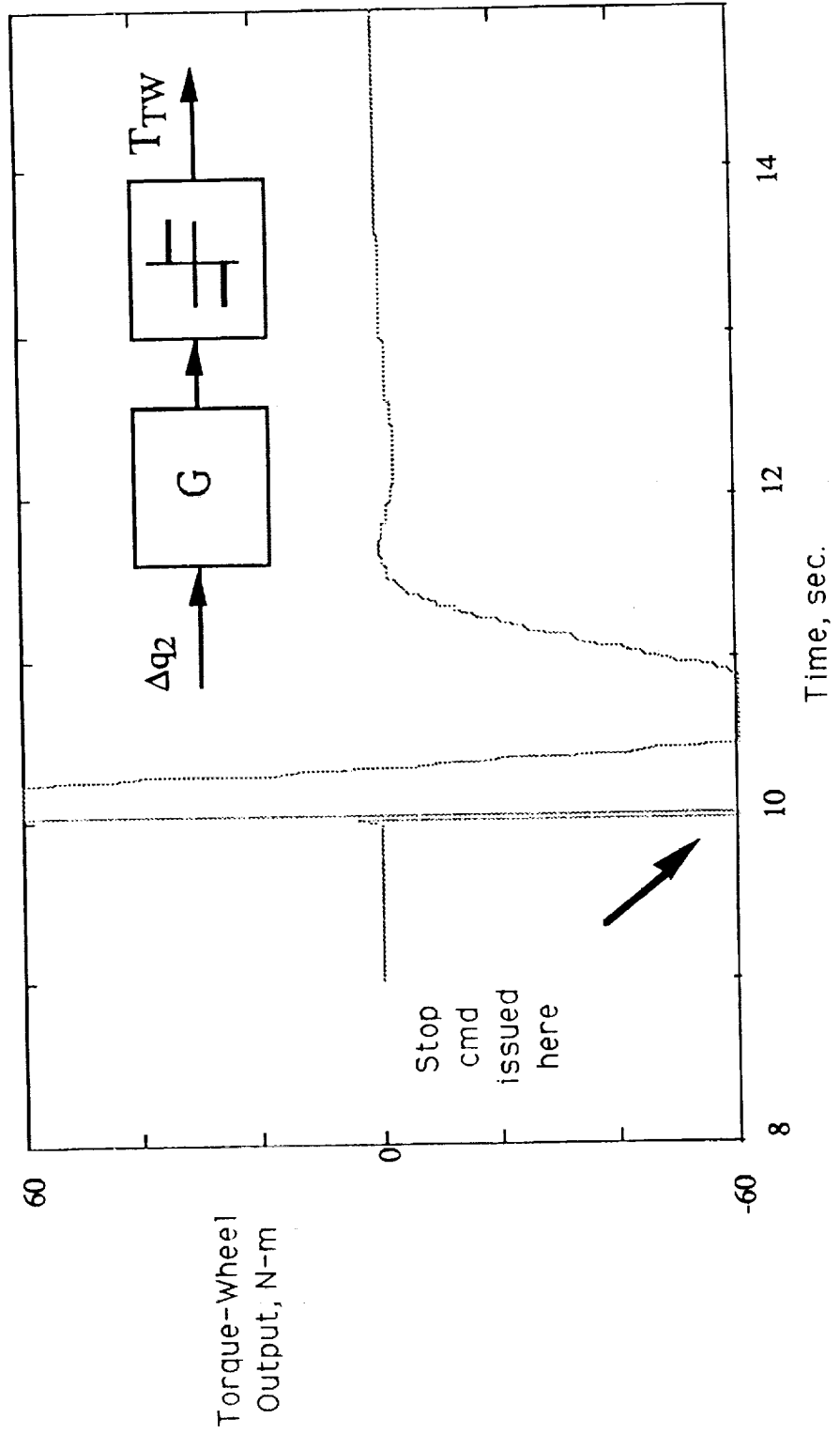

Performance With and Without Torque-Wheels End-Point Motion for Arresting Task

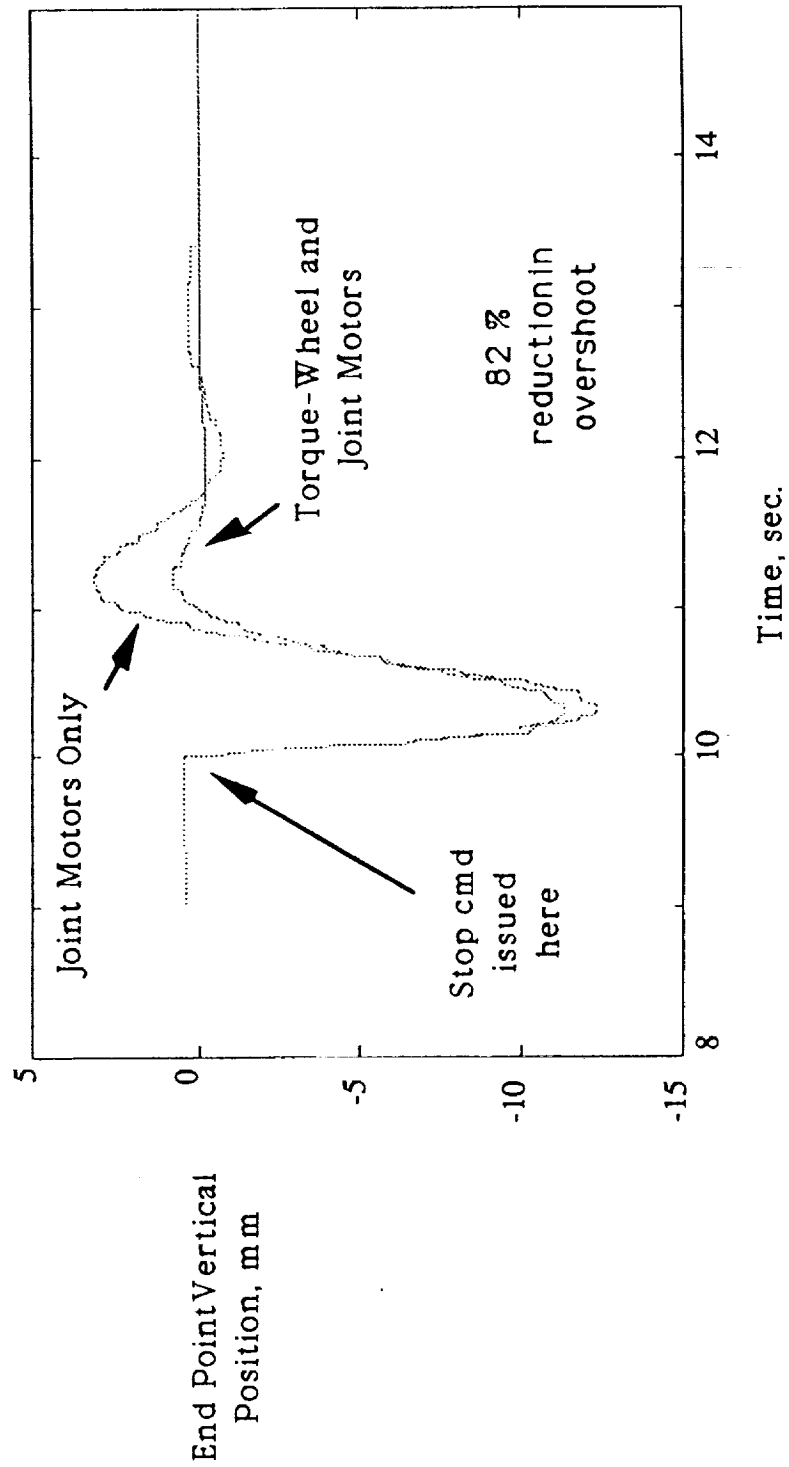

Experimental Facility Planned

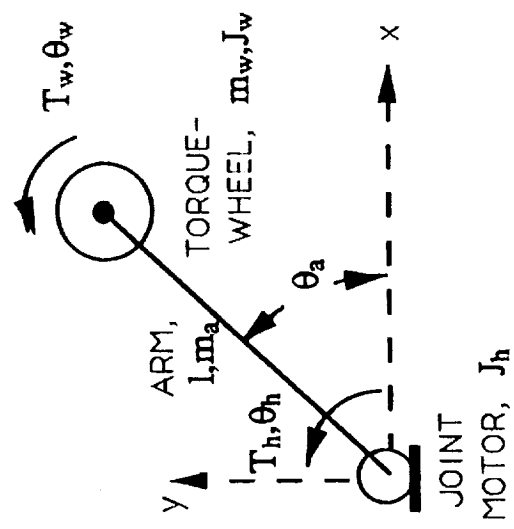
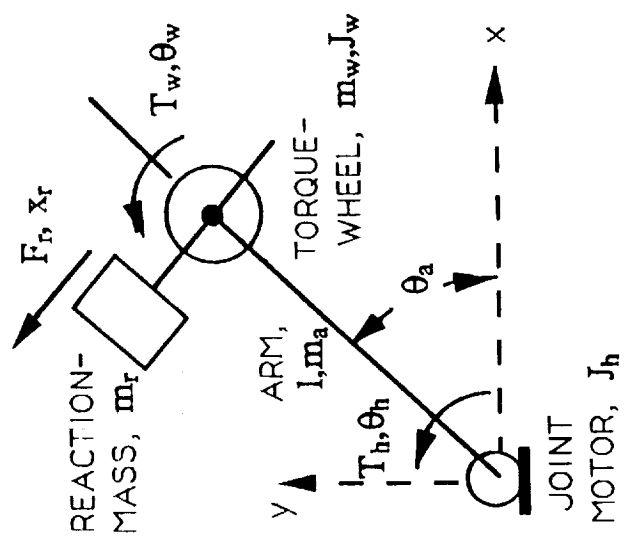

Conclusions and Future Plans

Conclusion -- Torque-wheels can be of value in suppressing vibrations -- 82% reduction in overshoot for abrupt stop commands.

- Future simulator evaluations:
 - include reaction mass actuators
 - manual control
 - detailed models of flexibility
- Hardware evaluations

Modeling, Control, and Simulation of Flexible Link Robotic Systems

Sean P. Kenny

Spacecraft Controls Branch
NASA Langley Research Center

December 10, 1991

N92-27781

WBS PROGRAM GOAL ROADMAP WBS 40 - 1 Advanced System Modeling and Control

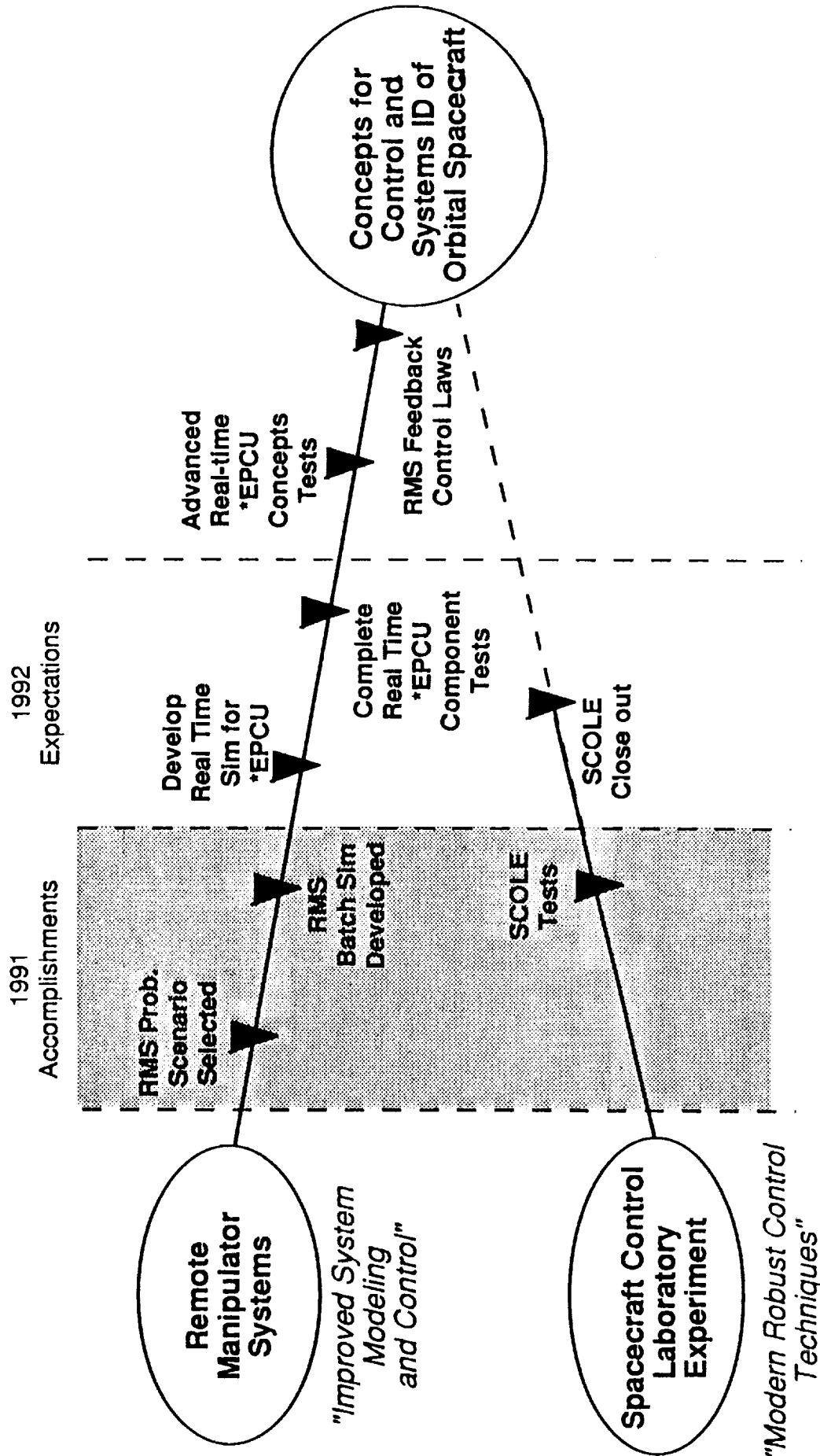

* EPCU End Point Control Unit

INTEGRATED SOFTWARE ENVIRONMENT

MODELING	CONTROL	SIMULATION
MAPLE <i>(Symbolic Mathematics)</i>	MATLAB <i>(Control Design)</i>	GRAPHICS WORKSTATION
<ul style="list-style-type: none"> • Automated Model Development. • Symbolic Matrix Inversion for Nonlinear Models. • Automated "C" Code generator. 	<ul style="list-style-type: none"> • Utilize Callable "C" Subroutines Generated in MAPLE. • Classical State Space • Robust Digital 	<ul style="list-style-type: none"> • Real Time Graphics. • Interactive. (man-in-the-loop control) • Interface to MATLAB and MAPLE. • "X Windows" Portability.

MODELING SOFTWARE: MAPLE (*SYMBOLIC MATHEMATICS*)

- **OBJECTIVE:**
 - Develop a software environment to automate the process of implementing Hamilton's or Lagrange's equations of motion.
- **ADVANTAGES:**
 - Fewer errors.
 - Reduce the number of floating point operations in simulations by simplifying complex expressions, e.g. symbolic matrix inversion, and matrix-vector multiplication.
 - Provide a practical way to generate reliable equations.
- **DISADVANTAGES:**
 - Extremely memory intensive.
 - Difficulties handling multiple complex mode shape expressions.

MODELING SOFTWARE: MAPLE

M.I.T. developed applications package

- CAPABILITIES:
 - > Planar motion of a flexible manipulator (base fixed relative to inertia space.)
 - > Up to 9 links.
 - > Inertial or relative coordinates
 - > Individual links can be rigid or flexible, but:
 - I. A Bernoulli-Euler is assumed (no shear.)
 - II. An assumed modes method (user specifies mode shapes.)
 - > Stiffening effects due to rotation can be included.
 - > Joints can have masses (including tip mass), and flexibility but no inertias.

MODELING SOFTWARE: M.I.T. sample input data file

COORDS:= inertial	# Coordinate system used
FORESHORTEN:= no;	# Foreshortening effect
ORTHOG:= yes;	# Orthogonal mode shapes
NL:= 1;	# Number of links
n1:= 2;	# Number of modes per link
qstar1:= [TH1,Q11,Q12];	# List of generalized coords.
m01:= 0;	# Root mass
mL1:= m0;	# Tip mass
k1:= infinity;	# Joint stiffness
EI1:= EI;	# Beam stiffness
rhoA1:= rhoA;	# Beam mass per unit length
phi11:= < sin(Pi*x/L) x >;	# Mode shape 1
phi12:= < sin(2*Pi*x/L) x >;	# Mode shape 2

CONTROL DESIGN INTERFACE

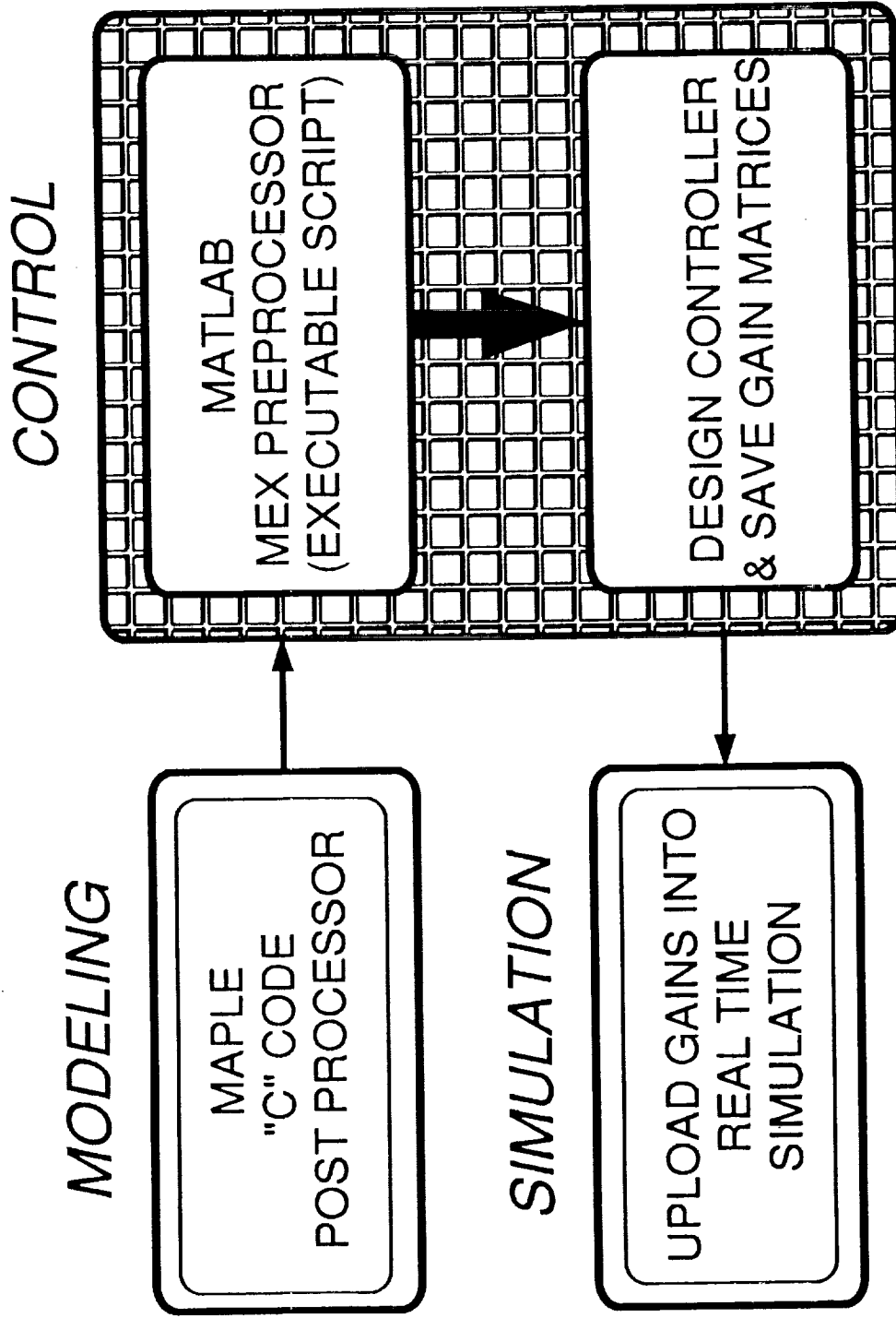

REAL TIME SIMULATION

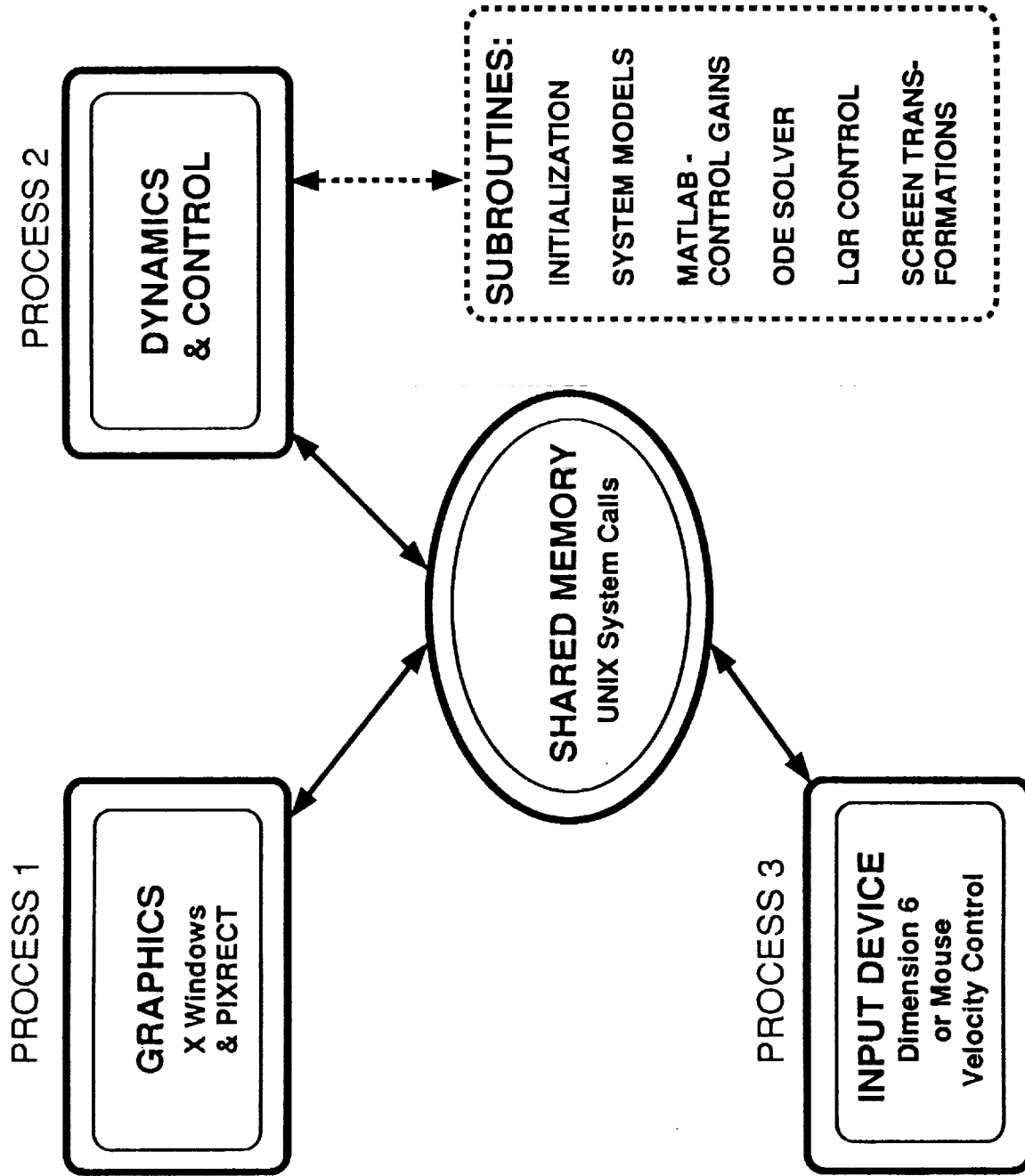

GRAPHICS WORKSTATION

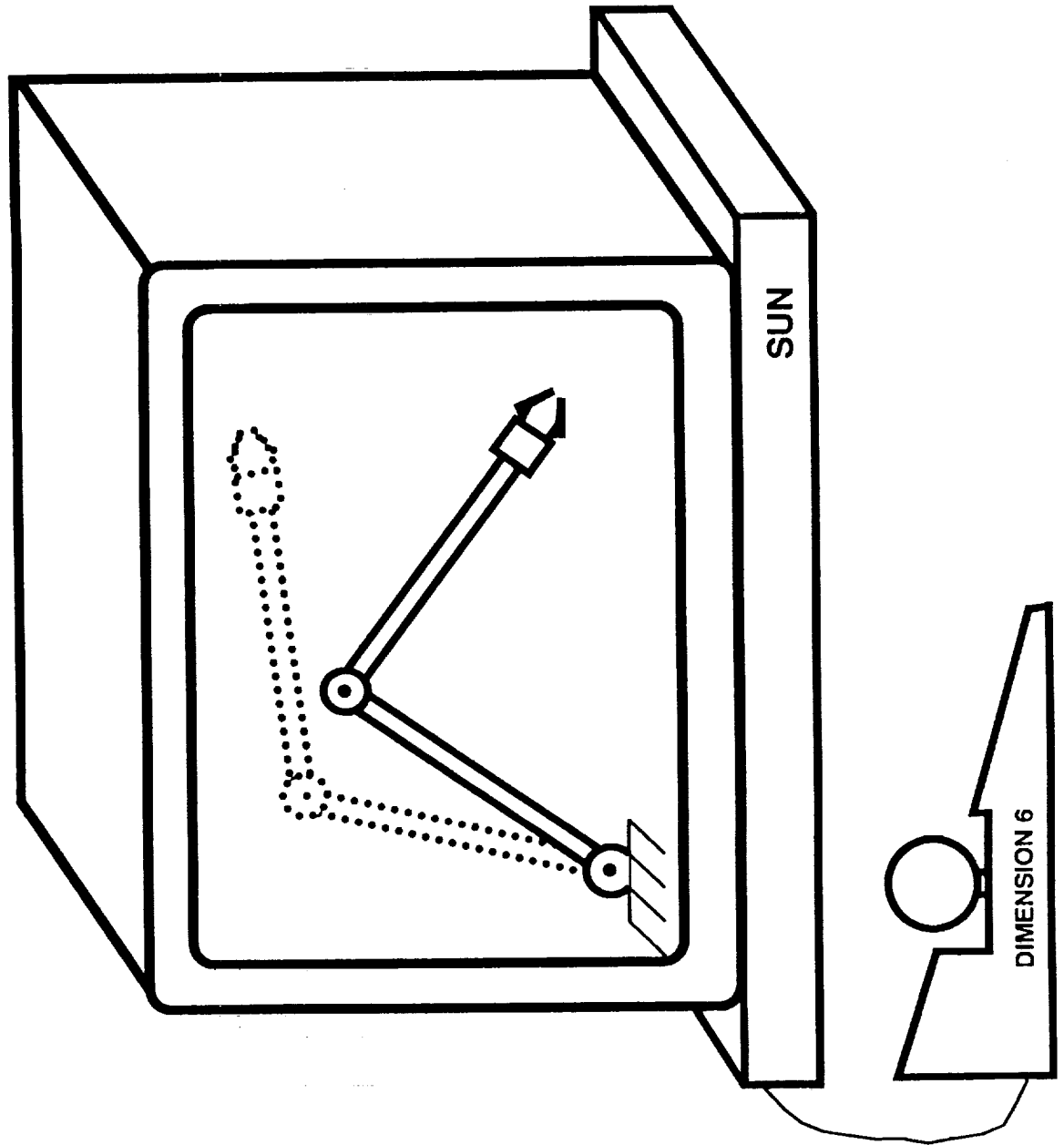

CLOSING REMARKS

- While not a panacea for all robotics modeling problems, symbolic mathematics programs represent a valuable tool for generating equations of motion for flexible link robotic systems.
- Desk top workstation simulators provide an economical environment to evaluate man-in-the-loop control, as well as the active damping characteristics of robotic systems.

**PASSIVE DYNAMIC CONTROLLERS FOR
NON-LINEAR MECHANICAL SYSTEMS**

**Jer-Nan Juang, Shih-Chin Wu,
Minh Phan, and Richard W. Longman**

**NASA Langley Research Center
Hampton, VA 23665**

N92-27782

OUTLINE

- MOTIVATION
- OBJECTIVE
- APPROACH
- BASIC CONCEPTS
- PHYSICAL INTERPRETATION
- APPLICATION
- CONCLUSIONS

MOTIVATION

- **FEATURES OF A DEVELOPED VIRTUAL PASSIVE CONTROLLER FOR VIBRATION CONTROL OF LINEAR SYSTEMS**
 - energy dissipative
 - robust in stability to system uncertainties
 - interpreted physically
- **PROPOSED MODEL-INDEPENDENT SECOND-ORDER DYNAMIC CONTROLLER IS EXTENDED TO NON-LINEAR MULTI-BODY MECHANICAL SYSTEMS**

OBJECTIVE

- DEVELOP ACTIVE MODEL-INDEPENDENT CONTROLLERS FOR SLEWING AND VIBRATION CONTROL OF NON-LINEAR MULTI-BODY FLEXIBLE SYSTEMS, INCLUDING FLEXIBLE ROBOTS

PASSIVE STABILIZATION

PASSIVE STABILIZING ELEMENTS

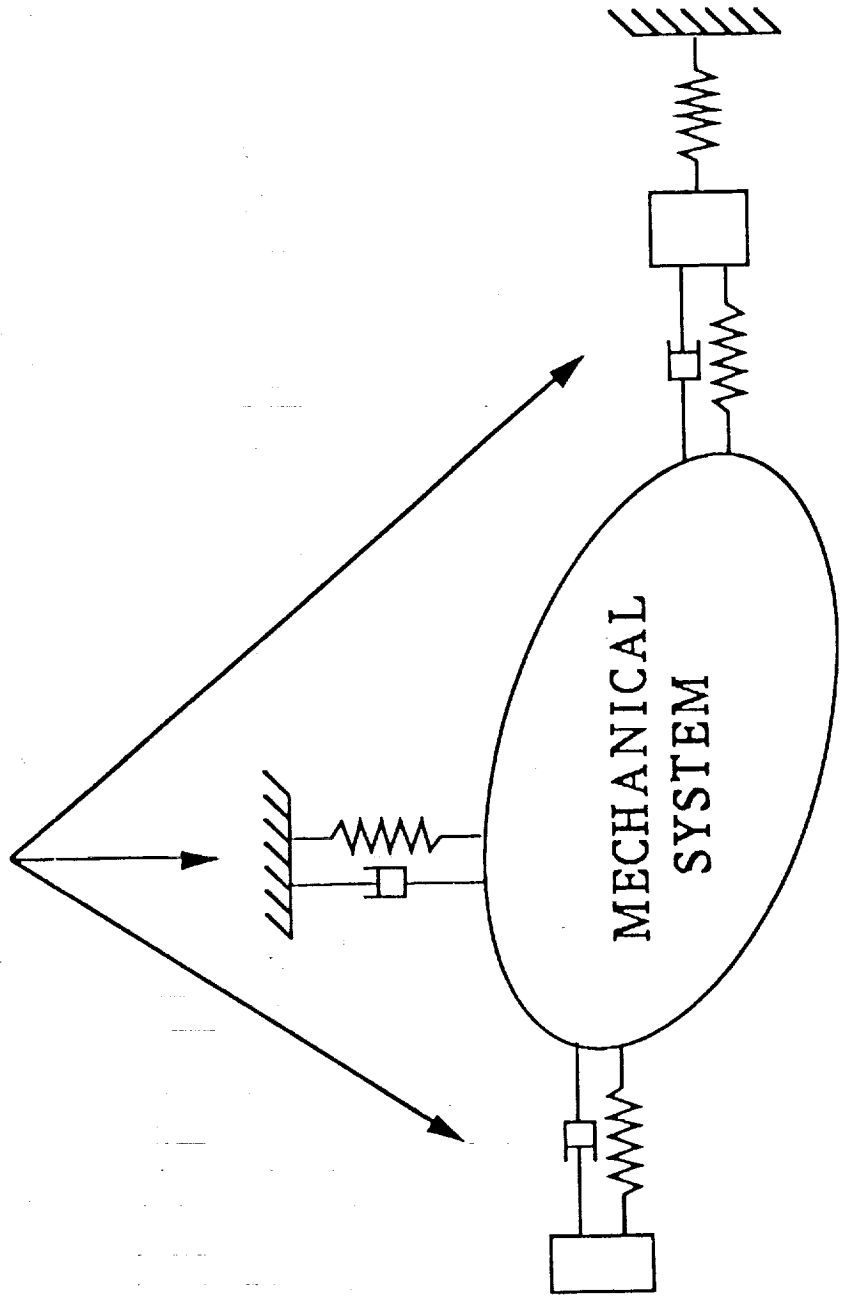

APPROACH

- **THEORY FOR LINEAR SYSTEMS**
 - second-order differential equations
 - energy dissipative
 - robust in stability to system uncertainties
 - interpreted physically
- **EXTENSION TO NON-LINEAR SYSTEMS IS BASED ON**
 - Work-Energy Rate principle
 - Liapunov stability theory

BASIC CONCEPT (Work-Energy)

- WORK-ENERGY RATE PRINCIPLE
- For holonomic and scleronomic mechanical systems

$$\frac{dT}{dt} = u^T \dot{x}_a$$

where

T = Total kinetic energy

u = Generalized control force

x_a = Vector of generalized coordinates

where control force is applied

BASIC CONCEPT (Liapunov Theory)

● STANDARD LIAPUNOV STABILITY THEORY

- Positive definite Liapunov function

$$L = L(x_a, \dot{x}_a, \bar{x}, \dot{\bar{x}})$$

where \bar{x} = Vector of remaining generalized coordinates

- System is asymptotically stable if

$$\frac{dL}{dt} < 0$$

LIAPUNOV FUNCTION (Displacement Feedback)

- POSITIVE SEMI-DEFINITE LIAPUNOV FUNCTION

$$L = T + \frac{1}{2} \dot{x}_c^T M_c \dot{x}_c + \frac{1}{2} (x_a - x_c)^T K_{c1} (x_a - x_c) + \frac{1}{2} x_c^T K_{c2} x_c$$

where x_c = controller coordinates

- NEGATIVE SEMI-DEFINITE TIME DERIVATIVE OF LIAPUNOV FUNCTION

$$\frac{dL}{dt} = -\dot{x}_c^T D_c \dot{x}_c \leq 0$$

- Asymptotic stability can be accomplished even though the Liapunov function is only positive semi-definite and its time derivative is only negative semi-definite.

DYNAMIC CONTROLLER (Displacement Feedback)

● SYSTEM

$$M\ddot{x} + f(x, \dot{x}) = Bu ; \quad x = \begin{bmatrix} x_a \\ \bar{x} \end{bmatrix}$$

● DYNAMIC CONTROLLER

$$M_c \ddot{x}_c + D_c \dot{x}_c + (K_{c1} + K_{c2}) x_c = K_{c1} x_a$$

$$u = -K_{c1} (x_a - x_c)$$

LIAPUNOV FUNCTION (Displacement & Acceleration Feedback)

- POSITIVE SEMI-DEFINITE LIAPUNOV FUNCTION

$$L = T + \frac{1}{2}(\dot{x}_a + \dot{x}_c)^T M_c(\dot{x}_a + \dot{x}_c) + \frac{1}{2}x_c^T K_{c1}x_c + \frac{1}{2}(x_a + x_c)^T K_{c2}(x_a + x_c)$$

where x_c = controller coordinates

- NEGATIVE SEMI-DEFINITE TIME DERIVATIVE OF LIAPUNOV FUNCTION

$$\frac{dL}{dt} = -\dot{x}_c^T D_c \dot{x}_c \leq 0$$

- Asymptotic stability can be accomplished even though the Liapunov function is only positive semi-definite and its time derivative is only negative semi-definite.

DYNAMIC CONTROLLER (Displacement & Acceleration Feedback)

● SYSTEM

$$M\ddot{x} + f(x, \dot{x}) = Bu \quad ; \quad x = \begin{bmatrix} x_a \\ \bar{x} \end{bmatrix}$$

● DYNAMIC CONTROLLER

$$M_c \ddot{x}_c + D_c \dot{x}_c + (K_{c1} + K_{c2}) x_c = -M_c \ddot{x}_a - K_{c2} x_a$$

$$u = -M_c (\ddot{x}_a + \ddot{x}_c) - K_{c2} (x_a + x_c)$$

PHYSICAL INTERPRETATION (Velocity Feedback)

- VELOCITY FEEDBACK IMITATES

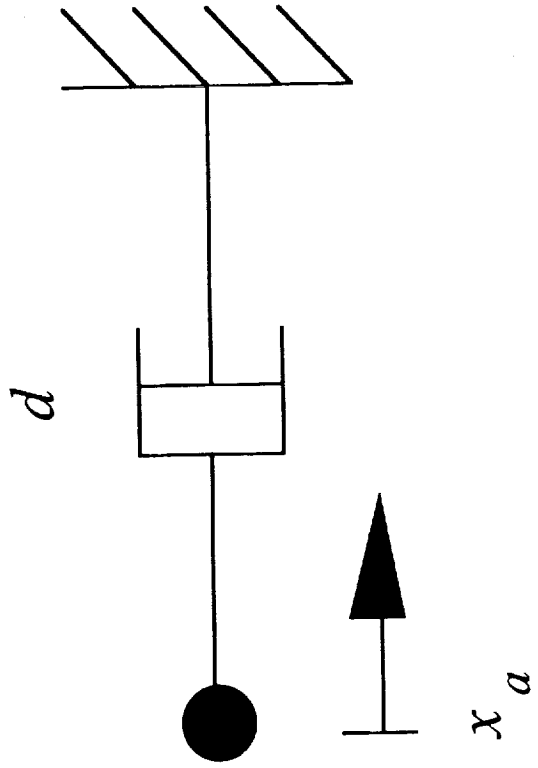

PHYSICAL INTERPRETATION (Displacement Feedback)

- VELOCITY FEEDBACK IMITATES

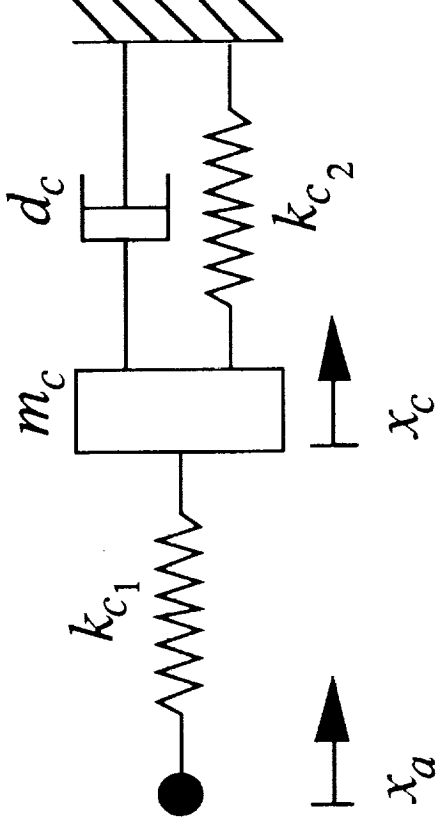

- EMULATION OF VELOCITY FEEDBACK BY MAKING

k_{c1} large, k_{c2} small, m_c small

PHYSICAL INTERPRETATION (Displacement & Acceleration Feedback)

- DISPLACEMENT AND ACCELERATION FEEDBACK IMITATES

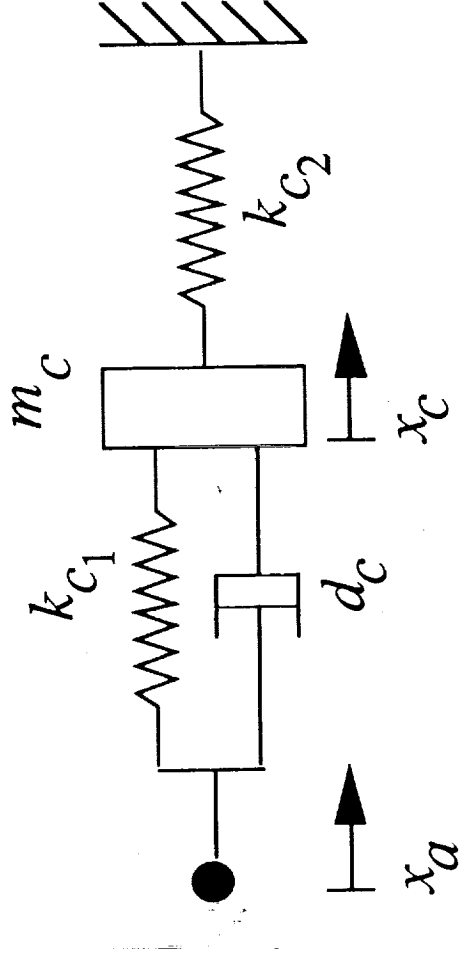

- EMULATION OF VELOCITY FEEDBACK BY MAKING

k_{c1} small, k_{c2} large, m_c small

APPLICATION

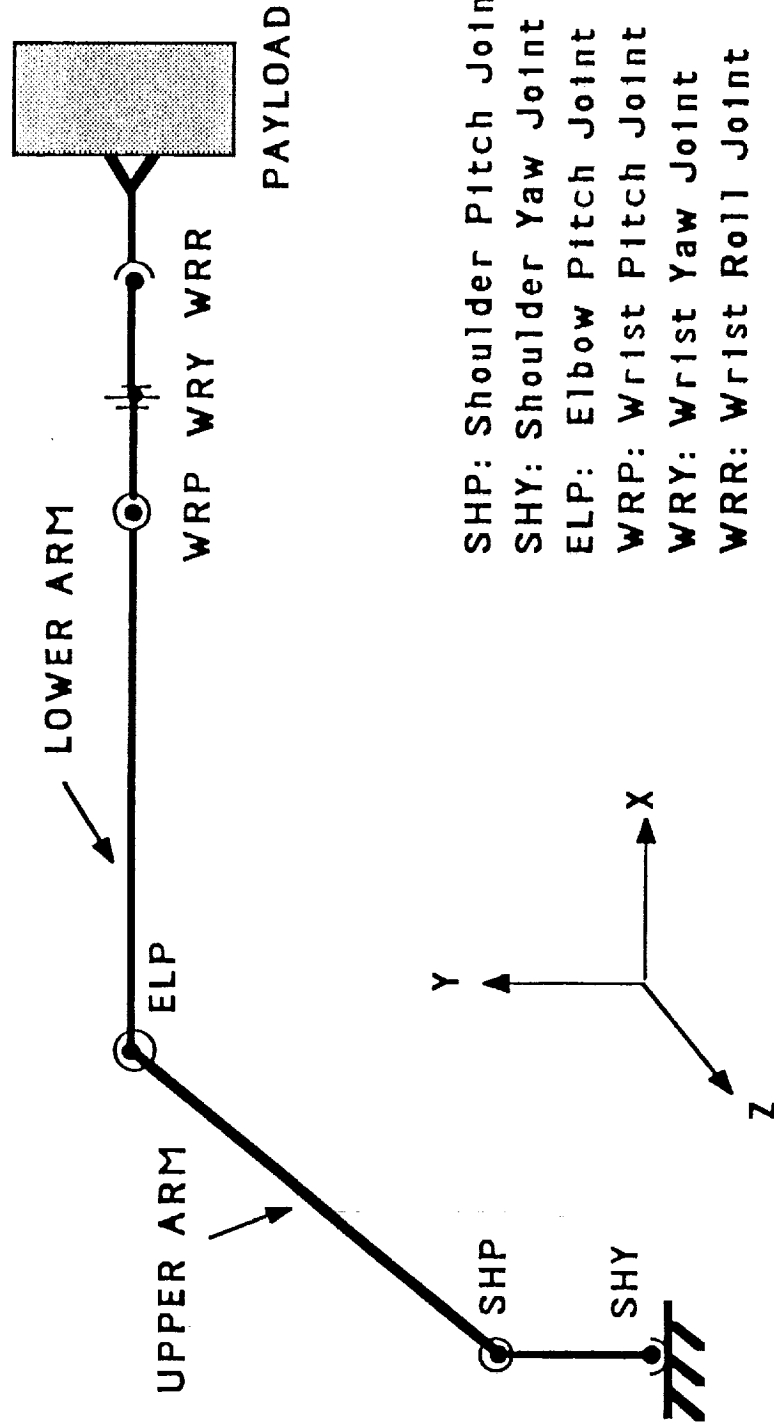

- SHP: Shoulder Pitch Joint
- SHY: Shoulder Yaw Joint
- ELP: Elbow Pitch Joint
- WRP: Wrist Pitch Joint
- WRY: Wrist Yaw Joint
- WRR: Wrist Roll Joint

A Six-Degree-of-Freedom Robot

CASE STUDY

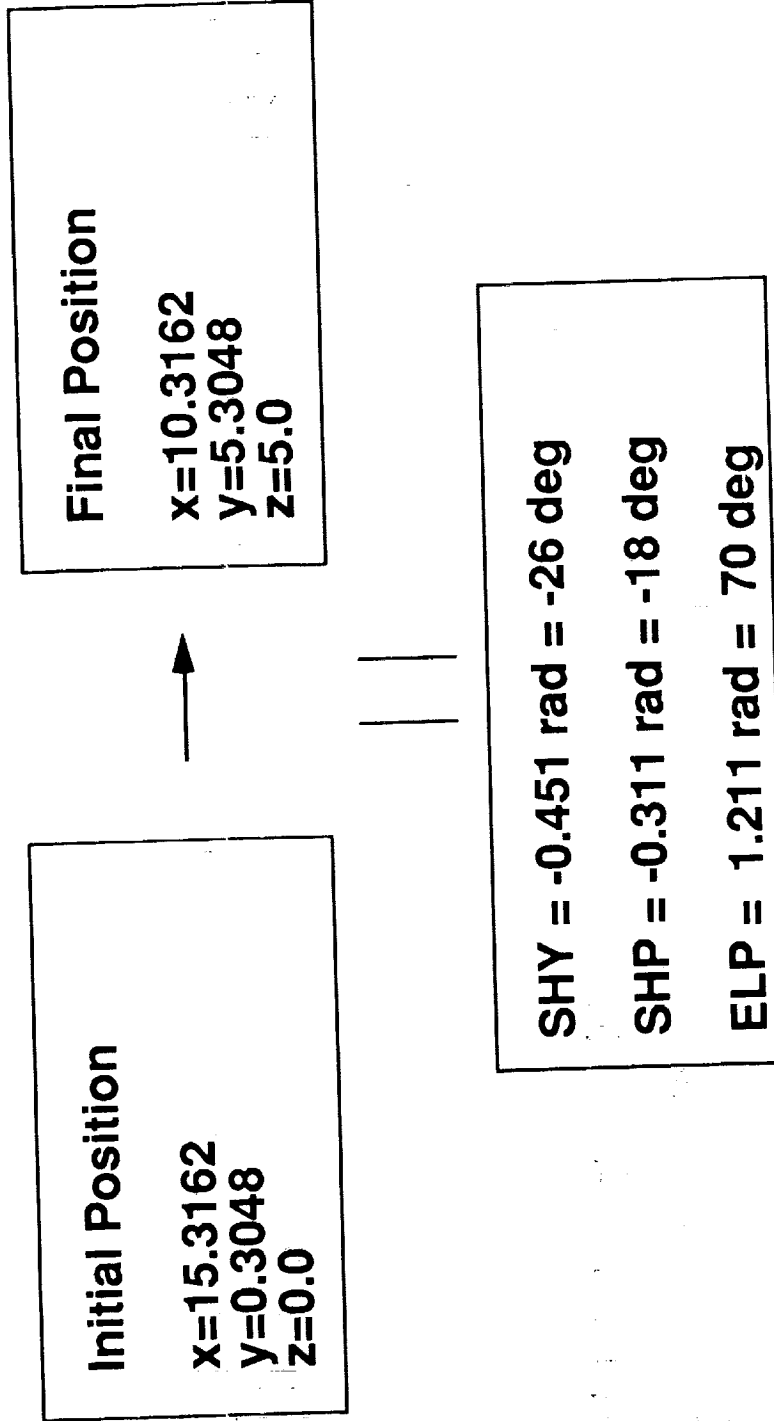

Angular displacement, velocities and/or acceleration of SHY, SHP and ELP joints are used for feedback

CASE STUDY (continued)

- Case 1 :
Displacement and
velocity feedback

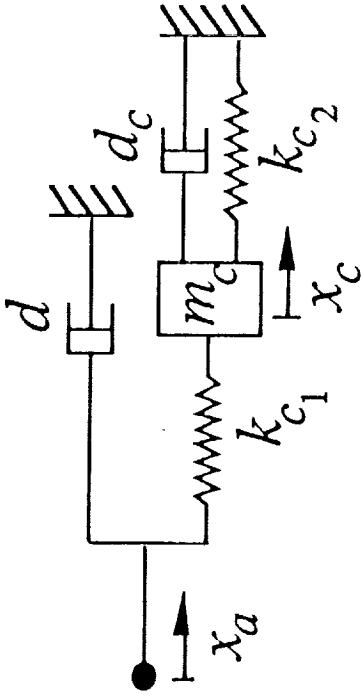

- Case 2 :
Displacement feedback

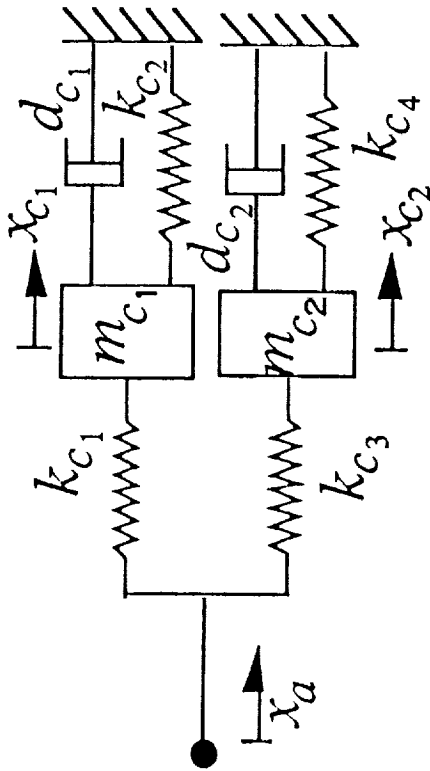

- Case 3 :
Displacement and
acceleration feedback

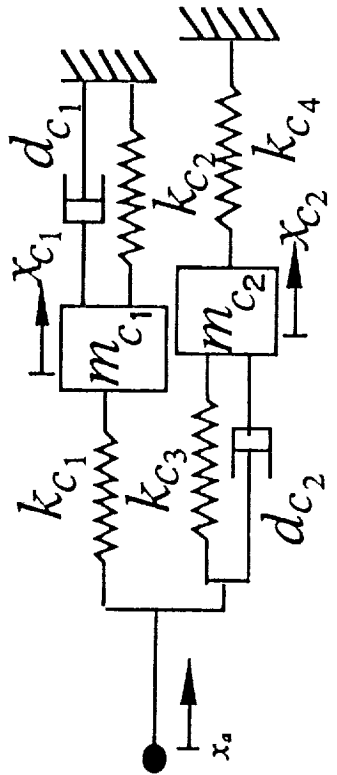

SIMULATION RESULTS

(Displacement and velocity feedback)

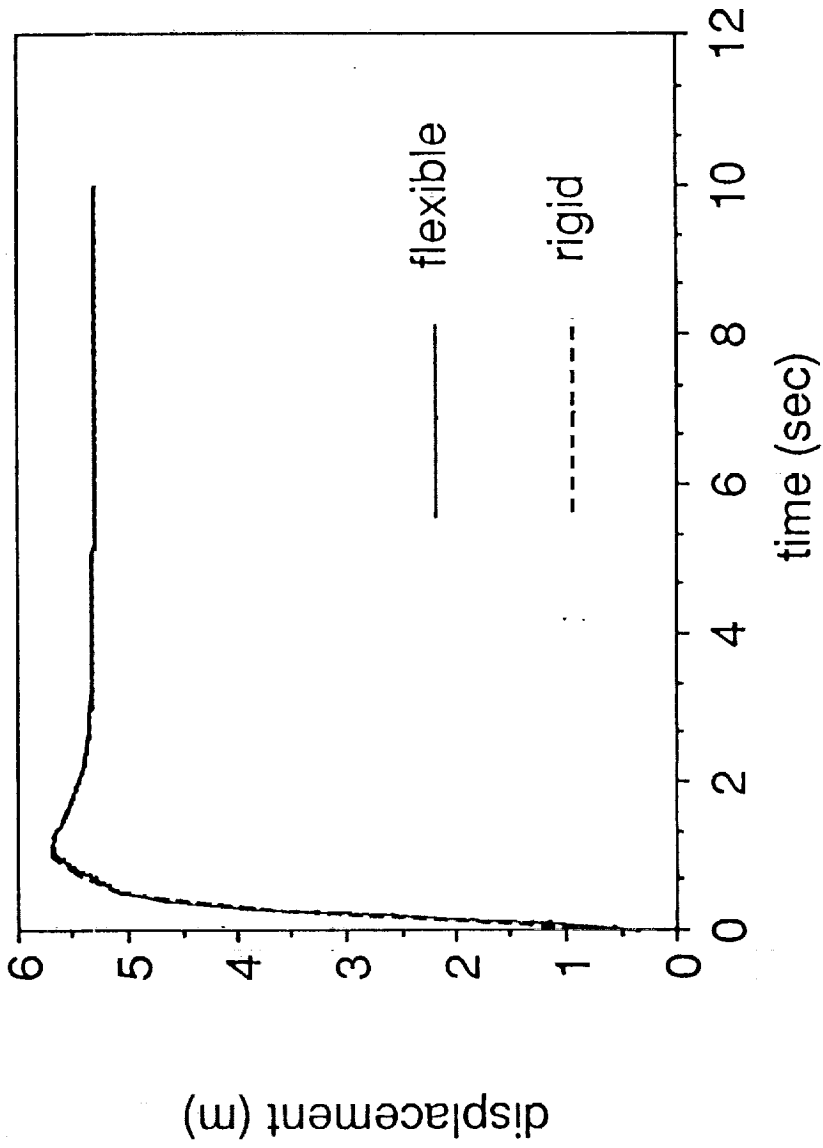

y-Position of the End Effector

SIMULATION RESULTS (Displacement and velocity feedback)

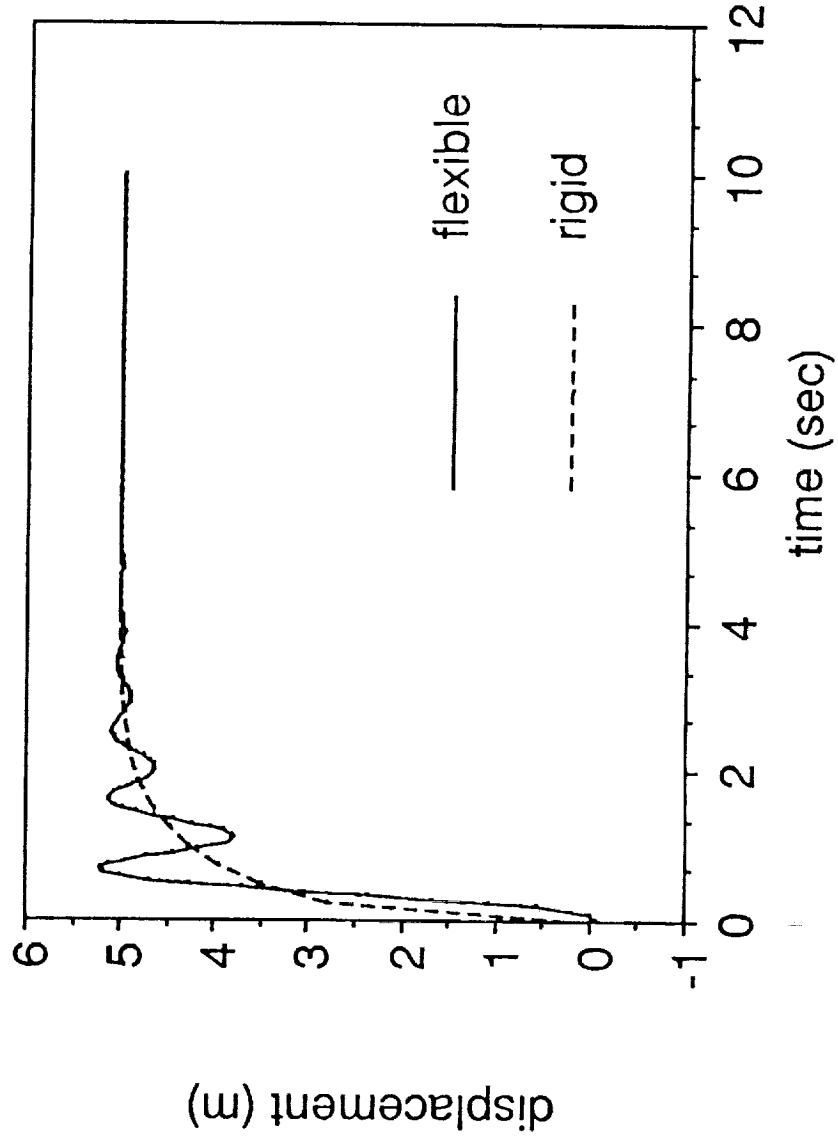

z-Position of the End Effector

SIMULATION RESULTS

(Displacement and velocity feedback)

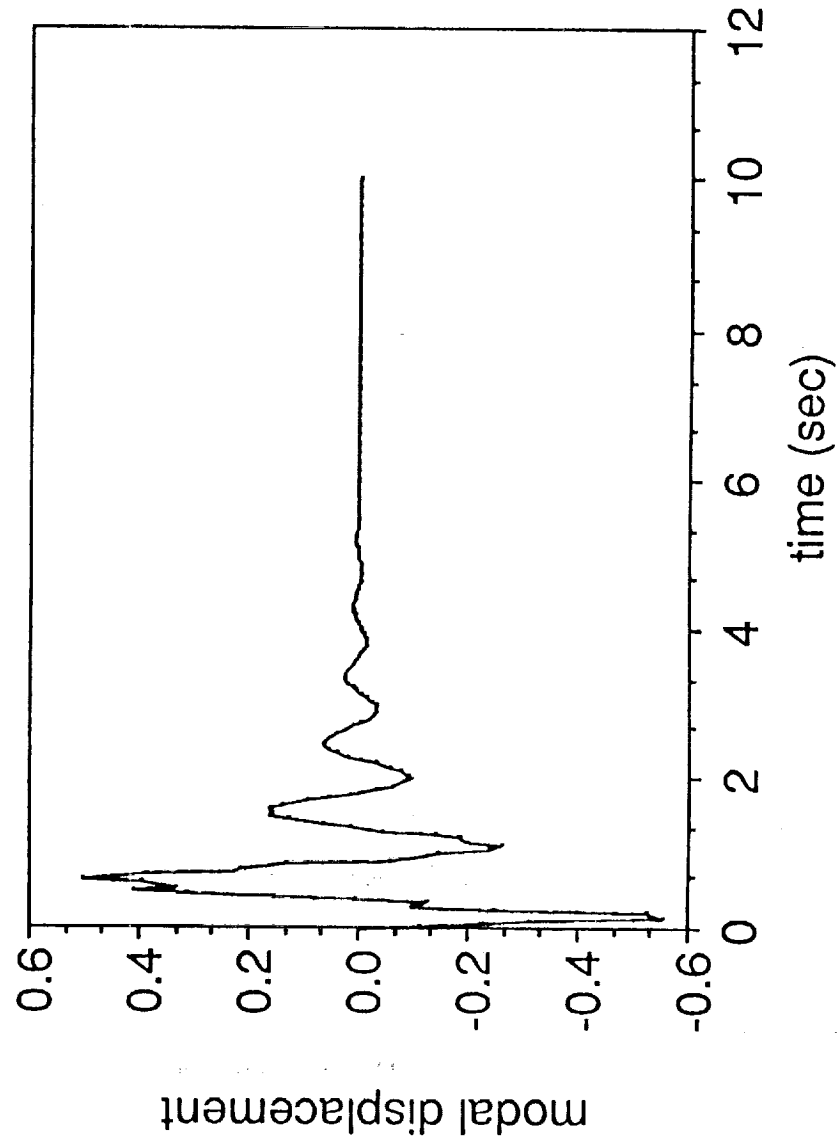

Modal Displacement of First Mode of the Lower Arm

SIMULATION RESULTS (Displacement feedback)

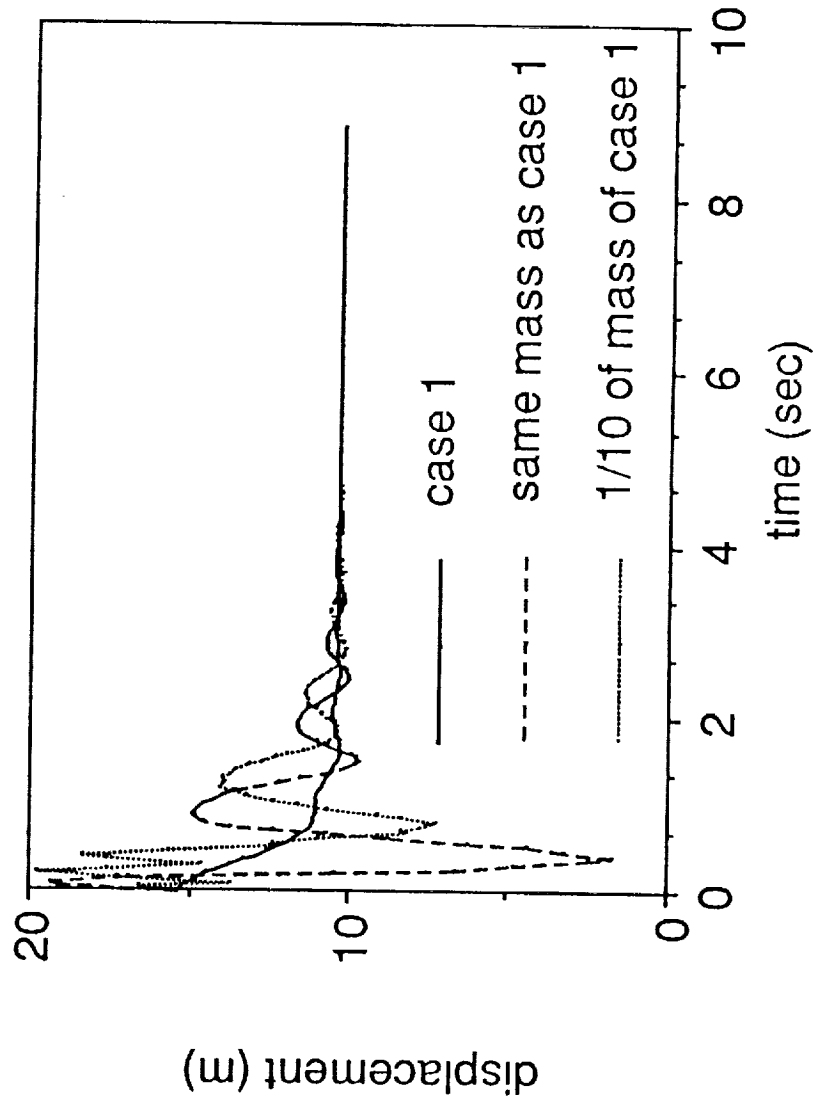

**x-Position of the End Effector for Different Values of
Control mass with Large Control Stiffness**

SIMULATION RESULTS (Acceleration & displacement feedback)

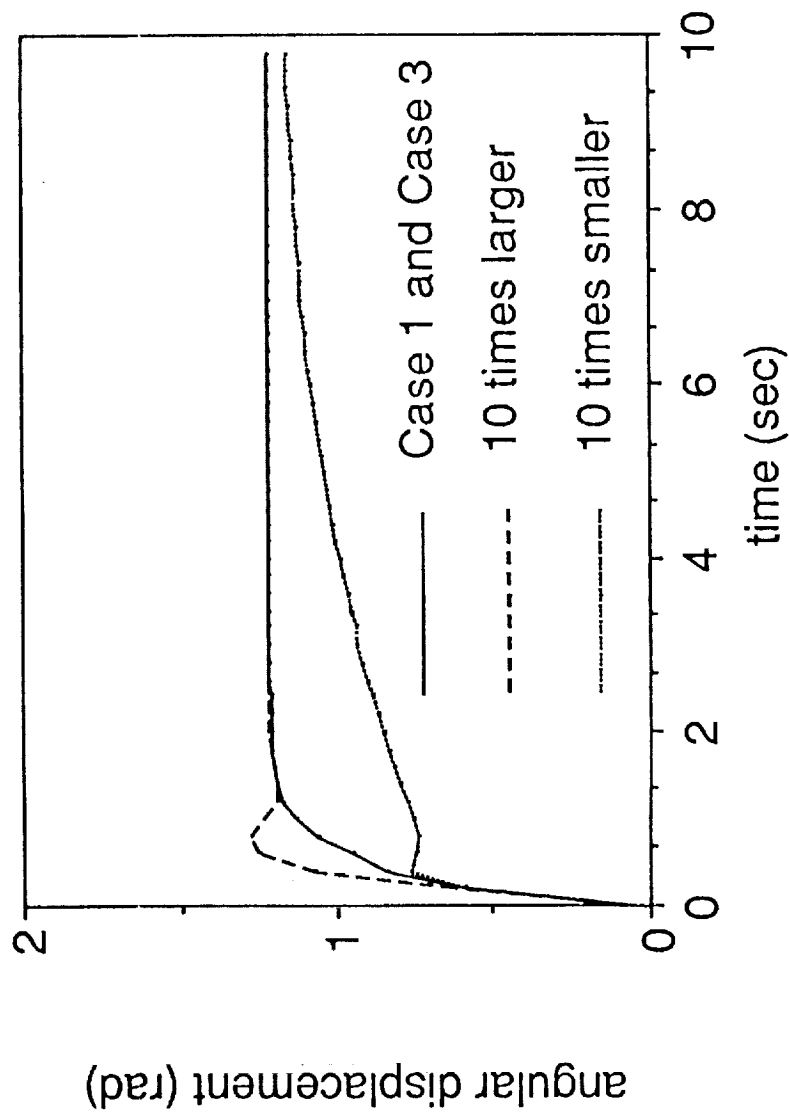

**Elbow Pitch Displacement for Different Values
of Control Stiffness**

SIMULATION RESULTS (Acceleration & displacement feedback)

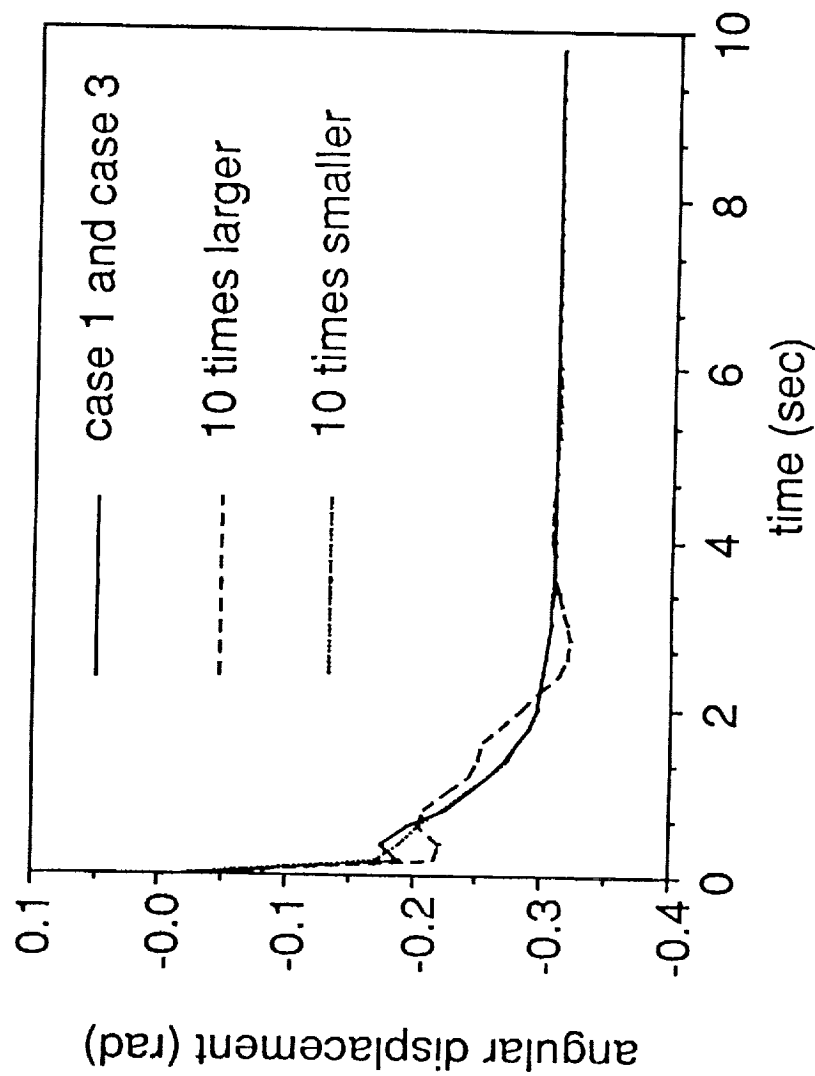

**Shoulder Pitch Displacement for Different Values
of Control Mass**

SIMULATION RESULTS (Acceleration & displacement feedback)

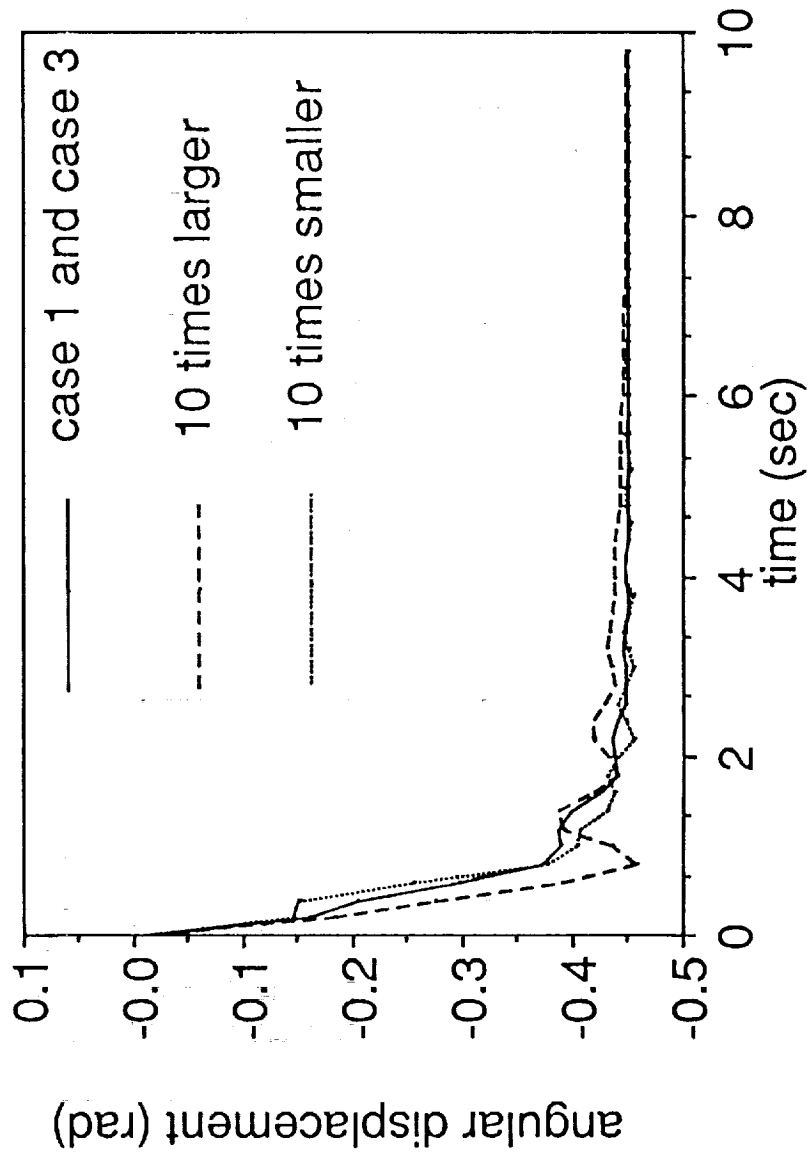

Shoulder Yaw Displacement for Different Values
of Control Damping

CONCLUSIONS

- **A ROBUST CONTROL DESIGN HAS BEEN DEVELOPED**
 - **For large angle position control and vibration suppression**
 - **Applicable to multiple-body flexible dynamic systems**
 - **Model-independent**
 - **Guaranteed stability**
 - **Can use position, velocity, and/or acceleration measurements**
 - **Physical meaning of controller parameters useful for tuning**

REPORT DOCUMENTATION PAGE

Form Approved
OMB No. 0704-0188

Public reporting burden for this collection of information is estimated to average 1 hour per response, including the time for reviewing instructions, searching existing data sources, gathering and maintaining the data needed, and completing and reviewing the collection of information. Send comments regarding this burden estimate or any other aspect of this collection of information, including suggestions for reducing this burden, to Washington Headquarters Services, Directorate for Information Operations and Reports, 1215 Jefferson Davis Highway, Suite 1204, Arlington, VA 22202-4302, and to the Office of Management and Budget, Paperwork Reduction Project (0704-0188), Washington, DC 20503.

1. AGENCY USE ONLY (Leave blank)		2. REPORT DATE May 1992	3. REPORT TYPE AND DATES COVERED Conference Publication	
4. TITLE AND SUBTITLE Automation and Robotics for Space-Based Systems - 1991			5. FUNDING NUMBERS WU 595-11-22	
6. AUTHOR(S) Robert L. Williams II, Editor				
7. PERFORMING ORGANIZATION NAME(S) AND ADDRESS(ES) NASA Langley Research Center Hampton, VA 23665-5225			8. PERFORMING ORGANIZATION REPORT NUMBER	
9. SPONSORING / MONITORING AGENCY NAME(S) AND ADDRESS(ES) National Aeronautics and Space Administration Washington, DC 20546-0001			10. SPONSORING / MONITORING AGENCY REPORT NUMBER NASA CP-10098	
11. SUPPLEMENTARY NOTES				
12a. DISTRIBUTION / AVAILABILITY STATEMENT Unclassified-Unlimited Subject Category 63			12b. DISTRIBUTION CODE	
13. ABSTRACT (Maximum 200 words) A NASA Langley workshop on Automation and Robotics for Space-Based Systems was held on December 10, 1991. This conference proceedings document presents the overhead slides from each speaker at this event. The purpose of this in-house workshop was to assess the state-of-the-art of automation and robotics for space operations from a LaRC perspective and to identify areas of opportunity for future research. The workshop was sponsored by the Guidance, Navigation, and Control Technical Committee, chaired by Mr. Raymond C. Montgomery. Nineteen talks were given, reflecting a high level of interest in the field of automation at NASA Langley. Over half of the presentations came from the Automation Technology Branch, covering telerobotic control, EVA and IVA robotics, hand controllers for teleoperation, sensors, neural networks, and automated structural assembly, all applied to space missions. Other talks covered RMS active damping augmentation, space crane work, modeling, simulation, and control of large, flexible space manipulators, and virtual passive controller designs for space robots.				
14. SUBJECT TERMS Automation, Robotics, Telerobotics, Teleoperation, Manipulator Control, Flexible Manipulators			15. NUMBER OF PAGES 263	
			16. PRICE CODE A12	
17. SECURITY CLASSIFICATION OF REPORT Unclassified	18. SECURITY CLASSIFICATION OF THIS PAGE Unclassified	19. SECURITY CLASSIFICATION OF ABSTRACT Unclassified	20. LIMITATION OF ABSTRACT Unlimited	

