

# Elliptical-Core Two-Mode Fiber Sensors and Devices Incorporating Photoinduced Refractive Index Gratings

Jonathan A. Greene, Mark. S. Miller, Suzanne E. Starr, Brian R. Fogg, Kent A. Murphy, and Richard O. Claus

Fiber & Electro-Optics Research Center  
Bradley Department of Electrical Engineering  
Virginia Polytechnic Institute and State University, Blacksburg VA 24061-0111

Ashish M. Vengsarkar  
AT&T Bell Laboratories, Rm 6D -313  
600 Mountain Avenue  
Murray Hill, NJ 07974

**ABSTRACT:** We present results of experiments performed using germanium-doped, elliptical-core, two-mode optical fibers whose sensitivity to strain has been spatially varied through the use of chirped, refractive-index gratings permanently induced into the core using Argon-ion laser light. This type of distributed sensor falls into the class of weighted-fiber sensors which, through a variety of means, weight the strain sensitivity of a fiber according to a specified spatial profile. In this paper we describe results of a weighted-fiber vibration mode filter which successfully enhances the particular vibration mode whose spatial profile corresponds to the profile of the grating chirp. We report on the high temperature survivability of such grating-based sensors and discuss the possibility of multiplexing more than one sensor within a single fiber.

## 1. INTRODUCTION

The photosensitivity of germanium-doped optical fibers discovered by Hill in 1978 has since been used to introduce permanent refractive-index variations into the cores of both single- and multi-mode fibers for a number of novel sensing and communications applications. Refractive-index gratings in two-mode fibers have been considered as switches (Park and Kim, 1989) and wavelength multiplexing/demultiplexing devices (Oulette, 1991) based on mode conversion which occurs due to a phase-matched condition existing between the index grating and the interference pattern between the two copropagating spatial modes. Although applications for two-mode grating devices have been suggested, no experimental demonstration of a sensor system based on their operation has been found in the literature.

This paper discusses the first sensor system incorporating gratings in two-mode fibers for use in selectively detecting low-order vibration modes in a flexible, cantilever beam. The sensor operates due to the strain sensitivity changes that have been obtained by slightly detuning a two-mode grating with the interference pattern of the light propagating in the core (Vengsarkar *et al.* 1991a). Based on these results, we have developed a method for permanently inducing a strain sensitivity variation (Vengsarkar *et al.* 1991b), or weighting function within the core of an optical fiber which does not involve the structural alterations necessary for other types of vibration mode filters, namely the piezoelectric-shaped (Lee and Moon 1990) and tapered-fiber (Murphy *et al.* 1992) vibration-mode filters.

## 2. TWO-MODE, ELLIPTICAL-CORE FIBER SENSORS

Two-mode, elliptical-core (e-core) fiber sensors operate on the principle of differential phase

(NASA-CR-190495) ELLIPTICAL-CORE TWO MODE  
FIBER SENSORS AND DEVICES INCORPORATING  
PHOTOINDUCED REFRACTIVE INDEX GRATINGS  
(Virginia Polytechnic Inst. and State Univ.)

N92-28868

Unclass

63/74 0105108



modulation between the symmetrical  $LP_{01}$  and asymmetrical  $LP_{11}^{\text{even}}$  spatial modes. When these two modes copropagate solely through the fiber, they generate a spatially alternating interference pattern that evolves along the longitudinal direction with a period equal to the beat length,  $L_B$ , of the fiber. The far-field output pattern consists of two-lobes which exchange power due to strain-induced phase changes that occur between the modes. We typically monitor the light intensity in just one of the output lobes to gauge the strain distributed along the fiber. An expression for the intensity of a single lobe can be expressed as (Vengsarkar *et al.*, 1991c):

$$I_{\text{one lobe}} = I_{\text{dc}} + I_{\text{ac}} \cos[\phi(t)], \quad (1)$$

where  $\phi(t) = \Delta\beta z(t)$  is the time-varying phase difference between the modes,  $\Delta\beta = \beta_{01} - \beta_{11}^{\text{even}}$  is the differential propagation constant for the  $LP_{01}$  and  $LP_{11}^{\text{even}}$  modes, and  $z(t)$  represents the time-dependent fiber length.

The strain sensitivity of two-mode fiber is determined by the differential propagation constant,  $\Delta\beta$ . The differential propagation constant is gauged experimentally by determining the beat length,  $L_B$ , of the two-lobe alternating interference pattern within the fiber. The beat length is defined as the amount by which the fiber must be strained in order for the power in a single output lobe to undergo a complete oscillation. The beat length and differential propagation constant are related by

$$L_B = \frac{2\pi}{\Delta\beta}. \quad (2)$$

## 2. WEIGHTED-FIBER SENSORS

A weighted-fiber sensor is one whose sensitivity to strain varies as a function of length along the sensor. In this way the sensor is able to discriminate between various strain fields within the structure to which it is attached or embedded. Since the differential propagation constant in a weighted-fiber sensor varies as a function of length, it can be expressed as  $\Delta\beta(z)$ . Expressing the time-varying length of the fiber in terms of an integration of local strain in a fiber of length  $L$  we can rewrite the expression for  $\phi(t)$  in the previous section as:

$$\phi(t) = \int_0^L \Delta\beta(z) \epsilon(t) dz, \quad (3)$$

where  $\Delta\beta(z)$  is typically referred to as the *weighting function* of the fiber sensor. In this paper we will consider the one-dimensional case of a two-mode fiber sensor attached to a flexible, cantilever beam of length  $L$ . The longitudinal strain for a thin beam can be expressed as

$$\epsilon(z,t) = \frac{\partial^2 y(z,t)}{\partial z^2}, \quad (4)$$

where  $y(z,t)$ , the transverse displacement of the beam, can be expressed as an infinite sum of cantilever beam vibration mode shapes,  $\Psi_n(z)$ , and mode amplitudes,  $\eta_n(t)$ :

$$y(z,t) = \sum_{n=1}^{\infty} \Psi_n(z) \eta_n(t), \quad (5)$$

Substituting Eqs. (4) and (5) into Eq. (3) and integrating by parts twice, we have



$$\phi(t) = \sum_{n=1}^{\infty} \zeta_n(t) \left( Q(L) + \int_0^L \Delta\beta''(z) \psi_n(z) dz \right), \quad (6a)$$

for a particular mode  $n$ , where

$$Q(L) = \left[ \Delta\beta'(z) \psi_n'(z) \right]_0^L - \left[ \Delta\beta''(z) \psi_n(z) \right]_0^L, \quad (6b)$$

and the primes indicate spatial derivatives with respect to  $z$ . Once the fiber sensor is attached to the structure of interest, the function  $Q(L)$  is essentially a constant.

The key to the weighted-fiber, vibration-mode sensing technique is that the vibration-mode shapes of a thin beam are orthogonal, i.e.,

$$\int_0^L \psi_m(z) \psi_n(z) dz = \delta_{mn}, \quad (7a)$$

where  $\delta_{mn}$  is the Kronecker delta, defined as

$$\delta_{mn} = \begin{cases} 1, & m = n \\ 0, & m \neq n \end{cases} \quad (7b)$$

Comparing the part of Eq. (6a) enclosed by the rectangle to Eq. (7a) we find that if  $\Delta\beta''(z)$  is chosen so that  $\Delta\beta''(z) = \psi_n'(z)$ , except for the constant contribution from  $Q(L)$ ,  $\phi(t)$  will filter out all but the  $n$ th mode for a fiber sensor spanning the entire length of the beam. Hence, if a weighting function for  $\Delta\beta(z)$  is permanently induced within the core such that  $\Delta\beta''(z)$  varies in the shape of a particular vibration mode, fairly mode-specific information can be acquired at the output of the sensor without resorting to conventional analog or digital post-acquisition processing.

### 3. SENSITIVITY CHANGES IN GE-DOPED, TWO-MODE, E-CORE FIBER

We have observed changes in the strain sensitivity of Ge-doped, two-mode, e-core fiber into whose core a permanent index grating has been formed. This is the same photosensitive phenomenon responsible for the formation of Bragg reflection filters within single-mode fibers. In a two-mode fiber, however, the grating is formed from the alternating two-lobe pattern mentioned in the previous section, as opposed to the fringe patterns that occur when two plane waves interfere during the formation of Bragg gratings. In our experiment, a Ge-doped, two-mode, e-core fiber (core dimensions  $1.5 \times 2.5 \mu\text{m}$ , manufactured by Andrew Corp.) was held statically at 1.4 % strain while a grating was formed in the core by injecting an Argon laser beam (40 mW, 514.5 nm) polarized along the major axis of the core ellipse for approximately twenty minutes. Following the high-intensity exposure, the fiber was probed with a low-level laser beam to measure the beat length of the fiber as a function of strain. As shown in Fig. 1, the beat length remains unchanged at strain states a few tenths of a percent away from the exposure strain state, at which point the grating is phase-matched with the probe beam interference pattern. At a phase-matched state, however, mode conversion effects dominate and effectively eliminate the strain sensitivity of the fiber. In a general way, the strain sensitivity has been found to vary according to the degree of mismatch between the grating spacing and the beat length of the interference pattern.

### 4. "WRITING" THE MODE SHAPE INTO THE FIBER

The weighting function necessary to suppress the detection of all vibration modes of a cantilever beam except for a particular mode,  $\Psi_n(x)$ , is obtained by placing the beam, with fiber attached, into the shape of  $\Psi_n(x)$  during exposure. The two-mode grating in the core of the fiber becomes



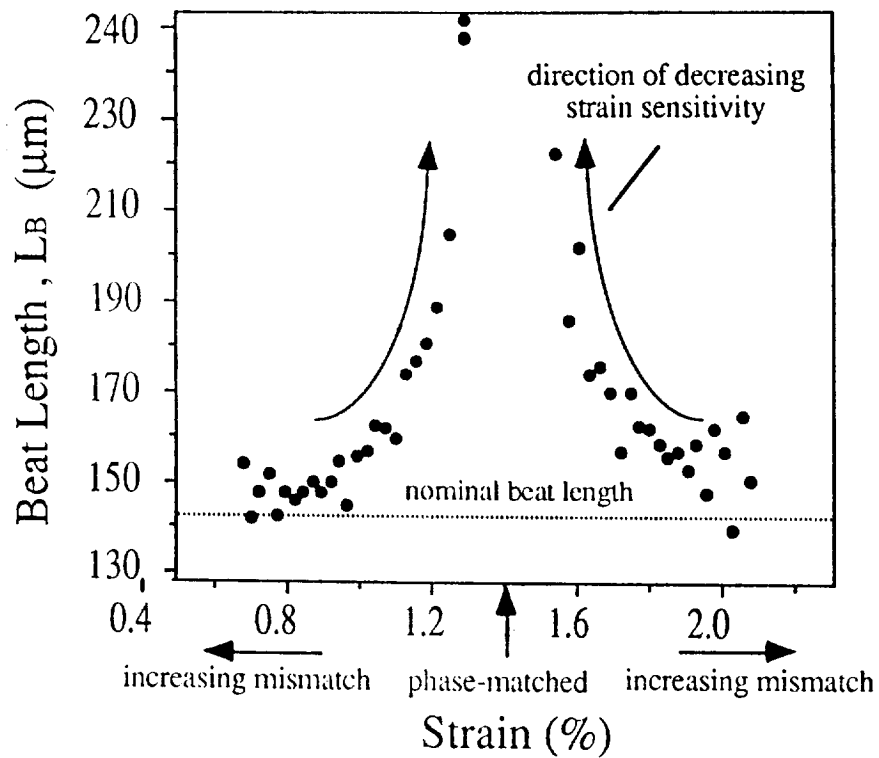

Figure 1. Beat length vs. strain for a two-mode grating formed in a fiber held at 1.4 % strain during exposure.

chirped once the beam is released owing to the unique longitudinal variation in strain for the particular mode. This weighting procedure follows intuitively from an a priori knowledge of the cantilever beam mode shapes and strain distribution.

A step-by-step explanation of the formation process of a grating-based, optical fiber 1<sup>st</sup> mode filter will lend helpful insight into the subtle operating principle of this novel sensor. If a two-mode, Ge-doped fiber attached to a beam held statically in the shape of its first vibration mode is exposed by an Argon laser beam, an index grating forms in the core which will be phase-matched until the beam is released. Releasing the beam causes the grating spacing at the root of the beam to shrink away from a resonance state, while the part of the grating at the tip of the fiber remains in resonance. In terms of the strain sensitivity, before beam is released, all points along the fiber are centered within the resonance region. In this state, the fiber acts like a mode converter and is insensitive to strain at all points along its length. Since the strain for the first vibration mode is concentrated at the root, releasing the beam causes the grating near the root to shrink slightly and the fiber in this region to regain its sensitivity. Since no strain is present at the beam tip, the fiber there remains in a resonance state, effectively desensitized to strain. Hence, a new strain sensitivity profile is attained which renders the fiber selectively sensitive to the first vibration-mode of the beam.

#### 4. EXPERIMENTS: FIBER OPTIC VIBRATION-MODE FILTERS

The experimental set-up used to confirm the predicted, mode filtering capabilities of grating-based vibration-mode filters is shown in Fig 2. An argon-ion laser operating at a single line centered at 514 nm is used to expose a Ge-doped, e-core, two-mode fiber, surface-attached in a loop to a flexible cantilever beam [beam dimensions: thickness: 1.5 mm, width: 35 mm, length:





84.4 cm]. A half-wave plate is used to rotate the polarization of the laser output beam in order to align it with a principle axis of the core ellipse. The output two-lobe pattern is sampled using a pin-hole spatial filter, and then detected with a silicon photodetector attached either to a power meter or a digital oscilloscope.

A piezoelectric transducer (PZT) was attached at the root of the beam to use as a comparison with the fiber sensor. The separate vibration modes, each of which oscillate at different temporal frequencies, were resolved from the output signal of each sensor using the fast-fourier transform (FFT) function on the oscilloscope. Using both channels on the oscilloscope, the 1<sup>st</sup> and 2<sup>nd</sup> vibration modes were monitored simultaneously by both sensors. This arrangement allowed easy comparison between the FFT's of each sensor so that the effectiveness of the fiber vibration-mode filter could be gauged in terms of the relative enhancement of the filtered mode.

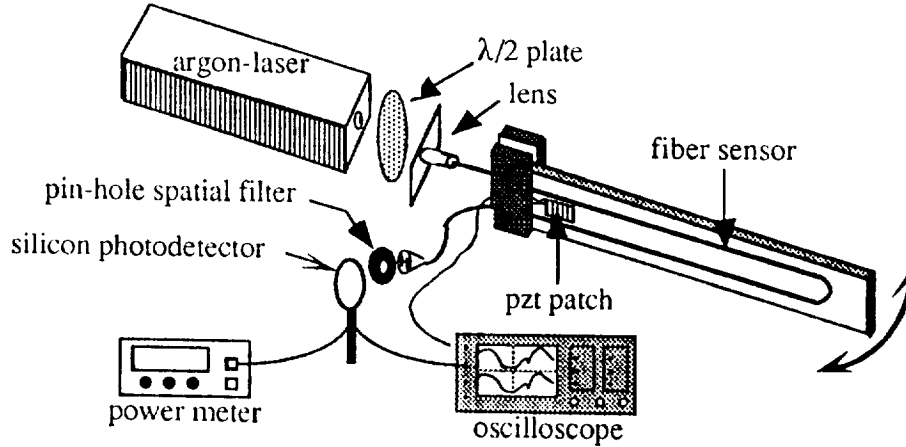

Figure 2. Experimental set-up for fabricating and testing grating-based vibration mode filters

Prior to writing a grating in the fiber, low-power probing of the two-mode fiber sensor provided the vibration mode information for the cantilever beam. The FFT of this signal is shown as the solid line in Fig. 4a. The FFT of the adjacent PZT patch is shown in the figure as the dashed line. Notice that both sensors detect the 1<sup>st</sup> and 2<sup>nd</sup> vibration modes which occur at 1.78 and 11.2 Hz, respectively. An average power of about 40 mW was then sustained in the core of the fiber for about 20 minutes while the beam was held in its approximate 1st vibration mode shape. To obtain an efficient first mode filter, the tip of the beam was held statically in an approximate first mode shape by displacing the beam tip seven inches in the transverse direction.

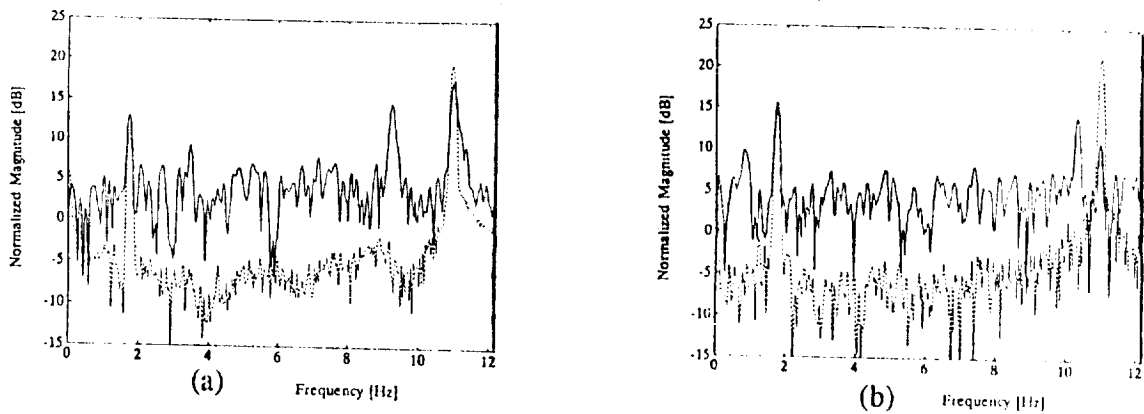

Figure 3. Preexposure (a) and postexposure (b) FFT's for 1st vibration mode filter

After exposure, the beam was released and excited such that both the 1<sup>st</sup> and 2<sup>nd</sup> vibration modes were present. The fiber sensor was then probed with low-level 514 nm light (< 1 mW) to obtain



the FFT shown in Fig. 4b as the solid line. This signal, can be compared to the dashed FFT signal from the piezoelectric patch and also to the FFT's in Fig. 4a to find that the sensor has suppressed the second vibration mode by about 8 dB. Only the relative differences between the modal amplitudes in each figure are compared in order to eliminate any discrepancy arising due to differences in the excitation conditions of each trial.

The experiment was repeated with a fresh piece of two-mode, e-core fiber attached to the beam placed in the shape of its second vibration mode. A comparison of the relative differences between the vibration mode peaks in the pre- and post-exposure FFT's (not shown) indicates first mode suppression on the order of 15 dB.

## 5. POLARIZATION, WAVELENGTH, AND TEMPERATURE PROPERTIES OF GRATINGS

Studies have been conducted to access the polarization, wavelength, and high temperature properties of the two-mode gratings for future device applications. The results from the polarization study indicate that two gratings written within the same fiber, each formed with light polarized along a different principal axis of the core ellipse, are separately resolvable by reading beams of the same polarity. This property could be exploited to multiplex more than one sensor on the same fiber. A two mode grating formed with 514 nm light was probed with a number of Argon laser wavelengths to determine if other wavelengths aside from the writing wavelength exhibited resonance. At the wavelength closest to the writing wavelength, 501 nm, a phase-matched state was observed, however at all other wavelengths, the beat length response to the probing light was either erratic or similar to that of an unexposed fiber. Gratings were exposed to the temperature range 280°-425° C for about an hour to investigate the temperature fading and erasure that has been observed in other types of gratings.<sup>15,16</sup> No effect was made to gratings exposed to the low extreme of this range, however, at 425° all traces of the grating disappeared as indicated by the return of the beat length to its nominal or preexposure value.

## 6. CONCLUSIONS

We have demonstrated a new type of weighted-fiber, vibration-mode sensor whose strain sensitivity weighting function is determined by a permanent index grating photoinduced within the core of Ge-doped, two-mode, e-core fiber. The sensor was tested on a flexible cantilever beam and achieved between 8-15 dB suppression of the 1st and 2nd vibration modes. Studies of the gratings have determined high temperature erasure at 425 °C and the possibility of multiplexing more than one sensor within the same fiber.

## 7. ACKNOWLEDGEMENTS

This work was sponsored in part by the Virginia Center for Innovative Technology.

## 8. REFERENCES

- Lee C K and Moon F C 1990 *J. Appl. Mechanics* **57** 434
- Murphy K A, Fogg B R, Vengsarkar A M to be published in the *Journ. of Light. Tech.*
- Oulette F *IEEE Journal of Quantum Electronics* **27** 797
- Park H G, Huang S Y, and, Kim B Y 1989 *Optics Letters* **14** 877
- Vengsarkar A M, Greene J A, and Murphy K A 1991a *Opt. Lett.* **16** 1541
- Vengsarkar A M, Greene J A, Fogg B R, Murphy K A 1991b *Opt. Lett.* **16** 1707
- Vengsarkar A M, Fogg B R, Murphy K A, Claus R O 1991c *Opt. Lett.* **16** 464

