

NASA Technical Memorandum 104566, Vol. 1

(NASA-TM-104566-Vol-1) SeaWiFS TECHNICAL
REPORT SERIES. VOLUME 1: AN OVERVIEW OF
SeaWiFS AND OCEAN COLOR (NASA) 28 p

N92-29686

Unclas
0109020

G3/48

SeaWiFS Technical Report Series

Stanford B. Hooker and
Elaine R. Firestone, Editors

Volume 1, An Overview of SeaWiFS and Ocean Color

Stanford B. Hooker, Wayne E. Esaias,
Gene C. Feldman, Watson W. Gregg,
and Charles R. McClain



July 1992

The NASA logo, consisting of the word "NASA" in a bold, italicized, sans-serif font.

NASA Technical Memorandum 104566, Vol. 1

SeaWiFS Technical Report Series

Stanford B. Hooker, Editor
*NASA Goddard Space Flight Center
Greenbelt, Maryland*

Elaine R. Firestone, Technical Editor
*General Sciences Corporation
Laurel, Maryland*

Volume 1, An Overview of SeaWiFS and Ocean Color

Stanford B. Hooker, Wayne E. Esaias,
Gene C. Feldman, Watson W. Gregg,
and Charles R. McClain
*NASA Goddard Space Flight Center
Greenbelt, Maryland*



NASA

National Aeronautics and
Space Administration

Goddard Space Flight Center
Greenbelt, Maryland 20771

PREFACE

The Sea-viewing Wide Field-of-view Sensor (SeaWiFS) Project is very important to the ocean and Earth sciences communities. SeaWiFS represents a crucial component in a continuing series of comprehensive observations of the ocean in the visible and near infrared that are required for investigations of the marine biosphere, its variability, marine ecosystem dynamics, oceanic biogeochemical cycles, and the role of the oceanic biosphere in the global carbon system. With SeaWiFS data and correlative data from ships and moorings, scientists will, for the first time, have a complete suite of measurements necessary to study seasonal and interannual variability of oceanic phytoplankton on the ocean basin and on global scales.

The need for a more complete, continuing time series of observations was demonstrated by use of Coastal Zone Color Scanner (CZCS) observations. That proof-of-concept mission, however, lacked the necessary rapid global coverage capability. Research with the CZCS data also pointed out several basic improvements in the areas of calibration and sensor characterization, spectral bands, and radiometric sensitivity, all of which are required for the global applications; these improvements are included with the SeaWiFS system.

NASA has already proposed a follow-on mission, SeaWiFS II, to assure continuation of the time series until data provided by dual Earth Observing Satellite (EOS) Moderate Resolution Imaging Spectrometer (MODIS) sensors in complementary morning and afternoon platforms meets global coverage frequency requirements. The European Space Agency (ESA) has proposed the Medium Resolution Imaging Spectrometer (MERIS) sensor, and Japan is planning to fly their Ocean Color Temperature Sensor (OCTS) on the Advanced Earth Observing Satellite (ADEOS) in 1997. Both of these sensors will make unique and important contributions toward providing the highest possible coverage frequency. These missions will be accompanied by precision altimeters and scatterometers, from which ocean currents and wind forcing of the marine biosphere can be obtained.

The purpose of this series of technical reports is to provide current documentation of the SeaWiFS Project activities, instrument performance, algorithms, and operations. This documentation is necessary to ensure critical information related to the quality and calibration of the satellite data is available to the scientific community. This technical series is not meant to substitute for the scientific literature. Instead, it will provide a ready and responsive vehicle for the multitude of technical reports issued by an operational project.

*Greenbelt, Maryland
June 1992*

— W. E. Esaias

ABSTRACT

SeaWiFS, the Sea-viewing Wide Field-of-view Sensor, will bring to the ocean community a welcomed and improved renewal of the ocean color remote sensing capability lost when the Nimbus-7 Coastal Zone Color Scanner (CZCS) ceased operating in 1986. The goal of SeaWiFS, scheduled to be launched in August 1993, is to examine oceanic factors that affect global change. Because of the role of phytoplankton in the global carbon cycle, data obtained from SeaWiFS will be used to assess the ocean's role in the global carbon cycle, as well as other biogeochemical cycles. SeaWiFS data will be used to help elucidate the magnitude and variability of the annual cycle of primary production by marine phytoplankton and to determine the distribution and timing of spring blooms. The observations will help to visualize the dynamics of ocean and coastal currents, the physics of mixing, and the relationships between ocean physics and large-scale patterns of productivity. The data will help fill the gap in ocean biological observations between those of the CZCS and the Moderate Resolution Imaging Spectrometer (MODIS) on the Earth Observing Satellite-A (EOS-A).

1. INTRODUCTION

It has been apparent to the oceanographic community that due to the dynamic nature of the world's oceans and climate and the importance of the ocean's role in global change, a follow-on sensor to the CZCS, which ceased operations in June 1986, after 7½ years of operation, should be flown. To this end, specifications for an improved ocean color sensor were outlined by the Ocean Color Science Working Group in the 1982 report entitled, *The Marine Resources Experiment Program* (MAREX), and were further refined in the report, *System Concept for Wide Field-of-View Observation of Ocean Phenomena From Space*, written by the Joint Earth Observation Satellite Company (EOSAT)/NASA SeaWiFS Working Group in 1987.

The SeaWiFS Project has been designated by the Office of Space Science and Applications (OSSA) of the National Aeronautics and Space Administration (NASA) Headquarters, and Goddard Space Flight Center (GSFC) to develop and operate a research data system that will process, calibrate, validate, archive, and distribute data received from an ocean color sensor. With support and concurrence of the SeaWiFS Prelaunch Science Working Group (SP-SWG), NASA established a set of criteria for ocean color problems that are summarized in Table 1.

Selection of the SeaWiFS bands was based on historical considerations and the spectral absorption characteristics of some common in-water optical constituents, mean extraterrestrial irradiances, and spectral transmittance of the atmospheric constituents oxygen and water vapor. The relation of these parameters as a function of wavelength is shown in Fig. 1. The data required to accomplish such a mission have been specified by the ocean science community, which will be procured as a data buy from a private contractor, Orbital Sciences Corporation (OSC), who will subcontract with Hughes/Santa Barbara Research Center (SBRC) to build the sensor. OSC will then launch and operate the SeaStar satellite carrying the SeaWiFS sensor.

Table 1. Major instrument parameters and characteristics of the SeaWiFS ocean color sensor.

Band	Instrument Bands			SNR ²
	Wavelength FWHM [nm]	Saturation Radiance ¹	Input Radiance ¹	
1	402-422	13.63	9.10	499
2	433-453	13.25	8.41	674
3	480-500	10.50	6.56	667
4	500-520	9.08	5.64	640
5	545-565	7.44	4.57	596
6	660-680	4.20	2.46	442
7	745-785	3.00	1.61	455
8	845-885	2.13	1.09	467
Sensor Accuracy				
Radiance Accuracy:		<5% absolute each band		
Relative Precision:		<1% linearity		
Between Band Precision:		<5% relative band-to-band (over 0.5-0.9 full scale)		
Polarization:		<2% sensitivity (all angles)		
Nadir Resolution:		1.1 km LAC; 4.5 km GAC		
Mission Characteristics				
Orbit Type:		Sun Synchronous at 705 km		
Equator Crossing:		Noon ±20 min., descending		
Saturation Recovery:		<10 samples		
MTF ³ :		>0.3 at Nyquist		
Swath Width (at equator):		2,801 km LAC (±58.3°)		
Scan Plane Tilt:		1,502 km GAC (±45.0°)		
Digitization:		+20°, 0°, -20° 10 bits		

1. Units of $\text{mW cm}^{-2} \mu\text{m}^{-1} \text{sr}^{-1}$.

2. Minimum values measured at input radiances.

3. Modulation Transfer Function.

The principal objective is to acquire data that is critical for the study of the role of ocean primary production in global biogeochemistry, including the exchange of critical elements and gases between the atmosphere and ocean. Data used for commercial and operational purposes must

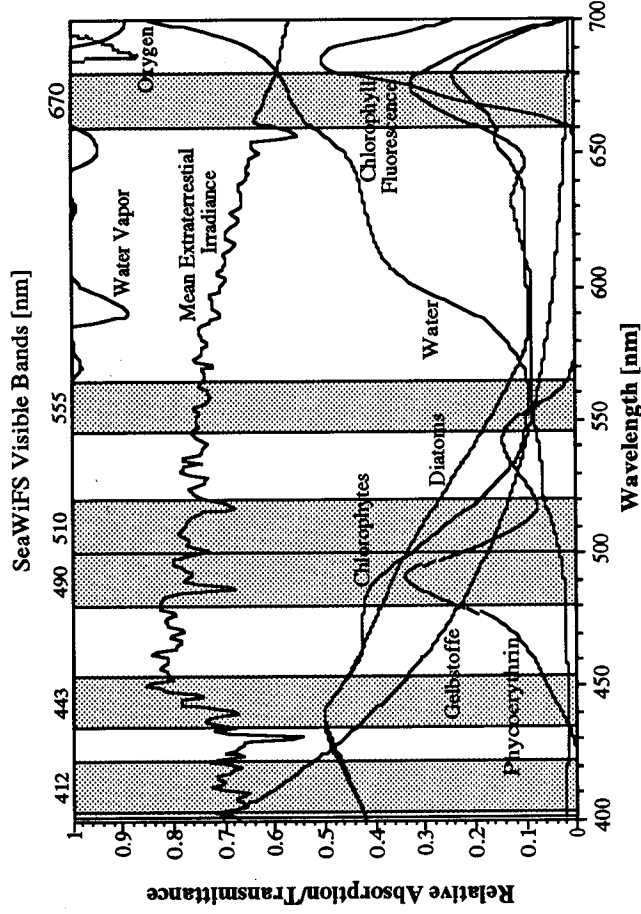

Fig. 1. Spectral absorption characteristics of some common in-water optical constituents, mean extraterrestrial irradiance, and spectral transmittance of the atmospheric constituents oxygen and water vapor, used to select the SeaWiFS visible bands. The bandwidths of the SeaWiFS bands are highlighted (courtesy of W. Gregg).

be purchased directly from OSC. Data used for scientific purposes may be obtained from NASA subject to prior approval by the SeaWiFS Project, with a two-week embargo period. The data will become public domain after five years.

1.1 Ocean Color Requirements

From a scientific perspective, acquisition of ocean color data from space in the early 1990s is a high priority goal that has been recognized in reports of the National Research Council of the National Academy of Science. For example, satellite acquired ocean color measurements are key to the success of the Global Ocean Flux Study (GOFS), a major component of the National Science Foundation's Geosciences initiative. In addition to the U.S. scientific community, scientists from Europe, Japan, and many other countries are also involved through the international Joint GOFS (JGOFS) program.

The scientific uses of ocean color data will be enhanced if the next mission is concurrent with various NASA, European Space Agency (ESA), and Japanese National Space Development Agency (NASDA) missions. For example, the Japanese Ocean Color Temperature Sensor (OCTS), due to be launched in 1996, on the Advanced Earth Observation Satellite (ADEOS) complements SeaWiFS in that it utilizes the same visible spectral bands but also has two thermal bands for sea surface temperature (SST). Additional sensors on ADEOS useful for ocean color objectives are the NASA Scatterometer (NSCAT), which will provide surface winds for data processing and scientific analy-

sis; NASA's Total Ozone Mapping Spectrometer (TOMS); and the French Polarization Detecting Environmental Radiometer (POLDER) for polarization measurements. Data from TOMS and POLDER will be useful for atmospheric correction. The joint U.S.-French TOPEX/Poseidon altimetry mission, due to be launched in July 1992, will provide information on large-scale ocean circulation patterns useful for understanding the coupling between physical and biological patterns of variability.

1.2 Program Goals

The Earth Science and Applications Division of OSSA is committed to the U.S. Global Change Research initiative. Priority areas of research include climate and hydrologic systems, and biogeochemical dynamics. The purpose of SeaWiFS is to examine oceanic biogeochemical factors affecting global change. Because of the role of phytoplankton in the global carbon cycle, SeaWiFS data will be used to assess the ocean's role in the global carbon cycle as well as other biogeochemical cycles. The NASA science goals in support of this undertaking are as follows:

- To determine the spatial and temporal distributions of phytoplankton blooms, along with the magnitude and variability of primary production by marine phytoplankton on a global scale;
- To quantify the ocean's role in the global carbon cycle and other biogeochemical cycles;
- To identify and quantify the relationships between ocean physics and large-scale patterns of productivity;

- To understand the fate of fluvial nutrients and their possible effect on carbon budgets;
- To identify the large-scale distribution and time of spring blooms in the global oceans;
- To acquire global data on marine optical properties, along with a better understanding of the processes associated with mixing along the edge of eddies and boundary currents; and
- To advance the scientific applications of ocean color data and the technical capabilities required for data processing, management, and analysis in preparation for future missions.

The scientific and technical experience gained in the SeaWiFS mission will be invaluable in the preparation for the MODIS mission.

1.3 Project Objectives

The purpose of the SeaWiFS Project is to obtain valid ocean color data of the world's oceans for a five-year period, to process that data in conjunction with ancillary data to meaningful biological parameters, and to make that data readily available to researchers. GSFC will develop a data processing and archiving system in conjunction with the Earth Observing Satellite Data and Information System (EOSDIS), which includes a ground receiving system, and will oversee a calibration and validation effort to ensure the integrity of the final products. The expected launch of SeaStar is in late August 1993. The SeaWiFS Project objectives in support of this undertaking are as follows:

- To serve as the NASA liaison to OSC for the procurement of SeaWiFS data for the oceanographic research community;
- To facilitate the operation and scheduling of the SeaWiFS sensor system;
- To develop and validate algorithms for bio-optical properties and atmospheric correction;
- To characterize and calibrate the SeaWiFS system and to assess on-orbit performance;
- To achieve radiometric accuracy to within 5% absolute and 1% relative, water-leaving radiances to within 5% absolute, and chlorophyll *a* concentration to within 35% over the range of 0.05–50.0 mg m^{-3} ;
- To collect, archive, and process recorded data, as well as global maps of bio-optical properties and chlorophyll *a* concentration, for the research community;
- To provide quality assurance monitoring of, and coordinate collection of, direct broadcast data by NASA's selected research local area coverage (LAC) receiving stations; and

- To support the SeaWiFS Science Working Group (SWG).

1.4 Project Overview

The success of the SeaWiFS mission will be determined by the quality of the ocean color data set and its availability. Inherent in any space flight mission for scientific applications are project functions to assure this success. Figure 2 shows the SeaWiFS Project elements within an end-to-end system overview. The SeaStar satellite broadcasts SeaWiFS data in real time to the GSFC High Resolution Picture Transmission (HRPT) station, as well as to other stations, and recorded data—Global Area Coverage (GAC) and LAC—to GSFC, Wallops Flight Facility (WFF), and OSC. These HRPT, GAC, and LAC data are then transferred to the SeaWiFS Data Processing System (SDPS). SDPS comprises a number of elements, namely: SeaWiFS data processing; calibration, validation, and data quality; data capture; and GSFC mission operations.

The data processing element receives raw spacecraft data and generates standard global ocean color data products. The standard products go to the GSFC EOSDIS Version 0 Distributed Active Archive Center (DAAC), which is responsible for archiving and distributing SeaWiFS data to the scientific community.

The calibration and validation element is responsible for establishing and updating calibration procedures for SeaWiFS data, using correlative data for validating higher-level products; analyzing trends and anomalies; and selecting ancillary data sets that are used in data processing, such as winds, ozone, and atmospheric pressure. Initialization of the spaceborne sensor and continuing algorithm refinement requires *in situ* radiometric measurements that will be made from a marine optical buoy (MOBY) moored off the coast of Hawaii, and dedicated cruises. For the latter, a full suite of supporting measurements will be made including, but not limited to, particle and pigment analysis, sky radiance, and hydrographic and *in situ* spectrometry.

Mission operations serves as the link between OSC and the SeaWiFS Project Office (SPO) for the purposes of reporting problems, monitoring telemetry, and scheduling the scientific aspects of mission operations. It also provides navigation information and orbital elements required for processing and data collection. OSC is responsible for the space segment, mission management, and the command and data acquisition station.

All of the project elements are described in more detail in later sections.

2. RESEARCH APPLICATIONS

Studying the variety of features and scales found within basin circulations from research ships is difficult because of competing temporal and spatial requirements. Small-scale

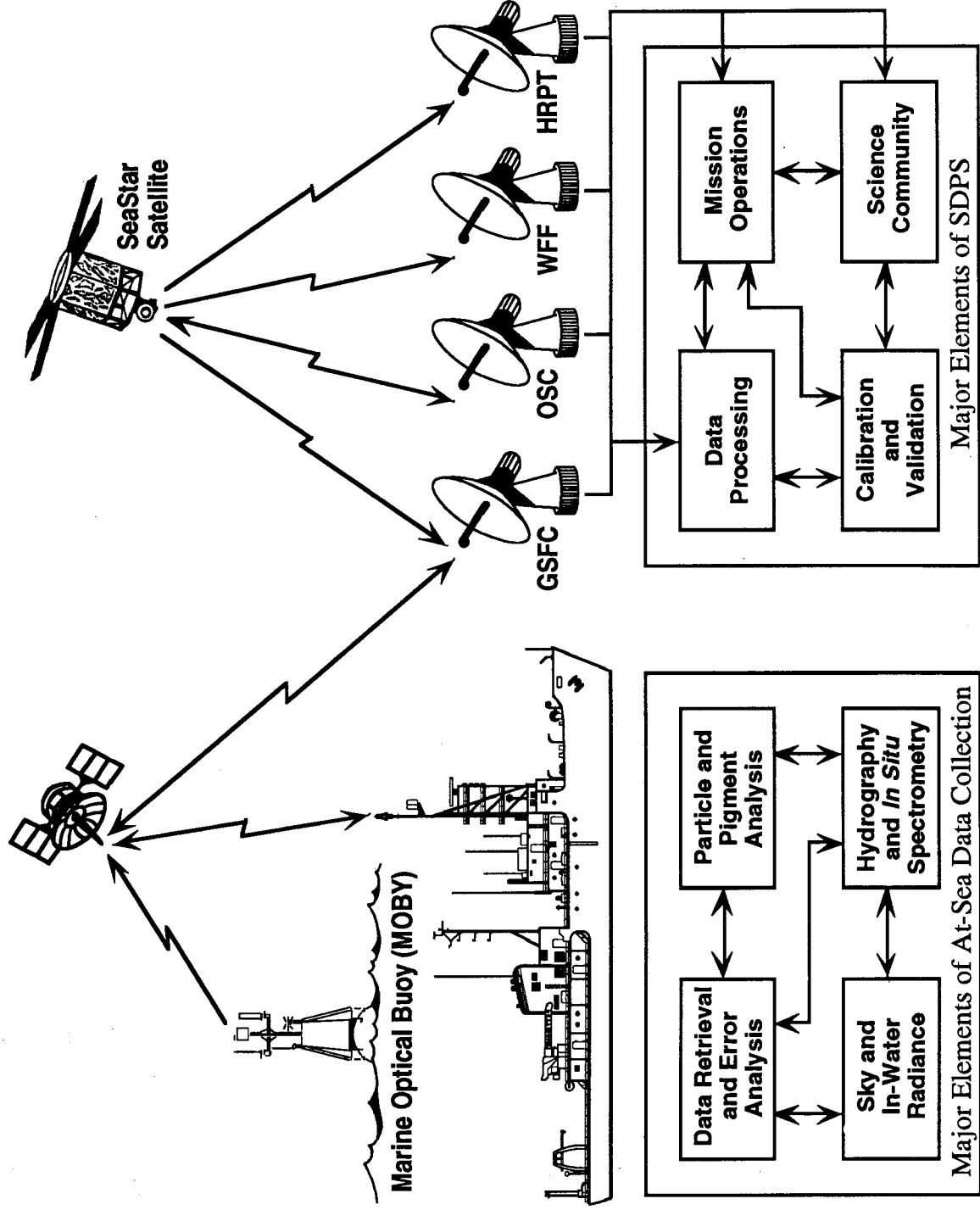

Fig. 2. SeaWiFS Project schematic showing major elements of shore and at-sea data processing.

features (less than approximately 30 km) evolve faster than research vessels can map them. Mesoscale features (approximately 30–150 km) change more slowly, but mapping them from ships is still difficult because of the features' large size. The larger basin-scale circulation is obviously very difficult to map from ships, even with multiple vessels and international cooperation. The dimensions of both small- and mesoscale features are clearly visible in satellite imagery. Frequently, cloudiness effects can be removed using simple compositing techniques. Short-term averaged basin-scale images can be assembled from the individual overpass images and will be a continuing application for satellite acquired ocean color imagery.

Measurements from aircraft and ships in the 1960s, had proven that ocean color is a powerful tool for understanding oceanic, biological, and physical processes and demonstrated it would be possible to use satellites to measure the

spectra of sunlight reflected from ocean waters. For most of the world's oceans, the radiance reflected from the ocean in the visible wavelength region (400–700 nm) is related to the concentration of chlorophyll and other plant pigments. Since chlorophyll is a green pigment and the color of sea water changes from blue to green as the concentration of chlorophyll increases, the amount of phytoplankton in ocean waters can be calculated if the concentration of chlorophyll is known. Thus, satellite acquired ocean color data constitute a powerful tool for determining the abundance of ocean biota on a global scale.

The inversion of radiance to biomass is conceptually straightforward, but not without difficulty. For example, the amount of radiance reflected from the sea surface is very small compared to the atmospheric radiance arriving at the sensor due to Rayleigh scattering. In fact, 90% or more of the signal measured over oceans is due to atmo-

spheric radiance. It is crucial, then, to correct the satellite measured radiance for atmosphere effects if quantitatively useful biomass estimates are to be derived.

The difficulty associated with calibrating and validating a spaceborne color sensor is summarized in Fig. 3 which shows CZCS, SeaWiFS, and MODIS sensitivities compared to water-leaving radiances and radiances measured at the satellite over cloud-free oceans according to model results provided by H. Gordon. The model simulates high latitudes (60° solar zenith angle) at nadir, for a typical atmosphere (0.35 cm ozone, 0.5 cm water vapor, 0.2 optical depth at 670 nm with an Ångström coefficient of 0.5), and for extremely low and high oceanic chlorophyll concentrations (Chl=0.01 and 10.0 mg m⁻³, respectively). Note that virtually the entire range of oceanic chlorophyll concentration is contained within the two lines for at-satellite radiances, requiring a highly stable and sensitive instrument with precise corrections for atmospheric radiances.

Due to a lack of *in situ* observations for comparison, less confidence is ascribed to the model results at wavelengths greater than 700 nm than for the visible. Low Noise Equivalent delta Radiance (NE δ L), defined as the quotient of input radiance to signal-to-noise ratio (SNR) in the red and near infrared region, is especially important for atmospheric correction on a pixel by pixel basis and in turbid waters, and was beyond the capability of CZCS. Instrument sensitivities shown are the NE δ L for the instrument bandwidth, and represent approximately one digital count for SeaWiFS. CZCS values are actual performance measurements, while those for SeaWiFS and MODIS are minimum design specifications. The minimum NE δ L for SeaWiFS was specified to equally apportion errors in derived chlorophyll concentrations between the sensor noise and inherent variability of in-water bio-optical algorithms available in 1983, using the Gordon model. MODIS specifications reflect the minimum expected improvement of both in-water and atmospheric algorithms by 1998.

2.1 CZCS Review

The CZCS was the first instrument to acquire ocean color data from space. It was one of eight experiments on NASA's Nimbus-7 satellite and collected visible radiance data over most of the world's oceans. These data are still being used to study questions concerning the role of the ocean in the global carbon budget and ocean circulation. The major parameters and characteristics of the CZCS are given in Table 2. Although envisioned as a *proof-of-concept* sensor with only four visible spectral bands, limited recorder capacity, and a designed lifetime of about one year, the CZCS provided high quality imagery from the fall of 1978, until the summer of 1986, when the instrument ceased operations. Over its lifetime, the CZCS demonstrated the feasibility of determining phytoplankton pigment concentrations from space. Since it was the only instrument of its kind, its loss was of major consequence to

those interested in research, commercial, and operational applications for ocean color data.

Table 2. Major parameters and characteristics of the CZCS.

Instrument Parameters		Phenomenon
Band	Center	Width
1	443 nm	20 nm
2	520 nm	20 nm
3	550 nm	20 nm
4	670 nm	20 nm
5	750 nm	100 nm
6	11.5 μ m	2.0 μ m
Surface Vegetation		Chlorophyll Absorption
Surface Temperature		Chlorophyll Correlation
		Gelbstoff, Sediments
		Chlorophyll Absorption
		Surface Vegetation
		Surface Temperature
Sensor Accuracy		
IFOV:		0.865 \times 0.865 mrad
Footprint at Nadir:		825 \times 825 m (sea level)
Co-registration:		<0.15 mrad (at nadir)
Viewing Accuracy:		<2.0 mrad (at nadir)
Mission Characteristics		
Orbit Type:		Sun Synch. at 955 km
Ascending Node:		11:52 a.m. (local solar)
Modulation Transfer Function:		1 at 150 km target size, (0.35 min at 0.825 km)
Swath Width:		1,600 km
Scan Plane Tilt:		\pm 20° (in 2° steps)
Digitization:		8 bits

Abbott and Chelton (1991) provide a comprehensive review of the CZCS literature. The use of CZCS data in oceanographic research can be categorized in a variety of ways. The majority of studies published to date have focused on both the spatial and temporal distributions of pigment. The length scales are mesoscale (including regional studies), basin scale, and global scale. In a few cases, only temporal scales are discussed, as with time series at specific locations, and these have usually addressed questions about seasonal and interannual variability, e.g., Dueser et al. (1988) and Dueser et al. (1990). In both papers by Dueser, surface pigment concentrations were correlated with subsurface particle fluxes at various locations in the North Atlantic Ocean.

Another category of research is algorithm development which can be broken down into two groups. The first group focuses on the relationship between water-leaving radiances and other biological or optical parameters such as pigment concentration and diffuse attenuation. These studies rely primarily on field observations and theoretical models. Examples of this group are Austin and Pezold (1981), and Gordon et al. (1983). The second group includes other quantities from the satellite-derived products obtained from the first group of algorithms. Examples of the second group are Eppley (1984), Platt et al. (1988), Campbell and O'Reilly (1988), Kuring et al. (1990), Thompson et al. (1990), and Balch et al. (1992). With the exception of Thompson et al., these studies have focused on estimating

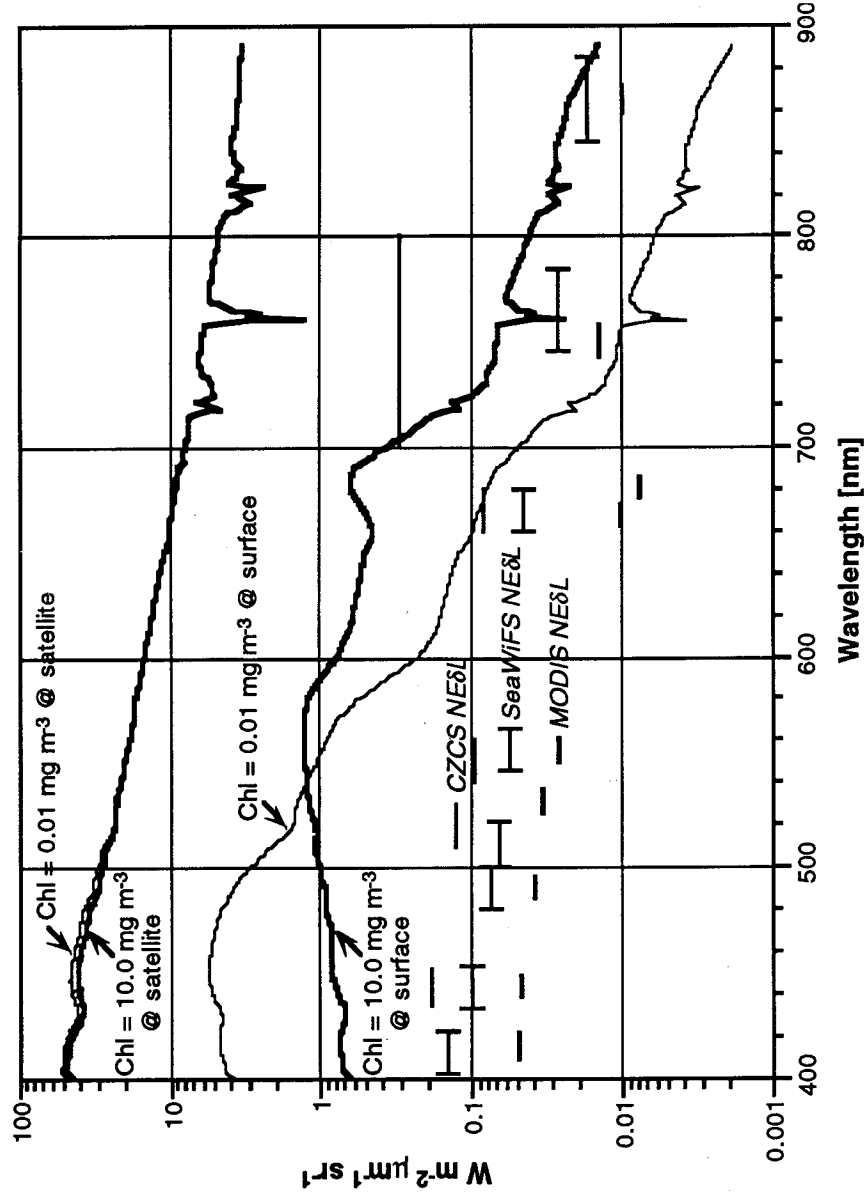

Fig. 3. Spaceborne sensor sensitivities compared to water-leaving radiances, and radiances measured at the satellite over cloud-free oceans according to model results. (Courtesy of H. Gordon.)

primary production from satellite pigment concentrations. Thompson et al. related satellite pigment concentrations to the production of dimethylsulfide in the eastern North Atlantic.

2.2 Mesoscale Processes

With one kilometer resolution, the CZCS provided excellent information on mesoscale processes. Because the CZCS coverage was very inhomogeneous in both space and time (McClain et al. 1992), research using the data has been largely limited to mesoscale phenomena. The majority of studies published have focused on temporal and spatial variability and the coupling between physical and biological processes. The scope of mesoscale studies has ranged from the analysis of a single image showing a particular feature of interest, e.g., McClain and Atkinson (1985), to regional studies involving large numbers of images, e.g., Feldman (1986), McClain et al. (1988), Michaelsen et al. (1988), Mueller and Lang (1989), Strub et al. (1990), and Muller-Karger et al. (1991). Some studies focused on specific processes or oceanic features including river plumes (Barale et al. 1986, Muller-Karger et al. 1989, Muller-Karger et al. 1990), coastal upwelling (McClain et al. 1986, Abbott and Zion 1987), island wake ef-

fects (Feldman et al. 1984), ocean eddies (Gordon et al. 1982, Yentsch and Phinney 1985, Huary et al. 1986), open ocean upwelling (Brock et al. 1991, Brock and McClain 1992) and ice edge processes (Sullivan et al. 1988, Comiso et al. 1990). Other investigations based on time sequences of images provided detailed information on biological processes on bloom event time scales, e.g., Denman and Abbott (1988), McClain et al. (1990a) and Ishizaka (1990a, b, c). Other studies focused on statistical analyses that quantified the scales of spatial variability, e.g., Barale and Wittenburg-Fay (1986), Yoder et al. (1987), and Smith et al. (1988). Examples of mesoscale phenomena are shown in PLATES 1, 2, and 3 (see envelope on back of cover for all PLATES).

2.3 Basin- and Global-Scale Processes

The use of the CZCS data for large-scale studies has not been possible until recently when the global data set was released from NASA/GSFC (Esaias et al. 1986, Feldman et al. 1989). Wroblewski et al. (1988) used a CZCS pigment composite of the North Atlantic to qualitatively verify the results of an analytical model of phytoplankton concentrations in the North Atlantic. Platt and Sathyendranath (1988) used the CZCS pigment fields to estimate basin-

wide primary productivity. McClain et al. (1990b) used the monthly CZCS pigment composites to examine the relationships between physical and biological processes in the North Atlantic. PLATES 4 and 5 show pigment composites of the Arabian Sea (Smith et al. 1991) and the North Atlantic, respectively. Balch et al. (1992) analyzed primary productivity algorithms with respect to a global primary productivity database.

3. NON-RESEARCH USES

The diverse interests of commercial and operational users of remotely sensed ocean data include commercial fishing; marine transportation; offshore oil and gas exploration and extraction; hydrology; marine ecology; naval operations; environmental monitoring; ocean mining; and value-added products, such as fisheries-aids charts. Satellite acquired data on ocean phenomena from the experimental CZCS and the operational Advanced Very High Resolution Radiometer (AVHRR), from which SST maps are routinely derived, have provided the basis for developing a number of important applications serving these interests. The remainder of this section consists of brief reviews of some of the commercial and operational uses of ocean color imagery, presented predominately from the viewpoint of how CZCS imagery was used in this context.

3.1 Commercial Applications

Data on SST, surface currents, and ocean color is useful to the fishing industry in offering the potential for locating fish populations, thereby improving catch efficiency. Maps of remotely sensed oceanic currents are useful to ships at sea to optimize ship routes, thereby reducing costs.

As the world supply of hydrocarbon fuel is steadily depleted, more and more exploration and production is moving offshore into deeper and deeper water. Although offshore moorings and oil platforms are usually designed to withstand the expected currents from eddies, certain operations and hardware are adversely affected that can result in costly delays due to the suspension of various drilling operations. For example, loads on the drill riser, rig movement, remotely operated vehicle activities, and supply vessel operations are all sensitive to mesoscale circulations. Tracking the boundary of eddies and jets is a high priority since it allows these types of operations to continue as long as safety requirements permit.

SST data derived from AVHRR measurements are currently the major sources of the information used in preparing eddy forecasts for offshore oil exploration and production. Temporal changes in eddy size and position and frontal locations are used to produce routine summaries of their positions; surface flow directions; and estimates of their probability, duration, and magnitude.

Unfortunately, the utility of infrared SST measurements significantly deteriorates from the summer through fall in

the Gulf of Mexico and in many other regions at latitudes between 30° south and 30° north, e.g., the equatorial Atlantic and Pacific Oceans, as well as the Indian Ocean. The loss of surface expression occurs because of two separate effects. First, as a result of strong solar heating, surface conditions are relatively isothermal during these months with temperature ranges in the narrow band from about 29–31° C. Second, humid atmospheric conditions cause a severe attenuation of much of the thermal infrared signature. The limitations due to surface heating are greatest when the surface is calm and solar intensity is high. In some instances surface features are completely masked, significantly diminishing the usefulness of the data. Additionally, information on cloudiness and atmospheric aerosols that are computed during atmospheric correction of the data, show promise for use in meteorological investigations and commercial forecasting.

3.2 Operational Applications

Monitoring of ocean dumping, noxious algal blooms and red tides, regional characterization, habitat assessment, flow visualization, and oil spill trajectory analysis are potential operational uses of ocean color identified by the National Oceanic and Atmospheric Administration (NOAA) in the coastal zone.

Within larger estuaries such as the Chesapeake Bay, the frequent coverage will be useful in monitoring turbidity and algal biomass, two major criteria of water quality that relate to the health of submerged aquatic vegetation and the development of anoxia. The accuracy of regional algorithms, based on the standard products but tuned to local conditions using local validation observations, can be much higher than that of the generalized standard NASA algorithms for such applications. While the Instantaneous Field-of-View (IFOV) of SeaWiFS is not ideal for estuaries, the daily coverage frequency more closely matches the inherent time scales in the coastal zone than does Landsat-6 or the French instrument, *Satellite Pour l'Observation de la Terre* (SPOT).

On larger scales, frequent fields of diffuse attenuation coefficient, of interest to studies of upper ocean heat budgets, will likely find use in large scale physical and biological models. The use of ocean color data for flow visualization is analogous to the current use of AVHRR-derived SST for this use. The ocean color data will be especially useful, even mandatory, under conditions when there are weak gradients in SST. These conditions commonly exist at temperate and low latitudes in the summer, and at higher latitudes in the winter. A classic case is the identification of the Loop Current in the summer. The observed ocean color signal integrates over the upper few to tens of meters of the water column. This allows for slight differences in the bio-optical characteristics in underlying waters of the loop current and coastal waters to be readily distinguishable from each other with satellite color observations

at times when the upper centimeters of surface waters are thermally homogenous. This capability is useful for identifying positions of current boundaries such as in routine Gulf Stream frontal analysis, ship routing, and drill rig operations. It also finds applications in oil spill trajectory analysis.

Certain types of ocean dumping activities are also very visible in ocean color data due to slight or profound changes in water bio-optical characteristics. These operational uses generally require near real-time access and dissemination. For many cases, use of climatological or forecast fields of ancillary data will be adequate for immediate use. Retrospective analysis, if required, can make use of the same fields used in retrospective global data processing.

3.3 Joint Commercial Aspects

As part of a contractual agreement between NASA and OSC, NASA retains all rights to SeaWiFS data for research purposes and OSC retains all rights for commercial and operational purposes. The sensor and mission operations are designed to meet the research requirements of NASA. There is a general embargo period of two weeks for distribution of research data by NASA, and a five-year period before the data becomes public domain. There are three exceptions to the embargo period: 1) field experiments requiring data for ship positioning, 2) instrument calibration and validation activities, and 3) demonstrations to prove feasibility for operational use, all of which require prior approval from NASA. During the five-year period, access through NASA will be permitted for research purposes by authorized users only. Access to users for commercial or operational purposes will be through OSC or its licensees. After five years, the data may be used without restriction.

The NASA-OSC contract defines commercial use as those involving the sale or resale of data, as well as data derived therefrom for more than the cost of reproduction. Operational use is defined as real-time or near real-time use of the data, as well as data derived therefrom during the two week embargo period provided above, other than research use expressly authorized by NASA.

The selection of authorized research users will be based on a submission of a brief proposal to NASA. Following approval, users will sign an agreement with NASA stating that the data will be used for research purposes only, and that their distribution will be limited to other authorized users only. The statement will also require signature by users that they will not provide access to data by commercial or operational users.

NASA approved HRPT stations are authorized to receive broadcast LAC data by NASA. These stations will also be committed to distributions of data only to authorized users. Normally, this authorization will be for retrospective use, meaning decryption codes will be provided at least 14 days after reception. LAC data will have to be recorded for later decryption.

In addition to the GSFC LAC facility, up to 12 stations at any given time may be licensed by NASA for near real-time support for specific time periods and purposes, and may receive the decryption key in advance. Criteria for designating stations for rapid response include station coverage of scientific cruises or experiment areas, technical capability, and performance. It is expected that this designation and scheduling of assignment periods, will be reviewed at least annually by a panel convened by NASA in order to assure optimal coverage of experimental sites and times. As in the case for research users, approval by NASA can be revoked at any time if the non-disclosure agreement is violated. This will guarantee that the SeaWiFS data will be distributed by NASA only to authorized users for research.

NASA will also notify users of updates to calibration and revisions in the processing algorithms or ancillary data used for producing the SeaWiFS products. This will occur through an electronic bulletin board.

4. SPACECRAFT DESCRIPTION

The SeaStar spacecraft, developed by OSC, will carry the SeaWiFS instrument and will be launched to low Earth orbit on board an extended Pegasus launch vehicle. The SeaWiFS instrument will be the only scientific payload on the SeaStar spacecraft. OSC has the sole responsibility for the development, launch, and command and control of the satellite. The development of the SeaWiFS instrument was subcontracted to Hughes/SBRC, but OSC maintains ultimate responsibility for the instrument.

Currently, the Pegasus is flown aloft under the wing of a modified Lockheed L-1011 aircraft and released at an altitude of about 39,000 ft, whereupon the launch vehicle engages and lifts the spacecraft to a low Earth, circular, parking orbit of 278 km with an inclination of 98.20°. The launch sequence is shown in Fig. 4. The solar panels are deployed at this time (see Fig. 5), which along with the NiH₂ batteries, are the sensor's power source. The solar panels provide an end-of-life power production of 170.27 W averaged over the orbit.

The SeaStar spacecraft has an onboard hydrazine propulsion system that is then used to raise the satellite to its final 705 km circular, noon, sun-synchronous orbit. The final orbit is reached approximately 20 days following launch. The launch is presently planned to occur from the U.S. West Coast during daylight hours, although launch from the East Coast is under consideration if an L-1011 is used. At 25 days after launch, the SeaWiFS instrument is powered up and checked out. At launch plus 30 days, data collection operations commence. The overall sequence of launch to operational system is shown in Fig. 6.

The attitude control system (ACS) must be capable of maintaining the 705 km noon, sun-synchronous orbit, performing lunar and solar calibration maneuvers, and providing attitude knowledge within one SeaWiFS pixel. The

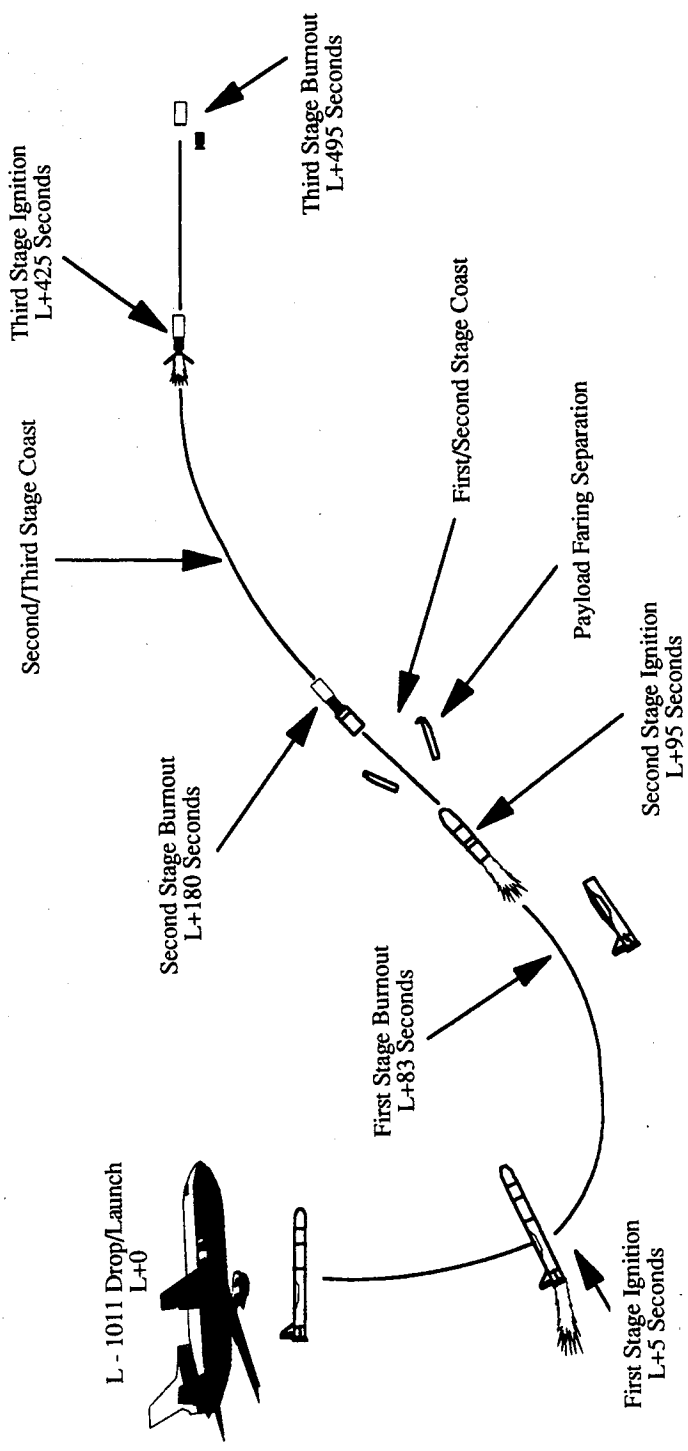

Fig. 4. SeaStar launch sequence.

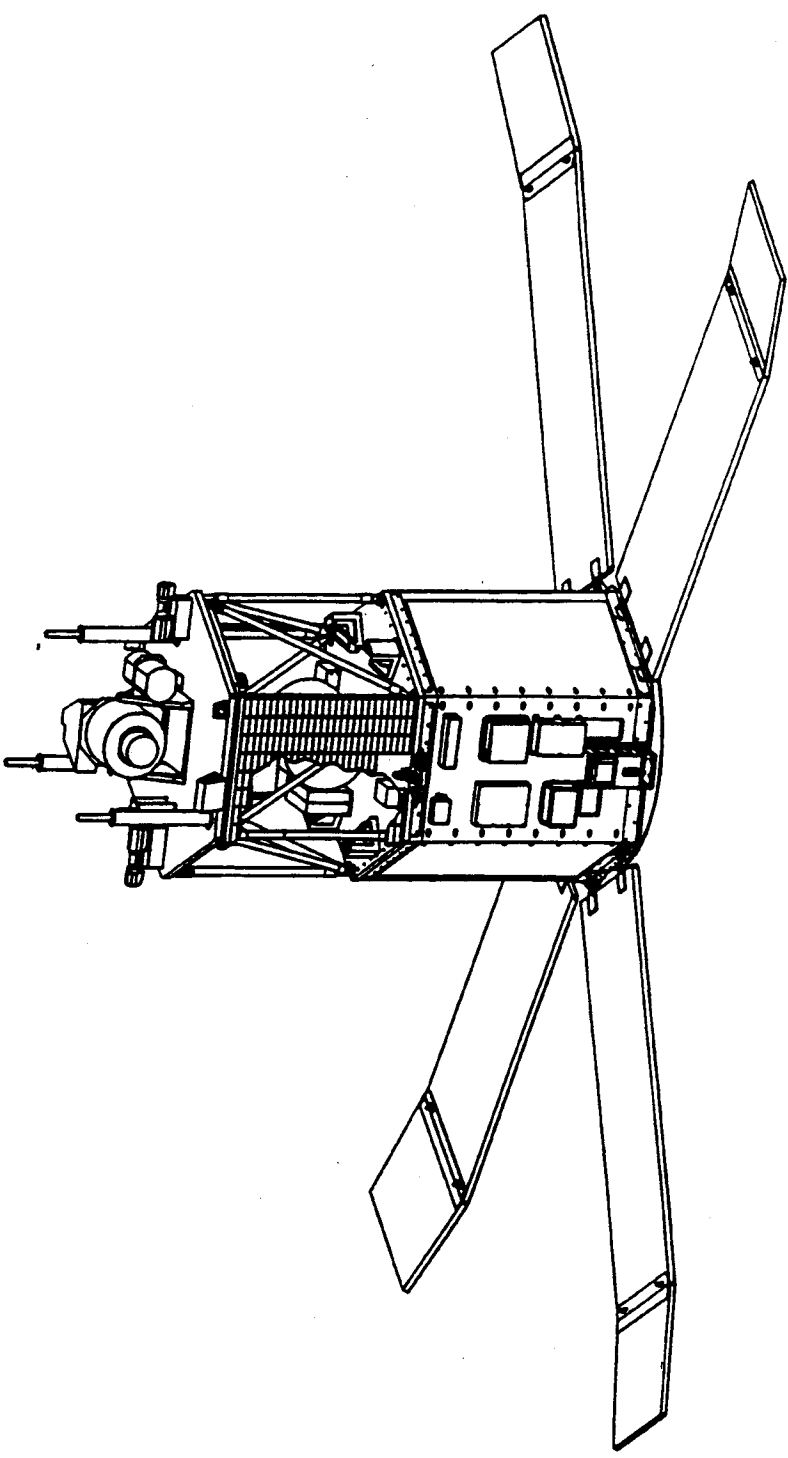

Fig. 5. SeaStar satellite with solar panels deployed.

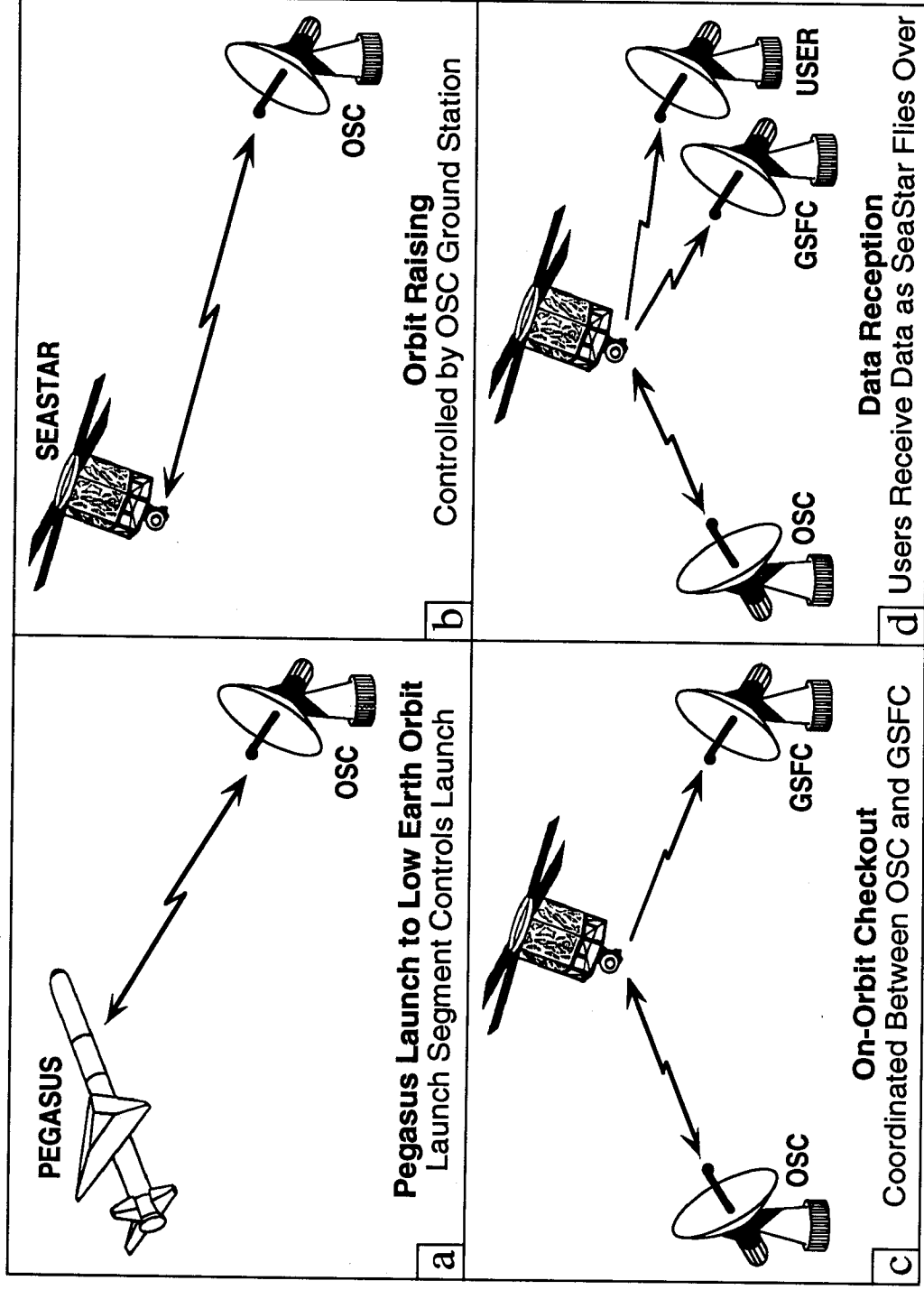

Fig. 6. SeaStar operational system.

three-axis stabilized system consists of orthogonal magnetic torque rods for roll and yaw control and two momentum wheels for pitch stabilization. Sensors include redundant sun sensors, horizon sensors, and magnetometers.

The propulsion system consists of two subsystems, a reaction control system, and a hydrazine propulsion system. The reaction control system uses nitrogen and provides third stage stabilization during the launch. The hydrazine propulsion system is used for raising the orbit from the nominal 278 km parking orbit to the 705 km synchronous operational orbit. In addition, it is used for orbit trim requirements over the life of the mission. Four Hamilton Standard one pound thrusters are being used.

Two telemetry streams are transmitted. The first is real-time LAC data merged with spacecraft health and instrument telemetry at 665.4 kbps. This is transmitted at L-band with a frequency of 1702.56 MHz. The other telemetry stream consists of stored GAC and selected LAC, along with spacecraft health and instrument telemetry, at 2.0 Mbps. This is transmitted at S-band with a frequency of 2272.5 MHz. The command system uses S-band with an

uplink of 19.2kbaud at 2092.59 MHz.

Redundant global positioning system (GPS) receivers will be used for orbit determination. The orbit state derived from this is included in the spacecraft health telemetry. There are no plans to use the Tracking and Data Relay Satellite System (TDRSS) for this Project.

5. SENSOR DESCRIPTION

The original thought was that the sensor would be built by Hughes/SBRC and launched by the EOSAT on board Landsat-6. However, the contract negotiations were not completed. Subsequently, a competitive request for proposal (RFP) was issued in November 1990. After review of the submitted proposals, OSC was selected to provide the ocean color data, and a contract was awarded on March 29, 1991. OSC will thus build, launch, and operate the SeaStar spacecraft, which will carry the SeaWiFS instrument built by Hughes/SBRC. Much was learned from the CZCS experience in terms of calibration requirements, sensor design, algorithm design, data processing, and scientific

applications. SeaWiFS will be able to take full advantage of this experience.

The SeaWiFS instrument consists of an optical scanner and an electronics module. A cut-away drawing of the scanner is shown in Fig. 7. The instrument has scanning mechanisms to drive an off-axis folded telescope and a rotating half-angle mirror that is phase-synchronized with, and rotating at half the speed of, the folded telescope. The rotating scanning telescope, coupled with the half-angle scan mirror arrangement, provides a design configuration that permits a minimum level of polarization to be achieved, without field-of-view rotation, over the maximum scan angle requirement of $\pm 58.3^\circ$. The absence of field-of-view rotation permits the use of a multichannel, time-delay and integration (TDI) processing in each of the eight spectral bands to achieve the required SNR. This capability, in turn, allows a relatively small sensor collecting aperture and, therefore, results in a smaller and lighter instrument than would otherwise be required.

Incoming scene radiation is collected by the folded telescope and reflected onto the rotating half-angle mirror. The collected radiation is then relayed through dichroic beam splitters to separate the radiation into four wavelength intervals—each wavelength interval encompassing two each of the eight SeaWiFS spectral bands. The radiation in the four separate wavelength intervals is directed by four corresponding aft-optics assemblies through two separate spectral bandpass filters that further separate the radiation into the eight required SeaWiFS spectral bands. The aft-optics assemblies also image each of the resultant defined bands of radiation onto four detectors that are aligned in the scan direction. The detected radiation signals are then amplified by preamplifiers for TDI processing in the electronics module.

The off-axis scanning telescope rotates at six revolutions per second in the cross-track direction, for HRPT format compatibility, to provide contiguous scan coverage at nadir from a 705 km (380 nmi) orbital altitude with the SeaWiFS spatial resolution of 1.6 mrad (1.13 km or 0.6 nmi at nadir). A scanner tilt mechanism enables the instrument to be oriented in the along-track direction to -20° , 0° , and $+20^\circ$ to avoid sun glint from the sea surface. Tilting the entire scanner, rather than only a section of the optical train, assures that the SeaWiFS calibration, polarization, and angular scanning characteristics will be identical for all tilt positions and, thereby, simplifies the ground processing of in-flight data.

Monitoring of sensor calibration over periods of a few orbits, to several months or years, is accomplished using solar calibration for the former and lunar calibration for the latter. Solar calibration uses a solar radiation diffuser and an input port located in a fixed position outside of the ± 58.3 degrees SeaWiFS scene-scan interval. The diffuser is located on the inside of a baffle pointed in the $+y$ (minus velocity vector) direction. The diffuser will be covered with an aperture plate with numerous small holes that will

adjust the diffuser system output to the required level and minimize diffuser surface degradation from contamination or ultraviolet exposure. The diffuser is located so calibration will take place near the southern terminator.

Lunar calibration is accomplished by a spacecraft maneuver to view the moon when the spacecraft is in the nighttime part of the orbit. The spacecraft is oriented such that the SeaWiFS scene-scan interval is 180° from the normal Earth oriented position, i.e., looking outward. The lunar observation can, therefore, be accomplished under nearly full moon conditions through the identical SeaWiFS optical path as that for Earth scenes.

The detected and amplified signals are routed from the scanner to the electronics module where they are further amplified and then filtered to limit the noise bandwidth. The filtered signals are digitized by a 12 bit analog-to-digital converter and the digitized signals directed to a commandable processor where the TDI operation is performed in real time as data are generated. The resultant summed signals are divided by four and rounded to 10 bit numbers, and then sent from the processor to the spacecraft data system at 1.885 Mbps during the data acquisition period of each scan line.

The instrument angular momentum will be compensated by the angular momentum wheel. This is necessary to avoid nutation coupling when the instrument is tilted. Implementation will consist of a brushless DC motor driven synchronously at approximately 2,000 rpm. The accurately controlled frequency derived from the instrument clock will ensure compliance to the 1-oz-in-sec uncompensated angular momentum requirement for the spacecraft attitude control system.

The key sensor performance parameters, required performance, and predicted performance, are listed in Table 1. The SeaWiFS design will meet or exceed the required performance values.

6. DATA MANAGEMENT

Figures 8 and 9 show the SeaWiFS system elements within a detailed overview. Conceptually, the system divides into two parts: the Space Segment including the Ground Support System (Fig. 8) and the SeaWiFS Data Processing System or SDPS (Fig. 9). OSC is responsible for the Space Segment, the Mission Management, and their Command and Data Acquisition Station. Figure 8 shows the SeaStar satellite downlinking SeaWiFS real-time HRPT data to the GSFC HRPT station, and other approved stations, as well as GAC and LAC data to GSFC, WFF, and OSC. The HRPT, GAC, and LAC data are then transferred to the SDPS.

SeaWiFS Data Processing System: This element receives raw science data and generates the global ocean color data products. Within this element are separate development, test, and production environments. Standard products will be provided to

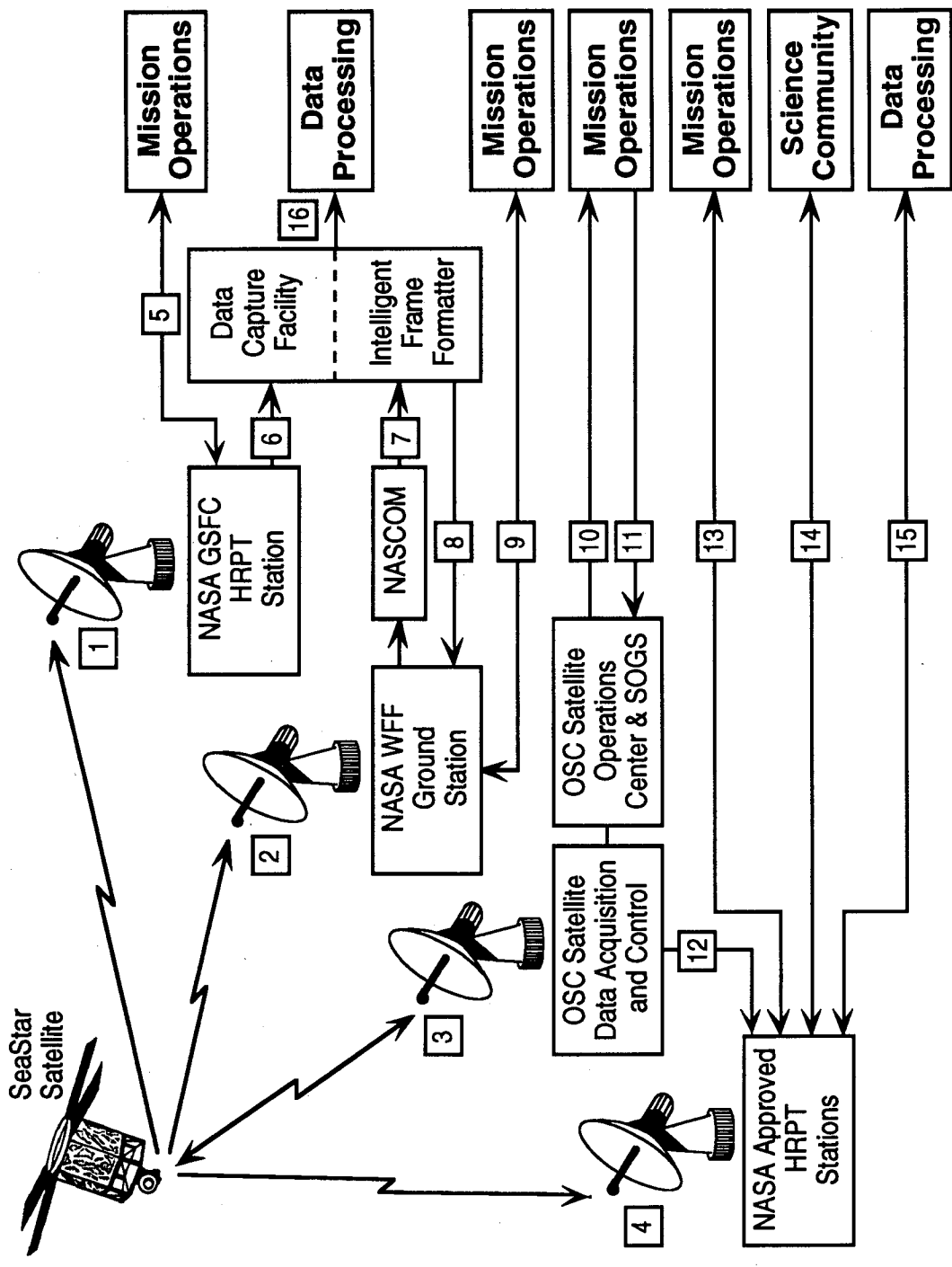
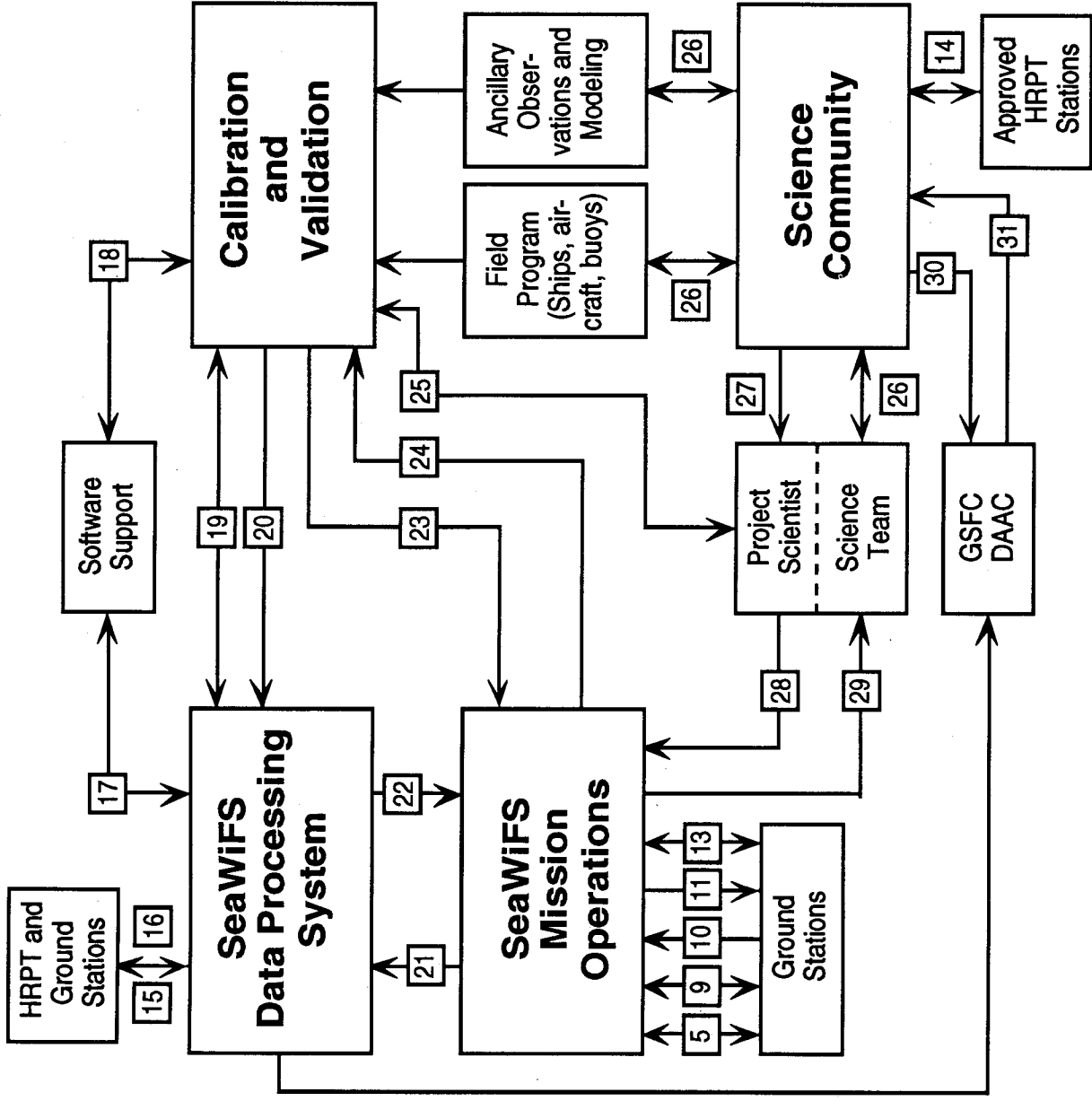

Fig. 8. SeaWiFS Project schematic: ground and space elements.



- 17** Software updates.
- 18** Calibration updates, product quality and control feedback, and revised algorithms.
- 19** Calibration, HRPT, GAC, LAC and ancillary data, plus telemetry files.
- 20** Validated ancillary data, sensor trend reports and data status reports.
- 21** Schedules and coordination.
- 22** Telemetry and data status.
- 23** Reports of detected anomalies, LAC coverage requests, and calibration requests and updates.
- 24** Coverage opportunities.
- 25** Recommended mission changes and revised LAC coverage requests.
- 26** Coordination with the scientific community.
- 27** Requests for LAC coverage.
- 28** Mission requirements.
- 29** Mission status.
- 30** Queries and data requests.
- 31** Catalog and data distribution.

Fig. 9. SeaWiFS Project schematic: system and processing elements.

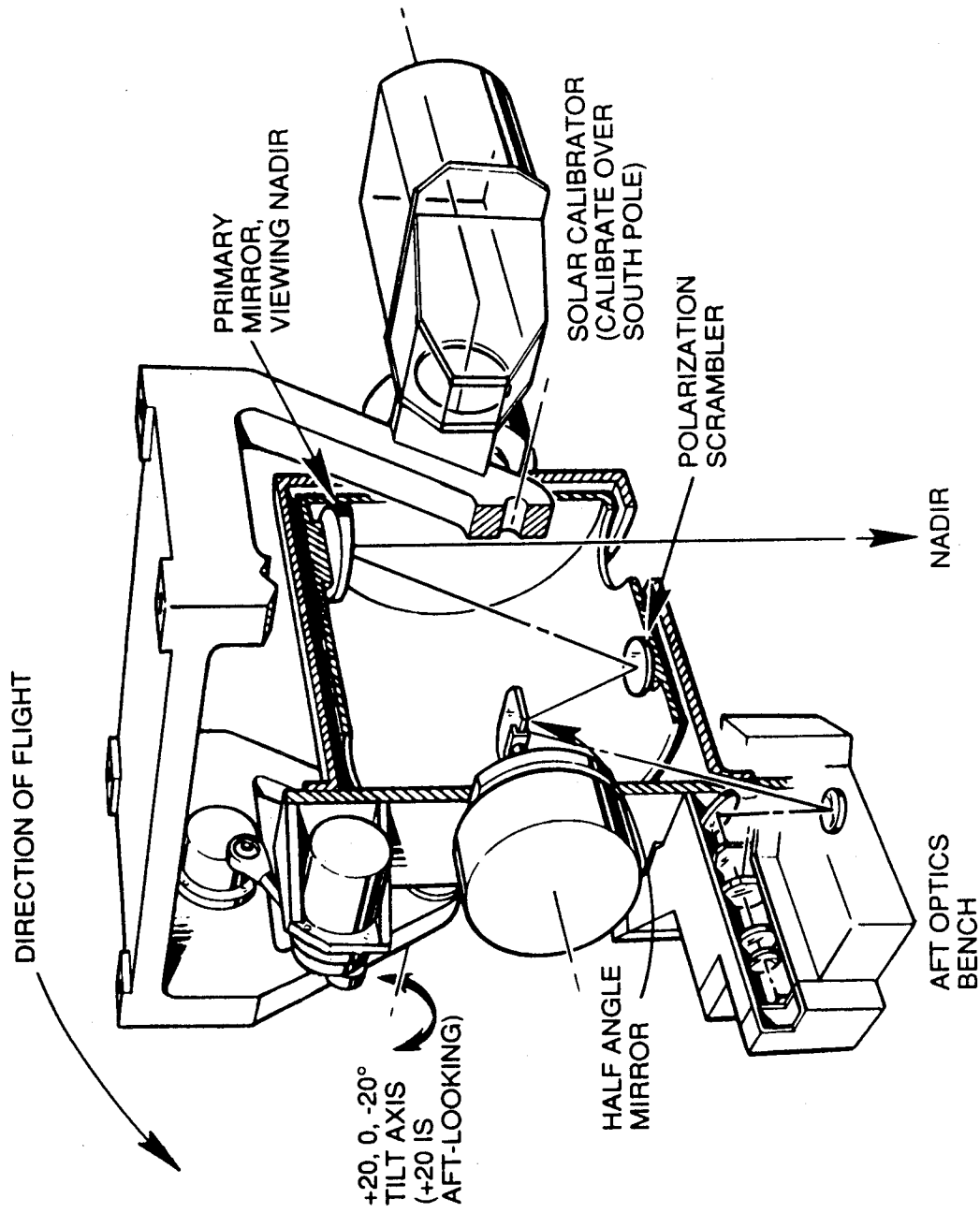

Fig. 7. Schematic of the SeaWiFS scanner assembly which scans from west to east.

the GSFC DAAC for archive and distribution.

Calibration and Validation: This element oversees the quality of the ancillary data and SeaWiFS products, and generates analysis reports. It is responsible for establishing and updating calibration procedures for the SeaWiFS data, using correlative data for the validation of the higher level products, performing trend and anomaly analysis, and collecting ancillary data sets such as winds, atmospheric pressure, ozone, etc., from various sources. A detailed description of this element is given in Section 7.

Software Support: This element is responsible for programming assistance and database support, software updates, software integration and testing, and software configuration management.

Mission Operations: This element serves as the single point-of-contact for OSC and the GSFC HRPT station to communicate, coordinate scheduling, and report any problems. It also monitors telemetry,

performs scheduling activities for scientific aspects of mission operations, and provides navigation information and orbital elements required for processing and data collection. Current calibration tables and navigational information will be provided to OSC to be uplinked to SeaStar. These will be included in the HRPT downlink.

6.1 Ground Systems and Support

The SeaStar Spacecraft Operations Center (SOC) will be an OSC facility and will be located in the Washington, DC area. The SOC has a fully steerable five meter antenna, PC-based tracking computer, and redundant receiver and demodulators for both the 2.0 Mbps S-band GAC and LAC stored data transmission, and 665 kbps L-band direct broadcast HRPT LAC/telemetry data stream. A digital front end includes redundant bit and frame synchronizers, command encoders, timing subsystems, and a simulator for system data flow testing. Redundant telem-

etry/command consoles provide telemetry processing and command capability. The SOC also contains commercial science data processing and product generation facilities.

Although OSC will operate the SOC, the SPO will define recording times, sensor tilt angle, recorded data transmission times, and calibration events, within limits of safe operation, and will forward these parameters to the SOC. The SOC will be manned during the noon pass, but will function automatically during the midnight pass.

The ground segment serves three functions: spacecraft control, data delivery to GSFC, and data delivery to commercial users. The first and third functions are the sole responsibility of OSC. The second function will be supported by the two ground receiving stations, one for the acquisition of recorded data and one for the acquisition of direct broadcast data. The ground station for the acquisition of the direct broadcast data will be at GSFC in Greenbelt, Maryland. This HRPT ground station will consist of a prime computer system with two backup systems. The Search and Rescue Satellite (SARSAT) Ground Station, located in Building 22 at GSFC, will serve as its backup. The primary antenna is an eight foot perforated parabolic program track antenna. It will be dedicated to the capture of SeaWiFS HRPT data. For a downlink frequency of 1702.5 MHz, the antenna gain is about 30 db and the beam angle is 5.14°. The backup antenna is located on the roof of Building 22 and will be available to SeaWiFS on a time available basis. The orbital Acquisition of Signal/Loss of Signal (AOS/LOS) Tables for the Greenbelt stations for nominal conditions have been determined.

The ground station for the acquisition of the recorded data is at WFF. The primary antenna is a nine meter autotrack that is currently being used as a backup for the International Ultraviolet Explorer (IUE). The backup antenna is a 7.5 meter receive-only autotrack that is available on a non-interference basis with the Wallops Launch Range. The orbital AOS/LOS Tables for the WFF Ground Station for nominal conditions have also been calculated. The recorded data will be transmitted to the SDPS facility in Building 28 at GSFC where the data will be stored in a computer-addressable file on disk. The time required to transfer 1.0 Gbits of data from WFF to the VAX at 792 kbps is about 22 minutes. The dumps will normally occur during normal working hours at a mutually agreeable schedule. The raw data will be stored at WFF on magnetic tape for 14 days.

6.2 Data Processing System

SeaWiFS will produce two types of science data. LAC, with a nominal ground resolution of 1.13 km, will be directly broadcast and selectively recorded, while GAC, subsampled every fourth line and every fourth pixel, with a nominal ground resolution of 4.5 km, will be recorded on board. Direct broadcast LAC will be routinely received at GSFC for the U.S. East Coast, and other real time

LAC will be received at various HRPT stations around the world. Recorded LAC data for preselected areas and all GAC data will be received at the WFF and forwarded to the SDPS at GSFC.

The document, *SeaWiFS Science Data and Information System Architecture Report* (1991), describes the basic functions, interfaces, and requirements of the SDPS in detail. Briefly, SDPS will receive data, manage data, i.e., catalog and archive; generate standard products; generate calibration products; ensure data distribution; schedule and monitor the science mission; calibrate and validate data products; support software updates; and provide systems support (see Fig. 9). These functions are performed by three distinct elements. The SDPS receives and manages science and ancillary data and generates standard products; the Mission Operations element performs planning, scheduling, and health and safety monitoring; and the Calibration and Validation element develops procedures that are then implemented by the SDPS. SDPS personnel will provide software and systems support. The Data Capture Facility (DCF) acquires data and transfers it to the SDPS.

Key external interfaces with the SDPS are fully described in the aforementioned report. These external interfaces are the Wallops Ground Station, OSC mission management, GSFC HRPT station, non-SeaWiFS data sources, SeaWiFS Science Team, Science Research Community, the GSFC V0 DAAC, and the NASA Sponsored HRPT Stations.

The SPO will produce a limited set of standard data products for archiving and distribution:

Level-1 GAC and LAC (~4.5 km and ~1.1 km at nadir, respectively) resolutions.

Level-2 Processed data at GAC and LAC resolutions:

- pigment and chlorophyll *a* concentration,
- diffuse attenuation coefficient at 490 nm,
- normalized water-leaving radiances (5),
- aerosol radiances (3), and
- an error field.

Level-3 Global gridded products (at approximately 9 km resolution) of the above listed parameters and statistics at time averages ranging from daily to annual periods.

To accommodate expected schedules in receiving required ancillary data, operational scenarios for three types of processing to level-3 products have been developed. These are: Performance Assessment processing within 24 hours, Refined Processing within 30 days, and subsequent annual Global Reprocessing (if needed). A three-tiered archival strategy was developed that conforms to these scenarios, with 30 day, 180 day, and permanent retention periods, respectively.

The SDPS will ingest approximately 381 Mbytes per day of science data and generate products totaling up to 3 Gbytes per day. The SDPS is sized to perform valida-

tion processing and global reprocessing at ten times the speed of routine processing. The preliminary total central processing unit (CPU) requirements for the processing and reprocessing are estimated to be equivalent to a 250 million instructions per second (mips) scalable processor. The permanent archive is sized to 6 Tbytes over the lifetime of the mission, which assumes archiving only data received at GSFC and WFF. The temporary archive is estimated to be 300 Gbytes. Ongoing prototyping activities will refine these estimates. Central archiving of HRPT level-1a data will require approximately 100 Mbytes per station per day. A high speed network, such as the Fiber Data Distribution Interface (FDDI), is required to support the projected input/output (I/O) and network workloads.

The storage media and processor options have been examined. Based on trade-off studies, disk arrays are recommended for data staging, a magneto-optical drive jukebox is recommended for the 30 day temporary archive, an 8 mm library for the 180 day temporary archive, and a write once read many (WORM) times optical library for the permanent archive.

Product generation CPU platforms have been surveyed to select the most viable candidates. The primary evaluation criteria are scalability, high performance, and open portability. Given their multiprocessing capability, high-end workstations from Silicon Graphics were selected for the product generation platform.

Two potential architecture implementations have been assessed: a hybrid VMS and UNIX architecture based on the current GSFC Ocean Color Processing System, and an all UNIX architecture. The adoption of the hybrid architecture and development of an implementation plan to move to an all UNIX environment is the baseline plan. The justifications for this conclusion follow. In the long run, the all UNIX implementation will achieve an open system architecture with a potentially lower lifecycle cost and greater flexibility and portability. However, the current process control and data management software, which is VMS dependent, is a proven and operational system. The use of these proven components will reduce schedule and development risks.

6.3 Distribution System

The SeaWiFS Project has the responsibility to ensure the distribution of SeaWiFS data to all NASA approved SeaWiFS data users. Some of the Science Team members, or NASA sponsored HRPT stations, may require near real-time SeaWiFS data. The Project will support the near real-time distribution to this group of users. SeaWiFS data will be permanently archived at the GSFC DAAC. Users will get the SeaWiFS data through the GSFC V0 DAAC, at the nominal cost of duplication.

The data distribution system will be in place prior to launch. The distribution system will utilize the experience gained during the development and operation of the

current CZCS data distribution system. Authorized users may also request HRPT LAC data archived at NASA sponsored HRPT stations. Some organizations may request distribution of certain types of products as they are produced. This routine data distribution will first be approved by the SPO, and implemented as a routine daily operation.

Access to the archive system will be provided to all users who will initiate their data search through a user interface, such as a terminal. Users will be asked to give their name, address, phone number, institution, etc. All users can access the Metadata or data catalog, but only authorized users may access the Browse Archive. As the user examines the Metadata or Browse Archive, parameter attributes are defined. The user then makes a request to the DAAC, which verifies the authenticity and authorization of the request. After the request has been approved, data in the archive will be retrieved, copied onto appropriate media, and sent to the user. The user's account will be updated to include the data distributed for this request. The cost of distribution has not been defined.

If the requested data reside in one of the NASA sponsored HRPT archive stations, a request will be sent to the archival system of the HRPT station. The HRPT station will acknowledge receipt of the request, search for the data, and then retrieve, duplicate, and send the requested data to the user. In this scenario, the user makes a request for HRPT LAC data directly to the collecting HRPT station. The HRPT station must verify the user's authorization before processing the request.

It is anticipated there will be on the order of 200 users per year of SeaWiFS data. (There are about 100 users for the current CZCS data.) Out of the 200 users, there will be about 20 SeaWiFS Science Team members and 12 NASA sponsored HRPT stations that will have the capability to use data in near real-time, and an estimated 75 research HRPT stations that will use data after the embargo period. Of the Team Members and HRPT stations, about 20 users are estimated to require all of the SeaWiFS data.

Depending on the frequency of data requests for the level of data, the following two types of data granules, or scenes, are envisioned for level-1 and level-2 data: 1) 10 minutes of data in spacecraft coordinates along-track and cross-track for the whole swath, and 2) fixed area, 1500 x 1500 km for fixed tilt. Level-3 data will be available for fixed regions for daily, eight-day, monthly, and annual time periods.

6.4 Mission Operations

The primary objectives of the GSFC Mission Operations element are, in order of priority:

- Acquire a complete set of scientifically useful GAC data on board the spacecraft on full global scales,
- Acquire all GAC data on the ground at WFF,

- Acquire LAC data over all calibration targets,
- Develop navigation algorithms to provide pointing knowledge to 1 pixel accuracy, root mean squared ($\text{rms}, 1\sigma$) on a global scale, and
- Provide support for HRPT stations and the user community.

These objectives define the primary functions of Mission Operations:

- a) Provide sensor operations schedule; single point-of-contact on spacecraft operations with OSC's SeaStar Operations Ground Subsystem (SOGS);
- b) Provide elements and vectors to WFF for stored data acquisition;
- c) Navigate observations;
- d) Serve as single point-of-contact with the HRPT station and the user community on pointing vectors and support; and
- e) Assist in calibration by providing spacecraft-sun-lunar geometrical information.

Central to the Mission Operations primary functions is the operation of an orbital prediction model. This model provides the information required to generate schedules of sensor operations, ensure timely transmission of stored data to the ground, and allow accurate pointing information for HRPT stations, as well as assist in navigation and calibration.

Fulfillment of the primary functions of Mission Operations requires the establishment and maintenance of seven interfaces:

- 1) OSC SOGS,
- 2) WFF,
- 3) Project Scientist,
- 4) Calibration and Validation Team (CVT),
- 5) SDPS,
- 6) DCF, and
- 7) NASA approved research HRPT stations.

The OSC SOGS interface is the element for the passing of schedules. The SOGS performs the actual commanding of the sensor and spacecraft based on the GSFC provided schedules, as well as for OSC determined commercial purposes. Also, the SOGS will perform orbit maintenance maneuvers to keep the spacecraft in an optimum orbit for scientific observations 705 km, noon equator crossing time, and perform attitude control necessary to meet the one pixel navigation knowledge requirement. The SOGS will assess the power and thermal environment to ensure the five-year mission lifetime.

WFF is the primary downlink station for stored data acquisition. Information of the spacecraft positions and times for downlink are provided by GSFC Mission Operations.

The Project Scientist provides approval for all scientific operations and oversight of the mission to ensure that the scientific objectives are met. The Project Scientist will be kept informed on mission status and scheduling conflicts on a regular basis.

The CVT determines the locations, times, priorities, and frequencies of coverage of calibration targets and communicates this information to Mission Operations. Mission Operations then schedules recorded LAC coverage to meet these observational requirements within the constraints of power, thermal, and data recorder budgets. Mission Operations will also assist the CVT Manager by determining spacecraft-sun-lunar geometries required for proper utilization of the calibration data.

The SDPS is the repository of SeaWiFS data. Telemetry necessary for navigation and for keeping the orbital predictions models current, will be supplied to Mission Operations by the SDPS. Mission Operations will supply copies of the sensor schedules to the SDPS to assist in data processing and to monitor the execution of commands.

The DCF operates an HRPT station at GSFC, Building 26, to receive real-time LAC data for health and safety monitoring. The DCF also serves as an intermediary in the pathway of stored data from WFF to the SDPS, re-formatting data from NASA communication (NASCOM) blocks, which is the transmission medium. Mission Operations will assist these efforts by providing updated orbital elements to the DCF for antenna pointing by making downlink schedules available, and by keeping DCF informed of mission status. The DCF also provides support to NASA approved HRPT stations. Requests for support are routed through Mission Operations.

Finally, Mission Operations serves as a single point-of-contact for the user community and NASA approved HRPT stations. Mission Operations will operate and maintain an electronic bulletin board containing mission status; orbital elements; a LAC requestor by which authorized users may request recorded LAC time; an HRPT station locator through which users may find the locations, names, and addresses of HRPT stations containing data of interest; and other project information, such as the status of data processing. Mission Operations will maintain and distribute the Authorized User List to HRPT stations and the Data Processing element.

6.5 Sensor Operations Schedules

The primary responsibility of the GSFC Mission Operations element is to provide OSC with schedules of command sequences to maximize the coverage and scientific usefulness of SeaWiFS data and to ensure data acquisition. The commands under the responsibility of Mission Operations are:

- 1) Stored data downlink times at WFF;
- 2) Gain changes;

- 3) GAC record, tilt change, calibration, and LAC record times;
- 4) Broadcast times for research HRPT stations;
- 5) Updated calibration tables; and
- 6) TDI sequence.

The passing of downlink times at WFF to OSC and WFF ensures the timely transmission and acquisition of stored data. This function is second in importance because the mission is a failure unless data are received on the ground. SeaWiFS will pass over WFF near noon and near midnight each day. Mission Operations will provide the overpass schedules to WFF and to OSC so OSC can command data transmission and WFF can receive it.

The tilt capability of SeaWiFS provides sun glint avoidance. Improper tilts will result in data of poor or useless scientific quality. SeaWiFS can tilt $+20^\circ$ (aft of the velocity vector; toward the South Pole), -20° (forward along the velocity vector; toward the North Pole) or 0° (nadir pointing) in three steps. Provision of tilt times by Mission Operations to OSC will enable minimization of sun glint contamination.

Calibration times are necessary to provide quantitative radiances of the highest scientific quality. There are three types of calibration activities proposed for SeaWiFS: lunar, solar, and *in situ*. Lunar calibration will occur when the moon is near phase (6°), and is accomplished by pitching the spacecraft toward the moon on the dark side of the orbit. Solar calibrations will occur as the spacecraft passes near the South Pole as needed, perhaps as much as every orbit. *In situ* calibration includes ship, moored buoy, and drifting buoy observations, and perhaps pre-determined calibration areas. Ship observations are sporadic events requiring frequent coordination with the CVT. However, some moorings may be in place for long periods of time and may require routine spacecraft observations. Calibration activities take secondary priority in data recording time to GAC observations. All calibration observations will be placed in the LAC recording area on the onboard computer.

Selection of gain enables maximum sensitivity of the sensor under conditions of changing signal magnitude. The proper gains must be chosen for calibration activities, i.e., solar and lunar calibration. Mission Operations will relay these gain change schedules to OSC.

LAC record times provide the high resolution data required for certain scientific activities, such as event monitoring. Any space left on the onboard data recorder after GAC and calibration recording, may be used for LAC recording. Assuming a nominal 40 minutes per day of GAC recording, there will be 17-19 minutes of data per day available for LAC recording and calibration. Requests for LAC data may come from the SeaWiFS Project Scientist, the SeaWiFS Science Team, or research users previously authorized by the SPO.

Slots are available in the telemetry data stream on

board the spacecraft for calibration tables, by agreement with OSC. The existence of these tables in the data stream enables users, especially those with HRPT stations, to calibrate SeaWiFS data using the most updated coefficients without requiring access to a different data source. Coefficients must be uplinked by the SOGS on a routine basis, and changes must be made as necessary to ensure timeliness. Mission Operations will submit calibration tables to the SOGS as part of the schedules. Maintenance of the tables and decisions to update rest with the CVT. Mission Operations will add the most recent orbital elements to the tables to enable HRPT stations to point antennas using data in the data stream.

TDI is a technique using multiple detector elements to improve SNR. The SeaWiFS sensor employs four detectors per band, providing four looks at each ground pixel. The four readings are integrated to reduce noise by about a factor of 2. Should an individual detector element lose sensitivity or become excessively noisy, the capability to eliminate it from the integration sequence and count another element twice, is under command control. Periodically, the various combinations of detectors in the TDI sequence will be exercised to determine their performance, and changes to the sequence will be implemented if necessary.

6.6 Sensor Monitoring

Both NASA/GSFC and OSC will monitor sensor performance, health, and safety. The Mission Operations element will be in a central position to perform monitoring of incoming telemetry. Any anomalies detected anywhere within the system must be rapidly communicated to all participants, and the Mission Operations element provides the primary interface with OSC for operational functions and will be central in the dissemination of such information. The monitoring will be performed by graphical presentation of key telemetry parameters for each orbit. Multiple displays will be used to monitor the telemetry quality and flag out-of-limit values. Also, subsystems information such as alarm determination, power condition, command and event mode, and configuration displays are provided.

Selected key parameters will be extracted from the telemetry data files and maintained in a dynamically configurable database to minimize database transaction processing and storage requirements. This database will be used to perform long-term trend analyses and generate selected and periodic performance assessment reports.

Orbit parameters are determined using GPS, yielding position and velocity to within 70 m and 1 m s^{-1} , respectively. Position information will be downlinked, along with telemetry, in the data stream. Thus the need for sophisticated satellite tracking is eliminated.

7. CALIBRATION/VALIDATION

GSFC has the responsibility to lead a product assurance, calibration, and validation program, and to deter-

mine the degree to which the commercially procured ocean color data fulfills the contractually stated NASA requirements. Background experience for this effort was obtained from the CZCS sensor which had limited objectives, namely, a limit of 2 hours of coverage per day, a one-year demonstration lifetime, and a 10% level-2 data processing goal. Despite the limited design lifetime of the CZCS mission, data was collected from October 1978, until June 1986. In 1985, GSFC and the University of Miami undertook the task of processing all of the CZCS data. The global CZCS data processing was completed in March 1990. Much was learned from the CZCS experience in terms of calibration requirements, sensor design, algorithm design, and scientific applications. The SeaWiFS Project is designed to compensate for a number of shortcomings in the CZCS data set both in terms of the instrument, and in the calibration and validation areas.

The calibration and validation program has three main tasks: calibration of the SeaWiFS instrument, development and validation of the operational atmospheric correction algorithm, and development and validation of the derived product algorithms, such as chlorophyll *a* concentration. Some of this work will be done internally at GSFC while the remainder will be done externally at other institutions. NASA and the SPO are placing the highest priority on assuring the accuracy of derived water-leaving radiances globally, and over the entire mission. If these criteria are met, development of global and regional biogeochemical algorithms can proceed on many fronts. These activities are discussed in detail in, *The SeaWiFS Calibration and Validation Plan* (McClain et al. 1992). Figure 10 and Table 3 provide overview schematics of the SeaWiFS calibration and validation program structure and milestones, respectively.

Included in the validation program is the development of atmospheric correction and bio-optical algorithms required to produce the derived products. The atmospheric correction algorithms for processing SeaWiFS data are under development and include a number of improvements over the CZCS algorithms. Some field studies are needed, however, to collect specific data sets to implement these improvements. External activities are largely being pursued by the MODIS Oceans Team and by other investigators via contracts and grants issued by the SPO. Most internal activities incorporate close collaborations with these groups. The program also needs a field effort that includes bio-optical cruises. The few existing bio-optical data sets applicable to SeaWiFS are very limited in scope, and system algorithm initialization requires coincident space and ocean measurements.

The field studies mentioned above fall into the external activities category. Internal activities include the development of bio-optical databases and the intercomparison of various atmospheric correction and bio-optical algorithms. Investigators funded by NASA to assist with algorithm development will have access to these databases.

Although general access will not be available immediately, it is expected that these data will be provided to a suitable archive facility within two years for unlimited distribution.

Atmospheric correction algorithms use data from other sources, such as ozone concentrations and surface pressure fields, and the quality of these fields must be assessed before the data are incorporated into the processing. Finally, quality assessment and control functions for the final derived products will be performed prior to release of the data by comparison with historical and simultaneous field observations submitted to the SPO by various field programs and individual investigators.

The Internal activities related to calibration can further be divided into those associated with the onboard calibration and those connected with the vicarious calibration. The Instrument Scientist and the Calibration Manager bear primary responsibility for the former and the Algorithm and Validation Manager is responsible for the latter. The onboard calibration includes analysis and documentation of the initial prelaunch characterization and calibration data provided by Hughes/SBRC and the analysis of post-launch data from the solar diffuser plate and lunar imagery. The vicarious calibration involves the collection, analysis, and intercomparison of optical surface truth with the derived satellite water-leaving radiance fields.

Table 3 provides a list of required observations for the vicarious calibration, validation, algorithm development, and support science, which were approved by the SPSWG in August 1991. They are derived from the findings of a workshop that defined the requirements and protocols for *in situ* optical validation measurements (Mueller and Austin 1992). The SeaWiFS Project has adopted the recommendations of the JGOFS on protocols for biogeochemical validation measurements, such as chlorophyll *a*.

Also included in the validation program is the development of the atmospheric correction and bio-optical algorithms required to produce the derived products as defined by the Science Working Group. Presently, the atmospheric correction algorithms needed for processing SeaWiFS data have not been developed and a number of improvements over the CZCS-class algorithm are necessary. To implement these improvements, however, some field studies are required to collect specific data sets. Similarly, because the existing bio-optical data sets applicable to SeaWiFS are either very limited in scope or are non-existent, a field program must be implemented to support dedicated bio-optical cruises. These field studies fall in the External activities category.

All GSFC Internal operations are co-located with the SeaWiFS processing system and utilize certain common subsystems and databases. This is different from the CZCS processing scenario where calibration functions were undertaken at the University of Miami and the quality control of the derived products was conducted at what is now the Laboratory for Hydrospheric Processes' Oceans Computer Facility. The integrated SeaWiFS arrangement will

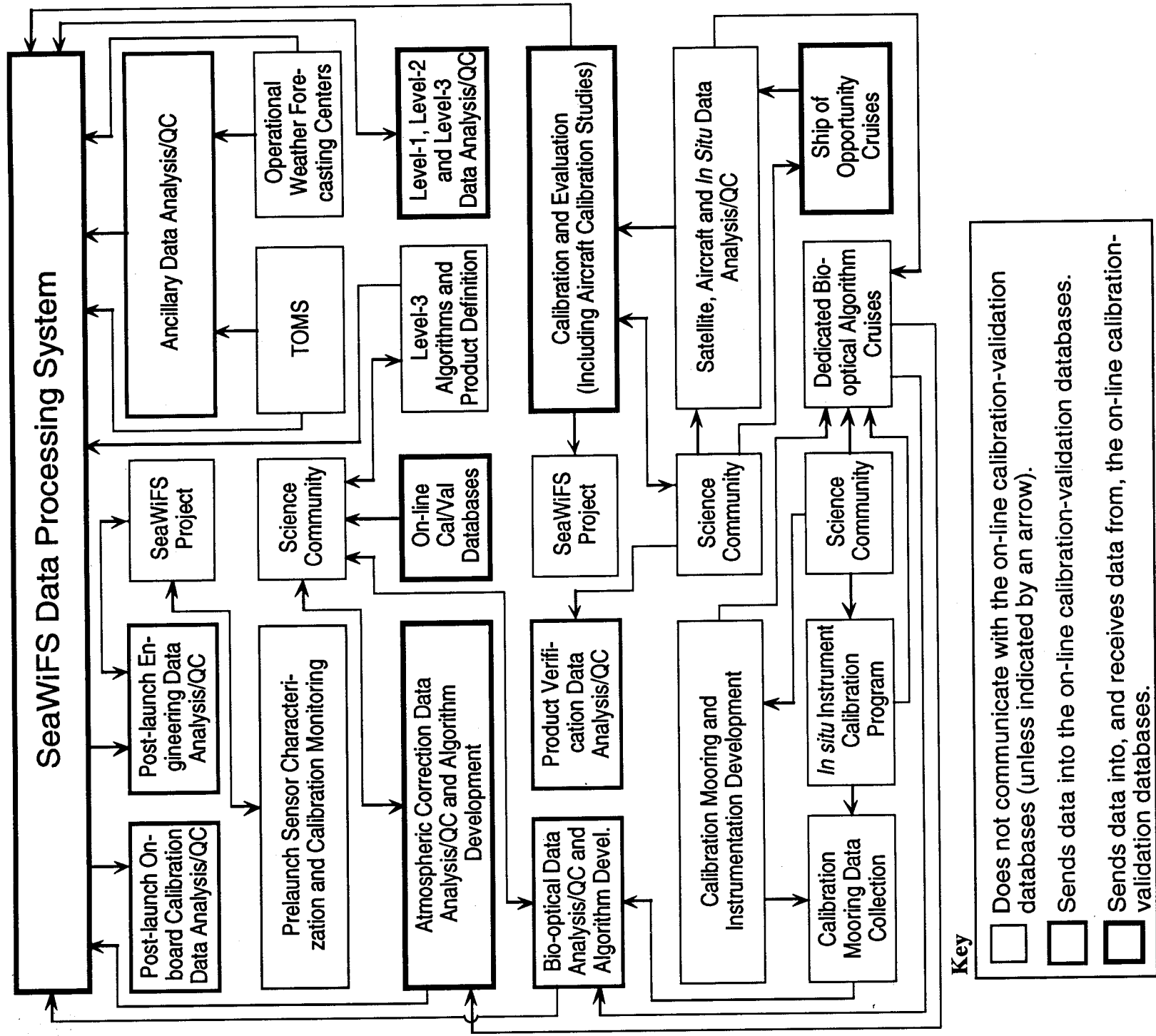

Fig. 10. SeaWiFS calibration and validation program structure.

Table 3. Required observations for initialization and system calibration for satellite product verification and radiative transfer (also ongoing calibration and atmospheric algorithm validation studies) and bio-optical algorithm development and validation (Mueller and Austin 1992).

	Product Verification	Radiative Transfer	Bio-optical Algorithms
<i>Primary Optical Measurements</i>			
Incident Spectral Irradiance, $E_d(0^-, \lambda)$	x	x	x
Downwelled Spectral Irradiance, $E_d(z, \lambda)$	x	x	x
Upwelled Spectral Radiance, $L_u(z, \lambda)$	x	x	x
Spectral Solar Atmospheric Transmission, $\tau_s(\lambda)$	x	x	x
Submerged Upwelled Radiance Distribution, $L(z, \theta, \phi)$	x	x	x
Spectral Sky Radiance Distribution	x	x	x
Upwelled Spectral Irradiance, $E_u(z, \lambda)$	x	x	x
<i>Calculated or Derived Variables</i>			
Water-leaving Radiance, $L_w(0^-, \lambda)$	x	x	x
Attenuation Coefficient Downwelled Irradiance, $K_E(z, \lambda)$	x	x	x
Attenuation Coefficient Upwelled Radiance, $K_L(z, \lambda)$	x	x	x
Spectral Reflectance, $R_L(z, \lambda)$	x	x	x
<i>Ambient Properties</i>			
Sea and Sky State Photographs	x	x	x
Wind Velocity	x	x	x
<i>In situ</i> Fluorescence Profiles	x	x	x
Aerosol Samples		x	x
Temperature and Salinity Profiles		x	x
Secchi Depth			x
<i>Primary Biogeochemical Measurements</i>			
Phytoplankton Pigments (HPLC Technique)		x	x
Phytoplankton Pigments (Fluorometric Technique)		x	x
Total Suspended Material (TSM) Concentration		x	x
Colored Dissolved Organic Material (CDOM)		x	x
<i>Inherent Optical Properties</i>			
Spectral Beam Attenuation Coefficient, $c(z, \lambda)$		x	x
Spectral Absorption Coefficient, $a(z, \lambda)$		x	x
Spectral Backscattering Coefficient, $b_b(z, \lambda)$		x	x
Spectral Volume Scattering Function, $\beta(z, \lambda, \theta)$		x	x
Red Beam Attenuation, $c(z, 660 \text{ nm})$		x	x
<i>Algorithm Specific Research Measurements</i>			
Airborne Fluorescence and Radiances		x	x
Coccolith Concentration		x	x
Detritus Absorption Coefficient		x	x
Humic and Fulvic Acids			x
Inorganic Suspended Material			x
Organic Suspended Material			x
Particle Absorption Coefficient		x	x
Particle Fluorescence			x
Particle Size Spectra		x	x
Particulate Organic Carbon (POC)			x
Particulate Organic Nitrogen (PON)			x
Phycobilipigments Concentration			x
Phytoplankton Species Counts			x
Primary Productivity (^{14}C)			x
Total Dissolved Organic Carbon (DOC)			x

x = Needed for the indicated effort.

simplify communication between the calibration and validation group and the operations personnel. Also, it more readily accommodates the demands of near real-time data processing that was not a consideration in the CZCS processing. The processing system is designed to accommodate the calibration and validation computational and data storage requirements, so that these activities do not impede the operational data processing.

8. SEAWIFS PROJECT OFFICE

SPO personnel and their areas of responsibilities at GSFC are given in Table 4. The sensor calibration and validation effort requires close coordination between the Instrument Scientist, the Calibration Manager, the Algorithm and Validation Manager, and the Project Scientist. The composition of the SPO straddles organizational boundaries and reflects the fact that the Project is an Earth Sciences Directorate (Code 900) activity.

Table 4. Key personnel and elements of the SPO.

SPO Address	
NASA/Goddard Space Flight Center	
SeaWiFS Project, Code 970.2	
Greenbelt, Maryland 20771	
Telephone: (301) 286-9676	
FAX: (301) 286-3221	
E-mail: SeaWiFS.Project/Omnet	
SPO Personnel	
Dr. William Barnes	Instrument Scientist
Dr. Mary Cleave	Deputy Project Manager
Dr. Wayne Esaias	Project Scientist
Dr. Gene Feldman	Data System Manager
Dr. Watson Gregg	Mission Operations
Dr. Bruce Guenther	Calibration Manager
Dr. Stanford Hooker	Field Program Manager
Mr. Robert Kirk	Project Manager
Dr. Charles McClain	Algorithm and Validation Manager
Mr. Charles Vermillion	Ground System Manager

EOSDIS Earth Observing Satellite Data Information System

ESA European Space Agency

FDDI Fiber Data Distribution Interface

FWHM Full-Width Half-Maximum

GAC Global Area Coverage

GOFs Global Ocean Flux Study

GPS Global Positioning System

GSFC Goddard Space Flight Center

HPLC High Performance Liquid Chromatography

HRPT High Resolution Picture Transmission

I/O Instantaneous Field-of-View

I/O Input/Output

IUE International Ultraviolet Explorer

JGOFS Joint Global Ocean Flux Study

LAC Local Area Coverage

MERIS Medium Resolution Imaging Spectrometer

MIPS Millions of Instructions Per Second

MOBY Marine Optical Buoy

MODIS Moderate Resolution Imaging Spectrometer

MTF Modulation Transfer Function

NASA National Aeronautics and Space Administration

NASCOM NASA Communications

NASDA National Space Development Agency (Japanese)

NCDS National Climate Data System

NE δ L Noise Equivalent delta Radiance

NOAA National Oceanic and Atmospheric Administration

NSCAT NASA Scatterometer

OCTS Ocean Color Temperature Sensor (Japanese)

OSC Orbital Sciences Corporation

OSSA Office of Space Science and Applications

POC Particulate Organic Carbon

POLDER Polarization Detecting Environmental Radiometer (French)

PON Particulate Organic Nitrogen

RFP Request for Proposal

rms root mean squared

SARSAT Search and Rescue Satellite

SBRC Santa Barbara Research Center

SDPS SeaWiFS Data Processing System

SeaWiFS Sea-viewing Wide Field-of-view Sensor

SNR Signal-to-Noise Ratio

SOC Spacecraft Operations Center

SOGS SeaStar Operations Ground Subsystem

SPO SeaWiFS Project Office

SPOT *Satellite Pour l'Observation de la Terre* (French)

SPSWG SeaWiFS Prelaunch Science Working Group

SST Sea Surface Temperature

SWG Science Working Group

TDI Time-Delay and Integration

TDRSS Tracking and Data Relay Satellite System

TOMS Total Ozone Mapping Spectrometer

TOPEX Topography Experiment

TSM Total Suspended Material

WFF Wallops Flight Facility

WORM Write Once Read Many

GLOSSARY

ACS Attitude Control System
 ADEOS Advanced Earth Observation Satellite (Japanese)
 AOS/LOS Acquisition of Signal/Loss of Signal
 AVHRR Advanced Very High Resolution Radiometer
 CDOM Colored Dissolved Organic Material
 CPU Central Processing Unit
 CVT Calibration/Validation Team
 CZCS Coastal Zone Color Scanner
 DAAC Distributed Active Archive Center
 DC Direct Current
 DCF Data Capture Facility
 DOC Dissolved Organic Carbon
 EOS Earth Observing Satellite
 EOSAT Earth Observation Satellite Company

REFERENCES

- Abbott, M.R., and P.M. Zion, 1985: Satellite observations of phytoplankton variability during an upwelling event, *Cont. Shelf Res.*, **4**, 661-680.
- , and D.B. Chelton, 1991: Advances in passive remote sensing of the ocean, U.S. National Report to International Union of Geodesy and Geophysics 1987-1990, *Contributions in Oceanography*, Am. Geophys. Union, 571-589.
- Austin, R.W., and T.J. Petzold, 1981: The determination of diffuse attenuation coefficient of sea water using the Coastal Zone Color Scanner, *Oceanography from Space*, J. Gower, Ed., Plenum Press, New York, 239-256.
- Balch, W.M., R. Evans, J. Brown, G. Feldman, C. McClain, and W. Esaias, 1992: The remote sensing of ocean primary productivity—use of a new data compilation to test satellite algorithms, *J. Geophys. Res.*, **97**, 2,279-2,293.
- Barale, V., and R. Wittenburg-Fay, 1986: Variability of the ocean surface color field in central California near-coastal waters as observed in seasonal analysis of CZCS imagery, *J. Mar. Res.*, **44**, 291-316.
- , C.R. McClain, and P. Malanotte-Rizzoli, 1986: Space and time variability of the surface color field in the northern Adriatic Sea, *J. Geophys. Res.*, **91**, 12,957-12,974.
- Berger, W.H., 1989: *Productivity of the Ocean: Present and Past*, V.S. Smetacek and G. Wefer, Eds., John Wiley & Sons, New York, 471 pp.
- Brock, J.C., C.R. McClain, M.E. Luther, and W.W. Hay, 1991: The phytoplankton bloom in the northwest Arabian Sea during the southwest monsoon of 1979, *J. Geophys. Res.*, **96**, 20,623-20,642.
- , and —, 1992: Interannual variability in phytoplankton blooms observed in the northwestern Arabian Sea during the southwest monsoon, *J. Geophys. Res.*, **97**, 733-750.
- Campbell, J.W., and J.E. O'Reilly, 1988: Role of satellites in estimating primary productivity on the northwest Atlantic continental shelf, *Cont. Shelf Res.*, **8**, 179-204.
- Comiso, J.C., N.G. Maynard, W.O. Smith, Jr., and C.W. Sullivan, 1990: Satellite ocean color studies of Antarctic ice edges in summer and autumn, *J. Geophys. Res.*, **95**, 9,481-9,496.
- Denman, K.L., and M.R. Abbott, 1988: Time evolution of surface chlorophyll patterns from cross spectrum analysis of satellite color images, *J. Geophys. Res.*, **93**, 6,789-6,798.
- Deuser, W.G., F.E. Muller-Karger, and C. Hemleben, 1988: Temporal variations of particle fluxes in the deep subtropical and tropical North Atlantic: Eulerian versus Lagrangian effects, *J. Geophys. Res.*, **93**, 6,857-6,862.
- , R.H. Evans, O.B. Brown, W.E. Esaias, and G.C. Feldman, 1990: Surface-ocean color and deep-sea carbon flux: how close a connection?, *Deep-Sea Res.*, **37**, 1,331-1,343.
- Eppley, R.W., 1984: Relations between primary productivity and ocean chlorophyll determined by satellites, in *Global Ocean Flux Study: Proceedings of a Workshop*, National Academy Press, Washington, DC, 85-102.
- Esaias, W., G. Feldman, C.R. McClain, and J. Elrod, 1986: Satellite observations of oceanic primary productivity, *EOS*, **67**, 835-837.
- Feldman, G., D. Clark, and D. Halpern, 1984: Satellite color observations of the phytoplankton distribution in the eastern equatorial Pacific during the 1982-1983 El Niño, *Science*, **226**, 1,069-1,071.
- , 1986: Variability of the productive habitat in the eastern equatorial Pacific, *EOS*, **67**, 106-108.
- , N. Kuring, C. Ng, W. Esaias, C. McClain, J. Elrod, N. Maynard, D. Endres, R. Evans, J. Brown, S. Walsh, M. Carle, and G. Podesta, 1989: Ocean Color: Availability of the global data set, *EOS*, **70**, 634.
- General Sciences Corp., 1991: SeaWiFS science data and information system architecture report, *GSC-TR-21-91-006*, General Sciences Corp., Laurel, MD, 133 pp.
- Gordon, H.R., D.K. Clark, J.W. Brown, O.B. Brown, and R.H. Evans, 1982: Satellite measurements of phytoplankton pigment concentration in the surface waters of a warm core Gulf Stream ring, *J. Mar. Res.*, **40**, 491-502.
- , —, —, —, —, —, and W.W. Broenkow, 1983: Phytoplankton pigment concentrations in the Middle Atlantic Bight: Comparison of ship determinations and CZCS estimates, *Appl. Opt.*, **22**, 20-36.
- Haury, L.R., J.J. Simpson, J. Pelaez, C. Koblinsky, and D. Wiesenbahn, 1986: Biological consequences of a recurrent eddy off Point Conception, California, *J. Geophys. Res.*, **91**, 12,937-12,956.
- Ishizaka, J., 1990a: Coupling of Coastal Zone Color Scanner data to physical-biological model of the southeastern U.S. continental shelf ecosystem, 1. CZCS data description and Lagrangian particle tracing experiments, *J. Geophys. Res.*, **95**, 10,167-10,181.
- , 1990b: Coupling of Coastal Zone Color Scanner data to physical-biological model of the southeastern U.S. continental shelf ecosystem, 2. an Eulerian model, *J. Geophys. Res.*, **95**, 10,183-10,199.
- , 1990c: Coupling of Coastal Zone Color Scanner data to physical-biological model of the southeastern U.S. continental shelf ecosystem, 3. nutrient and phytoplankton fluxes and CZCS data assimilation, *J. Geophys. Res.*, **95**, 10,201-10,212.
- Joint EOSAT-NASA SeaWiFS Working Group, 1987: System concept for wide-field-of-view observations of ocean phenomena from space, *Report of the Joint EOSAT/NASA SeaWiFS Working Group*, Earth Observation Satellite Co., Lanham, MD, 92 pp.
- Kuring, N., M.R. Lewis, T. Platt, and J.E. O'Reilly, 1990: Satellite-derived estimates of primary production on the northwest Atlantic continental shelf, *Cont. Shelf Res.*, **10**, 461-484.
- McClain, C.R., and L.P. Atkinson, 1985: A note on the Charles-ton Gyre, *J. Geophys. Res.*, **90**, 11,857-11,861.
- , S.-Y. Chao, L. Atkinson, J. Blanton, and F. de Castillejo, 1986: Wind-driven upwelling in the vicinity of Cape Finisterre, Spain, *J. Geophys. Res.*, **91**, 8,470-8,486.
- , J.A. Yoder, L.P. Atkinson, J.O. Blanton, T.N. Lee, J.J. Singer, and F. Muller-Karger, 1988: Variability of Surface Pigment Concentrations in the South Atlantic Bight, *J. Geophys. Res.*, **93**, 10,675-10,697.
- , J. Ishizaka, and E. Hofmann, 1990a: Estimation of phytoplankton pigment changes on the Southeastern U.S. continental shelf from a sequence of CZCS images and a coupled physical-biological model, *J. Geophys. Res.*, **95**, 20,213-20,235.
- , W.E. Esaias, G.C. Feldman, J. Elrod, D. Endres, J. Firestone, M. Darzi, R. Evans, and J. Brown, 1990b: Physical and biological processes in the North Atlantic during the First Global GARP Experiment, *J. Geophys. Res.*, **95**, 18,027-18,048.

- , G. Feldman, and W. Esaias, 1992: Oceanic primary production, accepted for the Global Change Atlas, C. Parkinson, J. Foster, and R. Gurney, Eds., Cambridge University Press.
- , W. Esaias, W. Barnes, B. Guenther, D. Endres, S. Hooker, G. Mitchell, and B. Barnes, 1992: Calibration and validation plan for SeaWiFS, *NASA Tech. Memo. 104566, Vol. III*, S. Hooker and E. Firestone, Eds., (in press).
- Michaelsen, J., X. Zhang, and R.C. Smith, 1988: Variability of pigment biomass in the California Current system as determined by satellite imagery, 2. temporal variability, *J. Geophys. Res.*, **93**, 10,883–10,896.
- Mueller, J.L., and R.E. Lang, 1989: Bio-optical provinces of the northeast Pacific Ocean: a provisional analysis, *Limnol. Oceanogr.*, **34**, 1,572–1,586.
- , and R.W. Austin, 1992: Ocean optics protocols, *NASA Tech. Memo. 104566, Vol. V*, S. Hooker and E. Firestone, Eds., (in press).
- Muller-Karger, F., C.R. McClain, and P. Richardson, 1988: The dispersal of the Amazon water, *Nature*, **333**, 56–59.
- , —, T.R. Fisher, W.E. Esaias, and R. Varela, 1989: Pigment distribution in the Caribbean Sea: Observations from space, *Prog. Oceanog.*, **23**, 23–64.
- , J.J. Walsh, R.H. Evans, and M.B. Meyers, 1991: On the seasonal phytoplankton concentration and sea surface temperature cycles of the Gulf of Mexico as determined by satellites, *J. Geophys. Res.*, **96**, 12,645–12,665.
- National Aeronautics and Space Administration, 1982: The marine resources experiment program (MAREX), *Report of the Ocean Color Science Working Group*, NASA/Goddard Space Flight Center, Greenbelt, MD, 107 pp.
- Platt, T., S. Sathyendranath, C.M. Caverhill, and M.R. Lewis, 1988: Ocean primary production and available light: further algorithms for remote sensing, *Deep-Sea Res.*, **35**, 855–879.
- , and —, 1988: Oceanic primary production: estimation by remote sensing at local and regional scales, *Science*, **241**, 1,613–1,620.
- Smith, R.C., X. Zhang, and J. Michaelsen, 1988: Variability of pigment biomass in the California Current system as determined by satellite imagery, 1. Spatial variability, *J. Geophys. Res.*, **93**, 10,863–10,882.
- Smith, S.L., W. Balch, K. Banse, W. Berelson, P. Brewer, O. Brown, K. Cochran, H. Livingston, M. Luther, C. McClain, D. Olson, L. Peterson, W. Peterson, W. Prell, L. Codispoti, A. Devol, H. Ducklow, R. Fine, G. Hitchcock, D. Lal, D. Repeta, E. Sherr, N. Surgi, J. Swallow, S. Wakeham, and K. Wishner, 1991: U.S. JGOFS: Arabian Sea Process Study, *U.S. JGOFS Planning Report No. 13*, Woods Hole Oceanographic Institution, Woods Hole, MA, 164 pp.
- Strub, P.T., C. James, A.C. Thomas, and M.R. Abbott, 1990: Seasonal and nonseasonal variability of satellite-derived surface pigment concentration in the California Current, *J. Geophys. Res.*, **95**, 11,501–11,530.
- Sullivan, C.W., C.R. McClain, J.C. Comiso, and W.O. Wood, 1988: Phytoplankton standing crops within an Antarctic ice edge assessed by satellite remote sensing, *J. Geophys. Res.*, **93**, 12,487–12,498.
- Wroblewski, J.S., J.L. Sarmiento, and G.R. Flierl, 1988: An ocean basin scale model of plankton dynamics in the North Atlantic 1. solutions for the climatological oceanographic conditions in May, *Global Biogeochem. Cycles*, **2**, 199–218.
- Yentsch, C.S., and D.A. Phinney, 1985: Rotary motion and convection as a means of regulating primary production in warm core rings, *J. Geophys. Res.*, **90**, 3,237–3,248.
- Yoder, J.A., C.R. McClain, J.O. Blanton, and L.-Y. Oey, 1987: Spatial scales in CZCS-chlorophyll imagery of the southeastern U.S. continental shelf, *Limnol. Oceanogr.*, **32**, 929–941.

REPORT DOCUMENTATION PAGE

Form Approved
OMB No. 0704-0188

Public reporting burden for this collection of information is estimated to average 1 hour per response, including the time for reviewing instructions, searching existing data sources, gathering and maintaining the data needed, and completing and reviewing the collection of information. Send comments regarding this burden estimate or any other aspect of this collection of information, including suggestions for reducing this burden, to Washington Headquarters Services, Directorate for Information Operations and Reports, 1215 Jefferson Davis Highway, Suite 1204, Arlington, VA 22202-4302, and to the Office of Management and Budget, Paperwork Reduction Project (0704-0188), Washington, DC 20503.

1. AGENCY USE ONLY (Leave blank) 2. REPORT DATE
July 1992

3. REPORT TYPE AND DATES COVERED
Technical Memorandum

4. TITLE AND SUBTITLE
SeaWiFS Technical Report Series
Volume 1, An Overview of SeaWiFS and Ocean Color

5. FUNDING NUMBERS
Code 970.2

6. AUTHOR(S)

Stanford B. Hooker, Wayne E. Esaias, Gene C. Feldman, Watson W. Gregg, and Charles R. McClain
Series Editors: Stanford B. Hooker and Elaine R. Firestone

7. PERFORMING ORGANIZATION NAME(S) AND ADDRESS(ES)

Laboratory for Hydrospheric Processes
NASA Goddard Space Flight Center
Greenbelt, Maryland 20771

8. PERFORMING ORGANIZATION
REPORT NUMBER

92B00089

9. SPONSORING/MONITORING AGENCY NAME(S) AND ADDRESS(ES)

National Aeronautics and Space Administration
Washington, D.C. 20546-0001

10. SPONSORING/MONITORING
AGENCY REPORT NUMBER

TM-104566, Vol. 1

11. SUPPLEMENTARY NOTES

Stanford B. Hooker, Wayne E. Esaias, Gene Feldman, Watson W. Gregg, and Charles R. McClain: NASA-GSFC, Greenbelt, Maryland. Elaine R. Firestone: General Sciences Corporation, Laurel, Maryland.

12a. DISTRIBUTION/AVAILABILITY STATEMENT

Unclassified - Unlimited
Subject Category 48

12b. DISTRIBUTION CODE

13. ABSTRACT (Maximum 200 words)

The purpose of this series of technical reports is to provide current documentation of the Sea-viewing Wide Field-of-view Sensor (SeaWiFS) Project activities, instrument performance, algorithms, and operations. This documentation is necessary to ensure that critical information related to the quality and calibration of the satellite data is available to the scientific community. SeaWiFS will bring to the ocean community a welcomed and improved renewal of the ocean color remote sensing capability lost when the Nimbus-7 Coastal Zone Color Scanner (CZCS) ceased operating in 1986. The goal of SeaWiFS, scheduled to be launched in August 1993, is to examine oceanic factors that affect global change. Because of the role of phytoplankton in the global carbon cycle, data obtained from SeaWiFS will be used to assess the ocean's role in this cycle, as well as other biogeochemical cycles. SeaWiFS data will be used to help elucidate the magnitude and variability of the annual cycle of primary production by marine phytoplankton and to determine the distribution and timing of spring blooms. The observations will help to visualize the dynamics of ocean and coastal currents, the physics of mixing, and the relationships between ocean physics and large-scale patterns of productivity. The data will help fill the gap in ocean biological observations between those of the CZCS and the upcoming Moderate Resolution Imaging Spectrometer (MODIS) on the Earth Observing System-A (EOS-A) satellite.

14. SUBJECT TERMS

Oceanography, SeaWiFS, Ocean Color, CZCS, Coastal Zone Color Scanner, Sensor, Bio-Optics, Biogeochemical, SeaStar, Data Processing, Calibration/Validation

15. NUMBER OF PAGES

25

16. PRICE CODE

17. SECURITY CLASSIFICATION
OF REPORT
Unclassified

18. SECURITY CLASSIFICATION
OF THIS PAGE
Unclassified

19. SECURITY CLASSIFICATION
OF ABSTRACT
Unclassified

20. LIMITATION OF AB-
STRACT
Unlimited