

C-6014

**NASA  
Reference  
Publication  
1280**

July 1992

**Three-Dimensional Laser  
Window Formation**

Vincent G. Verhoff



**NASA**  
**Reference**  
**Publication**  
**1280**

1992

**Three-Dimensional Laser  
Window Formation**

Vincent G. Verhoff  
*Lewis Research Center*  
*Cleveland, Ohio*

**NASA**

National Aeronautics and  
Space Administration

Office of Management

Scientific and Technical  
Information Program

## Summary

The NASA Lewis Research Center has developed and implemented a unique process for forming flawless three-dimensional laser windows. These windows represent a major part of specialized, nonintrusive laser data acquisition systems used in a variety of compressor and turbine research test facilities.

This report discusses in detail the aspects of three-dimensional laser window formation. It focuses on the unique methodology and the peculiarities associated with the formation of these windows. Included in this discussion are the design criteria, bonding mediums, and evaluation testing for three-dimensional laser windows.

## Introduction

An increased interest in fundamental research in turbines and compressors has created a need for nonintrusive optical flow measurement systems. The state-of-the-art systems used in obtaining detailed velocity data are called nonintrusive laser data acquisition systems. These systems seed the airflow with small particles that flow through a fringe pattern created by intersecting laser beams. Data are obtained by measuring the pulsating light reflected as the seed particles pass through the fringe pattern.

Optically clear laser windows are used for the laser beams and reflected light to pass through. Normally the laser window glass used in wind tunnels is approximately 1.0-in.-thick flat quartz. For turbine and compressor testing facilities, however, the windows are approximately 0.100 in. thick and have compound curvatures. The difference between the two windows is shown in figure 1.

Two types of errors can be introduced to the system by the laser window: spatial error of the measurement volume and reduced signal amplitude. Spatial error of the measurement volume is caused when the laser beams pass through the window at incident angles. The actual focal point is then skewed from the desired focal point, resulting in an error (ref. 1), as depicted in figure 2. Errors associated with reduced signal amplitude are caused by reflection of the laser beam as it passes through the window. Window size, curvature, thickness, surface quality, and contour tolerance are the major factors that control the magnitude of error.

Since laser windows are molded to the flow surface profile of the turbine and compressor casings, their size and curvature

cannot be altered. Window thickness, on the other hand, can vary. Thinner windows are desirable because they minimize error, but the glass must maintain high strength with reduced thickness. In addition, these thinner curved windows must be able to withstand high pressure and temperature differentials while preserving surface quality. This report will address these areas of concern and describe three-dimensional laser window formation and the process which maximizes the surface quality and contour accuracy. For this report, three-dimensional laser windows will be referred to as laser windows.

## Background

Laser systems are commonly used at NASA Lewis Research Center. Most of these systems are located in the engine component test facilities, such as the large, low-speed, centrifugal compressor facility, the supersonic throughflow fan facility, and the single-stage axial compressor facility. The window locations for these research facilities are shown in figure 3.

Overall safety is of primary concern. To uphold safety practices, the laser windows are hydrostatically pressure tested to 1.5 times the maximum operating pressures of the facilities. Operating pressures for various facilities range from 1.3 psia to 72 psia. Laser windows are also thermally qualified at facility temperatures and pressures if thermal differentials are significant. The laser windows are tested on both concave and convex surfaces to uphold the safety requirements.

## Glass Selection

Several types of glass have been used for laser window formation at Lewis Research Center. Sodium-lime, borosilicate, and sodium-alumino-silicate glass are among these types. On the basis of the Corning glass code 0317 (ref. 2), sodium-alumino-silicate glass has been determined to be the preferred glass for laser windows. This glass is recommended because of its ultra-high strength through chemical strengthening, which is unavailable with other glass types. This increased strength from chemical strengthening allows the use of thinner laser windows, which reduce spatial error and produce higher quality laser data. Sodium-lime glass is limited in the chemical



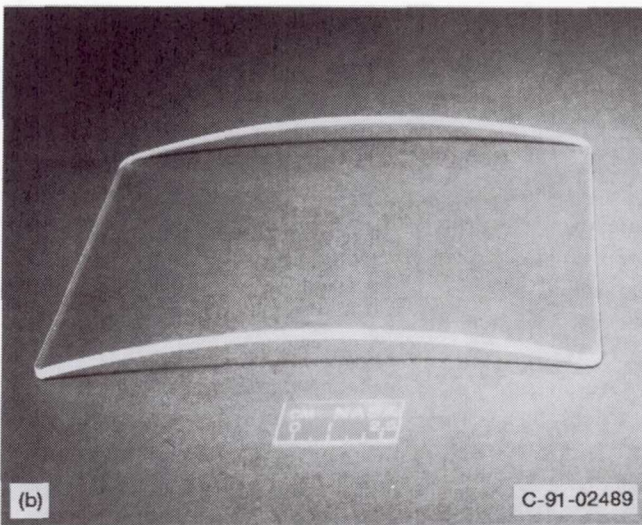
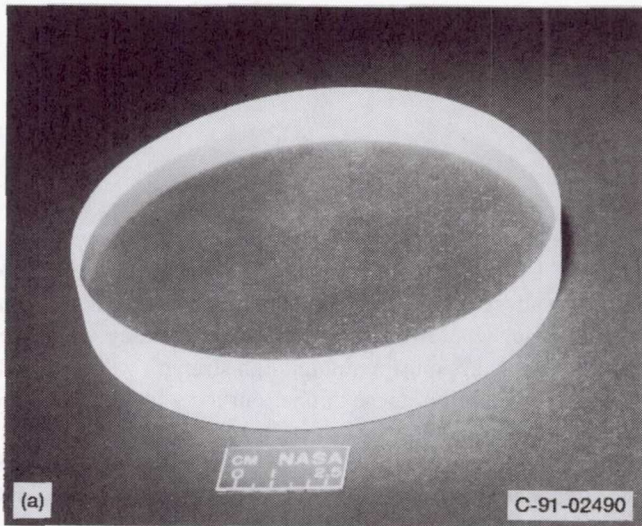

(a) Wind tunnel window.  
 (b) Turbine/compressor window.  
 Figure 1.—Typical laser windows.

strengthening process, which has not proven cost effective. Borosilicate glass is limited in strength which cannot be increased by the chemical strengthening process. Thermally tempered glass is also inadequate for laser systems because of regional glass annealing associated with the concentrated laser beams.

In addition, failure of a chemically strengthened sodium-alumino-silicate laser window will cause the window to shatter in tiny particles, only millimeters in cross-sectional area. This characteristic is advantageous since the smaller particles contain less energy and are less likely to damage blades or rotors. The particles from other failed glass windows are relatively large in cross-sectional area.

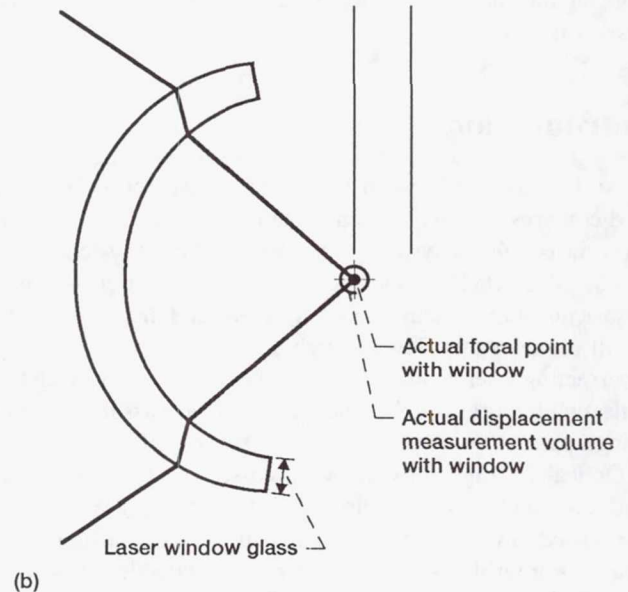
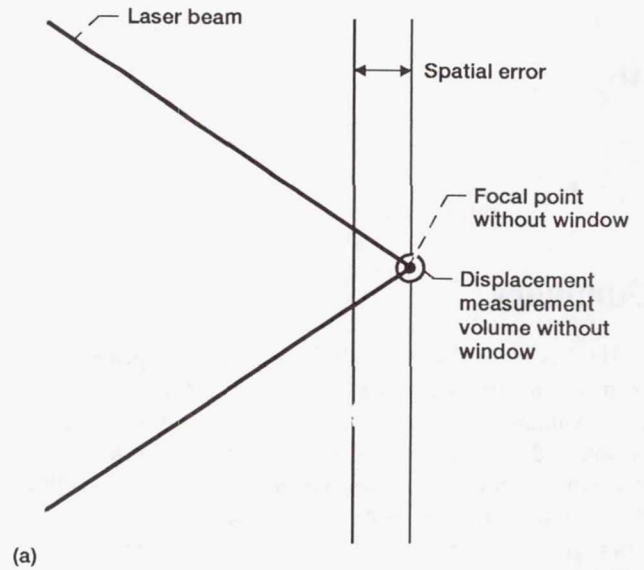

(a) Focal distance without window.  
 (b) Focal distance with window.  
 Figure 2.—Spatial error associated with laser windows.

## Mold Design

The mold material that offers the best results for forming laser windows is graphite; however, other machinable, high-temperature materials may be used. Machinable ceramic molds are expensive because of the cost of raw material, but they produce the best accuracies. Metal molds are undesirable because the glass adheres to the molds during the slumping operation.



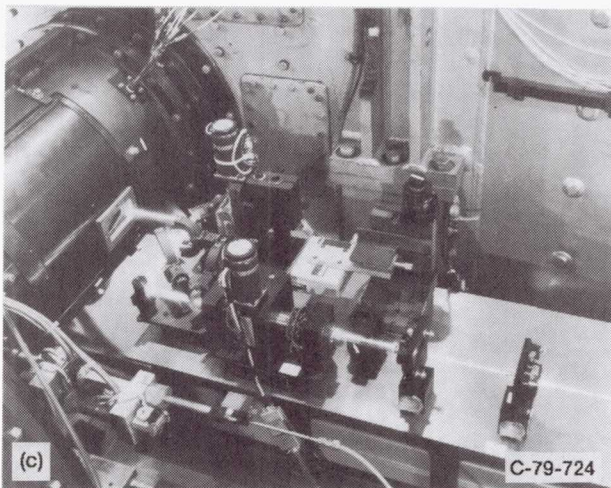
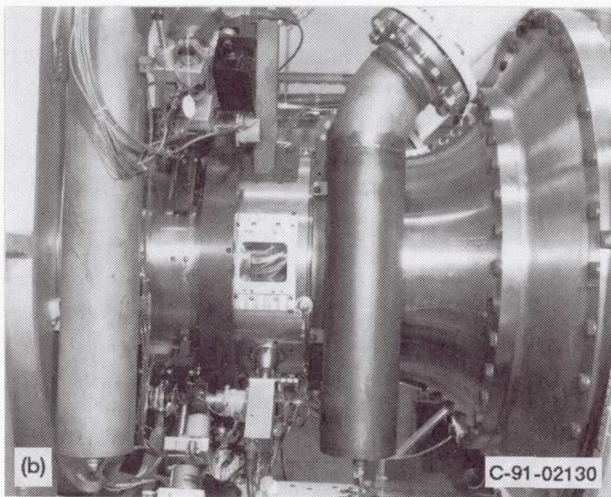
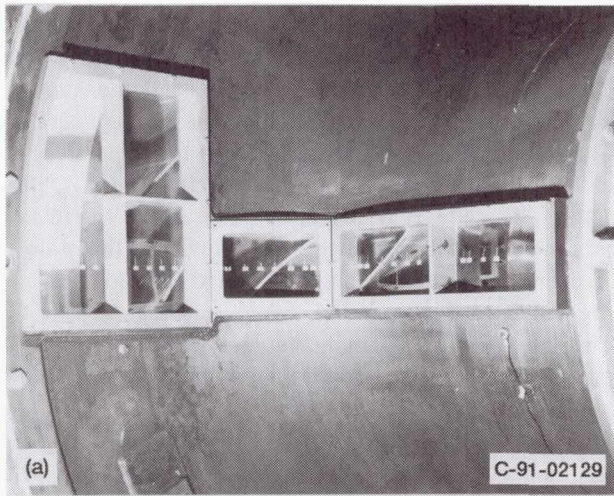

(a) Large, low-speed, centrifugal compressor facility.  
 (b) Supersonic throughflow fan facility.  
 (c) Single-stage axial compressor facility.

Figure 3.—Three-dimensional laser window facilities.

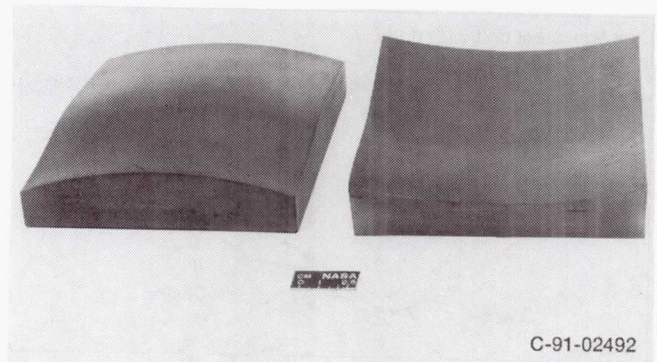

Figure 4.—Laser window male and female mold.

Graphite quality is an important issue. Low-quality graphite will outgas during the slumping operation, resulting in surface imperfections in the laser window glass. Normally, graphite with  $8\ \mu\text{m}$  or smaller particle size is recommended.

The graphite molds for laser window formation consist of a male and female mold, as shown in figure 4. The male mold is machined to match the internal flow path surfaces, whereas the female mold is machined to these coordinates plus the glass thickness. The overall dimensions of the molds are 1 in. greater than the actual size of the laser window glass. Both molds have threaded holes on the perimeter to fit graphite alignment bars. The alignment bars are secured to the molds using special stainless steel bolts with center holes drilled through them to allow the outgases of the graphite molds to escape.

Accurate machining and polishing of the molds used for laser window formation are essential. The graphite molds are machined and polished to a tolerance of 0.005 in. of the desired contour. After finish machining, these molds are polished to within a 16 to 20 Ra surface finish. The molds are close tolerance machined to maintain finished product (slumped glass) accuracy and quality.

All slumping components are machined out of graphite to ensure similar coefficients of thermal expansion. Orientation of the slumping component configuration is shown in figure 5.

## Glass Molding

The two types of furnaces typically used for laser window formation are inert gas and vacuum furnaces. Inert gas furnaces are preferred because of the heating characteristics of the molds. Vacuum furnaces have also been used, but it is more difficult to control glass slumping rate. Other types of furnaces usually introduce contaminants into the slumping environment that degrade glass surface quality. Mold temperature, which is critical to glass quality and accuracy, is also difficult to control in other types of furnaces.

Cleanliness of the molds, glass, and furnace is critical to glass quality. These components should be thoroughly cleaned at the beginning of every slumping operation.



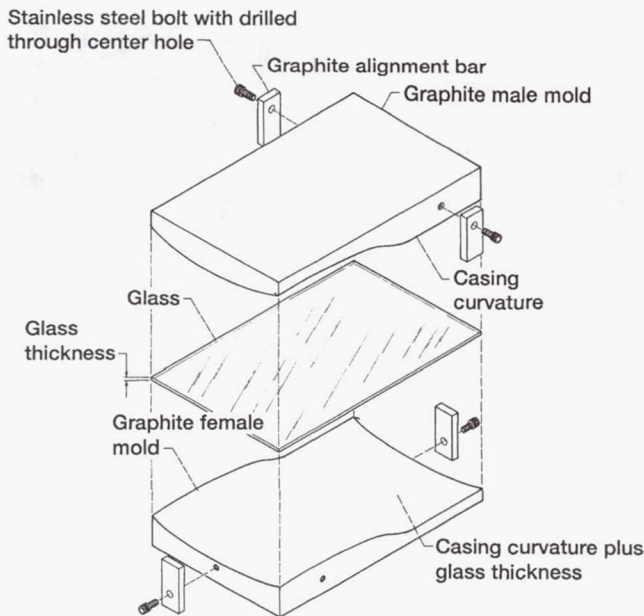

Figure 5.—Slumping components configuration.

The forming temperature of laser windows is found by an iterative process. The mean annealing temperature of about 1100 °F is the theoretical starting temperature for new laser window formation. Adequate visual inspection of the window after formation will indicate whether the slumping temperature should be increased or decreased. The ideal slumping temperature for compound-curvature laser window formation is usually within 2 percent of the annealing temperature.

The procedure for laser window formation is as follows:

- (1) Cut the glass to overall mold dimensions, that is, 1 in. greater than the final window design dimensions.
- (2) Thoroughly clean the glass with soap and water. Oil from fingers will develop into surface imperfections during the slumping operation.
- (3) Thoroughly clean the male and female molds with an alcohol-based cleaner.
- (4) Thoroughly clean the inert gas furnace.
- (5) Bolt the alignment bars onto the molds.
- (6) Position the male mold into the inert gas furnace.
- (7) Insert the glass on top of the male mold.
- (8) Position the female mold onto the male mold with the glass positioned in between them.
- (9) Heat the furnace to slumping temperature.
- (10) Soak the glass at slumping temperature for 4 to 6 hr.
- (11) Cool the glass down to ambient temperature.
- (12) Examine the slumped glass for proper curvature and quality.
- (13) After desired curvature and quality are obtained, anneal the glass to relieve residual stresses.

Visual inspection of the slumped laser window will provide adequate information to alter the slumping temperature. If the slumping temperature is excessive, surface imperfections will

be apparent. These surface imperfections will appear along the plane of severe compound curvature or inflection point. This problem can be solved by decreasing the slumping temperature by 1 to 2 percent of the annealing temperature.

The combination of inadequate slumping temperature and excessive mold pressure may result in low-quality laser windows. These laser windows will appear wavy in the area where the glass was stretched. The solution to this problem is to increase slumping temperature and duration for glass formation.

The laser windows can be molded in several steps by alternating slumping temperature, modifying slump soak time, varying molding force, inverting mold positions, or any combination of these methods. When molding glass in several steps, the female mold is always used first and by itself. After the glass is partially formed, the male mold is added, the entire assembly is inverted, and the slumping process is then repeated. Laser windows with extreme curvature or compound curvature may require repeated slumping operations. These complex windows often require the addition of weight to the molds to adequately form the glass.

Laser window formation can be a lengthy process, but once the parameters are found for a particular laser window, reproduction is routine. The last process in the formulation of laser windows is to anneal the glass. This relieves residual stresses developed in the glass during the formation process. Glass annealing also helps achieve glass strength consistencies from one laser window to another.

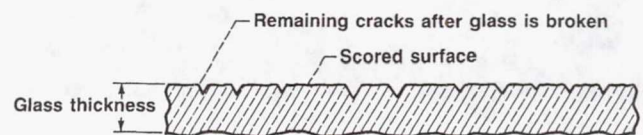

Figure 6.—Edged window glass by scoring.

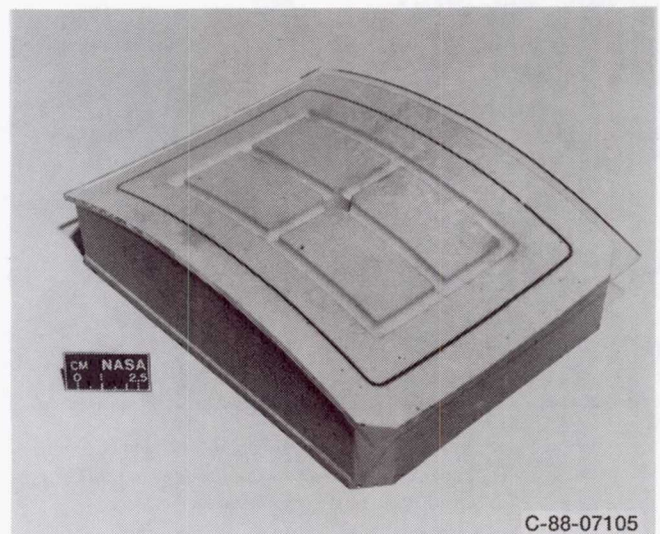

Figure 7.—Laser window glass and transfer mold.



## Glass Edging

Previous methods of edging the laser windows to size involved scoring the glass to the desired size, then breaking the glass along this scored edge. During this process, small fragments of glass are broken away along the line of scoring, creating voids in the glass. The glass then breaks along these voids because it is the path of least resistance and strength. Unfortunately, minute cracks along the edge of the glass remain after the glass is broken (fig. 6). These cracks weaken the glass and cause failure of the glass under load.

Minimizing cracks is important during the edging process. A perfected process for edging glass using a numerically controlled water-jet cutting machine has been developed and is recommended for cutting laser windows. The machine abrades glass away along the desired cut line, reducing glass fragmentation. The water-jet cut edge of the glass is less densely populated with cracks, and crack penetration is less severe when compared with scored glass.

The compound curvatures of some laser windows necessitate using a transfer mold to locate the desired cutting line. The transfer molds are machined out of proof board to the same dimensions as the male formation mold and with the desired cut line marked on the surface. Figure 7 shows a formed piece of laser window glass on top of a transfer mold. The desired cut line is transferred onto the laser window glass using layout dye.

Positioning of the laser window glass for edging with a water-jet cutting machine is shown in figure 8. The desired laser window dimensions are programmed into the numerically controlled water-jet cutting machine. To alleviate laser window glass damage from the backslash of the water jet, a 0.0625-in.-thick aluminum plate is placed across the ways of the water-jet cutting machine bed. To protect the glass from fracturing, duct seal is placed over the surface of the aluminum plate to absorb the high cutting frequencies of the water jet. The laser window glass is then secured into position by pressing it into the duct seal. Figure 9 shows a cross section of the edging process. The maximum desired water-jet cutting rate for edging laser window glass is 4.75-in./min, with a nozzle pressure of 30 000 psig.

After the laser window glass is cut to size, the edges are rounded. Using aluminum oxide or diamond-coated sanding belts helps protect the glass from damage because glass edges are most susceptible to impairment. The minimum radius of the rounded edges is equivalent to half the glass thickness, as shown in figure 10.

## Glass Strengthening

Chemical strengthening of the glass through ion exchange is a readily available technology. The process will only be highlighted in this report; detailed information is given in references 3 to 8.

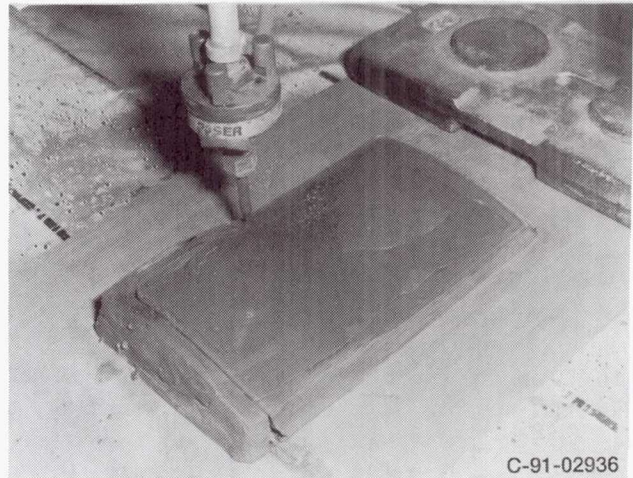

Figure 8.—Laser window glass positioned for edging in numerically controlled water-jet cutting machine.

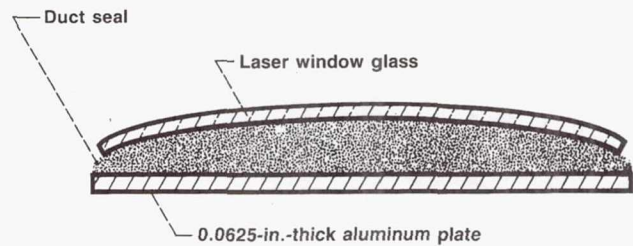

Figure 9.—Cross section of laser window edging process.

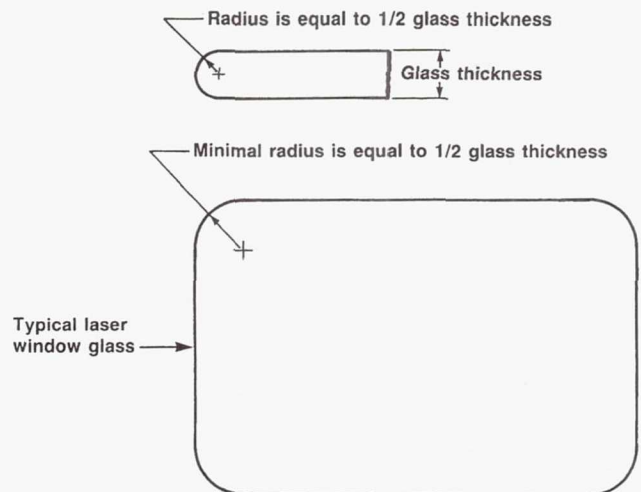

Figure 10.—Rounded edges of typical laser window.

Laser windows are chemically strengthened through ion exchange to endure facility operating pressures and temperatures, and to increase their relative impact strength. These windows are chemically strengthened to contain a 0.010-in. or greater compression layer. This compression layer is the



depth of ion exchange, which gives the glass its increased strength and resilience. The specially designed chemical composition of Corning glass code 0317 sodium-alumino-silicate glass enhances this ion exchange to ensure maximized glass strength. This is the principal reason why this glass is used for laser window formation.

Sodium-based glass is submersed in a potassium nitrate bath (molten salt), where the ion exchange between sodium and potassium ions commences. Glass strength is achieved by the crowding of larger potassium ions from this ion exchange into the surface of the sodium-alumino-silicate glass. An illustration of this ion exchange is shown in figure 11.

The failure of chemically strengthened glass can occur only when the pre-stress from compression is canceled and exceeded by a greater tensile force. Since laser windows are chemically strengthened to have an approximate 0.010-in. compression layer, they are inherently very strong. For one of these chemically strengthened windows to fail, it would have to be excessively loaded or impacted with an object capable of penetrating the compression layer.

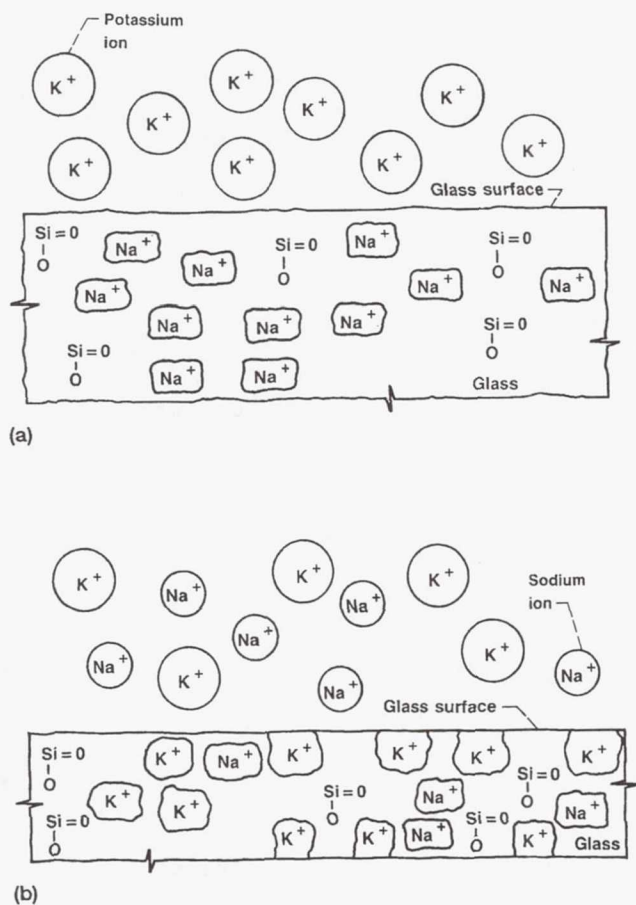

(a) Preceding ion exchange.  
 (b) Subsequent ion exchange.

Figure 11.—Ion exchange during chemical strengthening process.

## Glass Bonding to Frame

The laser window frames are specially designed to pocket and hold the glass. Figure 12 shows this unique design. The laser window glass is bonded to the window frame using a high-strength semiflexible adhesive. The laser window glass is actually floated in the laser window frame with 0.030- to 0.050-in. bonding medium between the laser window glass and all laser window frame surfaces. Figure 13 shows a cross section of the laser window frame, glass, and bonding medium. The bonding strength is increased drastically by a semi-spherical groove located in the lower and inner edge of the laser window frame. This groove acts as a molded half O-ring, which must shear for a total bonding medium to fail. The combination of tensile and shear force needed for bonding medium failure under load gives an ultimate adhesive strength. Past designs did not incorporate this feature that increases bonding strength while maintaining similar overall bonding area. The ideal bonding area is 1 in. over all bonding surfaces (fig. 4). In theory, large bonding areas are always preferred, but they are sometimes impractical because of design constraints. The bonding medium should be semiflexible to absorb forces which could end-load and break the laser window glass.

Accurate positioning of laser window glass into the frame is a crucial step in obtaining quality laser data. Inappropriate positioning may create undesirable steps and transitions that may disturb the airflow in the compressors and turbines. Laser window glass can be positioned precisely by using a specifically designed gluing fixture to hold the alignment of the laser window glass with respect to the laser window frame. Gluing fixtures are machined out of aluminum and to the identical contour and dimensions of the male molds. (See fig. 14.)

Figure 15 shows the assembly stackup for bonding the laser window glass to the frame. The gluing fixture has an inscribed inner channel 0.125 in. in depth which matches the circumference of the laser window glass. Without this escape channel, bonding medium would get trapped over the frame or glass, resulting in a nonuniform transition between the laser window glass and frame. Additional channels provide the escaping bonding medium a passage to the outer perimeters of the gluing fixture when the window glass and frame are assembled. Duct seal is used to hold the alignment of the laser window glass to the gluing fixture.

Figure 16 represents a cross section of the bonding process. The laser window glass is aligned onto the gluing fixture by positioning the outer perimeter of the laser window glass with the inner edge of the bonding medium escape channel. The bonding medium is then applied to the supporting edge of the laser window frame. The frame is aligned on the gluing fixture using dowel pins. The dowel pins have a 0.001-in. clearance with the laser window frame's other side walls.

Equipment cleanliness is important during all facets of the bonding process. If an insufficient bond is made, the bond,



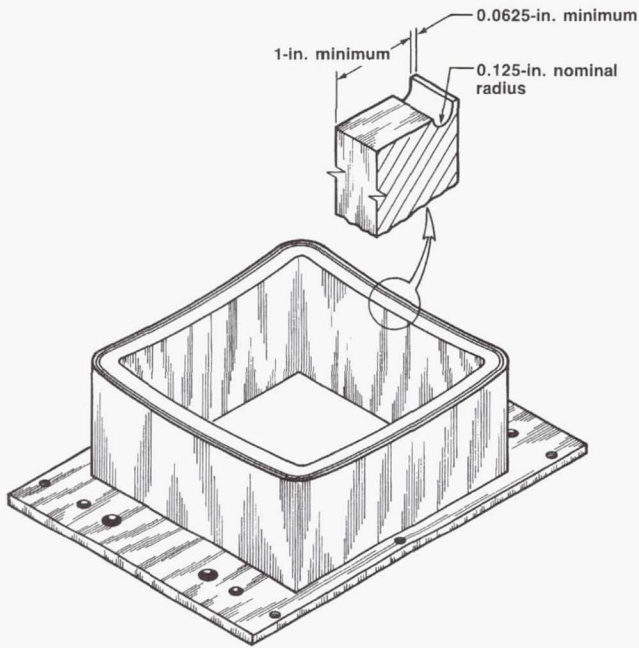

Figure 12.—Typical laser window frame.

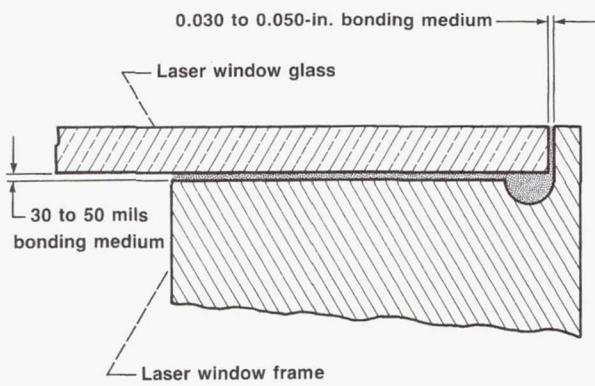

Figure 13.—Cross section of laser window frame, glass, and bonding medium.

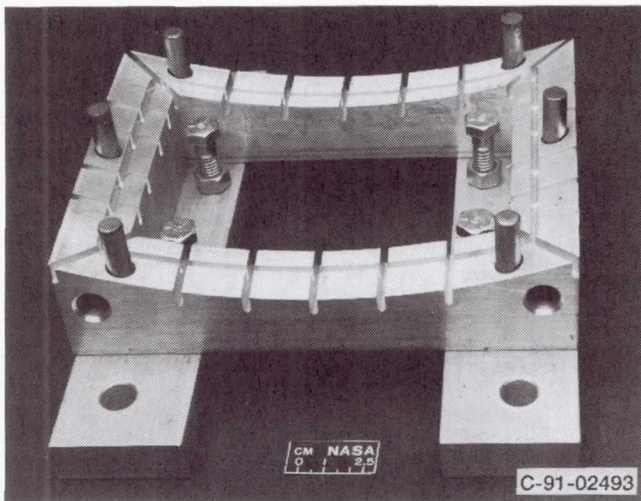

Figure 14.—Typical laser window gluing fixture.

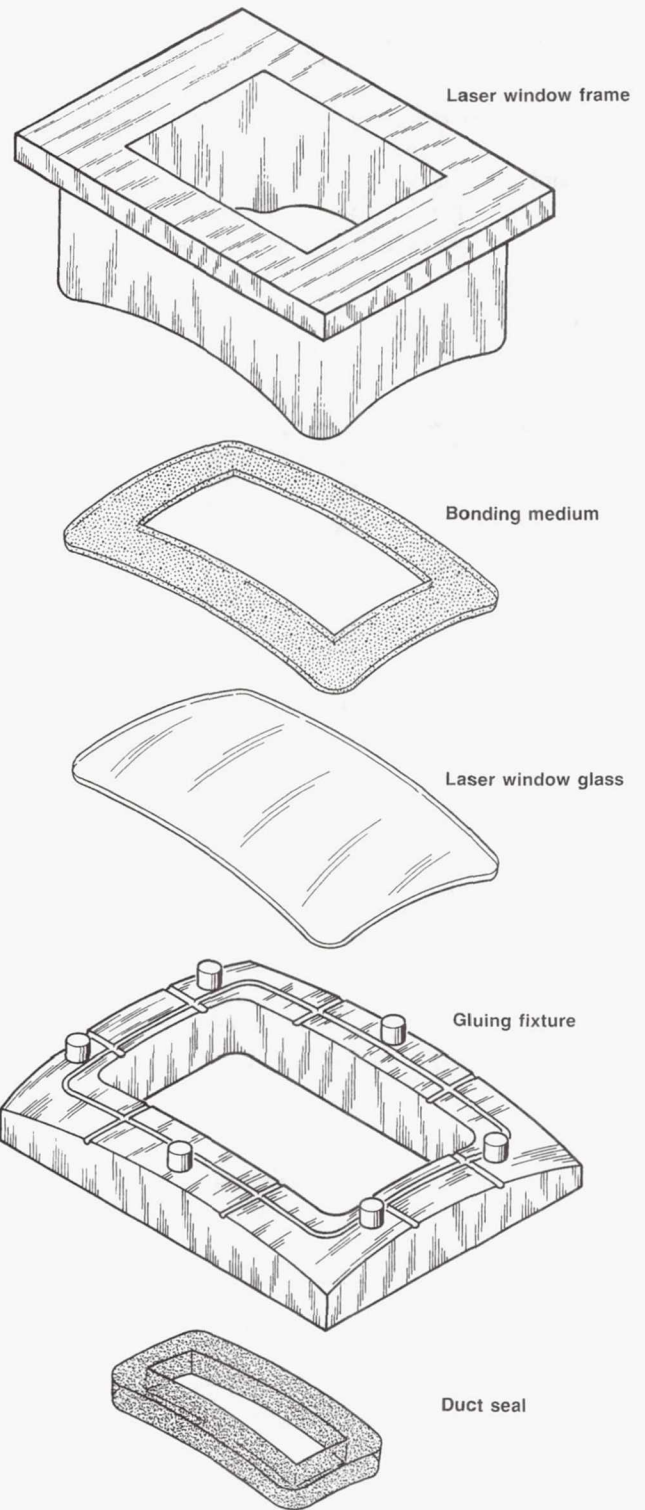

Figure 15.—Assembly stackup of laser window bonding process.

glass, or both will probably fail proof testing. If this happens, the entire laser window formation process must be repeated.

## Window Proof-Testing Procedure

At Lewis Research Center, the turbine and compressor casings into which the laser windows are located are evaluated in accordance with boiler vessel codes to ensure their structural integrity and safety. The normal process for evaluating facility hardware is hydrostatic testing. To uphold the structural

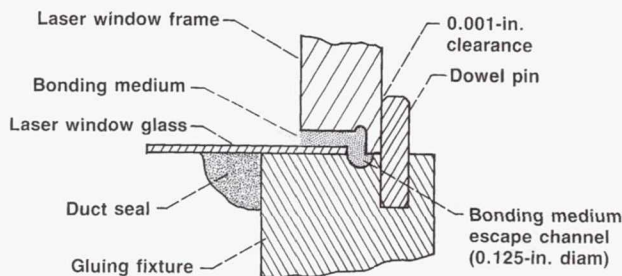

Figure 16.—Cross section of laser window bonding process.

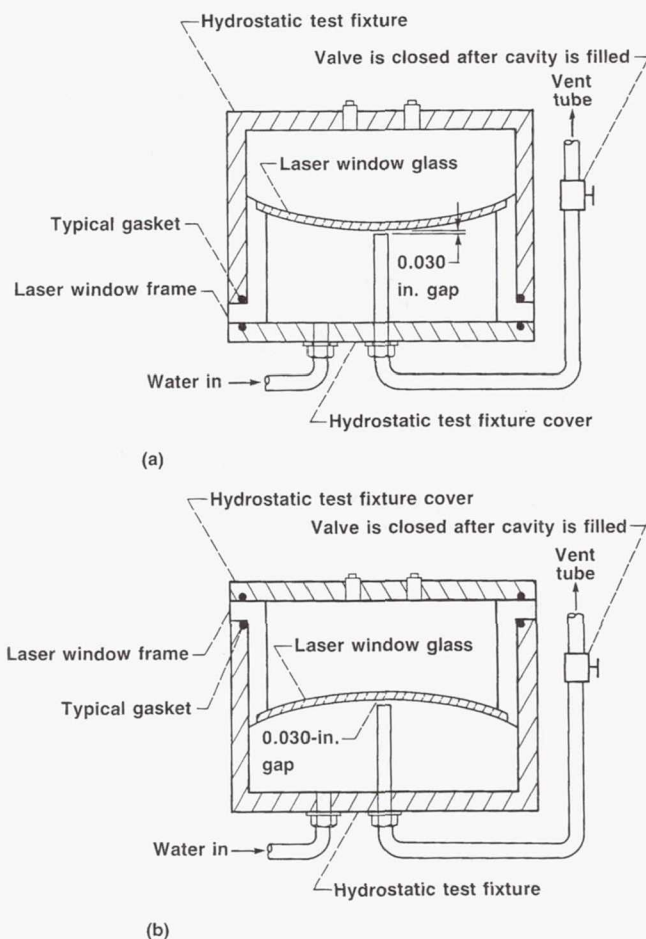

Figure 17.—Typical laser window hydrostatic test configuration.

integrity and safety of these facilities, the laser windows are also hydrostatically tested.

Hydrostatic testing of laser window glass is an ideal process for evaluating the integrity of the glass because sodium-silicate-based glass forms a hydroxide chemical bond that is typically not present under normal conditions. Hydroxide bonds are relatively weak chemical bonds. When glass is submerged in water, the surface of the glass chemically bonds with sodium hydroxide (ref. 3). Cracks in the laser window glass would also incorporate this hydroxide bond. During hydrostatic testing of the laser windows, these cracks will propagate because of the weakening of the glass by this hydroxide bond and the hydrostatic testing procedure.

Laser windows require hydrostatic proof-testing to ensure that they can structurally withstand the "worst-case" differential pressure condition. When performing this hydrostatic test, reference is made to gage pressure rather than absolute pressure. Ordinarily, the convex (outside) surface will be at ambient pressure (zero gage pressure), since it is generally exposed to the test cell environment. The concave (inside) surface can be exposed to pressures below or above zero gage pressure, since it experiences the range of test rig operating pressures. When the concave surface is exposed to above zero gage pressures, it is proof-tested to 1.5 times the maximum gage pressure it may experience, and the convex surface does not require proof-testing. When the concave surface is exposed to below zero gage pressures, this surface does not require proof-testing. Rather, the convex surface is proof-tested to a positive gage pressure equal to 1.5 times the minimum gage pressure the concave surface is exposed to. If the concave surface is exposed to both below and above zero gage pressures, then both surfaces have to be individually proof-tested to the levels stated here for each surface.

Figure 17 shows a typical hydrostatic test configuration for evaluating concave and convex surfaces of laser windows. The proof tests consist of increasing the test pressure in 5-psi increments to maximum proof pressure for 10 consecutive cycles. The soaking time at each increment period is between 1 and 5 min. At the last cycle's maximum proof-test point, the pressure is held for a minimum of 1 hr. If elevated temperatures are a primary concern, then the laser window should be qualified by repeating this pressure evaluation procedure with the addition of an induced elevated temperature. A visual inspection of the laser windows should be conducted after evaluation testing to check for bonding medium and glass integrity.

## Concluding Remarks

High-quality contoured windows are a key part of laser anemometry systems for compressor and turbine facilities. The present formation process ensures accurate tolerances and flawless quality of these laser windows. Although they are tested for flaws, laser windows should be considered and



treated as a fragile material. Routine visual inspection and hydrostatic evaluations are considered important to their integrity.

Future experiments indicate the need for larger laser windows to increase the fields of unobstructed view. Future windows must also endure higher pressures and temperature gradients. With the present formation processes, these laser windows should successfully withstand these future requirements.

Lewis Research Center  
National Aeronautics and Space Administration  
Cleveland, Ohio, April 14, 1992

## Acknowledgements

The author is indebted to his NASA Lewis Research Center colleague David Kowalski for his assistance with the perfected three-dimensional laser window formation process.

## References

1. Bueche, F.J.: Introduction to Physics for Scientists and Engineers. Third ed. McGraw Hill, 1980, pp. 614-634.
2. Corning, Inc.: Corning Glass Code 0317 Specification Sheet. Corning, New York, 1990.
3. McLellan, I.; and Shgnd, G.W. II: Glass Engineering Handbook. Third ed. McGraw Hill, 1984.
4. Nordberg, M.E., et al.: Strengthening by Ion Exchange. Am. Ceram. Soc. J., vol. 47, no. 5, May 1964, pp. 215-219.
5. Hagy, H.E.: Design Strength of a Chemically Strengthened Glass. Central Glass Ceram. Res. Inst. Bull., vol 13, no. 1, 1966, pp. 29-31.
6. Blizard, J.R.: Chemically Strengthened Glass, SAE Paper 680485, 1968.
7. Miska, H.A.: Understanding the Basics of Chemically Strengthened Glass. Mater. Eng., vol. 83, no. 6, 1976, pp.38-40.
8. Olcott, J.S.: Strengthening of Glass. Science, vol. 140, no. 3572, June 14, 1963, pp. 1189-1193.

REPORT DOCUMENTATION PAGE			Form Approved OMB No. 0704-0188	
Public reporting burden for this collection of information is estimated to average 1 hour per response, including the time for reviewing instructions, searching existing data sources, gathering and maintaining the data needed, and completing and reviewing the collection of information. Send comments regarding this burden estimate or any other aspect of this collection of information, including suggestions for reducing this burden, to Washington Headquarters Services, Directorate for Information Operations and Reports, 1215 Jefferson Davis Highway, Suite 1204, Arlington, VA 22202-4302, and to the Office of Management and Budget, Paperwork Reduction Project (0704-0188), Washington, DC 20503.				
1. AGENCY USE ONLY (Leave blank)	2. REPORT DATE July 1992	3. REPORT TYPE AND DATES COVERED Reference Publication		
4. TITLE AND SUBTITLE Three-Dimensional Laser Window Formation		5. FUNDING NUMBERS WU-505-62-84		
6. AUTHOR(S) Vincent G. Verhoff				
7. PERFORMING ORGANIZATION NAME(S) AND ADDRESS(ES) National Aeronautics and Space Administration Lewis Research Center Cleveland, Ohio 44135-3191		8. PERFORMING ORGANIZATION REPORT NUMBER E-6096		
9. SPONSORING/MONITORING AGENCY NAMES(S) AND ADDRESS(ES) National Aeronautics and Space Administration Washington, D.C. 20546-0001		10. SPONSORING/MONITORING AGENCY REPORT NUMBER NASA RP-1280		
11. SUPPLEMENTARY NOTES Responsible person, Vincent G. Verhoff, (216) 433-5708.				
12a. DISTRIBUTION/AVAILABILITY STATEMENT Unclassified - Unlimited Subject Categories 14 and 37		12b. DISTRIBUTION CODE		
13. ABSTRACT (Maximum 200 words) The NASA Lewis Research Center has developed and implemented a unique process for forming flawless three-dimensional laser windows. These windows represent a major part of specialized, nonintrusive laser data acquisition systems used in a variety of compressor and turbine research test facilities. This report discusses in detail the aspects of three-dimensional laser window formation. It focuses on the unique methodology and the peculiarities associated with the formation of these windows. Included in this discussion are the design criteria, bonding mediums, and evaluation testing for three-dimensional laser windows.				
14. SUBJECT TERMS Windows; Laser windows; Three-dimensional glass; Curved glass; Slumped glass; Molded glass; Chemical strengthening of glass			15. NUMBER OF PAGES 16	
			16. PRICE CODE A03	
17. SECURITY CLASSIFICATION OF REPORT Unclassified	18. SECURITY CLASSIFICATION OF THIS PAGE Unclassified	19. SECURITY CLASSIFICATION OF ABSTRACT Unclassified	20. LIMITATION OF ABSTRACT	