

116440
P. 19

NASA Technical Memorandum 105789

Life Extending Control for Rocket Engines

C.F. Lorenzo and J.R. Saus
*Lewis Research Center
Cleveland, Ohio*

and

A. Ray, M. Carpino, and M.-K. Wu
*Penn State University
University Park, Pennsylvania*

August 1992

(NASA-TM-105789) LIFE EXTENDING
CONTROL FOR ROCKET ENGINES (NASA)
19 9

492-31263

Unclass



G3/31 0116440



Life Extending Control for Rocket Engines

C. F. Lorenzo & J. R. Saus
NASA Lewis Research Center
Mail Stop 77-1, 21000 Brookpark Rd.
Cleveland, Ohio 44135

A. Ray, M. Carpino, M.-K. Wu
Penn State University

ABSTRACT

The concept of Life Extending Control is defined. A brief discussion of current fatigue life prediction methods is given and the need for an alternative life prediction model based on a continuous functional relationship is established. Two approaches to life extending control are considered: The Implicit Approach uses cyclic fatigue life prediction as a basis for control design. A second approach called the Continuous Life Prediction Approach which requires a continuous damage law is also discussed. Progress on an initial formulation of a continuous (in time) fatigue model is presented. Finally, non-linear programming is used to develop initial results for life extension for a simplified rocket engine (model).

INTRODUCTION

Systems with high performance requirements, such as Space Shuttle Main Engine (SSME) or Hypersonic Propulsion Systems, often have a small number of critical components that operate close to mechanical design limits and that define the effective lifetime of the system. In particular these components are often maximally stressed through transients and it is during the transients that large decrements in component life are experienced. The effect of thermal transient loading on SSME turbine blades is a typical example. It is against the backdrop of the durability problems of the SSME that the concept of Life Extending Control (LEC) has evolved. However, it clearly has applicability to a broad range of mechanical/thermodynamic systems. The fundamental concept of life extending control is to control rates of change and levels of some performance variables to minimize damage (or damage rates) of critical components while simultaneously maximizing dynamic performance of the plant.

BACKGROUND

The fundamental concept of life extending control has been forwarded in references (1-3) by Lorenzo & Merrill. Two basic approaches have been considered 1.) Implicit Life Extending Control, which uses current cycle based damage laws and 2) Direct Life Extending Control which assumes the development of a continuous form damage law. The continuous damage form will allow a more straightforward development of the Life Extending Control concept and a much simpler implementation.

In the paper that follows, the Life Extending Control concept will be reiterated briefly.

The potential durability improvement possible with these concepts has been demonstrated on simplified applications [Ref 1]. This paper will show current work applying the Implicit Life Extending Control.

A continuous damage model being developed for controls use will be discussed. This model allows the intra-cycle damage to be expressed in terms of the cyclic extrema and the stress level.

Finally, preliminary results for life extension for a Simplified Reusable Rocket Engine will be presented. The results are those which will lead to a Direct Life Extending Control method and may have near term application for a minimal damage start-up/shut-down sequence.

LIFE PREDICTION

Both the basics of a current theory (cyclic) for life prediction (or damage model) and the results of a proposed extension (to a non-cyclic continuous model) of this theory are presented.

CURRENT LIFE PREDICTION APPROACH

The cyclic life prediction process is highly nonlinear and comes from the study of metal fatigue due to cyclic loading. The material that follows is based on the local strain approach and substantially follows reference [4].

Usually the life estimates that result are used to forecast service life for a particular component design. Here that estimate will be calculated and used directly to manage life as the component undergoes transient loading during system operation. It is assumed to simplify the analysis that the life calculations can be based upon the stresses and strains estimated to occur locally at critical points. This is a typical assumption used in life prediction analysis. The detailed procedure for life prediction is complicated and depends on many factors.

A simplified version of the procedure for life calculation is as follows. For cyclic (stress-strain) loading, Fig (1), first the local strain, ϵ , is calculated from the load history, F , by

$$\delta e = \frac{\delta F}{c_1} + \left(\frac{\delta F}{c_2} \right)^{\frac{1}{d}} \quad (1)$$

where c_1 , c_2 , and d are constants that depend upon the material and

$$\delta e = \frac{e - e_r}{2}; \quad \delta F = \frac{F - F_r}{2} \quad (2)$$

with the subscript r indicating a reference point. The determination of the reference point is critical to the calculation procedure and involves a careful ordering of the hysteresis-like stress-strain cycles by magnitude and direction. These cycles, Fig (2), are described by

$$\delta e = \frac{\delta \sigma}{E} + \left(\frac{\delta \sigma}{A} \right)^{\frac{1}{s}} \quad (3)$$

where σ is the stress, $\delta \sigma = (\sigma - \sigma_r)/2$, and E , A , and s are material constants. Once the stress-strain cycles are calculated, the life usage associated with a single cycle of the given load history can be estimated from

$$\delta e = \left(\frac{\sigma'_f - \sigma_{ave}}{E} \right) \left(\frac{D_i}{2} \right)^{-b} + \epsilon'_f \left(\frac{\sigma'_f - \sigma_{ave}}{\sigma'_f} \right)^{cb} \left(\frac{D_i}{2} \right)^{-c} \quad (4)$$

Here σ'_f , b , ϵ'_f , and c are material constants, D_i is the life lost due to cycle i , hereafter called damage, and σ_{ave} is an average tensile stress which is used to correct for nonzero mean tensile stresses in predominately elastic cycles. Once the cyclic analysis has been completed, total damage may be estimated by

$$D = \sum_i D_i \quad (5)$$

using the Palmgren-Miner approach (Ref 4). Other, more accurate and complex approaches to determining total damage given the cyclic analysis are possible (Ref 5).

The procedure of equations (1)-(5) can be solved at discrete instances of time, i.e. whenever a stress-strain cycle has been completed, either by a traditional computing approach or by a neural network. This dependence on cycle closure for updating the effect of loading on component life makes a direct application of the current life estimation procedure to life extending control impossible. An indirect application is possible and will be described in a later section. However, the direct application of a life estimation procedure to control would be more beneficial and is therefore the ultimate goal of damage modelling for life extending control. To accomplish this goal, a new formulation of the life estimation procedure is required. This new formulation would consist of a continuous form of the damage laws instead of the current forms which require bookkeeping the number of cycles, their respective amplitudes, and their order of occurrence.

CONTINUOUS LIFE PREDICTION APPROACH

In the concepts that follow, the need for a continuous (non-cyclic) form for the damage relations will be apparent. Specifically, in order to control damage accumulation it is necessary to know for the next increment of time the damage effect, D , for any chosen control action U , fig 3. This requires a functional relationship (in terms of differential rates) of damage with measurable variables, (eg. stress or strain).

Initial efforts in this regard have derived the following damage law. This form has been derived by comparing two stress-strain cycles that differ by a small incremental strain (or stress), see figure 4. The details of the derivation may be found in reference [6].

$$\frac{dD}{dt} = W \frac{d\delta_e}{dt} + (1-W) \frac{d\delta_p}{dt} \quad (6a)$$

where δ_e and δ_p represent damages due to the "elastic" and "plastic" effects respectively, and

$$W = \frac{|\epsilon_e - \epsilon_{re}|}{|\epsilon - \epsilon_r|} \quad \text{and} \quad 1-W = \frac{|\epsilon_p - \epsilon_{rp}|}{|\epsilon - \epsilon_r|} \quad (6b)$$

and

$$d\delta_e = \frac{\partial \delta_e}{\partial \sigma} d\sigma + \frac{\partial \delta_e}{\partial \sigma_r} d\sigma_r \quad (6c)$$

$$d\delta_p = \frac{\partial \delta_p}{\partial \sigma} d\sigma + \frac{\partial \delta_p}{\partial \sigma_r} d\sigma_r$$

The $d\sigma_r$ terms bring in the effect of the change of reference points (σ_r which are the stress extrema), these are zero between extrema.

Finally the total derivatives $d\delta_e/dt$ and $d\delta_p/dt$ in Eq. (6c) are evaluated from the respective partial derivatives:

$$\frac{\partial \delta_e}{\partial \sigma} = -\frac{2}{b} \times \frac{(\sigma'_f - \sigma_r)}{(2\sigma'_f - \sigma - \sigma_r)^2} \times \left(\frac{|\sigma - \sigma_r|}{2\sigma'_f - \sigma - \sigma_r} \right)^{-\left(\frac{b-1}{b}\right)} \text{sgn}(\sigma - \sigma_r) \quad (6d)$$

$$\frac{\partial \delta_p}{\partial \sigma} = \left(\frac{1}{\epsilon'_f} \right)^{-\frac{1}{c}} \times \left\{ -\frac{\text{sgn}(\sigma - \sigma_r)}{2K'n'c} \times \left(\frac{|\sigma - \sigma_r|}{2K'} \right)^{-\frac{1}{n'c} - 1} \times \left(\frac{2\sigma'_f - \sigma - \sigma_r}{2\sigma'_f} \right)^{\frac{1}{b}} - \frac{1}{2\sigma'_f b} \left(\frac{|\sigma - \sigma_r|}{2K'} \right)^{-\frac{1}{n'c}} \times \left(\frac{2\sigma'_f - \sigma - \sigma_r}{2\sigma'_f} \right)^{\frac{1}{b} - 1} \right\}$$

These equations can then be used to obtain the damage rate at any instant.

LIFE EXTENDING CONTROL

The fundamental concept of life extending control is to control rates of change and levels of some performance variables to minimize damage (or damage rates) of critical components while simultaneously maximizing dynamic performance of the plant. It is emphasized that a fundamental tradeoff exists between the level of achievable performance and the ability to extend the life of system components generating that performance.

Since the life prediction procedure is grossly nonlinear and is intimately connected with the determination of stress-strain hysteresis cycles, any control strategy will depend upon the total time history of the force applied to the critical component. However, as long as some flexibility in obtaining system transient performance exists, the opportunity to manage life usage exists. A study of the life prediction procedure indicates two factors which will be important when devising a control strategy, strain cycle magnitude and average (mean) tensile stress.

From figure 5, which is a solution of equation (4), it is clear that life usage is directly related to strain magnitude. Strain magnitude is directly related to force. Thus, a control which minimizes forces applied to the critical component will extend life. This is hardly remarkable. However, LEC allows a comparison of two different control objectives based upon a quantitative analysis of the forces required to accomplish the different objectives. As assumed in this work, the time to achieve control performance can be varied to manage the forces and therefore the life of the critical component. In this way total system performance over the life of the component can be maximized.

Also, from figure 5, it can be seen that nonzero mean tensile stress (MTS) applied during predominately elastic load cycles can substantially degrade life. For example if a particular commanded trajectory has left the component with a nonzero average tensile stress, small force perturbations will be more damaging than if they occur after a commanded trajectory that results in an average compressive stress. This shows clearly the need to manage the operating domain (level) as well as cyclic amplitude.

A third factor, not explicitly shown by the equations, is component temperature. Higher component temperatures can have a marked effect on life usage. Higher temperatures change the material property constants in equations (1)-(4) and increase the life usage for comparable values of strain. These effects, although important, will not be considered in this paper. The basic ideas of life extending control can be more effectively illustrated without the consideration of this additional factor.

Two general approaches to LEC are presented. The first is based on the cyclic life prediction approach and is called the Implicit Approach. Assuming the existence of the continuous life prediction approach, an additional concept for Life Extending Control is presented. This is called Direct Life Extending Control.

IMPLICIT LEC

The implicit approach to Life Extending Control recognizes that current fracture/fatigue science cannot predict the differential damage on less than a full cycle of strain. The implicit approach (see figure 6) selects a sequence of typical command transients (and disturbances) that are representative of those the system would experience in service. Two performance measures are defined: J_p , an objective function that maximizes dynamic performance (possibly by

minimizing quadratic state and control excursions) and, J_D , a damage measure which uses the best (current) fatigue/fracture theory available to calculate the damage accumulated over the sequence of command transients. An overall performance measure can also be defined as

$$J = J_p + aJ_D \quad (7)$$

where a represents the relative importance between performance and life extension. The implicit approach then selects a "best" control algorithm which is applied for the full sequence of command transients. The dynamic performance and damage accumulation over the sequence are optimized (relative to the selected measures) against the control algorithm parameters. The expectation is to find an algorithm such that the loss in dynamic performance is small (i.e., $J_{p,z,min} - J_{p,o,min}$ in figure 7), for a significant reduction in accumulated damage over the sequence of transients (i.e., $J_{D,o,min} - J_{D,z,min}$ is large and life is extended). Here the subscript o refers to optimizing for dynamic performance only. An actual operating gain set (point q in figure 7) is then chosen which satisfies the desired weighing between performance and damage (i.e. J). The mechanics of the implicit approach are detailed as follows. During the design process, two types of feedback variables are considered: 1) the performance variables normally used to manage dynamic performance and 2) nonlinear functions of the performance variables representative of the damage variables (stresses, strains, temperature and various rates). Various control algorithms are then examined within this feedback structure. That is, the sequence of selected performance and disturbance transients are applied to a simulated system with a trial control and performance J (or J_p and J_D separately) is calculated. Superior LEC algorithms can then be identified as those that minimize J (or J_p and J_D separately). A family of algorithms can be developed which are parameterized by the relative tradeoff parameter a . The final control can be selected from this set of algorithms with confidence that an effective control and a desirable performance/life tradeoff have been established.

Intuitive LEC algorithms are readily formulated. Clearly minimizing the mean tensile stress, mean strain, and temperature levels and minimizing the cyclic amplitude of stress, strain, and temperature should minimize damage. Also, minimizing the number of cycles of stress and strain should contribute to extending critical component life.

An example study (ref 1) of a load positioning control (actuator) indicated the ability to substantially extend critical component life (about two times) at very small cost in dynamic response. This study indicated the potential of the above LEC approach.

CYCLIC DAMAGE ESTIMATOR

The calculation of cyclic damage is required in the Implicit LEC approach for off-line optimization. It is also a real-time element of the Life Management Life Extending Control Concept (Ref 1).

A neural damage estimator, capable of assessing temperature-influenced, cyclic damage, at a critical point has been developed (Fig. 8). For this estimation, temperature from a monitored location is used with known functional relationships to generate temperature dependent values for material properties such as Young's Modulus, ultimate tensile stress, etc. These properties are then used with the nominal stress of the critical component and an a priori geometry-specific stress concentration factor, k_t , in a neural net (trained) to map nominal stress into local stress and strain in accordance with Neuber's Rule.

The extrema detector monitors nominal stress to determine cycle extrema and "tags" the local strain values at the extrema for use in a subsequent damage calculation. Also the cycle local mean stress is determined. These values together with temperature sensitive material properties are then used as inputs to a neural net trained to map the values into cycle damage. The mapping is consistent with Dowling's Local Strain Approach Ref [4]. Accumulated damage is then determined by post-processing the cycle damage by a damage accumulation law such as Palmgren-Miner, Double Linear Damage Rule, etc..

DIRECT LIFE EXTENDING CONTROL

The Implicit Life Extending Control approach does not directly control (or limit) the damage rates of critical components. Direct control requires a continuous form of the damage laws instead of the cyclic forms. While a simple, unreferenced continuous damage model is still needed, the damage model forwarded in the previous section allows progress toward direct life extending control.

MEASURED DAMAGE VARIABLES LIFE EXTENDING CONTROL

In this approach (figure 9) both the plant performance and the damage (measured stresses, strains, temperatures, forces, etc.) related variables associated with critical components are measured and used as feedback information for the control. Here the control attempts to directly regulate life as a resource rather than indirectly as in the previous approaches. It is presumed that a "real-time" predictive damage (or life) model (described above) exists that would allow the prediction of the incremental damage (or local Damage rates $\dot{D}_1, \dot{D}_2, \dots$) as a continuous function of measured stresses, strains and temperatures. Also, the influence of changes in the performance variables (presumed to be controllable) on the behavior of the critical life variables is known. Thus, in figure 3, at time A, the damage associated with damage variable D_1 can be predicted for any control action (here actions u_1, u_2 , and u_3 are considered and result in damages D_1, D_2 , and D_3 , respectively). (Note, damage while shown as a continuous function of time, will likely be modelled as a continuous function of local stress, strain, etc.) The control problem then is to minimize damage of the critical life components while maximizing (dynamic) performance of the plant. The performance objective approach of equation (7) can be used to achieve this optimization.

One implementation of a measured damage variables LEC would achieve control performance by adaptively modifying the control feedback structure to permit damage to accumulate at a "setpoint" rate, a linear rate over time for example. The measured damage variables could be used directly in a feedback law or to modify the gains or even the structure of the existing control. The emphasis here is on obtaining desired system operation by an active, feedback control approach. The issue of controllability is fundamental to such an approach.

ESTIMATED DAMAGE VARIABLES LIFE EXTENDING CONTROL

Unlike the Measured Damage Variables LEC approach, this concept, shown in figure 10 uses a real time model to estimate the damage rates (and damage accumulation) of critical components. The models can be driven by performance variables or performance variables augmented by available damage measures. Conceptually the structural models can vary from simple, precomputed, linear, influence coefficients to detailed, non-linear, real time structural models which may require considerable computation. The damage estimator would be a direct consequence of the continuous life model described previously and would result in real time damage rate estimates based on measured performance variables and/or a structural dynamic model output. The controller design would follow in much the same manner as for the measured damage variables approach.

ROCKET ENGINE LIFE EXTENSION

The example that follows establishes the preliminaries for Direct Life Extending Control for Rocket Engines. A simplified (monopropellant) rocket engine dynamic model is shown in figure 11. Here a gas generator provides the drive gas for a fuel (LH_2) turbopump. Presently, oxidant is separately supplied to both the gas generator and the main combustion chamber. Standard lumped parameter modelling methods are used to represent the system dynamic behavior, figure 12. Additionally, the feed system model is augmented by a structural model of a typical turbine blade (presumed to be a critical component). The blade is represented as a three lump mass, with six degrees of freedom at each lump, (i.e., an 18 D.O.F. model). The load on the blade consists of two parts, the first is $(1/n)$ th of the drive torque as inferred by the performance equations, where n is the number of turbine blades, and the second part is a dynamic term which represents the oscillatory load of the blade passing each stator. Fatigue at the blade root is used as blade damage indicator. The damage model of equation 6 is used in the results that follow.

The general approach for this study is to use non-linear programming to determine optimum (life extending) valve position sequences to vary the thrust (throttle) of the rocket engine. Then a control could be designed to emulate these responses. A future option is to select an appropriate control structure and to use non-linear programming to determine the best gain selection with both dynamic response and component life in a quadratic performance measure J . The performance measure used in this study is quadratic and is given by:

$$J = \sum_{k=0}^{N-1} (Z_k^T Q Z_k + U_k^T R_k U_k + W(O_J H_2)^2) \quad \text{where } Z_k = [x_k^T \ v_k^T]^T \quad (8)$$

here X is the plant state vector, U the control input vector and v the damage state vector. For the following results the state variables are: Turbine shaft speed, Pump mass flow rate, Preburner gas pressure, Preburner gas density, combuster gas pressure, combuster gas density. The oxygen to hydrogen mass flow ratio was brought into the

optimization to directly maintain the O_2/H_2 specification through the transient. The control inputs are O_2 Valve #1 position and O_2 Valve #2 position. Various constraints have been applied and are indicated in the case discussed.

In the case that follows the programming weightings for equation 8 are as follows:

Chamber Pressure: $Q_5 = 12$
 All other Q_i : $Q_i = 1$
 O_2/H_2 : $W = 10$
 Damage Weights (on v) = 0

The rocket engine is initiated from a equilibrium condition at 2700 PSI chamber pressure and a 6.02 oxygen/hydrogen ratio. From this condition the optimization is asked to set a new steady-state point at 3000 PSI at the same ratio. The errors to be minimized, then are based on the deviations from the 3000 PSI condition and the standard O_2/H_2 ratio. Two cases then are studied in the optimization. These are 1.) the unconstrained case and 2.) the constrained case in which damage rate is constrained by the following equation.

$$\begin{aligned} t = 0 \text{ to } 2 \text{ ms} & \quad D \leq 1.0 \times 10^{-6} \\ t = 2 \text{ to } 3 \text{ ms} & \quad D \leq 1.5 \times 10^{-6} \\ t = 4 \text{ to } 50 \text{ ms} & \quad D \leq 3. \times 10^{-5} \end{aligned}$$

The charts of Figure 13a - 13d examine the various engine parameters under these two sets of conditions. Figure 13a shows the valve areas for the two oxygen valves resulting from the optimization over 50 millisecond time frame for the two cases.

Associated with each of the two valve areas in figure 13a are the corresponding oxygen flows into the main combustor and into the preburner. The flows are seen to follow the valve positions in general form closely, as would be expected.

Figure 13b looks at the effects of these flows through the system dynamics of the preburner. The preburner pressures and temperatures that result are shown in the left two sub-figures of 13b. The preburner pressure and temperature and the turbine back pressure (not shown) generate the turbine torque which is indicated in figure 13b. Turbine torque sets the stress on the turbine blades and is plotted in the lower right hand figure. This stress is one of the basic inputs to the damage calculation.

Figure 13c shows the major rocket engine parameters. The hydrogen and oxygen flow to the main chamber are plotted at the top of the figure and their impact on the main rocket chamber operating parameters of oxygen to hydrogen ratio and combustor pressure are shown in the lower quadrants. The combustor pressure is seen to rise smoothly in the two cases with a small perturbation occurring at about 2 1/2 milliseconds. The two plots are seen to be quite similar in overall response and in fact the net excursion of oxygen/hydrogen ratio is seen to be in the vicinity of about 6.5 in both cases for the up-thrust transient for the rocket engine. This 6.5 mixture ratio is about the limit that would be tolerated during a transient excursion.

The final plate, figure 13d, compares the damage rate and the accumulated damage for the two cases. The damage rate is plotted in both a logarithmic scale since it varies over about ten orders of magnitude and also on a linear scale to assist the reader. The accumulated damage in the logarithmic scale shows a significant difference between the constrained case and the unconstrained case. The constraint on damage rate can be seen in the damage rate plots as the long dash line. This is the constraint which is applied during the optimization and below it one can see the actual damage rate that occurred. The damage rate of course is being modified by the manner in which the valves are sequenced and the flow to the system is changed in response.

The important aspect of course is the accumulated damage. The accumulated damage of the unconstrained case (in the linear form) can be seen to be about four times that of the constrained case. This is a clear message that the consideration of damage in designing the transients to which a rocket is exposed can have a considerable impact on the life of the critical components (in this case, the turbine blades). This study only considers a single point of critical stress namely the turbine blades. Future studies will bring in other areas in the rocket engine that are critical. It will be noted that there is practically no penalty in chamber pressure (thrust) response time between the two cases. If one is willing to pay a small price in response time even larger gains may be possible on the accumulated damage at the critical components.

Summary

This paper has reiterated the broad concept of Life Extending Control and has shown initial steps toward its application for reusable rocket engines. In this study only the fatigue effects on life have been considered. However, the concept of life extending control is expected to have broad application and to be generalized to include the effects of creep, thermal transients, and perhaps even corrosion effects.

The initial formulation of a continuous damage model has been shown. These results have not yet been validated and the details of their derivation will be given in a report being separately published. The preliminary application of this concept applying non-linear programming methods to a simplified rocket engine has shown the ability to manage (open loop) the damage accumulation during throttle transients. The future work remains to generalize this to a control which will effect the same valve motions on an instantaneous feedback basis.

References

1. Lorenzo, Carl F. and Merrill, Walter C.; Life Extending Control - A Concept Paper. June 26-28, 1991, Paper TA1:1080 1991 American Control Conference, Boston, MA, NASA TM 104391.
2. Lorenzo, Carl F. and Merrill, Walter C.; Life Extending Control - An Interdisciplinary Engineering Thrust - May 14-15, 1991, NASA-Structural Durability Conference - LeRC - Cleveland, Ohio.
3. Lorenzo, Carl F. and Merrill, Walter C.; Life Extending Control, May 15-17, 1990 - 1990 Conference on Advanced Earth-to-Orbit Propulsion Technology- held at NASA George C. Marshall Space Flight Center, Marshall Space Flight Center, Alabama, May 15-17, 1990.
4. Dowling, N. E., Brose, W. R., and Wilson, W. K.; Notched Member Fatigue Life Predictions by the Local Strain Approach, in Fatigue Under Complex Loading: Analyses and Experiments, Library of Congress CCN 77-85454, Society of Automotive Engineers, Inc. 1977.
5. Saltsman, J. F. and Halford, G. R.; Life Prediction of Thermomechanical Fatigue Using A Total Strain Version of Strainrange Partitioning (SRP) - A Proposal. NASA TP-2779, February 1988.
6. Ray, Asok, Wu, MinKuang, Carpino, Marc, Lorenzo, Carl F., and Merrill, Walter C.; Damage-Mitigating Control of Aerospace Systems for High Performance and Extended life, June 24-26, 1992, 1992 American Control Conference, Chicago, Illinois.
7. Ray, A., Wu, M. K., Carpino, M. and Lorenzo, C. F. ; Fatigue Damage Control of Aerospace Systems for High Performance and Extended Life. To be presented - ASME Winter Annual Meeting November 1992, Anaheim, California

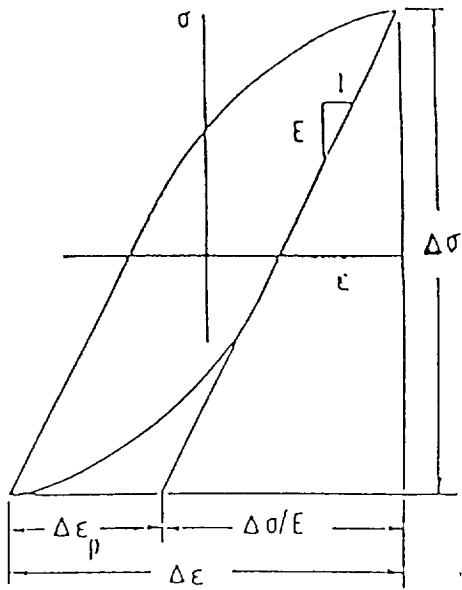

Figure 1. Stress-Strain Hysteresis Loop

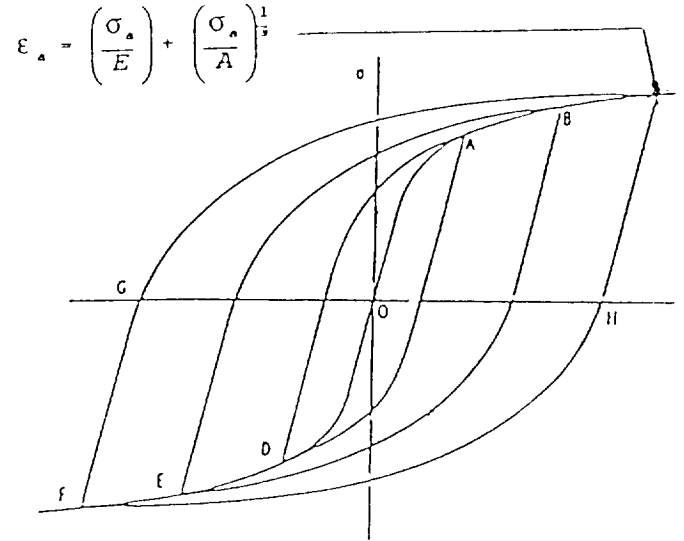

Figure 2. Typical Stress-Strain Amplitude Effects

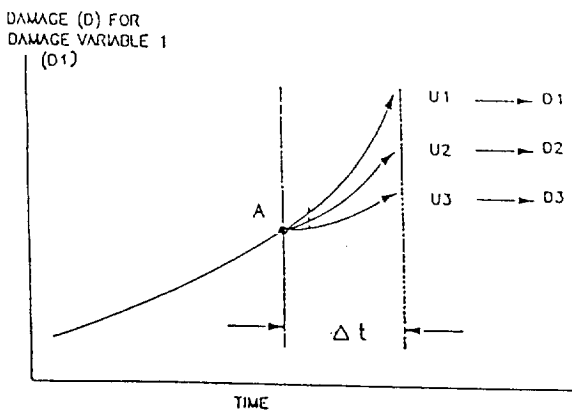

Figure 3. Incremental Damage Resulting From Control Actions

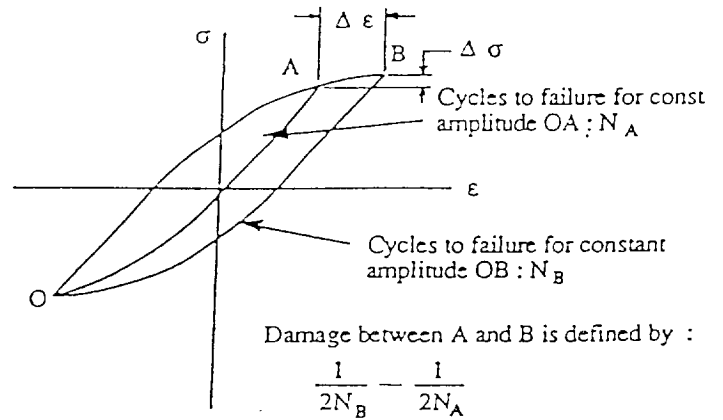

Figure 4. Incremental Hysteresis Cycles As A Basis For The Continuous Life Model

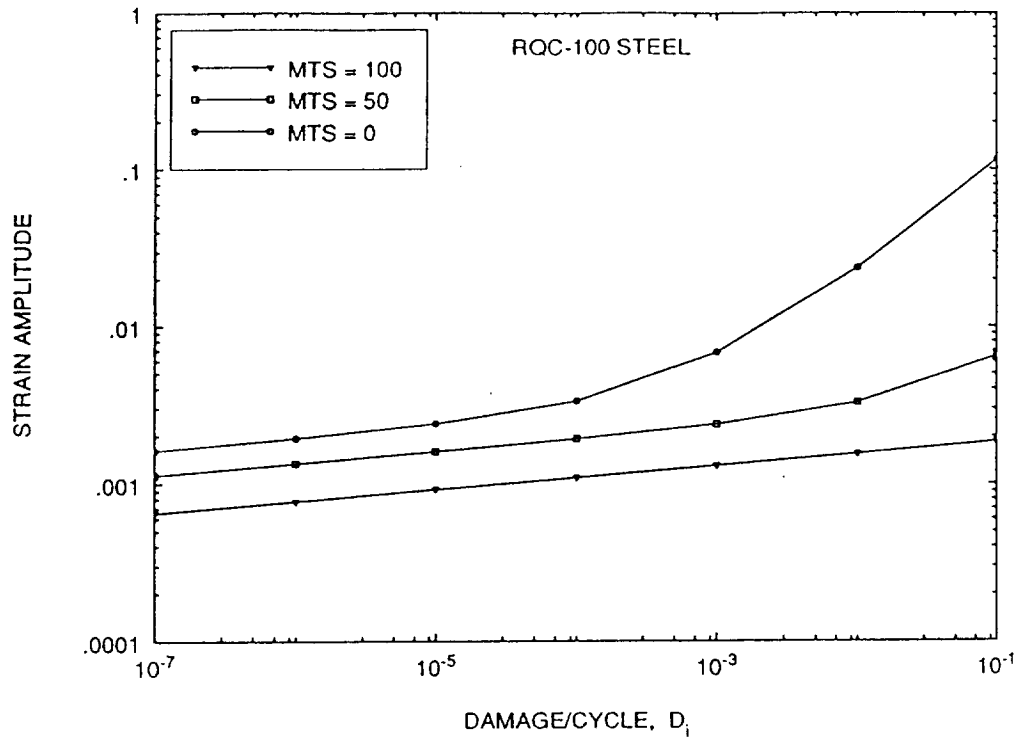

Figure 5. Mean Tensile Stress Effect On Life Usage

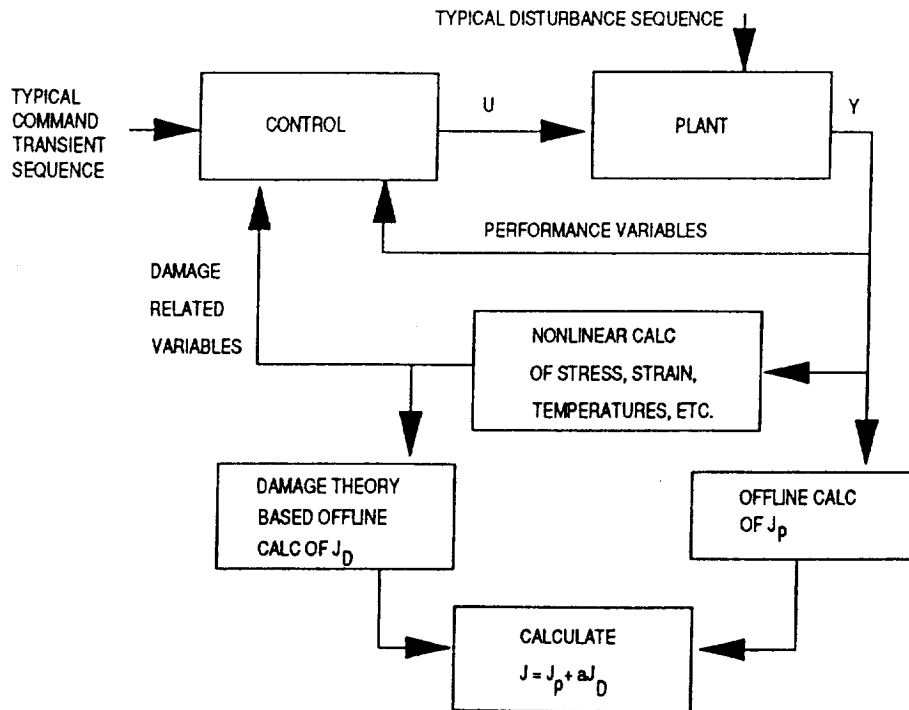

Figure 6. Implicit Life Extending Control Approach

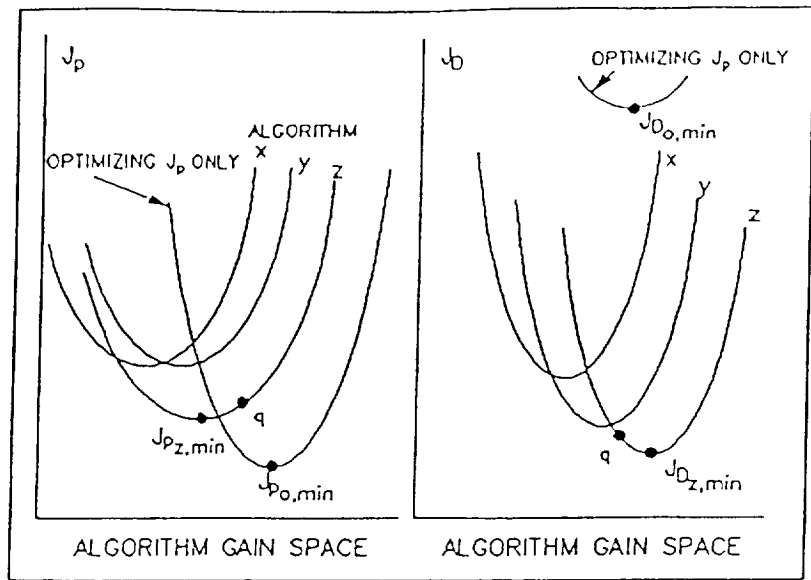

Figure 7. Effect Of Various Life Extending Control Algorithms On Performance (J_p) And Damage (J_d)

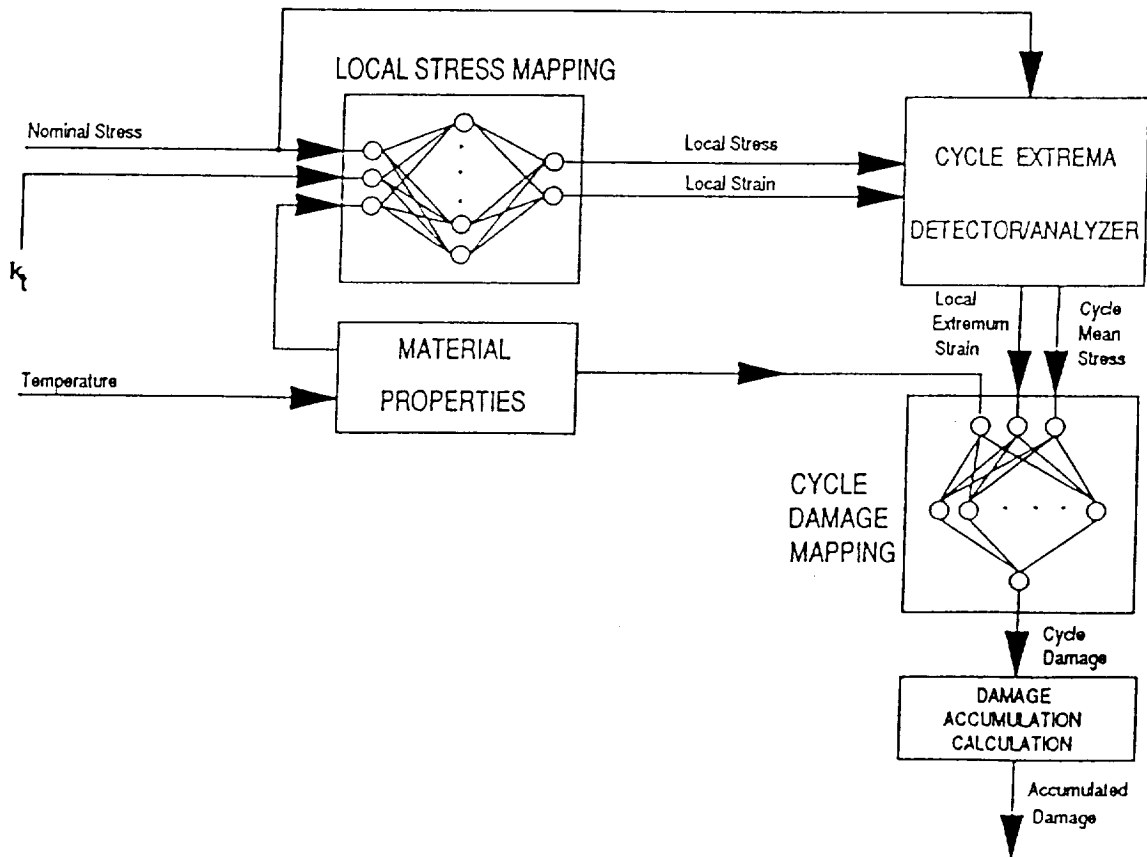

Figure 8. Temperature Sensitive Neural Damage Estimator

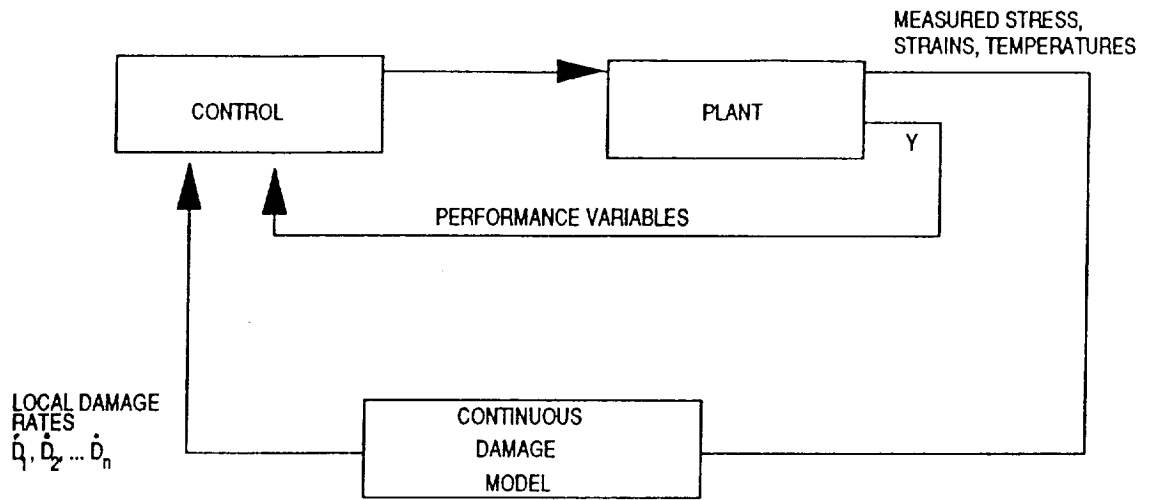

Figure 9. Direct Life Extending Control: Measured Damage Variables Approach

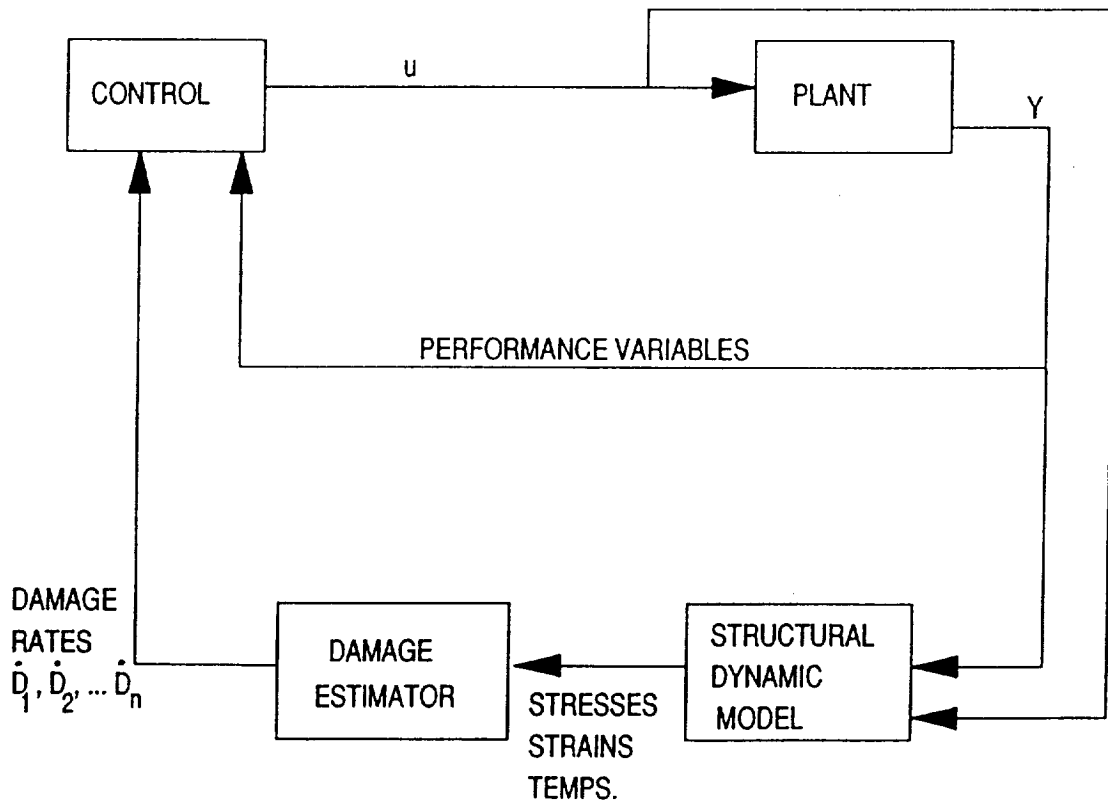

Figure 10. Direct Life Extending Control: Estimated Damage Variables Approach

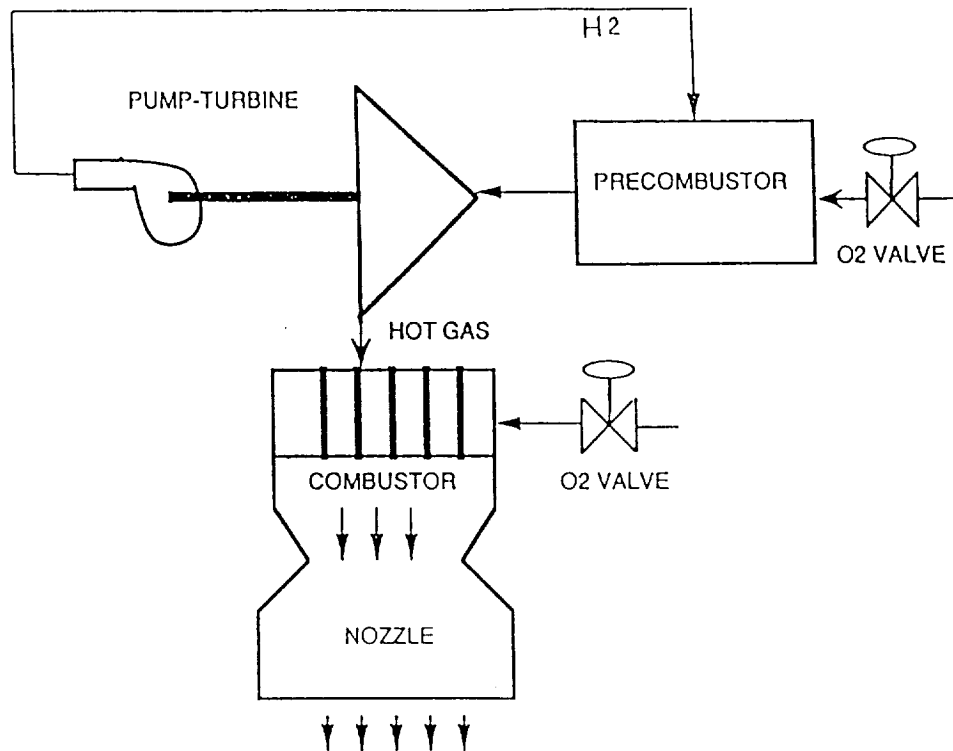

Figure 11. A Simplified Rocket Engine Schematic

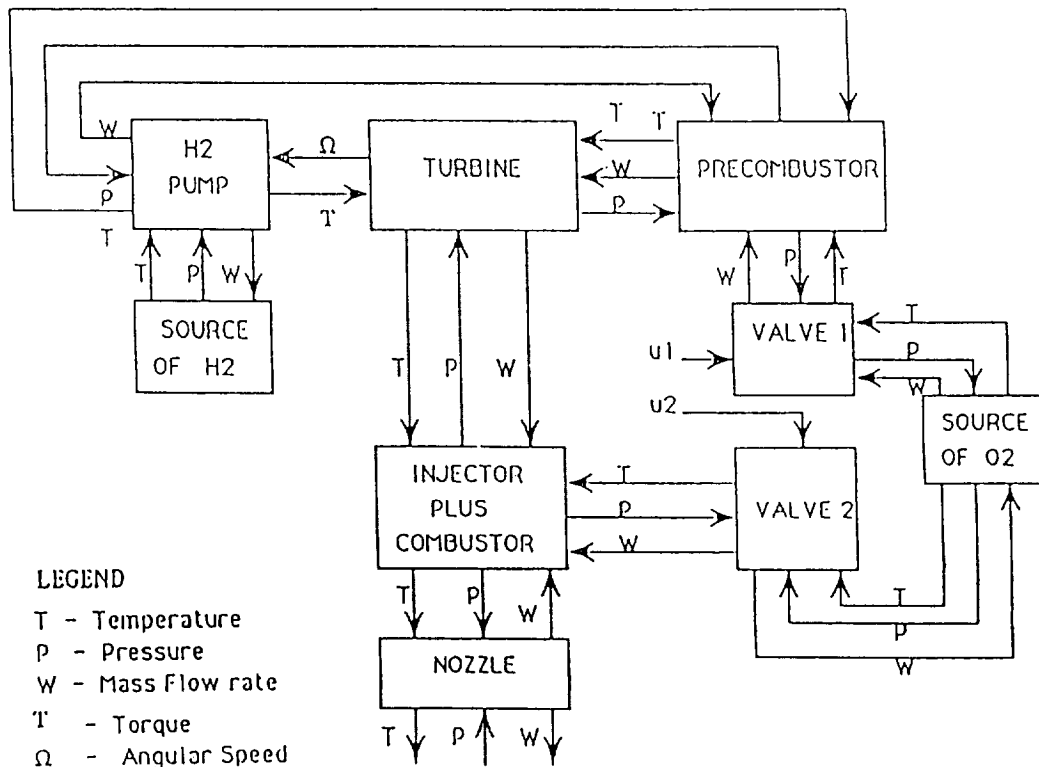

Figure 12. A Simplified Rocket Engine Dynamic Model Block Diagram

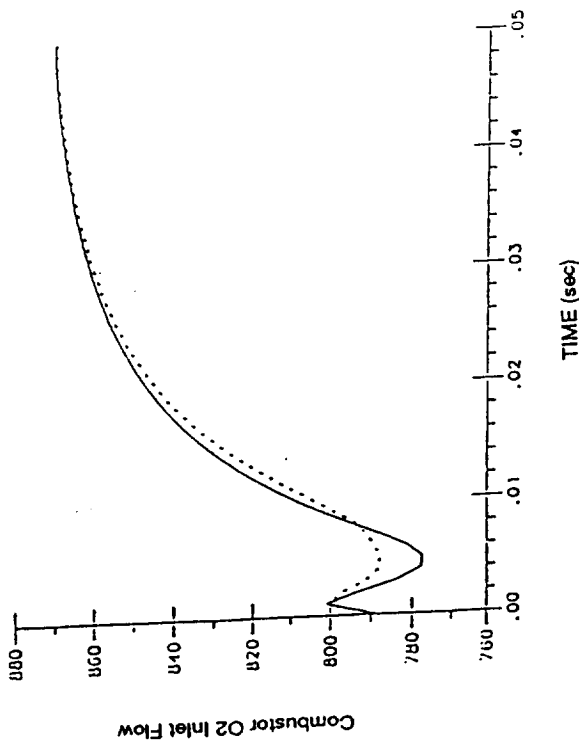
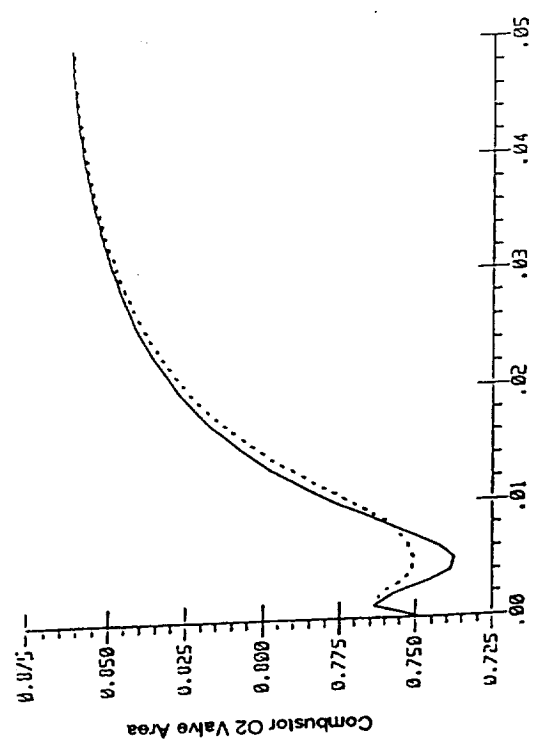
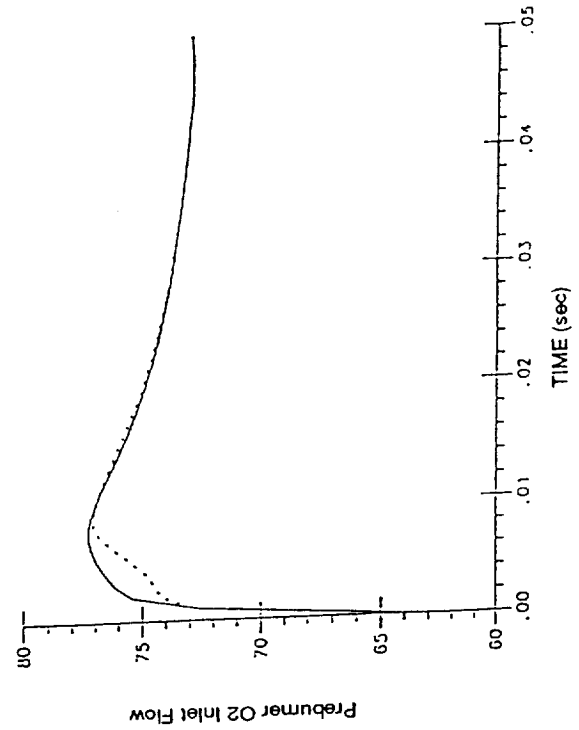
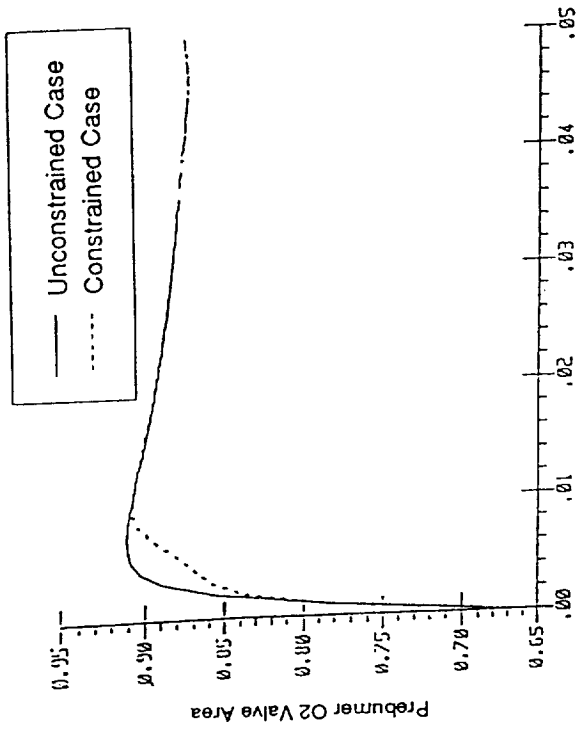

Figure 13a. Rocket Engine Optimal Responses With And Without Damage Constraints: Valves And Flows

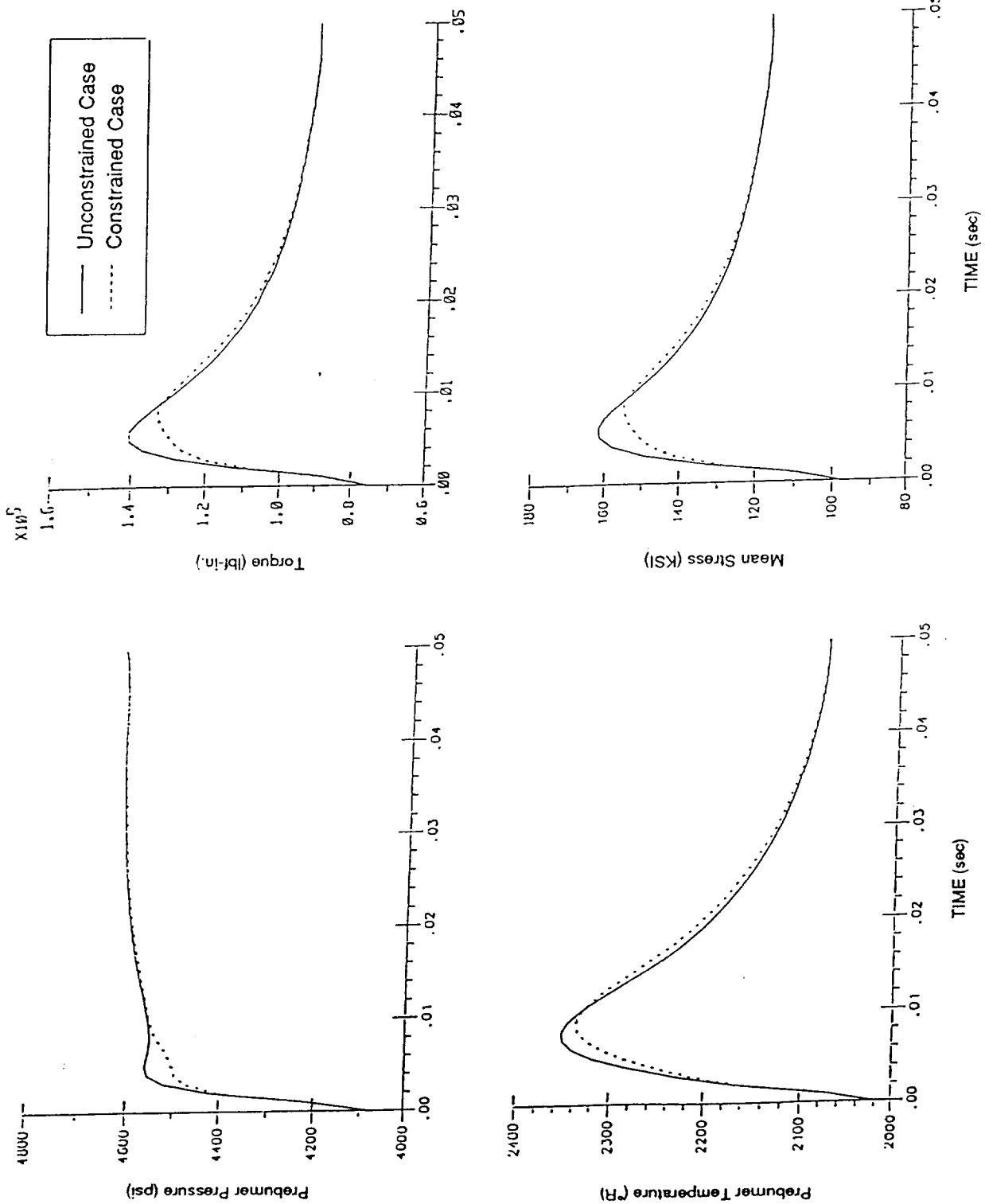

Figure 13b. Rocket Engine Optimal Responses With And Without Damage Constraints: Preburner And Turbine

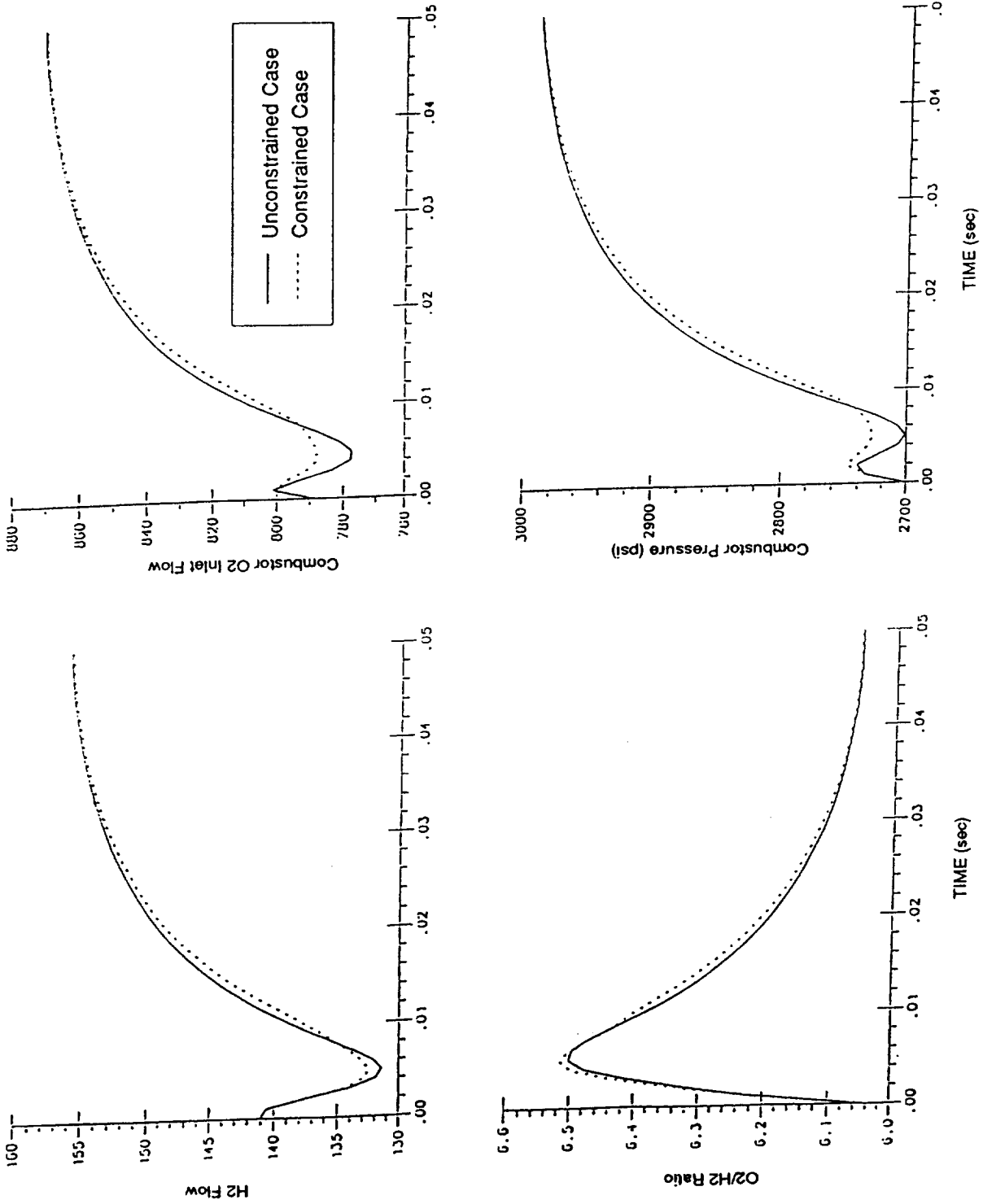

Figure 13c. Rocket Engine Optimal Responses With And Without Damage Constraints: Chamber Pressure And Mixture Ratio

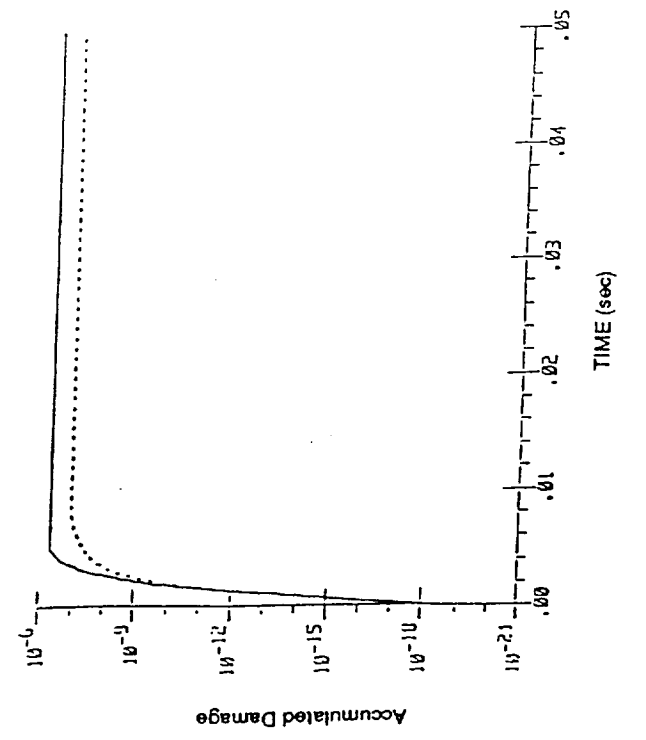
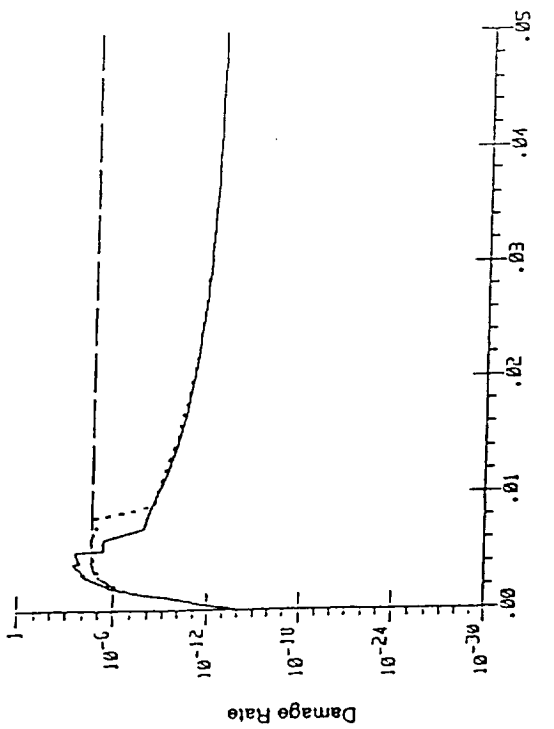
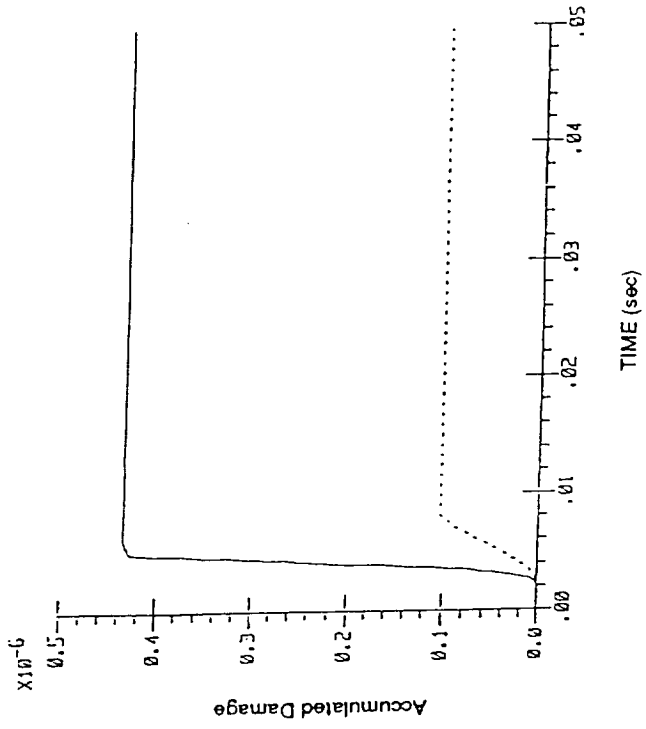
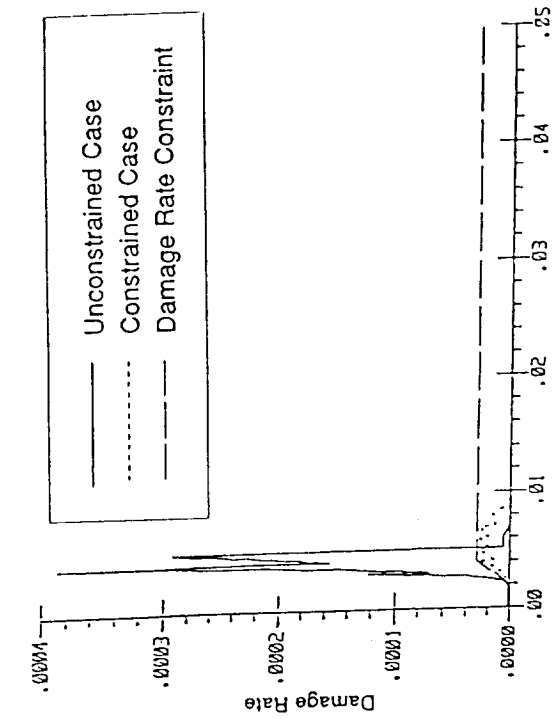

Figure 13d. Rocket Engine Optimal Responses With And Without Damage Constraints: Damage Rates And Accumulation

REPORT DOCUMENTATION PAGE

Form Approved
OMB No. 0704-0188

Public reporting burden for this collection of information is estimated to average 1 hour per response, including the time for reviewing instructions, searching existing data sources, gathering and maintaining the data needed, and completing and reviewing the collection of information. Send comments regarding this burden estimate or any other aspect of this collection of information, including suggestions for reducing this burden, to Washington Headquarters Services, Directorate for Information Operations and Reports, 1215 Jefferson Davis Highway, Suite 1204, Arlington, VA 22202-4302, and to the Office of Management and Budget, Paperwork Reduction Project (0704-0188), Washington, DC 20503

1. AGENCY USE ONLY (Leave blank)	2. REPORT DATE August 1992	3. REPORT TYPE AND DATES COVERED Technical Memorandum	
4. TITLE AND SUBTITLE Life Extending Control for Rocket Engines		5. FUNDING NUMBERS WU-590-21-11	
6. AUTHOR(S) C.F. Lorenzo, J.R. Saus, A. Ray, M. Carpino, and M.-K. Wu			
7. PERFORMING ORGANIZATION NAME(S) AND ADDRESS(ES) National Aeronautics and Space Administration Lewis Research Center Cleveland, Ohio 44135-3191		8. PERFORMING ORGANIZATION REPORT NUMBER E-7219	
9. SPONSORING/MONITORING AGENCY NAMES(S) AND ADDRESS(ES) National Aeronautics and Space Administration Washington, D.C. 20546-0001		10. SPONSORING/MONITORING AGENCY REPORT NUMBER NASA TM-105789	
11. SUPPLEMENTARY NOTES C.F. Lorenzo and J.R. Saus, NASA Lewis Research Center, Cleveland, Ohio. A. Ray, M. Carpino, and M.-K Wu, Penn State University, University Park, Pennsylvania 16802. Responsible person, C.F. Lorenzo, (216) 433-3733.			
12a. DISTRIBUTION/AVAILABILITY STATEMENT Unclassified - Unlimited Subject Categories 26, 31, 37, and 39		12b. DISTRIBUTION CODE	
13. ABSTRACT (Maximum 200 words) The concept of Life Extending Control is defined. A brief discussion of current fatigue life prediction methods is given and the need for an alternative life prediction model based on a continuous functional relationship is established. Two approaches to life extending control are considered: The Implicit Approach uses cyclic fatigue life prediction as a basis for control design. A second approach called the Continuous Life Prediction Approach which requires a continuous damage law is also discussed. Progress on an initial formulation of a continuous (in time) fatigue model is presented. Finally, non-linear programming is used to develop initial results for life extension for a simplified rocket engine (model).			
14. SUBJECT TERMS Control damage; Fatigue; Rocket engine; Life extension		15. NUMBER OF PAGES 18	
		16. PRICE CODE A03	
17. SECURITY CLASSIFICATION OF REPORT Unclassified	18. SECURITY CLASSIFICATION OF THIS PAGE Unclassified	19. SECURITY CLASSIFICATION OF ABSTRACT Unclassified	20. LIMITATION OF ABSTRACT