

NASA Technical Memorandum 105778

126 267

p-17

Data Distribution Satellite

Grady H. Stevens
Lewis Research Center
Cleveland, Ohio

Prepared for the
International Space Year Conference on Earth and Space Science
Information Systems
sponsored by the California Institute of Technology
Pasadena, California, February 10-13, 1992

(NASA-TM-105778) DATA DISTRIBUTION
SATELLITE (NASA) 17 p

N93-12481

Unclas



G3/32 0126267



DATA DISTRIBUTION SATELLITE

Grady H. Stevens
Lewis Research Center
2100 Brookpark Road, Cleveland OH 44135

Abstract

The Data Distribution Satellite (DDS), operating in conjunction with the planned space network, the National Research and Education Network and its commercial derivatives, would play a key role in networking the emerging supercomputing facilities, national archives, academic, industrial, and government institutions. Centrally located over the US in geostationary orbit, DDS would carry sophisticated on-board switching and make use of advanced antennas to provide an array of special services.

Institutions needing continuous high data rate service would be networked together by use of a microwave switching matrix and electronically steered hopping beams. Simultaneously, DDS would use other beams and on board processing to interconnect other institutions with lesser, low rate, intermittent needs. Dedicated links to White Sands and other facilities would enable direct access to space payloads and sensor data. Intersatellite links to a 2nd generation ATDRS, called Advanced Space Data Acquisition and Communications System (ASDACS), would eliminate one satellite hop and enhance controllability of experimental payloads by reducing path delay. Similarly, direct access would be available to the supercomputing facilities and national data archives. Economies with DDS would be derived from its ability to switch high rate facilities amongst users as needed. At the same time, having a CONUS view, DDS could interconnect with any institution regardless of how remote. Whether one needed high rate service or low rate service would be immaterial. With the capability to assign resources on demand, DDS will need only carry a portion of the resources needed if dedicated facilities were used. Efficiently switching resources to users as needed, DDS would become a very feasible spacecraft, even though it would tie together the space network, the terrestrial network, remote sites, 1000's of small users, and those few who need very large data links intermittently.

Space Science 2010

By 2010 it is expected that Space Station will be a mature platform (Figure 1), serving as a large scale science laboratory as well as a possible way station for interplanetary and lunar missions. STS may have a successor in development by then, but in any case, there will be frequent resupply rendezvous with SS. Mission to planet earth will be peaking in activity with a variety of science missions orbiting the earth. Studies will be underway for the replacement for the aging ATDRS fleet called the Advanced Space Data Acquisition and Communications Satellite (ASDACS).

Terrestrially, NREN will have transitioned and become a mature commercial network tying together the nation's supercomputing resources and major research centers. National archives will routinely distribute high resolution imagery and other data electronically. Scientists will collaborate on research by means of multimedia aids, communicating effortlessly though they may be thousands of miles apart.

The first phase of DDS, DDS I, will be in place providing access to the space network and the nation's science facilities for many institutions that would otherwise be too remote for economical access. In some ways DDS would act as a bridge between the space network and terrestrial networks. In others, DDS would itself serve as the hub for specialized nets.

DDS, a National Science Communications Hub

For the US, DDS could be accessed by a variety of earth stations ranging from 1.8 meter to 7 meters (Figure 2). Major science centers with very high data rate needs would use the larger terminals. Peer collaboration, archive access, and medium scale computer communications could be achieved with the smaller terminals which would have a maximum capability of 1.5 Mbps. The 5-7 meter antennas would be more permanent, but the smaller terminals could be located on rooftops and could be relocated to other locations as needed. No matter how remote an institution might be, access to DDS could be obtained the same day as delivery of the small earth stations.

DDS, also a Space Science Communications Hub

The later phase of DDS, DDS II, would carry equipment for linking to other platforms in geostationary orbit (Figure 3). Primary attention would be given to relaying transmissions from the ASDACS, but DDS would also be capable of relaying transmissions from NASA, European, and Japanese platforms. Service could be scheduled in advance, as now done with TDRSS, or provided on request by means of microwave orderwires. With sufficient redundancy (probably an on-orbit spare DDS), DDS might have a role in closing the ZOE of ASDACS. Locating separate spacecraft at 80°W and 120°W provides a very favorable elevation into the eastern and western US (important for reducing rain attenuation to be discussed later). The pair, as a system, would also

have all planned geostationary platforms in view.

Estimated Science Communication Needs

LORAL and Stanford Telecommunications, each under NASA sponsorship, have provided estimates of the communication needs for space science through 2010 (Figure 4). The method made use of NASA and other planning documents which focused on space station as well as the Mission to Planet Earth. In addition extrapolations were made from known trends of selected institutions.

A key effort in this activity was the attempt to remove the influence of ATDRS restrictions on determining actual need. Obviously experimenters must design their experiments to be accommodated by TDRSS/ATDRS capability. There simply will not be any other alternative, at least until ASDACS. Consequently, the available planning documents will reflect data needs that, not surprisingly, just match TDRSS/ATDRS capability. The challenge is to make use of interviews, assess sensor technology, and "read between the lines" to ferret out the "real" needs.

LORAL attempted such a process and their estimates included the three subdivisions of telescience, peer networking, and other.

Telescience refers to a concept of using multimedia communications to enable remote researchers to interact with nearly the same freedom as being in a common facility. It would include collaboration, of course, but it also includes remote access and operation of experiments. The intent is to use multimedia facilities to remove the barriers of distance. Peer networking can be an element of telescience, but it refers more to the traditional forms of communications among researchers of a common discipline: voice, fax, mail and data exchange. LORAL's "other" category includes international communications with cooperating institutions in Europe, Japan, etc.

LORAL's estimates indicates telescience and peer networking could generate 5 Gbps each by 2007 and each could double by 2010. International communications could amount to 1 Gbps by 2007 growing to 2 Gbps by 2010. The total expected need would be 11 Gbps by 2007 growing to 22 Gbps by 2010. Of course any 18 year forecast would have a great deal of uncertainty associated with it. And recognizing this forecast is no different, LORAL provided uncertainty bounds of 2-25 Gbps for 2007 and 5-40 Gbps for 2010.

Data Potential Exceeds Spectrum Available

It is expected that the bulk of this data would be transferred by emissions in certain microwave bands (Figure 5), which will be subject to national and international regulatory bodies as to their use. Ku-band (10.7-13.25 and 13.25-15.4 GHz) and Ka-band (17.3-21.4 and 27.5-31.3 GHz) are the most likely bands to be used for DDS, as the lower frequency bands are filled with commercial services and higher frequency bands would suffer severe rain attenuation. Not all of these bands would be available as portions of each are already allocated for other services. Only 0.5 GHz would be available at each of Ku and Ka-band on a non-sharing basis. Possibly more spectrum could be obtained at Ka-band as long as care was taken to avoid interference with other services and vice versa. Even so, the Ka-band allocation would not likely exceed 1.0 GHz.

Standard modulation methods in space systems achieve about 1 bit/Hz spectrum efficiency. Consequently, the spectrum requirements for the data estimates by LORAL far exceed the spectrum available (11 GHz vs. 1-1.5 GHz in 2007). It will then be necessary to effectively "multiply" the available spectrum by using multiple satellites, or multibeam antennas which reuse the same spectrum several fold, or advanced modulation/coding schemes which achieve multiple bits/Hz spectrum efficiency, or all of the above.

A Little Extra Power and Complexity Can Double Spectrum Efficiency

C. Shannon derived a relation which specifies the maximum error-free capacity of any noisy communications channel. Expressed in the form of maximum achievable spectrum efficiency (Figure 6), this bound exceeds current state of the art by about a factor of four for weak signals ($\approx 4-6$ dB Eb/No) and about two for stronger signals (≈ 20 dB Eb/No). Techniques are known for achieving better than ≈ 5 bits/Hz and this efficiency has been realized in the Codex 2680 telephone modem. However, the processing is currently too complex to consider for channels having 10's or 100's of Mbps data rates. COMSAT is developing a 200 Mbps modem with joint NASA sponsorship which achieves 2 bits/Hz spectrum efficiency. The modem uses an 8-PSK modulator in conjunction with 8/9 coding to gain the extra efficiency (BPSK would be 0.5 and QPSK 1.0) with need for very little extra power over QPSK. Coded Quadrature Amplitude Modulation (QAM) would offer additional benefit as long as the satellite channel is not too nonlinear. The Codex 2680 makes use of such techniques.

Considering the high data rates expected for DDS and the complexity of decoders and demodulators for the higher performance modem methods, we judge that 2-3 bits/Hz would be appropriate for planning purposes.

Frequency Reuse With Multiple Beam Antennas

With suitable hardware one can generate multiple independent beams from a single antenna. However, it is exceedingly difficult to achieve isolation between adjacent beams sufficient for quality communications. Generally, beams have to be separated by 2-3 beam diameters to achieve the necessary isolation. As a consequence, adjacent beams have to be isolated either by frequency, polarization, or both. One can then build up a coverage area by arranging beams either in a rhombic pattern or hexagonal pattern with a distinct portion of spectrum for each beam (Figure 7). This achieves isolation for each beam within a cell (rhombic pattern of four or hexagonal pattern of seven beams). Either basic pattern is then repeated, with assured isolation, until the necessary coverage is achieved. Though simple in principle, one needs to understand that the necessary hardware can be exceedingly complex (and heavy) if more than a total of 30 beams is desired. At any rate, the spectrum is multiplied for every added cell (rhombic or hexagonal pattern).

An additional consequence of this approach is that the antenna size increases with the number of cells (approximately as the square root if the coverage area is two-dimensional). This occurs because one needs to use smaller and smaller beams, for a fixed coverage area, to achieve the necessary spectrum multiplication. Therefore, not only will the beamforming hardware increase in weight and complexity, but the reflector itself will also increase in size and weight.

DDS Makes Use of Several Antenna Coverage Patterns

DDS is conceived as making use of multiple antennas as well as two bands to achieve the necessary 11 Gbps capacity with the Ku and Ka-band spectrum constraints. A rhombic pattern of eight 1.7° beams is used for general coverage at both Ku and Ka-band (Figure 8). Additional patterns of smaller beams are also used, 25 beams @ 0.9° and 70 beams @ 0.5° (Figure 9).

The higher density patterns are not intended for simultaneous coverage but only have capability of 10 or so simultaneous active beams. This is sufficient for the necessary frequency reuse and saves on satellite weight. In addition, these smaller beams are primarily for the very high data rate services, which originate with a few major facilities, and therefore only a few beams would ever be needed at a specific point in time anyway.

Rain Attenuation Can be Severe

Both Ku and Ka-band experience significant attenuation in rain (Figure 10). This will have to be accounted for in setting power margins in the communication links to achieve the desired signal reliability. A typical midwest location would have less than 5 dB attenuation 99.9% of the time at 12 GHz. Consequently, a link with this margin or better would have 99.9% reliability or better. However, attenuation increases with frequency. As a result, for the same 99.9% reliability, one would need better than 7.5 dB of margin at 14 GHz, 14 dB at 20 GHz and 25 dB at 30 GHz.

Link margins can be obtained through oversizing power amplifiers or by oversizing the antennas (with clear sky as the reference). To minimize power requirements on the spacecraft, LORAL recommends inclusion of only 3 dB power margin and obtaining the remainder through oversizing the earth stations. Alternatively, one could use a pair of earth stations, separated by 2-3 Km (site diversity), and take advantage of the independence to circumvent the rain attenuation. Of course, this entails the expense of terrestrial facilities to connect to two sites instead of one.

DDS, a Hub as Well as a Bridge

Incorporating all of the above features into DDS, we have a spacecraft which provides area service with broad beams, specialty high data rate service with a few narrow beams (which hop between locations as needed), and direct service to the space network and other space platforms via intersatellite beams (Figure 11).

The large number of low rate channels are isolated and separated by devices called bulk demodulators or transmultiplexors. Each of these devices can simultaneously isolate and separate 100's of low rate channels, saving considerable mass and power over what one would need with discrete filters and demodulators. The bulk demods can have individual channels with rates as low as 144 Kbps and as much as 1.5 Mbps. Higher rate channels make use of discrete filtering and demodulation. In both cases the data are aggregated into time multiplexed serial streams, which are decoded and then routed through an on-board switch to other beams and channels to the final destination. Control is achieved with a dedicated link to a central site where the state of the spacecraft is monitored, and where the switch control messages are generated in response for requests for service.

Use of Power Must be Orchestrated

Considering expected launch capability in 2007, the usual overheads in mass and power for typical communications spacecraft, and the power sources likely to be available, LORAL judged that about 2800 watts of power would be available for a single DDS payload. It would be easy to exceed this if the full 11 Gbps were concentrated in the most power consuming service. To get

the most utility out of the spacecraft without exceeding this limitation, it is necessary to carefully allocate power among a variety of services and deny any particular service from dominating the spacecraft (central control will assure this will not happen).

One particular example (Figure 12) would allot 2000 watts to Ku-band and 800 watts to Ka-band. At Ku-band this would support 54 links of 52 Mbps, 12 links at 160 Mbps, and 3 links at 320 Mbps. At Ka-band this would support 31 links at 52 Mbps, 10 links at 160 Mbps, and 5 links at 320 Mbps. The total amounts to slightly more than 11 Gbps.

Six Antennas Plus an Optical Crosslink Must be Accommodated

To achieve the necessary coverage and access to other orbiting platforms, the DDS spacecraft would carry six antennas with one (1.7 meter) being a dual frequency receive (Figure 13). A 2.0 meter Ku-band antenna and 2.2 meter Ka-band antenna provide for the smaller downlink beams. A 1.7 meter receives at both Ku and Ka-band simultaneously and provides for the small beam receive function at both bands. The larger antennas are hinged so that each rests against the spacecraft body during launch but deploy to the open position once the spacecraft is on station. Solar panels provide the needed DC power which 5500 watts for the 2007 spacecraft (DDS I) and 7000 watts for the 2015 spacecraft.

DDS Complexity Commands a Big Price

In principle there are at least two ways DDS services could be procured. A dedicated government system would be simpler to procure and would have a slight cost advantage (Figure 14). Government reporting and testing requirements would lead to a more expensive spacecraft, but there would be no need for launch insurance, nor would there be profit. Consequently, the dedicated government system would tend to be less in cost. One particular DDS configuration is estimated to cost \$1,308M in the government dedicated scenario. The corresponding annual cost to the government (to repay the manufacturer) would be about \$163M for 15 years. Accounting for typical inefficiencies in utilizing the spacecraft capability, the monthly charge for the small users would be about \$11,335/Mbps and \$5,667/Mbps for the large users. This would compare with a current figure of about \$7,140 for terrestrial alternatives.

An alternative is to use a shared government/commercial spacecraft. In other words, a commercial entity would procure the spacecraft and lease half of its capacity to the government and sell the other half for commercial applications. The cost to procure the system would be less (\$1,281M vs. \$1,308) but the net annual cost is slightly more due to a slight decrease in available capacity (2.5 Gbps vs 3.2 Gbps in the dedicated case). Consequently, user monthly costs would be \$12,547/Mbps for the small user and \$6,274/Mbps for the large user.

These estimates are very sensitive to the actual system utilization. With a dedicated government system it is expected that service requests would be very intermittent and highly variable during the day. In addition, service demand is expected to be small at first and then grow over the life of the spacecraft. With these considerations it is expected that a dedicated DDS system would have an average utilization of 16%.

With the commercial system, excess capacity could be shared with the commercial users with corresponding credit toward the government lease costs. An equivalent way of determining such reduction in costs is to use a higher utilization. For the commercial/government system we assume 25% utilization.

If one were to determine user costs as a function of utilization (Figure 15), one would find that the small user utilization would have to exceed 40% (not likely) to achieve costs comparable to current 1.5 Mbps monthly costs. For the large users the breakeven utilization is about 20%. In this first concept for DDS, the satellite was not necessarily optimally matched to the expected character of the government data demand. It may be possible to make greater use of hopping beams to attain a better match and reduce expected costs.

Using the ACTS Experimental Spacecraft to Test the Concept

An experiment has been proposed by the Ohio State Computing center which will use high rate satellite channels to network several collaborators with a supercomputing facility at OSC (Figure 16). The concept would use the satellite facility as a "backplane" with several workstations simultaneously accessing the data being generated by a Cray supercomputer. Three parallel channels are required to operate three simultaneous windows in the workstations. The high rate (~800 Mbps) channel would supply data for the visualization window. A 48 Mbps channel would accommodate multimedia collaboration window. Finally, a low rate channel would provide for interaction through a control panel window.

Layered Impediments to DDS

The Gulf War introduced many to the concept of a layered defense. It can be deadly. In an analogous way, DDS is a concept that will have to overcome layered resistance and/or impediments (Figure 17). The most fundamental impediments are technological: capable power systems; large and complex multiple frequency reuse antennas; new launch capabilities; and

advances in spectrum efficient modulation. Perhaps an even more fundamental impediment is one of policy.

It is not clear what organization should be responsible for DDS. Of course it would be a very effective adjunct to the NREN, but could the NREN supporters rally another \$1B for an adjunct? NASA has responsibility for space data acquisition and portions of DDS services fall within this charter. However, a substantial portion of its capability consists of peer networking, a service that more resembles terrestrial commercial networking than space data retrieval. Probably the most effective system is a commercial system with a government lease of a significant portion of its capacity. The remaining capacity would be used for conventional services or, perhaps, introduce new business such as broadband ISDN.

Summary

The Data Distribution Satellite (DDS) is intended to act as a bridge between terrestrial facilities, the space network, and other space platforms. In addition, it will support its own networks, providing competitive services and offering ease of access regardless of how remote users might be. DDS is complex and, consequently, expensive. User charges are very sensitive to the average achieved utilization. In this first concept for DDS, the satellite was not necessarily optimally matched to the expected character of the government data demand. It may be possible to make greater use of hopping beams to attain a better match and reduce expected costs.

REFERENCES

1. Price, Kent M.; Jorasch, Ronald E.; Wiskerchen, Michael J.: "Data Distribution Satellite", Space Systems/LORAL, Palo Alto Ca, NASA CR 187066, Feb. 1991.
2. Bruno, Ronald C.; Weinberg, Aaron: "The Data Distribution Satellite System", Stanford Telecommunications, Reston Va, NASA CR 187172, September 1991.

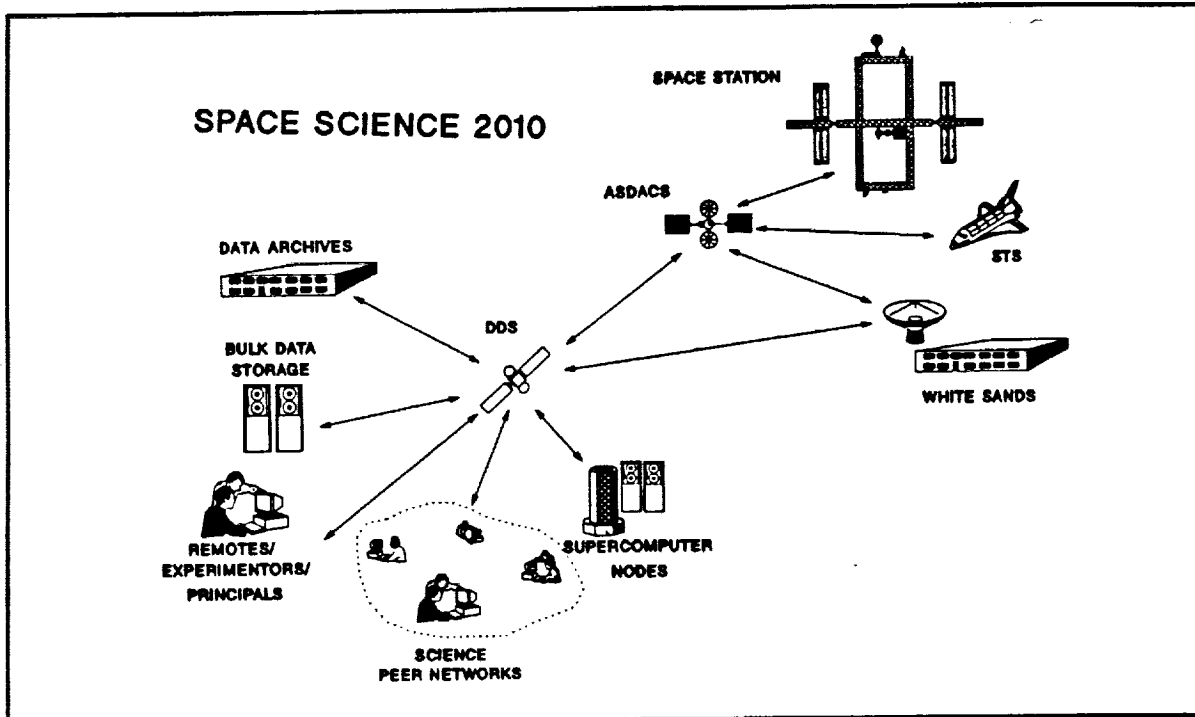

Figure 1 - Space science activities circa 2010 will involve Space Station, STS, ASDACS (or its Successor), Operational NREN, and a number of space science discipline networks.

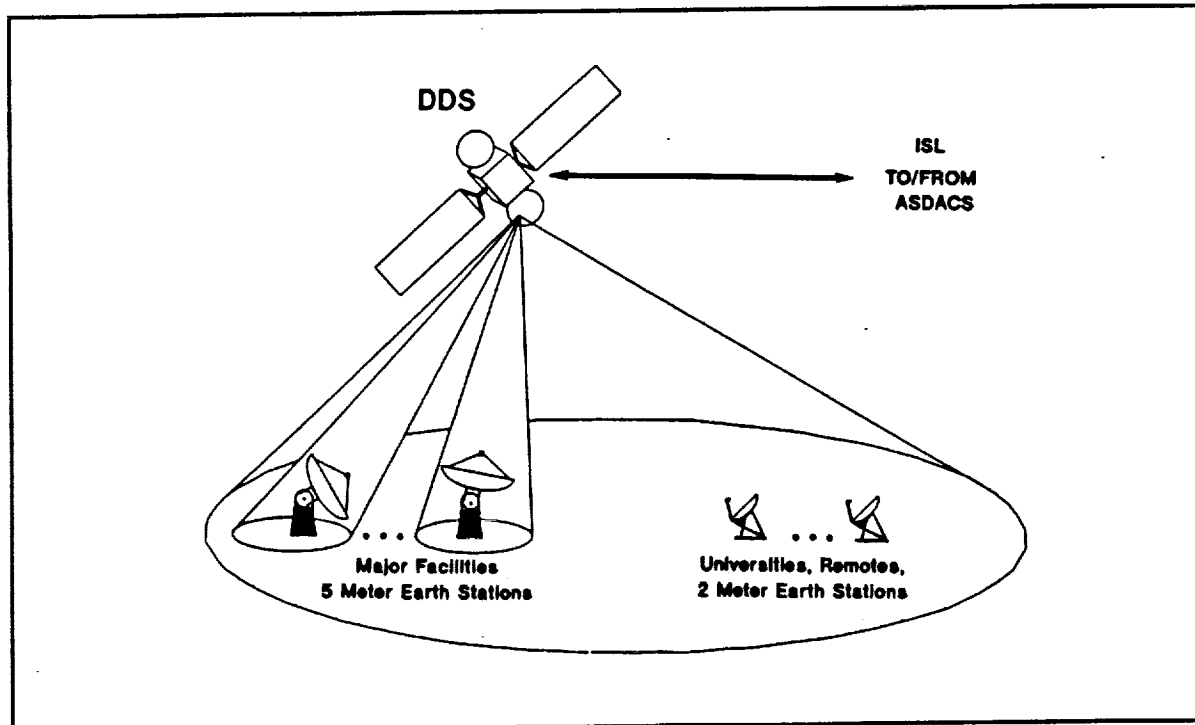

Figure 2 Data Distribution Satellite acts as a national hub, connecting major discipline centers, archives, as well as providing access to universities and remote institutions via small inexpensive earth stations.

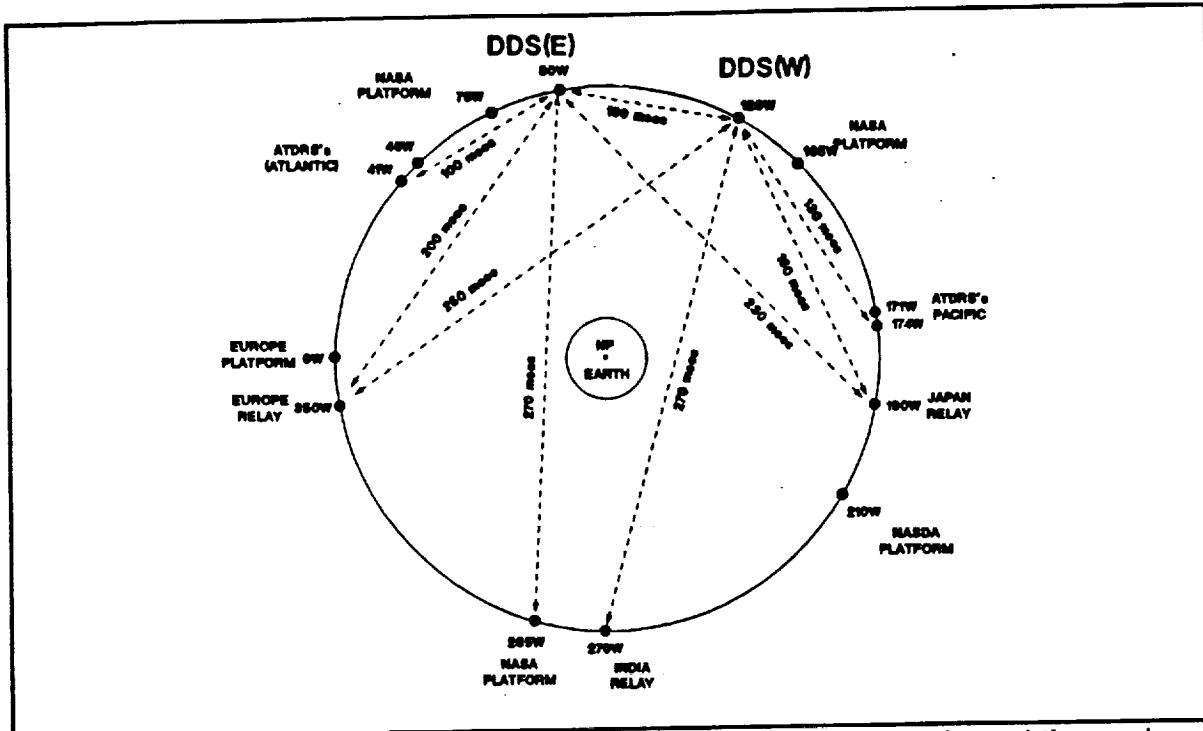

Figure 3 - With a DDS at 80°W and 120°W, constant view is maintained of all planned geostationary platforms and very favorable elevation angles are achieved for accessing earth stations.

**ESTIMATED SCIENCE COMMUNICATION
NEEDS, GBS
(LORAL)**

	2007	2010
Telescience	5	10
Peer Networking	5	10
International, Other	1	2
Totals, Gbs	11	22
Uncertainty, Gbs	2-25	5-40

Figure 4 - Estimates of space science communications data volume and bounds on the uncertainty.

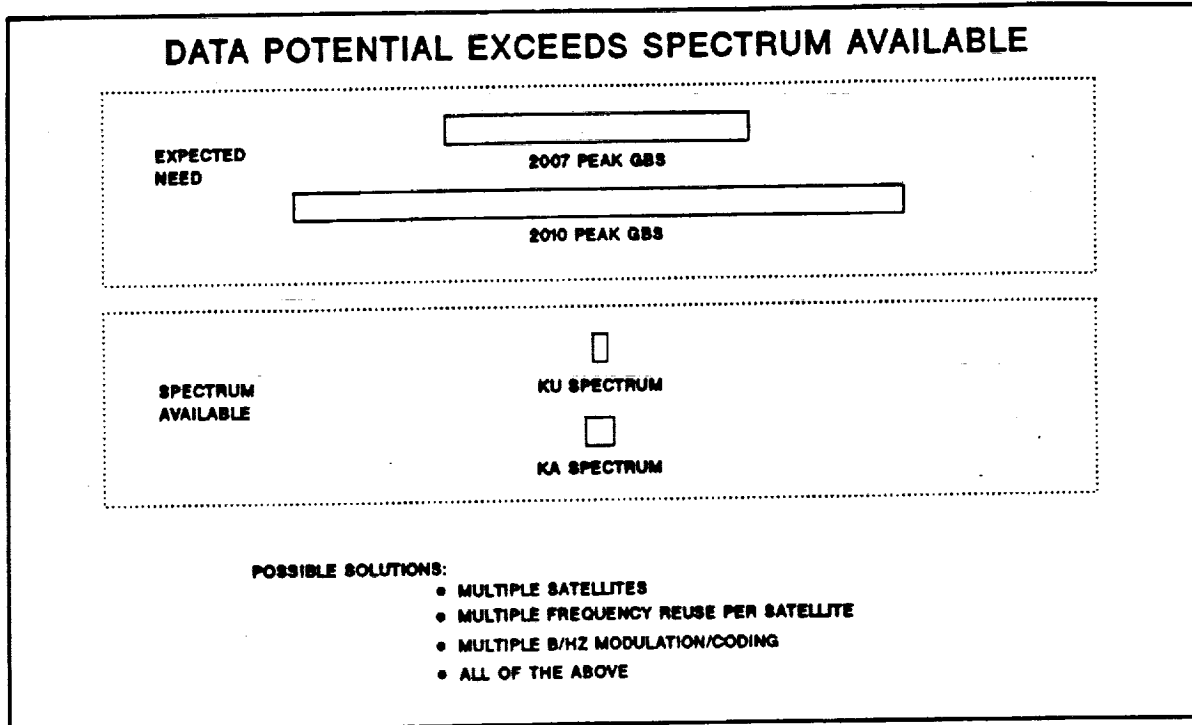

Figure 5 - The estimates of communication volume far exceeds the available spectrum.

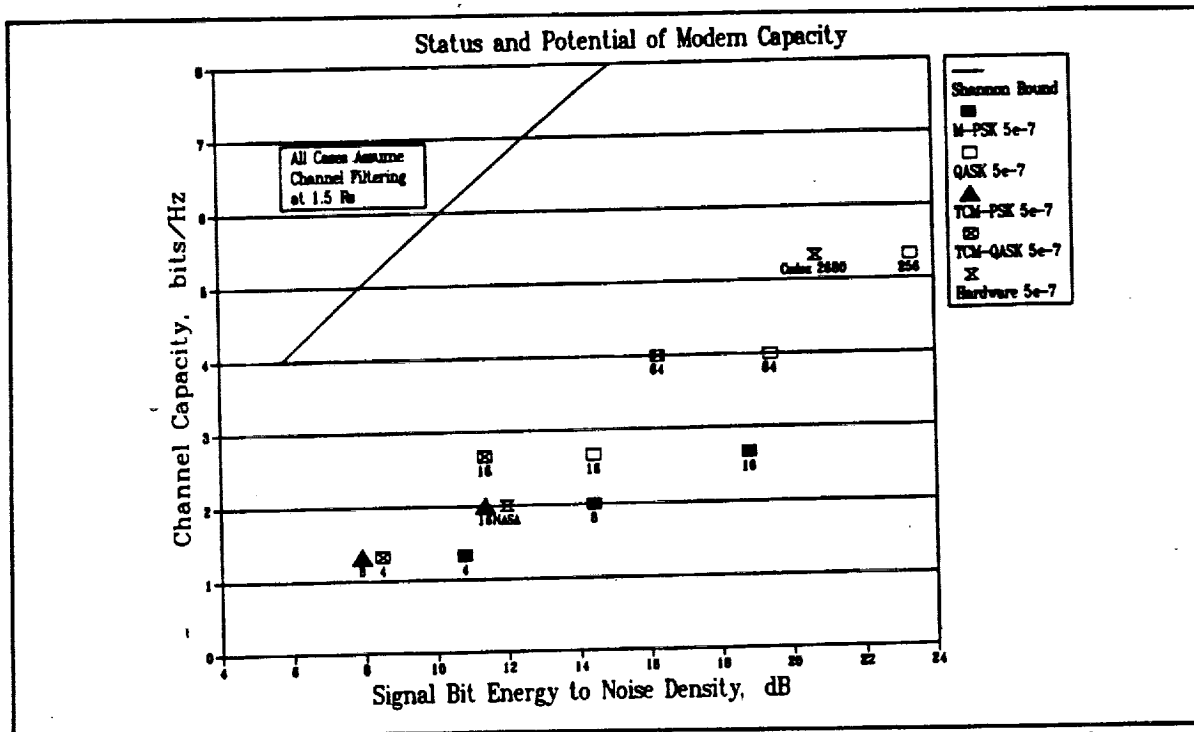

Figure 6 - One way of increasing the effectiveness of available spectrum is to use higher levels of modulation in conjunction with coding.

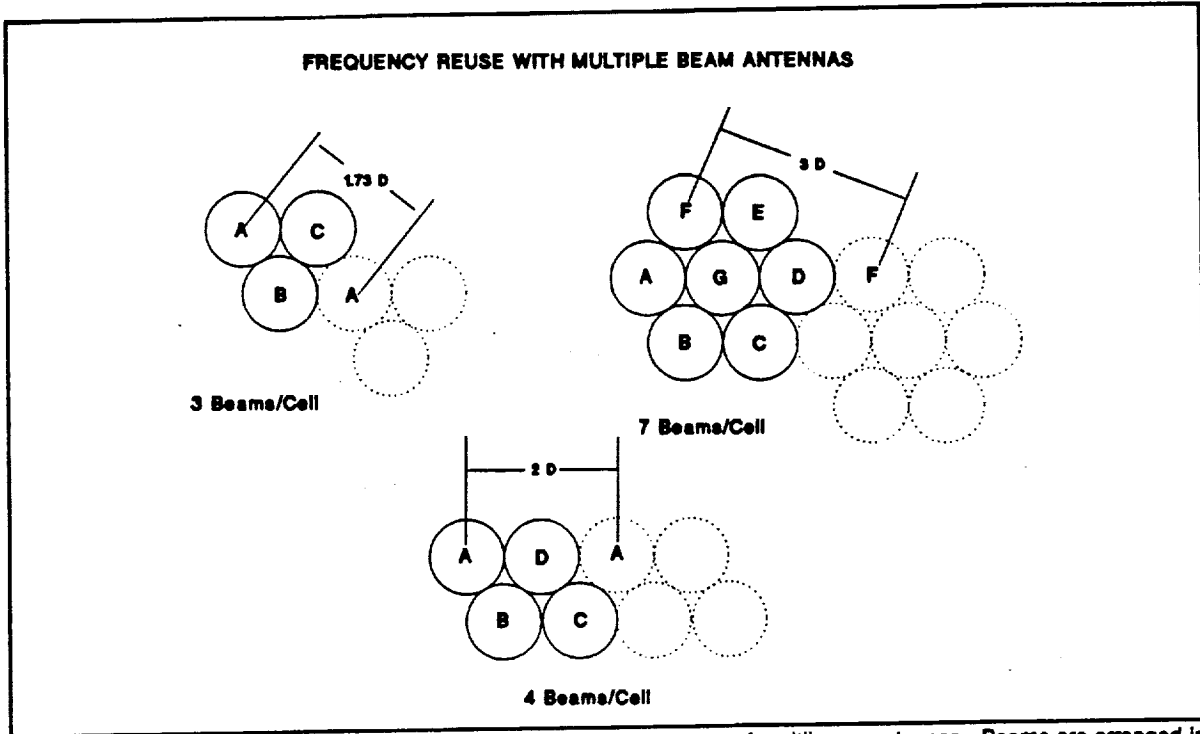

Figure 7 - Another method of increasing utilization of spectrum is the use of multibeam antennas. Beams are arranged in cells of 3, 4, 7, etc. with adjacent beams isolated by frequency separation or by polarization discrimination.

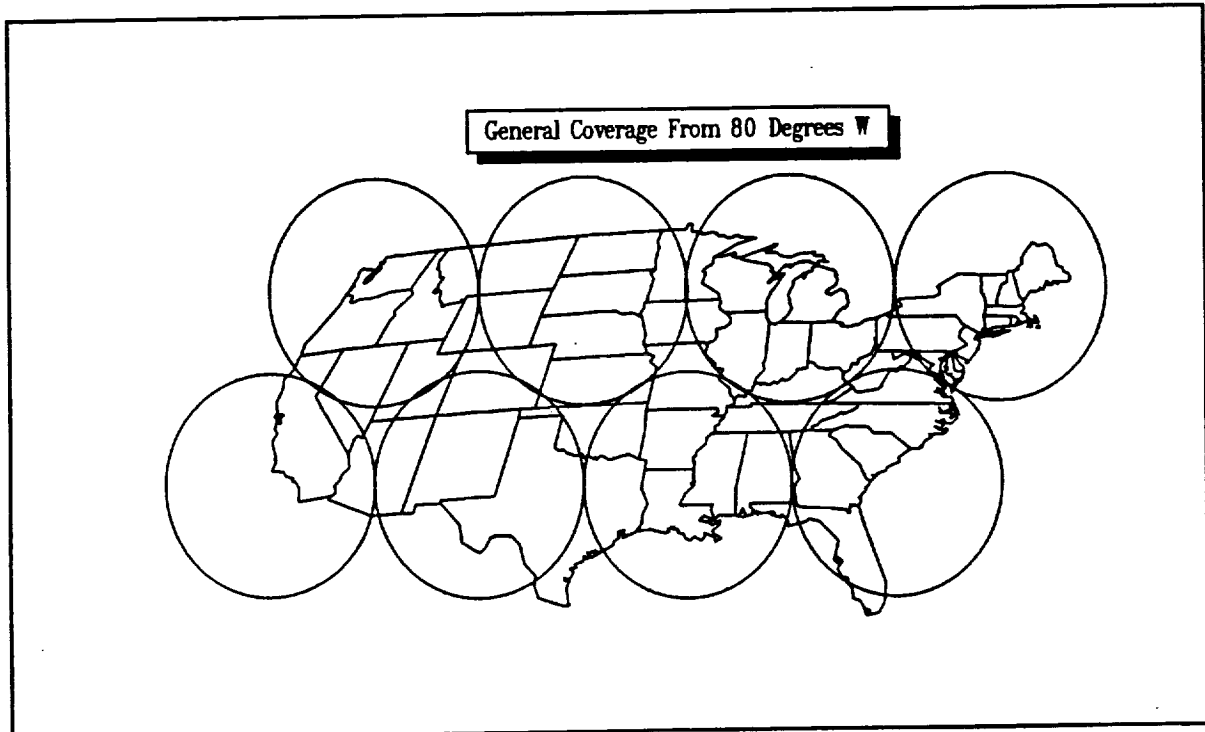

Figure 8 - Coverage of the US from 80°W using the general coverage beams (1.7°).

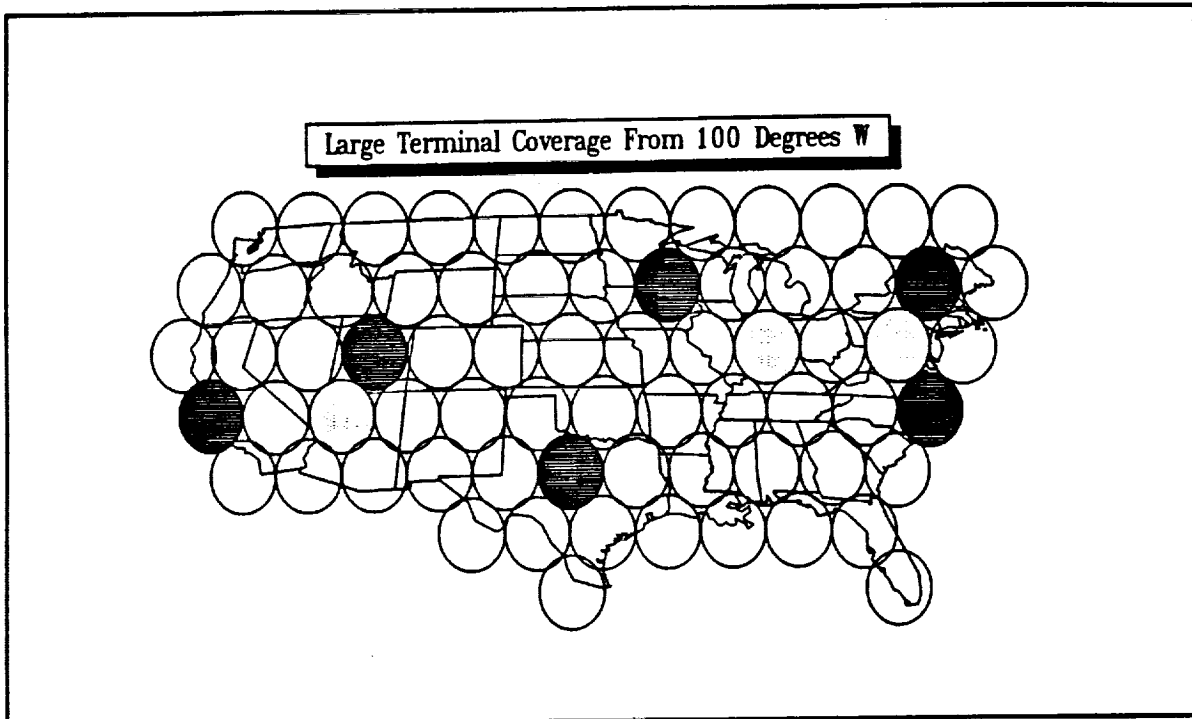

Figure 9 - Coverage of the US from 100°W with 0.5° spot beams. Only a few of the 70 beams are active at any instant of time.

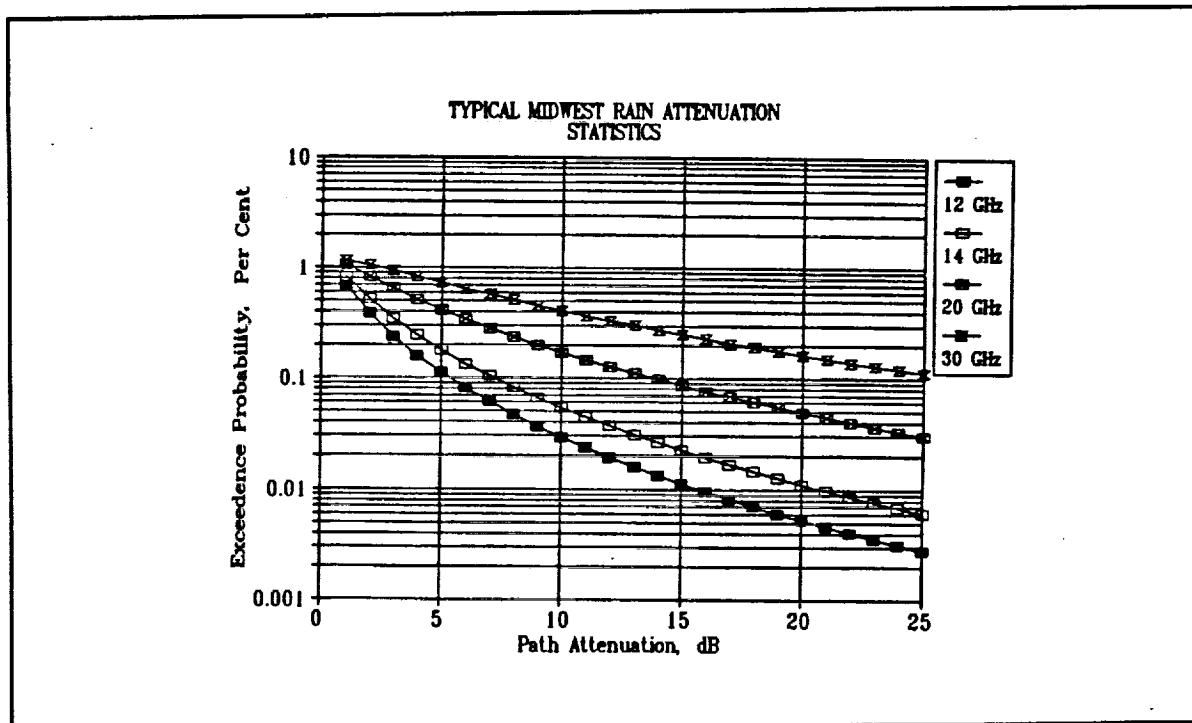

Figure 10 - Though occurring infrequently, Rain attenuation can be very severe, especially at Ka-band.

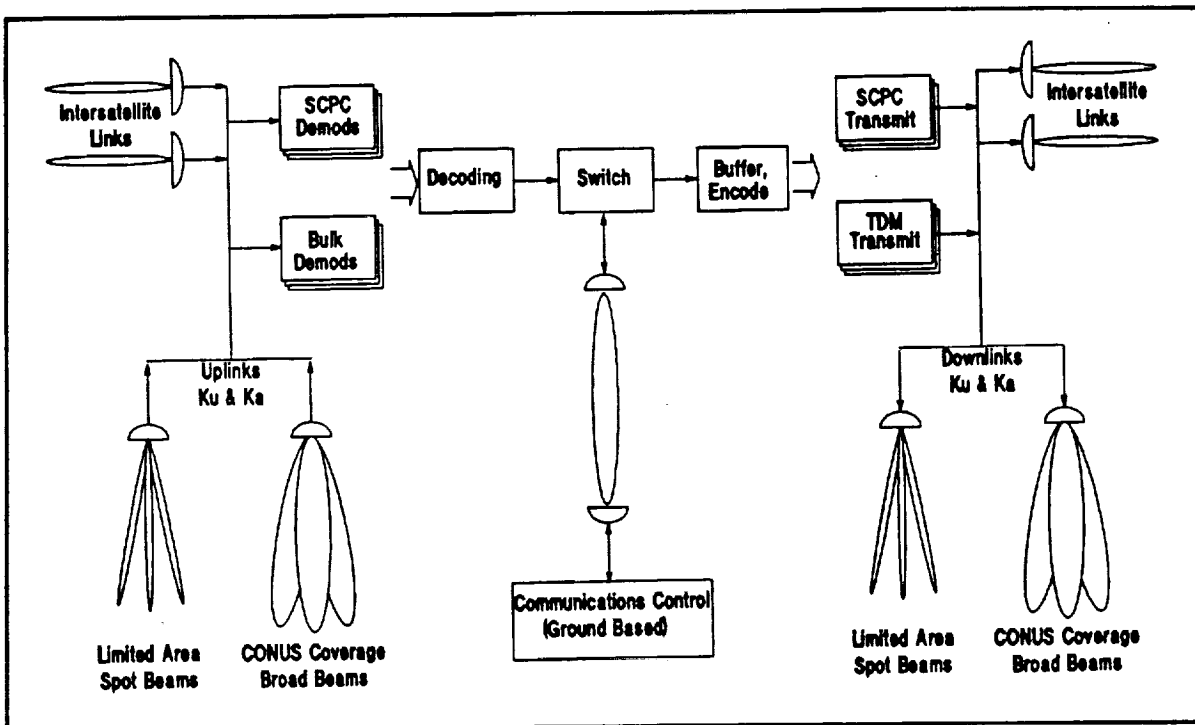

Figure 11 - DDS includes a variety of services: high rate (up to 320 Mbs) communications via small spot beams; lower rate communications via general coverage beams; and intersatellite links to other orbiting platforms.

**EXAMPLE ALLOCATION OF SPACECRAFT POWER
AMONG DDS SERVICES**

		RF Power (W)	Beam Size Deg	Example Allocation Among Users	Peak Capacity Mbps	Example User Network
2800 WATTS TOTAL	2000 Watts 83% Efficiency =724 W RF Ku-Band	269	0.87	1.8m BPSK .749 0192	1,404	27 Links @52 Mbps
		126	0.87	3.0m QPSK .749 090	1,404	27 Links @52 Mbps
		219	0.87	5.0m BPSK .829 0114	1,020	12 Links @160 Mbps
		110	0.87	7.0m BPSK .829 057	1,020	3 Links @320 Mbps
	Subtotal	724			6,848	
	800 Watts 83% Efficiency =248 W RF Ka-Band	32	0.50	1.8m BPSK .749 051	312	6 Links @52 Mbps
		12	0.50	3.0m QPSK .749 023	520	10 Links @52 Mbps
		13	0.50	5.0m QPSK .749 06	1,600	10 Links @160 Mbps
		46	1.73	5.0m BPSK .829 029	1,600	5 Links @320 Mbps
		96	1.73	3.0m BPSK .749 0265	364	7 Links @52 Mbps
49		1.73	5.0m QPSK .749 0118	416	8 Links @52 Mbps	
Subtotal	248			4812		

Figure 12 - On orbit DC power is limited. Careful assignment and control of data links is required to achieve satisfactory utilization without exceeding the power capability.

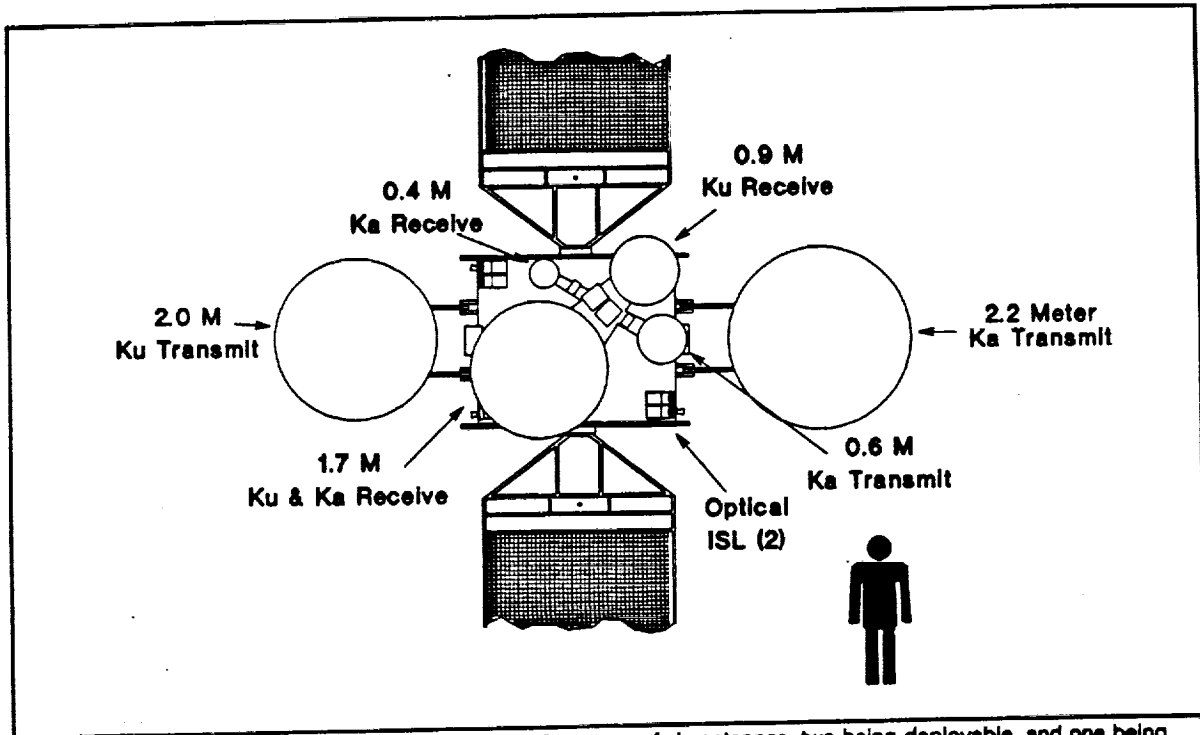

Figure 13 - One version of DDS (LORAL) makes use of an array of six antennas, two being deployable, and one being dual frequency. All are multibeam designs.

DEDICATED GOVERNMENT SYSTEM DUPLEX COST/MBS (1)			COMMERCIAL SYSTEM DUPLEX COST/MBS (2)		
Small User			Small User		
	at 10%	at 7%	@15%	@12%	
Annual	136016	114824	Annual	150567	129562
Monthly	11335	9689	Monthly	12547	10797
Hourly	15.57	13.14	Hourly	17.24	14.83
Minute	0.26	0.22	Minute	0.29	0.25
Large-Medium User			Large-Medium User		
Annual	68008	57412	Annual	75283	64781
Monthly	5667	4784	Monthly	6274	5398
Hourly	7.78	6.57	Hourly	8.62	7.42
Minute	0.13	0.11	Minute	0.14	0.12
Footnote (1)			Footnote (2)		
System Capacity, Gbs	20		System Capacity, Gbs	10	
Average Utilization	0.16		Average Utilization	0.25	
Average Traffic, Gbs	3.2		Average Traffic, Gbs	2.5	

Figure 14 - Comparison of costs for a dedicated government system and a shared commercial system, indicates only a slight cost advantage for the dedicated government system.

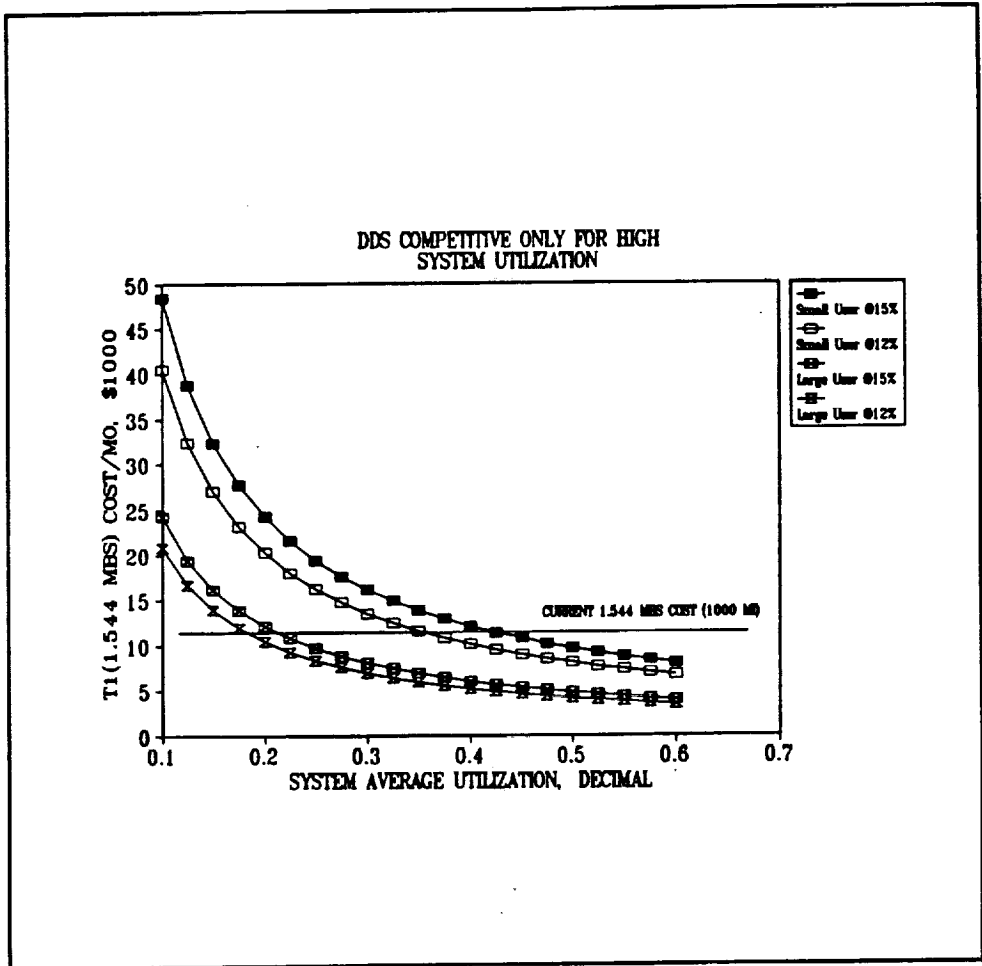

Figure 15 - User DDS charges are very sensitive the average utilization of the system.

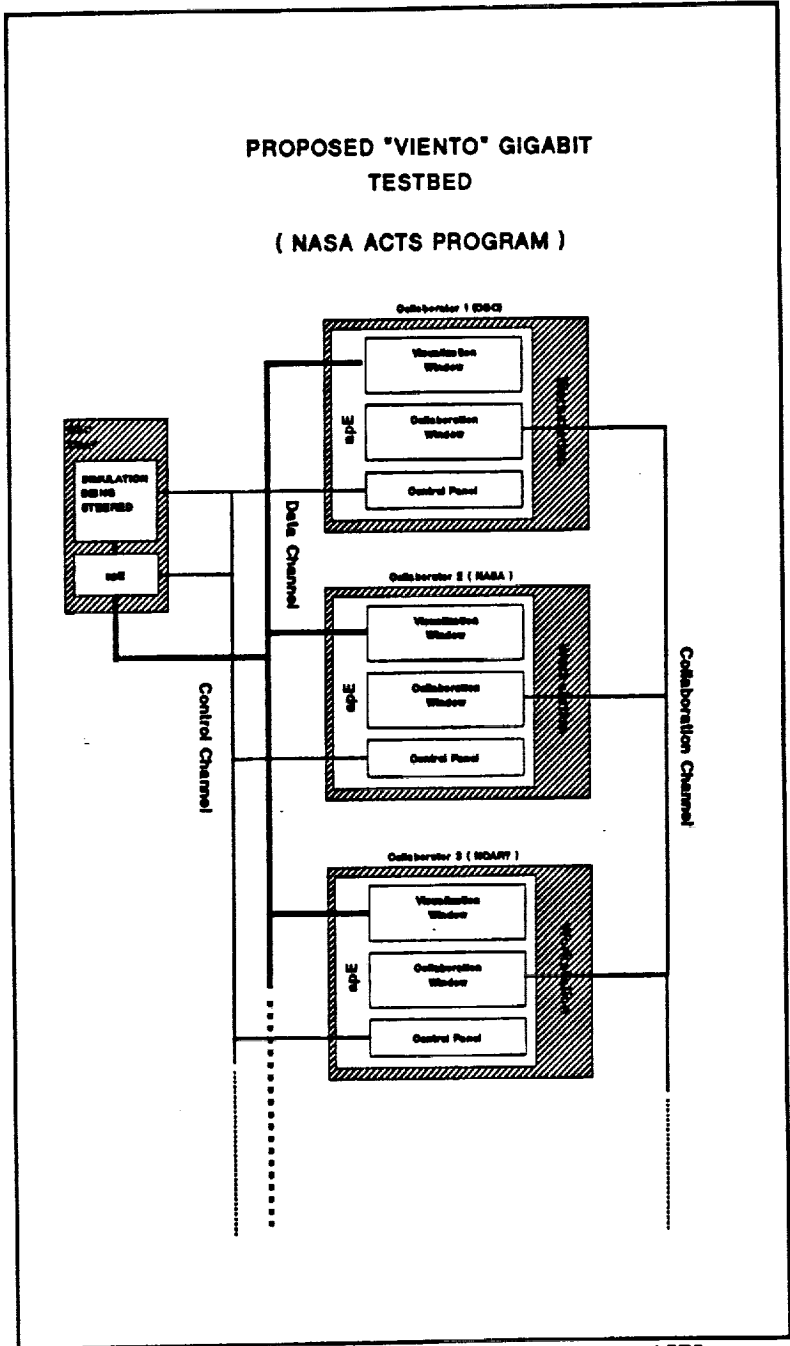

Figure 16 - A proposed telescience/collaboration experiment for ACTS

LAYERED IMPEDIMENTS TO DDS

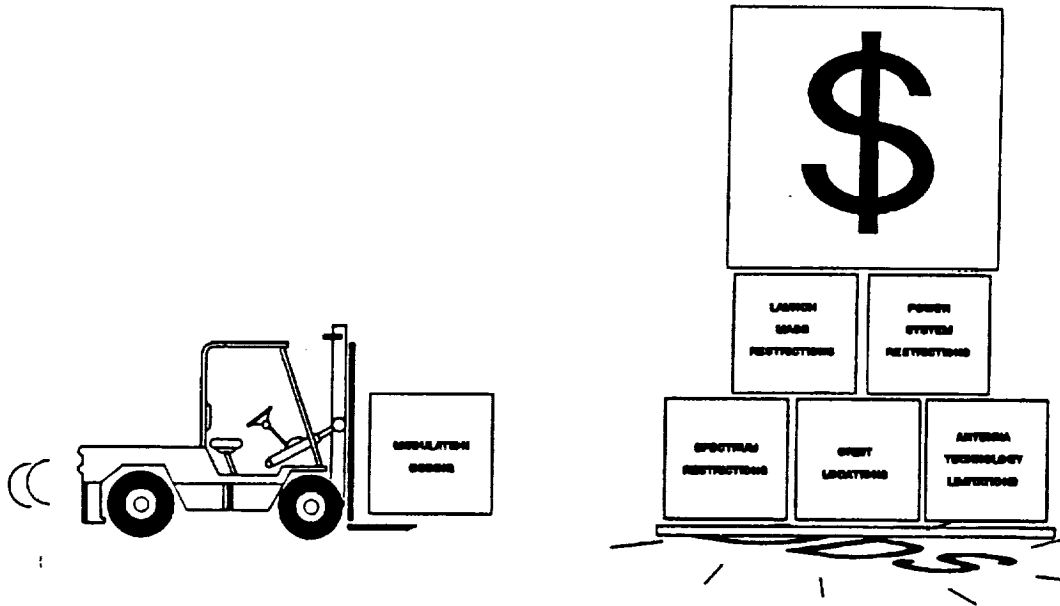

Figure 17 - Removing impediments to implementation of DDS

REPORT DOCUMENTATION PAGE

Form Approved
OMB No. 0704-0188

Public reporting burden for this collection of information is estimated to average 1 hour per response, including the time for reviewing instructions, searching existing data sources, gathering and maintaining the data needed, and completing and reviewing the collection of information. Send comments regarding this burden estimate or any other aspect of this collection of information, including suggestions for reducing this burden, to Washington Headquarters Services, Directorate for Information Operations and Reports, 1215 Jefferson Davis Highway, Suite 1204, Arlington, VA 22202-4302, and to the Office of Management and Budget, Paperwork Reduction Project (0704-0188), Washington, DC 20503.

1. AGENCY USE ONLY (Leave blank)		2. REPORT DATE February 1992	3. REPORT TYPE AND DATES COVERED Technical Memorandum	
4. TITLE AND SUBTITLE Data Distribution Satellite			5. FUNDING NUMBERS WU-144-50-50	
6. AUTHOR(S) Grady H. Stevens				
7. PERFORMING ORGANIZATION NAME(S) AND ADDRESS(ES) National Aeronautics and Space Administration Lewis Research Center Cleveland, Ohio 44135-3191			8. PERFORMING ORGANIZATION REPORT NUMBER E-7205	
9. SPONSORING/MONITORING AGENCY NAMES(S) AND ADDRESS(ES) National Aeronautics and Space Administration Washington, D.C. 20546-0001			10. SPONSORING/MONITORING AGENCY REPORT NUMBER NASA TM-105778	
11. SUPPLEMENTARY NOTES Prepared for the International Space Year Conference on Earth and Space Science Information Systems sponsored by the California Institute of Technology, Pasadena, California, February 10-13, 1992. Grady H. Stevens, NASA Lewis Research Center, Cleveland, Ohio 44135. Responsible person, Grady H. Stevens, (216) 433-3463.				
12a. DISTRIBUTION/AVAILABILITY STATEMENT Unclassified - Unlimited Subject Categories 17 and 32			12b. DISTRIBUTION CODE	
13. ABSTRACT (Maximum 200 words) The Data Distribution Satellite (DDS), operating in conjunction with the planned space network, the National Research and Education Network and its commercial derivatives, would play a key role in networking the emerging supercomputing facilities, national archives, academic, industrial, and government institutions. Centrally located over the United States in geostationary orbit, DDS would carry sophisticated on-board switching and make use of advanced antennas to provide an array of special services. Institutions needing continuous high data rate service would be networked together by use of a microwave switching matrix and electronically steered hopping beams. Simultaneously, DDS would use other beams and on board processing to interconnect other institutions with lesser, low rate, intermittent needs. Dedicated links to White Sands and other facilities would enable direct access to space payloads and sensor data. Intersatellite links to a second generation ATDRS, called Advanced Space Data Acquisition and Communications System (ASDACS), would eliminate one satellite hop and enhance controllability of experimental payloads by reducing path delay. Similarly, direct access would be available to the supercomputing facilities and national data archives. Economies with DDS would be derived from its ability to switch high rate facilities amongst users as needed. At the same time, having a CONUS view, DDS could interconnect with any institution regardless of how remote. Whether one needed high rate service or low rate service would be immaterial. With the capability to assign resources on demand, DDS will need only carry a portion of the resources needed if dedicated facilities were used. Efficiently switching resources to users as needed, DDS would become a very feasible spacecraft, even though it would tie together the space network, the terrestrial network, remote sites, 1000's of small users, and those few who need very large data links intermittently.				
14. SUBJECT TERMS Data distribution; Satellites; Information systems; Space data relay; Antennas; Onboard processing; Modulation			15. NUMBER OF PAGES 16	
			16. PRICE CODE A03	
17. SECURITY CLASSIFICATION OF REPORT Unclassified	18. SECURITY CLASSIFICATION OF THIS PAGE Unclassified	19. SECURITY CLASSIFICATION OF ABSTRACT Unclassified	20. LIMITATION OF ABSTRACT	