

NASA Conference Publication 3066

A Lunar Optical- Ultraviolet-Infrared Synthesis Array (LOUISA)

(NASA-CP-3066) A LUNAR
OPTICAL-ULTRAVIOLET-INFRARED
SYNTHESIS ARRAY (LOUISA) (New
Mexico Univ.) 294 p

N93-13579
--THRU--
N93-13601
Unclas

H1/89 0131730

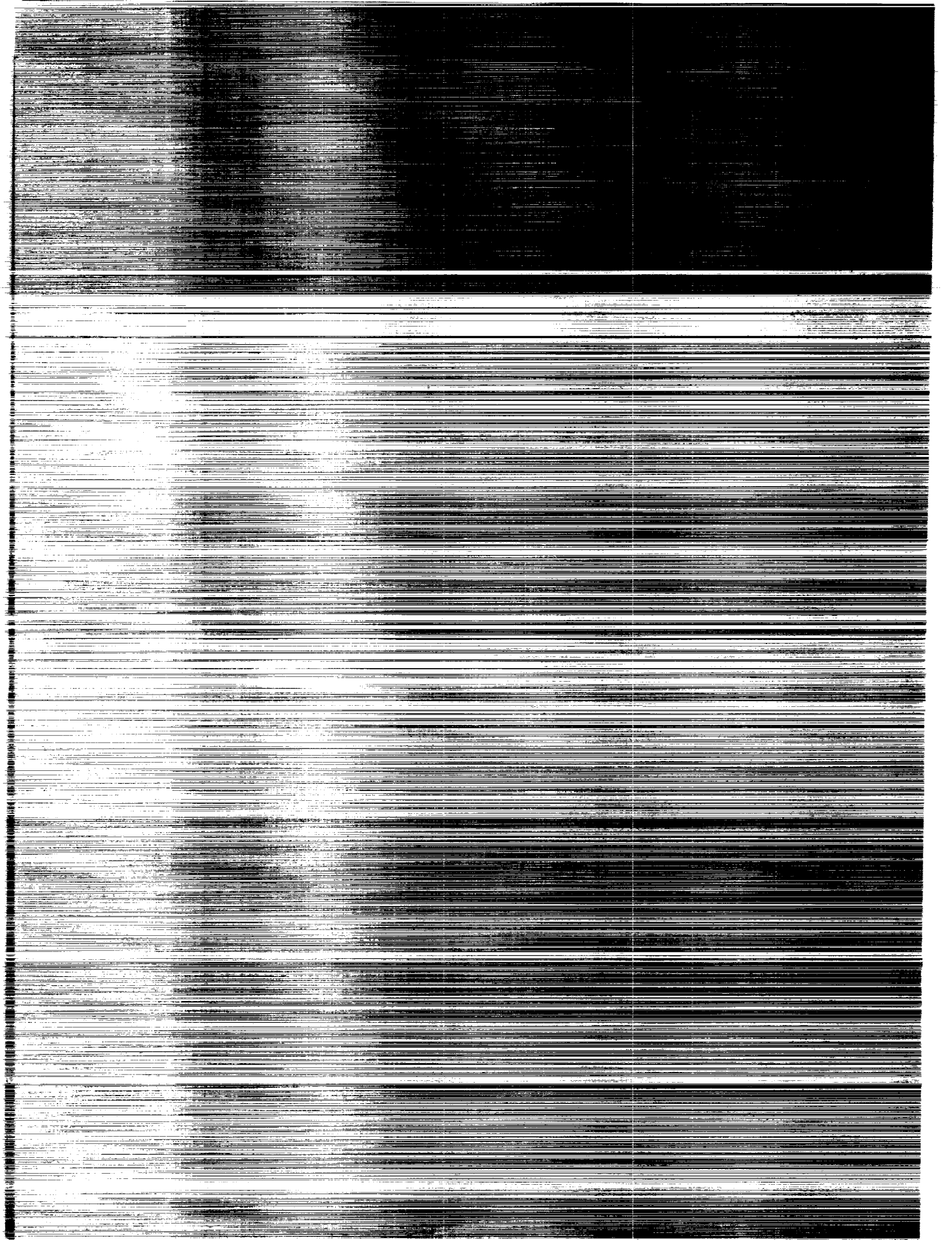

NASA Conference Publication 3066

A Lunar Optical- Ultraviolet-Infrared Synthesis Array (LOUISA)

Edited by

Jack O. Burns
*New Mexico State University
Las Cruces, New Mexico*

Stewart W. Johnson
*The BDM Corporation
Albuquerque, New Mexico*

Nebojsa Duric
*The University of New Mexico
Albuquerque, New Mexico*

Proceedings of a workshop sponsored by the
National Aeronautics and Space Administration,
Washington, D.C., and held at
The University of New Mexico
Albuquerque, New Mexico
February 8-10, 1989

NASA

National Aeronautics and
Space Administration

Office of Management

Scientific and Technical
Information Program

1992



CONTENTS

Section	Page
<u>PROLOGUE</u>	
Jack O. Burns, New Mexico State University	vi
<u>ATTENDEES</u>	viii
FINAL AGENDA FOR THE LOUISA WORKSHOP	x
<u>PART I - INTRODUCTION</u>	1
Introduction	
Jack O. Burns, New Mexico State University	2
Radio and Optical Interferometric Imaging	
T. J. Cornwell, National Radio Astronomy Observatory	7
<u>PART II - GROUND-BASED OPTICAL AND INFRARED INTERFEROMETERS</u>	17
The CHARA Optical Array	
Harold A. McAlister, Georgia State University	18
The Mount Wilson Optical Interferometer: The First Automated Instrument and the Prospects for Lunar Interferometry	
K. J. Johnston et al., Naval Research Laboratory	35
The Optical Very Large Array and Its Moon-Based Version	
Antoine Labeyrie, CERGA/OCA	49
High Resolution Imaging at Palomar	
Shrinivas R. Kulkarni, California Institute of Technology	59
Recent Astronomical Results from the Infrared Spatial Interferometer and their Implications for LOUISA	
W. C. Danchi et al., University of California at Berkeley	75
Shot Noise Limits to Sensitivity of Optical Interferometry	
Sudhakar Prasad, University of New Mexico	93

<u>PART III - SPACE-BASED INTERFEROMETERS</u>	108
Orbiting Space Interferometer (OSI): A First Generation Space Interferometer Michael Shao, Jet Propulsion Laboratory	109
HARDI: A High Angular Resolution Deployable Interferometer for Space Pierre Y. Bely et al., Space Telescope Science Institute	114
Support and Servicing Requirements for Large Observatories in Space Thomas E. Styczynski, Lockheed Missiles & Space Company	127
Science Objectives for Ground- and Space-Based Optical/IR Interferometry Stephen T. Ridgway, National Optical Astronomy Observatories	132
<u>PART IV - LUNAR INTERFEROMETRIC ARRAYS</u>	144
Telescopes on the Moon or Pie in the Sky? Carl B. Pilcher, NASA Headquarters	145
Lunar Interferometric Astronomy: Some Basic Questions N. Woolf, University of Arizona	157
Lunar Optical Telescopes: An Historical Perspective Stewart W. Johnson, BDM International, Inc.	163
The Lunar Environment and Its Effect on Optical Astronomy G. Jeffrey Taylor, University of Hawaii	183
Environmental Effects on an Optical-UV-IR Synthesis Array Stewart W. Johnson et al., BDM International, Inc.	196
An Optical VLA on the Moon Bernard F. Burke, Massachusetts Institute of Technology	210
Appendix: Limits on the Use of Heterodyning and Amplification in Optical Interferometry Bernard F. Burke, Massachusetts Institute of Technology	225
Required Technologies for a Lunar Optical-UV-IR Synthesis Array Stewart W. Johnson and John P. Wetzal, BDM International, Inc.	227
<u>PART V - REPORTS FROM THE WORKING GROUPS</u>	242
Report of the Working Group on Space/Lunar Tradeoffs	243
Report of the Science Working Group: Science with a Lunar Optical Interferometer	249
Report of the Design Working Group	256

PART VI - FINALE	279
Remarks at Closing Panel	
Harlan J. Smith, University of Texas	280
Summary and Conclusions/Future Work	
Jack O. Burns, New Mexico State University	282

PROLOGUE

The year 1989 marked the 20th anniversary of humankind's first expedition to the Moon. Apollo 11 reached the lunar surface on July 20, 1969. The lunar landing represented the apex of America's manned space program. Apollo helped to generate a level of interest in space, and in science and technology in general, that was unprecedented. In addition to the tangibles such as medical and computer spinoffs, the Apollo Program produced an equally important intangible -- an uplift in the spirit and the confidence of the nation in its technological abilities.

For the first time in nearly 20 years, serious discussion concerning the establishment of a permanent base on the Moon is beginning. Such a program will be driven by the recognition that the Moon is an important base for research and resources, and can serve as a key training ground for future manned expeditions to Mars.

Several major reports have been issued in the past few years that point out advantages and opportunities of the Moon. "Pioneering the Space Frontier," a report of National Commission on Space, described an ambitious program of manned and unmanned explorations of the solar system with a lunar base representing a cornerstone of this push beyond Earth's Orbit. Following the explosion of the Shuttle Challenger, former astronaut Sally Ride and her colleagues at NASA headquarters undertook a re-evaluation of NASA's goals in space. They found that America's space efforts lacked the sharp focus of the Apollo Program and, as a result, did not inspire the Public as they did in the 1960s. In an effort to recapture this momentum, Ride recommended major new initiatives, possibly including the establishment of a permanently staffed station on the Moon. Similar sentiments are inherent in the national space policy issued by the Reagan administration in 1988. More recently, President Bush, speaking on the 20th anniversary of the Apollo 11 landing, appeared to strongly endorse a lunar outpost. He proclaimed "I'm proposing a long-range, continuing commitment. First, for the coming decade--Space Station Freedom--our crucial next step in all our space endeavors. And next--for the new century--back to the Moon. Back to the future. And this time, back to stay."

An outpost on the Moon, coupled with its associated transportation system and infrastructure, offers some very exciting opportunities for astronomy (see, for example, Burns and Mendell 1988). In particular, at the first Lunar Bases and Space Activities Symposium held in Washington, D. C. in 1984, Bernie Burke proposed that the lunar surface would be an ideal location for a long-baseline optical interferometer. Such a telescope, placed on an airless and geologically stable surface, would be capable of extraordinary resolutions--of order 10 microarcsec at 0.5 microns for a 10-km baseline. Astronomers are very seldom presented with an opportunity for such a gigantic leap in resolution and, therefore, opportunities to explore new classes of problems.

The revitalized interest in the Moon as a scientific research base coupled with the long lead times inherent in complex space-based projects such as the Hubble Space Telescope helped to motivate a workshop on the general topic of a Lunar Optical-UV-IR Synthesis Array (LOUISA). This workshop was held at BDM International, Inc., in Albuquerque, N.M., February 8 - 10, 1989. It was sponsored by NASA, The University of New Mexico's Institute for Astrophysics, and BDM. The workshop brought together about 50 scientists and engineers from a wide variety of backgrounds. The academic, national laboratory, national observatory, and industrial communities were all represented. The diverse expertise of the assembled group led to many interesting discussions on design and emplacement of LOUISA, systems engineering, transportation of components, cost and, of course, the exciting science that one might do with such a device.

The goals of the workshop were two-fold. First, there had not been a conference on optical interferometry for about two years and none was planned for the immediate future. The LOUISA workshop offered an excellent opportunity for us to acquaint each other with some of the latest results from ground-based experiments and to learn about plans for future experiments in space and on the ground. This goal was accomplished through a series of 20-minute invited presentations from some of the leading researchers in the field during the first day and a half of the workshop. Second, we were then in an excellent position to begin to extrapolate these concepts to the lunar environment in the 21st century. We did this by forming three working groups on the topics of science, Space-Moon location tradeoffs, and engineering and design of LOUISA. We spent about a day in intensive discussions within the working groups formulating plans, strategies, and modes of implementation of the LOUISA concept. On the morning of the final day, we reassembled to hear reports by the working groups. We were very pleased by the general consensus of the three groups. The Space/Moon tradeoffs group had formulated some strong arguments for the Moon as the preferred location of a 10-km baseline array. The science working group found very strong science drivers for LOUISA. The engineering/design group significantly advanced Burke's original concept and offered engineering specifications that were well matched to the science objectives.

We hope that these proceedings of the LOUISA workshop reflect the genuine interest, excitement and hope that were generated during our three-day conference. We offer these collective thoughts in an effort to foster more discussion, criticism, and feedback on the general concept of lunar observatories and LOUISA in particular.

I thank the members of the organizing committee, Stewart Johnson, Neb Duric, and Doug Nash, for their generous help in putting the program together and making it run smoothly. We are also indebted to the co-chairs of the working groups, John Basart, Mitch Begelman, Jeff Taylor, and Mike Shao, for their efforts. We thank the members of the summary panel for sharing their thoughts and insights with us. This workshop would not have been possible without the funding from NASA. We thank Carl Pilcher from NASA Headquarters and Mike Duke from the Johnson Space Center for their efforts in helping us to secure this funding. Finally, I thank the BDM Corporation for the use of their new conference facilities and Ms. Jean Helmick of BDM for her outstanding efforts in coordinating the conference.

Jack O. Burns
New Mexico State University
July 1989

ATTENDEES

Akgul, Ferhat	University of New Mexico (UNM)	Turkey
Anatharamaiah, Kuduvalli	National Radio Astronomy Observatory (NRAO)	India
Basart, John	Iowa State University	
Begelman, Mitch	University of Colorado	French
Bely, Pierre	Space Telescope Science Institute	
Bolinger, Loren	Rio Grande Technology	
Breckenridge, James	Jet Propulsion Laboratory (JPL)	
Briggs, Dan	NRAO	
Brown, Robert A.	Space Telescope Science Institute	
Burke, Bernard	Massachusetts Institute of Technology (MIT)	
Burns, Jack	New Mexico State University	Singapore
Chua, Koon Meng	UNM	
Cornwell, Tim	NRAO	
Crane, Pat	NRAO	
Danchi, Bill	University of California at Berkeley	
Dehainout, Christopher	Kirtland Air Force Base	Belgium
Diels, Jean-Claude	UNM	
Dumont, Philip	JPL	Canada
Duric, Neb	UNM	Algeria
Fernini, Ilias	UNM	
Garcia, Chris	UNM	
Ge, J.	NRAO	China
Gerstle, Walt	UNM	
Ghiglia, Dennis	Sandia National Laboratories	
Gibson, Dave	MIT Lincoln Laboratories	
Goss, Miller	NRAO	China
Han, S.	NRAO	
Harvey, James	Perkin-Elmer	
Helmick, Jean K.	BDM International, Inc.	
Hicks, Jeff	UNM	
Johnson, Stewart	BDM International, Inc.	
Johnston, Ken	Naval Research Lab	British
Kibblewhite, Edward	University of Chicago	
Kulkarni, Shrivias	Cal Tech	French
Labeyrie, Antoine	CERGA	
Leahy, Patrick	NRAO	
Loos, Gary	UNM	
Lunsford, Lee	Lockheed Missiles and Space Company (LMSC)	
McAlister, Harold	Georgia State University	
Nash, Doug	JPL	Canada
Perley, Rick	NRAO	
Pilcher, Carl	NASA Headquarters	
Prasad, Sudhar Kak	UNM	
Price, Marcus	UNM	
Ridgway, Steve	National Optical Astronomy Observatories	
Salgado-Fernandez, Nilo	UNM	
Shao, Michael	JPL	
Singer, Neal E.	UNM	
Smith, Harlan	University of Texas McDonald Observatory	
Styczynski, Tom	LMSC	

Taylor, Jeff	University of Hawaii
Wetzel, John	BDM International, Inc.
Woolf, Neville	University of Arizona
Zeilik, Mike	UNM
Zensus, Anton	NRAO

NEWS MEDIA:

Crawford, Charles	CNN
Davis, Christopher	CNN
Walter, Amy	CNN
Holmes, Sue	Associated Press
Young, Steve	Associated Press
Spohn, Larry	Albuquerque Tribune
Spice, Byron	Albuquerque Journal
Maurer, Rachael	National Public Radio
Entrikin, Brenda	KOB Radio, Albuquerque
Chapa, Arcie	KGGM, Albuquerque
Herne, Raymond	KOAT, Albuquerque
Loy, Kirk	KGGM, Albuquerque
Simmons, Wayne	KOAT, Albuquerque

FINAL AGENDA FOR THE LOUISA WORKSHOP

FEBRUARY 8, 1989:

8:30 - 8:45 Welcoming Remarks - James J. Silkora, Senior V.P., BDM International, Inc.,
F. Chris Garcia, V.P. for Academic Affairs,
University of New Mexico

8:45 - 9:15 Introductory Remarks - J. O. Burns, New Mexico State University

9:15 - 9:45 Radio & Optical Interferometric Imaging - T. J. Cornwell, National Radio
Astronomy Observatory

GROUND-BASED OPTICAL INTERFEROMETERS - B. Burke, Chair

9:45 - 10:05 The CHARA Optical Array - H. McAlister

9:05 - 10:25 The Design of a Five-Telescope Ground-Based Interferometric Array -
E. Kibblewhite

10:25 - 10:40 Coffee Break

10:40 - 11:00 Results from the Mt. Wilson Interferometer - K. Johnston

11:00 - 11:20 The Ground-Based Optical Very Large Array and Its Moon-Based Version -
A. Labeyrie

11:20 - 11:40 Some Recent Astronomical Results from the IR Spatial Interferometer & their
Implications for the LOUISA Telescope - W. Danchi

11:40 - 12:00 Announcements & Discussion

12:00 - 2:00 Lunch

LIMITS ON GROUND-BASED ARRAYS - H. Smith, Chair

2:00 - 2:20 Photon Shot-Noise Considerations in Ideal Optical Interferometry- S. Prasad

2:20 - 2:40 High Resolution Imaging from Palomar and Sensitivity Limits to Ground-Based
Imaging - S. Kulkarni

2:40 - 3:00 Field of View Limits of Arrays - J. Harvey

SPACE-BASED INTERFEROMETERS - L. Lunsford

3:00 - 3:20 A Four-Telescope-Wide Field of View Phased Array - C. Dehainaut

3:20 - 3:40 Coffee Break

- 3:40 - 4:00 Science Objectives of Optical/IR Interferometry from the Ground & Space - S. Ridgway
- 4:00 - 4:20 A First Generation Optical Interferometer on the Space Station - M. Shao
- 4:20 - 4:40 HARDI: A High Angular Resolution Deployable Interferometer - P. Bely
- 4:40 - 5:00 The Support and Servicing Requirements for Large Observatories in Space - T. Styczynski

FEBRUARY 9, 1989

LUNAR INTERFEROMETRIC ARRAYS - K. Johnston

- 8:30 - 9:00 The Lunar Environment - J. Taylor
- 9:00 - 9:20 Lunar Optical Telescopes: An Historical Perspective - S. Johnson
- 9:20 - 10:00 Concept for an Optical VLA on the Moon - B. Burke
- 10:00 - 10:30 Coffee Break
- 10:30 - 10:50 Optical-IR-Submillimeter Imaging from the Moon: Letting the Problems Define the Instruments - N. Woolf

WORKING GROUP DEFINITIONS

- 10:50 - 11:10 Science Working Group - N. Duric
- 11:10 - 11:30 Engineering/Design Working Group - S. Johnson
- 11:30 - 11:50 Space/Moon Tradeoffs Working Group - D. Nash
- 11:50 - 2:00 Lunch

WORKING GROUP MEETINGS

- 2:00 - 5:00 Individual Group Discussions
- 6:00 - 7:00 No-host Cocktail Hour - Amfac Hotel
- 7:00 - 9:00 Banquet - Amfac Hotel;
After dinner talk by Carl Pilcher (NASA HQ) entitled "Telescopes on the Moon or Pie in the Sky?"

FEBRUARY 10, 1989 (Move to Randolph Conference Center, BDM International, Inc.)

WORKING GROUP MEETINGS

8:00 - 10:00 Individual Group Discussions

REPORTS FROM WORKING GROUP CHAIRS

10:00 - 10:20 Science - N. Duric

10:20 - 10:40 Engineering/Design - S. Johnson

10:40 - 11:00 Space/Moon Tradeoffs - D. Nash

SUMMARY PANEL

11:00 - 12:30 Summary of the Workshop:

J. Burns, Moderator

M. Begelman

A. Labeyrie

H. Smith

L. Lunsford

C. Pilcher

12:30 ADJOURN

PART I

REASONS FOR PERFORMING ASTRONOMY ON THE MOON

This section begins with an overview of the characteristics that make the lunar surface particularly attractive for an optical interferometer. After these introductory remarks by J. Burns, a general review of radio and optical interferometry is presented by T.J. Cornwell from NRAO. This review provides the necessary background for readers who may be unfamiliar with image reconstruction from synthetic aperture telescopes.

I. INTRODUCTION

Jack O. Burns

Department of Astronomy
New Mexico State University
Las Cruces, NM 88003

Over the past half-dozen years, a strengthening case for astronomical observatories on the Moon has been presented (Burns and Mendell 1988; Mendell 1985). The Moon has a number of physical characteristics that make it very attractive as a site for observatories in the next century. These features include a very large surface on which large structures can be built. In other space environments, such as low Earth orbit (LEO), one must construct either very large platforms or perform complex and costly station-keeping of individual telescopic elements for long baseline (>1 km) arrays. The Moon is the only other location within the Earth-Moon system on which one can build using techniques similar to that developed on Earth. In addition, the lunar gravity is generally perceived as an advantage. The Apollo and Space Shuttle missions have demonstrated that construction in the 1/6-g of the Moon is easier than in the zero-g of LEO (although still nontrivial). A preliminary study has found no practical limitation in building very large astronomical structures (e.g, large, fully steerable antennas or large area optical mirrors) on the Moon due to the finite, but low gravity (Akgul et al. 1990).

The atmosphere on the moon is essentially negligible for astronomical purposes. The average night-side density of neutral molecules is about 10^5 cm^{-3} (Hoffman et al. 1973), and the ionospheric density is about $<100 \text{ cm}^{-3}$ (Douglas and Smith 1985). This means that the optical depth at ultraviolet wavelengths is about 10^{-6} and the plasma frequency is $<90 \text{ kHz}$. Therefore, the lunar atmosphere does not impede astronomical observations at any practical wavelength.

The Moon is also a remarkably stable platform (Goins et al. 1981). Typical seismic energy is 10^{-8} times that of the average on the Earth. There are occasional moonquakes but most are in the magnitude 1 to 2 range on the Richter scale. Furthermore, the nature of the subsurface layers (i.e., crushed rubble from extensive meteor impacts) is such that seismic waves are quickly damped near the disturbance, propagating more like a diffusion process than a wave process as on Earth. Typical ground motions on the Moon are of order 1 nm. This stability is an important asset for optical interferometers where one must track the baseline to within a fraction of a wavelength.

The lunar farside is a natural radio-quiet zone. Radio observatories on the farside would be free of both the natural and man-made sources of interference coming from the Earth. The Radio Astronomy Explorer Satellite showed the Earth's magnetotail to be a tremendous source of electromagnetic radiation (several orders of magnitude high levels than the galactic background) below 1 MHz (auroral kilometric radiation) making it nearly impossible to do very low frequency observations from LEO as well as from the ground. Thus, the lunar farside may be the only practical location within the inner solar system from which astronomers might open the last of the windows to the electromagnetic spectrum.

Finally, unlike all other space-based locations, the Moon has an abundance of raw materials. Aluminum, ceramics, and high tensile strength glasses are available. Numerous proposals have been advanced to mine these raw materials from the Moon and refine them into useful products (Mendell 1985). By the middle of the 21st century, very few components for astronomical telescopes may need to be brought from Earth. This will be a great cost savings and should enhance the efficiency of the Moon for astronomy.

As with any venture in space, there are some concerns with the Moon. For example, without the protective magnetic field of the Earth, cosmic rays rain down on the lunar surface. Precautions need to be taken for humans constructing observatories and for sensitive electronics (e.g., CCD detectors). Similarly, there is a constant flux of micrometeoroids that land on the lunar surface. Analysis of the Apollo data suggest that microcraters in the 1 to 10 micron range will be common on surfaces exposed on the Moon (Johnson, Taylor, and Wetzel 1990). Therefore, some protection for mirrors on optical telescopes will be necessary. The temperature variation on the Moon is also large, ranging from 100⁰K at night to 385⁰K during the day (Keihm and Langseth 1973). Some provision must be made to deal with the resulting thermal strains that may deform large area telescopes, such as a judicious choice of composite metal matrix materials (Akgul, Gerstle, and Johnson 1990). Lastly, there is the issue of pollution. It has been suggested (Vondrak 1974) that a vigorous lunar base may generate a very long-lived, relatively dense artificial lunar atmosphere that could substantially degrade astronomical observations. Further analysis of this problem suggests that with modest precautions, ambitious mining and manufacturing should not preclude astronomical observations from the Moon (Fernini et al. 1990).

A wealth of scientific problems would be available for study with an instrument like LOUISA with a resolution of about 10 microarcsec. These include the search for extrasolar

planets, stellar seismology, high resolution studies of the collapse and formation of new stars, the formation of collimated outflows near compact objects, and measuring the cosmic deceleration parameter.

Thus, one can see that there are some significant environmental and scientific advantages for building a long-baseline optical interferometer on the Moon. These advantages must, however, be judged against other factors such as the effects of micrometeoroids, cost, and other possible locations for the interferometer in proximity to the Earth. These topics will be discussed in the following contributed papers and in the reports from the three working groups.

References

1. Akgul, F.; Gerstle, W.; Johnson, S. 1990. Engineering, Construction, and Operations in Space II, Proceedings of Space 90, American Society of Civil Engineers: NY, p. 697.
2. Burns, J.O.; Mendell, W.W., eds. 1988. Future Astronomical Observatories on the Moon, NASA Conference Publication 2489.
3. Douglas, J.; Smith, H.J. 1985. Lunar Bases and Space Activities of the 21st Century, W. Mendell ed., LPI: Houston, p. 301.
4. Fernini, I.; Burns, J.; Taylor, G.J.; Sulkanen, M.; Duric, N.; Johnson, S. 1990. J. Spacecraft and Rockets 27: 527.
5. Goins, N. R.; Dainty, A.M.; Toksoz, M.N. 1981. J. Geophys. Res. Ram 86: 378.
6. Hoffman, J.H.; Hodges, R.R.; Johnson, F.S. 1973, Proc. Lunar Sci. Conf. 4th Publication Pergamon Press: NY, p. 2,865.
7. Johnson, S.W.; Taylor G.J.; Wetzel, J.P. 1990. These proceedings.
8. Keihm, S.J.; Langseth, M.G. 1973. Proc. Lunar Sci. Conf. 4th, Pergamon Press: NY, p. 2,503.

9. Mendell, W.W., ed. 1985. Lunar Bases and Space Activities of the 21st Century, LPI: Houston.
10. Vondrak, R.R. 1974, Nature 248: 657.

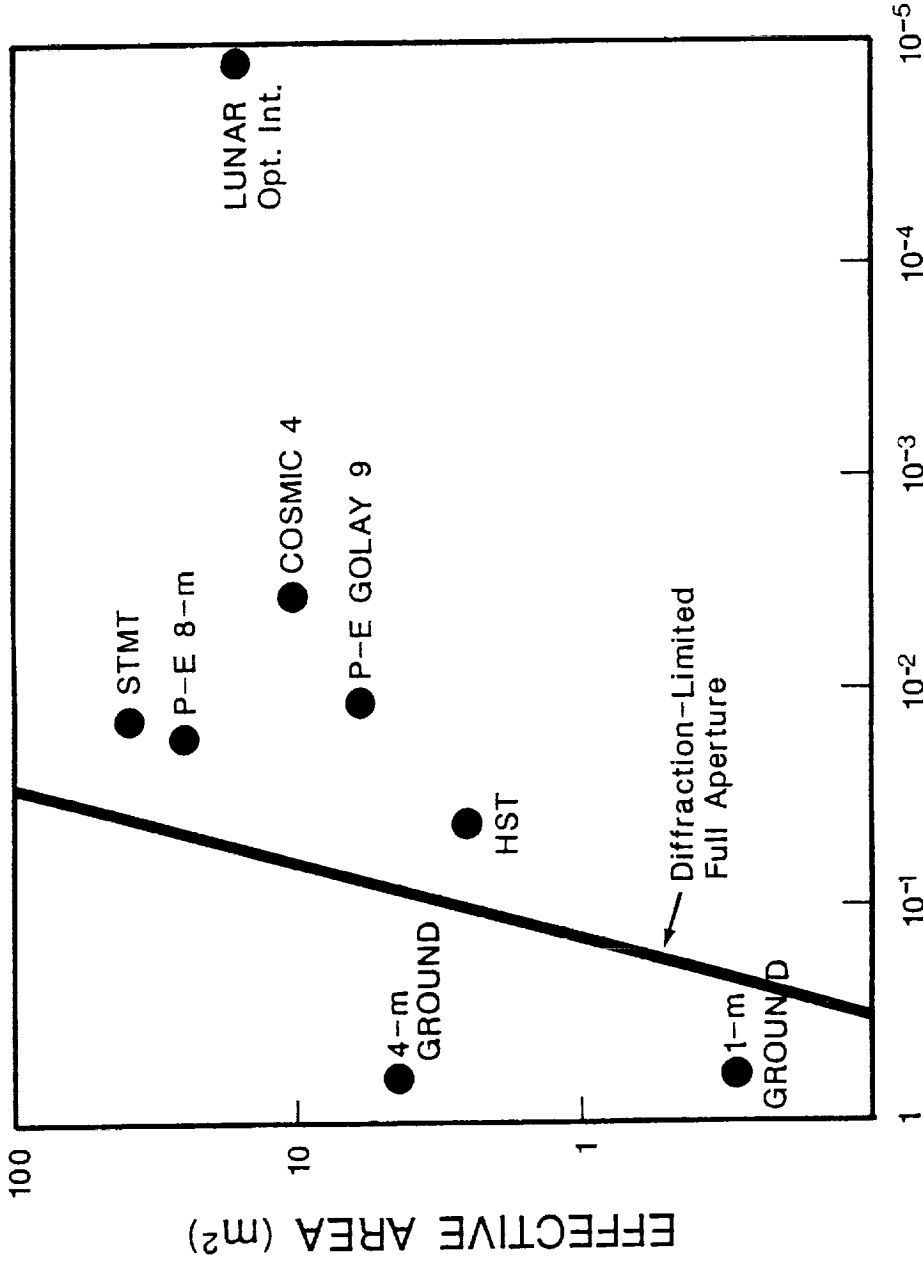

ANGULAR RESOLUTION (ARC SEC)

Comparison of resolutions between filled apertures on the ground and in space, and proposed interferometers in space and on the lunar surface.

RADIO AND OPTICAL INTERFEROMETRIC IMAGING

T.J. Cornwell

National Radio Astronomy Observatory*

P.O. Box O

Socorro, NM 87801

Abstract

Since diffraction-limited imaging with a single aperture yields angular resolution $\sim \lambda / D$, the attainment of high angular resolution with single apertures requires the construction of correspondingly large monolithic apertures, the whole surface of which must be figured to much less than a wavelength. At the longer wavelengths, it is impossible to build a sufficiently large single aperture: for example, at λ 21 cm, arcsec resolution requires an aperture of diameter ~ 50 km. At the shorter wavelengths, the atmosphere imposes a natural limit in resolution of about one arcsec. However, another route is possible; that is, using synthetic apertures to image the sky. Synthetic apertures are now in use in many fields, e.g., radio interferometry, radar imaging, and magnetic-resonance imaging. Radio-interferometric techniques developed in radio astronomy over the past 40 years are now being applied to optical and IR astronomical imaging by a number of groups. Furthermore, the problem of figuring synthetic apertures is considerably simpler, and can be implemented in a computer: new "self-calibration" techniques allow imaging even in the presence of phase errors due to the atmosphere.

Introduction

At the beginning of this century, Michelson investigated the use of interferometry for high resolution measurements of stellar diameters. Figure 1 shows a schematic of his interferometer. Light is collected from two mirrors, A and B, and interfered at a focal point. The contrast of the fringes yields information about the source structure. The position of the fringes (which is the

*Associated Universities Inc. operates the National Radio Astronomy Observatory under National Science Foundation Cooperative Agreement AST-8814515.

fringe phase) also encodes source information but it is rather more sensitive to instrumental errors since, for example, a change in the position of mirror A will also shift the fringes. We will return to this point later. Imaging from coherence measurements relies on the van Cittert-Zernike theorem, which states that for an incoherent object, the coherence of the electric field far from the object is the Fourier transform of the sky brightness function. The complex coherence function of the electric field, E , between two points, Q_1, Q_2 is defined as:

$$\Gamma(Q_1, Q_2) = \langle E(Q_1, t) E^*(Q_2, t) \rangle_t \quad (1)$$

At radio wavelengths, this can be calculated directly using digitization of the received electric fields while, for optical wavelengths, it can be found from modulation of the position of a mirror such as A, by a distance corresponding to $\lambda/4$. The coherence function is the Fourier transformation of the sky brightness, $I(x)$ (see Thompson et al. 1986).

$$\Gamma(u_1, u_2) = \int_C I(x) e^{i \frac{2\pi}{\lambda} (u_1 - u_2) \cdot x} dx \quad (2)$$

where u is the position vector from Q as projected on a plane perpendicular to the line of sight, x is an angular Cartesian coordinate system centered on the object, and C is the field of view of the array elements. Therefore, an interferometer measures a single Fourier coefficient of the sky brightness with a spatial frequency dependent on the separation and orientation of the interferometer elements as seen from the object. In 1960, Ryle and Hewish (1960) pointed out that one could synthesize a large aperture by collecting coherence samples with an interferometer using many different spacings of the elements, and then Fourier-transforming the resulting sampled coherence function in a computer to make an image. The concept of a synthetic aperture holds for all wavelengths but the technology required for the measurements differs considerably. These differences will be addressed in the following talks.

Interferometer and Array Design

While all imaging interferometric arrays measure the coherence function of the radiation from a celestial source, the details of instrumentation needed vary depending principally on the wavelength range and the maximum separation of elements in the array. Hence, I will

concentrate on two typical cases: a radio interferometer designed to operate at centimeter wavelengths, and an optical interferometer. I will follow the signal through both systems.

Light collection: The light can be collected by simple mirrors or by telescopes in the optical, and by parabolic reflectors in the radio. The size of these is limited by the coherence size of the atmosphere in the optical, and by budget in the radio.

Amplification: In the radio, the signals can be amplified without significant loss in signal-to-noise ratio (SNR) while, in the optical, such amplification is both technically impossible and theoretically unattractive (since it would introduce noise equivalent to a black body which peaks at optical wavelengths). The lack of amplification at optical wavelengths means that it is unattractive to divide the light into more than two or three interferometers simultaneously. This is in contrast to the radio regime, where there is no penalty for operating many interferometers simultaneously.

Heterodyne: Radio interferometers always operate as heterodyne systems; that is, the radiation after amplification is converted to some lower frequency for subsequent processing. For optical wavelengths, the fractional bandwidth accessible by heterodyne techniques is prohibitively small.

Light Relay: The light must be relayed to a central location for measurement of the coherence. In the optical, either propagation in an evacuated pipe or along an optical fiber is possible (although free space propagation is possible on the Moon). In the radio, there are many possibilities: cable, waveguide, microwave links, or tape recording and playback.

Digitization: In the radio, the signals from each element can be digitized, usually to one or two bits of precision. This enables the use of digital circuits for many subsequent steps. In the optical regime, this requires the use of low-bandwidth heterodyne systems and has not yet been attempted.

Delay Compensation: The geometry of an interferometer is usually such that the wavefront from a given object will reach one element before another. The light must, therefore, be delayed by the corresponding amount and, furthermore, this delay must be tracked continuously as the Earth rotates. This fringe acquisition and tracking is performed using moving mirrors in

the optical, and digital delays and frequency synthesizers in the radio. Errors in the assumed geometry can result in the loss of coherence.

Correlation: At radio wavelengths, the coherence can be evaluated using a special-purpose digital computer to perform the multiplication and averaging required. This means that very high quality measurements of the coherence are possible. In the optical regime, analogue methods must be used. The light is brought together at one point and interfered. Modulation of the light path in one arm by $\lambda/4$ enables the phase to be measured. High-quality optical correlators are now being built using optical fibers for many of the steps.

Sampling of the coherence function over the synthesized aperture can be accomplished either by physically moving the interferometer elements or by allowing the rotation of the Earth to do so or by a combination of both approaches (see Thompson et al. 1986 for a detailed discussion of the design of radio interferometric arrays). For short baselines, up to some tens of kilometers, the signal transmission system may limit the layout of an array, as may the local geography, and the need to move the elements. Figure 2 shows a modern radio-interferometric array, the National Radio Astronomical Observatory (NRAO) Very Large Array (VLA) (see Napier et al. 1983) for which the instantaneous Fourier plane coverage is good and is improved by Earth rotation. In the case of the VLA, the elements are constrained to lie along straight lines by the waveguide used for signal transmission. As long as the light can be interfered coherently, the elements may be an arbitrarily large distance apart. As an example, figure 3 shows the NRAO Very Long Baseline Array (VLBA) now under construction. For the VLBA, signal transmission is accomplished using tapes to limit the layout principally by geography.

There are two major changes in array layout on going to optical wavelengths. First, as discussed above, it becomes advantageous to limit the number of interferometers operating simultaneously since the SNR degrades as the light is divided. The requirement to measure closure phase (see the next section) drives the optimum number of elements to about five or six. Second, since the atmospheric coherence time (~ 10 ms) is much shorter than the time for the source coherence to change due to Earth rotation (min), and since most imaging requires good SNR within an atmospheric coherence time, it becomes worthwhile to move the antenna every 10 min or more frequently to improve the sampling of the Fourier plane. At optical wavelengths, one therefore prefers a small number of easily movable elements.

Imaging

Once samples of the coherence function have been collected, edited, and calibrated, an image can, in principle, be formed by direct Fourier inversion. However, in practice, two generic problems afflict the measured coherence function: first, the sampling is often incomplete and, second, the calibration of the coherences may be uncertain because of the effects of the Earth's atmosphere or uncertainties in the geometry of the interferometer. The first problem may be addressed using deconvoluted algorithms, which can use a priori information about the sky's brightness to interpolate missing values of the coherence function. Examples of such algorithms are CLEAN (Hogbom 1974), the Maximum Entropy Method (Narayan and Nityananda 1986), and the Gerchberg-Saxton-Papoulis algorithm (Papoulis 1975).

The second problem is of varying importance in different applications. A good rule of thumb is that for wavelengths shorter than about 30 cm (including IR and optical), imaging at better than arcses resolution requires some countermeasures to the neutral atmosphere (Woolf 1982). In other regimes, countermeasures are necessary for high-quality imaging. The geometric uncertainties are worst for long baselines (note the similarity to the problem of figuring a single aperture). Most of the effective techniques are related to the concept of closure phase introduced by Jennison about 30 years ago (Jennison 1958). Since calibration errors are predominantly associated with the interferometer elements, rather than pair of elements, a sum of the observed coherence phase around any closed loop of interferometers will be invariant to those errors. To clarify this, note that the coherence phase measured between elements i and j , $\theta_{i,j}$, is related to the true coherence phase, $\hat{\theta}_{i,j}$:

$$\theta_{i,j} = \hat{\theta}_{i,j} + \phi_i - \phi_j \quad (3)$$

where ϕ_i is the phase error associated with the i th element, and I have ignored additive noise. Jennison's sum of the phase around a loop, the "closure phase" Φ_{ijk} , is defined as:

$$\Phi_{ijk} = \theta_{i,j} + \theta_{j,k} + \theta_{k,i} \quad (4)$$

The true closure phase follows a similar definition:

$$\hat{\Phi}_{ijk} = \hat{\theta}_{i,j} + \hat{\theta}_{j,k} + \hat{\theta}_{k,i} \quad (5)$$

Hence we have that the true and observed closure phrases must be equal, no matter what values may be taken on by the phase errors θ .

$$\Phi_{ijk} = \hat{\Phi}_{ijk} \quad (6)$$

A similar observable can be derived for the coherence amplitudes (Smith 1952; Twiss et al. 1960). High-resolution imaging, therefore, uses these closure quantities rather than the observed coherences as constraints on the final image. As a result, high-quality imaging of complex objects is possible even in the presence of severe phase errors due to the atmosphere (Pearson and Readhead 1984) or in the case where the interferometer geometry is not accurately known (Schwab and Cotton 1983). While these techniques were first developed in the radio regime, they have recently been demonstrated in high resolution optical imaging (Haniff et al. 1987). Indeed, while the details of imaging vary with wavelength, the general principles remain the same, so much so that one software package will suffice for most interferometric imaging.

References

1. Haniff, C.A.; Mackay, C.D.; Titterton, D.J.; Sivia, D.; Baldwin, J.A. 1987. *Nature* 328:694.
2. Hogbom, J.A. 1974. *Astrophys. J. Suppl.* 15:417-426.
3. Jennison, R.C. 1958. *Mon. Not. R. Astr. Soc.* 118:276.
4. Napier, P.J.; Thompson, R.T.; Eckers, R.D. 1983. *Proc. IEEE* 71:1295.
5. Narayan, R.; Nityananda, R.; 1986. *Ann. Rev. Astron. Astrophys.* 24:124-170.
6. Papoulis, A. 1975. *IEEE. CAS-22*:735-742.

7. Pearson, T.J.; Readhead, A.C.S. 1984. *Ann. Rev. Astron. Astrophys.* 22:97-130.
8. Ryle, M.; Hewish, A. 1960. *Mon. Not. R. Astro. Soc.* 120:220-230.
9. Schwab, F.R.; Cotton, W.D. 1983. *Astron. J.* 88:688.
10. Smith, F.G. 1952. *Proc. Phys. Soc. B* 65:971.
11. Thompson, A.R.; Moran, J.M.; Swenson, G.W. 1986. *Interferometry and Synthesis in Radio Astronomy.* Wiley Interscience.
12. Twiss, R.Q.; Carter, A.W.L.; Little, A.G. 1960. *Observatory* 80:153.
13. Woolf, N.J. 1982. *Ann. Rev. Astron. Astrophys.* 20:367.

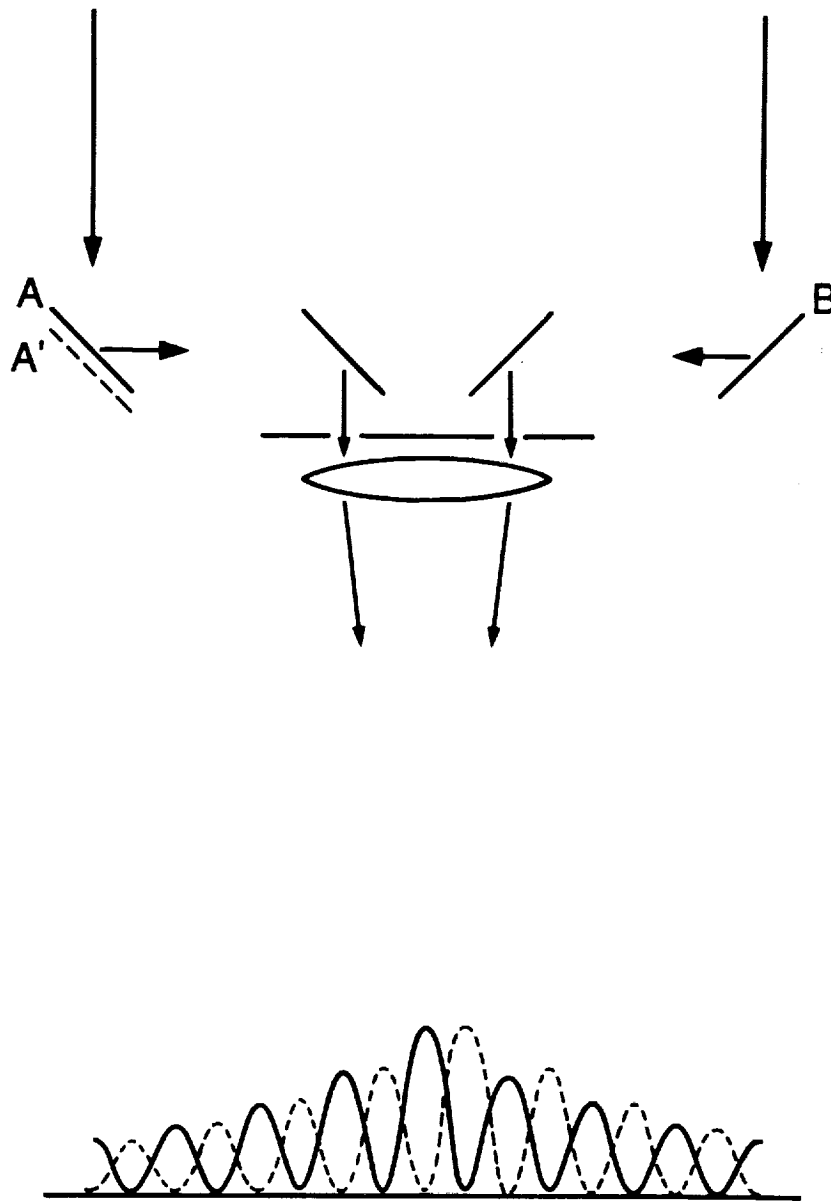

Figure 1: Schematic of a Michelson interferometer. The light reflected from the two outer mirrors produces interference fringes at the focus. The contrast and position of the fringes yield information about the source structure. The fringe position is best measured at optical wavelengths by modulating the position of one mirror (A to A').

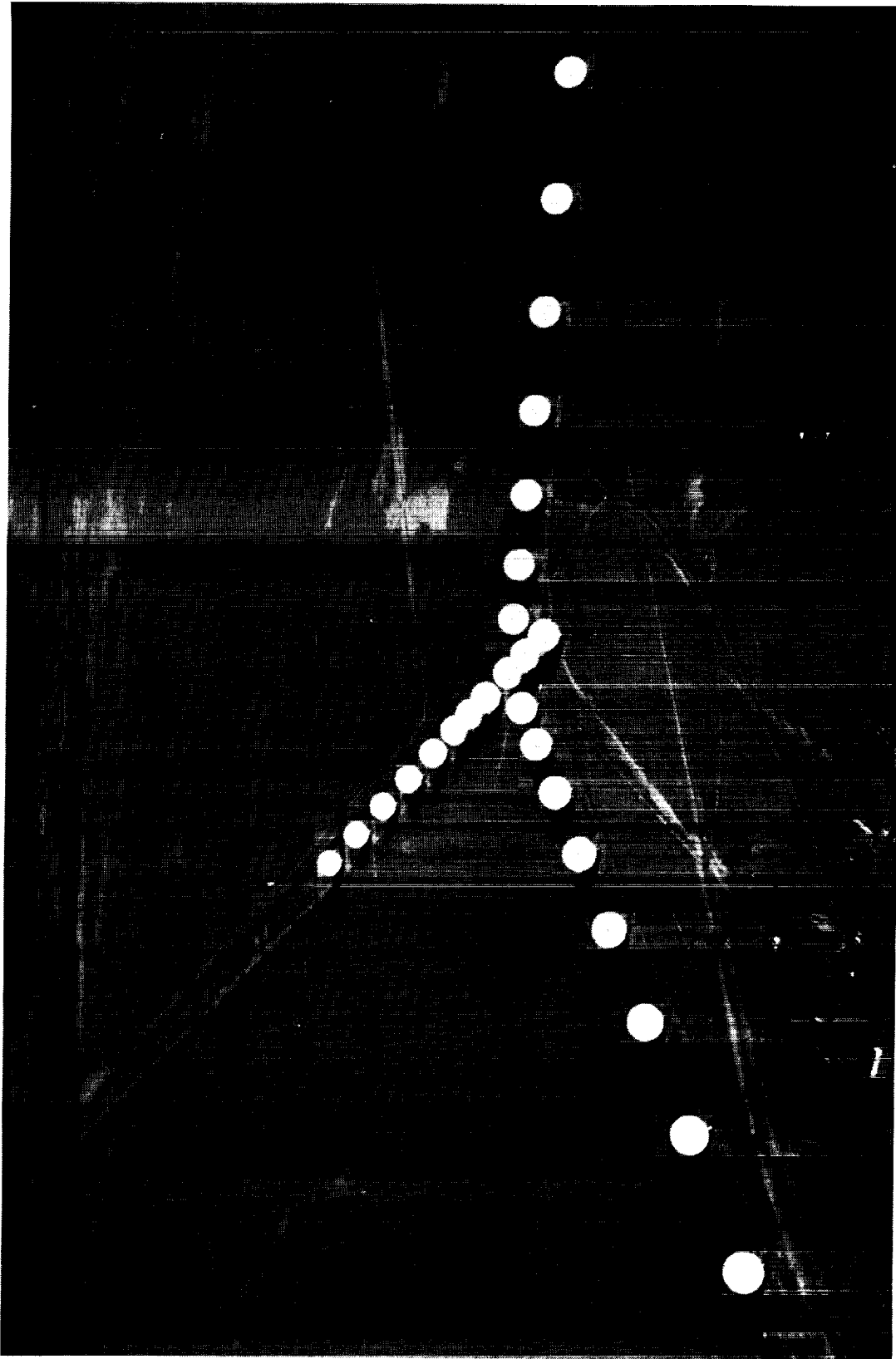

Figure 2: The National Radio Astronomy Observatory Very Large Array near Socorro, New Mexico. The VLA consists of 27 antennas located on a Y-shape which is reconfigurable to give baselines ranging from 40 m to 35 km. Observing wavelengths are 4 m, 90 cm, 21-18 cm, 6 cm, 3.6 cm, 2 cm and to 1.3 cm.

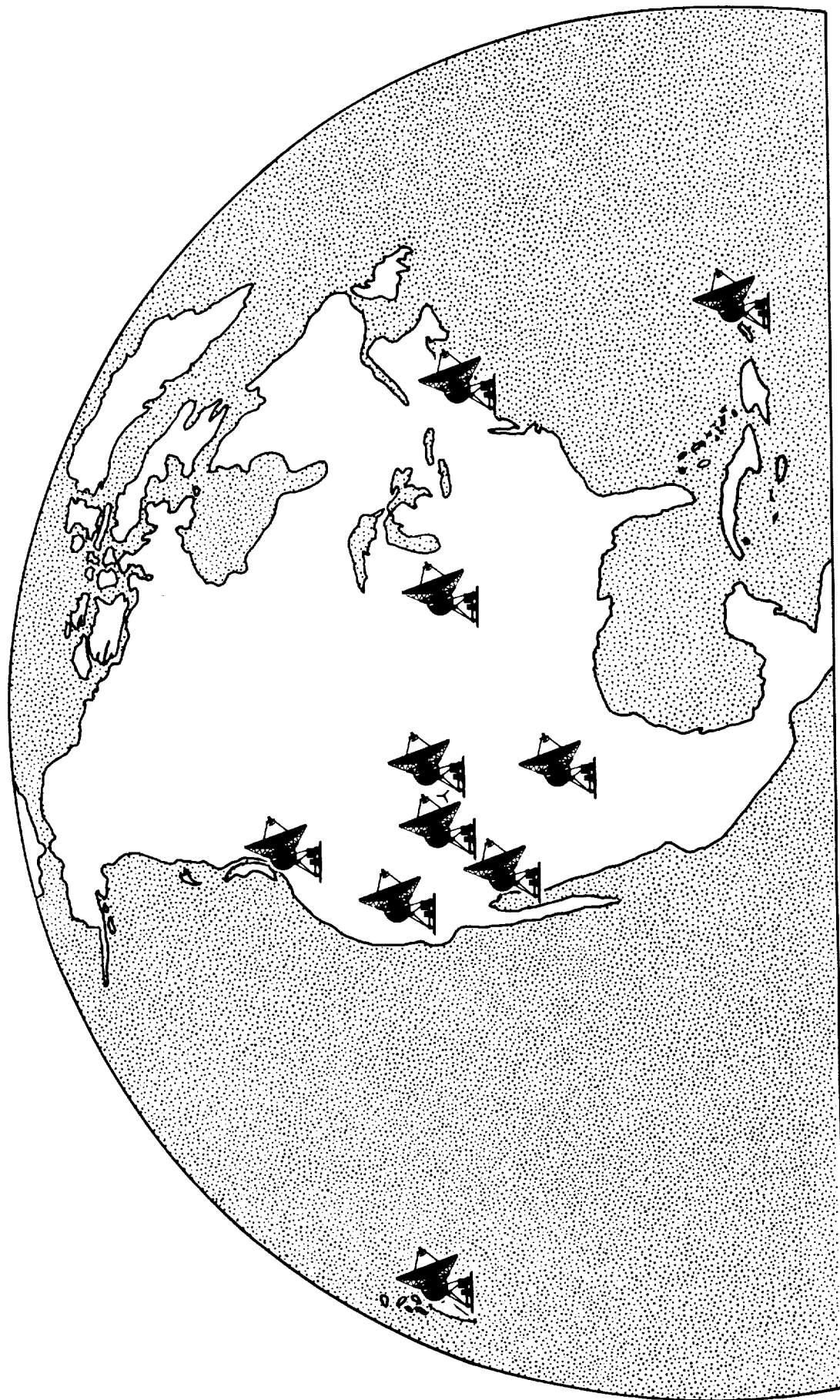

Figure 3: The NRAO Very Long Baseline Array will provide a dedicated array for very high-resolution imaging at radio wavelengths. The maximum baseline is fixed at about 8000 km.

PART II
GROUND-BASED OPTICAL AND INFRARED INTERFEROMETERS

The papers in this section describe the impressive advances made in recent years in ground-based optical and near-IR interferometers. The technologies described in these papers are keys to the successful establishment of a synthetic aperture telescope on the Moon.

H.A. McAlister begins by describing the CHARA Optical Array constructed and operated by Georgia State University. K.J. Johnston and colleagues then discuss the technical status and recent astrometric measurements from the Mount Wilson Optical Interferometer run by NRL. A. Labeyrie presents a discussion of the Optical Very Large Array currently under development in Europe and its possible extension to a lunar-based interferometer. S.R. Kulkarni next describes high-resolution imaging at Mt. Palomar using Non-Redundant Masking and Weigelt's Fully Filled Aperture methods. An infrared (9-12 microns) spatial interferometer using Earth rotation aperture synthesis techniques developed at Berkeley is described by W.C. Danchi and colleagues. The final paper in this section, by S. Prasad, discusses the shot-noise limits to sensitivity of optical interferometry, an important topic debated extensively at the workshop.

THE CHARA OPTICAL ARRAY

Harold A. McAlister

Center for High Angular Resolution Astronomy
Georgia State University
Atlanta, GA 30303-3083

Introduction

The Center for High Angular Resolution Astronomy (CHARA) was established in the College of Arts and Sciences at Georgia State University in 1984 with the goals of designing, constructing, and then operating a facility for very high spatial resolution astronomy. The interest in such a facility grew out of the participants' decade of activity in speckle interferometry. Although speckle interferometry continues to provide important astrophysical measurements of a variety of objects, many pressing problems require resolution far beyond that which can be expected from single aperture telescopes. In early 1986, CHARA received a grant from the National Science Foundation which has permitted a detailed exploration of the feasibility of constructing a facility which will provide a hundred-fold increase in angular resolution over what is possible by speckle interferometry at the largest existing telescopes. The design concept for the CHARA Array was developed initially with the contractual collaboration of United Technologies Optical Systems, Inc., in West Palm Beach, Florida, an arrangement that expired in August 1987. In late November 1987, the Georgia Tech Research Institute joined with CHARA to continue and complete the design concept study.

The design philosophy has been to specify an interferometric array which incorporates as much off-the-shelf technology as possible and which is capable of making frontier contributions to modern astrophysics. This paper is not intended as a presentation of scientific potential, but two applications in stellar astrophysics clearly indicate the power of distributed arrays. Speckle interferometry at the largest telescopes can now resolve binary star systems with periods of the order of 1 to 2 years and is limited to five or six resolvable supergiant stars. The CHARA Array will be capable of resolving spectroscopic binaries within a few hours. Several hundred thousand stars of all spectral types and luminosity classes will be accessible to diameter measures. Such gains in power by any technique offer the even more exciting aspect of scientific discovery which

cannot be anticipated but which, in retrospect, may be the hallmark of the greatest accomplishment by such a facility.

Much of this science can be obtained by strictly interferometric applications of the array while other problems are best approached through imaging. Current activities by several groups around the world are likely to significantly enhance the maturity of imaging methods by the time the CHARA Array is operational. Thus, while the CHARA Array will immediately provide a wealth of fundamentally important images of astrophysical objects of simple geometry, it will also serve as an important facility for the development and use of imaging algorithms applied to more complex objects.

Very high-resolution imaging at optical wavelengths is clearly coming of age in astronomy. The CHARA Array and other related projects will be important and necessary milestones along the way toward the development of a major national facility for high-resolution imaging--a true optical counterpart to the Very Large Array. Ground-based arrays and their scientific output will lead to high resolution facilities in space and, ultimately, on the Moon.

Description of the Array

The CHARA Array will consist of seven 1-m aperture-collecting telescopes in a Y-shaped configuration contained within a 400-m diameter circle. Each telescope beam is relayed to the central station by a separate light pipe so that all seven beams are simultaneously accessible. At the nominal operating wavelength of 550 nm, the Array will achieve limiting resolutions of 0.35 milliarcsec (mas) for single objects and 0.15 mas for binary stars. Uniform and extensive, two-dimensional coverage of the uv plane beyond that which is provided by Earth rotation has been considered essential to many of the scientific goals of the array. It is also considered essential that a high degree of data throughput be maintained to respond to the very large number of potentially resolvable targets. The seven telescopes simultaneously provide 21 baselines to enhance throughput. The proposed array configuration is shown in figure 1 while the uv coverage obtained at $\delta = +20^\circ$ during 1 hour of diurnal motion is shown in figure 2.

Telescope apertures and mountings are important cost drivers. Apertures of 1 m were selected as offering several important advantages. At 2.2 μm , the longest wavelength at which the CHARA Array is intended to be operated, 1 m is likely to be the largest aperture which is fully coherent for a short, yet significant, period of time. At visible wavelengths, this aperture also

provides a reasonable level of complexity in terms of the adaptive optics needed to correct the incoming wavefront. Smaller apertures, even when made fully coherent by adaptive optics, are not likely to collect sufficient photons to reach even the brightest quasi-stellar objects (QSO), and require longer integration times to reach a particular limiting magnitude, an important throughput consideration. The optical systems will be fast confocal paraboloids to provide an afocal beam, and the telescope mounts will be compact alt-az structures using five mirrors to inject the beam into the light pipe.

A simplified schematic view of the optical path from collecting telescopes to the central beam-combining station is shown in figure 3 for two telescopes. The various subsystems encountered along this path are briefly described in the following paragraphs.

Adopting a 100-cm aperture for the afocal collecting telescopes, a beam reduction factor of five provides collimated beams 20 cm in diameter which must be relayed to the central beam-combining station over path-lengths as long as 200 m. The #5 mirror in a light-collecting telescope must, therefore, accommodate critical pointing conditions to keep the beam from wandering by more than 2 mm when it strikes the #6 mirror in the beam directing periscope system.

The compressed beams from the collecting telescopes will be relayed to the central station through evacuated light pipes to eliminate the potentially severe effects of ground-level turbulence and to minimize the cumulative spectral dispersion that would result from these long air paths. Each of the collecting telescopes will have a dedicated light pipe, a necessity if all beams are to be simultaneously available at the central station. At the exit end of the vacuum pipes, the beams will encounter two-mirror periscopic alignment systems. These mirrors, #6 and #7 in figure 3, serve the purpose of placing all seven beams in a parallel configuration to be fed to the path-length compensation system. It can be shown that there is no differential field rotation among the beams when all telescopes are pointed at the same object. The absolute field orientation can easily be calculated for each pointing.

Of critical importance to the success of an astronomical interferometer is the performance of the system designed to compensate for the variable optical path-lengths from the collecting telescopes to the central station. Each collecting telescope will feed light to a dedicated optical path-length equalizer, or OPLE, system. The OPLEs need not be equal in length. The placement of the collecting telescopes in the array configuration shown in figure 1, combined with a typical

maximum zenith angle of 55° and a maximum integration time between baseline resettings of 1 hour, can be used to constrain the relative lengths and placements of the individual OPLE lines. To meet optical coherence length requirements, the OPLE must provide an absolute path-length equality of $2 \mu\text{m}$ over a range of 70 m and must be free of jitter in excess of $\pm \lambda/20$ during a 10 msec time frame. Relaxation of these specifications could occur if a passband narrower than the nominal 8 nm or a shorter time frame were used.

The OPLE concept for the CHARA Array, as shown schematically in figure 4, calls for the movement of a cart along parallel rails assembled from 20-foot lengths of precision rail. The dowelled joints between successive rails are ground to keep joint discontinuities at less than 0.0001 in. The velocity and position of the retroreflector cart are controlled by a micro-stepper motor servoed to a control signal generated by a laser interferometer. The absolute position and velocity at any instant for a particular pointing will be determined by a computer-generated model which will be improved through a learning process based on actual experience.

The retroreflector system will be a catseye using 61 cm parabolic primary optics and 21 cm flat secondaries. The control system for the OPLE is essentially that of the very successful SAO/NRL Mark III stellar interferometer, in which a hierarchical division of control signals is distributed to the stepper motor for the lowest frequency, highest amplitude corrections, to a speaker coil driving the mounting of the flat secondary in the catseye system for intermediate frequencies and amplitudes, and to a PZT stack which directly actuates the secondary reflector for the highest frequency and lowest amplitude corrections. Computer control of the servo tasks enables the PZT and voice coil servos to operate at 1 kHz. Preset fiducials along the track can be set with precisions of $\pm 1 \mu\text{m}$ using magnetic sensor devices.

The emergent beam from an OPLE is directed by mirror #10 toward an optical table on which are mounted the optical systems used for the next stage of beam compression. These systems will be afocal, using confocal paraboloid primary (mirror #12) and secondary (mirror #13) mirrors to reduce the beam by another factor of five to give an output beam diameter $\leq 1 \text{ cm}$. As can be seen in figure 5, the output from these beam-reducing telescopes goes to two subsystems: the first for guiding, and the second for relaying light to the auxiliary spectrograph. Convenient access is also given to the central obscuration of a beam prior to reduction. Figure 5 shows how this access can be used to insert a laser metrology beam into the system and pick off light to be used to align mirrors #5 through #10.

The goal of the laser metrology subsystem is to measure the path-length from the #1 mirror, i.e., the primary mirror of a light-collecting telescope, to a fiducial on the optical table containing the beam reduction optics. Presently available laser interferometers easily provide the desired accuracy but lack the range needed in this application. A two-color laser system developed for the University of Sydney Large Stellar Interferometer, with even longer path-lengths than the CHARA Array, could accomplish this function. A possible substitute would be the use of electronic distance meters commercially available for surveying purposes. These devices are becoming available with precisions of ± 0.5 mm, although they remain rather expensive. The purpose of this metrology would be to permit rapid accommodation for path-length drifts to quickly meet the coherence requirements and to quickly acquire fringes on new targets. It is expected that such effects, which may be tied to meteorologically induced relative motions between the collecting telescopes and the central station, are repeatable and can be mapped out. Therefore, this type of metrology would only be required to produce the mapping look-up tables which would be updated for secular changes.

The beam alignment subsystem uses a simple scheme in which LED's are mounted in the centers of mirrors #4 through #9. When the LED on mirror $n-1$ is illuminated, the orientation of mirror n can be adjusted to center the point source in the field of a small CCD camera mounted at the focus of the beam alignment telescope. By working out from the beam alignment telescope to the #5 in a kind of "airport landing light" approach, easy alignment can be obtained and checked as necessary.

The guider subsystem will incorporate a beam splitter to extract approximately 10 percent of the light from the object to illuminate a guider sensor, possibly a quadrant type detector or an avalanche photodiode system. The servo system will use the low frequency, large amplitude corrections in a closed loop to the collecting-telescope drives and the high-frequency residual errors to correct for average atmospherically induced tilt by actuating a PZT-driven tilt corrector mirror on the optical table. The beam folding correction provided by mirrors #13 (the tilt corrector) and #14 (a fixed flat) provides for nearly normal incidences while keeping the beams parallel to their original directions.

The first approach at beam combination, as shown in figure 6, uses a system of fixed flats and beam splitters to equally separate each of the seven beams into pairs of beams. A similar arrangement of fixed flats which incorporates beam splitters movable on precision shuttles to

preset locations then provides a means for interfering any beam with any other beam. The fixed relative optical delays can be minimized by appropriately laying out this subsystem and the OPLEs. This arrangement provides an easy means for quickly changing baselines, an activity which is mostly dominated in time by the slewing of the OPLE retroreflectors. Slightly more complicated schemes for combining beam triplets for closure phase imaging can easily be configured.

Pupil-plane interferometry offers a wide variety of approaches to detection and analysis. This is an area in which the 0th-order approach will be a straightforward imaging of the interfered pupil planes in a single bandpass onto an array detector. A single detector will provide a sufficient number of pixels so that the two sets consisting of seven interfering pupils each can be accommodated by two detectors. To adequately resolve the pupil-plane intensities, 16 pixels across a pupil would be necessary. Thus the array detector would have a minimum of $256 \times 7 \times 2 = 3584$ pixels. In addition, the output for several other passbands can be located on the same detector, including a wide passband for fringe-tracking.

This detector hardware implementation or "strategy" is a straightforward extension of that used by the University of Sydney for a single r_o system. As additional advantages, it has the ability to vary the detector "footprint" (areas over which photons are counted in computing visibilities) in software and, thus, to obtain an internal estimate of visibility loss due to the finite detector areas.

Several other detector strategies were considered. One is to use footprints with the light fed into 100 to 200 fibers, re-arranged linearly, and then dispersed spectrally to produce visibilities from the fringes. A second is to rely on a higher degree of compensated imaging and to channel the light prior to combining from each aperture into only six fibers, representing six 33-cm sub-apertures. Light from each telescope could thus be combined pairwise with the light from the other six telescopes and then spectrally dispersed. With an even higher degree of compensation, the light from the whole aperture would be used for combination. An evolution in detectors toward the latter detector strategy is envisioned, which would reduce the data burden, increase the limiting magnitude, and facilitate the combining of three or more beams to obtain closure phases for imaging.



Optical Effects and Simulations

Because of the very long light propagation paths in the arms of the interferometer, it was considered necessary to explore the effects of diffraction on visibility measurement. In a series of calculations, the Fresnel approximation to scalar diffraction was carried out to explore the degradation of propagating wavefronts. Of particular concern was the effect of beam reduction on the spread of diffracting waves. For a beam reduction factor of m , these effects were shown to be proportional to m^2 . Thus the natural tendency to reduce the beams immediately to a rather small diameter before relaying them to the central station must be given careful consideration. Simulations incorporating realistic atmospheric turbulence models showed that diffraction leads to a kind of scintillation in the pupils, an effect which mimics the presence of interference, itself, in the pupils. This scintillation does become significant for small, r_0 and long propagation distances and may, in fact, surpass the natural atmospheric effects in degrading visibility.

For reasonable values of r_0 , the loss in visibility over the longest path lengths of the Array was found to become significant for values of $m \leq 0.15$. To ensure a margin of safety, this analysis has led to the adoption of $m = 0.2$ for the CHARA Array. For the CHARA Array, diffraction effects can be expected to reduce visibilities by no more than a few percent over losses arising from natural atmospheric effects.

The oblique 45° reflections from metallic surfaces can produce differential polarization and phase shifts if the sequence of reflections from the telescopes to the combining house is not the same. In the CHARA Array, an asymmetry occurs in the two mirrors (#6 and #7 in figure 3) that translate light from the telescopes to the OPLEs. Polarization effects can be combatted in two ways: first, by adding one or two mirrors to make the sequence of reflections the same for all telescopes or, second, by only using one polarization for visibility measurement. The second polarization can be used for compensation imaging, etc.

To improve the understanding of the performance that can be expected from an interferometric array, an extensive series of simulations has been carried out. These simulations are based on a realistic model of the spectrum of atmospheric turbulence characterized by Fried's parameter r_0 and the wind velocity. The scalar diffraction theory is used to propagate the beams from the collecting telescopes to the plane of interference. Various detection

schemes can be implemented in simulations incorporating wavefront corrections starting with simple tilt compensation and adding high order corrections. This effectively increases r_0 to an appreciable fraction of the aperture. The performance of the array has been evaluated in the high photon flux case as well as in the case of dim objects and for a variety of object types. For example, it has been shown that binary star systems with separations as small as the resolution limit of the array (0.15 mas) can be imaged, using only six baselines, with relative geometric and photometric accuracy comparable to that obtainable from speckle interferometry, a method providing continuous uv coverage. The understanding gained through these efforts makes a substantial case for the feasibility of the proposed array.

The simulations show that a multi- r_0 interferometer working in the pupil plane provides the expected advantages over an image plane interferometer, particularly in the requirements imposed on the detection scheme. Using reasonable performance parameters for the array, we find that the limiting magnitude under typical seeing conditions ($r_0 = 10$ cm) is $m_v = +11.4$ extendable to $m_v = +13.9$ by multiplexing ten 8-nm-wide passbands simultaneously. The use of relatively simple adaptive optics based on 15 actuators for compensated imaging provides up to 2.2 magnitudes of improvement for these two cases. The importance of relatively simple wavefront compensation (i.e., that which requires no more than 10 to 15 actuators) when extending the limiting magnitude to a value permitting detection of extragalactic objects provides a role for the continuing development of such adaptive systems. Such systems are likely to become available at relatively modest expense compared to those now being developed for fully compensated imaging at the largest telescopes and will provide advantages in data reduction and multiple beam combinations for closure phase imaging. But even without compensated imaging beyond simple average tilt correction, these simulations show that the CHARA Array can meet and exceed specifications required to carry out the basic scientific program.

The Array Site

Anderson Mesa, near Flagstaff, Arizona, has been selected as the proposed site for the CHARA Array. A region of the Coconino National Forest has been designated as an astronomical preserve since 1961, when Lowell Observatory negotiated with the U.S. Forest Service for access to a permanent dark site outside of Flagstaff. The "Lowell Use Area" is currently being renegotiated, and new boundary lines are being defined which will more than adequately accommodate the array.

The selection of Anderson Mesa resulted from a detailed site selection process. An initial list of 10 candidate sites was culled to three possible locations following the first evaluation. Other sites which were finally considered in detail were Mt. Fowlkes, adjacent to the Mt. Locke facilities of the McDonald Observatory, and Blue Mesa near Las Cruces, a site developed by New Mexico State University's Department of Astronomy. The process considered a number of parameters judged to be critical to the selection of a site. These parameters included suitability of terrain to a distributed array, meteorological conditions (particularly cloudcover), degree of night sky illumination, geology (particularly seismic background level), atmospheric seeing, and logistics. As with any astronomical site selection, the accumulation of relevant data is a challenging task due to the heterogeneity of the data types. The one category in which homogeneous data was secured was the question of relative cloudcover. Satellite observations of cloudcover were obtained from the National Climatological Data Center for the southwestern U.S. covering the time interval from January 1984 through September 1987. These data showed, somewhat to our surprise, that northern Arizona offered the clearest skies during this time period.

Probably the most critical of the above issues is the question of seeing conditions at a variety of candidate sites. To provide measurements of seeing on Anderson Mesa, the only one of our candidate sites which had never been evaluated for seeing, an inexpensive seeing monitoring system was assembled from a commercial CCD video camera system and PC-based frame grabber board. Tests with this system during the spring of 1988 permitted the tie-in to a more extensive series of seeing measurements carried out from the U.S. Naval Observatory (USNO) Flagstaff Station. The mean seeing on Anderson Mesa during this period was 1.24 arcsec, and we expect that the Mesa will exhibit long-term seeing similar to that of the USNO station. Considering the conditions at Anderson Mesa, we can expect median FWHM seeing profiles of 1.1 to 1.2 arcsec during 30 percent of all nights. We can also expect the poor seeing tail to yield seeing worse than 2.0 arcsec for another 30 percent of the time. Thus, while Anderson Mesa does not compete with Mauna Kea in the category of superior seeing, it can be expected to provide very acceptable seeing conditions in addition to the very favorable ratings in other categories.

Conclusion

A feasibility study and an initial design concept have been completed for a multiple telescope array for very high spatial resolution astronomy. The success of current programs in

long-baseline optical interferometry and the development of critical technology as a result of these efforts argue strongly for increased activity in this field.

The CHARA Array will be open to visiting astronomers from other institutions who can conduct their own scientific programs or develop alternative detection and analysis schemes. The facility's role of serving as a test bed for the development of imaging techniques and auxiliary instrumentation, such as compensated imaging devices, will allow it to play a dynamic role in the continuing development of high resolution imaging with national and international participation.

Acknowledgments

This project has been a collaborative effort with the major participation of William G. Bagnuolo, Jr., and William I. Hartkopf. We plan to publish more detailed reports of the various aspects of this study. The National Science Foundation provided major support for this effort through NSF Grant AST 84-21304, and we gratefully acknowledge this critical support.

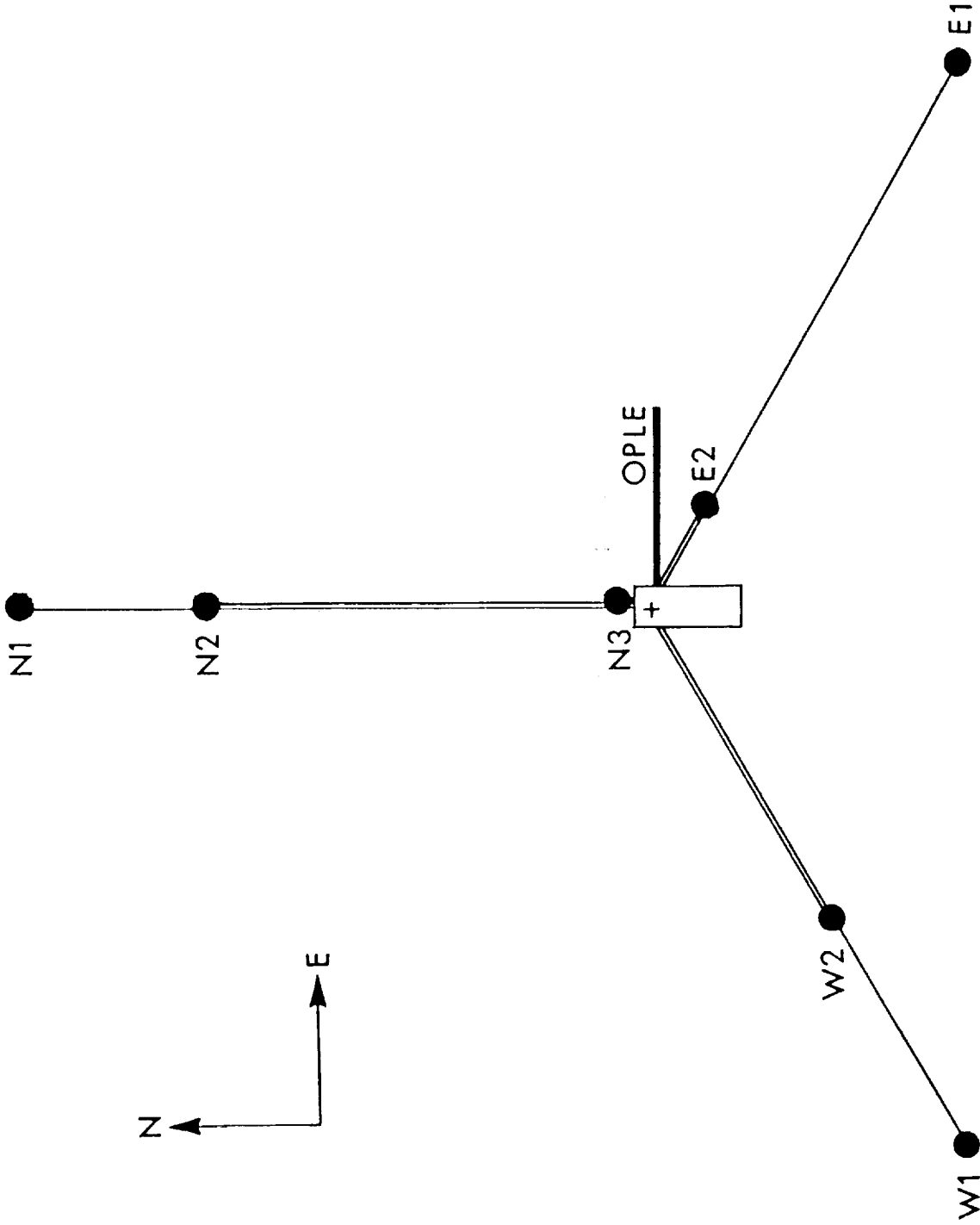

Figure 1: The baseline configuration for the CHARA Array is shown. The three telescopes at the extreme limits of the array are 200 m from the central station.

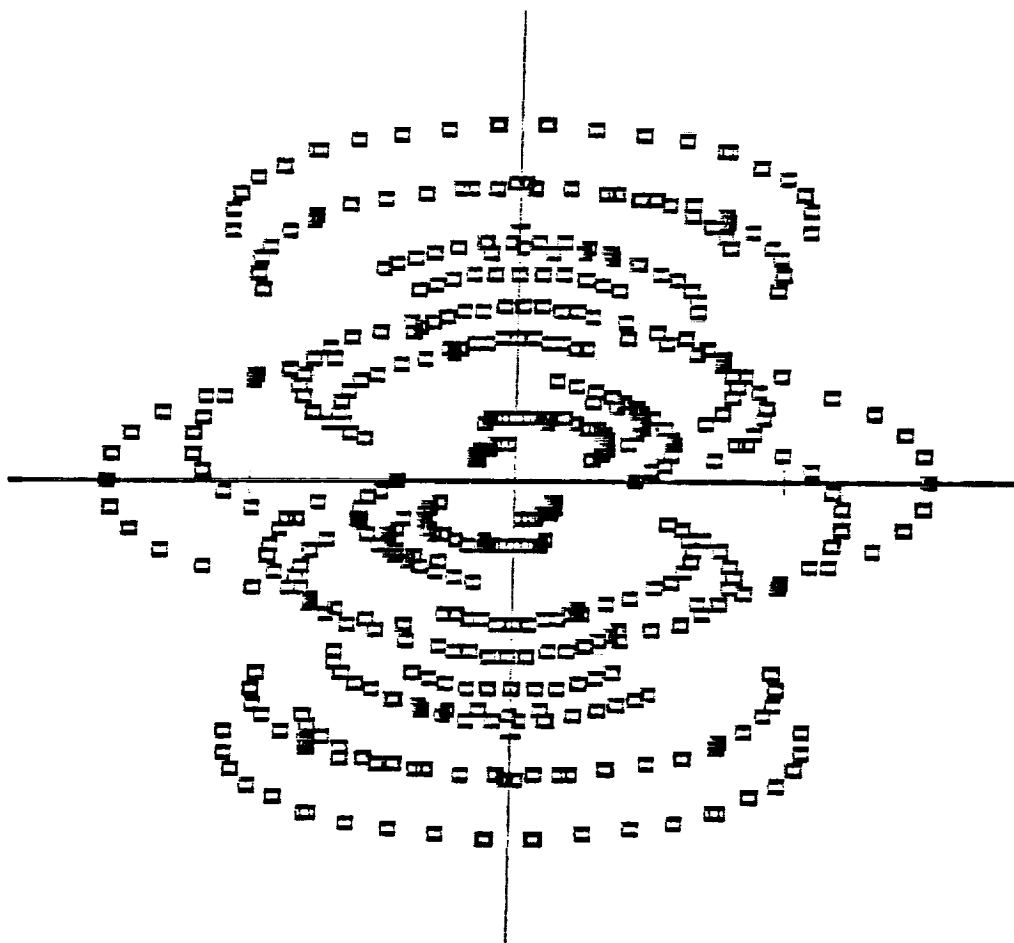

Figure 2: The uv coverage for the selected array is shown for the case of $\delta = +20^\circ$ after 1 hour of Earth rotation induced synthesis.

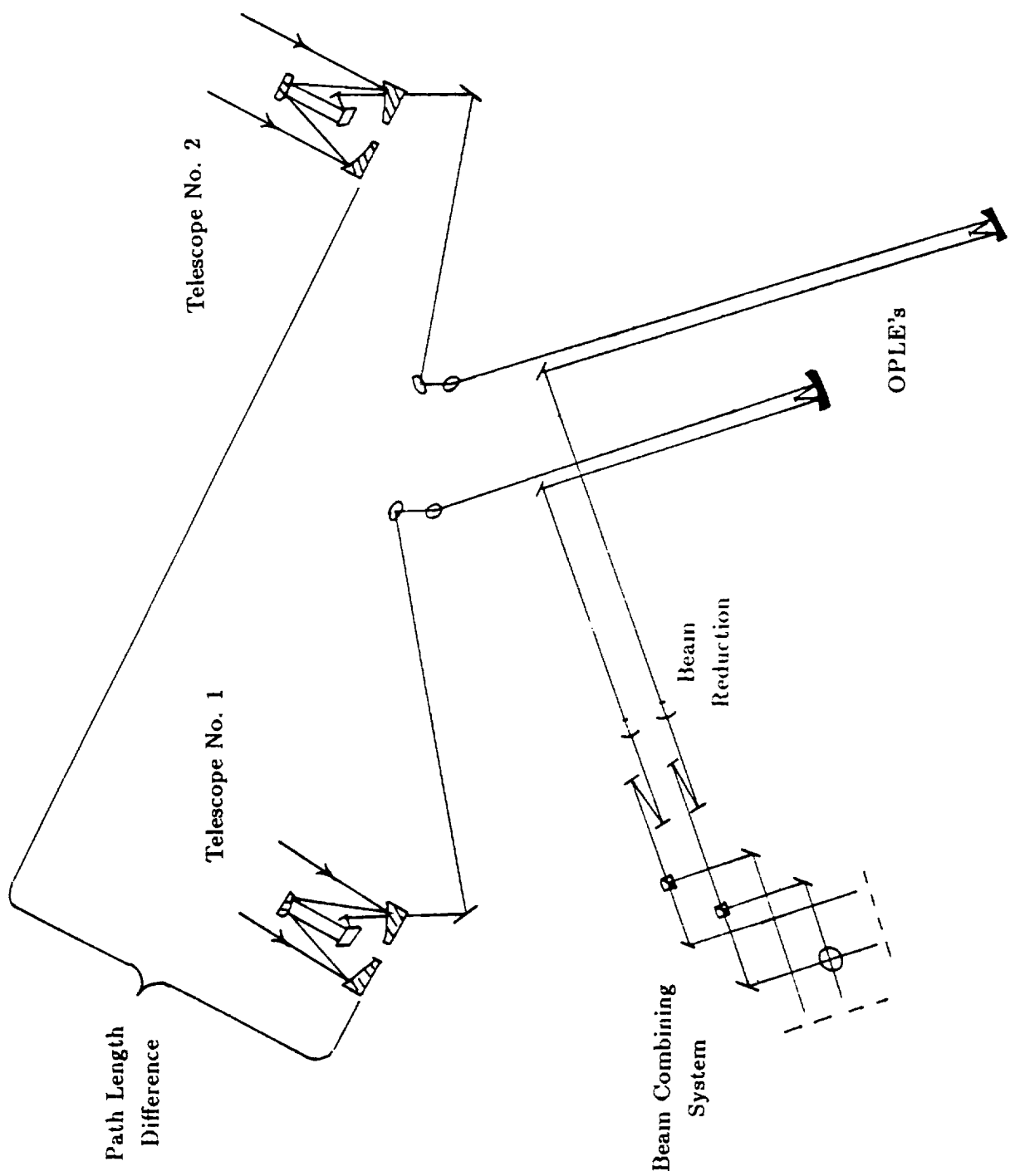

Figure 3: The simplified overall optical layout of the CHARA Array is shown for two collecting telescopes.

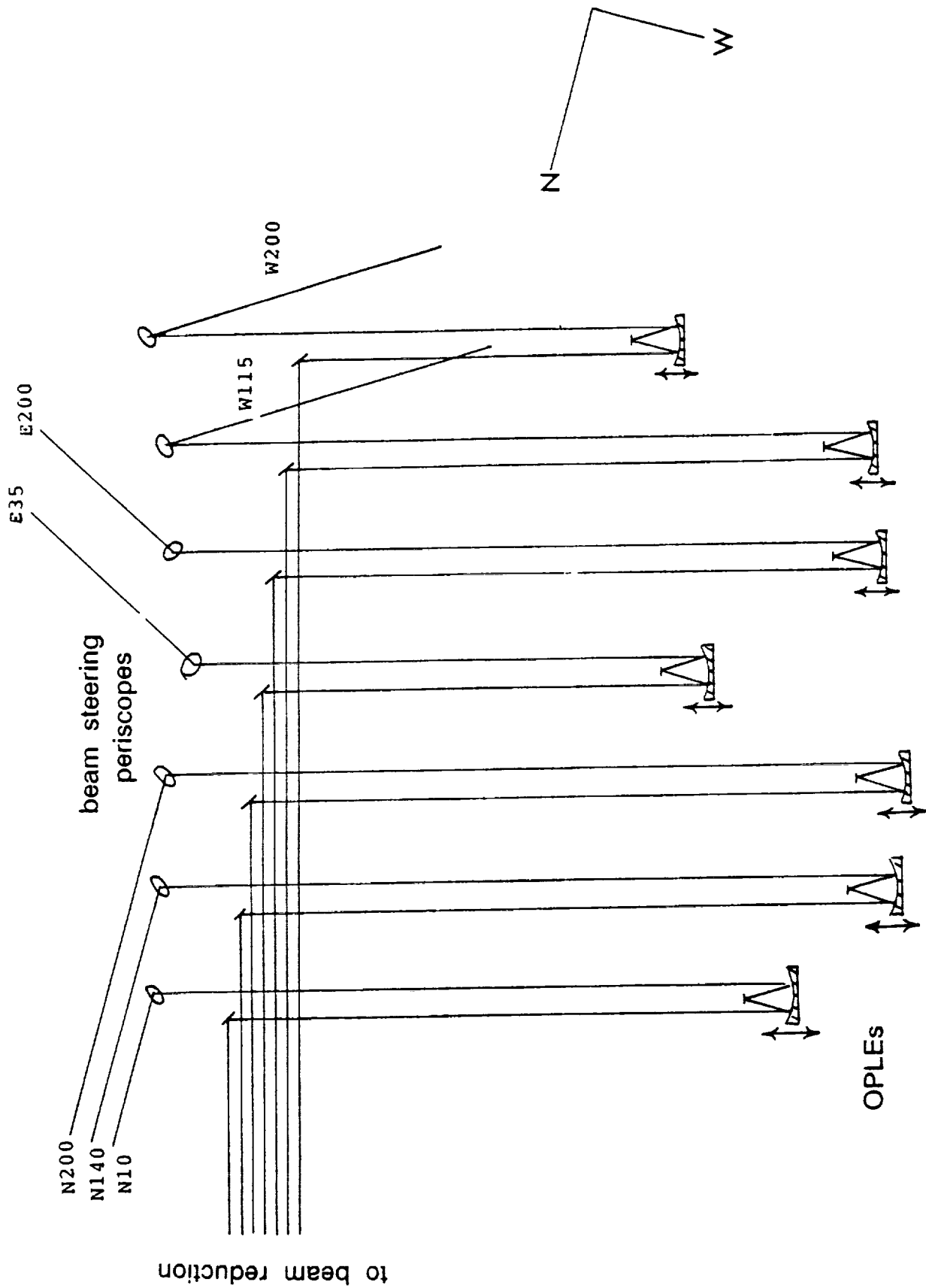

Figure 4: The path length compensation subsystem is shown for all seven telescopes including the insert periscopes for aligning the beams and the #10 mirrors which relay the beams from the OPLEs to the beam combining table.

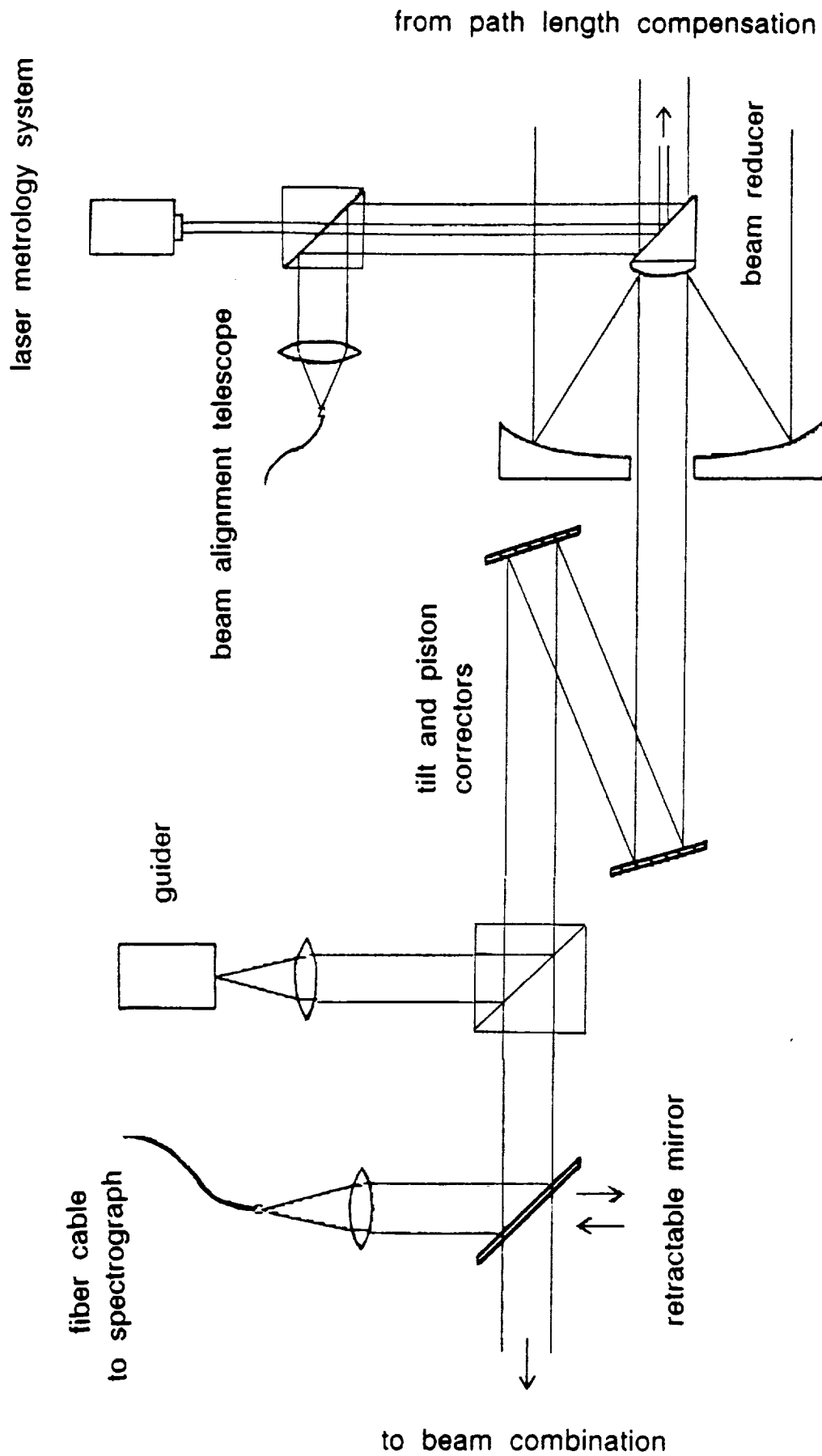

Figure 5: The beam reduction and guiding subsystems are shown for a single light-collecting channel.

from beam reduction
and guiding system

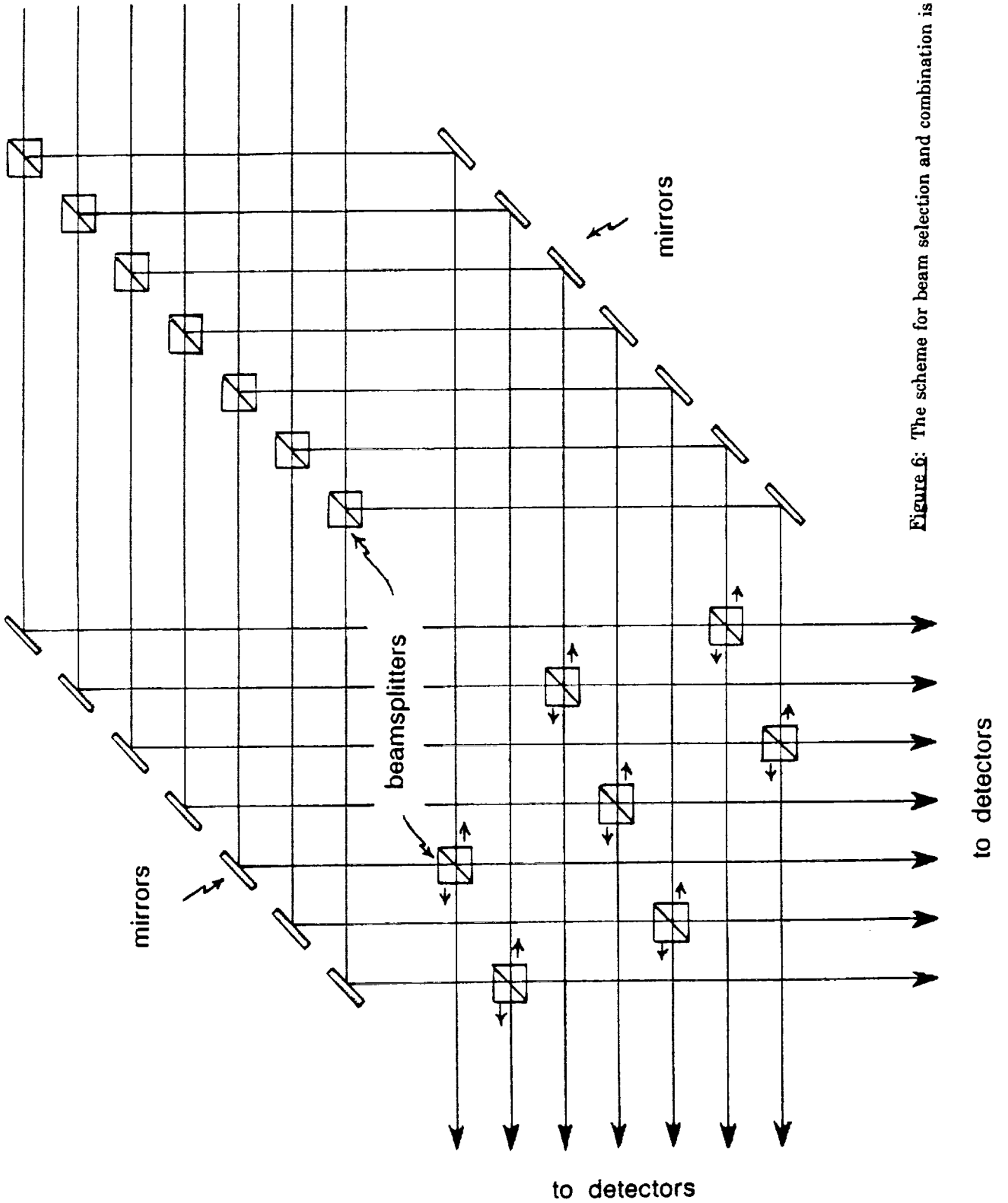

Figure 6: The scheme for beam selection and combination is shown.

THE MOUNT WILSON OPTICAL INTERFEROMETER:

THE FIRST AUTOMATED INSTRUMENT
AND THE PROSPECTS FOR LUNAR INTERFEROMETRY

K.J. Johnston, D. Mozurkewich, R.S. Simon

E.O. Hulburt Center for Space Science
Naval Research Laboratory
Washington, DC 20375

M. Shao, M. Colavita

Smithsonian Astrophysical Observatory
Cambridge, Massachusetts

Introduction

Before contemplating an optical interferometer on the Moon one must first review the accomplishments achieved by this technology in scientific applications for astronomy. This will be done by presenting the technical status of optical interferometry as achieved by the Mount Wilson Optical Interferometer. The further developments needed for a future lunar-based interferometer will be discussed.

Background

Long Baseline Optical Interferometry (LBOI) is the use of discrete elements to obtain the detailed spatial structure of celestial objects. The light received from two independent apertures is brought together with the light paths being made equal through the use of a delay line or correcting plate as shown in figure 1. The first known successful application of LBOI to measure the diameters of stars was accomplished by A. Michelson in 1920 with the successful measurement of the diameter of Betelgeuse. This was done using mirrors mounted on a 20-ft beam placed on the 100-in. Mount Wilson telescope. The diameters of six stars, all giants and supergiants of late spectral class, were measured. This interferometer was abandoned because it was too difficult to stabilize the light paths. In 1960, R. Hanbury Brown developed the technique of intensity

interferometry with which the diameters of 32 bright blue stars were measured. In the 1970s, Labeyrie directly combined the light beams from two telescopes. He obtained fringes on Vega with a 12-m baseline using the I2T interferometer. These instruments all used the visibility of the crosscorrelated signal to determine the diameters of stars. The crosscorrelated signal is a complex number containing not only the visibility or amplitude but also phase. The phase gives detailed positional information on the source of the signal.

In 1968, R. Hanbury Brown stated that Michelson's interferometer, or one in which the signals are mixed before detection, is applicable to many astronomical problems but technical problems remained. To produce significant results, the separation must be considerably larger than the 20-ft baseline originally used by Michelson, the instrument must be free from errors due to atmospheric seeing, and the results must be recorded in some objective way which is independent of the skill of the individual observers.

The sensitivity of an interferometer is proportional to the optical bandpass, the area of the collecting aperture, and the length of the coherence integration time. The diameter of the collecting aperture is limited to approximately 10 cm for one arcsec seeing by the spatial coherence of the Earth's atmosphere at optical wavelengths (5500 Å). That is to say that the randomness of the turbulence in the atmosphere leads to randomization of the phase on a single aperture or mirror over a spatial distance greater than 10 cm. Similarly the coherent integration time is also limited to approximately 10. To maximize the sensitivity, wide bandpasses are needed. This in turn results in an interference pattern which is very narrow. This pattern is only a few fringes wide and requires active fringe tracking to maintain coherence in the presence of atmospheric turbulence. This in turn limits the sensitivity of Earth-based interferometers to approximately 10 magnitude (Visual) when only a single atmospheric coherence cell is used.

The Mount Wilson Interferometer

As noted, before 1978 all LBOI used only the amplitude of the crosscorrelated signal. The first phase coherent optical interferometer that recorded the amplitude and phase of the crosscorrelated signal using a phototube, computer, and precise delay line to track the differential atmosphere phase path was developed by Shao and Staelin, who tracked the "white light" fringe of Polaris in 1979. This instrument has been improved by the use of the larger apertures, longer baselines, and wider sky coverage into the Mark II and Mark III interferometers.

Figure 2 shows a schematic diagram of an optical interferometer as embodied in the Mark I-III interferometers. The light from a celestial object in the two arms of the interferometer is brought together at the photomultiplier where, when fringes are observed, there is a maximum in intensity. The major innovation is the dither delay line, which vibrates at a frequency of a kHz with an amplitude of about a wavelength of the light being observed. Once fringes are detected, the dither delay line allows them to be tracked at the ms time scale. This is accomplished also by the precision delay line that can be set to 100 Å accurately and read out to 50 Å accuracy. By varying the delay line, the peak amplitude of the fringe pattern can be scanned, thus compensating for variable path length delays. A computer controls the position of the delay line, finds the maximum in the fringe amplitude, and records the delay, amplitude, and phase of the crosscorrelated signal. Thus the path lengths in the two arms of the interferometer can be made equal and tracked on timescales of ms. Since the timescale for turbulence in the Earth's atmosphere is of order 10 m, the interferometer can compensate for phase fluctuations due to atmospheric turbulence.

In addition to measuring the sizes of stars, interferometry can also precisely measure their positions. The USNO has an active program in astrometry and was seeking new technology to improve the accuracy of the positions of stars. Therefore the development of optical/IR interferometry for astrometry was sponsored by the Office of Naval Research. In 1982, a joint program in optical interferometry aimed at astrometry was undertaken by the Naval Research Laboratory (NRL), the United States Naval Observatory, the Smithsonian Astrophysical Observatory (SAO), and the Massachusetts Institute of Technology (MIT). The result was the Mark III interferometer.

Since the major impetus of the NRL/USNO/SAO/MIT program was primarily astrometry or the precise measurement of the positions of stars, the apertures collecting the light from the stars had to be made to rapidly and automatically switch from star to star in a preprogrammed sequence. This required, aside from pointing the mirrors precisely at the stars, that the finding and tracking of the central fringe also be totally automated.

The Mark III stellar interferometer was built to demonstrate fundamental astrometric measurements. A secondary goal was to initiate a program of accurate stellar diameter measurements leading to an instrument for imaging stars. Since astrometric measurements of high precision require repeated measurements, among the goals of this instrument were that it be

easily operable, reliable and capable of extremely accurate measurements. A number of active subsystems were incorporated into the instrument to achieve these goals. The interferometer can be divided into five major subsystems: (1) a star tracker, (2) the optical delay line, (3) the stellar fringe acquisition and tracking system, (4) a laser metrology system, and (5) the siderostat pointing and control system.

Figure 3 shows the Mark III stellar interferometer, which is located on Mt. Wilson, approximately 80 m east of the 100 in. telescope where Michelson and Pease made the first measurements of stellar diameters. Six and ten meters north, south and east of the central building are located the siderostat piers. In the figure, the siderostats are mounted on the innermost piers. The siderostats are located in huts that provide weather protection for the siderostats. The hinged roofs of the huts swing open for observing. Local seeing effects are reduced by routing the starlight through vacuum pipes from the siderostats into the main building. The main building contains the optics that combine the beams, the delay line, etc. The light is directed into the main building by the flats and is directed by piezoelectrically controlled mirrors toward the vacuum delay line. After reflection by the delay line's retroreflectors, the beams are combined at the beamsplitter. Part of the light is directed into the optical fibers that feed the phototubes and part of it is directed toward the star trackers. The trailer to the left of the main building houses the computers and observers. There are four possible baseline configurations from 8.3 m NE-SW to 20 m N-S as shown in figure 4. Also shown is a 4-30 m variable baseline along a N-S line that is capable of amplitude measurements that can be used to measure stellar diameters and evaluate atmospheric turbulence.

Astrometric measurements have been carried out with this instrument. As already stated, these observations involve observing as large a number of stars as possible to measure the baseline length and solve for the star positions. The number of stars observed is limited by how quickly the siderostats can move from star to star and the integration time of the individual measurements. At the present time it takes about 1 min to move between stars and 1 min to obtain an ample amount of data on the individual star. Figure 4 shows the observed delays as a function of time for the observations made on November 11, 1986, with a 12 m N-S baseline. The delay changes as the orientation of the baseline to the stars varies with the Earth's rotation. Rapid measurements must be made among several stars to determine the baseline length and its orientation as the baseline length drifts by approximately a micron an hour.

Measurements made in the fall of 1986 demonstrated that one-color observations could determine star positions in one coordinate to 20 mas. Measurements made in 1988 in two colors made during six nights of observation using the 12 N-S and 8.3 S-E m baselines of 12 stars displayed a formal accuracy of 6 to 10 mas in both celestial coordinates. It is very difficult to compare the accuracies of these star positions to anything available at the present time. The formal accuracy of the best star positions, i.e., the FK5 catalog, which is a compilation of the best available optical data, is at the 50 mas level at epoch 1988. The positions of these stars were in agreement with the FK5 positions at the 50 mas level for over half the stars. Repeated measurements with the Mt. Wilson instrument will have to be made to ascertain the systematic errors on the optical interferometric measurements.

Stellar diameters have also been measured with this instrument. A 12 m baseline at optical wavelengths has a minimum fringe spacing of 8 mas on the sky. If we consider stars to be spherical, which is a rough first approximation which is probably correct at the few percent level, then a one-dimensional variable baseline can be used to measure stellar diameters. The variable 4–30 m baseline has measured the sizes of about 20 stars as of November 1988. Figure 6 shows the observations for the star alpha Arietes. The least squares fit to the stellar diameter is 6.29 mas with an RMS error 0.12 mas. The dotted lines in figure 6 show the visibility curves for a uniform cylinder having a diameter 0.25 mas larger and smaller than the least squares value.

Observation with the Mt. Wilson interferometer will continue in 1989 to evaluate the effects of the atmosphere over long baselines, extend the measurements of stellar diameters and to repeat the astrometric measurements. Further, this instrument will be used to demonstrate prototype systems for future Earth- and space-based optical interferometers.

Developments Necessary for Imaging

The Mt. Wilson interferometer is a two-element interferometer. It has shown that interferometric fringes can be obtained over baselines of length 5 to 30 m and that the operation of an interferometer can be automated from pointing the telescopes to setting the delay line and phasing the instrument.

For true interferometric imaging of objects at optical wavelengths, three key technologies must be developed: simultaneous combination of beams from multiple elements, longer optical delay lines, and a metrology system to precisely monitor the geometry of the instrument. Longer

delay lines are needed to compensate for the variable arrival of the signals at the apertures if baselines longer than 20 m are to be used. These necessary developments should first be undertaken and proven with a ground-based instrument.

Thus, the next logical step in the development of optical interferometry is to build a ground-based instrument for high angular resolution imaging of stars, stellar systems, and other celestial objects. This instrument will be the highest resolution imaging instrument ever used at optical wavelengths, and will achieve resolutions exceeding even those available from Very Long Baseline Interferometry techniques in the radio in all but the shortest radio wavelengths. This instrument will represent a tremendous advance over any currently existing optical interferometer, offering improvements of a factor of 10 or more in sensitivity, resolution, and imaging speed.

The instrument will be located on a suitable mountaintop where atmospheric conditions will facilitate optimum performance. The overall size will be about 250 m in diameter, with at least six independent telescopes or siderostats forming a reconfigurable array. Light from these telescopes will be combined interferometrically in a central optics laboratory to produce the basic visibility amplitude and phase data used to form images.

The research carried out with such an interferometer will have a profound effect on the technology of imaging objects at great distances and will greatly aid in our understanding of the physical attributes such as size, shape, distance, and mass of celestial objects such as stars. The capability of imaging objects will be at least two orders of magnitude better than the Hubble Space Telescope. This improvement in resolution will allow many important astronomical discoveries to be made.

This interferometer is to be the first to image objects directly at optical wavelengths using both the amplitude and phase of the crosscorrelated signal. Early in the program the technology of simultaneously combining three beams and making phase closure measurements should be accomplished. Later the multiple-element instrument will demonstrate from the ground the capabilities of imaging celestial objects. After this an evaluation of the capabilities of using this technology in a space-based system can be made. The first space-based interferometer will be in Earth orbit but later instruments could be located on the Moon.

Interferometry in Space

The advantage of space-based optical interferometry is freedom from viewing objects through the Earth's atmosphere. For an Earth-based optical interferometer, the sensitivity of the instruments is proportional to seeing to the third power. This allows the phase across the observing aperture to be constant whereas on the Earth, for seeing of order one arcsec, apertures larger than 10 cm cannot be used for a single coherent aperture at 5500 Å. Apertures of size 10 cm must be summed. Further, integration times greater than 10 mas cannot be used (again assuming one arcsec seeing).

Imaging objects on the Earth with a conventional phase-stable interferometer using a single atmospheric coherence cell will be limited to objects brighter than 10th magnitude. If by summing different cells in the Earth's atmosphere increases the collecting area of the interferometer, or if a natural or artificial reference source can be found or generated to increase the integration time, fainter magnitudes can be reached. An interferometer in space will not have this limitation because very large optics can be used. The limitation on the imaging magnitude will be the stability of the space-based platform and the figure and stability of the large apertures. Therefore, for a space-based system, the intrinsic stability of the interferometer or the metrology system, i.e., the system measuring the spatial stability of the interferometer, will set the limiting magnitude constraint.

For free-flying interferometers, the stability of structures in space must be studied and metrology systems must be developed to overcome the shortcomings of the structures. The sizes of stars vary from 60 to 0.1 mas while the size scales of extragalactic objects are of order a few mas or less. This leads to useful baselines at optical wavelengths of order 10 m (10 mas) to 1000 m (0.1 mas) for imaging objects. It is very doubtful that structures as large as 100 m would be built for a free-flying interferometer, thus, for the longer baseline, either multiple free-flying satellites will be used, or the interferometer will be placed on the Moon.

Other reasons for placing an interferometer in space are to improve the instrumental stability and astrometric measurements. A free-flying space astrometric instrument would probably use a very short baseline, but there would be no limit on baseline length for a lunar instrument except that the object not be resolved. For an interferometer based on the lunar surface, the problems of instrumental stability should be simpler because massive structures can be used for stability. Note that the Mt. Wilson interferometer has massive piers which move at about a

micron per hour. Thermal effects should have a much slower timeconstant for a lunar instrument since thermal effects will vary with the lunar rotation period whereas a satellite in earth orbit will have a much shorter thermal period unless it is sun synchronous.

Conclusion

The Mt. Wilson interferometer has demonstrated the necessary technologies of telescope coalignment and optical delay lines. Three further developments in ground-based interferometry are needed before the development of space-based interferometry. These are the simultaneous combination of beams from multiple elements, longer optical delay lines, and a metrology systems to precisely monitor the geometry of the instrument. After these developments take place, the study of space-based structures should be undertaken to evaluate the applicability of Earth-orbiting interferometers. In the long term, optical interferometry will need baseline lengths of order 100 m or greater for imaging and multiple free-flying individual apertures, or a lunar based interferometer must be considered. The technology for a lunar interferometer appears to be close in hand as it is just an extension of the Mt. Wilson interferometer and should require a minimum of technology development. Thus the prospect of a lunar interferometer should be carefully considered when the development of the Moon for scientific purposes is undertaken.

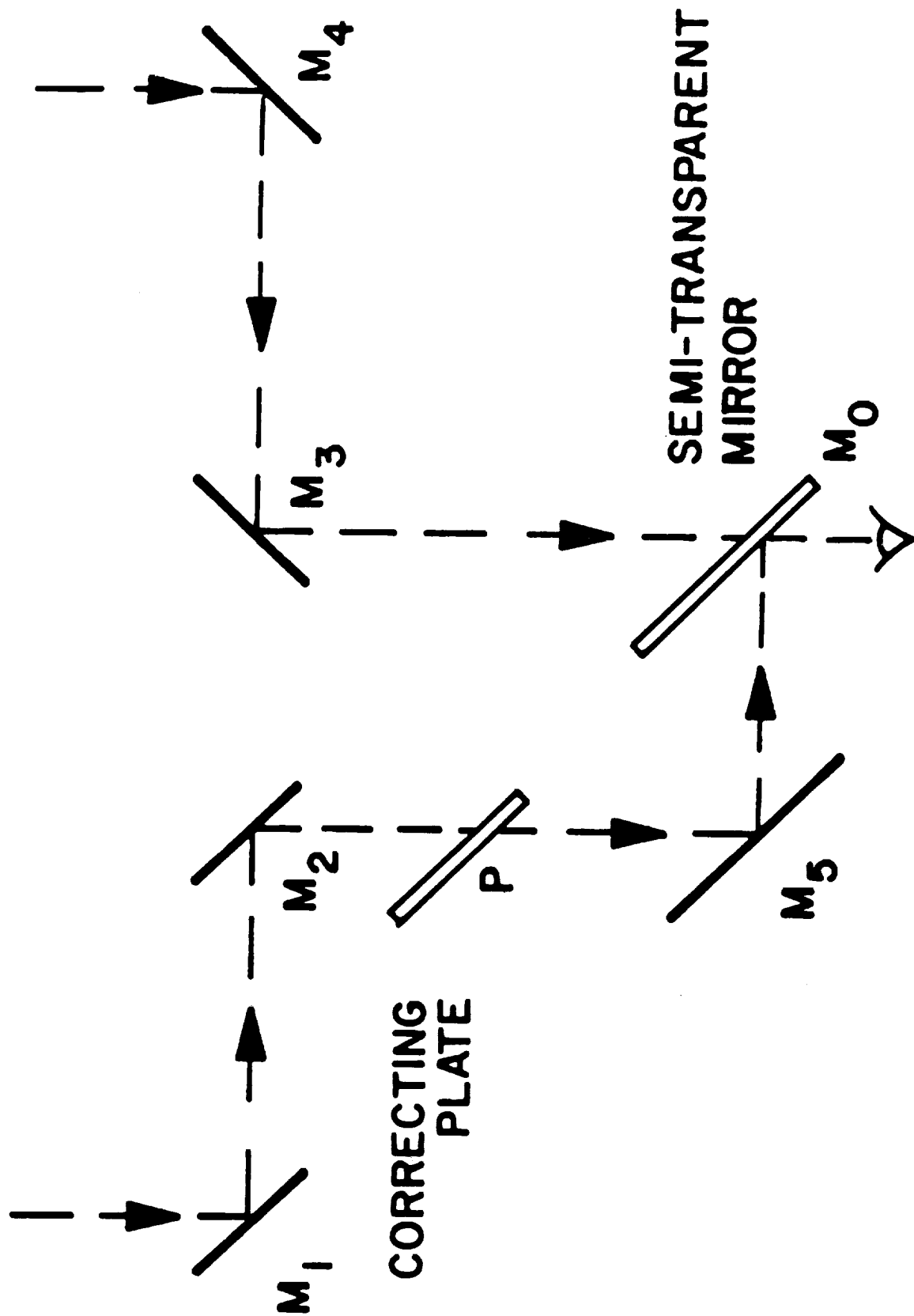

Figure 1: A schematic representation of a Michelson interferometer.

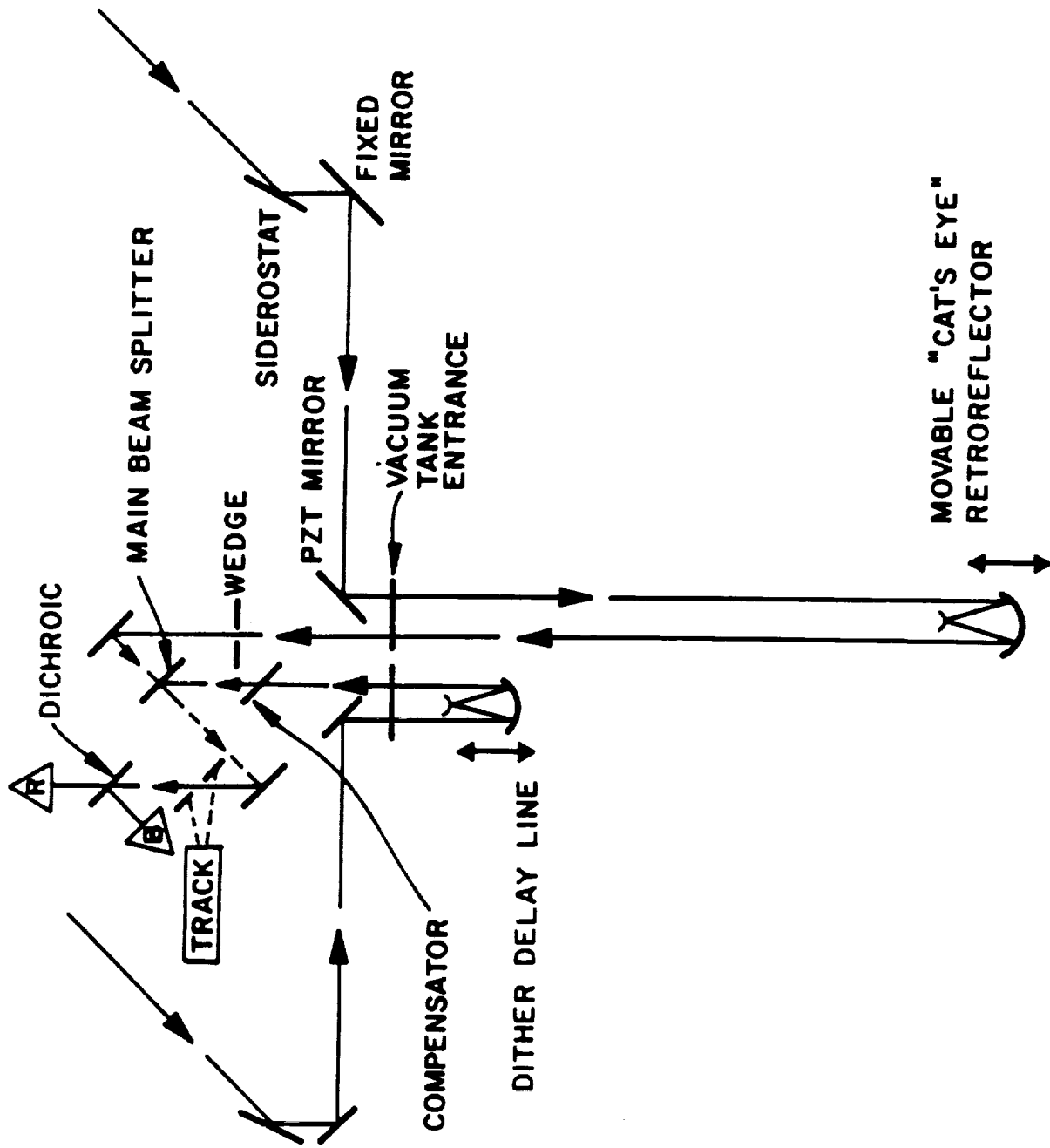

Figure 2: Diagram of a Michelson interferometer as embodied in the Mark I-III stellar interferometer. Note the dither delay line and the precise delay line to phase the interferometer.

ORIGINAL PAGE
BLACK AND WHITE PHOTOGRAPH



Figure 3: The Mark III of Mt. Wilson stellar interferometer. Note the 100-in. telescope dome in the background.

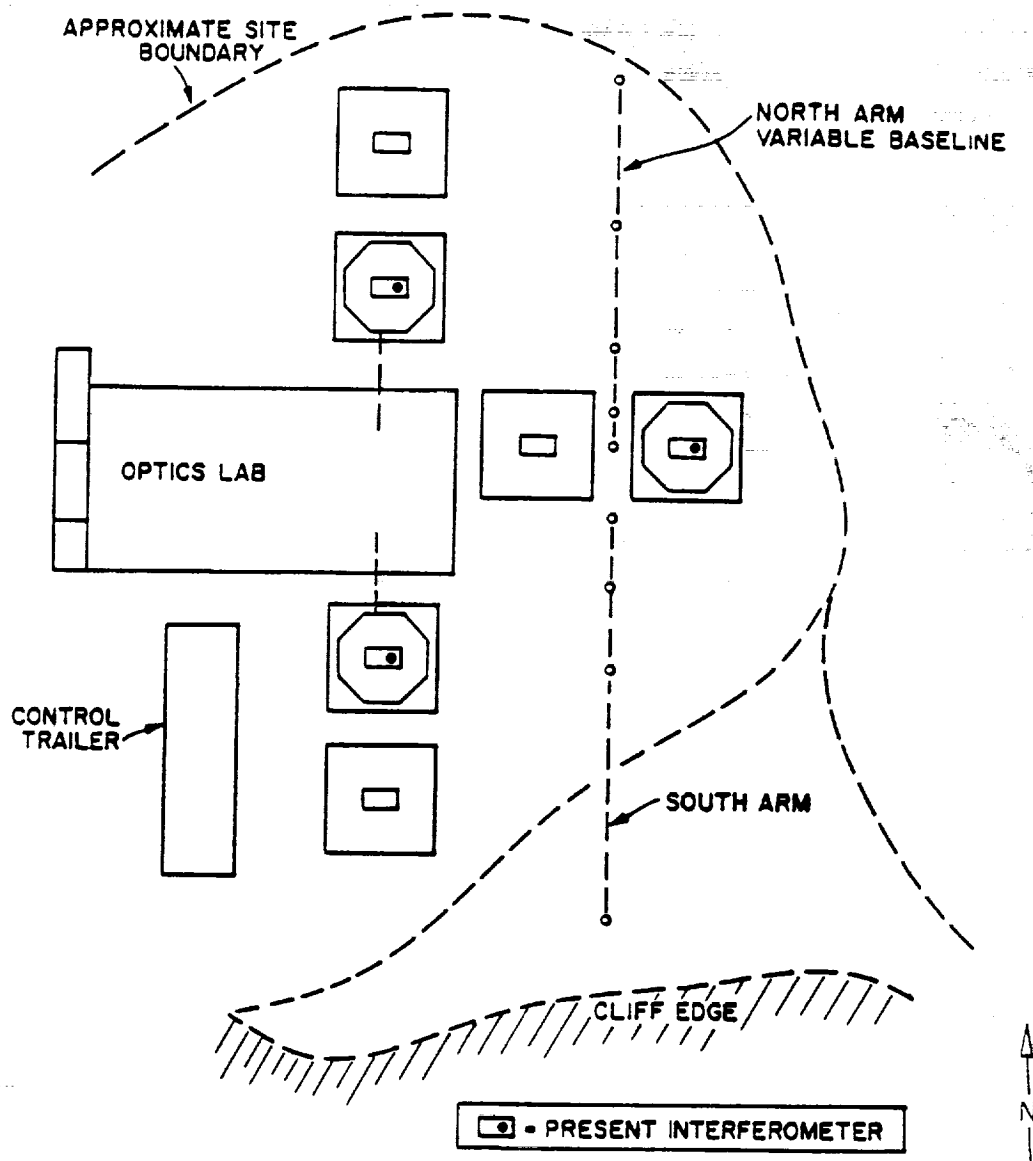

Figure 4: Diagram of the layout of the Mt. Wilson stellar interferometer. Note the 4-30 m North-South variable baseline.

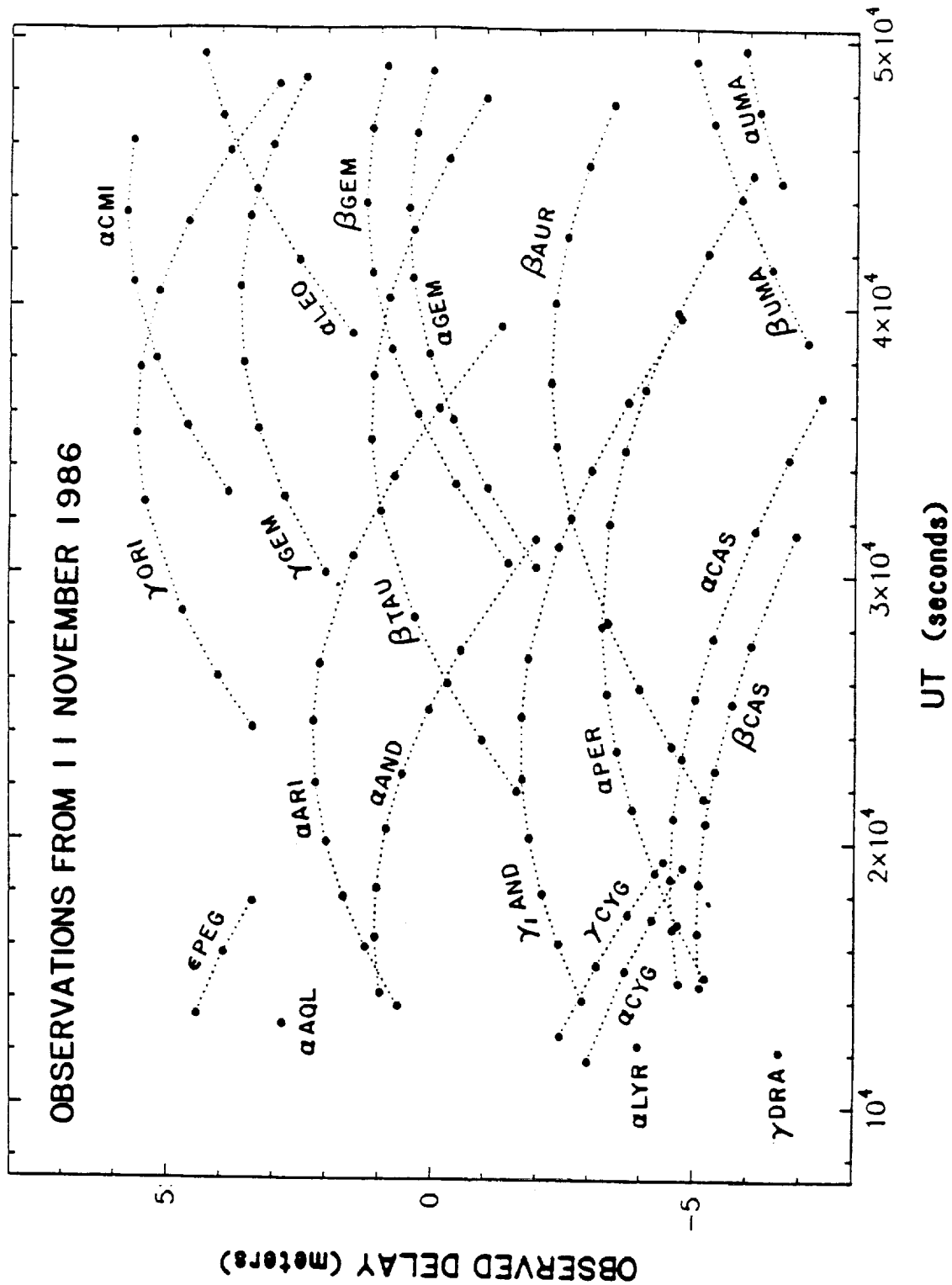

Figure 5: The observed delay as a function of time for November 11, 1986. Note that the arc contains the observation of a single star. On this night, more than 180 observations were made of 20 stars.

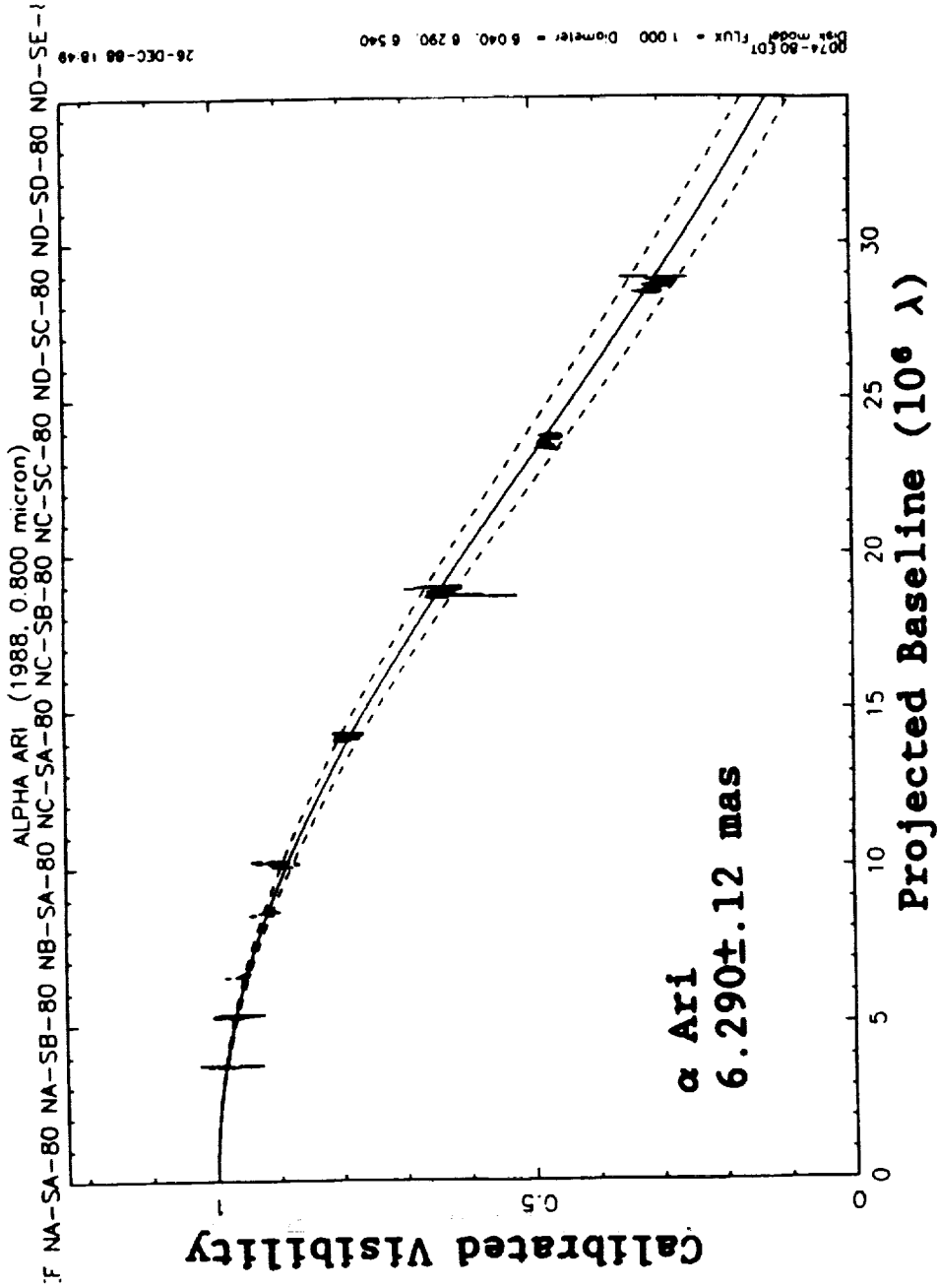

Figure 6: Visibility curve for the star alpha Arietes obtained with the 4-30 m variable baseline. The solid curve is the least squares fitted visibility curve to the data which has a diameter of 6.29 mas. The dotted lines are the expected visibility curves for a cylinder 0.25 mas higher and lower than the least squares value.

THE OPTICAL VERY LARGE ARRAY AND ITS MOON-BASED VERSION

Antoine Labeyrie

CERGA/OCA

06460 Saint Vallier, France

Abstract

An Optical Very Large Array (OVLA) is currently in early prototyping stages for ground-based sites, such as Mauna Kea and perhaps the VLT site in Chile. Its concept is also suited for a moon-based interferometer. With a ring of bi-dimensionally mobile telescopes, there is maximal flexibility in the aperture pattern, and no need for delay lines. A circular configuration of many free-flying telescopes, TRIO, is also considered for space interferometers. Finally, the principle of gaseous mirrors may become applicable for moon-based optical arrays.

Fifteen years after the first coherent linkage of two optical telescopes, the design of an ambitious imaging array, the OVLA, is now well advanced. Two 1.5 m telescopes have been built and now provide astronomical results. Elements of the OVLA are under construction. Although primarily conceived for ground-based sites, the OVLA structure appears to meet the essential requirements for operation on the Moon.

Results of the CERGA Interferometers

The small and large interferometers at CERGA have been extensively described (Koechlin 1988, Labeyrie 1988, Bosc 1988, Mourard 1988). After 12 years of prototyping and construction, the large "GI2T" interferometer has begun its observing program. With its full 1.5 m apertures, the GI2T obtained 500,000 exposures, most on the Be star gamma Cassiopea, but some also on Algol. The initial problem of vibrations in the mounts was solved by replacing the hydraulic elements in the drive system with small (20 W) electric motors.

Current developments include:

1. A laser metrology system, following the design of C. Townes for his heterodyne interferometer. It will stabilize the GI2T and serve as a prototype for the OVLA

array (figure 1). As described by Labeyrie et al. 1988, three laser beams are emitted by the central station toward a cat's eye reflector located at the center of each telescope. This gives three-dimensional information on telescope positions.

The initial use will be in the incremental mode to stabilize the baseline geometry during observation with fixed telescopes. Subsequently, fringe counting with several laser wavelengths is foreseen for absolute determination of the system geometry with moving telescopes, in the presence of seeing.

Pointing the laser beams toward the telescopes will have to be automated when the telescopes are moving and observing at the same time.

2. The study of a field-slicer system serving to observe a reference star and the main object at the same time (Bosc, Labeyrie, and Mourard 1988).
3. Based on compact OVLA technology, beginning the construction of a No. 3 telescope. For compactness, a fiberglass/epoxy sphere has been delivered to Haute Provence observatory, where the drive system is to be designed and built by A. Richaud and M. Cazalé. The sphere's diameter is 2.8 m, its thickness 6 mm and its mass 250 kg. It will contain a 1.5 m mirror apertured at $f/1.75$. Polished aluminum or replicas on new substrates currently studied are both considered for the mirror.

Steps Toward The Optical Very Large Array

The telescope No. 3 just mentioned serves as a prototype for the 27 telescopes of the OVLA (Labeyrie et al, 1988, Mourard, 1988, Bosc 1988). An XY carriage system is also needed to move the telescopes on the base platform. The platform concept makes delay lines unnecessary. It also allows varied options of aperture configurations, as required for observing different kinds of objects.

An XY carriage concept is being studied by D. Plathner at IRAM, and a prototype may be funded by INSU (France). This prototype will perhaps be used to move the OVLA prototype telescope when it is added to the CERGA system for exploiting a three-telescope array.

A somewhat different translation concept, shown in figure 4, involves 6 robotic legs. It appears suitable for smooth locomotion on either bare unprepared soil (including lunar soil) or an array of accurately positioned posts. The 6-legs solution has much similarity with insects: during motion each triplet of "feet" maintains a fixed triangular geometry, the linkage being achieved by neural networks, as is the case in insect brains.

The three-dimensional laser metrology system is essential for real time control of the telescope motion with about 1 micron accuracy. Even better accuracy may be needed for a moon-based OVLA, to benefit from the absence of atmosphere and achieve phased recombination of the beams within the Rayleigh tolerance. This may require ultraviolet laser wavelengths.

Alternately, reference stars can contribute to the fine level of geometry stabilization in space. A "field-slicer" optical system can allow the transmission of stellar and reference beams together in the coudé train (Bosc, Labeyrie, and Mourard, 1989). Fiber optics may also be considered, but "wireless" operations are of interest for moving telescopes.

Following the development of telescopes, carriages, and metrology components, OVLA development should proceed on a suitable site, possibly a plateau below the Mauna Kea summit. A few telescopes will be initially installed and more will be added to reach 27, or more if needed. A scaled-up version may also be implemented at some stage, with larger subapertures. A system combining, for example, 27 telescopes of 3.08 m, equivalent in aperture to ESO's Very Large Telescope (VLT), can potentially produce much more science than the VLT and other systems using a few fixed telescopes. The technical risks are also reduced, and probably the cost as well.

The Trio Concept of Space Interferometer

As described at conferences in Cargese (Labeyrie et al. 1984) and Granada (Labeyrie 1987), free-flying interferometer elements in high orbit can be stabilized, relative to each other and inertial space, by small solar sails. Interferometric baselines of 100 m can apparently be achieved in this way at geostationary altitudes, and they can reach several kilometers at 300,000 km from the Earth, at a site such as the L5 Lagrange point of the Earth-Moon system. It is yet difficult to judge the amount of technical developments required. Studies are currently being pursued by ESA. Prototype free-flyers may be launched together with commercial communications satellites

for qualifying small "sailing telescopes at geostationary altitudes. In spite of the lack of experience with solar sails and laser metrology in space, workable technical solutions may emerge at affordable costs.

The software aspects are seen as the major development effort required. A neural network approach appears of interest for reliability and optimal control.

A Lunar Version of the Optical Very Large Array

Adapting OVLA to a lunar site appears possible, at least conceptually (figure 1). Telescopes can be arranged along a ring. To avoid delay lines and achieve flexible aperture geometries, the ring has to be a deformable ellipse. Telescopes capable of walking on the bare soil or on an array of posts can meet this condition. Residual positioning errors can be compensated by small movable mirrors in the central optical system.

If very long baselines are desired, the central station could be located on a natural hill to avoid problems with the curvature of the Moon.

A shaded site is desirable for simplifying the baffling of the coudé beams, but also for thermal stability and low temperatures. Some energy must, however, be fed into the telescopes, preferably without wires. If the site is dark, a few watts of near infrared energy can be beamed toward photovoltaic panels on each telescope from a solar power station located on some illuminated ridge overlooking the array. This assumes a polar site.

The OVLA structure is suitable for progressively increasing the baseline spans; walking telescopes can initially remain within 1 km from the central station and later progressively venture farther away, as operating experience is gained.

In the central station, the beam recombining system must be interchangeable to accommodate changing requirements, different object types, and improving detectors. Thus, different kinds of pair-wise, triplet-wise or many-beam recombinators will be usable in the same way as focal instruments are interchanged on conventional large telescopes.

A metrology system similar to that currently developed at CERGA for the OVLA also appears desirable unless better configurations are found. In addition, it may be of interest to have

an optional field slicer, which allows the simultaneous observation of the object and a reference star located up to a few arc-minutes away from it.

Detection of Circumstellar Planets

Detecting bodies a billion time fainter, within an arc-second from a bright star, is probably feasible with a lunar optical interferometer. A procedure was proposed for the Hubble Space Telescope (Bonneau, Josse, and Labeyrie 1975) and photon-noise estimates did show that a few hours of observing time should suffice. Dust contamination on the large mirror of the Hubble Space Telescope, and its guiding jitter, are now considered to make things more difficult.

Individual telescopes belonging to a lunar array would themselves be in a better position than the low-orbiting space telescope for detecting planets. This would be achieved with long exposures in the photon-counting mode, coronal masks, and digital image subtractions while the telescope is rotated about its optical axis. The planet would appear at various position angles on the camera while the speckled pattern of stray light would remain fixed, and would thus disappear in the image subtraction process. Repeated rotations allow lock-in detection.

Unlike equatorial or alt-azimuthal mounts, spherical telescope mounts such as adopted for the OVLA do allow rotations around the optical axis (but not in the coudé mode). Conceivably, a specialized telescope could serve as a planet finder; and the array should be able to provide images of the detected planets. The images should show some resolved detail of planetary features in favorable cases.

Extracting a planet from the synthetic-aperture image obviously requires an excellent signal-to-noise ratio in the CLEAN algorithm. Calculations of photon noise are desirable to estimate the chances of success.

Gaseous Mirrors On The Moon

The above description of a lunar OVLA assumes conventional optical elements. The prospect of utilization gaseous mirrors may also be worth considering.

Since the concept of holographic telescopes with gaseous or pellicle mirrors was proposed (Labeyrie 1979), considerable progress has been made in the art of trapping atoms in laser

radiation fields. Recent results by Balykin et al. (1988) confirm that sodium atoms can be channeled in a standing spherical light wave.

Also, the cooling of atoms has been achieved at temperatures below 0.01K. This implies low residual velocities for the atoms, suggesting that the laser field could be turned off intermittently so as to minimize its contribution to focal plane straylight. At such low temperatures, if the density of atoms is high, the gas can condensate into a crystalline film. The narrow spectroscopic lines are affected in the process so that continuous trapping in the standing wave may also require some changes of the laser spectrum.

It is unclear yet whether such condensation into a crystalline film is advisable, and whether molecules such as organic dyes or even larger aggregates should be preferred to separate atoms. Theoretical investigations would be of interest. Using a vacuum tank, some laboratory testing of these techniques could also be initiated in the coming years (see figure 2).

It may thus become possible to install gaseous mirrors on the Moon, but it is difficult to guess what their size will be. Meters, hectometers, or kilometers? Depending on the sizes achieved, the large lunar instrument could consist of many small gaseous mirrors or a single large one.

Conclusion

A Moon-based interferometer is likely to achieve a major breakthrough in the optical penetration of the Universe. Advantages and drawbacks of free-flying versus lunar systems will have to be compared when more detailed design information is available for both kinds.

References

1. Balykin, V.I.; Letckhov, V.S.; Ovchinnikov, Yu.B.; Sidorov, A.I.; Shul'ga, S.V. 1988. Optics Letters, 13:11.
2. Bonneau, D.; Josse, M.; Labeyrie, A. 1975. Nieuwenhuijzen, J. ed. in Image Processing Techniques in Astronomy, Reidel (Holland).

3. Bosc, I. 1988. NOAO-ESO conf. proc.
4. Bosc, I.; Labeyrie, A.; Mourard, D. 1989. Proc. Japanese National Large Telescope, Tokyo, Nov. 1988.
5. Labeyrie, A. 1979. Astron. Astrophys. 77: L1-L2.
6. Labeyrie, A. et al. 1984. Kilometric Optical Arrays in Space, Proc. ESA Conf., Cargèse.
7. Labeyrie, A. 1987. Proc. ESA Workshop on Optical Interferometry in Space (supplements).
8. Labeyrie, A.; Lemaître, G.; Thom, C.; Vakili, F. 1988. NOAO-ESO Conf. Proc. High Resolution Imaging by Interferometry, Garching.
9. Mourard, D. 1988. NOAO-ESO Conf. Proc.

Panel Discussion

If a lunar base is to be established, it is certainly worthwhile for the terrestrial civilization to build an optical array at the same site. This is bound to be a prolific discovery machine that will clarify our picture of the stars, and probably their planets in the solar neighborhood; the many mysterious objects located elsewhere in our galaxy; the organization of neighboring galaxies; and the intimate behavior of strange bodies located at the largest observed distances. A lunar interferometer is likely to dwarf all the achievements of optical astronomy since its beginnings.

The comparative advantages and drawbacks of optical arrays in high orbit or on the moon will have to be clarified, as design efforts are pursued. The apparent cost advantage of free-flying systems loses its appeal if a multipurpose lunar base is to be installed. Although solar sails provide a simple way of translating array elements in space, it may turn out that walking telescopes can also be effective on the Moon and allow very long baselines of the order of 10 k. A basic advantage of the Moon is that the detecting camera can be buried fairly deeply in the lunar soil to protect it from cosmic rays and the spurious dark count caused by them.

Dr. Pilcher, from NASA's Office of Exploration, told us that NASA foresees international cooperation to implement lunar interferometry. A dedicated international institute with advanced engineering capabilities could be the most efficient way of tracking a project of such importance, that is, under contract with the national space agencies.

The ground-based OVLA project has been pushed and partially funded by the Association of Laboratories for Optical High-resolution Astronomy (ALOHA), which may soon change its name to WALOHA (W for worldwide) to stress its international scope. The history of previous collaborative projects such as the NASA/ESA collaboration on the Hubble Space Telescope, the European Southern Observatories, and CERN suggests that lunar interferometry could be handled more efficiently by an international astronomical organization than by the agencies directly. In Europe, an Institute for Astronomical Optical Interferometry is currently proposed for building the OVLA and VLT's auxiliary interferometer. Two international conferences were previously organized on space interferometry, at Cargèse in 1984 and at Granada in 1987. The next one should probably include sessions on the lunar concepts discussed at this meeting.

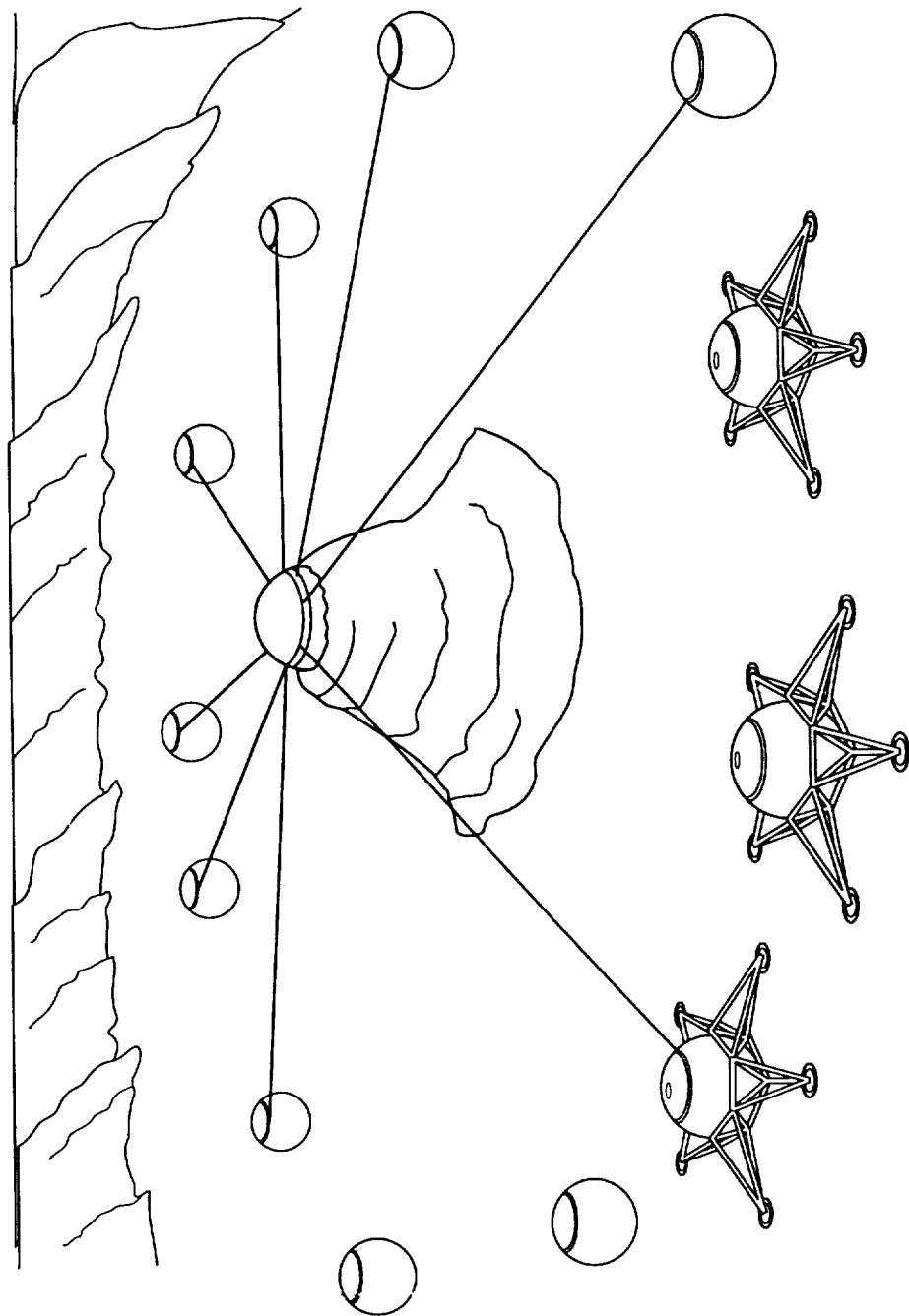

Figure 1: Lunar version of the Optical Very Large Array, which is studied for ground-based implementation in the coming years. The telescopes move in two dimensions during the observation to maintain the equality of optical paths without the need for delay lines. Shown here are telescopes equipped with six robotic legs, like insects, and similarly able to move smoothly under control of a laser metrology system.

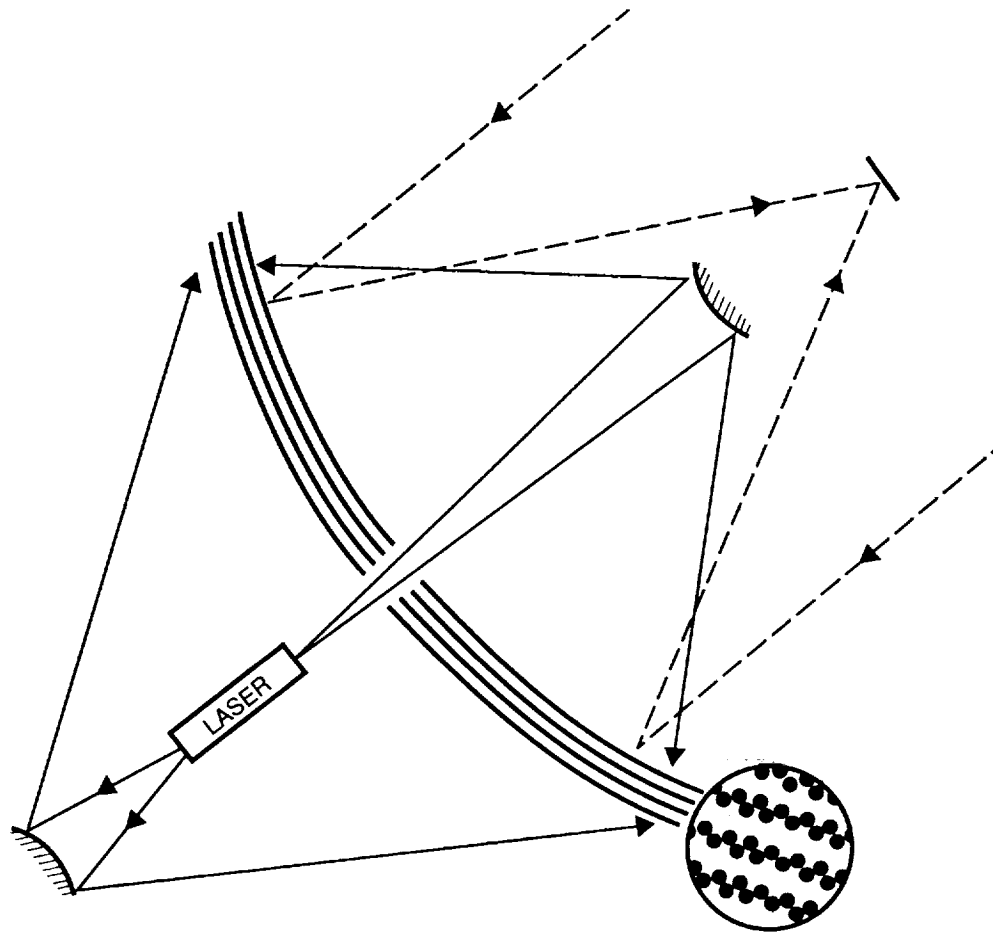

Figure 2: Principle of gaseous mirrors: a standing wave of laser light, having a paraboloidal shape, can trap atoms or molecules and cool them to low temperatures. This can reflect light from a star on axis toward the focus of the parabola. If many nodal surfaces, spaced half-wavelengths apart, are used, the mirror tends to be wavelength-selective. For broadband reflectivity, it appears possible to use a single nodal surface selected by adjusting the corresponding path difference to zero. Atoms are pushed toward this particular nodal surface if a saw-tooth modulation is applied to the laser wavelength. When the wavelength is shortened, the standing wave pattern shrinks toward the zero-order node, and pumps the atoms toward it.

Once the atoms are positioned and cooled, the laser can be turned off intermittently to avoid contaminating the faint stellar beam.

HIGH RESOLUTION IMAGING AT PALOMAR

Shrinivas R. Kulkarni*

Palomar Observatory, 105-24
California Institute of Technology
Pasadena, CA 91125

Abstract

For the last two years we have embarked on a program of understanding the ultimate limits of ground-based optical imaging. We have designed and fabricated a camera specifically for high-resolution imaging. This camera has now been pressed into service at the prime focus of the Hale 5-m telescope. We have concentrated on two techniques: the Non-Redundant Masking (NRM) and Weigelt's Fully Filled Aperture (FFA) method. The former is the optical analog of radio interferometry and the latter is a higher order extension of the Labeyrie autocorrelation method. As in radio Very Long Baseline Interferometry (VLBI), both these techniques essentially measure the closure phase and, hence, true image construction is possible. We have successfully imaged binary stars and asteroids with angular resolution approaching the diffraction limit of the telescope and image quality approaching that of a typical radio VLBI map. In addition, we have carried out analytical and simulation studies to determine the ultimate limits of ground-based optical imaging, the limits of space-based interferometric imaging, and investigated the details of imaging tradeoffs of beam combination in optical interferometers.

Introduction

High-resolution imaging at optical wavelengths is clearly a technique of immense importance for astrophysics. Turbulence in the atmosphere degrades the angular resolution of ground based telescopes, e.g., the angular resolution of the Hale 5 m telescope at 6000 \AA is about 33 mas whereas, in practice, the angular resolution is no better than 1 arcsec. This discrepancy between theory and practice has been frustrating for astronomers especially since many questions in astrophysics can only be answered with high angular resolution imaging.

*Alfred P. Sloan Fellow and NSF Presidential Young Investigator Fellow

At optical wavelengths, Labeyrie showed that the corruption of the wavefront by the atmosphere can be overcome with his speckle autocorrelation technique. However, the autocorrelation technique cannot produce true images. At radio wavelengths, atmospheric corruption is also severe, especially in VLBI. Despite this, radio astronomers have been able to obtain true images from VLBI data by using "closure phases" - a technique invented by Jennison and vigorously exploited for VLBI applications by the Caltech VLBI group. Closure phase imaging and the closely related technique of self-calibration (see Pearson and Readhead 1984 for a review) now form the basis of all radio imaging.

Given our close association with radio astronomical imaging, we started a group at Caltech two years ago with a view of applying the eminently successful radio imaging techniques to optical wavelengths. The following people constitute the group: A. Ghez, P. Gorham, S. Kulkarni, T. Nakajima, G. Neugebauer, J.B. Oke, T. Prince and A. Readhead. We have concentrated on two different techniques: the Non-Redundant Masking (NRM) and the Fully Filled Aperture (FFA) technique. Each has its own strengths and weaknesses.

The NRM technique is the exact analogue of a linked radio interferometer like the Very Large Array (VLA). The interfering fringes formed by light from a number (5 to 8) of small sections of the Hale 5-m telescope are recorded by a photon-counting detector. Just as in VLBI, closure phases are evaluated every coherence time interval and images are made using VLBI software developed at Caltech.

The FFA technique makes full use of the collecting area of the telescope. This is a higher-order extension of Labeyrie's speckle interferometry technique with the principle advantage that the closure phases can be measured. Thus, true imaging is possible with the FFA. The method was invented by Weigelt and coworkers (e.g., Lohmann, Weigelt, and Wirnitzer 1983) and is now being experimented by almost all active speckle interferometry groups. In this method, the turbulence caused by the atmosphere defines the baselines in some unknown fashion. We compensate for our ignorance of the perturbing atmospheric phase field by calculating the closure phases of *all* possible triplets of baselines. Thus, FFA reduction necessarily involves supercomputers.

The primary goal of our group has been to understand the sensitivity and the limitations of these techniques with a constant view of getting some astrophysical payoffs in the process. To this end, we have designed and built a camera specifically for optical interferometry and used it in two

successful runs on the Hale 5-m telescope. We have now reconstructed high quality images of binary stars and asteroids at angular resolution approaching the diffraction limit of the Hale 5m telescope. We have carried out analytical and numerical simulations to understand the absolute limiting sensitivity of ground based high resolution imaging and to determine optimal methods of combining beams in optical and IR interferometers. We are now at a stage where we can start defining and begin approaching the practical limitations of ground-based high resolution imaging.

The Prime Focus Camera

The Prime Focus Camera essentially consists of a pair of lenses and a microscope objective to expand the image scale (figure 1). The pair of lenses acts as a transfer lens and transfers the image from the focal place of the telescope to another plane. The f -ratio of the telescope at the prime focus is about 13 arcsecs/mm, whereas our detector has an active area of 25 mm. An x80 microscope objective enables us to magnify the stellar image to match the detector's size.

The detector is a position-sensing, resistive anode photomultiplier tube (ITT #FM 4146; see Lampton and Paresce 1974). It consists of a red-extended photocathode (MA-2) followed by a stack of five microchannel plates in a V-Z pattern and terminated by a special two-dimensional resistive anode. Ratios of the charges collected at these four corners are processed by an analog processor built by Surface Science Laboratories to yield the x and y coordinate of the photon. For each primary photoelectron the analog processor generates 20 bits of spatial information and 1 strobe pulse. These are passed to a camera controller designed and built by the Palomar electronics group. The controller appends 12 bits of timing information and stores the resulting event in a FIFO buffer memory, the contents of which are DMAed into a μ Vax and thence recorded on a magnetic tape for further processing. At suitable intervals, a 32-bit absolute time marker is added to the data stream. The net result is that we are able to deduce the arrival time of the photons to 10 μ s, which is more than sufficient for speckle applications.

The overall efficiency of our current system at $\lambda 6500 \text{ \AA}$ is one percent and is primarily determined by the net detector efficiency of two percent with the rest being due to telescope and optics.

The apparatus as described above is used to collect FFA data. For NRM we introduce a mask approximately at the focal plane of the first lens (see figure 1). There is a one-to-one mapping between this plane and the primary telescope with a demagnification factor of about 200. Thus, a hole or aperture in the mask of size 0.5 mm corresponds to an aperture of 10 cm at the primary telescope. The effect of introducing the mask is equivalent to blocking out most of the primary mirror except for the 10-cm patches defined by the mask. Stellar light from these patches interferes, and the resulting fringes are recorded by the photon-counting detector.

Three conditions are necessary to obtain closure phases:

1. The aperture size must be smaller than the spatial coherence scale length of the atmosphere, i.e., less than r_0 , the Fried parameter.
2. The frame integration time must be less than τ_0 , the temporal coherence scale length of the atmosphere. τ_0 is proportional to r_0 and depending on the wind speed is any value between a few ms to a few tens of milliseconds.
3. The light from these apertures must arrive at the detector with the same path length, i.e., the rays need to be focused. Path length compensation needs to be accurate to $(\lambda/\Delta\lambda)\lambda$ where $\Delta\lambda$ is the bandwidth. Thus the telescope optics need not be perfect to fractional wavelength accuracy as long as narrow bandwidths are employed.

The $n_b = n(n-1)/2$ fringes caused by the interference of the n beams lie on top of each other in the detector plane. In the Fourier or spatial frequency domain the fringes are transformed to δ -functions, the amplitude and phase of which contain information about the structure of the source. The mask hole geometry is so chosen that none of the n_b spatial frequencies coincides i.e., the mask is nonredundant. To increase the spatial frequency coverage, the mask is rotated at a variety of position angles. With about a dozen rotations the entire 5-m aperture can be synthesized. The details of data reduction are discussed in the next section.

Image Construction Software

The NRM data reduction parallels the radio VLBI reduction. The data reduction is done on the Convex supercomputer in the astronomy department at Caltech. An optimal coherent

integration interval τ_0 is chosen by empirically evaluating the power spectrum for a range of τ_0 . Once τ_0 is chosen, the data are divided into "frames" by collecting photons that arrive within one coherent integration interval. Each frame is Fourier transformed and the resulting n_b spatial frequency phasors are used to obtain the $n_t = n(n-1)(n-2)/6$ "triple products" or the "bispectrum" phasors, the phase of which is the closure phase. After many frames have been processed, the resulting bispectrum vectors are fed to the radio VLBI software. Additional details can be found in Nakajima et al. (1989).

The FFA data reduction is necessarily complicated and requires a true supercomputer. We have used Caltech's NCUBE supercomputer, a 512-node concurrent computer. Each node has the computing speed of a Vax 11/780 and a local memory of 512 kbytes. The reduction consists of several steps:

1. Recover amplitudes from the average autocorrelation functions (ACF) of object and calibrator frames.
2. Compute average object and calibrator bispectrum and thence calibrated closure phases.
3. Recover object Fourier phase from the calibrated object phases through a least-squares minimization procedure.
4. Produce a dirty map through direct Fourier inversion.
5. Deconvolve the true image from the dirty image using standard radio astronomy deconvolution techniques like CLEAN.

In practice, there are many biases, some of which arise from the detector, others from the telescope and, finally, some from the discrete nature of photons. These biases have to be understood before any reliable imaging can be done. Our group has made tremendous efforts to understand these biases and only after a lot of hard work are we in the situation where we have a reasonable idea of these biases. We consider our FFA program as one of our major achievements of this year. The details of our algorithm may be found in Gorham et al. (1989a, c).

At the current time, we calculate only the near-axis bispectrum points, about $\sim 10^4$ triple products. Despite this simplification, our present algorithm requires $\sim 5 \times 10^6$ floating point operations per frame. A typical data set ($\sim 2 \times 10^4$ frames) can currently be reduced in ~ 4 CPU hours. Extending the algorithm to include the full bispectrum would increase this to 5 CPU days!

At the current time, we do not do any kind of "flat fielding" since the detector appears to have a uniform response and there are no glaring artifacts.

Results

We had two observing runs in 1988, one in April and the other in July. We observed a wide variety of objects with the FFA and the NRM methods. Data were obtained in the red region (6500 Å) with a bandwidth of 30 Å. In this section, we summarize the success of our group with the NRM and the FFA method. We end it with a summary of the theoretical work done by our group.

Non-Redundant Mask Method

From the April data, we have been able to successfully construct images of two binaries using the NRM technique. The results are now in press (Nakajima et al. 1989).

β Corona Borealis. This is a spectroscopic binary with visual magnitude ~ 3.7 mag. Our synthesized image (figure 2) reveals a binary system with $\Delta m = 1.6$ mag, position angle $= 75^\circ$ and a separation of 231 mas. A restoring beam of 50 mas FWHM was used. The largest spurious component is -2 percent of the maximum. Thus the dynamic range defined as the ratio between the maximum and the largest spurious component is 50:1, which is consistent with the SNR of the observed closure phases.

Hercules. This is a double-lined spectroscopic binary with a visual magnitude of 4.2 mag. Our synthesized image (figure 2) shows a binary system of separation of 71 mas, magnitude difference of 2.5, and position angle 31° . The dynamic range is about 30:1, worse than expected from the SNR of the closure phases. We suspect that the decrease in dynamic range from the theoretically expected value is due to systematic errors in the calibrated amplitudes.

Fully Filled Aperture Method

As mentioned in the previous section, the program to reduce the FFA method took a long time to develop. The results we have obtained certainly have paid off our big investment.

Binary Stars. We have imaged a wide variety of binary stars with separation ranging from three to ten times the diffraction limit of the Hale 5-m telescope. The dynamic range in the *dirty* images is about 25:1. Application of deconvolution procedures is expected to further increase the dynamic range. The dynamic range attained in the FFA method appears comparable to that of objects by the NRM method. This suggests that were it not for the count rate limitation, the dynamic range of our FFA images would be even higher. These results are now being written up for submission to the *Astronomical Journal* (Gorham et al. 1989a).

Asteroids. Perhaps this is the most exciting science that is coming out of our effort. For 2 Pallas we have achieved a resolution of ~ 100 mas. The dynamic range of the image is about 15:1. We see evidence of the terminator line (figure 3), consistent with the solar phase angle and inclination of the asteroid at the time of the observation. We observed a maximum projected diameter of 510 km and a minimum of 450 km, consistent with the recent estimates of higher ellipticity for Pallas than had been previously thought. The apparent shape of the asteroid supports the identification as a triaxial ellipsoid.

For 14 Irene, we have achieved a resolution of ~ 50 mas. We find a maximum diameter of 220 km and a minimum of 135 km, giving an axial ratio for this projection of 1.6. We find a significant asymmetry in the brightness of one half of the asteroid image compared to the other with an apparent magnitude difference of ~ 0.7 . Irene is clearly nonspherical. This is not surprising since its size is below the critical size above which asteroids are expected to be approximately spherical. Both these exciting results will soon be submitted to the journal *Icarus* (Gorham et al. 1989b).

Unfortunately most of the FFA data we obtained last year appears to have suffered from detector saturation. In our detector, owing to the high gain, a single primary photoelectron results in cascade of about 10^7 secondary electrons. These electrons are depleted along the bores of the five microchannel plates and get replenished on a time scale of several tens of milliseconds. During this time, that pixel is effectively dead. We now find that the counting rate has to be kept below 10^4 Hz to avoid this problem. Thus, we believe that the dynamic range of images obtained from the

FFA method can be even significantly higher than reported here. We are proposing to build a new kind of detector (see last section) to overcome this problem.

Analytical and Simulation Studies

We have made great strides in our theoretical understanding of the sensitivity and limitations of optical and IR interferometry. The following listed theory papers have been either published or prepared for publication:

"Signal to Noise Ratio of the Bispectral Analysis of Speckle Interferometry" by Nakajima (1988). An exact expression for the SNR of the bispectrum phasor is derived including the effects due to photon noise. A computer simulation of the atmosphere phase corruption assuming a realistic model (the Kolmogorov spectrum) was used to gain an understanding of the FFA method. Our results showed that the earlier paper by Wirnitzer was in error and the limiting sensitivity of the FFA is probably about the 13-14th mag.

"Self Noise in Radio and IR interferometers" by Kulkarni (1989). Conventional radio imaging theory ignores the crosstalk between fringe phasors. The approximation is not valid for strong sources. In this paper, we derive an exact expression for the variance in a synthesized image. Our analysis indicates that some of the best VLBI and VLA images are not limited by calibration errors but by the self noise of the source itself. Finally, our analysis gives new insights into the closure phase concept. In particular, we argue that the concept of "unique" closure phases is not a very meaningful one and that especially at low SNR levels typical of IR interferometers all closure phases must be considered.

"Noise in Optical Synthesis Images I. Ideal Michelson Interferometer" by Prasad and Kulkarni (1989). We study the distribution of noise in images produced by an ideal optical interferometer, e.g., a space-based optical interferometer. We explicitly consider the crosstalk between the fringe phasors, and estimate the variance in the synthesized image at an arbitrary pixel. Two extreme cases of beam combination geometry are considered: the first, an ${}^n C_2$ interferometer for which each of the n primary beams is subdivided $(n-1)$ ways and pairs of sub-beams are combined on $n(n-1)/2$ detectors and, the second, an ${}^n C_n$ interferometer for which all the n beams interfere on one detector. We show that in both cases the signal-to-noise ratio (SNR) in the synthesized image is proportional to \sqrt{L} where L is the total number of photons intercepted by

the entire array. However, the distribution of the variance depends on the details of beam combination and whether the zero spatial frequency components are included or not. Thus, our principal conclusion is that beam combination geometry should *not* be a major design issue for any future space-based interferometer. However, given all things equal, we recommend an nC_2 interferometer for its uniform variance with a negligible loss in sensitivity.

"Noise in Optical Synthesis Images II. Non-Redundant Masking: Sensitivity and Limitations" by Kulkarni and Kakajima (1989). In this paper we derive the distribution of noise in synthesis images produced from the bispectrum data using the NRM method on large optical telescopes. We show that the variances and covariances depend on the fringe power on other baselines. This dependence poses additional restrictions on the design of non-redundant masks if the net variance has to be minimized. At high photon rates, crosstalk is severe and, as a result, the covariance terms collectively dominate over the variance terms. Despite this, the overall SNR performance in the synthesized image is nearly as good as an ideal Michelson interferometer. The covariance terms contribute significantly even at moderate photon rates. The implication of this result on image construction is discussed. At very low photon rates, the triple products become essentially uncorrelated, despite which the SNR in the synthesized image is considerably worse than that of an image synthesized from an ideal Michelson interferometer. In this regime, the beam combination geometry is important and optimal sensitivity is obtained when the number of beams converging onto the detector is 7 - a result which has important repercussions for beam combination in large interferometers like the proposed European Southern Observatory's Very Large Telescope. Finally, we discuss how the standard NRM method can be extended to include the entire collecting area of large telescopes. We find that the "extended" NRM method is superior to the FFA method at high light levels. At very low light levels, extended NRM (ENRM) gives nominally similar performance as FFA. However, we argue that in reality, FFA is more sensitive than ENRM for faint objects.

"Amplitude Recovery Using the CLEAN Algorithm: Applications to Astronomical Speckle Interferometry" by Gorham et al. (1989c). Labeyrie first showed that the power spectrum of an object corrupted by the atmosphere is the product of the atmospheric+telescope transfer function and the object power spectrum. Traditionally, the deconvolution of the object power spectrum from the measured spectrum is done in the spatial frequency domain or the Fourier domain. This method suffers from problems, especially with data obtained from photon counting detectors which cannot tolerate high photon rates. As a result, the atmospheric+telescope transfer function can be

measured to rather low precision. In such cases it is advantageous to carry out the deconvolution in the ACF domain. We have applied the CLEAN deconvolution algorithm to real data and obtained excellent results.

Plans for the Future

We are now at a stage where we can successfully image objects up to 5th magnitude by NRM method and objects up to 9th magnitude by FFA. These sensitivity limits arise from the following factors:

1. Low Detector Efficiency. The current detector efficiency is only 2 percent. Clearly there is much room for improvement here.
2. Narrow Bandwidth. Currently we employ bandwidths of only 30 Å.
3. Detector Saturation. The current detector saturates at rates of about 10^4 Hz, and this affects the FFA method the most. It prevents us from using strong calibrators which, in turn, limits the calibration procedure - crucial for any decent image construction.

In collaboration with Mike Shao at the Jet Propulsion Laboratory, we are proposing to build a PAPA detector (Papaliolios, Nisenson, and Ebstein 1985). This detector, especially when used with a GaAs front end, is expected to have a net detector efficiency of up to 15 percent and, furthermore, will enable us to operate at wavelengths as long as 0.9 μm . These two effects alone should result in an overall sensitivity gain of a factor of 20.

With help of a grant from the Keck foundation, we are now building a computer-controlled dispersion corrector. This corrector will allow us to employ bandwidths as large as 1000 Å -- resulting in another increase of sensitivity by a factor of three.

We are exploring techniques that combine the best of FFA (high sensitivity, high dynamic range) and NRM (high resolution and high dynamic range). Our preliminary computer simulations show that we can employ masks with aperture sizes many times larger than r_0 . Larger apertures will necessarily lead to overlap of the fringe phasors in the spatial frequency domain and loss of fringe visibility. Our simulations show that despite this, the increased photon

rate results in an overall increase in the sensitivity. Another such technique for which we have, in fact, obtained data is the annular mask technique. Both these techniques differ from FFA in that we control the mix between the high and low spatial frequency components. In particular, an annular mask offers the highest angular resolution without visibility degradation from the low spatial frequency components as in the standard FFA.

Finally, we are now turning our attention to the infrared. There is plenty of exciting science and lots of bright sources. An IR run has been scheduled for summer this year. So perhaps the next time we meet I hope I can show you some exciting IR high angular resolution pictures.

The bulk of the work performed by our group has been supported by a generous grant from the W.M. Keck Foundation. I thank Jack Burns for supporting my travel to this meeting.

References

1. Gorham, P.W.; Ghez, A.; Kulkarni, S.R.; Nakajima, T.; Neugebauer, G.; Oke, J.B.; Prince, T.A.; Readhead, A.C.S. 1989a (in prep).
2. Gorham, P.W.; Ghez, A.; Kulkarni, S.R.; Nakajima, T.; Neugebauer, G.; Oke, J.B.; Prince, T.A.; Readhead, A.C.S. 1989b (in prep).
3. Gorham, P.W.; Ghez, A.; Nakajima, T.; Kulkarni, S.R.; Neugebauer, G.; Oke, J.B., Prince, T.A.; Readhead, A.C.S. 1989c (in prep).
4. Lampton, M.; Paresce, F. 1974. *Rev. Sci, Instr.* 45:1098.
5. Lohmann, A.W.; Weigelt, G.; Wirtitzer, B. 1983. *Appl. Opt.* 22:4028.
6. Kulkarni, S.R.; 1989. *Astron. J.* (submitted).
7. Kulkarni, S.R.; Nakajima, T. 1989 (in prep.).
8. Nakajima, T.; Kulkarni, S.R.; Gorham, P.W.; Ghez, A.M.; Neugebauer, G.; Oke, J.B.; Prince, T.A.; Readhead, A.C.S. 1989. *Astron. J.* (in press).

9. Nakajima, T. 1988. *J. Opt. Soc. Am. A* 5:1477.
10. Papaliolios, C.; Nisenson, P.; Ebstein, S. 1985. *App. Opt.* 24:287.
11. Pearson, T. J.; Readhead, A.C.S. 1984. *Ann. Rev. Astr. Ap.* 22:97.
12. Prasad, S.; Kulkarni, S.R. 1989. *Astron. J.* (submitted).

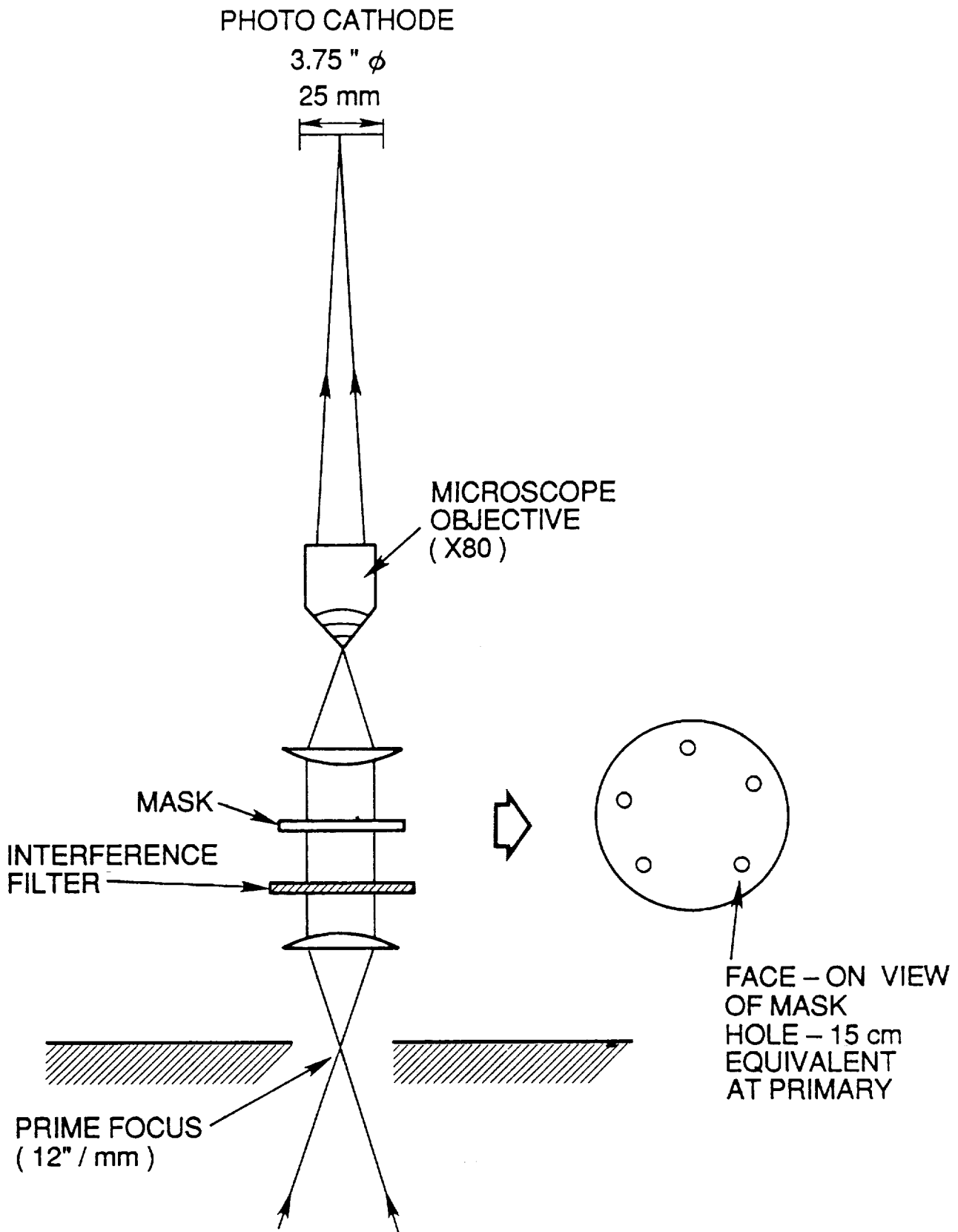

Figure 1: The speckle camera for use at the prime focus of the Hale 5-m telescope.

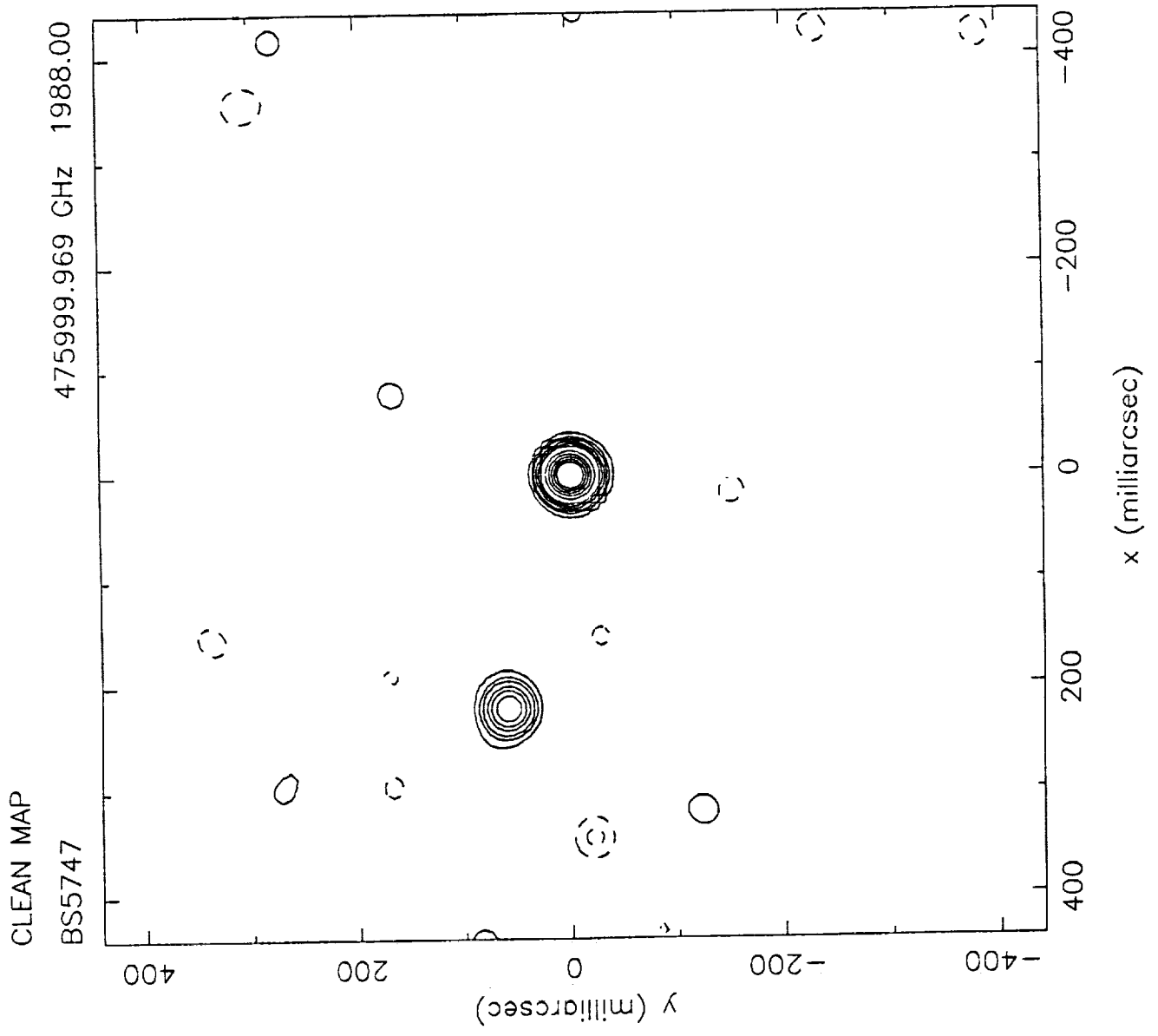

Figure 2a: Image of BS 5747 made using the NRM technique. Dynamic range is about 50:1.

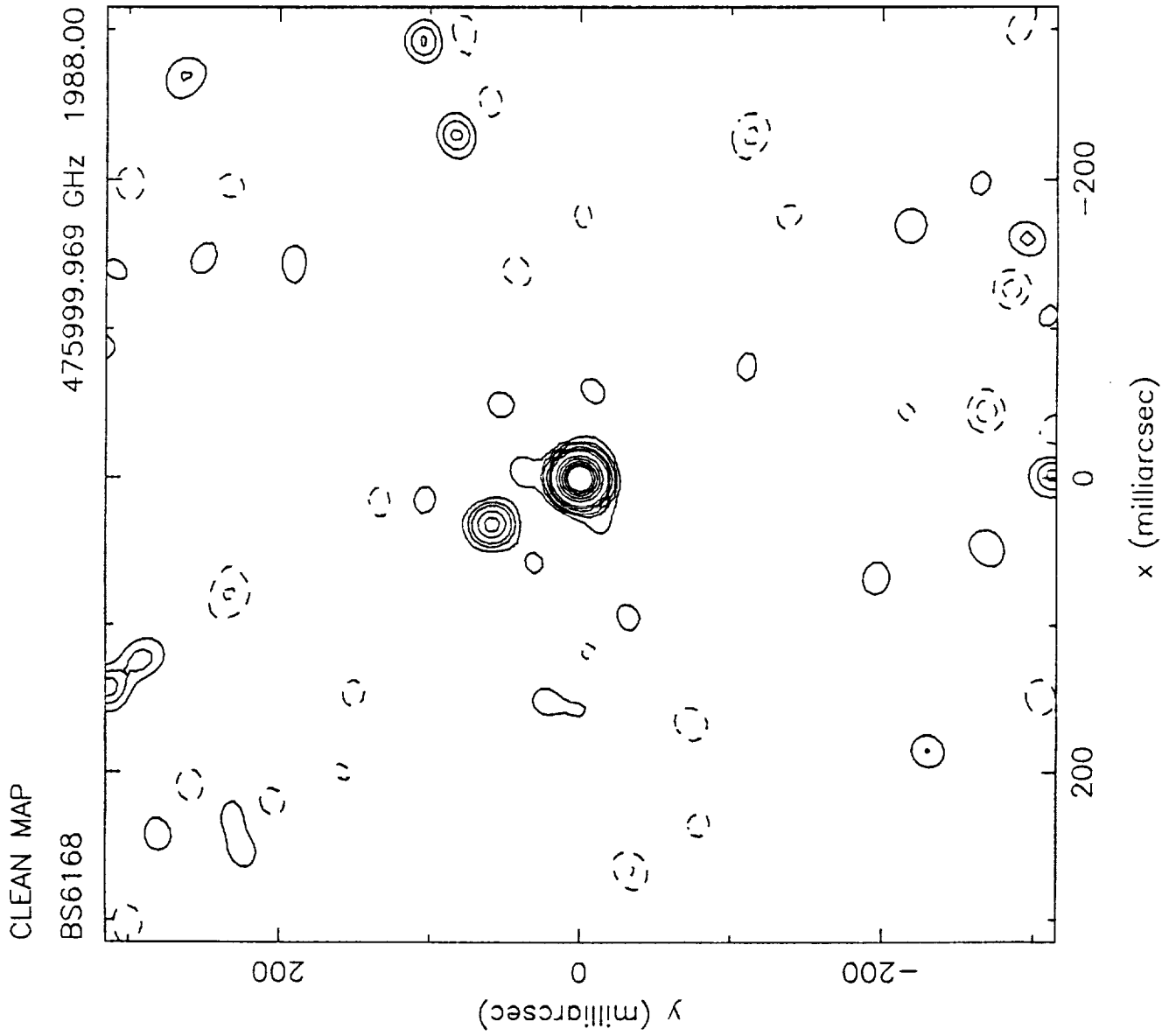

Figure 2b: Image of BS 5747 made using the NRM technique. Dynamic range is about 30:1.

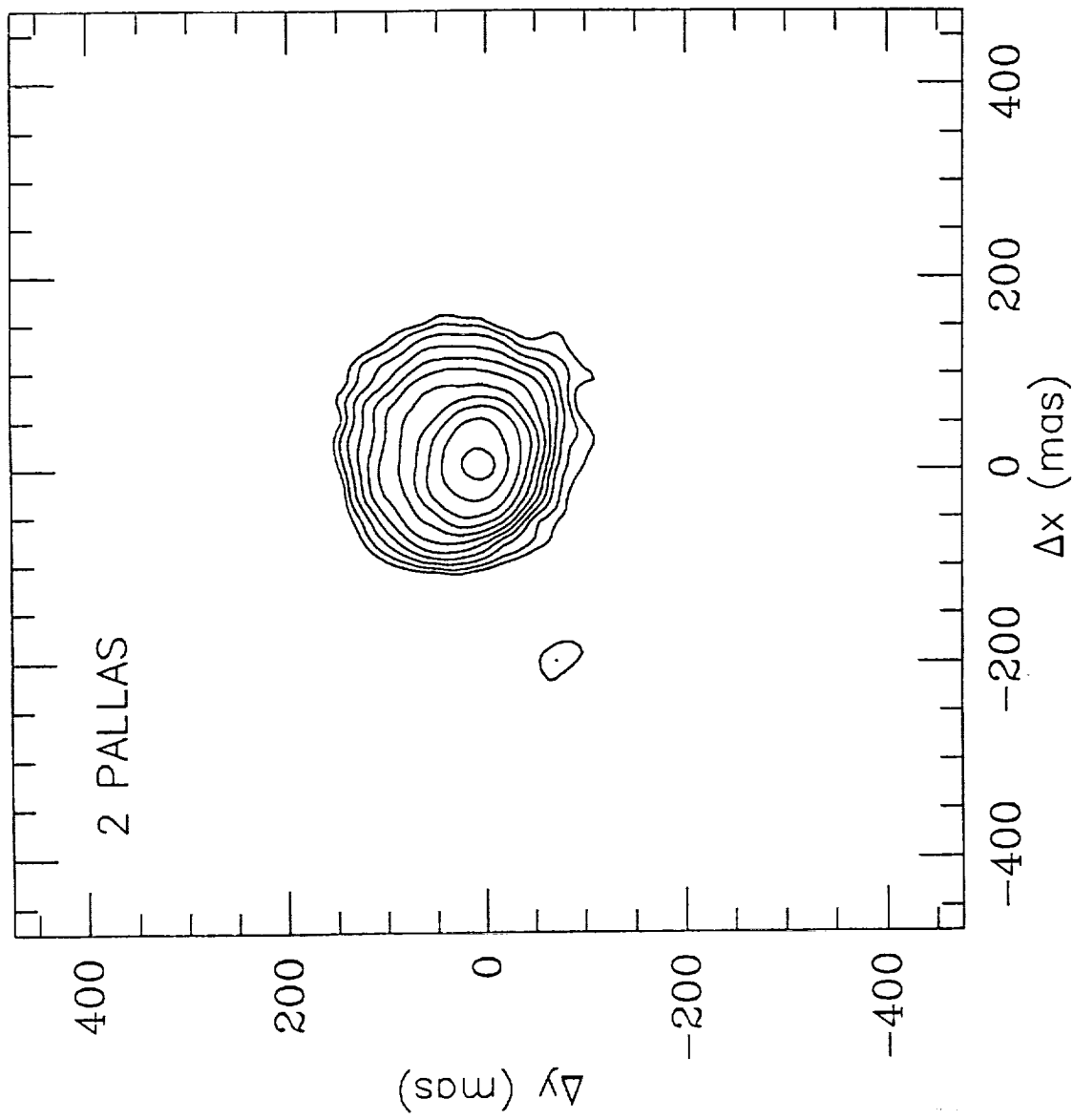

Figure 3: Image of the asteroid 2 Pallas made using the FFA technique. The lowest contour is 10% of the peak. North is up and East to the left. Note that the contours are steeper on the southeastern side as compared to the northwestern side. We explain this asymmetry due to illumination of the asteroid by the Sun.

RECENT ASTRONOMICAL RESULTS FROM
THE INFRARED SPATIAL INTERFEROMETER
AND THEIR IMPLICATIONS FOR LOUISA

W.C. Danchi, M. Bester, and C.H. Townes

Space Sciences Laboratory and Physics Department
University of California at Berkeley
Berkeley, CA 94720 USA

Abstract

A new heterodyne interferometer for the atmospheric window from 9-12 μm has been developed at the University of California at Berkeley during the past five years. This instrument, called the Infrared Spatial Interferometer (ISI), has been designed to use earth rotation aperture synthesis techniques developed in radio interferometry. It was moved to Mt. Wilson, California, in January 1988 and first fringes were obtained in June of that year. Systematic observations of some of the brighter late-type stars began shortly after the first fringes were obtained. We describe the basic principles and design of the ISI and give an overview of some of the initial results obtained from these observations. The implications of our work to the proposed Lunar Optical/UV/IR Synthesis Array (LOUISA) are discussed. We also analyze the conditions for the maximum signal-to-noise ratio of such an interferometer as a function of wavelength. The optimum wavelength is found to depend on the assumed scaling relation between telescope area and wavelength.

Introductions and ISI Design

During the 1970s our group developed and obtained astronomical results with a prototype heterodyne interferometer operating in the spectral window from 9-12 μm . This instrument had a fixed 5.5 m east-west baseline and demonstrated the fundamental principles of long-baseline interferometry in the mid-infrared (Johnson et. al. 1974). Based on the experience with this prototype instrument, we have designed and constructed a new interferometer using portable large-aperture telescopes of a novel design.

Figure 1 displays a schematic view of such a portable telescope, which we call a Pfund telescope. A 2.03 m diameter flat mirror supported on an altitude-azimuth mount is used to track an astronomical source. Light is reflected by the flat mirror onto a 1.65 m diameter parabolic mirror. This mirror focuses the light to a point behind the flat mirror. A dichroic mirror separates the infrared and optical signals. The optical light is used for guiding while the infrared radiation is mixed with radiation from a CO₂ laser, and is detected on an HgCdTe photodiode. The resulting intermediate frequency (IF) heterodyne signals from the two telescopes are processed using conventional radio techniques to find the interference fringes.

The choice of telescope geometry allows for a range of $\pm 55^\circ$ in azimuthal rotation angle from the position where the flat mirror points directly at the parabola, and for a range from -2° to $+55^\circ$ in altitude, with twice this angular range on the sky. Therefore the sky coverage is about half of the visible sky. Unlike conventional alt-az mounts, the Pfund mount has no singularity at the zenith. Another advantage of this geometry aside from compactness is that it has no support struts for a secondary mirror, which usually give rise to diffraction effects and partly block the aperture. One disadvantage is limited sky coverage, but this can be overcome by rotating the trailers by 180° .

The mounts for both mirrors are kinematically supported on reinforced concrete bases. The mirrors, detection optics, control system, and computer system are all contained within the custom-made semi-trailers. The current site has seven stations with east-west baselines ranging from 4 to 28 m and north-south baselines of up to 15 m, as well as baselines at intermediate angles. Normally the semi-trailers are mechanically decoupled from the mirror mounts, but to change baselines, a trailer is raised to carry the weight of the mirror mounts, driven to a new station, and then lowered to release the mirror mounts.

Pathlengths within each telescope itself are monitored by a HeNe laser metrology system indicated in figure 1 by the dot-dashed lines between the flat and parabolic mirrors. The position of the center of rotation of the flat mirror can be monitored with respect to bedrock by triangulation from a monument located near the trailer tires shown in the figure. The baseline length and orientation can then be monitored, assuming the bedrock is fixed and the monuments are thermally shielded and isolated from wind shaking. (cf. Townes 1984; Townes et al. 1986; Danchi et al. 1986).

Precise pointing is achieved using conventional incremental optical encoders with a resolution of about 0.24 arc sec in azimuth and 0.07 arc sec in altitude on the sky. This system has a blind pointing accuracy of less than 10 arc sec (rms) in azimuth and less than 2.5 arc sec (rms) in altitude on the sky. In the near future we expect to use laser metrology to directly measure the pathlengths between the two mirrors and, hence, the relative angle. This system has a theoretical precision of 0.008 arc sec on the sky, but atmospheric effects are expected to lower it to a practical precision of about 0.1 arc sec. (See also discussion by Danchi et al. 1986.)

The ISI uses a heterodyne detection technique much like that of the basic radio interferometer shown schematically in figure 2. In the heterodyne interferometer, a local oscillator signal and a signal from an astronomical source are mixed together. The result is the down-conversion of the sky signal into the IF band. A phase shifter can be used to adjust the relative phase (or frequency) between the two antennas which make up the interferometer. This allows one to compensate for the varying frequency of the interference signal due to the changing projected baseline resulting from the earth's rotation (lobe rotation). The chief advantage of the heterodyne technique is that the interference can occur at the IF band, which allows a greatly relaxed tolerance for the delay line, a device which compensates for the varying phase delay across the IF band resulting from the geometrical delay. In this way one obtains a "white light" fringe. At millimeter and centimeter wavelengths, the IF signals are quite often digitized so that both the delay and correlation can be achieved in digital correlators.

One major difference between a mid-infrared heterodyne interferometer and a typical centimeter or millimeter wavelength interferometer (which also uses heterodyne detection) is that the IF band for the IR interferometer must be much larger by comparison to obtain reasonable sensitivity. Thus our IF banks is as large as is reasonably practical (0.2-2.0 GHz). Instead of using a digital delay and correlation technique, we find that it is easier to use an analog delay line and a multiplying correlator. Other differences occur because of the short wavelength involved. One is that the local oscillator used in the mid-IR is a stable CO₂ laser rather than a solid-state source such as a Gunn diode. Another difference is that the local oscillator and signal beams are combined optically on a ZnSe beamsplitter and are then focused onto a cooled HgCdTe photodiode (Spears 1977). Rather than using a single local oscillator and a phase shifter, we use two CO₂ lasers, one in each telescope. One laser is free-running. A part of the output from this laser is sent from one optic's room through an air path between the telescopes to the optic's room of the second telescope, where it is mixed with the second laser beam. Then this laser is phase locked

to the first one to provide the correct phase and frequency difference between the two telescopes. The frequency difference between the lasers is chosen to compensate for the natural fringe frequency which varies due to the change in the projected baseline resulting from the rotation of the earth. We use a fixed fringe frequency of 10 Hz, which is sampled by an analog-to-digital converter at a rate of 100 Hz. Techniques used to ensure phase stability of the local oscillator signals between the two telescopes are somewhat similar to those used in radio interferometry (Thompson et al. 1986). A portion of the CO₂ laser beam, which is sent between the telescopes, is returned along the same path. The returned beam is mixed with a part of the original laser beam and the resulting interference fringes are used to measure the relative phase of the two beams. A constant round-trip phase is maintained by a simple servo loop controlling a variable pathlength device inserted in the optical path between the telescopes. More detailed discussions of the ISI detection system have been published elsewhere (Danchi et al. 1988).

Sensitivity is a major disadvantage of the heterodyne technique, particularly at shorter wavelengths (for continuum sources). Generally speaking, the heterodyne technique is favored for narrow bandwidths or when the background is large. Direct detection is preferred for large bandwidths and low backgrounds. (See for example Kingston 1978 and Burke 1985.) The ISI is estimated to obtain satisfactory signals from sources about six magnitudes weaker than the brightest 10 μ m infrared sources using realistic assumptions about bandwidths, quantum efficiencies, integration, and atmospheric coherence times (Danchi et al. 1988).

We turn now to some of the results from our initial series of observations with the ISI.

Recent Astronomical Results

The ISI reached two major milestones during the 1988 observing season. One was the detection of the first interference fringes on 29 June 1988. The other was the initiation of the observational program. Thus far one dozen of the brighter 10 μ m infrared sources have been observed. These sources were IRC+10216, VY CMa, α Ori, α Sco, σ Ceti, R Leo, VX Sgr, W Aql, χ Cyg, R Aqr, α Tau, and U Ori. The brightest source observed was the much studied carbon star IRC +10216 (CW Leo) with a flux of about 25,000 Jy; the weakest sources were α Tau and U Ori, each with a flux of about 700 Jy. (Here 1 Jy = 10⁻²⁶ W m⁻² Hz⁻¹.) During the 1988 observing season, we spent most of our time installing and debugging the telescopes, the pointing system, and the

detection system. The data which we will discuss here were obtained in a total of about one week of observing during a period of excellent seeing.

Figure 3 displays the power spectrum of the fringe signal on IRC +10216 obtained over a 512 second integration time. This figure was obtained by coadding 25 power spectra, each one obtained from a separate 20.48 second time section of the sampled data. Note that the spike occurs at the expected fringe frequency of 10 Hz. Note also the wings on the fringe extending to about 1 Hz on either side of the 10 Hz fringe signal. The wings on the fringe signal are due to fluctuations in the pathlengths from the star to the telescopes caused by turbulence in the atmosphere as well as perhaps by some wind shaking or mechanical vibrations in the telescope mounts. Turbulence associated with heat sources internal to the telescopes could also contribute to these pathlength fluctuations.

Another way to analyze the data is to calculate the amplitude and phase of the interference signal directly from the time series data. Here one essentially multiplies the fringe signal by $\sin \omega t$ and $\cos \omega t$, where $\omega = 2\pi \cdot 10$ Hz, and integrates over a time period corresponding to at least a few cycles of the 10 Hz waveform. The result of this computation on a portion of the data on IRC +10216 is shown in figure 4. Here we display the power in telescopes 1 and 2 as a function of time in seconds beginning at an arbitrary starting time, and the fringe phase and amplitude, using a 0.2 second integration time. The fringe phase is displayed in degrees and the fringe amplitude is shown in arbitrary units. The fringe phase clearly fluctuates from its mean value to an extremum and returns to approximately the main value again over a period of a few seconds. Such time scales are not surprising because the Mark III visible wavelength interferometer observed a Fried coherence diameter (r_0) of about 19 cm at $0.55 \mu\text{m}$ for an effective wind speed of 14 m sec^{-1} during a period of good seeing (Colavita et al. 1987). From these values one would expect the fringe phase to change by about one radian in about 0.5 sec. Thus a complete cycle of fluctuation should take a few seconds. Averages over periods of a few minutes will greatly decrease fluctuations and provide quite accurate phase measurements.

The power spectrum of fringe phase or pathlength fluctuations can be calculated from data similar to those in figure 4. A power spectrum has been calculated for some of the IRC +10216 data taken on 8 October 1988 and is displayed in figure 5. Two pieces of data were analyzed, each about 2.5 minutes in length. The data in figure 5 cover the frequency range from about 25 mHz and can be fit by a power law in frequency $P_L(\nu) \propto \nu^{-\alpha}$, where α can be fit to values between 1.3 and 1.5.

This power spectrum can be compared to that obtained with the Mark III interferometer (Colavita et al. 1987). Their data were fit by a low frequency asymptotic power law of the form $P_L(v) = C_1 B^2 v^{-2/3}$ for $v \ll v/B$, where B denotes the baseline length and v the wind speed. For frequencies such that $v \gg v/B$, their data were fit by a power law of the form $P_L(v) = C_2 v^{-8/3}$. Both asymptotic power law formulae can be derived from the Kolomogorov turbulence theory as has been discussed by Colavita et al. (1987).

To make a comparison with the Mark III data, one must scale the cross-over frequency (where the power law changes from the $-2/3$ to the $-8/3$ power) with the baseline length ratio. This scaling must be made because our data were taken with a 4 m baseline while the data of Colavita et al. were taken with a 12 m baseline. If we define f_1 to be the cross-over frequency for baseline B_1 and if f_2 is the cross-over frequency for baseline B_2 then $f_2 = (B_1/B_2)f_1$ because the cross-over frequency $f = (C_2/C_1)^{1/2} B^{-1}$. For pathlength fluctuations, power on the low frequency asymptote scales as the baseline ratio squared, i.e., $(B_2/B_1)^2$. When we scale the low-frequency asymptote and the cross-over frequency with the baseline from figure 7 of Colavita et al., we find that the agreement between the two data sets is excellent. Figure 5 displays the scaled asymptotes from figure 7 of Colavita et al. The low frequency asymptotes ($v^{-2/3}$) are indicated by the dot-dashed line in the figure and the high frequency asymptotes ($v^{-8/3}$) are drawn as the dotted line. Our data tend to lie slightly below their asymptotic power law, but this variation could easily be due to differences in the projected baseline between the two systems and source as well as the airmass. Note that their figures 6, 7, and 8 are all consistent with each other when one takes the variation in baseline length or airmass into account. For example, the data in figure 8 were taken with a baseline length of 3.1 m on the Mark II system while the data in figures 6 and 7 were taken with the 12-m baseline of the Mark III system. One would expect the low frequency asymptote of their figure 8 to lie $(12/3.1)^2$, or about 12 dB below that of figure 6 or 7, which is approximately what is observed. We must caution the reader that the analysis presented here is preliminary; more detailed analysis will be published elsewhere after further observations. The analysis presented here shows that coordinated observations of the same source observed simultaneously with both the visible and IR interferometers on Mt. Wilson could prove useful in identifying contributions from wavelength dependent fluctuations such as is expected from water vapor.

One further aspect of the current data set deserves a brief mention here. The visibilities of some of the observed sources can be computed from a comparison between the observed power in the interference fringes and the flux in a single telescope. Figure 6 displays an intercomparison

between the fluxes of three bright IR stars and the power in their interference fringes. Note that the single telescope flux for VY CMa lies about a factor of two above that for α Ori, whereas the power in the fringes for α Ori lies about a factor of five above the VY CMa. Thus, we must resolve VY CMa more than α Ori. Similarly the single telescope flux for IRC+10216 is about a factor of nine larger than that for α Ori, although the fringe powers vary by only about a factor of four. We can see that the ISI has the potential for accurate measurements of the fringe amplitudes and phases. Once these measurements are sufficiently accurate, one of the early scientific goals of the IR interferometer will be to determine the spatial distribution of dust around some of the brighter late-type stars. Such measurements should have important consequences for the study of the mass-loss phenomena of these stars.

Implications For The LOUISA Concept

In an interesting paper from the Conference on Lunar Bases and Space Activities of the 21st Century, Burke (1985) put forth a set of arguments in support of the construction of a Lunar Optical/UV/Infrared Synthesis Array (LOUISA). An obvious advantage of the Moon-based interferometer as compared to an Earth-based one is the lack of an atmosphere that causes fluctuations in the phase of the interference fringes and which is a primary limitation of interferometry on the Earth's surface. Clearly the low surface gravity would make it possible to build telescopes from lightweight structures. Also the stable soil would make an easy platform from which one might point and control the attitude of the individual telescopes as well as maintain the baseline orientation.

For the first interferometer built on the Moon, it is clearly appropriate to build a system for wavelengths shorter than the $10\ \mu\text{m}$ used for the ISI and to use direct detection rather than heterodyne techniques. However, some of the ISI experience, perhaps particularly with HeNe interferometer monitoring of distances for precision under varying conditions, should be of value in considering such a system.

An important question that has received relatively little attention with regard to the LOUISA concept is that of the optimum wavelength for the proposed interferometer array. One might envision that discussions could be based on a well-defined set of criteria, for example the signal-to-noise ratio, or on the ease of construction based on optical fabrication or alignment tolerances. It is also useful to consider weight limitations based on transportation costs, or a clearly defined set of scientific goals which are achievable for particular wavelength regimes. It

is difficult to judge what particular design considerations should be made for an instrument that would be expected to be in operation 20-25 years in the future or even what the most important scientific problems will be in the next century. One set of criteria that will most likely not change significantly with time is that of the signal-to-noise ratio. Here we present some simple arguments that suggest a compromise toward longer wavelengths than have been discussed so far.

We assume that there are detectors available that essentially count photons over the wavelength range from 0.5 to 5.0 μm . We are not suggesting that any single detector would cover that range but that there are detector technologies available to cover it. Photon-counting detectors for longer wavelengths may be available by the time a lunar base exists, but for now we ignore this possibility. Consider now a blackbody source of temperature T . Then, at a frequency ν , the Planck, function is given by

$$B_{\nu}(T) = \frac{2h\nu^3/c^2}{e^{h\nu/kT} - 1}, \quad (1)$$

where B_{ν} has units of $\text{W m}^{-2} \text{Hz}^{-1} \text{ster}^{-1}$. For a given frequency band $\Delta\nu$, which is some fixed fractional bandwidth of the frequency ν , the number of photons per unit time collected by a hypothetical telescope of area A can be shown to be

$$\Gamma_{\text{coll}} = \frac{\kappa\nu^3 A}{e^{h\nu/kT} - 1}, \quad (2)$$

where κ is a constant of proportionality, Let A be a free parameter that may also be scaled with frequency ν according to a power law $A = \gamma\nu^{-n}$, where for the purposes of this discussion we restrict n to be a positive integer or zero. In fact the empirically correct scaling law between telescope area and frequency may not be a simple integer power of the frequency. If we transform to the dimensionless variable $x \equiv h\nu / kT$, we obtain

$$\Gamma_{\text{coll}} = \frac{\gamma\kappa(kT/h)^{3-n} x^{3-n}}{e^x - 1}. \quad (3)$$

The basic idea in scaling the antenna area with frequency is that in almost any conceivable design, there is a compromise between design tolerance such as surface accuracy and telescope

size. A more precise mirror suitable for short wavelengths would generally be smaller than one for longer wavelengths where less precision is needed. It is also generally true that, for a given precision, the total telescope weight scales approximately as the cube of its diameter. So there is a sensible trade-off between telescope area and wavelength up to the point when the total payload weight becomes intolerably large. Thus one expects the suggested scaling law to be valid over a limited frequency range. The specific mirror fabrication technology chosen may determine the relevant area-frequency power law, but one would expect it to be in the range of the three choices $A = \text{const}$, $A \propto \nu^{-1}$, or $A \propto \nu^{-2}$.

A simple physical argument can be used to show why one would expect the area to scale approximately as a simple inverse integer power of frequency. As had been noted by Burke (1985), the deflection s of a beam can be written as

$$s \approx \gamma(\rho/Y) g_m l^2, \quad (4)$$

where s depends on the length of the beam l , on the gravitational constant, g_m , on the Young's modulus Y , on the density ρ , and on the dimensionless geometrical factor γ . If the fractional error tolerance for the mirror is independent of frequency, for example, one usually expects to have a mirror with an rms surface accuracy of $\lambda/10$ or better, where λ is the wavelength; the allowable deflection s would then also be proportional to wavelength, or inversely proportional to frequency. Hence from equation (4), $l^2 \propto \nu^{-1}$, which implies $A \propto \nu^{-1}$. Similar arguments can be constructed for the situation where forces, other than those due to gravity, are distorting the mirror. These forces would tend to give rise to scaling laws within the range encompassed by the integer power law indices 0, 1, and 2.

Figure 7 displays the signal-to-noise ratio in terms of the number of photons collected per second with an arbitrary scale factor as a function of the scaled variable x . The solid curve shows Γ_{coll} for the case when $A = \text{const}$; the short dashed curve is for the case when $A \propto \nu^{-1}$, while the long dashed lines represent a curve for $A \propto \nu^{-2}$. One fact that becomes immediately apparent from these curves is that the maximum value of $\Gamma_{coll}(x)$ is shifted to a lower value of x as n increases. If telescope area is very inexpensive to add, such as when $A \propto \nu^{-2}$, then for a fixed temperature T one is driven toward very low frequencies, indeed to $\nu = 0$. If $A \propto \nu^{-1}$ then Γ_{coll} peaks at $x_{\text{max}} = 1.6$ as compared to the constant area case where $x_{\text{max}} = 2.8$. This suggests an optimum wavelength modestly longer than that suggested by the constant area curve. If we pick a particular frequency,

we can investigate how the signal-to-noise changes with temperature. If we choose a wavelength of $1\ \mu\text{m}$, then the signal-to-noise ratio drops by only a factor of 2 for temperatures between 2,700 K and 12,000 K, as can be determined from the solid curve, i.e., the blackbody curve. The maximum occurs near 5,000 K.

This choice of optimum wavelength allows one to be sensitive to stellar spectral types from the cool M5 dwarfs all the way to hot B5 stars, which covers most of the main sequence as well as most of the red giant branch. Extinction due to interstellar dust is much less at $1\text{-}2\ \mu\text{m}$ than in the visible or UV. For example, some active galactic nuclei, essentially all star-forming regions, the Galactic Center, many late-type stars, and proto-planetary nebulae are enshrouded by dust clouds that are optically thick at visible wavelengths. Clearly the study of these objects would be enhanced by the longer wavelength capability. It may also be useful to consider the construction of more than one array, such as separate arrays, with one optimized for the UV/visible wavelengths, the other for the infrared.

Summary and Conclusions

The Infrared Spatial Interferometer (ISI) is a heterodyne interferometer that operates in the atmospheric window around $10\ \mu\text{m}$. In January 1988 it was installed on Mt. Wilson and the first interference fringes were observed by the ISI in June 1988. An initial data set on a dozen late-type stars was also obtained this observing season, which demonstrated that this interferometer behaves essentially as expected from its design parameters. A preliminary analysis of fringe phase fluctuations shows that the fluctuations are consistent with those observed on the Mark III visible interferometer, also located on Mt. Wilson. The data also demonstrate that high accuracy visibilities can be determined.

We show by simple scaling arguments that a lunar visible/IR synthesis array may be optimized for wavelengths in the near infrared that are somewhat longer than have been proposed previously.

Acknowledgments

We are pleased to thank P. R. McCullough for his assistance with the astronomical observations and data analysis, and for a critical reading of this manuscript. This work was supported in part by the U.S. Office of Naval Research Contract No. N00014-82-C-0700 and grants

from the California Space Institute and the Perkin Fund. One of the authors (WCD) has been supported in part by the L. W. Frohlich Research Fellowship of the New York Academy of Sciences.

References

1. Burke, B. F. 1985. Conference on Lunar Bases and Space Activities of the 21st Century, Lunar and Planetary Institute, Houston, TX, 73.
2. Colavita, M. M.; Shao, M.; Staelin, D. H. 1987. *Appl. Optics*, 26:2106.
3. Danchi, W. C.; Arthur, A.; Fulton, R.; Peck, M.; Sutton, E. C.; Townes, C. H.; Weitzmann, R. H. 1986. Proc. of the SPIE Conference on Advanced Technology Optical Telescopes III, 628:422.
4. Danchi, W. C.; Bester, M.; Townes, C. H. 1988. High Resolution Imaging by Interferometry, F. Merkle, ed., ESO Conference and Workshop Proceedings No. 29 (Garching, FRG:European Southern Observatory):867.
5. Johnson, M. A.; Betz, A. L.; Townes, C. H. 1974. *Phys. Rev. Lett.*, 33:1617.
6. Kingston, R. H. 1978. *Detection of Optical and Infrared Radiation*, (New York: Springer-Verlag), Spears, D. L. 1977, *Infrared Phys.*, 17:5.
7. Thompson, A. R.; Moran, J. M.; Swenson, G. W. 1986. *Interferometry and Synthesis in Radio Astronomy* (New York: John Wiley and Sons, Inc.):185.
8. Townes, C. H. 1984. *J. Astrophys. and Astron.*, 5:111.
9. Townes, C. H.; Danchi, W. C.; Sadoulet, B.; and Sutton, E. C. 1986. Proc. of the SPIE Conference on Advanced Technology Optical Telescopes III, 628:281.

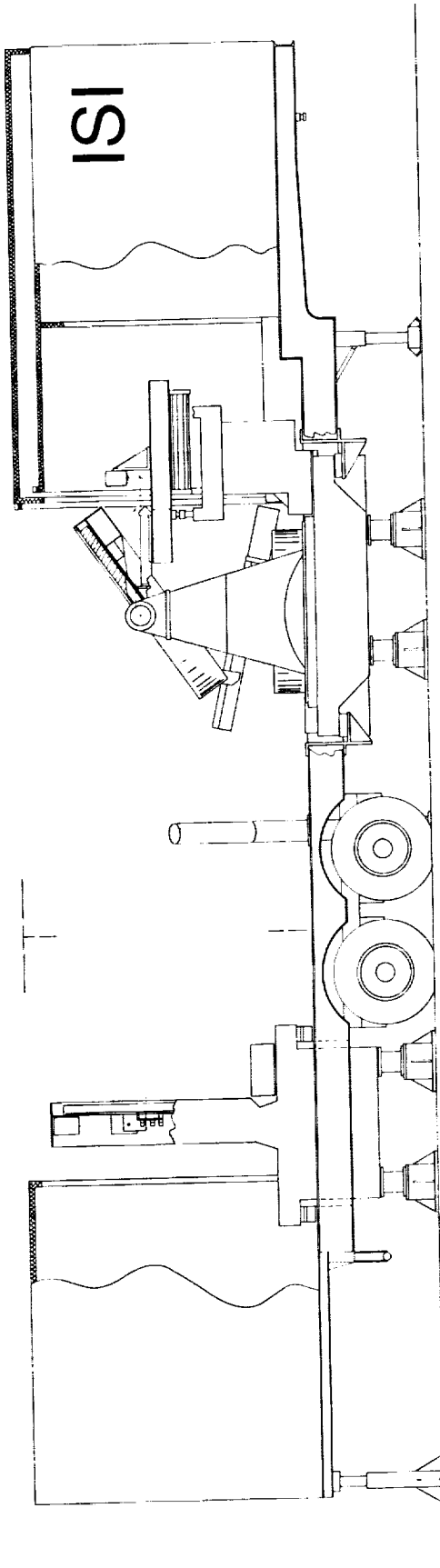

UCB INFRARED SPATIAL INTERFEROMETER
SEMI-TRAILER OUTLINE

1 METER

Danchi et al.

Figure 1: Schematic illustration of one of the Pfund telescopes of the University of California Infrared Spatial Interferometer. Starlight is reflected by the flat mirror on the right of the figure to the parabolic mirror on the left side of the figure. The light is focused by the parabolic mirror through a hole in the flat mirror and is subsequently detected and further processed on an optics table located in a room behind the flat mirror. This mirror is supported by an alt-az mount. The telescope mounts are housed in a standard size semi-trailer and are decoupled from the trailer when observing.

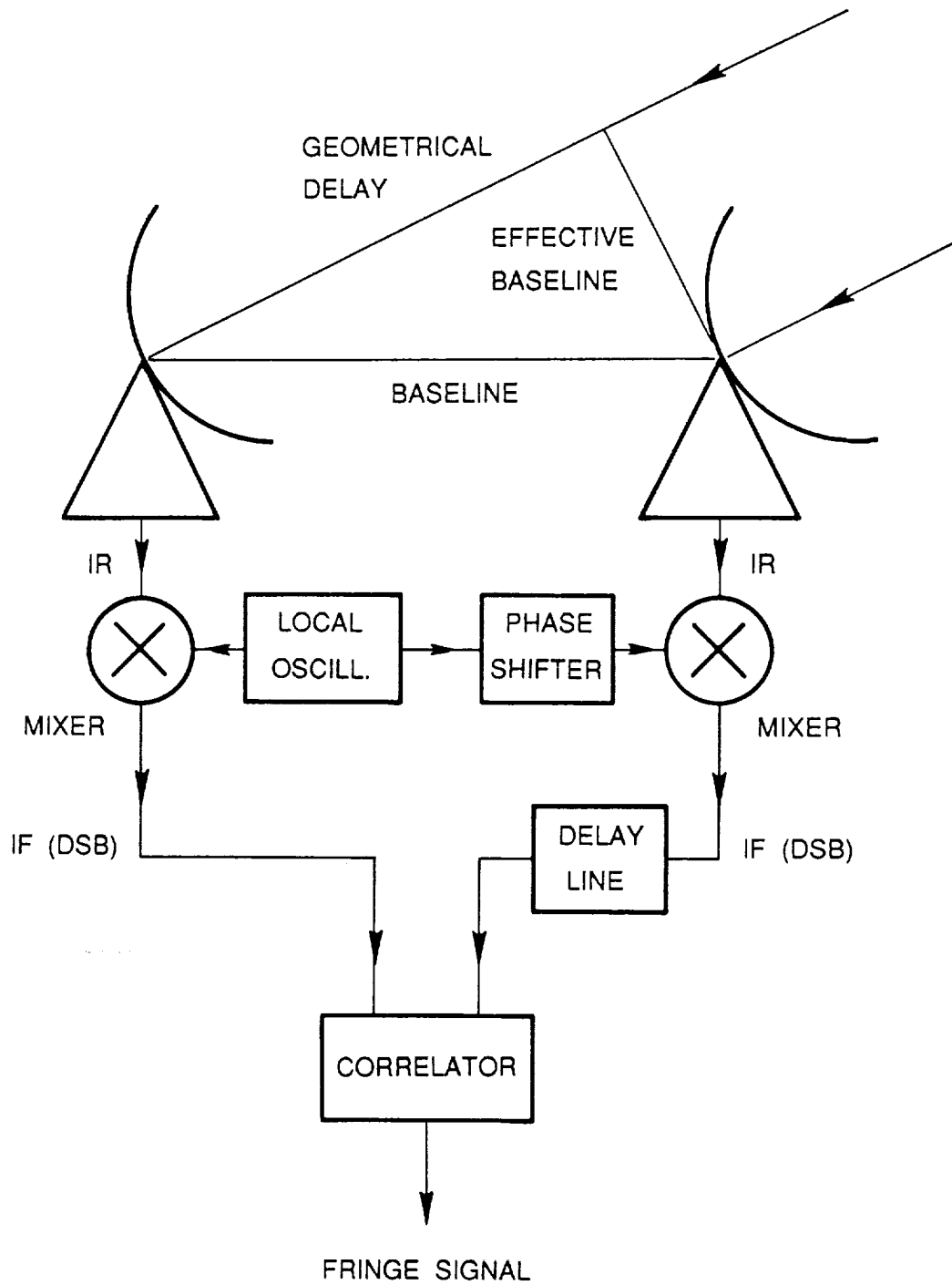

Figure 2: Schematic illustration of the basic heterodyne interferometer upon which the ISI detection system is based.

Danchi et al.

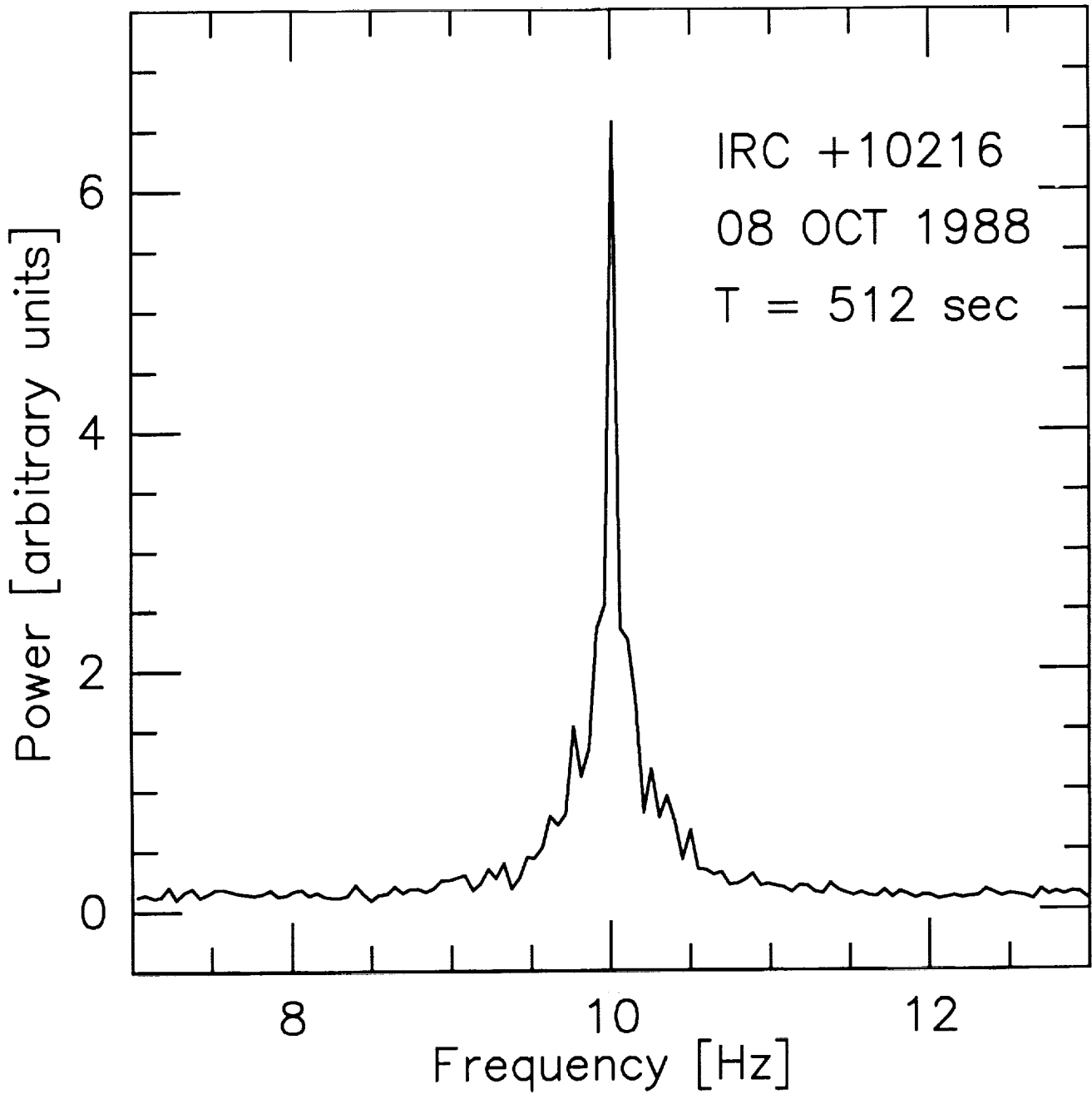

Figure 3: Power spectrum of an interference fringe obtained on IRC +10216 on 8 October 1988 after a 512-second integration time.

Danchi et al.

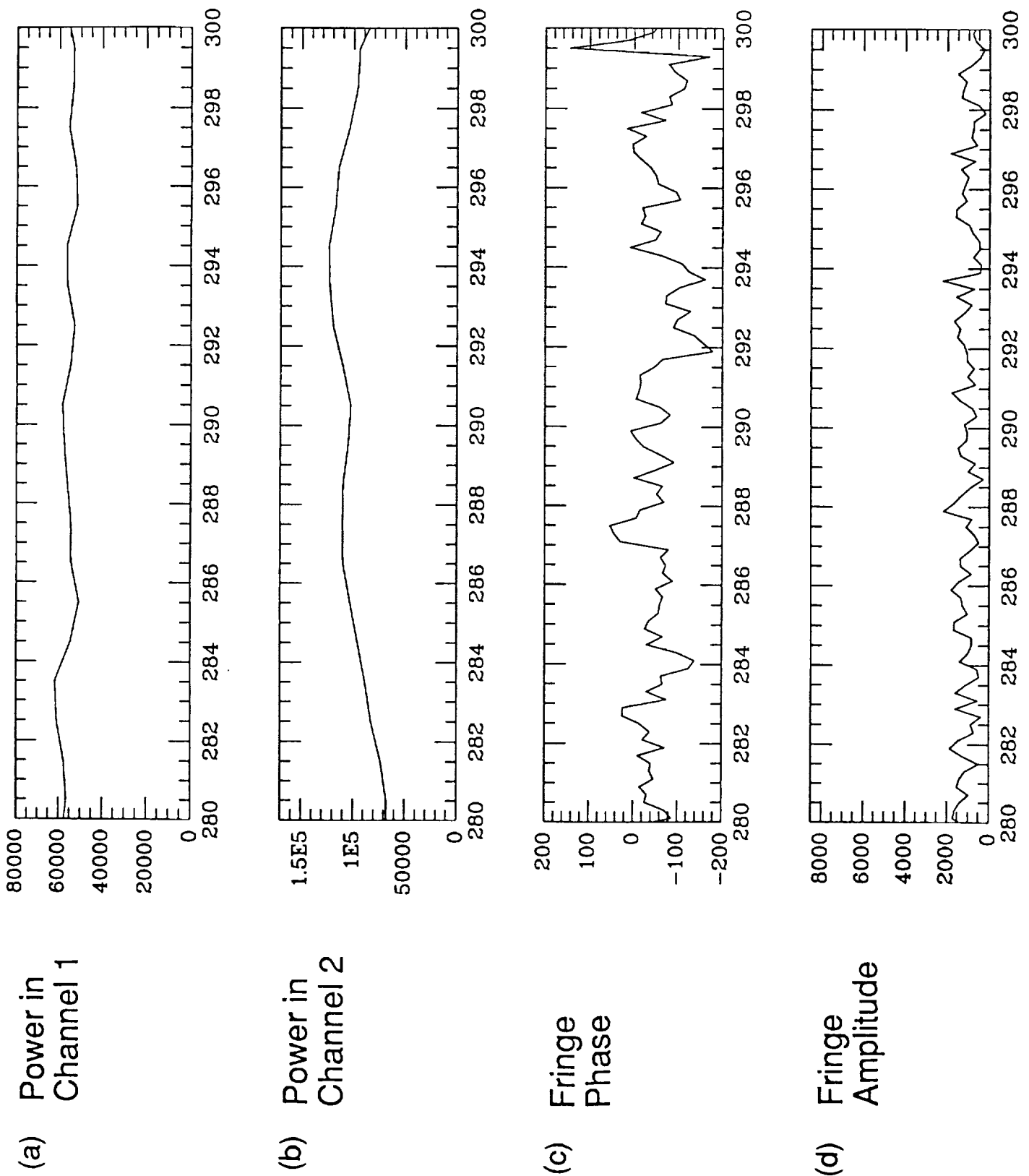

Figure 4: Infrared power in arbitrary units detected by telescope 1 (a) and by telescope 2 (b) of the ISI obtained on IRC +10216 as a function of time in seconds. (c) Phase of the interference fringe measured in degrees obtained in 0.2-second integration time periods. (d) Fringe amplitude in arbitrary units is a function of time in seconds.

Atmospheric Phase Fluctuations

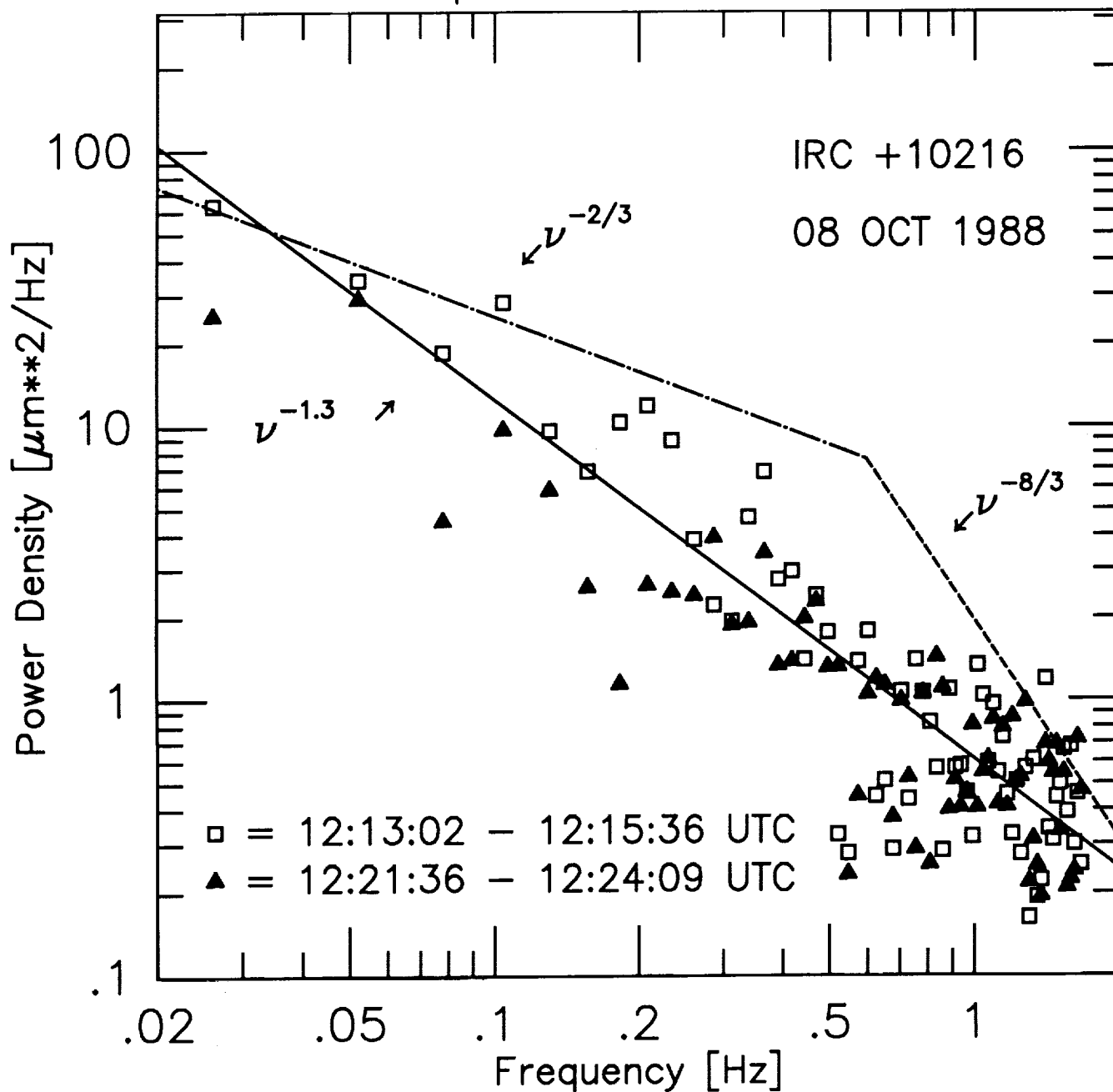
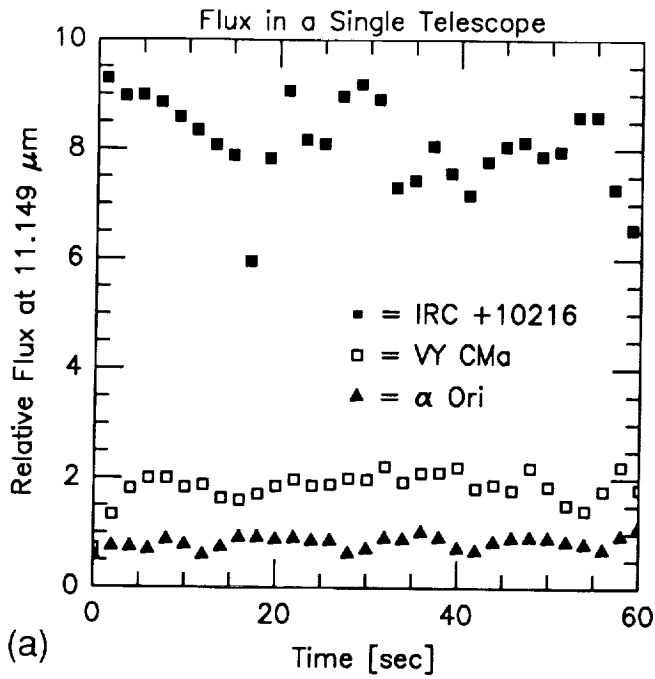
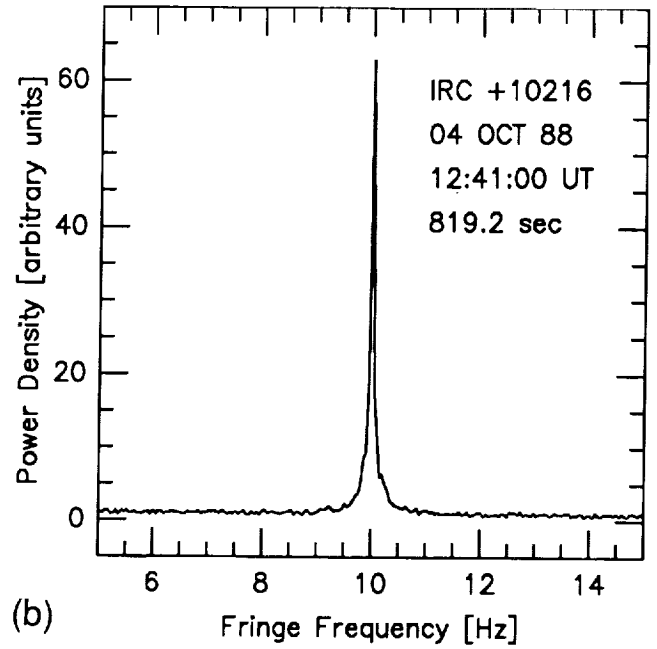

Figure 5: Power spectrum of atmospheric pathlength fluctuations obtained from data like that in figure 4. The data are from two 2.5-minute time periods. The dot-dashed line is the $\nu^{-2/3}$ asymptote and the dotted line is the $\nu^{-8/3}$ asymptote scaled for baseline differences from the data of Colavita et al. (1987).

Danchi et al.



(a)



(b)

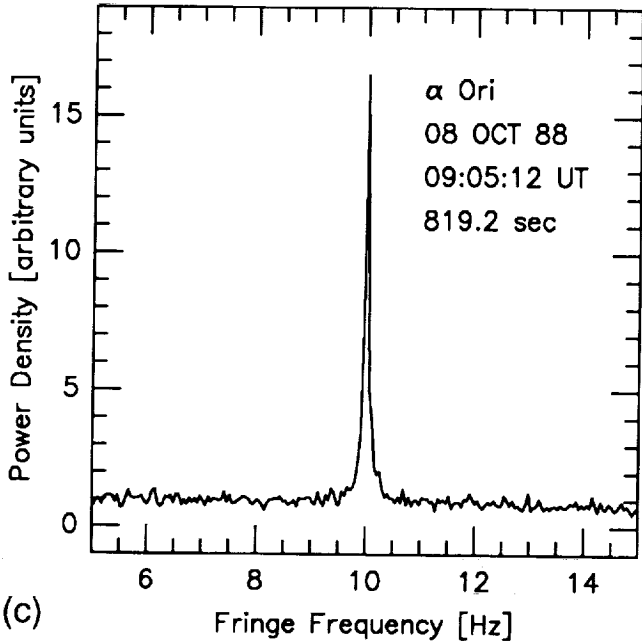

(c)

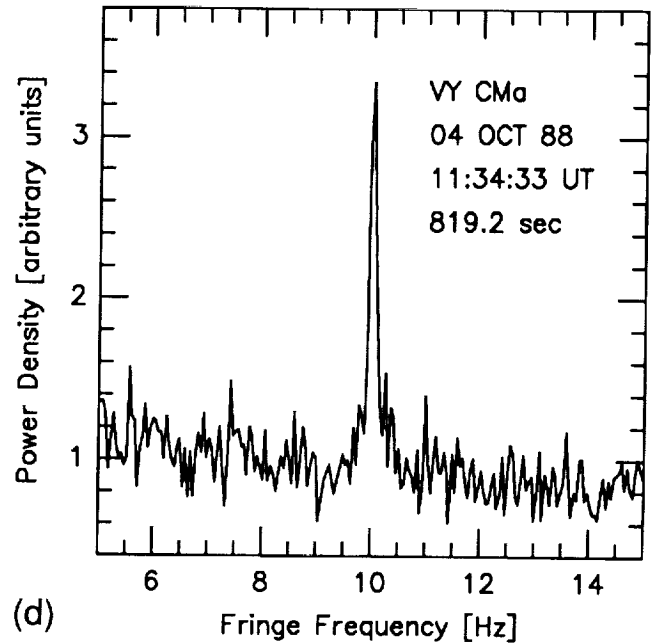

(d)

Figure 6: (a) Measured fluxes in a single telescope for IRC +10216, VY CMa, and α Ori in arbitrary units as a function of time. (b) Fringe power spectrum for IRC +10216 observed on 4 October 1988. (c) Fringe power spectrum for α Ori recorded on 8 October 1988. (d) Fringe power spectrum for VY CMa observed on 4 October 1988. Note that VY CMa has a larger single telescope flux than that of α Ori but it has less power in its interference fringes as compared to α Ori, indicating that we are resolving its dust shell.

Danchi et al.

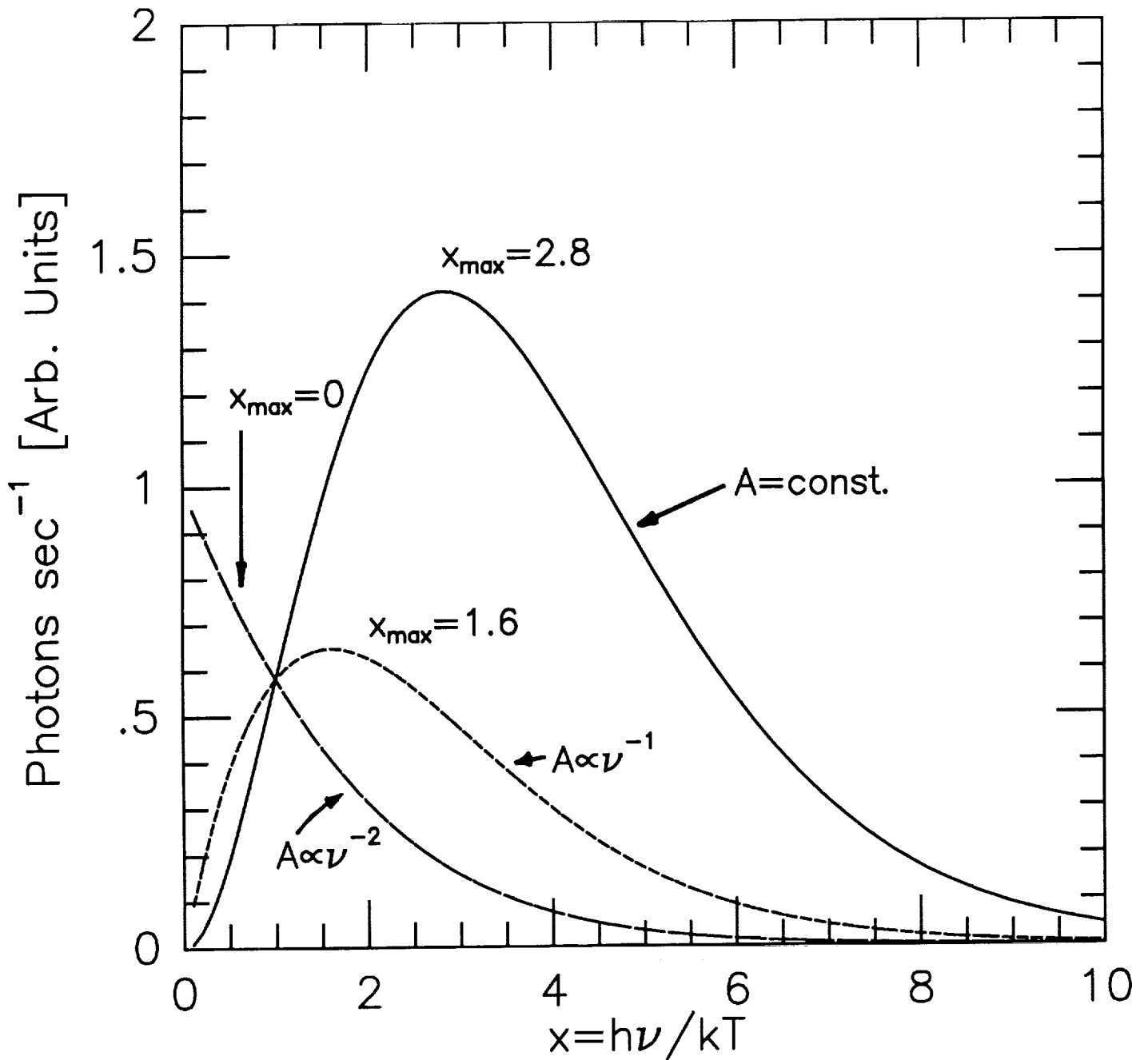

Figure 7: Number of photons per second detected by a telescope of area A with a scaling factor removed as a function of the scaled variable $x \equiv h\nu/kT$. Curves drawn are for different area (A) frequency (ν) scaling relationships, $A \propto \nu^{-n}$. The $n = 0$ case is represented by the solid line, the $n = 1$ case is drawn as the short dashed line, and the $n = 2$ case is shown by the long dashed line. Note that the maximum signal occurs at lower frequencies for a fixed temperature T as the power law index n increases.

Danchi et al.

SHOT NOISE LIMITS TO SENSITIVITY OF OPTICAL INTERFEROMETRY

Sudhakar Prasad

Center for Advanced Studies & Dept. of Physics and Astronomy
University of New Mexico, Albuquerque NM 87131Abstract

By arguing that the limiting noise is the photoelectron shot noise, we show that the sensitivity of image synthesis by an ideal optical interferometer is *independent* of the details of beam-splitting and recombination. The signal-to-noise ratio of the synthesized image is proportional to the square root of the total number of photoelectrons detected by the entire array. For non-ideal interferometers, which are forced to employ a closure-phase method of indirect inference of the visibility data, essentially the same result holds for strong sources, but at weak light levels beam-splitting degrades sensitivity.

Section I: Introduction

A major distinction between synthetic aperture imaging of astronomical objects at radio and at optical frequencies is that for the former the wave noise dominates the photon counting noise while for the latter the reverse holds. This is especially significant since in the optical domain noise-free amplification of the photon number does not seem possible and thus the photon counting noise cannot be reduced simply by amplification. Furthermore, modern photoelectric detectors do not suffer from significant dark currents or other sources of instrument noise. In other words, the sensitivity of optical imaging via aperture synthesis is limited principally by photoelectron shot noise, which is determined solely by the strength of the source and the collecting area of the array.

Here, we have analyzed the signal-to-noise ratio (SNR) and the distribution of noise across the image plane of an optical aperture synthesis array, and the dependence of these quantities on the beam combination geometry. The aperture synthesis method employs the van Cittert-Zernike theorem (Goodman 1985), which states that the object intensity is the two-dimensional Fourier transform of the distribution of spatial coherence in a plane. For a given total collecting area spread over n apertures, there are many different ways of experimentally deducing the spatial

correlation of the light field on the available $n_b \equiv n(n-1)/2$ baselines. The different ways correspond to how the original beams are first split and then recombined. For example, one could split each of the original n beams into $n-1$ sub-beams and recombine r different sub-beams at a time on nC_r different detectors. We shall henceforth call such an array an nC_r array. The two extreme cases of the nC_r array are the nC_2 array, in which the fringes corresponding to the n_b individual baselines fall on n_b separate detectors, and the nC_n array, in which *all* fringes for all baselines fall on a *single* detector. We have analyzed only these two arrays and found that the sensitivity depends only slightly on the details of beam combination. The SNR is found, up to factors of order 1, to be \sqrt{L} where L is the total number of photoelectrons collected by the entire array in the integration time.

Unlike space-based and lunar optical arrays, ground-based arrays are afflicted by the atmospheric phase corruption of astronomical signals. Ground-based arrays thus suffer not only from the photon shot noise but from the more important phase noise of the atmosphere, a fact that forces them to employ a closure-phase method (Baldwin *et al.* 1986) of recovery of spatial coherence data analogous to that in the radio domain (Pearson and Readhead 1984). We have also computed in this report the SNR of the bispectrum, whose phase is the closure phase, for an nC_2 array.

Our work concerns only the analysis of noise coming from the detection of individual fringe phasors, not the noise arising from an incomplete sampling of the spatial frequency plane, since the latter is well understood. In this report we shall only present the most salient results, since these and several others will be derived in detail in a series of papers (Prasad and Kulkarni 1989, Kulkarni, Prasad, and Nakajima *in preparation*) to be published.

Section II: An Ideal nC_2 Interferometer

Let there be n identical principal apertures from which we derive n main beams. Each main beam is divided into $n-1$ identical sub-beams by the use of beam splitters. The resulting $n(n-1)$ sub-beams are combined pairwise on $n_b = nC_2$ identical detectors, each with P pixels. Each detector may thus be identified with one spatial frequency, or baseline. The average photoelectron counts at the pixel \vec{p} of the r th detector is proportional to the average intensity at that pixel and may be written as

$$\langle k_r(\vec{p}) \rangle = 2 \langle K_0 \rangle [1 + \gamma_r \cos(\vec{p}\omega_r + \phi_r)], \quad (2.1)$$

where $\gamma_r e^{i\phi_r}$ is the complex visibility, or spatial coherence, for spatial frequency $\vec{\omega}_r$. Here, $\langle \dots \rangle$ refers to averaging over the photoelectron detection process. The product $p\omega_r$ is to be understood as the scalar product of the pixel position vector \vec{p} and the spatial frequency $\vec{\omega}_r$ expressed in inverse pixel units. If $\langle C \rangle$ is the average number of photoelectrons detected by the entire array in one integration period, then $2\langle N \rangle \equiv \langle C \rangle / n_b$ is the average number of photoelectrons per detector in that period. From equation (2.1), the average number of photoelectrons per detector is equal to $2\langle K_0 \rangle P$ and thus $\langle K_0 \rangle P = \langle N \rangle$.

Each detector yields two fringe phasors: z_r , the spatial frequency component corresponding to the baseline r , and z_r^0 , the photoelectron count or the zero spatial frequency component derived from the fringe pattern on that detector. These quantities are operationally defined by the relations

$$z_r = \sum_{p=1}^P k_r(p) e^{-ip\omega_r}, \quad z_r^0 = \sum_{p=1}^P k_r(p). \quad (2.2)$$

Throughout this article we will use the upper case for the ensemble average of a random variable. There are two different ways by which the synthesized image can be constructed from the visibility data: The first uses only the nonzero spatial frequencies in inversion ("inversion without total photocounts"), while the second uses *all* frequencies including z_r^0 ("true inversion"). Despite the fact that the first method produces *zero* total photon number in the map, it is the standard method in radio astronomy.

We now discuss for the two methods of noise distribution in the maps due to the statistical nature of the photoelectric detection process, which limits the accuracy with which fringe phasors may be measured via relations of kind (2.2). The statistics of the shot noise are Poissonian on account of which the variance in the photoelectron count in pixel p is equal to the average photoelectron count $\langle k(p) \rangle$. In contrast to the sampling errors, which may be CLEANed away (see, e.g., Perley, Schwab, and Bridle 1985), there is no technique by which the effects of shot noise can be reduced. In what follows, we analyze the effect of shot noise on the maximum achievable SNR in the synthesized map.

a. Inversion Without Total Counts. The synthesized image is the real portion of the Fourier transform of the spatial coherence function. On pixel q in the image, its value is

$$i_1(q) = \text{Re} \sum_{r=1}^{n_b} z_r e^{iq\omega_r}. \quad (2.3a)$$

The mean map $I_1(q)$ is given by

$$I_1(q) = \langle N \rangle \sum_r \gamma_r \cos(\omega_r q + \phi_r). \quad (2.3b)$$

The image $I_1(q)$ may be referred to as the "dirty image," since it suffers from errors caused by incomplete sampling of the spatial frequency plane. A synthesized image can be obtained from the dirty image by any one of the popular deconvolution techniques (see Perley, Schwab, and Bridle 1985).

The variance $V[i_1(q)]$ in the synthesized map $i_1(q)$ will clearly involve three kinds of covariances: $\text{cov}[\text{Re}(z_r), \text{Re}(z_s)]$, $\text{cov}[\text{Re}(z_r), \text{Im}(z_s)]$, and $\text{cov}[\text{Im}(z_r), \text{Im}(z_s)]$. Since there is no correlation of the photoelectron shot noise between different detectors or between different pixels of the same detector, and since shot noise has Poisson statistics, one may show that

$$\text{cov}[\text{Re}(z_r), \text{Re}(z_s)] = \text{cov}[\text{Im}(z_r), \text{Im}(z_s)] = \langle N \rangle \delta_{rs}, \quad (2.4)$$

while $\text{cov}[\text{Re}(z_r), \text{Im}(z_s)] = 0$. After some algebra, the variance $V[i_1(q)]$ in the map turns out to be half the total number of photoelectrons intercepted by the entire array: $V[i_1(q)] = \langle C \rangle / 2$.

Furthermore, the variance is independent of the pixel position as well as the object structure. This is certainly a desirable feature of any aperture synthesis technique.

For the specific case of a point source ($\gamma_r = 1$) at the phase center ($\phi_r = 0$), the central pixel in the image, which is indicative of the entire map, has the mean value $I_1(0) = \langle C \rangle / 2$ and hence the SNR

$$\frac{I_1(0)}{\sqrt{V[i_1(0)]}} = \sqrt{\frac{\langle C \rangle}{2}}. \quad (2.5)$$

Indeed, apart from the factor of $\sqrt{1/2}$, this is the SNR expected physically. This variance refers to the image obtained by synthesizing one *single* set of measurements of the n_b phasors. If the measurements were repeated m times then both the image and the variance would be scaled up by m and the SNR in the resulting map would be $\sqrt{\langle L \rangle / 2}$ where $L = \langle C \rangle m$ is the total number of photoelectrons intercepted by the array over the m coherent integration intervals.

b. True Inversion. According to the van Cittert-Zernike theorem, *all* the spatial frequency components must be used to construct the images. In our inversion, we include only *positive* nonzero spatial frequencies as in equation 2.3a. This is a valid procedure, since the corresponding *negative* frequency components are merely their complex conjugates. Thus the zero spatial frequency phasor, which is its own complex conjugate, must be *halved* (or equivalently, all the positive frequency terms *doubled*) before it is included in such an inversion procedure, one that suppresses all nonzero spatial frequencies of one sign. The synthesized image is then specified by

$$i_2(q) = i_1(q) + \frac{1}{2} \sum_r z_r^0, \quad (2.6a)$$

the mean value of which is

$$I_2(q) = \langle N \rangle \sum_r [\gamma_r \cos(\phi_r + \omega_r q) + 1] = I_1(q) + \frac{\langle C \rangle}{2}, \quad (2.6b)$$

which is nonnegative for all q since $\gamma_r \cos(\phi_r + \omega_r q) + 1$ is so for all r .

As before, we estimate the variance due to the shot noise of the detection process. From equation 2.6a it is clear that $V[i_2(q)]$ differs from $V[i_1(q)]$ by terms containing covariances that involve z_r^0 . We shall skip the details of the straightforward algebra and only give the final result:

$$V[i_2(q)] = \frac{3}{4} \langle C \rangle + I_1(q) = \frac{\langle C \rangle}{4} + I_2(q). \quad (2.7)$$

Thus unlike the previous method the variance is no longer uniform across the map, being composed of a fixed amount ($\langle C \rangle/4$) and a variable amount *equal to the dirty image*. Physically this is so since the zero spatial frequency components are highly correlated with the corresponding fringe phasors. This is a general result valid in the radio domain as well (Kulkarni 1989), where at low source strength the fringe phasors are uncorrelated while at high source strength they are correlated. Correspondingly, in the first case the variance is uniform while in the second case it is not.

Again for a point source at the phase center, $\gamma_r = 1$ and $\phi_r = 0$, the mean central pixel in the map is $I_2(0) = \langle C \rangle$ and the corresponding SNR is $\sqrt{8/5} \sqrt{\langle C \rangle/2}$, which represents an enhancement by a factor $F = \sqrt{8/5}$ over the previous case. Henceforth, we refer to F as the "enhancement factor," using it as some kind of figure of merit. Thus, inclusion of the zero spatial frequency improves the SNR but at the expense of a nonuniform variance.

Section III: Ideal ${}^n C_n$ Interferometers

In an ${}^n C_n$ interferometer, all the n_b different fringes lie on top of each other on a single detector. Although equation (2.2) may be used to recover each of the n_b fringe phasors individually, one expects, at first glance, the image synthesis to be rather noisy, since the different fringe phasors are not all uncorrelated. However, our careful analysis proves otherwise and provides, at the same time, insight into improved schemes of imaging. We consider first an ${}^n C_n$ interferometer with no redundancy of baselines and then an ${}^n C_n$ interferometer with maximum possible redundancy. The redundancy of baselines is not of much significance for lunar or space-based arrays, except insofar as it inhibits a rapid coverage of the spatial-frequency plane. We consider both cases because a lot of analytical simplifications that are possible in the former are invalid in the latter. However, we show that in either case the SNR in the map is roughly the same and, in fact, approximately equal to that of an ${}^n C_2$ interferometer.

a. A Fully Nonredundant Mask. Let us consider the general case of a nonredundant mask of n identical apertures, labeled by lower-case roman letters, being illuminated by a source. The classical intensity distribution of the interference pattern by the n apertures translates into the following form for the average photocounts at pixel p of the detector:

$$\langle k(p) \rangle = \langle Q_0 \rangle \left[n+2 \sum_{g < h=1}^n \gamma_{gh} \cos(p\omega_{gh} + \phi_{gh}) \right]. \quad (3.1)$$

Here $\langle Q_0 \rangle$ has pretty much the same meaning as K_0 in Section II. However, since there is no beam splitting, $\langle Q_0 \rangle = (n-1)\langle K_0 \rangle$.

As before, we need to compute the means, variances, and covariances of the fringe phasors, z_{ij} , to estimate the variance in the synthesized image. The mean phasor on the ij baseline (i.e., the baseline connecting aperture i to aperture j) is given by

$$z_{ij} = \langle Q_0 \rangle \sum_p e^{-ip\omega_{ij}} \left[n+2 \sum_{g < h} \gamma_{gh} \cos(p\omega_{gh} + \phi_{gh}) \right], \quad (3.2)$$

while the covariance, of say the real parts of two fringe phasors z_{ij} and $z_{k\ell}$, is given by

$$\begin{aligned} \text{cov}[\text{Re}(z_{ij}), \text{Re}(z_{k\ell})] &= \sum_p \langle k_p \rangle \cos(p\omega_{ij}) \cos(p\omega_{k\ell}) \\ &= \langle Q_0 \rangle \sum_p \left[n+2 \sum_{g < h} \gamma_{gh} \cos(p\omega_{gh} + \phi_{gh}) \right] \cos(p\omega_{ij}) \cos(p\omega_{k\ell}). \end{aligned} \quad (3.3)$$

By writing every cosine as a sum of two exponentials, we have terms in (3.2) and (3.3) that involve all possible combinations of two and three spatial frequencies $\pm \omega_{ij} \pm \omega_{k\ell}$ and $\pm \omega_{gh} \pm \omega_{ij} \pm \omega_{k\ell}$. Contributions from the pixel sum survive only when these frequency combinations vanish. We now impose two nonredundancy conditions on the array: (i) "nonredundancy of baselines," which requires that $\omega_{ij} \neq \pm \omega_{k\ell}$ unless (ij) and (gh) refer to the same baseline and (ii) "nonredundancy of triangles," which requires that

$$\omega_{gh} \pm \omega_{ij} \pm \omega_{kl} \neq 0, \quad (3.4)$$

unless (gh) , (ij) , and (kl) form the sides of a triangle. Thus while the first condition maximally constrains the baselines or vectors in any array, the second condition imposes the maximal nonredundancy condition on triangles. As before, we shall only summarize results. The reader is referred to our paper (Prasad and Kulkarni 1989) for details.

(i) *Inversion Without Total Counts.* Following the formulation in Section IIa we find the mean synthesized image to be

$$\langle I_3(q) \rangle = \langle M \rangle \sum_{i < j} \gamma_{ij} \cos(q\omega_{ij} + \phi_{ij}). \quad (3.5)$$

To evaluate the variance, we first expand it in terms of the covariances of the individual fringe phasors. After long algebra, one obtains the following final expression:

$$V [i_3(q)] = \frac{\langle M \rangle}{2} \left[n n_b + 2(n-2) \sum_{i < j} \gamma_{ij} \cos(q\omega_{ij} + \phi_{ij}) \right]. \quad (3.6)$$

The variance consists of a constant component $n_b \langle C \rangle / 2$ and a comparable variable component. The latter disappears for $n=2$, in consistency with the results of Section II. For a point source at the phase center for which $i_j = 1$ and $j_j = 0$, the SNR of the central pixel turns out to be

$$\frac{I_3(0)}{\sqrt{V [i_3(0)]}} = \sqrt{\frac{\langle C \rangle}{2}} \sqrt{\frac{2n-2}{3n-4}}. \quad (3.7)$$

The enhancement factor $F = \sqrt{(2n-2)/(3n-4)}$ is unity for $n=2$ and steadily decreases to $\sqrt{2/3}$ as the number of apertures increases. Thus this interferometer is not quite as efficient as the nC_2 interferometer.

(ii) *True Inversion.* The mean and the variance of the map constructed by including z_0 are given by appending to equations (3.5) and (3.6) terms that arise from the inclusion of z_0 in the Fourier inversion. One has

$$I_4(q) = \langle M \rangle \left[\frac{n}{2} + \sum_{i < j} \gamma_{ij} \cos(q\omega_{ij} + \phi_{ij}) \right] \quad (3.8)$$

and

$$V [i_4(q)] = \frac{\langle M \rangle}{2} \left[n \left(\frac{1}{2} + n_b \right) + 2(n-1) \sum_{i < j} \gamma_{ij} \cos(q\omega_{ij} + \phi_{ij}) \right]. \quad (3.9)$$

Clearly even for $n=2$, a single nontrivial baseline, the variance is not uniform throughout the map. However, the SNR at the map center for a point source ($\gamma_{ij} = 1, \phi_{ij} = 0$).

$$\frac{I_4(0)}{\sqrt{V [i_4(0)]}} = \sqrt{\frac{\langle C \rangle}{2}} \sqrt{\frac{2n^2}{3n^2 - 5n + 3}}, \quad (3.10)$$

is larger by a factor of $\sqrt{8/5}$, for $n=2$, than for the previous case in which z_0 was excluded. But, as in Section IIIa, for large n the enhancement factor F attains the asymptotic value of $\sqrt{2/3}$.

b. A Maximally Redundant $n C_n$ Interferometer. To demonstrate that the degree of redundancy does not affect the sensitivity of an interferometer in an essential way, we consider here an array of n regularly spaced apertures in a one-dimensional geometry. There are $(n-1)$ distinct spatial frequencies $\omega_0, 2\omega_0, \dots, (n-1)\omega_0$, where ω_0 is the spatial frequency of the baseline connecting two successive apertures. Clearly the spatial frequency $r\omega_0$ ($1 \leq r \leq n-1$) is $(n-r)$ -fold redundant.

For simplicity, consider the case of a point source at the phase center. The average photoelectron count is given by

$$\langle k_p \rangle = \langle Q_0 \rangle \left[n + 2 \sum_{r=1}^{n-1} (n-r) \cos(pr\omega_0) \right]. \quad (3.11)$$

The fringe phasor z_r for spatial frequency $r\omega_0$ has the mean value

$$\langle z_r \rangle = \langle M \rangle (n - r) \quad (3.12)$$

We need to calculate the covariances of the real and imaginary parts of z_r to estimate the variance in the image. As before, we suppress the details of algebra and only present the final results for the map, made first without the zero spatial frequency and later with it. The results are at this stage still quite opaque and we, therefore, restrict even further to considering only the central pixel in the image.

(i) *Inversion without Total Counts.* At the phase center, the mean and variance are

$$I_5(0) = \langle C \rangle \frac{(n-1)}{2}, \quad (3.13)$$

$$V[i_5(0)] = \frac{\langle C \rangle}{12} [5n^2 - 9n + 4], \quad (3.14)$$

leading to an SNR at the phase center of amount

$$\frac{I_5(0)}{\sqrt{V[i_5(0)]}} = F \sqrt{\frac{\langle C \rangle}{2}}, \quad (3.15)$$

where $F = \sqrt{6n - 6/(5n - 4)}$ is our enhancement factor. For $n=2$ we find $F=1$ while the value of F in the limit of large n is $\sqrt{6/5}$.

(ii) *True Inversion.* Including the zero spatial frequency component in the Fourier inversion, we obtain the following mean and variance at the central pixel:

$$I_6(0) = \langle C \rangle \frac{n}{2}, \quad \text{and} \quad V[i_6(0)] = \frac{\langle C \rangle}{12} [5n^2 - 3n + 1], \quad (3.16)$$

Thus the SNR at the phase center is $F \sqrt{\langle C \rangle / 2}$ where F , the enhancement factor, is

$$F = \sqrt{\frac{6n^2}{5n^2 - 3n + 1}} \quad (3.17)$$

For $n=2$, by including z_0 in the reconstruction process, F has been enhanced from 1 to $\sqrt{8/5}$. The limiting value of F for large n is $\sqrt{6/5}$.

In figure 1 we display our results for the enhancement factor F of the SNR as a function of the number of array elements for all six interferometers considered so far. What is most striking about the graph is that the SNR is more or less independent of the details of the array, whether it is ${}^n C_2$ or ${}^n C_n$ or whether it is redundant or not. The sensitivity of ideal Michelson interferometers is limited solely by the *total* number of photoelectrons detected by the *entire* array and not by how individual beams are combined on the detectors. Thus, if detectors are limited only by the photoelectron counting noise, then the sensitivity of an ${}^n C_r$ array should be qualitatively independent of r , the number of sub-beams per detector.

Section IV: An ${}^n C_2$ Ground-Based Array

A *direct* determination of the visibility phasors with ground-based synthetic aperture arrays is nearly impossible due to the phase corruption of the incident optical signals by the atmosphere. One must employ of closure-phase method of indirectly inferring the visibility data from estimators called variously as "triple products," "bispectra," etc. (Wirnitzer 1985, Baldwin *et al.* 1986). A bispectrum b refers to a set of three apertures, say i, j, k , and is defined as the product of the complex fringe phasors on the three baselines ij, jk , and ki that form the sides of the triangle with vertices i, j, k . The random phases contributed by the atmosphere at different apertures exactly cancel each other in the complex phase, the so called closure phase, of any such triple product.

We consider an ${}^n C_2$ array which has in all $n_t \equiv n C_3$ triple products only $n_b = {}^n C_2$ independent baselines. Thus not all triple products are independent. Furthermore, there is no analytical procedure by which the complex phasors can be exactly computed from the triple-product

data. There are iterative numerical schemes developed in the radio regime (Pearson and Readhead 1984), which may also be used in the optical regime to accomplish this approximately.

For a point source the only parameter that can be analytically inferred from the triple products is the source flux F . An estimate of F is $S^{1/3}$ where

$$S = \sum_{s=1}^{n_t} b_s. \quad (4.1)$$

We argue that the SNR of F is a good indicator of the SNR of the map inferred numerically from the bispectrum data. Clearly, the SNR of F is three times the SNR of S . In what follows, we restrict our discussions to a point source at the phase center of the array. For this case, all bispectra are equivalent just as all fringe phasors are.

To compute the SNR of F , we first compute the covariances of the individual triple products, b_s . Each b_s is correlated with itself as well as with the $3(n-3)$ other triangles that share *one* side with it. Let σ_b^2 and $\mu\sigma_b^2$ represent the self-correlation (variance) and cross-correlation (covariance) of the bispectra. Then

$$\text{SNR}(F) = \frac{3n_t \langle N \rangle^3}{\sqrt{n_t \sigma_b^2 + 3(n-3)n_t \mu \sigma_b^2}}, \quad (4.2)$$

where we have used the fact that all the fringe phasors are independent of one another for an nC_2 array and each have the average value $\langle N \rangle$. It is not too hard to show (Kulkarni, Prasad, and Nakajima *in preparation*) that

$$\sigma_b^2 = 6\langle N \rangle^5 + 12\langle N \rangle^4 + 8\langle N \rangle^3 \quad \text{and} \quad \mu\sigma_b^2 = 2\langle N \rangle^5. \quad (4.3)$$

Thus the final expression of SNR (F) is

$$\text{SNR}(F) = \frac{3 \sqrt[3]{n_t \langle N \rangle^3}}{\sqrt{6(n-2) \langle N \rangle^5 + 12 \langle N \rangle^4 + 8 \langle N \rangle^3}} \quad (4.4)$$

(i) *High-Photon-Number Limit:* $\langle N \rangle \gg 1$. The SNR of the measured source strength tends in the limit $\langle N \rangle \gg 1$ to the value $\sqrt{\langle C \rangle / 2}$. This is essentially the same SNR as attainable in ideal imaging considered in Section IIa. Thus, in the high-photon-number limit, imaging sensitivity is limited solely by the total photon number intercepted by the array, not by the details of the imaging algorithm.

(ii) *Low-Photon-Number Limit.* $\langle N \rangle \ll 1$. For very weak source strengths, the SNR of F tends to the value $\sqrt{9n(n-1)(n-2)\langle N \rangle^3 / 48}$. In terms of the $\langle M \rangle$, the number of photons per primary beam, ($\langle N \rangle = \langle M \rangle / (n-1)$) this expression reduces to $3\langle M \rangle^{3/2} / \sqrt{48}$ for a large number n of apertures. In this double limit, therefore, the SNR depends only on the number of photons collected by a *single* aperture and not by the entire array.

Nakajima (1988) has shown that if the primary beams are not split and recombined, then the SNR of F is much greater than the preceding result at low photon numbers. Thus, at low photon numbers, beam splitting is a distinct detriment to the sensitivity of ground-based interferometers using the closure-phase method of triple products.

Section V: Discussion

In this work, we have studied the dependence of the sensitivity and of the distribution of noise across the image plane of an optical interferometer on the details of beam splitting and recombination. Of the many possibilities, we have studied two extreme cases: (i) the so called ${}^n C_2$ interferometer in which the beam from each element is split equally into $n-1$ sub-beams and the resulting $n(n-1)$ sub-beams combined pair-wise onto $n_b = {}^n C_2$ detectors and (ii) an ${}^n C_n$ interferometer in which all the beams are combined on one detector. Our most important result is that up to factors of order 1 the SNR in the *directly* synthesized image for either kind of array is equal to $\sqrt{\langle L \rangle / 2}$ where $\langle L \rangle$ is the total number of photoelectrons collected by the array. Thus the beam combination geometry should *not* be a critical issue in the design of a space interferometer.

Direct synthesis is not possible for ground-based arrays that suffer from atmospheric phase aberrations, and one must use the closure-phase method of *indirect* computation of the visibility data. We have looked at a nominal SNR for measurements from an ${}^n C_2$ array and found the physically reasonable result that at high photon numbers both direct and indirect imaging are

equally sensitive. However, at low photon numbers the sensitivity depends only on the photon number collected by each aperture and not by the entire array.

This work was done entirely in collaboration with S.R. Kulkarni at Caltech, who had most of the early ideas.

References

1. Baldwin, J. E; Haniff, C.A.; Mackay, C.D.; Warner, P.J. 1986. *Nature* 320:595.
2. Goodman, J.W. 1985. *Statistical Optics*, (Wiley:New York).
3. Kulkarni, S.R. 1989. *sub. to Astron. J.*
4. Kulkarni, S.R.; Prasad, S.; Nakajima, T. *in preparation.*
5. Nakajima, T. 1988. *J. Opt. Soc. Am.* A5:1477
6. Pearson, T.J.; Readhead, A.C.S. 1984. *Annu. Rev. Astron. Astrophys.* 22:97.
7. Perley, R.A.; Schwab, F.R.; Bridle, A.H. 1985. *Synthesis Imaging*, (NRAO:Socorro).
8. Prasad, S; Kulkarni, S.R. 1989. *J. Opt. Soc. Am.* A6:1702.
9. Wirnitzer, B. 1985, *J. Opt. Soc. Am.* A2:14.

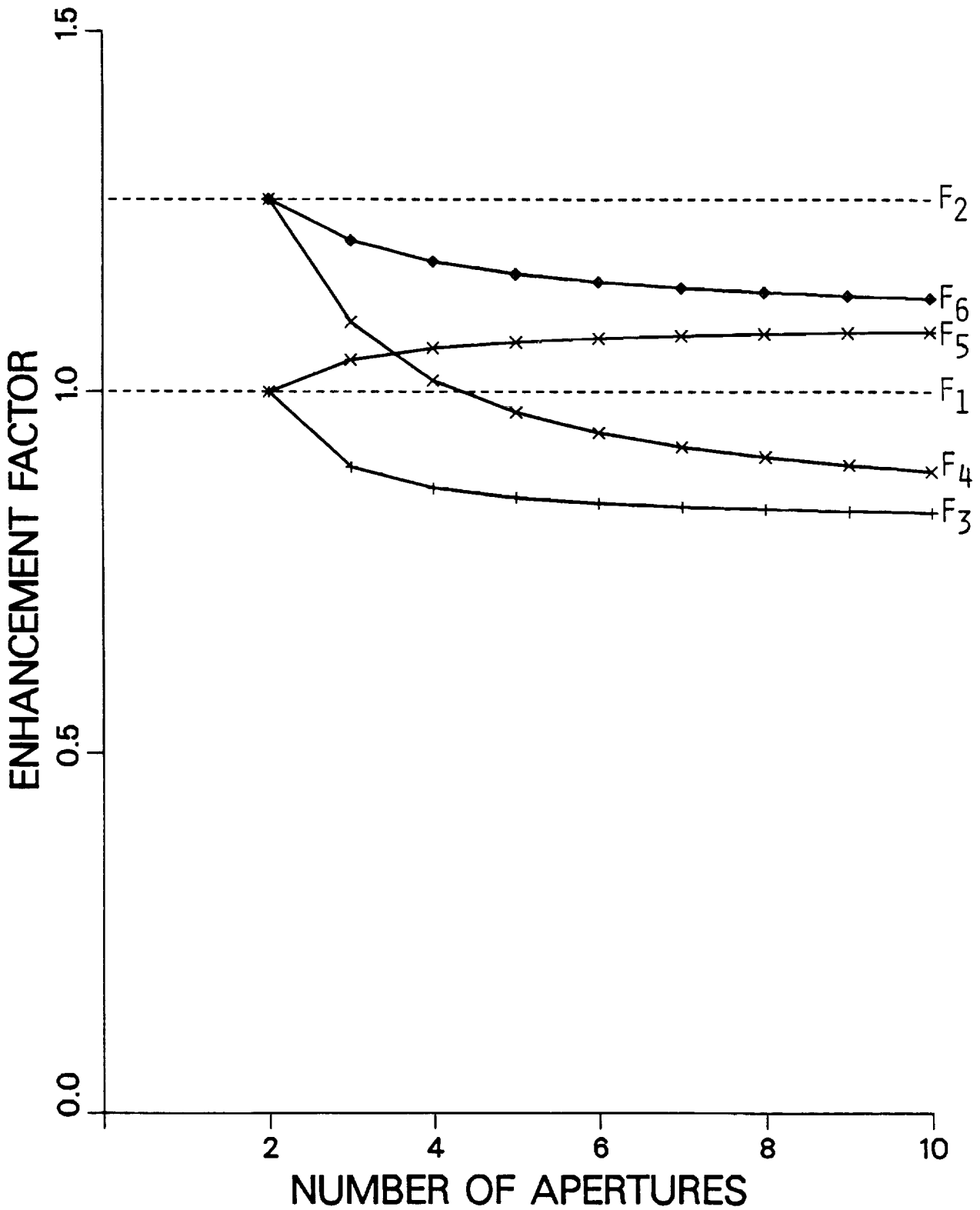

Figure 1: Enhancement factor F of SNR versus the number n of apertures in the array. F_1 and F_2 refer to the ${}^n C_2$ array without and with the zero frequency, F_3 and F_4 refer to the nonredundant ${}^n C_n$ array, and F_5 and F_6 refer to the maximally redundant ${}^n C_n$ array.

PART III
SPACE-BASED INTERFEROMETERS

This section of the proceedings is devoted to discussions of recent proposals for Earth-orbiting optical/IR interferometers. Before building a long-baseline optical interferometer on the Moon, we must first gain experience on short-baseline arrays in space. These papers describe innovative ideas for orbiting interferometers, the technical challenges, and the science drivers.

M. Shao begins with a brief discussion of the technical requirements and performance of a first-generation space interferometer, with particular emphasis on OSI, a project for the Space Station. Pierre Bely and colleagues next describe HARDI, a high-angular-resolution deployable interferometer for space, that will have a 6-meter baseline and thus greatly improve the resolution of the Hubble Space Telescope (HST). The support and servicing of large observatories in space, based on experience with HST, is summarized by T.E. Styczynski. The final paper by S.T. Ridgway serves as a bridge between Parts III and IV of these proceedings by describing the science drivers and technical requirements for interferometers in Earth-orbit and on the Moon.

ORBITING SPACE INTERFEROMETER (OSI):
A FIRST GENERATION SPACE INTERFEROMETER

Michael Shao

Jet Propulsion Laboratory
Optical Sciences, 169-214
4800 Oak Grove
Pasadena, CA 91109

Abstract

This paper discusses the technical requirements and performance of a first generation space interferometer. The performance of an interferometer, sensitivity, field of view, dynamic range, astrometric accuracy, etc, in space is set by what cannot be achieved for a ground-based instrument. For the Orbiting Space Interferometer (OSI), the nominal performance parameters are 20 mag sensitivity, field of view of approximately 500*500 pixels, a 1000:1 dynamic range in the image with one millarcsec resolution, and an astrometric accuracy of 0.1 milliarcsec for wide angle astrometry and 10 microarcsec accuracy for narrow field astrometry (few degrees). OSI is a fully phased interferometer where all critical optical paths are controlled to 0.05 wavelengths. The instrument uses two guide interferometers locked on bright stars several degrees away to provide the spacecraft attitude information needed to keep the fringes from the faint science object stable on the detector.

Introduction

A number of long-baseline stellar interferometers have been built in the recent past. One of them, the Mark III interferometer on Mt. Wilson, is a fully automated instrument that is now routinely used for astronomical observations. A number of new long-baseline interferometers are in the early stages of construction. All ground-based instruments suffer the effects of a turbulent atmosphere. For high-angular-resolution instruments, the parameters that characterize the atmosphere are the coherence diameter, r_0 , linear scale over which the wavefront can be considered flat to 1/6 of a wavelength; the coherence time, t_0 , the time interval over which the phase fluctuations of the atmosphere can be considered frozen; and the isoplanatic angle, the angular

extent in the sky over which the atmospheric phase fluctuations are correlated. Typical numbers for these three parameters are $r_0=10\text{cm}$, $t_0=10\text{ msec}$ and $a_0=4\text{ arcsec}$. These three numbers limit the performance of all ground-based stellar interferometers severely.

The three atmospheric turbulence parameters all get larger at infrared wavelengths at the $6/5$ power of the wavelength. In the thermal infrared, it is expected that active optics techniques will be able to operate as if there were no atmosphere as far as high angular resolution observations are concerned. The role of space-based interferometers lies in the visible and ultraviolet, where operation in space would bring dramatic improvements.

OSI

A more detailed description of the Orbiting Space Interferometer (OSI) for the space station is in the appendix. Only a brief description is given here.

The initial concept for the OSI is a set of three interferometers with 30-50 cm collecting apertures along one 10-20 m structure. Two of the interferometers (guide) are responsible for stabilizing the platform while the third performs the measurements of scientific interest. The guide interferometers will determine the orientation of the platform to 0.25 mas while the laser metrology system will ensure that the internal instrument alignment will also be stable to 0.25 mas.

The OSI will have two modes of observation: astrometric and imaging. In the astrometric mode the relative positions of objects will be determined over large (>30 degrees) and small angles (<3 degrees). For a 30-cm aperture, the photon-noise-limited astrometric precision is 0.02 mas for 1000 sec of integration on a 20th magnitude object. We expect systematic errors to always dominate the achievable accuracy. For small angle measurements the precision is expected to be approximately 0.01 mas, while large angle measurements are expected to be a factor of 10 worse. Numerous stars will be sequentially observed in this mode.

Since all three interferometers will have the same size apertures, they are interchangeable with regard to guide and science functions. This feature provides the OSI with different baselines for imaging. Additional baselines are obtained by tilting (foreshortening) and rotating the

interferometer around the vector dimensional image of the object, and can be constructed with angular resolution ranging from about 2 to 50 mas. These concepts are illustrated in figure 1.

The OSI baseline concept is based on the experience gained in the design, construction, and operation of the Mark III interferometer. Several characteristics of the OSI concept result in a significant reduction of risk or increase in performance over other space-based interferometer designs. One is the use of guide interferometers.

An interferometer in space can either be rigid, structurally rigid and pointed at the target with diffraction limited precision, or floppy. With a number of large ground-based interferometers in operation or in the construction phase, it has become evident that a floppy interferometer in space would not have the gain in performance that would justify the increased cost of a space instrument. At the very least, the information on structural deformations and pointing errors must be available so that the deformations and pointing errors must be available so that the fringe data can be analyzed as if the interferometer was rigid.

Technology Requirements

To take advantage of space-based operation, the interferometer must make use of the lack of a turbulent atmosphere. Although r_0 , the coherence length, is infinite in space, the use of arbitrarily large collecting optics is limited by cost. Although there is no atmosphere, if the structure vibrates or cannot be pointed with sufficient precision, the coherence time of the spacecraft will limit sensitivity in the same way a turbulent atmosphere will. High sensitivity at low cost requires the use of moderate sized optics and a very stable structure that can be pointed with extreme precision.

As part of a larger effort to understand large controlled space structures, the JPL Control Structures Interaction (CSI) effort has chosen as a mission focus a long baseline stellar interferometer based on OSI. A part of this effort includes a detailed instrument definition, and a mission operations definition. With an instrument and operational scenario defined, the CSI effort will develop the technology to build and control a large space structure with the 10 nanometer stability needed for interferometry.

A preliminary analysis of the types of structural noise in a spacecraft was performed by putting the Hubble Space Telescope momentum wheels on the truss for OSI, a 20-m graphite epoxy truss with the lowest resonance at around 10Hz. It was found that vibrations due to the momentum wheel produced displacements of a few microns at a few hertz at the end of the truss. The net result is that the coherence time of a totally uncontrolled and passive structure is a few milliseconds, compared to 10 msec for the turbulent atmosphere.

CSI technology has at its disposal a large bag of tricks such as passive isolation of the noise source (momentum wheel), passive isolation of the optics critical for interferometry, use of balanced actuators that do not change the momentum or angular momentum of the structure when they move, as well as active structural members etc. Very large reductions of structural noise is possible with active systems.

Key to active systems is a laser metrology system that can measure the nanometer level displacements that will affect the optical path of the starlight. As part of our ground-based astrometric interferometry, we have developed a number of optical trusses based on laser interferometers that can be adapted for space. One such laser metrology system is now being analyzed by the JPL CSI effort for their focus Michelson interferometer (FMI), their version of OSI. It is the opinion of the JPL CSI group that the requirements needed for interferometry are not that hard.

Limitations of Orbiting Interferometers

In addition to internal stability, a technological question that is being addressed by CSI, external stability (attitude control) is also required. OSI is using two guide interferometers to look at nearby bright 11-15 mag guide stars to determine spacecraft attitude to a fraction of the resolution of the interferometer (to 0.1 milliarcsec (mas)). As interferometer baselines increase, the attitude control requirements will increase. The problem of accurate attitude control comes from the relativistic effect called stellar aberration.

The use of bright guide stars for attitude control assumes that the positions of the stars are constant with time. Because of spacecraft orbital motion, the apparent position of a star could be as much as 5 arcsec away from its true position. The magnitude of the effect is v/c radians where v is the velocity of the spacecraft and c the speed of light. There is an effect for the Earth's motion around the sun but the Earth's orbital motion is known with very high precision, including the

effect of the Moon and the planet Jupiter. Spacecraft orbital motion must be known to 1 m/sec for a 20-m interferometer using guide stars within 0.1 radian of the science object. By using a GPS receiver on the spacecraft, the velocity can be determined to 10 cm/sec. Hence, without too much trouble, orbiting interferometers with 200 ms baselines are feasible. For interferometers much longer than 200-ms, another method for determining spacecraft orbital velocity is needed. One possibility is to add several interferometers to the instrument to measure the stellar aberration in real time. Other schemes are possible but all of them will significantly increase the complexity of the interferometer.

Science as a Driver

Whenever technology provides an increased measurement capability such as a new wavelength of observation, higher sensitivity or, in the case of stellar interferometers, higher angular resolution, new phenomena are observed. In our observations with the Mark III interferometer on Mt. Wilson, we have resolved double stars that were not resolved by speckle interferometry on 4- and 5-m telescopes. But even our current 32-m baseline is insufficient for some science objectives. In one case, we have easily resolved a spectroscopic binary with a maximum separation of 66 mas and a minimum separation of 4-5 mas (the other side of a very eccentric orbit). The stars themselves are expected to have diameters of the order of 1 mas. With another factor of 2 increase in baseline, the stellar disks would be clearly resolved. In this case, the orbits of the two stars are close enough that we would be able to observe the tidal distortion of the stellar photospheres. Hence, we are in the process of building a six-element 200-m array.

Stellar interferometers are a class of instruments with which (without new technology, hence, modest cost increases), one can obtain orders of magnitude increase in angular resolution that will give us a much clearer picture of a large number of astronomical objects.

HARDI: A HIGH ANGULAR RESOLUTION DEPLOYABLE INTERFEROMETER FOR SPACE

Pierre Y. Bely*

Space Telescope Science Institute
Baltimore, Maryland, 21218

Christopher Burrows*

Space Telescope Science Institute
Baltimore, Maryland, 21218

François Roddier

Institute for Astronomy
Honolulu, HI, USA

Gerd Weigelt

Max Planck Institute fuer Radioastronomie
Bonn, FRG

Abstract

We describe here a proposed orbiting interferometer covering the UV, visible, and near-IR spectral ranges. With a 6-m baseline and a collecting area equivalent to about a 1.4 m diameter full aperture, this instrument will offer significant improvements in resolution over the Hubble Space Telescope, and complement the new generation of ground-based interferometers with much better limiting magnitude and spectral coverage. On the other hand, it has been designed as a considerably less ambitious project (one launch) than other current proposals. We believe that this concept is feasible given current technological capabilities, yet would serve to prove the concepts necessary for the much larger systems that must eventually be flown.

* Affiliated to the Astrophysics Division, Space Science Department, European Space Agency.

The interferometer is of the Fizeau type. It therefore has a much larger field (for guiding) better UV throughput (only 4 surfaces) than phased arrays. Optimize aperture configurations and ideas for the cophasing and coalignment system are presented. The interferometer would be placed in a geosynchronous or sunsynchronous orbit to minimize thermal and mechanical disturbances and to maximize observing efficiency.

Introduction

Observational optical astronomy is always scientifically driven to develop telescopes with fainter limiting magnitudes and higher resolution. However, it is clear that these two goals cannot be pursued simultaneously anymore. Larger ground-based telescopes have much greater collecting area but provide little improvements in resolution unless extremely demanding techniques are used. Space-based telescopes of traditional configuration such as the Hubble Space Telescope (HST) give great improvement in resolution (being diffraction limited), and a consequent improvement in limiting magnitude, but further improvements are limited by launch constraints. It is probably going to be impossible to launch a filled aperture telescope that gives an order of magnitude improvement in resolution over HST for the foreseeable future.

To achieve still higher resolution, interferometers are the answer. On the ground, baselines can be very large, but the atmosphere restricts integration time and therefore limits magnitude. A space-based interferometer, on the other hand, is not limited by integration time and thus could reach much fainter objects. Furthermore, a space interferometer, although likely to be limited in baseline initially, gets improved resolution from operation in the UV. (Near the Lyman continuum, a space interferometer will have about 4 times the resolution obtained from the ground in the U band with the same baseline.)

Many concepts for space-based interferometers have been proposed, but they are generally of major proportions, with baselines of 15 m or more that will require extensive technological development. We believe that the technical feasibility of space interferometry must be demonstrated before projects of this magnitude can be initiated. A smaller interferometer with a baseline on the order of 6 m would be less ambitious than the current generation of proposals and might consequently somewhat limit the science on which they are based. On the other hand, it would be much lower in cost, risk, and development time, and would serve as a stepping stone to the larger projects. The validation in space of enabling technologies in areas such as deployment, active optics, laser metrology, vibration suppression, high accuracy guiding, and pointing, would

be a major technological spinoff from such a project. Such validation is essential if the larger proposed projects are to be demonstrably feasible.

As shown in figure 1, even an interferometer of such a moderate size would offer important advances over both HST and ground-based interferometers, especially if it can be operated in the UV. For example, this would allow bright quasars, Seyfert galaxies, or stellar chromospheres at Lyman alpha to be imaged at several times the resolution of HST. For several scientific areas, the resolution of HST is just marginally inadequate (e.g., imaging the narrow emission line region in a variety of QSOs). Clearly, also, it will often be necessary to pursue the study of discoveries made with HST and the new large ground-based facilities at higher resolution.

We present here a first attempt at defining the main characteristics of an instrument corresponding to this rationale. We call this instrument "HARDI", for High Angular Resolution Deployable Interferometer. We also describe the various configurations and technological options that we plan to examine in detail as part of our ongoing preliminary study of the instrument.

Aperture Configuration

The optimal aperture configuration of an interferometer depends on a number of factors such as scientific goals, complexity of the observed objects, synthesized points spread function, deconvolution, speckle or phase closure techniques, and practical constraints. To determine the best configuration for our proposed instrument and scientific applications, we plan to do a comparative study of three typical configurations. The three aperture configurations, labelled Type I, II, and III have an outer diameter of 6 m and are very diluted with less than 6 percent filling factor.

Type I is composed of six 40-cm-diameter mirrors on six arms and a 1-m-diameter mirror on axis (5.4 percent fill factor). The aperture configuration is highly redundant with the intention of supplying a high signal-to-noise ratio (SNR) ^{1,2}.

Type II is a pupil function proposed by Cornwell³. It contains nine 40-cm-diameter mirrors arranged on a circle with a 2.8 m radius (4 percent fill factor). Its advantage is excellent instantaneous UV plane coverage which could have applications in the observation of ephemeral phenomena or microvariabilities.

Type III offers complete coverage of the UV plane by aperture synthesis. It is composed of six 60-cm mirrors (6 percent fill factor) arranged in such a fashion as to lead to a quasi uniform uv plane coverage when the entire telescope is rotated half a turn around its optical axis.

Type III has not been described elsewhere to our knowledge. In it, the mirror locations are such that the density of baselines increases roughly linearly with the separation. The idea is that the object spectrum for any system with unresolved bright components is close to flat. Therefore, one wants approximately equal coverage of the UV plane out to the diffraction limit to get the same SNR at each frequency. As longer baselines sweep a greater area when rotated, there needs to be more of them to give equal coverage.

A number of optimal Type III configurations were obtained for various numbers of subapertures and different subaperture sizes using the Monte Carlo method with more than 10, 000 trials each. The subapertures were constrained to lie at equal distances from the optical axis, so that they can be fabricated by replication. Each subaperture was divided in 10x10-cm elements and the moduli of the elementary baselines were binned in 10-cm intervals. The optimization criteria was to minimize the rms of the spread of the modulus distribution with respect to the ideal function. We have selected a configuration with six 60-cm-diameter mirrors as being a good compromise between the number and size of subapertures.

Figure 2 shows the three configurations described above together with their corresponding UV plane coverage and point spread function in the image plane. We are planning to conduct computer simulations and laboratory experiments to evaluate these configurations as a function of the type of object to be resolved and the point spread function deconvolution algorithm.

Optical Design

Interferometers used in optical astronomy are generally of the Michelson type. This design suffers from a lack of field⁴ and poor throughput especially in the UV due to the large number of relay mirrors required. Our proposed instrument is of the thinned aperture or Fizeau type (figure 3). This interferometer configuration uses a smaller number of reflecting surfaces and offers a sufficient field of view to permit guiding using offaxis "bright" stars.

The final numerical aperture of the system is determined by the necessity to match the angular resolution of the system to the detector's pixel size. Using the Nyquist criterion, the final numerical aperture of the system must be $F/D = 2p/\lambda$, where F is final focal length of the system, D the overall aperture diameter, p the pixel size and λ the operating wavelength. Table 1 gives the minimum numerical aperture of the system as a function of the wavelength for current typical pixel sizes.

Table I

Wavelength (μm)	Resolution (milli-arcsec)	Detector pixel size (μm)	F/ratio for optimal match
1.0	42	50	100
0.6	25	15	50
0.24	10	15	125
0.12	5	15	250

Since a fast primary surface is essential to minimize the overall length of the telescope, obtaining such slow beams directly would lead to an impractical Cassegrain magnification. This is exemplified by figure 4 which shows the influence of the Cassegrain numerical aperture and that of the primary surface on the major optical parameters of the system. The tradeoffs are complex and will require an indepth study, but for the purpose of our conceptual study an $f/1.2$ primary and $f/12$ Cassegrain appeared to be reasonable combination. Optical relays will be used for reimaging onto the three detectors (UV, visible, and near-IR) with the appropriate scale. These relays should be coated to minimize reflecting losses in each of the wavelength bands.

The Cassegrain combination will be of the Ritchey-Chretien design to produce a large enough field of view. A total field of at least 10 arcmin in diameter is required to give a good probability of finding a pitch-yaw guide star in the 14th magnitude range. We would expect roll control to be achieved using fixed head star trackers. As in the case of the science field, reimaging will be required to produce a proper scale.

Cophasing and coaligning system. In view of the very tight tolerances on the respective position of the optical elements and the focal plane and the lack of external shielding, one cannot

rely on the dimensional stability of the structure, either passively (with insulation), or actively (with structural heaters). An active system is required to "freeze" the image during the exposures.

Our proposed active optics systems is composed of actuators on the primary mirrors and the secondary mirror served to a laser metrology system controlling the internal optical path lengths. This metrology system, using a Dyson⁵ interferometer, is described schematically in figure 5. The active optics system is bootstrapped by observing a bright star in the focal plane and coaligning and cophasing each primary aperture in successive pairs. Each primary would be depointable to remove its contribution from the focal plane. This is desirable to allow for failures on orbit in any event. The metrology system is then activated to "lock-in" the optical pathlengths between the various optical elements and the focal plane.

In addition to serve to cophase the interferometer, the active optics system will also be integrated in the pointing control system of the spacecraft. The pointing system will be composed of two layers. A traditional spacecraft attitude control based on gyroscopes and star trackers will be used for slewing and coarse pointing. The fine pointing (guiding) will be done by using the active optics system to steer the optical beam based on the information supplied by a guide star in the field.

Spacecraft General Design and Orbit

As shown in figure 6, the supporting structure is composed of a central tower and six articulated arms. These arms are braced with telescopic members which extend for deployment and confer axial rigidity to the structure. Once open, the moments of inertia around the three axes are nearly equal, thus minimizing the attitude control requirements.

The entire interferometer assembly is protected from the sun by a sunshade located on the rear of the spacecraft. There are no side baffles. This leads to a considerable simplification of the spacecraft structure, but the price to pay is that the pointing has to be limited to about 45 degrees from the antisun direction. The solar arrays are attached to the sunshade to avoid the low frequency excitations that a steerable system would create.

The entire telescope structure and optics will be passively cooled by radiation against the sky to allow near IR observations. Preliminary calculations indicate that a temperature on the order of 100 K may be attainable.

As for the orbit, we are conducting an indepth study to determine which of the possible Earth orbits would be the most favorable for the proposed instrument. Factors such as thermal and mechanical disturbances, sky coverage, radiation level, observing efficiency, baffling, and communication are being considered. So far the main contenders appear to be the 6-pm sunsynchronous and geosynchronous orbits which offer significant advantages over low Earth orbit.

The overall mass of the spacecraft is estimated at 3 tons, which is compatible with the payload capacity to sunsynchronous or geosynchronous orbit of medium-sized launchers such as Ariane 4.

Conclusion

We have outlined here our approach to going beyond the resolution of HST. It seems to us that a space interferometer is eventually going to be a necessary next step. Even with a modest baseline the scientific drivers are enormous. The concept we are developing forms the basis for a cost effective first attempt in this direction.

References

1. Roddier, F., 1987. Redundant v.s. non-redundant beam recombination in aperture synthesis with coherent optical arrays, HOSA A(4)1396.
2. Reinheimer, T., 1988. Fleischmann, F., Grieger, F., Weigelt, G. 1988, Speckle masking with coherent arrays, Proc. ESO Conf. High-resolution imaging by interferometry, Garching, p.581.
3. Cornwell, T.J., 1988. A novel principle for optimization of the instantaneous Fourier plane coverage of interferometric arrays, IEEE Trans. Ant. Prop. 36(8):165.
4. Harvey, J.E., 1987. Performance characteristics of phased array and thinned aperture optical telescopes, Proc. SPIE 751:62.
5. Dyson, J. 1957. Common-path interferometer for testing purposes, JOSA 47:386.

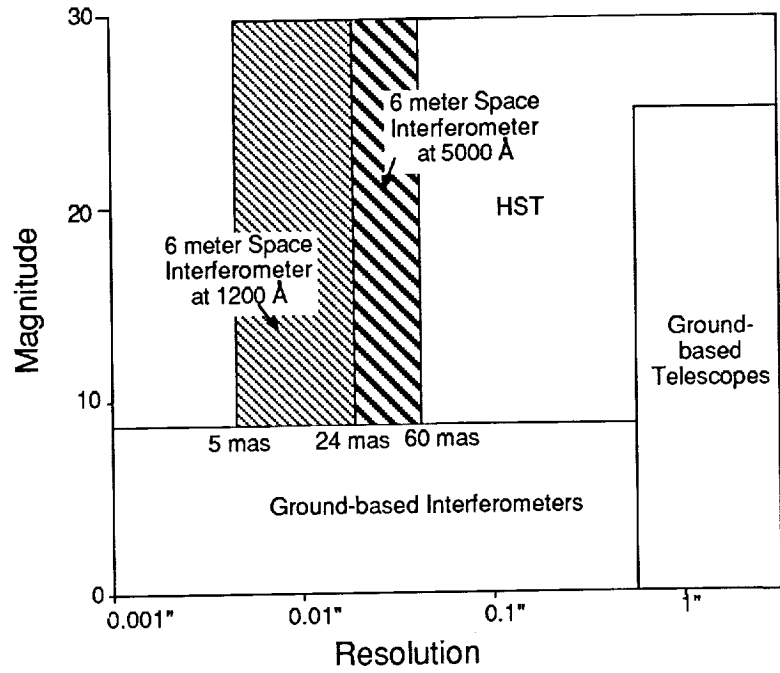

Figure 1: Domain of the proposed interferometer (hatched area) compared to that of existing or proposed instruments.

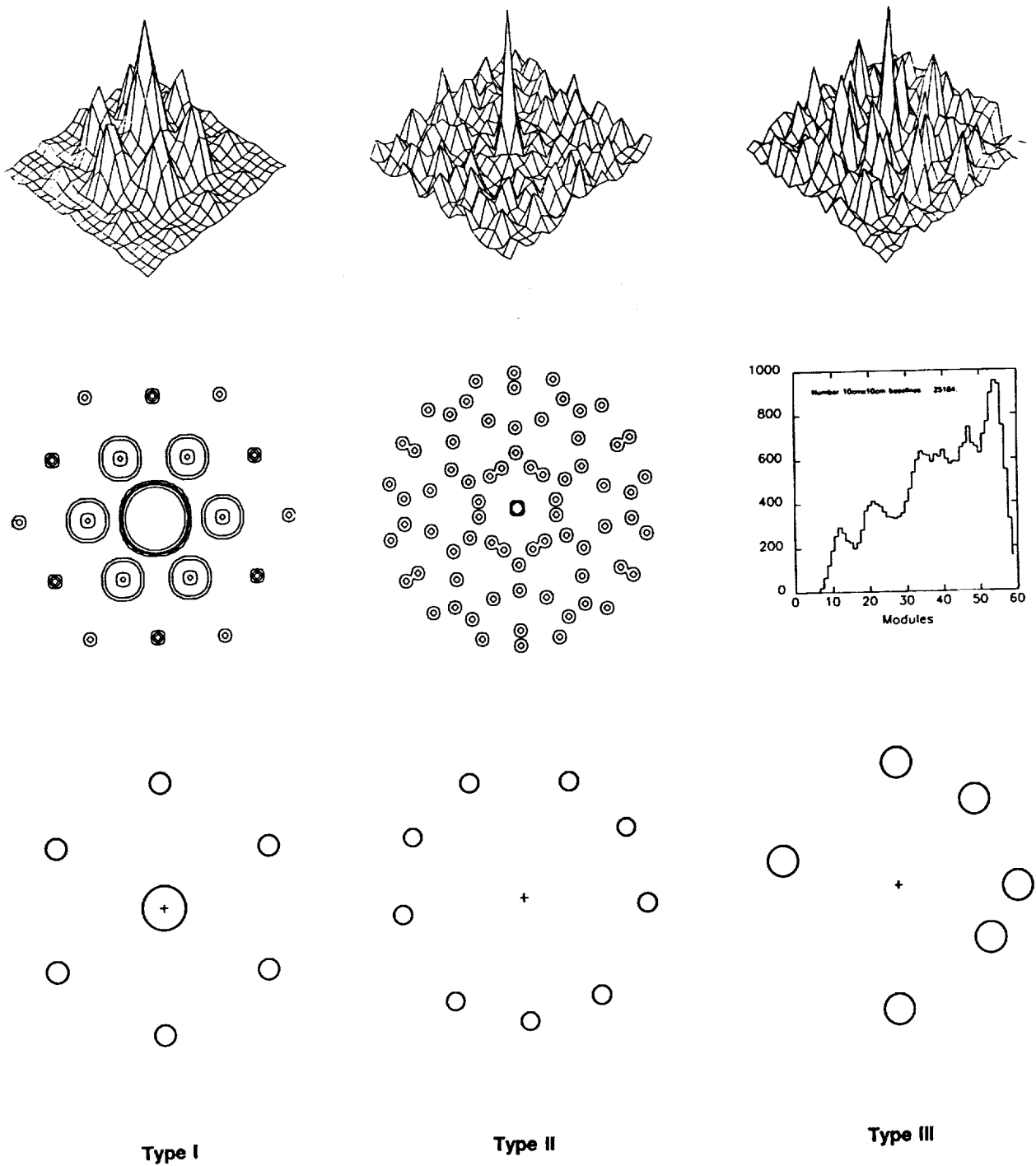

Figure 2: The three aperture configurations under study (bottom) shown with their UV plane coverage (middle) and the point spread function (top). For Type III which is rotated around its axis during observations, the histogram of the baseline modules is shown instead of the two-dimensional UV plane.

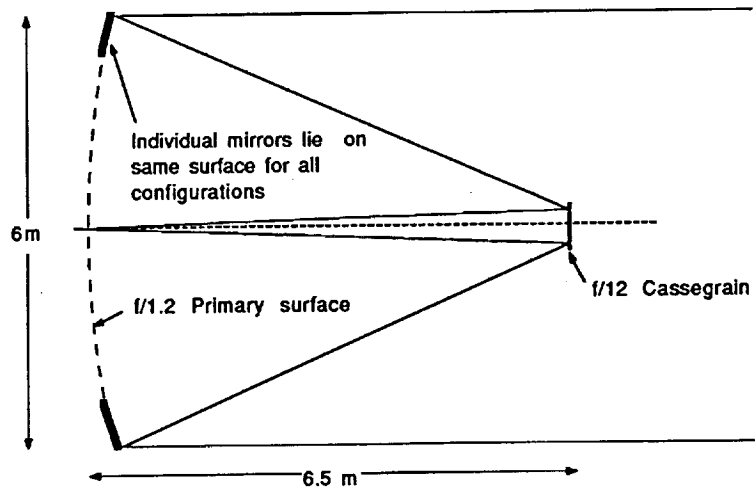

Figure 3: Schematic optical diagram of the proposed interferometer. The Fizeau configuration is preferred over the Michelson type because of its larger field and small number of reflecting surfaces.

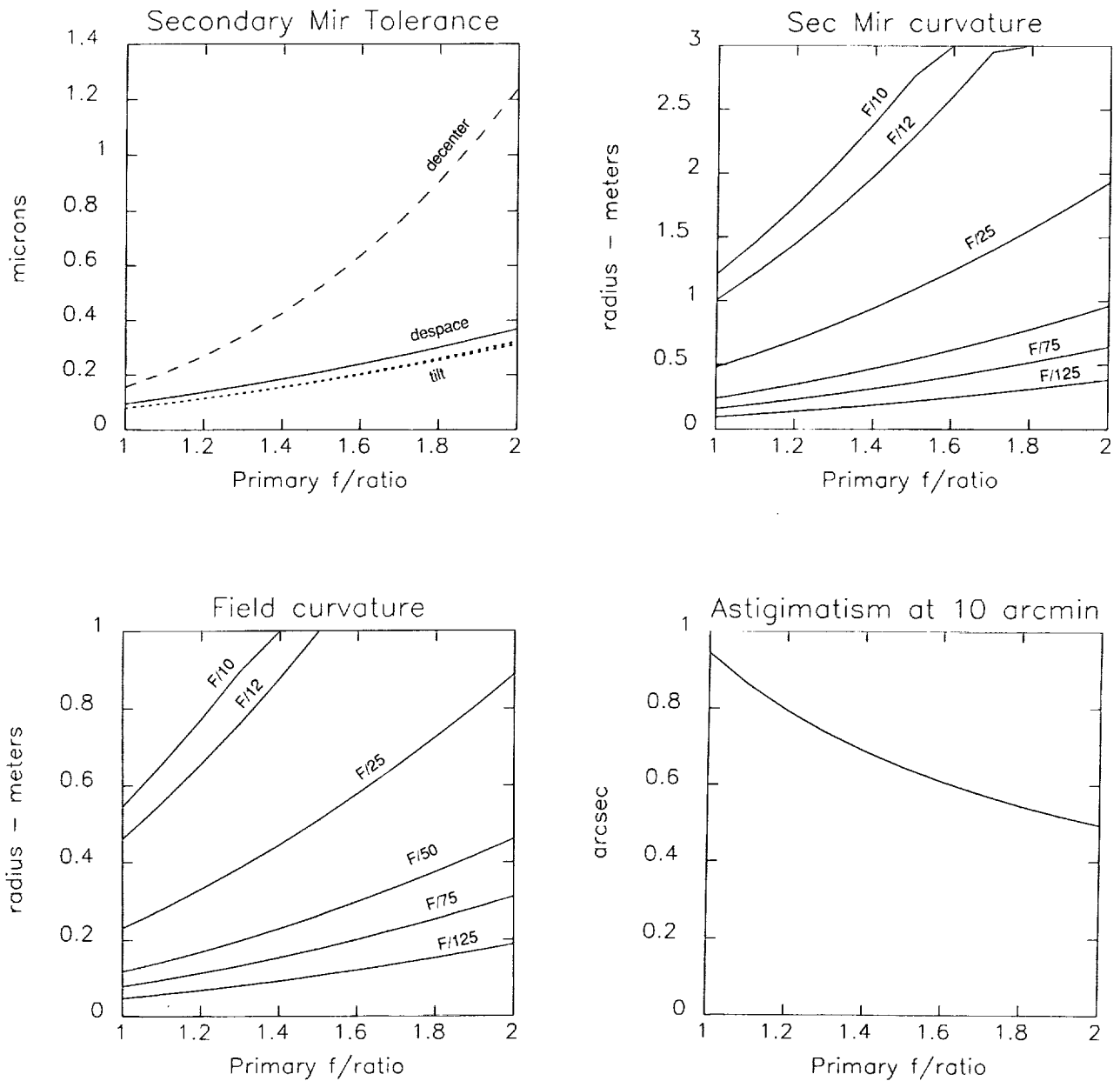

Figure 4: Effect of the primary mirror surface and final beam numerical aperture on the secondary mirror positioning tolerances, secondary mirror curvature, field curvature, and astigmatism. Only the secondary mirror curvature and field curvature are dependent on the final beam numerical aperture, the secondary mirror position tolerance and astigmatism are not, at least to the first order. All effects are shown for 1200Å and assuming a Ritchey-Chretien combination. The value for the secondary mirror tilt tolerance is given in displacement at the edge of the mirror.

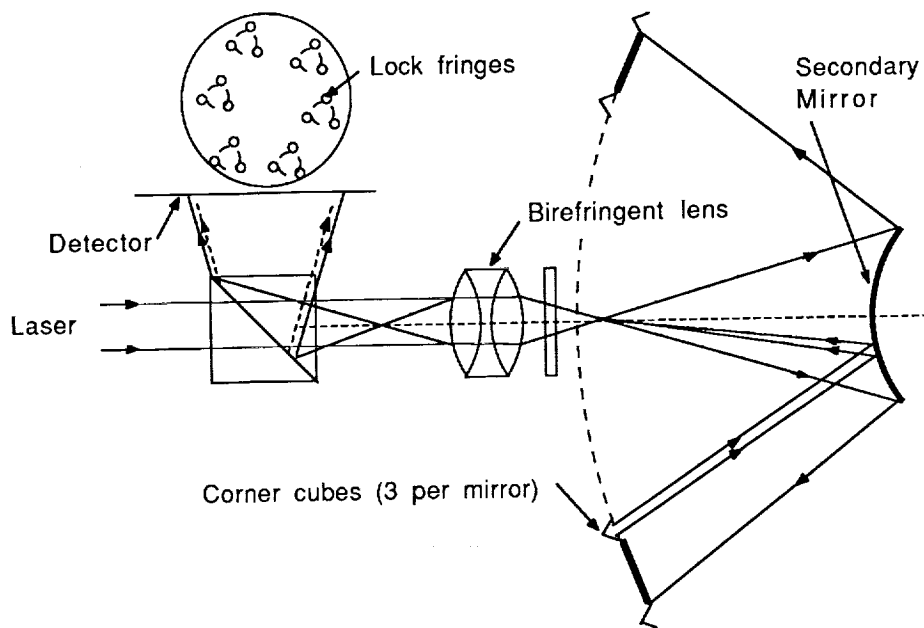

Figure 5: Coaligning and cophasing system. A Dyson interferometer setup is used to maintain the optical path lengths in the system using retroreflectors mounted at the periphery of the primary mirrors.

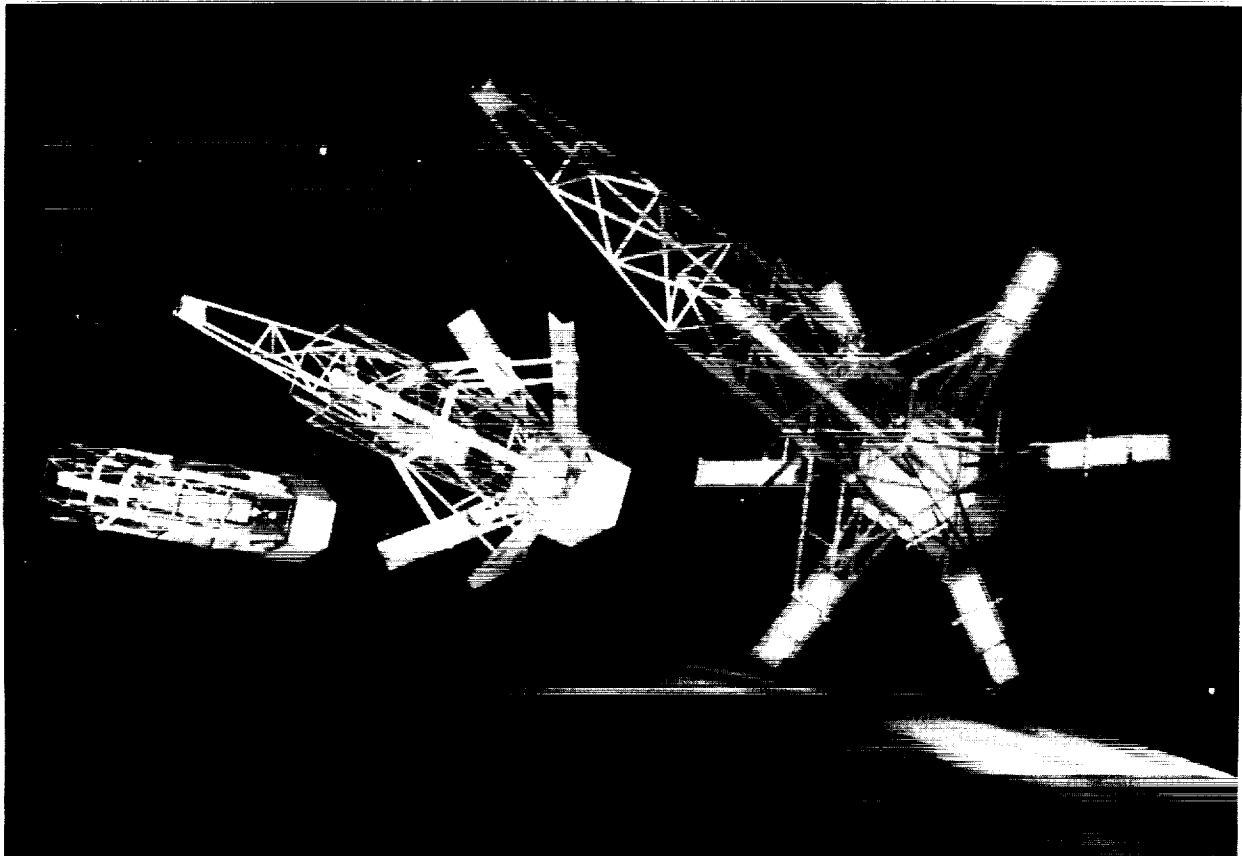

Figure 6: Artist's view of the proposed interferometer during deployment.

SUPPORT AND SERVICING REQUIREMENTS FOR LARGE
OBSERVATORIES IN SPACE

Thomas E. Styczynski

Astronautics Division
Lockheed Missiles & Space Company
Sunnyvale, CA

Abstract

The concept of lunar optical and IR observatories is a natural step in the total utilization of the space environment for the benefit of science. Among the challenges associated with this remote observatory concept is the requirement for the support and servicing of the facility.

This presentation will draw on the experience of the Hubble Space Telescope (HST) program on-orbit maintenance design requirements plus the Lockheed on-orbit servicing and assembly activity to develop requirements for the maintenance and construction of a lunar observatory.

Introduction

Often when an important space science program is initiated, the focus of that program is limited to the resolution of the hardware and technology issues of that program alone. What is often missing is an understanding of the relationship of that program to an operational infrastructure. This operational infrastructure includes the launch systems, ground facilities, space operations nodes, and mission control systems, ground facilities, space operations nodes, and mission control systems (figure 1).

The growing cost of program development is starting a trend toward long-term operation of space assets. Now these assets are faced with support and servicing issues associated with these extended life goals.

The lunar basing of large observatories introduces unique requirements which must be addressed early in the system concept development and design. This paper will address lunar base

support and servicing issues and design requirements and concepts, and recommend areas for near- and far-term action.

Lunar Base Support and Servicing Issues

The concept of lunar basing of assets is faced with some basic issues that affect the design requirements. These issues include human presence requirements; access limitations; site selection and preparation; facility verification requirements; site assembly; basic facility requirements; and precision scheduling.

The human element added to any remote facility requires that the design support humans as well as the experiment. This extends from the construction phase where tools and support equipment is impacted to the operations phase where on-site science evaluations must be traded with remote and delayed observations.

Relying on automation and robotics must be considered as an option. Keeping the systems simple and reliable (i.e., limiting the machine degrees of freedom) is a goal that can only be reached by integrating the design and operational phases. It has been determined that designing for automated operation simplifies the task for human operation whereas the opposite is not necessarily true.

Access to the facility affects the system reliability design requirements. Serviceable space systems do not relax the reliability requirements or the redundancy in design because the supporting infrastructure cannot guarantee rapid response to a failure. In the case of a remote facility the storage of spares and test and verification equipment onsite impacts the facility size and operations.

The site selection and preparation has some design challenges. The construction of the facility must evaluate the utilization of natural resources to minimize the transportation of materials to the site. Selecting a site that is easy to prepare, contains useful construction materials, and meets the science requirements may require an extensive lunar survey.

Simplifying hardware integration is a goal of any large program. For a space-based facility this may mean preflight assembly and checkout; disassembly for launch; and reassembly and verification on site. These considerations should include evaluation of the

impacts system partitioning and modularity present to the basic design. There is also a tradeoff of built-in test requirements versus using support equipment for test and verification.

Construction sites are easily cluttered with packaging materials and equipment used in a particular phase of assembly. Time spent in handling these materials is time lost in actual assembly. Minimizing the tools, hardware, equipment, and time necessary for remote site assembly is important to reducing these logistics support requirements.

Lunar observatory facility requirements are not unlike Earth-based requirements. Cleanliness, reliable power, system alignment, environmental protection, and operations are all basic requirements. The biggest challenge will be in the protection of the environment. The lack of atmosphere, necessary for undistorted celestial observation, is a primary attraction of the lunar facility concept. The design must assure that this is not impacted by the construction and operation of the facility. Conversely, the facility must consider the hardening requirements for protection from radiation and potential physical impact of meteors.

Consider the impact of the loss of a facility element during the construction phase. The facility must survive while this element is replaced. Precision scheduling will assure that alternate assembly paths are available to minimize the schedule impacts.

Support and Servicing Design Requirements

Traditionally, space programs reflect a point design. This point design is governed by schedule and technology risks associated with accomplishing a mission in a cost-effective manner but on a mission-by-mission basis. Incorporating support and servicing requirements into any system greatly increases the flexibility of that system to respond to technology enhancements and to accommodate additional science requirements. The HST, for example, is launched with science instruments designed to meet the basic mission requirements. This program has addressed the potential for science changes by incorporating features in the design to accommodate an IR instrument in place of an existing optical instrument.

Another plus to this approach is that the system is no longer constrained by hardware availability. Replacements can be accomplished at various levels of hardware integration (i.e., system, subsystem, box, board, component) depending on where the interface is controlled.

A system with a long operational life will have periodic maintenance requirements. These may include the replenishment of consumables, like purging gases and cryogenes, or the replacement of items that have limited life, like bearings and batteries. A servicing design can increase facility availability by responding to problems that would require an operational workaround, reduction in mission capability, or a total system loss.

Design considerations for support and servicing of assets in space require a change to basic design habits. Space systems are often designed for the operational mission alone. This leads to operations panics when a system is sensed to have failed or degraded to a questionable operational level. A servicing design must look at subsystem partitioning on the basis of potential replacement. This may include packaging of low-reliability equipment into easily accessible packages or separating redundancy into separate boxes. The goal is to eliminate the impact of the system loss until an exchange can be accomplished.

The power bus designs must allow for localized power shutoff and potential power changes (i.e., increases or reductions). Data system bus designs must be compatible with system upgrades that might impact data rate increases or changes in system languages.

The systems will require more built-in test equipment and sensing. This equipment will focus on the failure data to assure the trend is not carried in the replacement unit and to minimize the integration time.

In each of these cases modularity and standardization will play a significant role in reducing requirements spares, interface control, and training. This is of particular interest to the science instruments where alignment repeatability may dictate a maximum of $\pm 0.076\text{mm}$ (± 0.003 in) position shift in every axis. This type of alignment repeatability is achievable in current orbital replacement unit (ORU) designs. Keeping the interfaces simple and standardized will greatly reduce the requirement for support equipment: tools, assembly fixtures, and test equipment. An example of the type of interfaces is shown in figure 2. Here a concept ORU is designed as a module with a single mechanical attachment interface. The design provides for module alignment and ganged connector installation. The simplicity of the interface allows for both robotic and manned installation using an adaptable power tool. Hardware concepts of this type were developed and tested as part of the Space Assembly, Maintenance, Servicing (SAMS) study completed by Lockheed in August 1987.

Conclusions and Recommendations

Current space asset supportability and servicing concepts have direct applicability to the concepts of lunar observatories. It is essential that these servicing concepts be incorporated into the early design concepts to minimize future impacts.

It is highly recommended that the supporters of lunar observatories participate in existing and future servicing workshops and studies.

Reference

1. Styczynski, T., no date available. Space Assembly, Maintenance and Servicing Study: Design Concept Handbook. Lockheed Missiles and Space Company, Sunnyvale, CA.

N 9 3 - 1 3 5 9 0

SCIENCE OBJECTIVES FOR GROUND- AND SPACE-BASED
OPTICAL/IR INTERFEROMETRY

Stephen T. Ridgway

National Optical Astronomy Observatories*

P.O. Box 26732

Tucson, AZ 85726

Abstract

Ground-based interferometry will make spectacular strides in the next decades. However, it will always be limited by the turbulence of the terrestrial atmosphere. Some of the most exciting and subtle problems may only be addressed from a stable platform above the atmosphere. The lunar surface offers such a platform, nearly ideal in many respects. Once built, such a telescope array will not only resolve key fundamental problems, but will revolutionize virtually every topic in observational astronomy. Estimates of the possible performance of lunar and ground-based interferometers of the 21st century shows that the lunar interferometer reaches the faintest sources of all wavelengths, but has the most significant advantage in the infrared.

Introduction

For decades astronomers have viewed optical interferometry as the esoteric province of a coterie of off-beat experimentalists, bent mostly on the pursuit of the elusive stellar angular diameter.

But recently, spectacular success in the radio community and rapid technical advances in electro-optics, have stimulated a growing community of scientists committed to the systematic application of interferometry to optical astronomy. As a result of the growing excitement in that community, and real evidence of progress, more than a dozen major facilities for optical/IR interferometry are now in progress, including the largest ground-based telescope project of all time, the VLT.

*National Optical Astronomy Observatories, operated by the Association of Universities for Research in Astronomy, Inc., under contract to the National Science Foundation.

We may expect that the still accumulating momentum of these efforts will eventually overcome the cultural obstacle of inadequate funding. The limitations of the terrestrial atmosphere, however, may prove intractable. Unfortunately, some important problems may remain beyond the reach of ground-based interferometry. For these problems, it will be necessary to move to space.

Science Drivers

Increased spatial resolution will further our understanding of virtually any astronomical object to which it is applied. But when the telescope under consideration represents a very large investment, many of the day-to-day issues in astronomy may appear anemic indeed. For example, while I am very interested in the subject of mass loss from cool stars, I would not suggest it as a strong motivation for a billion-dollar investment. To justify a large increment in funding, astronomers historically turn to the issues with deepest philosophical significance - the origin and fate of the cosmos, and man's place in it.

The following specific observational objectives have been selected from contemporary research as examples of the use of optical interferometry for research into the grandest questions. Of course, the list is not in any sense comprehensive. However, it does provide a starting point, and defines an interesting set of performance specifications.

Primeval Galaxies and Galaxy Formation

It is probably safe to assume that the search for primeval galaxies will eventually succeed. Flux distributions and spectra will reveal some information about the stellar and nebular content of these galaxies. Spatial and spatio-spectral information would be invaluable. Searches conducted to date suggest that these objects may have magnitudes $V > 25$ and $K > 20$. The angular diameters are predicted to be ≈ 1 , so resolution of the disk will be possible with a moderate telescope aperture. Interferometry will be useful in obtaining direct measurements of the size of giant star-forming regions, of nuclear accretion disks, etc. Amazingly enough, such measures are not out of the question.

Quasars and the Mass Distribution of the Universe

The discovery of gravitational lensing of quasars by intervening material revealed a new tool for observational cosmology. The currently observed structure in the lensed images, on the order of an arcsec, is apparently induced by galaxy scale masses. Smaller masses are predicted to produce smaller structures. For example, a hypothetical unobserved population of 1 solar mass objects would be revealed by image splitting of order 1 microarcsec (Rees 1981). While the probability of such a population may be low, the alternative methods for direct detection are few. A good selection of quasars may be reached with a limiting magnitude of ≈ 22 . Rix and Hogan (1988) have already reported a correlation of apparent quasar brightness with respect to proximity of foreground galaxies to the line-of-sight, suggestive that microlensing is in fact occurring, although this interpretation is not unique (Narayan 1989).

The Structure of Active Galactic Nuclei

The longstanding problem of energy generation in Active Galactic Nuclei (AGN) may be subject to direct study with high spatial and moderate spectral resolution. Ulrich (1988) has described the possible observational objectives available to interferometric study. At 10 milliarcsec, it is possible to study the distribution of ionized gas (the narrow line region). With resolution approaching 100 microarcsec, it should be possible to resolve the broad line region and a possible accretion disk. With microarcsec resolution, it should be possible to resolve the hypothetical UV continuum photosphere. Relatively bright AGNs are known, but to have a reasonable set with minimal extinction and appropriate viewing angles, it may be necessary to reach $V=20$.

The Scale of the Universe

Precision astrometry will have profound implications for many areas of astronomy. With microarcsec precision, the distances to the nearest galaxies could be determined directly with a precision of 1 percent (Reasenberg et al. 1988). Measurement of these distances would confirm and secure basic stepping-stones to the cosmological distance scale. The brightest stars in M31 have magnitudes $V \leq 17$.

Galactic Structure

Astrometry, again, is the key to a more comprehensive study of structure and dynamics of the galaxy and its nearest neighbors. Microarcsec precision will permit 3-D mapping of our entire galaxy (in the infrared, to penetrate extinction in the disk) and the Magellanic clouds. Such information will greatly strengthen our understanding of the current state of the galaxy and its evolution. Typical giant type stars (K0III) in the Magellanic clouds have magnitudes $V \approx 19$ or $K \approx 16.7$.

Planet Formation

An observational probe into the origin of our solar system may be available from observation of young stars in star-forming regions. At typical distances of such regions (500 pc) a solar type star will have an apparent magnitude of 13. The radius of the Earth's orbit at the same distance will subtend an angle of 2 milliarcsec.

Seeing limited and speckle measurements of T Tauri stars have in a few cases revealed possible preplanetary material with possible disk-like structure, and angular extent of order 1 arcsec. Planetary formation may occur within such disks, and although direct observation of the formation process may be obscured, direct detection of the radial distribution of abundances in the preplanetary disk may be possible.

The Nearest Stars

The nearest stars are interesting primarily for their proximity. To the astronomer this promises the opportunity for detailed study. To the dreamer, they are stars that our descendants might hope to visit in a lifetime with Earth-scale technology and without violating physical laws. The nearest 100 stars have magnitudes $V \leq 13$, and are at distances up to approximately 6.5 pc (Allen 1973). The apparent angular diameter of the sun at 5 pc would be 1 milliarcsec. Direct observation of the sunspot cycle might require spatial resolution of 10 microarcsec.

Summary of Instrumental Requirements

Table 1 collects the estimates of required sensitivity and spatial resolution for the scientific objectives described above. Of course it is understood that in many cases the requirements are merely order-of-magnitude estimates.

Table I. Instrument Requirements for Science Objectives

Program	V mag	K mag	Resolution (microarcsec)	Precision (microarcsec)
Primeval galaxies	>25	>20	?	
Quasar lensing	20		1	
Active Galactic Nuclei	20	18	1-100	
Distance scale	17			1
Galactic structure	19	17		1
Cosmogony	13	15	1000	
Nearest stars	13	13	10	

The range of the requirements is clearly quite diverse, and with the inclusion of a wider range of scientific objectives (Ridgway 1989) would be more diverse still. It appears that except for primeval galaxies, still a speculative subject, the magnitude limit does not appear to be extreme. However, when details of image complexity and dynamic range are folded into the estimates, the effective sensitivity required will in some cases be much fainter than the numbers tabulated here.

The principal regimes of spatial resolution are of order 1 milliarcsec and of order 1 microarcsec. The optical baselines required to reach these regimes are shown in table 2. Obviously, microarcsec resolution is more likely to be achieved at short wavelengths.

Table 2. Baseline Required for Angular Resolution

Wavelength (microns)	1 milliarcsec resolution	1 microarcsec resolution
0.55	0.11 km	11. km
2.2	0.45	45.
10.0	2.0	200.

Now let us review the potential of interferometry from the ground and from low Earth orbit, to see what performance might be accomplished by aggressive development programs without the cost of a lunar-based telescope.

The Promise of Ground-Based and Near-Earth-Orbit Interferometry

Ground-Based Interferometry. The Earth probably offers at least a few adequate observing sites with the required features for a large optical interferometer: good seeing, large baseline potential, stable subsoil, and seismic quiescence. The essential problem in ground-based interferometry is overcoming the wavefront perturbations introduced by the atmosphere, and the vibrations in the instrument provoked by wind. Since we are looking into the future, we will adopt a telescope configuration which might be appropriate for the early years of the next century. We assume that our interferometer consists of two or more 8-m telescopes, located on a site with seeing of 1 arcsec at 5000Å.

For bright sources, the source itself will provide sufficient information to measure and compensate the atmospheric errors. Roddier and Lena (1984 a,b) give relatively conservative estimates for the limiting magnitudes for source referenced phase stabilization, and find, e.g., $V \approx 13$, $K \approx 14$, and $N \approx 5$.

If the technique of an artificial reference is incorporated, then each telescope may be equipped with a laser reference star system. The artificial star will be generated in the ionosphere and used to control an adaptive optical element which corrects the wavefront distortions, effectively increasing the r_0 parameter to a value comparable to the telescope pupil diameter. Thus each 8-m aperture will be fully phase coherent.

However, the laser reference star system provides no help with the relative phasing of separate telescopes. The relative phase of the two telescopes will still drift with a time constant characteristic of the atmospheric turbulence or of the instrument vibrations. The cophasing of independent telescopes still requires reference to a source in the field. An estimate of the characteristic time for relative phase drift can be obtained from the ratio of the phased beam diameter to the wind velocity in the relevant part of the atmosphere. For an 8-m aperture and 4 m/ sec wind, the phasing will likely drift in times of order 2 sec. To preserve phasing there must be a source in the field bright enough to obtain reasonable signal-to-noise ratio (SNR) in 2 sec.

Optimistic estimates for the limiting magnitudes with an 8-m ground-based (BG) telescope, using an artificial reference, are shown in table 3.

Owing to the assumed large aperture of the telescope, the ground-based interferometer will very quickly obtain high SNR on any source bright enough for cophasing of the telescopes.

For sources too faint for cophasing, the ground-based telescope must be used in an absolute mode, whereby the coherence condition between the telescopes is obtained by reference to the instrument. With this method it will only be possible to gain a few magnitudes in sensitivity, and at the price of long observation times. Furthermore, the method of absolute interferometry may not be useful with large telescopes, as it may not be possible to obtain the internal metrology required for a large and necessarily flexible structure. Thus the optimistic sensitivity estimate for the artificially-referenced 8-m telescope may represent an ultimate performance limit for ground-based interferometry.

It is difficult to estimate the maximum baselines which may be obtainable on the ground. Baselines of order 100 m will clearly be no problem. The Sidney University Stellar Interferometer, currently under construction, has baselines to 640 m. Multikilometer baselines appear possible, although the practical problems accrue steadily. For example, it may not be possible to find a site which offers a multikilometer baseline, adequate UV plane coverage, good seeing, and acceptable meteorology.

Near-Earth Orbit

Installing an interferometer in space has obvious advantages in escaping the effects of the atmosphere. The potential improved performance of an instrument in space may be described, following Greenaway (1987): Greenaway, A.H. 1987 in ESA Workshop on Optical Interferometer in Space, ed.n. Longdon and V. David, (ESA, Noordwijk), p.5.

$$\frac{SNR(space)}{SNR(ground)} \approx \left(\frac{d_s}{d_g}\right)^n \left(\frac{t_s}{t_g}\right)^{n/2}$$

where d is the area of the coherent aperture and t the coherence time on ground and in space. The coefficient n will be typically 1 or 2, depending on the limiting noise source. As we have seen, with the use of artificial reference stars, the ratio of coherent aperture areas may greatly favor the

ground (8-m telescopes). This ground-based advantage may be most easily realized in the near infrared, 1 to 3 μm , where the atmospheric turbulence is low and the thermal background is still modest. Potentially, the factor t favors space, where no atmospheric effects enter. Is this gain actually realized?

While moving to Earth orbit eliminates the problems of the atmosphere, it also deprives the experiment of a massive, rigid foundation that can absorb vibrations with minimal deformation. The use of self-referencing to phase an instrument is conceptually similar in space to on the ground. In space, the limiting magnitude may be brighter owing to the smaller coherent aperture. However, the isoplanatic region may be very large because of the absence of atmosphere. Instrument deformations induced by gravity gradients should be slow, but may have large amplitude for large structures, hence are another hindrance to large baselines in near-Earth orbit. Therefore, baselines exceeding 10-100 m would appear questionable for near-Earth orbit. It is probable that in near-Earth orbit the most interesting interferometric configurations will employ relatively short baselines, permitting excellent structural rigidity and control.

A number of extensive studies for orbiting interferometers have been completed, and are a good basis for projecting the probable performance of such a system. A type of instrument which appears very promising is a compact system, such as POINTS (Precision Optical INTERferometry in Space; Reasenberg et al. 1988), and the extension of the concept to somewhat larger configurations and larger numbers of telescopes. POINTS employs a two-telescope interferometer (actually two such at right angles) with 25-cm apertures, to reach a projected limiting magnitude of $V=17$. This limit compares favorably to the limit estimated above for a ground-based 8 m, probably because of the relative long coherent integration times expected with POINTS. With a small (2-m) baseline, POINTS achieves microarcsec precision in astrometry by careful control of errors rather than large optical baseline. This appears to be an excellent strategy for near-Earth orbit.

Reaching much fainter limiting magnitudes would require larger telescopes or longer integration times. This would aggravate the structural and control problems. Thus, there may be natural limits to the sensitivity of near-Earth orbit interferometric telescopes.

The tradeoffs between high Earth orbit and the lunar surface deserve careful study, and the preferred location may depend on the assumptions concerning transport cost and accessibility.

A Lunar Interferometric Array

Concepts for a lunar optical/IR interferometric array are discussed in detail in the other contributions in this volume. Here I will just make some predictions of the sensitivity of a lunar array.

Compared to ground and near-Earth orbit instruments, the lunar-based array is likely to gain primarily in the allowed coherent integration time. Times of an hour appear reasonable, and that is the value used here. In fact, guaranteeing a large value of this order appears to be the critical technical issue for the scientific success of the lunar-based array, hence deserves the most careful scrutiny.

Limiting Sensitivity

With a coherent integration time of an hour, a lunar telescope will naturally reach impressive limiting magnitudes. Estimates for the magnitude limits for a 1.5-m lunar-based telescope (LB), are shown in table 3 for one set of assumptions.

Table 3 Limiting Magnitudes for Cophasing of Telescopes*

Wavelength (microns)	0.55	2.2	3.5	5	10
8.0 m BG - Artificial reference	28	21	17	14	10
1.5 m LB - Source reference	29	25	24	19	13

*Efficiency 0.1, integration time 3600 sec, S/N=5, point source reference (visibility = 1.0); additional parameters for the IR: warm emissivity 0.20, cold efficiency 0.13, telescope temperature 150K; detector read noise 30 e⁻, detector dark current 1 e⁻/sec, noise from four pixels contributes to every fringe detection. It is assumed that all the photons in a bandpass $\delta\lambda/\Delta\lambda=0.5$ are utilized.

The relative performance of the telescopes depends on the limiting noise source. In the visible, the limit is source photon noise for short integrations, and sky background for longer integrations. In the near-infrared the detector noise is the limit, and in the longer wavelengths the telescope emission.

The limits in table 3 are impressive. However, they are also misleading. For ground-based observations with a large telescope, the major problem was phase stabilization for any object for which that could be maintained in SNR would accumulate to a high value within minutes. In the lunar case, with an assumed small telescope aperture, phase stabilization can be achieved for faint sources, but only with long integrations. Thus table 3 is useful for estimating the limiting magnitudes for very high priority faint sources. As the faint limit, for the lunar-based case, low signal would probably preclude mapping, and only estimation of typical source size and other basic parameters might be possible.

A more realistic limiting sensitivity for image reconstruction would be to require a SNR of 100 (or even much higher) in 1 hour. These limits will be found in table 4. The values for the ground-based telescopes are simply copied from table 3 because the faint limit in that case is set by the limitations for phase stabilization.

Table 4. Sensitivity Limits for SNR = 100 in 1 Hour

Wavelength (microns)	0.55	2.2	3.5	5	10
8.0 m BG - Artificial reference	28	21	17	14	10
1.5 m LB - Source reference	26	22	21	16	9

Note that the values tabulated are for a broad spectral band ($R=2$) and for a single baseline, appropriate for an object with approximately one "pixel." Study of a source with N pixels will require typically N baselines, and total integration time increased by N^n , where n will depend on the beam combination strategy and the limiting noise, but typical values in practice will be around $n=1$. Assuming that we can always achieve $n=1$, then for a source at the limiting sensitivity a total observation time of order 100 hours will be required for a source with 100 image pixels.

On the positive side, fringe detection may be carried out (in either the pupil plane or the image plane) to preserve the spectral information at moderate resolution while stabilizing the fringes with the broadband flux, so some spectral resolution is implied at even the faint source limit.

The table of limiting sensitivities shows the well known strong dependence of IR sensitivity on telescope temperature. The dependence on temperature is so much stronger than the

dependence on telescope size that a cooled telescope will almost always win. At the temperature selected for this discussion, $T=150\text{K}$, the background on the blue side of the Planck distribution is greatly reduced, giving greatly improved performance at $2\text{-}5\ \mu\text{m}$. To extend this improvement to $10\ \mu\text{m}$ would require a telescope temperature of about 65K , hence probably a specialized, rather than general-purpose, instrument.

Intercomparison of the Ground and Lunar Interferometers

In this comparison, both telescopes perform quite well (even spectacularly). The space instrument has a clear sensitivity advantage at the faint source limit. This advantage is largest in the infrared. However, this conclusion is obviously dependent on the numerous parameters — especially the coherent integration time on the lunar surface and the telescope temperature. Assumed diameters of interferometric telescopes on the ground and the Moon may be overly optimistic, and adaptive phasing of ground-based telescopes may not work as assumed.

A major shortcoming of this simple comparison of photon rates is the issue of the dynamic range achievable through the terrestrial atmosphere. It seems to me possible that correcting the atmospheric corrugations on a scale of r_0 may never suffice to reach really high quality imagery, even with closure techniques. But this will only be known as a result of trying.

It is certain that the first major step toward a lunar-based interferometer with many telescopes will be a ground-based interferometer with a few telescopes.

Conclusions

A lunar-based telescope has obvious advantages in the spectral ranges that are not available from the ground, and this should be an important consideration in developing a lunar observatory.

A general-purpose array will not satisfy both short wavelength and thermal IR requirements, so a separate thermal IR array might be considered.

Precision astrometry probably does not require either the lunar surface or the very large baselines available on the Moon.

A lunar-based interferometer will be competitive in its ultimate sensitivity limit with large ground-based telescopes. In the baseline model discussed here, the lunar-based interferometer will be capable of studying sources 1 to 7 magnitudes fainter in the region 0.3 to 10 μm . For sources bright enough to study from the ground, high SNR may (formally) be achieved more quickly from the ground than from the Moon. However, the realizability of this ground-based performance may be difficult or impossible to obtain in practice.

The lunar interferometer will excel in precision imaging of relatively bright sources (e. g., $V = 26$ and $K \approx 25$). This covers all of the scientific problems discussed above and summarized in table 1. It will also have superb limiting sensitivity, applicable to mapping of sources so faint their existence is not yet even suspected.

References

1. Allen, C.W. 1973. *Astrophysical Quantities*, Athlone press.
2. Greenaway, A.H. 1987. in ESA Workshop on Optical Interferometry in Space, ed. Longdon, N. and David, V. European Space Agency, Noordwijk, p.5.
3. Narayan, R. 1989. *Astrophys. J. Lett.* (in press).
4. Reasenberg, R.D. et al. 1988. *Astronomical J.* 96:1731.
5. Rees, M.J. 1981. in *Scientific Importance of High Angular Resolution at Infrared and Optical Wavelengths*, ed. Ulrich, M.H., Kjaer, K. (ESO, Garching): 423.
6. Ridgway, S.T. 1988. in *Diffraction Limited Imaging with Very Large Telescopes R*, ed. D. Alloin (in press).
7. Rix, H.-R.; Hogan, C.J. 1988. *Astrophys. J.* 332:108.
8. Ulrich, M.H. 1988. in *High-Resolution Imaging by Interferometry*, ed. Merkle, F. (ESO, Garching): 33.

PART IV

LUNAR INTERFEROMETRIC ARRAYS

Politics, history, philosophy, geology, and technology are all part of the papers in Part IV that describe various aspects of constructing LOUISA on the lunar surface. These papers, derived from talks presented at the workshop, provide the foundation upon which the working groups were able to build a straw-man design for LOUISA.

C.B. Pilcher presented a very informative and entertaining after-dinner talk at the workshop on political forces that have driven space exploration in the past and may strongly influence a decision to build a lunar base; a paper derived from this talk leads off this section. N. Woolf waxes philosophical in discussing basic questions concerning human goals, the space program, and special science issues for a lunar optical interferometer. S.W. Johnson follows with an interesting review of past design studies of lunar-based astronomical telescopes, providing an important historical perspective. G.J. Taylor describes the lunar environment in detail with particular emphasis on both the advantages and concerns regarding the Moon's geologic features that will influence the operation of LOUISA. Johnson *et al.* then describes possible lunar environmental effects on an optical interferometer. B.F. Burke reviews and updates his original pioneering proposal for an optical VLA on the Moon including a discussion of the sensitivity, array configuration, optics, and costs; in an appendix, Burke also describes the limits on heterodyne receivers for optical interferometers. S.W. Johnson and J.P. Wetzel end Part IV with a discussion of required technologies for LOUISA.

TELESCOPES ON THE MOON OR PIE IN THE SKY?

Carl B. Pilcher
Director for Science (Acting)*
Office of Exploration
NASA Headquarters
Washington, DC 20546

[The following is a revised version of after-dinner remarks presented to the Workshop on Optical Interferometry on the Moon, Albuquerque, New Mexico, February 9, 1989.]

The title of this talk poses a question of realism. Does it make sense to believe that there will one day be an interferometric array of telescopes on the Moon, or is it just pie in the sky? The question is really one of national commitment to a lunar base, since it is not likely that a scientific undertaking of this magnitude would occur in the absence of permanent human presence on the Moon.

One can argue that of course there will be a permanently occupied lunar base someday, but that sidesteps the key question of what circumstances would lead a nation, the United States in particular, to make the major commitment of resources that a lunar base would require. Fortunately, there is a precedent: the Apollo Program. At its peak it commanded more than 4 percent of the federal budget, a proportion four times that of NASA's share today. Understanding the factors that led to the Apollo commitment may help us understand why the nation might make a similar commitment to return humans permanently to the Moon.

There has been much written about the Apollo decision, but I will draw here principally on Walter McDougall's account in "...the Heavens and the Earth," for which McDougall won the 1986 Pulitzer prize for history. Three events encapsulate the rationale for Apollo. The first was the launch of Sputnik in 1957. Eleven years earlier the RAND Corporation had predicted that satellites would become one of the most potent scientific tools of the twentieth century, and that the orbiting of a satellite by the United States "would inflame the imagination of mankind and would probably produce repercussions in the world comparable to the explosion of the atomic bomb."

*Dr. Pilcher is currently Chief, Advanced Studies Branch of the Solar System Exploration Division, Office of Space Science and Applications, NASA Headquarters.

In displaying this remarkable degree of foresight, RAND failed to anticipate one thing: that the Soviets might beat us to it! The launch of Sputnik caused Americans to question the basic assumptions on which their security and prosperity were based. American defense at the time was based on Eisenhower's "New Look," a policy under which nuclear weapons were considered to be as available for use in time of war as other munitions. Suddenly, with the launch of Sputnik, this policy was revealed to be hollow. The Soviet now had the ability, or so it seemed, to lob H-bombs over the U.S. at will! How could the U.S. continue to rely on bomber-based nuclear retaliation to deter a Soviet attack? In fact, the U.S. was well ahead in guidance technology, warhead design, and solid-fuel technology. We were slightly behind only in the development of ICBMs themselves. But that didn't lessen the public outcry.

Perhaps the most important aspect of Sputnik was the implicit political challenge that it posed. It not only undermined the assumptions on which western defense was based, it undermined the very values of western society. Here was the Soviet Union, an agrarian society just 40 years earlier, challenging the U.S. with a demonstration of technological and military might. If 40 years of Communism could so transform one nation, what could it do for others?! McDougall illustrates the point with a cartoon of the time (figure 1), in which Khrushchev romances the "Lesser Nations" under a Soviet moon, while the hapless suitor Uncle Sam drops his gift of candy in astonishment.

The second event occurred less than three months after John Kennedy took the Presidential oath of office. On April 12, 1961, Yuri Gagarin became the first human in space, and the first to orbit the earth. Once again, cartoons illustrate the political power of the Soviet feat (figures 2-4). American newspapers echoed Soviet views: "a psychological victory of the first magnitude"; "new evidence of Soviet superiority"; "cost the nation heavily in prestige"; "marred the political and psychological image of the country abroad"; and "neutral nations may come to believe the wave of the future is Russian." The Soviets were laying claim to the future on the power of their space program.

The third event was the final blow in the sequence of blows to U.S. self-esteem. It came just 5 days after Gagarin's flight, and it was self-inflicted. On April 17, 1961, 1450 CIA-trained Cuban expatriots landed at the Bay of Pigs. Within 24 hours their beachhead was overrun. Two hundred were killed, and 1200 were taken prisoners. The message to the world and to the U.S. public was clear: the U.S. was once again impotent in the face of the Communist revolution.

These were the challenges facing the Kennedy administration: Sputnik, Gagarin, and the Bay of Pigs. The U.S. response was molded largely by one man: Vice-President Lyndon Johnson. Johnson went to Kennedy and asked for a Presidential mandate to make recommendations about space. He got it, and returned a report so loaded with assumptions that the conclusion was inescapable: the U.S. must go to the Moon! Johnson summarized: "One can predict with confidence that failure to master space means being second-best in the crucial arena of our Cold War world. In the eyes of the world, first in space means first, period; second in space is second in everything." That the U.S. meant to be first is again illustrated in cartoons reproduced by McDougall (figures 5, 6).

Apollo was enormously successful on its own terms. Its objectives were never permanent human presence on the Moon, or even in space. Rather, its goal was to "land a man on the Moon and return him safely to Earth by the end of the decade." In accomplishing this goal, Apollo became the standard by which American's judged themselves. Standard phraseology became, "If we can put a man on the Moon, why can't we...;" and the ellipsis was filled in with "cure cancer," "end poverty," or any one of a dozen difficult and distant societal objectives.

* * * * *

The Apollo decision was underlain by a Soviet political challenge posed in technological terms. Apollo was a U.S. response in kind: a technological solution to a political problem. Technology harnessed in the service of broad state interests--technocratic government--is the theme of McDougall's book.

The U.S. and the Soviets were not alone in turning to technocracy. Robert Gilpin of Princeton University documented French technocracy in his 1968 book "France in the Age of the Scientific State." In the mid-1960s, European leaders repeatedly expressed the view that European's independence was threatened by the overwhelming scientific, technological, and economic power of the United States. France had years earlier decided to do something about it. The French "countermeasure" was to develop their own technology base. Three areas were seen as key; aerospace, energy, and electronics. These areas remain to this day the focal points of French science and technology.

French objectives in developing these technologies were at least three-fold: first, to maintain independence from both superpowers, but especially from the U.S.; second to achieve primacy within Europe; and last, to pursue Third World foreign policy objectives, particularly in former French-African colonies.

France developed several specific capabilities in pursuit of these objective. First, the force de frappe, an independent nuclear deterrent that freed France from reliance on the U.S. nuclear umbrella. Second, telecommunications and remote sensing satellite industries that rely on launchers whose development was based in part on force de frappe delivery technology. These satellite industries give France independence from the U.S. in crucial technologies and simultaneously allow it to be a supplier of services to the Third World. Third, an airframe and avionics industry which was developed to some degree at the expense of France's European neighbors. France thus became a supplier to the Third World and a challenger to the U.S., through French partnership in the Airbus Consortium, in the large airframe market, one of the few lucrative world-wide markets the U.S. still dominates. And fourth, a nuclear power industry that makes France relatively independent of Middle Eastern oil, and hence of U.S. guarantees of the continued flow of that oil.

France's post-war embrace of technocratic government was not immediately emulated by the United States. Although the "New Look" was a reliance on technology to address a fundamentally political issue, Eisenhower was wary of the downside of technocracy. He expressed his concerns most eloquently in his Farewell Address, citing economic, political, and even spiritual dangers posed by the growth of a "military-industrial complex"--a phrase he coined--and a "scientific-technological elite."

"Largely responsible for the sweeping changes in our military-industrial posture has been the technological revolution during recent decades. In this revolution, research has become critical; it also becomes more formalized, complex, and costly. A steadily increasing share is conducted by, for, or at the direction of, the Federal government. ...Partly because of the huge costs involved, a government contract becomes virtually a substitute for intellectual curiosity. ...The prospect of domination of the nation's scholars by Federal employment, project allocations, and the power of money is ever present--and is gravely to be regarded. In holding scientific research and discovery in respect, as we should, we must also be alert to the equal and opposite danger that public policy could itself become the captive of a scientific-technological elite."

But as McDougall illustrates, with Eisenhower's departure, American political resistance to technocracy faded. John Kennedy proclaimed that the torch had been passed to a younger generation, and this generation proved to be, in David Halberstam's words, the "Best and the Brightest," united in "the belief that sheer intelligence and rationality could answer and solve anything." In turning to Apollo to meet the Soviet challenge, this generation made the final transition to American technocracy.

* * * * *

One need look no further than the Strategic Defense Initiative to see that America has not retreated from technocratic government. Might technocracy and the issues confronting modern America lead it back to the Moon or beyond it to Mars? Are there factors today that could play the role that Sputnik, Yuri Gagarin, and the Bay of Pigs played two decades ago?

I think the answer is yes, and the factors are at least three. First, a redefinition of the U.S.-Soviet relationship. There is general agreement today that fundamental change is occurring in the Soviet Union. This change may lead to an equally fundamental change in the U.S.-Soviet relationship. But the process of change in that relationship is apt to be long and complex. We need to learn to work together toward common objectives - not an easy task. The intermediate Nuclear Force Treaty is a major step. Simply developing the procedures for implementing the treaty will us a lot about how to work together, and will lay both psychological and organizational foundations for future cooperation. A major space initiative with the Soviet could play a similar role. We would develop procedures and precedents for working together that could in turn provide part of a framework for cooperation in other areas. We would not transform the U.S.-Soviet relationship, but we would take a major step toward its redefinition.

The second factor acts somewhat in tension with the first, but I believe points in the same direction. That factor is the need to preserve defense industry capability in an era of arms control and declining defense budgets. Let us say the Strategic Arms Reduction Talks succeed and the U.S. and Soviet Union cut their nuclear arsenals by 50 percent. Even more important, let us say that major conventional arms cuts are also made. These developments would almost certainly lead to significant declines in real defense spending, particularly in an era of \$100-billion-dollar plus fiscal deficits. But we cannot afford to let defense industry R&D capability decline along with defense spending. Gorbachev could be overthrown tomorrow and replaced by a neo-Stalinist.

The opposition to reform in the Soviet Union is strong, and the U.S. is not about to bet its security on Gorbachev's success. Few projects have both the magnitude and character that could allow them to substitute in part for decreased defense spending. The construction of a lunar or Martian base could serve this role.

The third factor involves the Western alliance. Europe is anxious to join a major space initiative begun by the U.S. and the Soviets, since this will allow Europe to pursue its relations with both superpowers, while simultaneously developing its own technology base. But what if the United States decides to sit it out? There is little doubt that the Soviets intend to send humans beyond low earth orbit, perhaps to the Moon and eventually to Mars. The Europeans have already shown their willingness to work with the Soviets. The French have a long history of cooperation with the Soviets in space. The Germans and Soviets have just signed a space cooperation agreement. If the Soviets go out into the Solar System while the U.S. stays home, the Soviets will almost surely take our allies along with them. And that will be unacceptable to the leaders of the United States.

So what does this all boil down to? I think it boils down to a program undertaken largely for foreign policy and domestic reasons. The program would involve not only the U.S. and the Soviet Union, but Europe and Japan as well, and eventually other nations. We would not rely on the Soviets for any critical technologies or systems, but we might place such reliance on our allies. The initial goal could be either the Moon or Mars, but my hunch is the Moon won't be overlooked. And someday an array of lunar telescopes will be revealing the secrets of distant stars and galaxies.

Acknowledgment

Parts of this paper were developed while the author was a Visiting Fellow at the Woodrow Wilson School for Public and International Affairs at Princeton University. He was supported there by a MacArthur Foundation Postdoctoral Fellowship in International Peace and Security awarded by the Social Science Research Council of New York.



WHO ELSE CAN GIVE YOU A MOON?

October 13, 1957. Courtesy of the *Sacramento Bee*.

Figure 1.

Used by permission.

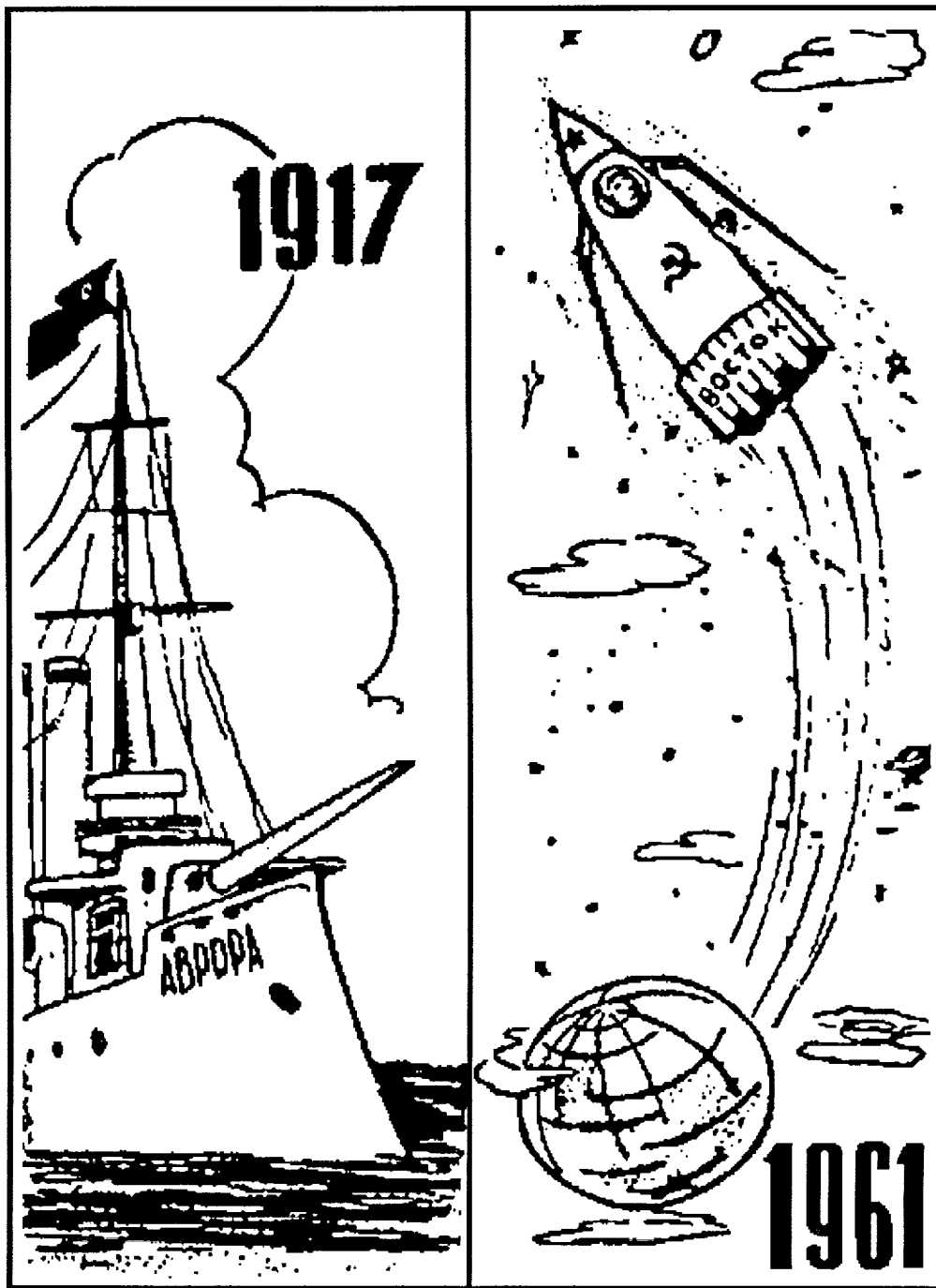

"The Dawn (Aurora) Always Heralds a New Day"

The cartoon plays on the names of the naval ship *Aurora* (the dawn), a cradle of Russian Revolutionary agitation, and *Vostok* (the East), the first manned spacecraft, implying that the future is always made in the Soviet Union. From *The Morning of the Cosmic Era* (Moscow, 1961).

Figure 2.

Used by permission.



"In Tune with the Times....Africa!"

The cartoon depicts Yuri Gagarin saluting the African people from space, implying that each is engaged in the same, mutually supporting struggle against imperialism. From *The Morning of the Cosmic Era* (Moscow, 1961).

Figure 3.

Used by permission.



"Even His Compass Won't Help Him. Which Way is West?"

The cartoon depicts two "ten-foot-tall" cosmonauts riding Vostoks III and IV to glory, while an American on his hobby-horse, intimidated by Soviet technical superiority, can no longer tell West from East. From *Izvestia*, August 1962.

Figure 4.



"Fill 'Er Up---I'm in a Race"

Herblock, May 24, 1961. Copyright 1961 by Herblock in the *Washington Post*.

Figure 5.

Used by permission.



"They Went Thataway"

From *Straight Herblock* (Simon & Schuster, 1964). Originally appeared in the *Washington Post*.

Figure 6.

Used by permission.

LUNAR INTERFEROMETRIC ASTRONOMY: SOME BASIC QUESTIONS

N. Woolf

Steward Observatory
University of ArizonaAn Alternative

It had seemed likely that many of the key technical points would have already been discussed now, and so I have brought some general questions for your consideration. When, or if there is ever an astronomical facility on the far side of the Moon, I expect to be dead. (At this point in the talk, Dr. Burke suggested that I should speak only for myself!) One cannot force the future over long periods of time. And as George Herbig once commented, in 100 years everything which we now know will be seen to be obvious, irrelevant, or wrong. Nonetheless, we have to move from the here and now, and the focus of our enquiry has to be whether we are doing something appropriate. Is this a proper use for human resources? What are our real goals? And is our concept the best match to our goals?

We are proposing an activity that is very expensive, and before the start we must answer a fundamental question. "Why do you not use this money instead to feed the starving billions?" The same question was in effect asked about the anointing at Bethany (John 12.8) and the reply was that the poor will always be with us. Our answer today can be more detailed--and more hopeful.

But first let me say that as astronomers our goal is surely to improve the quality of life, not the quantity. Up to a point quantity has survival value, but beyond that point--and we are well beyond that point--we pose a threat to humanity's own survival. We are such a large fraction of the terrestrial ecosystem that in our attempt to survive a disaster we are likely to destroy the recovery potential of the system. Our model is the reindeer population of St. Matthews island (Klein 1968). In this ecosystem a small introduced population expanded to the point that in a food shortage the deer killed off the potential for their future food. The entire population then died of starvation.

I am undoubtedly one of a very few astronomers who have computer-modelled famine. That is, I have studied the effects of environmental stochasticity producing a fluctuating food

supply, and that food supply causing population fluctuations. There will be a sigmoidal curve relating the fractional food adequacy to the death rate. And this curve allows the prediction of the number of deaths from the number alive and the available food. Undoubtedly past history of food supply and details of the food distribution must modify the shape of the curve, but this is a start in such models. I got into this study from astronomy, first by trying to understand the growth of quasar nuclei, then by modelling the population of the Mt. Graham red squirrel--but that is another story.

From the models, I can tell you that giving food and medical attention to people can be helpful in a famine--if help is in a small enough quantity. It is also possible for it to result in an increase in the number of people that will, in the future, die of starvation. Rather surprisingly, the risk of the population is reduced if the food is unevenly distributed. It is only possible to eliminate starvation by population control, that is by deliberate reduction of the birth rate or increase of the death rate. With a population balanced at an appropriately reduced level, feeding the starving masses becomes unnecessary. Without population control, the action is unhelpful because it only sets the stage for the next famine. That is, with population control there is no problem: without it there is no solution.

Science does not always give us new options; witness the laws of the thermodynamics and the limiting speed of light. In the area of population we learn that the real choices are between involuntary birth control, involuntary euthanasia, and involuntary starvation. There is no doubt in my mind that involuntary birth control is the most favorable of these choices. The mechanism is up to the couple, or country, until the limit is reached. Then it becomes a matter for everyone else.

Whether it is better to have a well-fed 100 million or 10 billion starving people is our choice. There has always been a human choice whether its goals are to produce heaven or hell. I would suggest that all past religious and ethical systems have indicated a choice in favor of the former, and there is no doubt which choice points which way. Malthus explained the problem in 1798. It is about time everybody paid attention.

True charity seeks to change the problem, not to perpetuate it. Any resources we put into this problem should go first into inculcating the message of "**Never Again**," and secondly in trying to ease the pain during the transition. With population control it is possible to build a better life here on Earth, and on the Moon.

Without it all we can do is watch more suffering while perhaps fooling ourselves that we are helping because we are spending our resources doing something that appears superficially to help others. It is possible for such activities to be stupid rather than moral. Likewise there is no simple moral issue involved in deciding whether to spend money on astronomy.

The Appropriateness of a Lunar Base and Colony

The second question is whether astronomical study is the reason for humans making a new colony on the Moon. I believe that the colony should exist regardless of whether there is an observatory, but running an observatory is an appropriate colony activity.

The ammonoid fossil on the clasp of my string tie was one of a group of creatures that existed for far longer than there have been primates on Earth, and like us the ammonoids were one of the commonest creatures of their day. They vanished as part of the catastrophe 65 million years ago that appears to have been precipitated by a collision with some small astronomical body. But not all catastrophes are the same. An earlier and even more dramatic extinction event seems quite different (Holser et al. 1989), and we have to wonder what potential ends to humanity lie beyond our current horizon of understanding.

Here on earth we are concentrated into 10^{-8} AU² in area. If we develop a self-sufficient colony on the Moon, we have expanded into an area 1000 times greater, and with the risk of extinction substantially reduced. I believe that humankind is special. We are the first to store knowledge and understanding from one generation to the next. We hold that knowledge in trust for the entire universe, at least until we encounter some similarly recording entity. That trust gives us a responsibility to avoid extinction. It is somewhat like Pascal's reason for believing in God. However low the probability of extinction in the near future may be, and however high the cost, the benefit of being prepared against it is so high as to weigh the odds in favor of that course of action. The Moon is potentially our ark.

With the potential for the Earth to become humankind's tomb, I do not believe that it is appropriate to build an isolation shelter here. Also, I do not believe that space stations allow adequate shielding of humans. Here on earth we are benefiting from a mass layer of 1Kg per square cm above our heads. Large amounts of matter for shielding are available on the Moon, but not in a space station. I do not see a substitute for the Moon.

For similar reasons we need to somewhat redirect our energies. What kinds of astronomical processes might put us at risk? For example, is there any stage of development of a main sequence Sun-like star that could precipitate a catastrophe?

Our Motives

Enough. It is time to turn the searchlight in the other direction. So it is all to be for that great store of knowledge of which science is a major part? What about the fun we are getting? Some space cowboys just want the ride. Other telescope cowboys want to ride the giant aperture. Some want to design it, plan it, build it, sell it, talk about it, ride to power using it, go out in a blaze of glory with it. We are human, and have the usual mixed motives. And even if things are done as well as they possibly can be done for science, there will be those kinds of side effects. Is it the greatest treason to do the right thing for the wrong reason, or is it a greater treason to fail to do the right thing? I must agree with Chesterton that if a thing is worth doing, it is worth doing badly.

One does the best one can with the available resources.

There is no substitute for projecting the consequences to help decide whether a course of action leads too far astray. The science needs to direct the plan, and be at the center of the design of the interferometers. We should not be surprised or dismayed by minor diversions.

As we plan for higher and higher resolution observations of the universe around us, we find that getting a long, well-controlled, and predictable baseline becomes harder and harder. The Moon is very special in providing controlled baselines of up to 3,000 km without the associated seeing problems we have here on Earth. While short baselines are fine for cutting our teeth, it is those baselines that beckon, and suggest that lunar interferometry is not just another quickie project, but rather a long-term effort for more than one generation.

We need to be very careful and thoughtful about the justification of the facility. We have already seen at this conference that the public can all too easily be sold on any project to look for planets around other stars, and particularly to look for evidence of life on those planets from the presence of oxygen. Interferometers and large telescopes both offer opportunities for this kind of search as well as a host of interesting additional science benefits. Unfortunately, the search for planets is quite specialized and very difficult at any wavelength. Searches for planets need the

experience and sophistication that are best developed by using lower precision devices first. The natural and appropriate order is to delay the planet search until our techniques are better under control.

Special Aspects of Optical Interferometry

There seem to be two aspects of optical interferometry that are quite special. The first is that the optical region offers strong spectral lines as well as continuum. Even a cursory study of the beautiful radio maps of energetic galaxies reveals the limits to interpretation because there is no spectral line information. For our optical two-element interferometers it is easy to apply spectral dispersion at right angles to the fringes. When we have a multi-element 2-D interferometer, we need to plan on the method of beam interference to preserve this possibility.

The second point is that optical wavelengths are so short that potential angular resolution is incredibly high. A 1500 km baseline at a wavelength of 5000Å is equivalent in resolution to about 1AU at 5 cm wavelength. With that resolution we could place 100 resolution elements across the disk of our Sun even if it were 1Kpc away! One hundred resolution elements are just enough for seeing sunspots. We could similarly study the surface detail of the nearest white dwarf stars. The baseline is still a little shy of resolving the velocity of light surface of the Crab Nebula pulsar. It just resolves the Schwartzchild diameter of energetic galactic nuclei.

For the galactic nuclei, the region where the material is expected to be optically thick at optical wavelengths is much larger, and interferometers with baselines of 10-100 m can yield information on orientation and structure of such regions. Even shorter baselines will start to yield the structure of the line emitting regions and allow us to relate such structures to the position angles found for radio lobes and jets.

Such observations are pointed in a direction that has been our current rationale for the study of astronomy. The universe reveals to us a range of conditions that are not met on Earth or available in even the most sophisticated laboratories. Astronomical observations allow us to check our extrapolation of laboratory experience and theoretical calculation and improve our understanding of the laws of physics and their consequences.

I would like to suggest that with our basic reason for going to the Moon--to guarantee human survival--astronomy starts to have a different and certainly more human-oriented

significance. We clearly need to shift gears to recognize this. For example, we should be very attuned to detailed confirmation of our understanding of the evolution of solar-type stars. Are there any nasty surprises that occur at intervals? Would observations of surface details in many such stars be of help? Are other stars in our galaxy going to produce unpleasant surprises?

The advent of lunar astronomical observing will prompt a reorientation of astronomers toward different goals. We hope it will also orient us toward different ways of doing things and thinking about things. I do not believe that when the time comes we will find it irrelevant that we are fundamentally inhabitants of Earth, and humans concerned with human survival. We can hope that by then it will be obvious.

References

1. Holser, W.T.; Schonlaub, H-P; Attrep, M.; Boecklemann, K.; Klein, P.; Magaritz, M.; Orth, C.J.; Fenninger, A.; Jenny, C.; Kralick, M.; Mauritsch, H Pack,E.;Schramm, J.M.; Statteger, K; Schmoller, R. 1989. Nature 337:39.
2. Klein, D.R. 1968. Journal of Wildlife Management 32:350-367.

LUNAR OPTICAL TELESCOPES: AN HISTORICAL PERSPECTIVE

Stewart W. Johnson

BDM International, Inc.
1801 Randolph Road, S.E.
Albuquerque, NM 87106

Abstract

There is a long history of thought and discussion on the possibilities of astronomical observatories on the Moon. Numerous ideas have been suggested and a variety of concepts have resulted for lunar optical telescopes. This paper reviews some of the ideas and efforts of individuals and working groups including Hershel, Clarke, Malina, Herbig, and Hess; working groups of the 1960s; and recent initiatives of Burke, Burns, and others. The enhanced technologies of the 1980s and 1990s can make past dreams of lunar observatories come to reality in the 21st century.

The Expectation

That an astronomical observatory on the Moon offers the potential advantages of emplacement on a stable platform in an environment unencumbered by atmospheric obscurations has long been recognized. The National Academy of Sciences report, Astronomy and Astrophysics for the 1980s, listed seven promising programs for the 1990s and beyond. All of these programs involved space-based observations and one of the programs was entitled Astronomical Observations on the Moon.

The report states:

The Moon offers certain decisive advantages as a base for astronomical observations. In particular the far side of the Moon provides protection from the radio interference from sources on or near Earth and therefore has great potential for radio astronomy. Shielded at all times from earthlight, sites on the far side of the Moon are also shielded from sunlight for substantial portions of each month and thus offer advantages for optical and infrared observations requiring the darkest possible sky.

The report then adds that sites on the Moon must be preserved for astronomical observations and that international planning efforts should commence for establishment of lunar observations early in the next century (Astronomy and Astrophysics for the 1980s, 1982). This paper reviews some of the history of thought relating to astronomical observatories on the Moon that has led to these conclusions regarding the advantages of the lunar surface as an observatory site.

Highlights of Past Efforts

In a recent paper, Johnson and Leonard (1985) noted that the idea of a telescope in space was mentioned in 1923 when H. Oberth, a German rocket pioneer, suggested an orbital telescope. Oberth realized the advantage of observations in space where stars do not twinkle and where there is negligible absorption in the ultraviolet and infrared (Longair and Warner 1979). Since the launch of Sputnik in 1957, many significant contributions to astronomy have been made by OAO, SAS-I (Uhuru), Ariel, ANS, Copernicus Orbiting Observatory, Skylab, OSO-7, Solar Max, Explorer, IMP and others. The Infrared Astronomy Satellite (IRAS) was a success in opening new windows to understanding the solar system and the universe. The Einstein Observatory (HEAO-2) in 1979 probed X ray sources. The Hubble Space Telescope (HST) was launched in 1990 followed by the Gamma Ray Observatory in 1991. Further in the future are the Space Infrared Facility and the Advanced X ray Astronomy Facility. The great space observatories are complementary in that they span a range of wavelengths and each of these instruments is built upon earlier successful orbiting observatories. As the generations of orbiting observatories have complemented Earth-based astronomy, the Moon-based telescopes of the future can complement terrestrial and orbital instruments.

Establishment of scientific requirements and development of conceptual designs for any space-based telescope is a lengthy and iterative process. The HST was first proposed in the early 1960s at the summer study (Longair and Warner 1979). Meetings in 1967 and 1968 by an NAS ad hoc committee discussed how a space telescope could be used. A 1974 AIAA Symposium led to additional discussion of space telescope use. The NASA Space Telescope project was initiated by an advanced study (Phase A) activity in 1971 and 1972. During 1973-1976, Phase B scientific definition studies were carried out. Final design and development (Phases C and D) began in 1977, the year that Congress approved a 2.4-m space telescope. Launch of this HST is anticipated in late 1989. The telescope is to be maintained and refurbished in orbit and may be returned to Earth for major refurbishment at 5-year intervals. The operational life of the system may be 15 years.

Discussions of the scientific potential and engineering challenges of a lunar surface telescope also began many years ago. To the astronomer, the Moon is an old friend. Kopal (1968) points out that Hipparchos knew the synodic month correctly to one second 22 centuries ago. In June 1780, William Hershel, as a young astronomer, wrote in a letter to the Astronomer Royal, "What a glorious View of the heavens from the Moon!" He went on to state that "For my part, were I to chuse between the Earth and the Moon, I should not hesitate a moment to fix upon the Moon for my habitation" (Kopal 1968).

Arthur C. Clarke in a 1954 book (Clarke and Smith) wrote that it is difficult to overestimate the value of the Moon as a site for astronomical observations. Earth telescopes transported to the Moon could be used at tenfold their efficiency on Earth. He acknowledged that special telescopes would be required for lunar conditions.

In 1964, a Lunar International Laboratory (LIL) panel anticipated a manned, permanent research center on the Moon. At the International Academy of Astronautics Lunar International Laboratory Project Symposium in Athens in 1965, it was noted (Malina 1969) that the Moon "represents... an ideal place to site an observatory for both optical and radio telescopes." Figures 1-3 illustrate concepts for lunar observatories suggested at the LIL Symposium (Malina 1969).

Herbig of Lick Observatory (North American Aviation, 1965a and 1965b) believed that the lunar telescope could be justified from a scientific point of view. Conferees at Falmouth (Astronomy Study Group 1965), Woods Hole (Working Group on Optical Astronomy 1966), and Santa Cruz (Astronomy Working Group 1967) investigated possibilities for lunar astronomical observatories.

NAS Space Science Board, 1965

Under the leadership of Harry H. Hess, Chairman, the Space Science Board of the National Academy of Sciences was convened at Woods Hole, Massachusetts, in 1965 to set directions for the future of space research. The Working Group on Optical Astronomy chaired by Lyman Spitzer met in June and July 1965 and recommended that in the time period 1965-1975, two or more 40-in aperture or larger telescopes be placed on the Moon as a part of the Apollo Extension Systems Program. They stated that the development of optical interferometers should be pressed with initial operation on Earth (Working Group on Optical Astronomy, 1966). They gave strong support

to a large diameter (120 in or more) orbiting telescope and emphasized the need for research and development of space telescope optics.

Research objectives of significance to the group at Woods Hole were listed:

1. Is the universe infinite or finite?
2. Is the universe steady state?
3. Are some physical laws still undiscovered?
4. Did all chemical elements build up from hydrogen?
5. How are stellar systems, stars, and planets formed?

They recognized that some key questions in astronomy would not be answered without space telescopes. Cited as such key questions were the cosmic distance scale, structures in galactic nuclei, molecular hydrogen distribution, and interstellar clouds radiating energy at about 100 microns.

The group at Woods Hole felt it was initially essential to test the ability of the astronaut to adjust, maintain, repair, and occasionally operate a large telescope in space.

NASA 1965 Summer Conference

In July 1965, the National Aeronautics and Space Administration conducted a Lunar Exploration and Science Conference in Falmouth, Massachusetts, under the leadership of Richard Allenby (Astronomy Study Group 1965). This conference followed the National Academy of Sciences Space Science Summer Study (Working Group on Optical Astronomy 1966) at Woods Hole, Massachusetts. At the Falmouth meeting, the special Astronomy Study Group convened by Nancy Roman of NASA had the following members: C. Fichtel, NASA Headquarters; K.G. Henize, Northwestern University; W. Markowitz, Naval Observatory; T.A. Mathews, California Institute of Technology; N.U. Mayall, Kitt Peak; John Naugle, NASA Headquarters; E.J. Ott, NASA Headquarters; E.E. Salpeter, Cornell University; and R.G. Stone, Goddard Space Flight Center, NASA.

Their recommended program was to encompass a 10-year period beginning with the first Apollo flights and considering scientific contributions by both manned and unmanned vehicles. The study was based on the likely capabilities of an Apollo Extension System (AES) which was to

make possible longer stay times, extended exploration capabilities, and support of lunar astronomy experiments (North American Aviation 1965b). This Astronomy Study Group made the following resolutions:

The group considered that the Moon offered an attractive and possibly unique base for astronomical observations and recommended evaluation of the lunar environment, including engineering properties and testing, with small telescopes on the Moon.

It was felt to be extremely important to start feasibility studies for a dish of approximately 100-f diameter to be used between millimeter and infrared wavelengths.

The group considered the information to be gained from radio astronomy observations at frequencies between 10MHz and 50kHz to be of considerable importance and recommended that a feasibility study should be started to determine whether the antenna should be placed in high Earth orbit or on the lunar surface, and the type of antenna to be used. Information about the lunar environment was needed to decide whether the Moon was a suitable place.

The major environmental areas requiring study were discussed for radio, optical and X- and gamma-ray astronomy and were listed as follows:

Radio Astronomy

1. Mechanical properties (bearing strength, stability, etc.)
2. Electrostatic charge (dust and surface rock)
3. Background noise (radio interference from Earth or spacecraft)
4. Impedance and dielectric properties (lunar subsurface)

Optical Astronomy

1. Mechanical properties (bearing strength, stability, etc.)
2. Micrometeoroids (primary and secondary flux, erosion of mirrors, etc.)
3. Light background (luminescence, dust and atmosphere)
4. Thermal environment (above, on, and below the surface both lunar day and night)
5. Surface characteristics (reference points on Moon)

X- and Gamma-Ray Astronomy

1. X-ray background (from solar wind, cosmic ray, bombardment, etc.)
2. Gamma-ray background (radioactivity, etc.)

Adequate environmental data were not available in 1965, and the importance for all branches of astronomy of understanding the lunar environment was emphasized. It was concluded that the engineering and design of astronomical facilities on the Moon must proceed from an understanding of lunar environmental data.

NASA 1967 Summer Conference

At Santa Barbara, California, in 1967 the Astronomy Working Group had the following members: L.W. Fredrick, Chairman, University of Virginia; N.G. Roman, Cochairman, NASA Headquarters; R.C. Stokes, Secretary, NASA, Manned Spacecraft Center; S.L. Sharpless, University of Rochester; W.G. Tiff, University of Arizona; G.W. Simon, Sacramento Peak Observatory; W.R. Sheeley, Kitt Peak National Observatory; G.P. Garmire, California Institute of Technology; G.G. Fazio, Smithsonian Astrophysical Laboratories; R.G. Stone, NASA Goddard Space Flight Center; and S.J. Goldstein, University of Virginia.

The 1967 working group also defined a series of measurements to obtain data fundamental to the establishment of a lunar astronomical base. Measurements and instruments for making these measurements were listed and close cooperation between astronomers and other scientists in the final planning was recommended.

The four areas of astronomy considered were radio, X-ray and γ -ray, nonsolar optical, and solar optical astronomy. The report of this working group stated that radio astronomy, X-ray astronomy, and γ -ray astronomy require observations that probably can be made better on the lunar surface than in any other place. Optical astronomers were to decide the question of Earth-orbital versus lunar-based observations after obtaining more information on the lunar environment and comparisons with orbital experience.

The 1967 working group suggested that a single site may be suitable for all of the astronomical observations. They stated that X-ray and γ -ray occultation experiments require a

crater with a 50-km radius, the rim of which stands 1 km or more above a fairly flat crater floor. Radio astronomy requires an area of about 30 by 60 km. A site near the lunar equator was preferred. Optical astronomers preferred a site near the limb.

The following environmental characteristics of the lunar surface were listed for determination:

1. Micrometeorite environment.
2. Radiofrequency noise levels
3. Surface impedance and conductivity
4. Density and extent of the lunar ionosphere (if it exists)
5. X-ray and γ -ray intensities, including the zenith-angle distribution of the intensities.
6. Soil mechanics such as bearing strength and stability, depth profiles of temperature, seismic activity, and ionizing radiation
7. Thermal effects on astronomical instrumentation
8. Contaminants such as dust, spacecraft outgassing, spacecraft radiofrequency interference, and astronaut seismic noises
9. Deterioration of precision optical surfaces
10. Evaporation rates for optical coatings

It was noted that the Moon offers long-range advantages over Earth orbiting experiments. It is an extremely stable platform with a slow rotation rate which can be determined with high precision. A distant horizon can provide an excellent occulting edge for the determination of position and angular size of sources over a wide range of wavelengths to an accuracy probably unattainable with Earth orbiting instruments. Very long exposure times in combination with large area detectors can be used to achieve great sensitivity. Complex, large area experiments demanding relatively frequent servicing over long periods of time, can be best performed on the Moon.

Evaluation of the Moon as a site for a large telescope for optical astronomy with consideration given to environmental factors (that is, can large telescopes be operated on the Moon) and to scientific factors (that is, should large telescopes be operated on the Moon) is the central task for the early lunar astronomy program. The lunar investigation should begin with small site-testing packages and gradually incorporate more scientific packages to examine

operational and astronomical engineering problems and to demonstrate the extent to which the Moon offers unique advantages for optical astronomy.

According to the following excerpts from the 1967 Astronomy Working Group reports, the Moon may offer both scientific and environmental advantages over orbital systems:

1. The lunar night on or near the lunar far side offers the ultimate in minimizing background light and noise for faint-signal discrimination. In orbit, the primary light sources of the Sun, Earth, and Moon combine with complex time-dependent view patterns, scattering from structures, contaminants, and local radiation noise to degrade the ultimate signal-to-noise ratio obtainable.

2. The lunar horizon occults the Sun and thus permits near-solar access for measurements of the inner planets, comets, zodiacal light, and outer coronal features. Orbital systems become highly constrained within about 45° of the sunline.

3. The Moon provides a platform with a known time coordinate system which allows highly predictable and rapidly programmable orientation control, programmable drive, and single-star guidance control.

Other factors that offer advantages for specific problems include the following:

1. Access to virtually every point in the sky (in the dark) every lunar month for relatively long, uninterrupted periods

2. Availability of local radiation shielding so that film can be protected for long periods against cosmic rays

3. Minimal velocity-dependent effects such as differential aberration and Doppler shift during an observation

4. Low local magnetic fields

5. Flexibility of the manned interface

6. Long-term growth, self support, and operational flexibility

7. Location outside the geocorona of the Earth which will reduce the Lyman- α background brightness

The astronomical site suggested would be near but slightly south of the equatorial plane to provide favorable access to the Megallanic clouds which lie close to the south lunar rotational pole. If the southern latitude is too great, an appreciable segment of the sky will be lost in the north circumpolar cap. A desirable latitude range appears to be -5° to $\pm 3^\circ$.

The site for the very large telescope should be on the far side of the Moon, continuously beyond the visible range of the Earth, to achieve the best dark conditions through the elimination of earthlight. There is no optical requirement that the site be more than slightly beyond the maximum libration limb, and a site which libration occasionally brings into view of the Earth is acceptable. Since the ultimate desirability of farside operations may present an initial operational restriction, early exploration may be desirable for a second near-side limb site with a longitude from the central meridian of $75^\circ \pm 10^\circ$.

The two near-side limb sites lie near Grimaldi and Langrenus. Both areas have moderately broken terrain. The terrain at the final site should be fairly flat without great local roughness or an irregular horizon. The southern horizon, particularly, should be unobstructed. A slight elevation favoring southern exposure and perhaps somewhat above the lowest levels of the possible secondary ejecta haze should be considered. The highest site altitude that can be achieved without recourse to very rugged terrain may be advantageous.

The Large Optical Observatory

In a 1965 study for NASA (North American Aviation 1965a), G.H. Herbig of Lick Observatory listed four conditions that an optical telescope on the Moon should satisfy:

1. The telescope must operate effectively in the 1000 to 1500 \AA region (as well as at longer wave lengths). An aperture of at least 100 in was specified for a diffraction-limited telescope to operate effectively in this region.

2. Astronomers using the instrument should be adequately shielded and able to work using fixed receiver operable without the encumbrance offered by spacesuits.

3. The most valuable optics must be protected against possible damage and misalignments owing to temperature changes and particle impact.

4. The design of the telescope systems should take into account the nature of the lunar environment, the high cost of transporting massive movable structures to the Moon, and the relatively high cost of construction and operation manhours expended on the Moon.

Herbig suggested that a fixed horizontal telescope with the following components could be established on the Moon:

1. A reflector in a fixed position in a tunnel and not exposed directly to the lunar sky.
2. A single moving flat mirror exposed to the outside. This mirror would be driven by a servomechanism programmed for observations from the Moon. Radiation incident on this mirror would be reflected through a tunnel to the reflector.
3. A grating spectrograph mounted at a focus of the telescope and operable from a environment in which astronomers could work without pressurized suits.
4. A pressurized and well-equipped laboratory having access to a large-scale focus. Here would be the instruments required for investigating star images formed in the focal plane.

A possible configuration of the horizontal telescope is shown in figure 4. The estimated Earth weight delivered to the surface of the Moon (North American Aviation 1966b) would have been 18,000 k (39,600 lb). A vertical telescope was subsequently considered requiring mounting the 200-in flat mirror directly above rather than to the side of the 100-in reflector.

The 100-in telescope would have required an advanced space transportation system to reduce the costs of lunar payload delivery. The telescope would have been part of a previously established manned lunar base that housed construction engineers and furnished power and other support to the observatory during and after construction and checkout. This discussion stated that

a lunar observatory of this configuration might be 15 to 20 years in the future but it was a worthy goal.

A Lockheed (1967) MIMOSA Program to commence in 1971 and extend until 1988 involved 1-m optical telescopes set up at the south pole and the center of the farside to evaluate the potential of lunar-based astronomy. A 12-man permanent base in the crater Grimaldi was to use an array of radio, optical, and X ray telescopes. MIMOSA was based on an upgraded Saturn V launch rate of three to four per year through the 1970s and six per year in the 1980s.

Hynek and Powers (1970) proposed a design for a small photometer to be used for observatory site surveys on the Moon. Their goal was to monitor background brightness in the range of wavelengths from Lyman- α to the visual and scattered light as a function of elevation and deterioration of optics. They valued the Moon as a site because of its predictable motions, its capacity to absorb heat as well as angular momentum, the Moon's slow rate of rotation, and the location away from Van Allen belts and Earth-centered debris in space. They argued for a 25.4-cm telescope to be placed on the Moon to do a galaxy count in the near infrared.

Constructing an Observatory on the Moon

Johnson et al. (1971) used Surveyor and Apollo mission soil mechanics and other results in an investigation of the lunar regolith as a site for an astronomical observatory. A telescope system was postulated involving a large reflector, and foundations were designed for cases of a deep regolith and a shallow regolith. It was noted that the lunar soil is fine-grained, relatively dense, and weakly cohesive and will support anticipated observatory loads with proper design of foundation components. More information is needed on the behavior of the surface under repeated and dynamic loads.

There are known to be significant variations in the lunar soil both laterally and with depth as revealed by trenching and core tubes (Johnson and Carrier 1971; Carrier et al. 1972). In emplacing an observatory on the Moon, it will be necessary to have knowledge of soil and rock profiles and engineering properties at depth and to monitor soil and foundation behavior during observatory placement. It may be feasible to compact or stabilize the regolith. The wide range in lunar temperatures implies a thermal cycling (and expansion and contraction) of the regolith, suggesting that foundations should be placed below the depth of thermal cycling. Both total and differential settlements are to be controlled appropriately.

Previously, Johnson (1964) considered criteria for lunar base structures, taking into account gravitational, vacuum, and other effects. Since the 1960s, a variety of new materials and control technologies have been developed that offer promise for a use in design of a lunar observatory. The materials include graphite epoxy and metal matrix composites with low coefficients of thermal expansion and high strength and stiffness. The controls technologies are consistent with progress in adaptive optics. Early facilities will probably be fabricated on Earth but later facilities may be partly constructed with materials made from lunar resources. Sensitive components will be shielded by burial in the lunar regolith. Air-inflated structures offer the possibility of providing mobile repair hangars that could be used at remote observatory sites.

When robots and automated construction equipment are used on the Moon, consideration will have to be given to a myriad of design details. For example, connections and hookups (e.g., for fluids) must take a positive connection with little adjustment required. Semiautonomous construction equipment offers the possibility of providing tremendous cost savings in building and maintaining a lunar observatory. Developments on Earth are already validating concepts of semiautonomous telecommanded systems of construction and exploratory vehicles and equipment for use in hazardous environments and in military contexts.

Recent Proposals

There have been two conferences on Lunar Bases and Space Activities in the 21st Century, and at both conferences (in 1984 and 1988) the possibilities of lunar observatories have been discussed. The idea of a lunar optical/infrared synthesis array was presented by Burke (1984) at the 1984 conference.

At a January 1986 meeting in Houston, Texas, attended by about 100 astronomers, space scientists, physicists, and engineers, the challenge was to consider astronomical observations from a lunar base. Burns (Burns and Mendell 1988) noted there was a remarkable consensus from this group that the Moon is very likely the best location in the inner solar system to site an observatory for cutting-edge research in astronomy.

In August 1988, at a conference on Engineering, Construction, and Operations in Space, five papers relating to lunar observatories were presented and three of these were published in the proceedings (Johnson and Wetzel 1988). These papers described modest astronomy facilities for

an early lunar base and, later, more elaborate facilities (Burns 1988b; Zeilik 1988) as well as needed advanced technologies (Johnson and Wetzel 1988) such as light-weight steerable parabolic antennae (Akgul, Gertsle, and Johnson 1988). Also considered were transient atmospheres resulting from human activities on the Moon and the persistence and possible detrimental effects of these gas clouds on the effectiveness of lunar astronomical observatories (Fernini et al. 1988).

The Office of Exploration 1988 Annual Report to the NASA Administrator identified three pathways for human exploration of the Moon and Mars. Each begins from Space Station Freedom and for each pathway, candidate missions were identified as case studies. One of the four candidates is a lunar observatory. The lunar observatory case study has as its objective an understanding of the effort to construct and operate a human-tended farside lunar observatory with optical arrays, stellar monitoring capability, and radio telescopes (Office of Exploration 1988a and 1988b).

Summary and Conclusions

Suggestions for astronomical observatories in space date back at least to Herman Oberth in 1923. The desirability of telescopes on the Moon was apparently alluded to by Hershel in 1790. A more specific rationale was stated in 1954 by Arthur C. Clarke. Malina and coworkers offered design concepts for telescopes on the Moon in the 1960s. Several different working groups convened in the 1960s developed ideas for observatories on the Moon and listed information needed on the lunar environment to facilitate engineering designs. The importance of the optical interferometer was recognized (circa 1965) in these working group discussions. Several aerospace companies were engaged by NASA to develop design concepts for lunar observatories in the 1960s.

In the 1980s and 1990s, the technologies for lunar observatories encompass light-weight thin mirrors, adaptive optics, controls, robotics, fiber-reinforced composite materials, advanced sensors, and improved data storage and processing and transmission capabilities. The dreams of the 50s and 60s for lunar observatories are becoming more readily achievable. Results from Apollo lunar missions are available. What remains to be done is to mount a steady effort to establish an optical telescope on the Moon. A step-by-step effort can achieve the goal of a significant functioning optical interferometer on the Moon in the 21st Century.

Acknowledgments

The author is grateful for the support of BDM International, the University of New Mexico, and the National Aeronautics and Space Administration (Grant NAG 9-245) in the preparation of this paper. The excellent editing and word processing efforts of Jean K. Helmick in the preparation of the text are acknowledged.

References

1. Akgul, F.; Gerstle, W.; Johnson, S.W. 1988. Presentation on a lunar steerable parabolic dish design at Space 88 conference, Albuquerque, New Mexico, August 29-31.
2. Astronomy and Astrophysics for the 1980s. 1982 vol. I, Report of the Astronomy Survey Committee of the Assembly of Mathematical and Physical Sciences, National Research Council, National Academy Press, Washington, DC, pp.165-166.
3. Astronomy Study Group. 1965. In NASA 1965 Summer Conference on Lunar Exploration and Science, Falmouth, Mass, NASA SP-88, pp. 369-393.
4. Astronomy Working Group. 1967. In 1967 Summer Study of Lunar Science and Exploration, Santa Cruz, California, NASA SP-157, pp. 369-398.
5. Burke, B.F. 1984. Astronomical Interferometry on the Moon, W.W. Mendell, editor, Lunar Bases and Space Activities of the 21st Century, Lunar Planetary Institute, Houston, Texas, pp. 281-291.
6. Burns, J.O. 1988a. 21st Century Astronomical on the Moon, in Engineering, Construction, and Operations in Space, S.W. Johnson and J.P. Wetzel, editors, American Society of Civil Engineers, NY, NY (1988).
7. Burns, J.O.; Mendell, W. W. editors. 1988. Future Astronomical Observatories on the Moon, NASA Conference Publication 2489, Proceedings of a Jan. 10, 1986 Workshop in Houston, Texas, 134 pages.

8. Carrier, W.D. III; Johnson, S.W. ; Carrasco, L.H.; Schmidt, R. 1972. Core Sample Depth Relationships: Apollo 14 and 15 *Geochim. Cosmochim. Acta*, 3: 3213-3221.
9. Clarke, A.C.; Smith, R.A. 1954. *The Exploration of the Moon*, Harper and Brothers, New York, 112 pages.
10. Fernini, I. et al. 1988. Presentation on lunar artificial atmosphere generated on Moon by human activities at Space 88 conference, Albuquerque, New Mexico, August 29-31.
11. Hynek, J.A.; Powers, W.T. 1970. Astronomical Instruments on the Moon, in *Applied Sciences Research and Utilization of Lunar Resources, Proceedings of the Fourth Lunar International Laboratory (LIL) Symposium*, Pergamon Press, Oxford, 1970, pp. 141-186.
12. Johnson, S.W. 1964. *Criteria for the Design of Structures for a Permanent Lunar Base*. PhD. Thesis, University of Illinois, Urbana, Illinois. 177 pages.
13. Johnson, S.W.; Carrier, W.D. III. 1971. Lunar soil mechanics. *The Military Engineer*, 63:324-328.
14. Johnson, S.W.; Leonard, R.S. 1984. Lunar-based platforms for an astronomical observatory, in *Proceedings of National Symposium and Workshop on Optical Platforms*, C.L. Wyman, ed., vol. 493, Society of Photo-Optical Instrumentation Engineers, Bellingham, Washington, pp. 147-158.
15. Johnson, S.W.; Leonard R. S. 1985. *Design of Lunar-Based Facilities: The Challenge of a Lunar Observatory, Lunar Bases and Space Activities in the 21st Century*, W.W. Mendell, ed., Lunar and Planetary Institute, Houston, Texas, pp. 413-422.
16. Johnson, S.W.; Rohloff, K.J.; Whitmire, J.N.; Pyrz, A.P.; Ullrich, G.W.; Lee D.G. 1971. The lunar regolith as a site for an astronomical observatory, in *Proceedings of the Ninth International Symposium on Space Technology and Science*, M. Uemura, ed. AGNE Publishing, Inc. Tokyo, pp. 1059-1076.

17. Johnson, S.W.; Wetzel J.P. 1988a. Advanced Technology for a Lunar Astronomical Observatory, in Engineering, Construction, and Operations in Space, American Society of Civil Engineers, New York.
18. Johnson, S.W.; Wetzel, J.P., eds. 1988b. Engineering, Construction, and Operations in Space, American Society of Civil Engineers, New York, 1,349 pages.
19. Kopal, Z. 1968. Exploration of the Moon by Spacecraft, Oliver and Boyd Ltd., Edinburgh, 88 pages.
20. Lockheed. 1965. Deployment Procedures, Lunar Exploration Systems for Apollo, Volume I, Summary, Lockheed Missiles and Space Company, LMSC-665606-I, Sunnyvale, California, pp. 16-18.
21. Lockheed. 1967. Study of Mission Modes and System Analysis for Lunar Exploration (MIMOSA), Final Report, Recommended Lunar Exploration Plan, vol. III. LMSC-A847942, Lockheed Missiles and Space Company, Sunnyvale, California, 154 pages.
22. Longair, M.S.; Warner, J.W., eds. 1979. Scientific Research with the Space Telescope. International Astronomical Union Colloquium, no. 54, Princeton, New Jersey, 327 pages.
23. Malina, F.J. 1969. The lunar laboratory. Sci. J. (Special Issue: Man on the Moon) 5: 108-113.
24. North American Aviation. 1965a. A Study of Scientific Mission Support of a Lunar Exploration, Final Report, vol. III, Scientific Studies, Part 2, North American Aviation, Inc., SID 65-289-3 (X65-16494), pp. 235-243.
25. North American Aviation. 1965b. A Study of Scientific Mission Support for Lunar Exploration Systems for Apollo, SID 65-289-4.
26. North American Aviation. 1966a. Scientific Mission Support for Extended Lunar Exploration, Final Report, vol. 1, Condensed Summary, North American Aviation, Inc., SID 66-957-1 (N67-34087), pp. 23-24.

27. North American Aviation. 1966b. Scientific Mission Support for Extended Lunar Exploration, Final Report, vol. 3, Detailed Technical Report, North American Aviation, Inc. SID 66-957-3 (N67-34106), pp. 273-288.
28. Office of Exploration. 1988a. Beyond Earth's Boundaries: Human Exploration of the Solar System in the 21st Century, Annual Report to the Administrator, NASA, 51 pages.
29. Office of Exploration. 1988b. Exploration Studies Technical Report FY 1988 status, vol. 1 - Technical Summary, NASA, 47 pages.
30. Working Group on Optical Astronomy. 1966. In Part 2 of Space Research: Directions for the Future, Woods Hole, Massachusetts, Space Science Board, National Academy of Sciences, Washington, D.C., pp. 1-30.
31. Zeilik, M. 1988. Lunar Automatic Photoelectric Telescopes (LAPTs), in Engineering, Construction, and Operations in Space, S.W. Johnson and J. P. Wetzell, eds., American Society of Civil Engineers, New York.

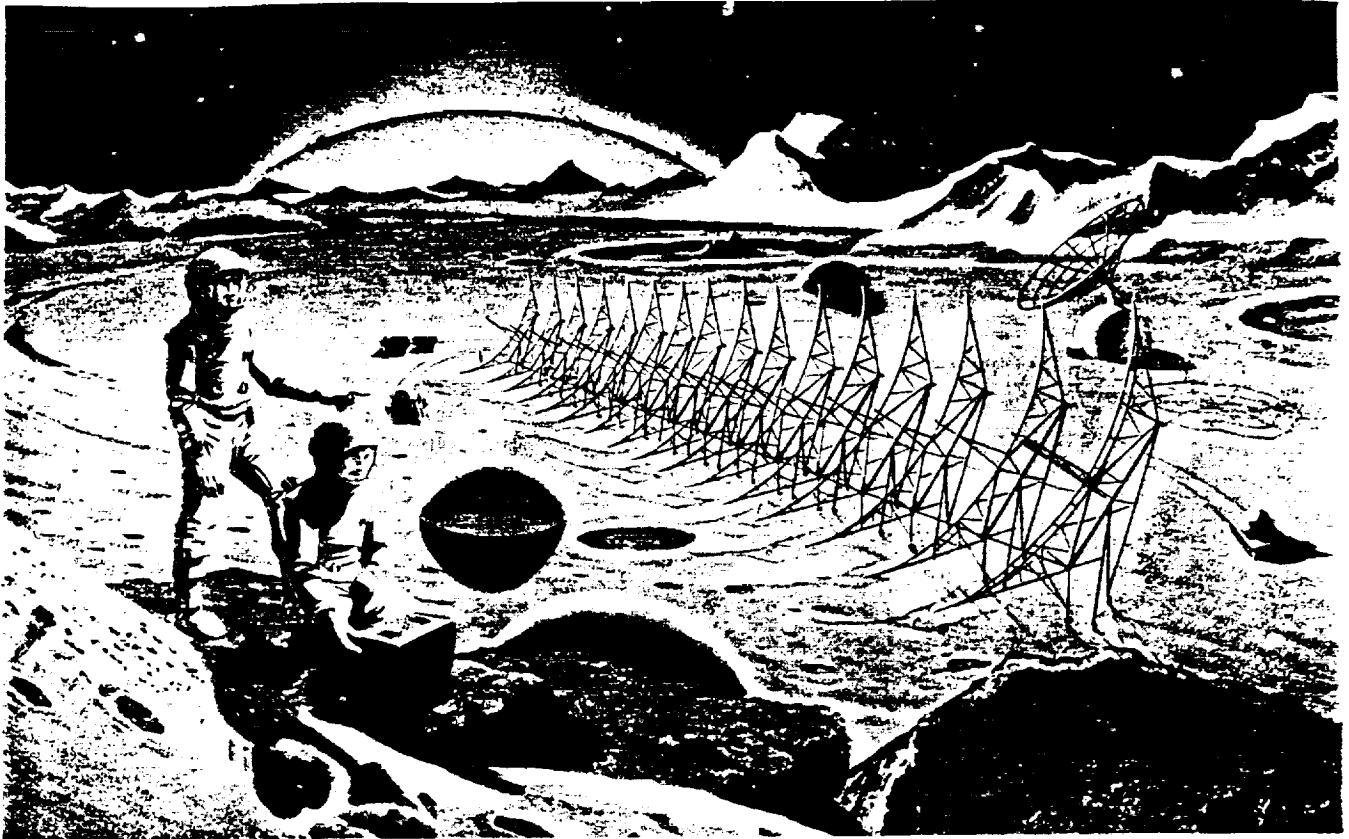

Figure 1: Radio astronomy from the Moon has three advantages over terrestrial observation: man-made, terrestrial-originating background noise is avoided (particularly on the far side); there is less gravitational pull to cause distortions in the structures; and there is a slower period of rotation relative to objects being observed (from Malina 1969).

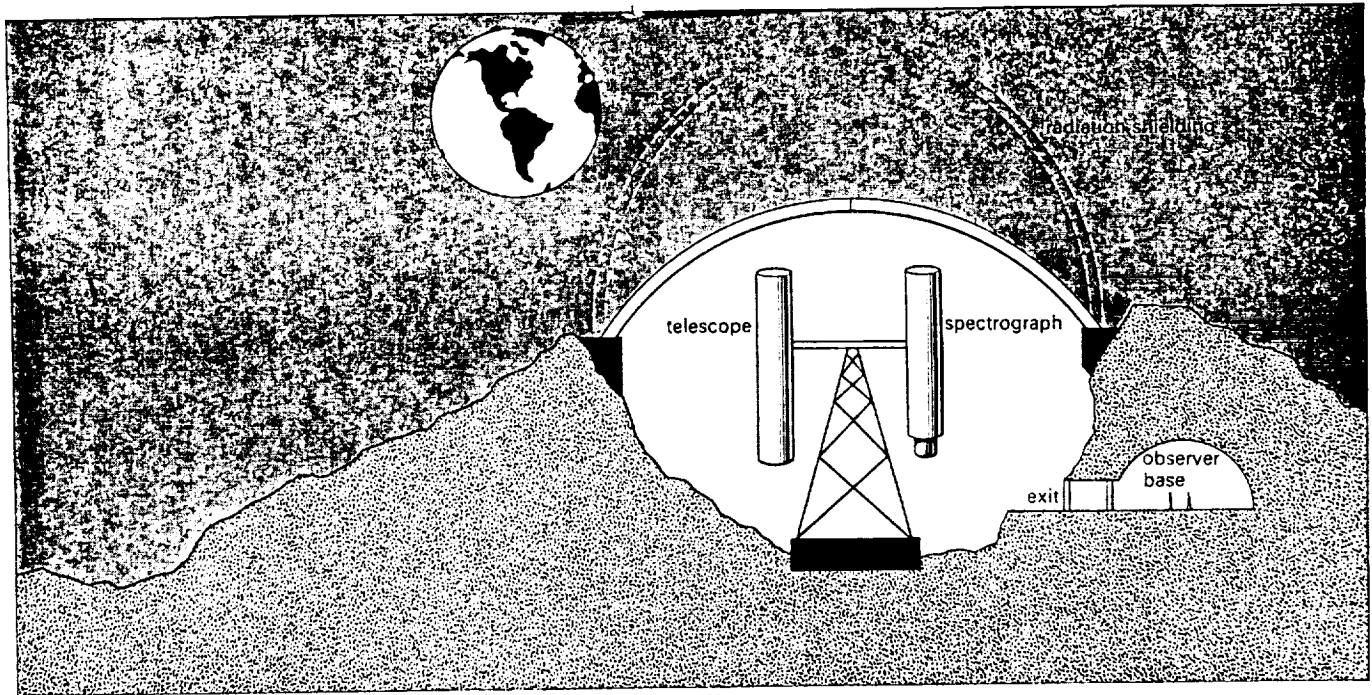

Figure 2: The Lunar International Symposium (LIL) of 1965 suggested this semi-permanent observatory in a small lunar crater. Radiation shielding lids of expanded foam materials are shown (Malina 1969).

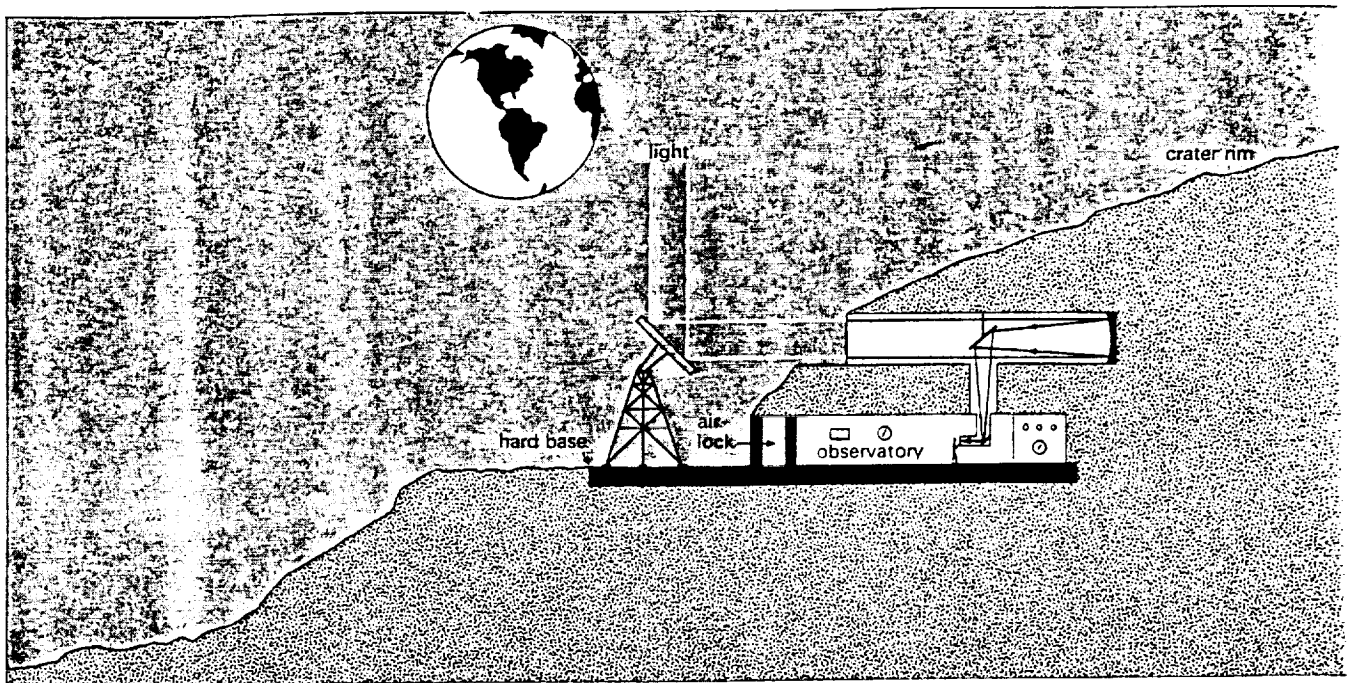
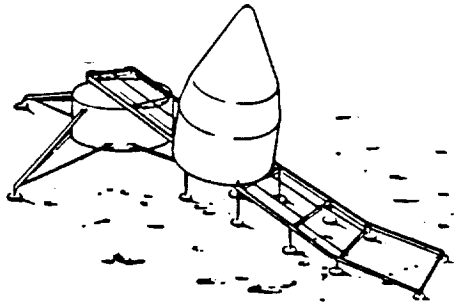
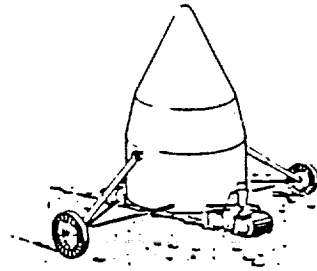

Figure 3: This fixed-based observatory was also proposed at LIL such that sensitive equipment could be protected by a considerable thickness of lunar soil and rock (Malina 1969).



UNLOAD FROM LUNAR LANDING VEHICLE



TRANSPORT TO OBSERVATORY SITE

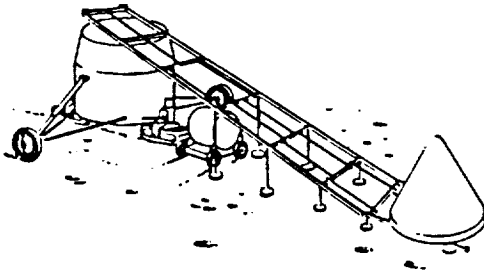

DEPLOY PRIMARY MIRROR SYSTEM AND INSTRUMENT ROOM

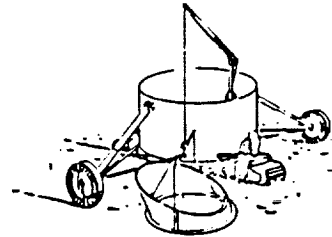

UNLOAD COMPONENTS WITH DAVIT

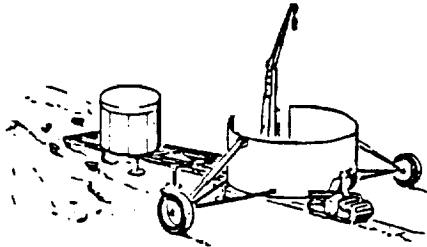

UNLOAD 200-IN. SIDEROSTAT

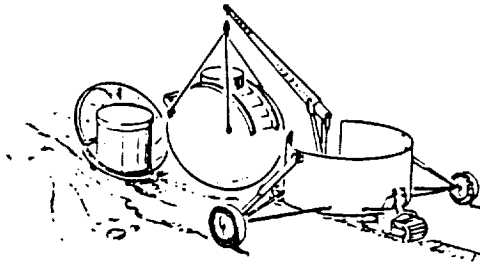

INSTALL DOME SEGMENTS

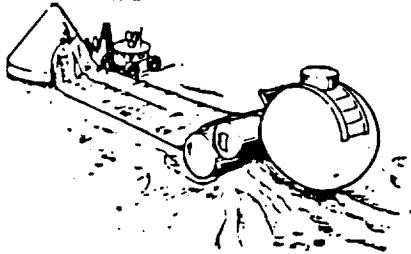

DEPLOY INFLATABLE TUNNEL

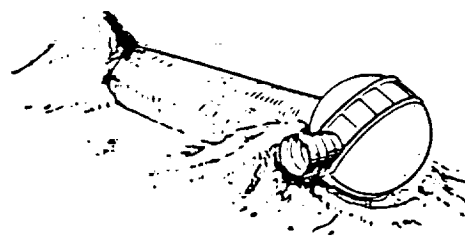

ALIGN OPTICS; ACTIVATE AND CHECK OUT

Figure 4: Deployment of 100-in. horizontal telescope.

THE LUNAR ENVIRONMENT AND ITS EFFECT ON OPTICAL ASTRONOMY

G. Jeffrey Taylor

Hawaii Institute of Geophysics
 University of Hawaii
 Honolulu, HI 90822

Abstract

The Moon's geologic environment features 1) gravity field one-sixth that of Earth; 2) sidereal rotation period of 27.3 days; 3) surface with greater curvature than Earth's surface (a chord along a 10-km baseline would have a bulge of 7.2 m); 4) seismically and tidally stable platform on which to make astronomical observations (most moonquakes have magnitudes of 1 to 2 on the Richter scale, within the Earth's seismic noise, resulting in ground motions only 1 nm); 5) tenuous atmosphere (the total mass at night is only 10^4 kg) that has an optical depth of 10^{-6} and does not cause wind-induced stresses and vibrations on structures; 6) large diurnal temperature variation (100° to 385°K in equatorial regions), which telescopes must be designed to withstand; 7) weak magnetic field, ranging from 3 to 330×10^{-9} T, compared to 3×10^{-5} T on Earth at the equator; 8) surface exposed to radiation, the most dangerous of which are high-energy (1-100 Mev) particles resulting from solar flares; 9) high flux of micrometeorites which are not slowed down from their cosmic velocities because of the lack of air (data indicate that microcraters $> 10 \mu\text{m}$ across will form at the rate of $3000/\text{m}^2/\text{yr}$); 10) regolith 2 to 30 m thick which blankets the entire lunar surface (this layer is fine-grained (average grain sizes range from 40 to $268 \mu\text{m}$), has a low density (800 to $1000 \text{kg}/\text{m}^3$ in the upper few millimeters, rising to 1500 to $1800 \text{kg}/\text{m}^3$ at depths of 10-20 cm), is porous (35-45 percent, cohesive (0.1 to $1.0 \text{kN}/\text{m}^2$), and has a low thermal diffusivity (0.7 to $1.0 \times 10^{-8} \text{m}^2/\text{sec}$); about 29 percent of the regolith is $< 20 \mu\text{m}$ in size--this dust could pose a hazard to optical telescopes); 11) rubble upper several hundred meters in which intact bedrock is uncommon, especially in the lunar highlands; and 12) craters with diameter-to-depth ratios of 5 if fresh and < 15 km across (larger and eroded craters have diameter-to-depth ratios > 5).

Introduction

The environment at the Moon's surface makes it nearly ideal for astronomical observations. It is dramatically different from Earth's environment and presents fascinating

challenges to engineers designing observatories on the lunar surface. Some of the virtues of the lunar environment for observations can also damage equipment. This paper summarizes the nature of the lunar surface, its tenuous atmosphere, and its radiation environment.

Small Size and Rotation Rate

The strength of the Moon's gravitational field is about one-sixth that at Earth's surface; the surface gravity is 1.62 m/s^2 and the escape velocity is 2.37 km/s . The lower gravity allows use of materials of lower strength than on Earth for structures of equivalent size. Alternatively, much larger structures can be built on the Moon. The Moon has a slow sidereal (the time it takes to complete one revolution) rotation period of 27.3 Earth days, so days and nights each last almost 2 weeks. Consequently, observing times are long, but solar energy systems require some way to store energy during the long lunar night. Finally, because of the Moon's smaller radius, its surface has a larger curvature than does the Earth's surface. For example, a chord along a 10-km baseline would have a bulge along it of 7.2 m; a 60-km baseline would have a bulge of 260 meters.

Stable Platform

The Moon provides a stable platform on which to build structures. Seismic properties are summarized in table 1, which is adapted from Goins et al. (1981). There are two main categories of lunar seismic signals, based on the depth at which they originate. Almost all occur deep within the Moon at depths of 700 to 1100 km; on the average, about 500 deep events were recorded each year during the 8 years that the Apollo network operated. These deep moonquakes are related to tidal forces inside the Moon.

Moonquakes also occur at much shallower depths (<200 km), but apparently below the crust (Nakamura et al. 1979). They occur much less frequently than do deep moonquakes, only about 5/y. Shallow moonquakes do not appear to be related to tidal flexing of the Moon or to surface features. For comparison, most earthquakes occur at depth of 50 to 200 km.

Lunar seismic activity is drastically less than terrestrial seismicity (table 1). Lunar seismographs detected only 500 quakes per year. In contrast, 10,000 detectable quakes occur each year on Earth. Note that the magnitudes of detectable quakes is different on Earth and the Moon, due mostly to greater seismic noise on Earth. In fact, most moonquakes are in the magnitude 1 to 2

range on the Richter scale, which is in the Earth's seismic background. The weak lunar seismic background produces ground motions that are astonishingly small, only about 1 nm.

Seismic waves are intensely scattered near the lunar surface. This causes the energy of the waves arriving at a given point to be spread out, so the damaging effects of a moonquake would be less than those of an earthquake of the same magnitude. (In fact, values of seismic energy and magnitudes reported for the Moon by Goins et al. (1981) are greater than those reported by Lammlein et al. (1974) because the latter authors had not accounted for scattering of seismic waves near the lunar surface or for some instrument effects.) Consequently, it appears that the lunar surface is far more stable than any place on Earth. Lunar base activities such as mining will increase the seismic background, but a preliminary assessment indicates that artificial seismic signals are damped out to below the lunar background within about 10 km of the source of the noise (Taylor 1989).

Tidal forces raise and lower the lunar surface about as much as on Earth, where body tides deflect the ground about 10-20 cm twice each day, but because the Moon is locked into a synchronous orbit, the main tidal bulge on the Moon is a permanent feature. Nevertheless, small tidal deflections stemming from librations do occur, but have much longer periods than on Earth. The tidal flexing of the lunar surface in both horizontal and vertical directions is about 2 mm along the length of a 10-km baseline (Dr. James Williams, personal communication, 1986). The precise amount of motion depends on position on the Moon. Tidal motions must be taken into account when designing arrays of optical telescopes.

Atmosphere

The lunar atmosphere is a collisionless gas. The total nighttime concentration is only 3×10^{-13} mol/m³, or 2×10^5 mol/cm³ (Hoffman et al. 1973). Its total mass is 10^4 kg, about the mass of air in a movie theater on Earth at one bar. This trifling atmosphere allows phenomenal seeing for astronomy; its optical depth (assuming it is composed of oxygen, the most potent absorber of ultraviolet light) is a minuscule 10^{-6} . The virtual lack of air also eliminates engineering problems associated with wind (Johnson 1988), but might add others, such as difficulty in lubricating moving parts. It is also, of course, the prime reason why the lunar surface is assailed by micrometeorites. The small atmosphere is also partly to blame for the high radiation flux.

At night, the Moon's atmosphere is composed chiefly of H₂, He, and other noble gases. These are derived from the solar wind, except for ⁴⁰Ar, which is produced by the decay of ⁴⁰K inside the Moon and then diffuses out (Hoffman et al, 1973). No daytime measurements of gas concentrations were made due to instrument limitations, but enhancements in the levels of CO₂, CO, and CH₄ a short time before sunrise indicates that these gases were being desorbed at sunrise (Hoffman and Hodges 1975). Hodges (1976) calculates that CO₂, CO, and CH₄ probably dominate the daytime atmosphere, but the pressure is still extremely low. They are absent at night because they condense out of the atmosphere onto soil particles.

Surface Temperatures

Surface temperatures change drastically from high noon to dawn on the Moon, presenting a challenge to those designing lunar structures, subject to thermal expansion and contraction. At Apollo 17, for example, the temperature ranged from 384° K to 102° K during the month-long lunar day (Keihm and Langseth 1973). Furthermore, the temperature decreases rapidly at sunset, falling about 5K/hr. These data apply to equatorial regions only. In polar regions, the predawn temperature is about 80° K (Mendell and Low 1970). The temperature in permanently shadowed areas at the poles could be lower. Telescopes must be designed to withstand the large variation in temperature. On the other hand, the cold nighttime temperature will permit cooling of many systems without the use of cryogenics.

The temperature variation is damped out rapidly at depth in the lunar soil (Keihm and Langseth 1973). At a depth of 30 cm the temperature is about 250° K and varies only 2° to 4° K from noon to dawn. This steady temperature might be useful for some purposes, but not as a heat sink because the lunar soil has a very sluggish thermal conductivity (see below).

Magnetic Field

No magnetic field is now being generated inside the Moon, although there was a source of magnetism several billion years ago. It is not known whether this was generated by a dynamo in a metallic core, as on Earth, or by local, transient events such as meteorite impacts. Whatever its source, the lunar magnetic field is much weaker than is Earth's (Dyal et al. 1974). On the surface, the lunar magnetic field strength ranges from 3×10^{-9} to 3.3×10^{-7} T. For comparison, Earth's field at the equator is 3.0×10^{-5} T. The lunar field is too weak to shield the surface from solar flares or

cosmic rays. There is also a field external to the Moon, derived from the solar wind. This ranges from 5×10^{-9} T in the free-streaming solar wind to about 10×10^{-9} T in Earth's geomagnetic tail, in which the Moon resides 4 days during each lunation.

Radiation Environment

Because of the Moon's small magnetic field and nearly absent atmosphere, sunlight and solar and galactic nuclear particles hit its surface unimpeded. The Sun's spectrum peaks in the visible, at about 500 nm, but a significant amount of it, 7 percent, is in the ultraviolet, between 280 and 400 nm (Robinson 1966). Since the solar constant is 1393 W/m^2 at the Earth-Moon distance from the Sun (Coulson 1975), the total ultraviolet flux is 95 W/m^2 .

There are three sources of radiation with different energies and fluxes; see Taylor (1975) for a summary: 1) high energy (1-10 Gev/nucleon) galactic cosmic rays, with fluxes of about $1/\text{cm}^2/\text{s}$ and penetration depths of up to a few m; 2) solar flare particles with energies of 1-100 Mev/nucleon, fluxes up to $100 \text{ cm}^2/\text{s}$, and penetration depths up to 1 cm; 3) solar wind particles, which have much lower energies of about 1000 ev, tiny penetration depths (10^{-8} cm), but high fluxes ($10^8/\text{cm}^2/\text{s}$). These penetration depths refer to the primary particles only. Reactions between them and lunar material cause a cascade of radiation that penetrates deeper (Silberberg et al. 1985), up to a few m. The combination of high flux and energy make solar flare particles the most dangerous to people working on the lunar surface and to electronic devices, such as charge-coupled devices, deployed directly on the surface. Telescope design must take this into account.

Micrometeorite Flux

The lack of a significant atmosphere on the Moon allows even the tiniest particles to impact with their full cosmic velocities, ten to several tens of km/sec. This rain of minute impactors could damage telescope mirrors and other instruments on the lunar surface. Almost all lunar rock samples contain numerous microcraters, commonly called "zap pits," on surfaces that were exposed while on the lunar surface. Studies of lunar rocks (Fechtig et al. 1974) have revealed the average flux of projectiles over the past several hundred million years. However, data from the Surveyor 3 TV camera shroud returned by the Apollo 12 mission and study of Apollo windows (Cour-Palais 1974) indicate that the present flux of particles with $<10^{-7}\text{g}$, which are capable of producing craters up to 10 m across, is about ten times greater than that measured on lunar rocks. Study of louver material from the Solar Max satellite (Barrett et al. 1988) confirm that fluxes are

greater now than during the average of the past several hundred million years. Combining the fluxes of particles $<10^{-7}g$ measured on spacecraft with those $>10^{-7}g$ measured on lunar rocks, Johnson et al. (1989) arrived at the flux estimates in table 2.

It is obvious from these data that microcraters in the 1 to 10 μm size will be common on surfaces exposed at the lunar surface. Even 100 μm craters will not be uncommon, with one produced on each m^2 of surface every other year or so. It appears that sensitive surfaces, such as mirrors on optical telescopes, will have to be protected. The use of collimators will help reduce the flux reaching a telescope mirror. For example, a mirror 1 m across located at the base of a tube 3 m long would receive 5 percent of the values listed in table 2 (Johnson et al. 1989).

Regolith

The lunar regolith, also called the lunar "soil," is a global veneer of debris generated from underlying bedrock by meteorite impacts. It contains rock and mineral fragments and glasses formed by melting of soil, rock, and minerals. It also contains highly porous particles called agglutinates, which are glass-bonded aggregates of rock and mineral fragments. Agglutinates are produced by micrometeorite impacts into the lunar regolith.

Regolith depth ranges from 2 to 30 meters, with most areas in the range 5 to 10 meters. Impacts by micrometeorites have reduced much of the regolith material to a powder. Its mean grain size ranges from 40 to 268 μm and varies chaotically with depth (Heiken 1975). About 20 percent of the regolith is composed of particles smaller than 20 μm . The chemical composition of the regolith reflects the composition of the underlying bedrock, modified by admixture of material excavated from beneath or thrown in by distant impacts

The mechanical properties of lunar regolith samples were measured during the Apollo program, both *in situ* on the lunar surface and on returned samples in laboratories back on Earth (e.g., Mithcell et al. 1972). The bulk density of the regolith is very low, 800 to 1000 kg/m^3 , in the upper few mm, the lunar regolith is more cohesive, 0.1 to 1.0 kN/m^2 , than most terrestrial soils and has an angle of internal friction of 30° to 50°. Agglutinates and shock-damaged rock fragments are weak and break under loads, leading to an increase in soil density (Carrier et al. 1973).

The lunar regolith is an excellent insulator. Its thermal diffusivity at depths of 30 cm is 0.7 to 1.0×10^{-8} m²/s and its thermal conductivity is 0.9 to 1.3×10^{-2} W/m/K (Langseth et al. 1976). This is not surprising considering the high porosity and lack of air. At depths <30 cm, thermal diffusivity is somewhat lower.

The finest grain-size fraction of the regolith poses some problems for astronomical facilities. It can be moved around by rocket launches and landings, surface vehicles, or astronaut suits. This must be controlled by proper procedures (Johnson et al. 1989). A small amount of lunar dust might be transported by charge differences built up by photoconductivity effects. Criswell (1972) described a bright glow photographed by Surveyor 7 and explained the phenomena as levitation of dust grains about 6 μ m in radius. The grains were lifted only 3 to 30 cm above the local horizon, and had a column density of 5 grains/cm². This does not appear to be a significant transport mechanism on the lunar surface, but its effect on the surfaces of telescope mirrors must be evaluated. On the other hand, the reflectivities of the laser reflectors left on the lunar surface apparently has not decreased, so perhaps electrostatic effects also remove dust from some surfaces.

Upper Few Hundred Meters

The upper few hundred m of the Moon have been intensely fragmented by meteorite impacts. In the heavily cratered highlands and regions underlying mare basalt flows, the fragmental region extends for at least a few k. Consequently, it might be difficult to find extensive areas of intact bedrock.

Active seismic experiments (Cooper et al. 1974) indicate that the velocity of compressional waves is about 100 m/s at depths of less than 10 meters, which is in the regolith, and about 300 m/s at depths between 10 and 300 m. These velocities are too slow to correspond to coherent rock, implying that the upper few hundred meters of the lunar surface is rubble (Cooper et al. 1974). Rocks returned from the highlands confirm the fragmental nature of the upper lunar crust. Most are complicated mixtures of other rocks, and many are weakly consolidated. Furthermore, the rims of all craters are by their nature weakly or unconsolidated materials and, therefore, not able to withstand tensional stresses.

A few localities might have intact bedrock, however. Many mare basalt flows, for example, form visible layers of crater walls or, as at the Apollo 15 landing site, in the walls of

sinuous rilles (river-like depressions). Also, extensive sheets of impact-generated melt rocks occur on the floors of many large craters, such as Copernicus, which is 95 km in diameter.

Topography

Fresh lunar craters up to 15 km in diameter have a consistent diameter/depth ratio of 5 (Pike 1974). More specifically, craters <15 km across follow the relation $d=0.196D^{1.010}$; craters >15 km follow the relation $d=1.044 D^{0.301}$ where d is the crater depth and D is the diameter as measured from rim crest to rim crest (Pike 1974). Large craters are much shallower for their diameters than are smaller ones. Crater morphology changes as a crater is eroded by meteorite bombardment, during which a crater becomes wider and shallower, thereby increasing the diameter-to-depth ratio. Thus, even the smoothest areas on the lunar surface are undulating plains, so building precisely horizontal transportation systems might require cut-and-fill operations. No place on the Moon is as flat as the plains of St. Augustin, site of the VLA.

Acknowledgements

Preparation of this paper was supported in part by NASA Grant NAG 9-245.

References

1. Barrett, R.A.; Bernhard, R.P.; McKay, D.S. 1988. Impact holes and impact flux on returned solar max louver material. Lunar and Planetary Science XIX: 39-40.
2. Carrier, W.D. III; Bromwell, L.G.; Martin, R.T. 1973. Behavior of returned lunar soil in vacuum. Joun. Soil Mech. Found. Div., ASCE 99:979-996.
3. Cooper, M.R.; Kovach, R.L.; Watkins, J.S. 1974. Lunar near-surface structure. Rev. Geophys. Space Phys. 12:291-308.
4. Coulson, K.L. 1975. Solar and terrestrial radiations. Academic Press.
5. Cour-Palais, B.G. 1974. The current micrometeoroid flux at the Moon for masses <10⁻⁷ g from the Apollo window and Surveyor 3 TV camera results. Proc. Lunar Sci. Conf. 5th, 2451-2462.

6. Criswell, D. 1972. Lunar dust motion. Proc. Lunar Sci. Conf. 3rd, 2671-2680.
7. Dyal, P.; Parkin, C.W.; Daly, W.D. (1974). Magnetism and the interior of the Moon. Rev. Geophys. Space Phys. 12:568-591.
8. Fechtig, H.; Hartung, J.B.; Nagel, K; Neukum, G. 1974. Lunar microcrater studies, derived meteoroid fluxes, and comparison with satellite-borne experiments. Proc. Lunar Sci. 5th, 2463-2474.
9. Goins, N.R.; Dainty, A.M.; Toksoz, M.N. 1981. Seismic energy release of the Moon. J. Geophys. Res. 86: 378-388.
10. Heikien, G. 1975. Petrology of lunar soils. Rev. Geophys. Space Phys. 13:567-587.
11. Hodges, R.R., Jr. 1976. The escape of solar-wind carbon from the Moon. Proc. Lunar Sci. Conf. 7th, 493-500.
12. Hoffman, J.H.; Hodges, R.R. 1973. Molecular gas species in the lunar atmosphere. The k/Moon 14:159-167.
13. Hoffman, J.H.; Hodges, R.R.; Johnson, F.S. 1973. Lunar atmospheric composition results from Apollo 17. Proc. Lunar Sci. Conf. 4th, 2865-2875.
14. Johnson, F.S. 1971. Lunar atmosphere. Rev. Geophys. Space Phys. 9:813-823.
15. Johnson, S.W. 1988. Engineering for a 21st century lunar observatory. J. Aerospace Eng. 1:35-51.
16. Johnson, S.W.; Taylor, G.J., Wetzel, J.P. 1989. Environmental effects on lunar astronomical observatories. Submitted to Second Symposium on Lunar Bases and Space Activities in the 21st Century.

17. Keihm, S.J.; Langseth, M.G. 1973. Surface brightness temperatures at the Apollo 17 heat flow site: Thermal conductivity of the upper 15 cm of regolith. *Proc. Lunar Sci. Conf*, 4th, 2503-2513.
18. Lammlein, D.R.; Latham, G.V.; Dorman, J.; Nakamura, Y.; Ewing, M. 1974. Lunar seismicity, structure, and tectonics. *Rev. Geophys. Space Phys.* 12:1-21.
19. Langseth, M.G.; Keihm, S.J.; Peters, K. 1976. Revised lunar heat-flow values. *Proc. Lunar Sci. Conf* 7th, 3143-3171.
20. Mendell, W.W.; Low, F.J.; 1970. Low-resolution differential drift scan of the Moon at 22 microns. *J. Geophys. Res.* 75:3319-3324.
21. Mitchell, J.D.; Houston, W.N.; Scott, R.F.; Costes, N.C.; Carrier III, W.D.; Bromwell, L.G. 1972. Mechanical properties of lunar soil; density, porosity, cohesion, and angle of internal friction. *Proc. Lunar Sci. Conf* 3rd, 3235-3253.
22. Nakamura, Y.; Latham, G.V.; Dorman, H.J.; Ibrahim, A.-B.K.; Koyama, J.; Horvath, P. 1979. Shallow moonquakes: depth, distribution and implications as to the present state of the lunar interior. *Proc. Lunar Planet. Sci. Conf* 10th, 2299-2309.
23. Pike, R.J. 1974. Depth/diameter relations of fresh lunar craters: revision from spacecraft data. *Geophys. Res. Lett.* 1:291-294.
24. Robinson, N. 1966. *Solar radiation*. Elsevier Pub. Co., New York.
25. Silberberg, R.; Tsao, C.H.; Adams Jr., J.A. 1985. Radiation transport of cosmic ray nuclei in lunar material and radiation doses. In *Lunar Bases and Space Activities of the 21st Century* (W.W. Mendell, ed.) The Lunar and Planetary Institute, Houston, TX. p. 663-669.
26. Taylor, G.J. 1989. *Astronomy on the Moon: geological considerations*. Submitted to *Second Symposium on Lunar Bases and Space Activities in the 21st Century*.

27. Taylor, S.R. 1975. Lunar Science: A Post-Apollo View. Pergamon Press, New York.
28. Vondrak, R.R. 1974. Creation of an artificial lunar atmosphere. Nature 248:657-659.

Table 1. Comparison of moonquake and earthquake intensities
(From Goins et al. 1981)

	Moon	Earth
Number of events/year	5 shallow (m>2.2)* 500 deep (m>1.6)*	10 ⁴ (m>4)*
Energy release of largest event	2x10 ¹⁰ joule (shallow) 1x10 ⁶ joule (deep)	10 ¹⁹ joule
Magnitude of largest event	4.8 (shallow) 3.0 (deep)	9
Seismic energy release/year	2x10 ¹⁰ joule yr ⁻¹ (shallow) 8x10 ⁶ joule yr ⁻¹ (deep)	10 ¹⁸ joule yr ⁻¹

*m=magnitude

Table 2. Microcrater product rates on the Moon, estimated from data given by Fechtig et al. (1974), Cour-Palais (1974), and Barrett (1988).

Crater diameter (μm)	Craters/m ² /yr
>0.1	300,000
>1	12,000
>10	3,000
>100	0.6
>1000	0.001

ENVIRONMENTAL EFFECTS ON AN OPTICAL-UV-IR SYNTHESIS ARRAY

Stewart W. Johnson¹, G. Jeffrey Taylor², and John P. Wetzel¹

1. BDM International Inc., 1801 Randolph Rd. S.E., Albuquerque, NM 87106
2. Hawaii Institute of Geophysics, University of Hawaii, Honolulu, HI 96822

Abstract

The Moon offers a stable platform with excellent seeing conditions for the Lunar Optical-UV-IR Synthesis Array (LOUISA). Some troublesome aspects of the lunar environment will need to be overcome to realize the full potential of the Moon as an observatory site. Mitigation of negative effects of vacuum, thermal radiation, dust, and micrometeorite impact is feasible with careful engineering and operational planning. Shields against impact, dust, and solar radiation need to be developed. Means of restoring degraded surfaces are probably essential for optical and thermal control surfaces deployed in long-lifetime lunar facilities. Precursor missions should be planned to validate and enhance the understanding of the lunar environment (e.g., dust behavior without and with human presence) and to determine environmental effects on surfaces and components. Precursor missions should generate data useful in establishing keepout zones around observatory facilities where rocket launches and landings, mining, and vehicular traffic could be detrimental to observatory operation.

Introduction

The Moon's environment makes it an excellent place for a Lunar Optical-UV-IR Synthesis Array (LOUISA) (Burns and Mendell 1988). Some of the environmental factors that make the Moon a useful platform for astronomy, however, are not benign and will require special efforts to mitigate their effects. This paper reviews degradation of the components and systems, summarizes results of studies of Surveyor III components exposed to the lunar environment, and presents a preliminary assessment of ways to diminish the damaging effects of the space environment. In the previous paper in this volume, G. Jeffrey Taylor discusses the lunar environment and its effect on optical astronomy. That paper discusses the tenuous atmosphere, the extremes of radiation, micrometeorite flux, dust, and other aspects of the environment. That discussion will not be repeated here and the reader is referred to Taylor's paper.

Degradation of Materials and Systems

The Surveyor III spacecraft landed on the Moon on April 20, 1967. Apollo 12 astronauts Conrad and Bean subsequently visited Surveyor III on the lunar surface in 1969. They retrieved components which they returned to Earth.

Investigations of Surveyor components. Surveyor III components were studied on Earth after these parts had been exposed to the lunar environment for 31 months (roughly 32 lunar days) from April 20, 1967, until November 20, 1969. The following parts were studied (Nickle 1971; Carroll et al. 1972):

- (1) the television camera, which included optics, electronics, cables, and support struts;
- (2) the scoop portion of the soil mechanics surface sampler device (which contained more than six grams of lunar soil);
- (3) a section of polished aluminum tube 19.7 cm long; and
- (4) a section of cabling and painted aluminum tube.

These parts were analyzed for surface changes and characteristics (e.g., adherence of soil particles, sputtering, and UV-induced degradation of thermal control coatings), micrometeorite impacts, radiation damage, particle tracks, and naturally induced radioactivity.

Although the Surveyor III was on the lunar surface for 31 months, it was operated for only two weeks. It experienced 30 1/2 months exposure in a dormant or nonoperating state. Involved were 1500 resistors, capacitors, diodes, and transistors in the camera returned to Earth. Tests after recovery verified the integrity of most parts after 31 months on the Moon (Carroll et al. 1972). A few components failed apparently because of thermal cycling to very low temperatures (e.g., a tantalum capacitor) and as a result of thermal strain (e.g., glass envelopes). Some failures caused a cascade of failures. For example, a failure of the circuit that drove the shuttle was caused by the failure of a transistor that had been degraded in a preflight test; this caused failure of a shuttle solenoid, which in turn caused evaporation of a photoconductor in the vidicon as a result of the shuttle being open (Carroll and Blair 1972).

Solar radiation and effects. The maximum time of exposure of solar radiation during the time the retrieved parts were on the lunar surface is theoretically 10,686 hrs. Shadowing effects limited actual exposure times to considerably less than the theoretical maximum. It was, for example, estimated that the clear optical fiber on the camera had a total exposure of only 4180 h, but that the scoop arm, which had been left fully extended at maximum elevation in 1967 at the Surveyor mission termination, had a total exposure of 9078 h.

As the evaluation of Surveyor III parts was in progress, the tan color of the originally white joint faded due to photobleaching. Photobleaching of induced optical damage can also occur. Therefore, hardware must be sampled and returned carefully to avoid or account for subsequent alteration in the terrestrial laboratory environment (Carroll and Blair, 1972). Although some environment-induced failures occurred, it is clear from the superb results obtained by most experiments of the Apollo Lunar Surface Experiments Packages (ALSEP), that it will be possible to produce systems that will function through many lunations.

Degradation of thermal control coatings. Coatings exposed to the space environment exhibit radiation-induced darkening that increases with time. After 31 months on the Moon, inorganic coatings originally white were tan in appearance. This discoloration was observed to be in a pattern consistent with the amount of irradiation received (Carroll and Blair 1971). Overall discoloration patterns were the result of several effects attributable to solar radiation (e.g., in the ultraviolet), lunar dust, and products of organic outgassing from spacecraft parts (Carroll and Blair 1971). Dust and irradiation played the key roles in altering the appearance (and usefulness) of the surface coatings.

The blue color of the scoop faded to a whitish blue. The surfaces painted with inorganic white degraded from a solar absorptance of 0.2 to 0.38 up to 0.74, depending on orientation. Polished aluminum tubes rose in absorptance from 0.15 to 0.26 (on a "clean" or relatively dust-free surface) to 0.75 where dust was present (Anderson et al. 1971).

The greatest changes in reflectance were for shorter (0.6 to 1.0 μm) as opposed to longer wavelengths (up through 2.0 or 2.4 μm). Both solar radiation and dust were instrumental in decreasing reflectance.

Dust presence. It was estimated that the upper portion of the clear filter, which was positioned over the Surveyor camera lens by remote command at the close of the Surveyor III mission, had 25 percent of its surface area covered by particulate material. This fine-grained lunar soil had a median grain size of 0.8 μm and ranged up to 15 μm in size (Nickle 1971). Dust on the Surveyor mirror was thought to have caused a marked loss of contrast in relayed pictures during the performance of the Surveyor mission (Carroll and Blair 1971). "Lunar material, even in small quantities, can have a significant effect on temperature control and optical performance of hardware on the lunar surface" (Carroll and Blair 1972). Even 10^{-5} to 10^{-4} grams per cm^2 of lunar fines can increase absorbed solar thermal energy for a reflective thermal-control surface by a factor as large as 2 or 3 (Carroll and Blair, 1972). On the other hand, there are no reports of degradation of the laser reflectors left by three Apollo missions.

Sources of dust. There was dust on the returned Surveyor III television camera attributable to one or more of five sources (Carroll and Blair 1971):

(1) the disturbance of the soil during the Surveyor III landing, accentuated by the vernier descent engines that continued thrusting during two rebounds from the lunar surface;

(2) disturbance mechanisms operating on the Moon (e.g., meteoroid impact and electrostatic charging);

(3) Apollo 12 lunar module approach and landing;

(4) operation of the scoop on the Moon; and

(5) retrieval and return to Earth by Apollo 12 astronauts.

The Surveyor III and lunar module (LM) landings were probably the most significant sources of the dust found on the camera. The LM descent engine, which disturbed the dusty surface over the last 1000 ft of its ground track before landing 155 m away, was probably the most significant dust source. Dust was accelerated by the LM rocket plume to velocities in excess of 100 m/s. This accelerated dust literally sandblasted the Surveyor III and removed much discolored paint (Cour-Palais et. al 1972).

Erosion surfaces in the lunar environment. Three processes may be considered in evaluating erosional effects on parts exposed to the lunar environment (Barber et al. 1971):

- (1) sputtering of individual atoms by the solar wind (mainly hydrogen);
- (2) damage from solar flare heavy nuclei (e.g., Fe); and
- (3) micrometeorite impact.

Estimated erosion rates per year from these effects are very small (e.g., 0.4A for sputtering, 0.1 to 0.4A for heavy nuclei, and 1 to 2A for micrometeorite impacts). Micrometeorite impact is probably the most significant mechanism of the three for degradation of telescope optical surfaces, although the effects of sputtering on optical coatings over several years require a restorative capability or replacement.

Results of examinations for micrometeoroid impacts. The television camera shroud, the camera's optical filters, and a piece of aluminum tube were scanned for possible craters resulting from micrometeorite impacts. Magnifications in the range of 25X to 40X and greater were used over substantial portions of the surfaces of these objects as the search for impact craters proceeded (Cour-Palais 1971; Brownlee et al. 1971).

No hypervelocity impact craters were identified in the original studies on the 0.2 m² of the shroud or on the optical filters. Five craters ranging in diameter from 130 to 300 μ m were noted as having a possible hypervelocity impact origin. The many other craters found were thought to have originated as a result of impact of low velocity debris accelerated by the lunar module descent engine plume. However, continued study of the Surveyor materials and of impact pits on lunar rocks led to a reevaluation of the original Surveyor data (Cour-Palais 1974), which indicated that most of the craters on the returned material were hypervelocity impact pits. Nevertheless, damage from low velocity impact was still substantial.

Buvinger (1971) performed an investigation by electron replication microscopy of two sections of the unpainted aluminum tubing. Erosion damage apparently resulted from impact of soil particles during landing maneuvers. Some pits in the approximately 1 mm range had some characteristics of hypervelocity impacts. Solar-wind sputtering apparently had little effect on the

tube and damage by particle impact was apparently by lower velocity particles and limited to a depth no greater than 2 mm.

Mitigation of Degradation

As Carroll et al. (1972) noted, "The need to protect optical elements from dust contamination was obvious during Surveyor III lunar operations in 1967 and was confirmed during analysis of returned hardware. All other optical performance information gained from post-mortem analysis is secondary to this conclusion."

LOUISA design and operation can mitigate and compensate for the potentially detrimental effects of solar radiation, dust accumulation, surface erosion, changes in thermal control coatings, and micrometeorite impacts. We outline below some ideas for blunting the hazardous effects of the lunar environment.

Dust mitigation. Rocket landing and ascent operations can be performed at locations sufficiently far removed from observatory sites to prevent dust erosion and accumulation on optics, antenna, and thermal control surfaces. Shielding against dust driven by rocket plumes may be useful. How great the required keep-out distances or shielding heights against accelerated dust must be depends on the rocket engine and plumes. Keep-out distances may be in excess of 1000 ft based on the extent of LM descent engine sand blasting effects, dust disturbance, and deposition on Surveyor III components.

Harrison "Jack" Schmitt (personal communication, 1988) suggested using optics provided with lens caps that could be remotely controlled to cover and protect optical surfaces before permitting construction and repair teams to approach observatories on the Moon. He noted that the lunar dust is difficult to avoid in astronaut and vehicular traffic on the Moon.

Preserving thermal control surfaces. Some telescope components and other base facilities will be dependent for temperature control on use of thermal control coatings designed to have appropriate values of absorptance and reflectance. If these coatings degrade--as was noted in the case of Surveyor III coatings--temperatures of critical components will deviate from specified values and diminish or negate observatory performance. Protecting coatings by use of layers that intercept UV radiation may help. More stable coatings applied under conditions avoiding contamination may also help.

Use of shields. Shields against micrometeorite impact, dust particles, and solar radiation can be devised to reduce the probability of impact, contamination, or interference by stray light rays. Shields can reduce the probability of impact on optics by reducing the portion of the sky from which impacting particles can originate. Appropriate baffles can prevent the shield from directing stray or scattered light on mirrors or other optics.

Restoration. According to Watson et al. (1988), equipment for restoring coatings on telescope mirrors and thermal control surfaces has been developed and tested on orbit by the USSR. These metal coating operations were performed in space after extensive experimentation in ground-based laboratories to overcome technical difficulties associated with heating, vaporization, and deposition of aluminum. In 1975, cosmonauts Gubarev and Grecho were reported to have recoated the mirror of a solar telescope on the Salyut spacecraft in 1979, 1980, and 1984. Details have not been made available, but results were reported as excellent. These coating-technology experiments suggest that the capability to restore optical and thermal control surfaces degraded by exposure to the space environment may be available for astronomical observatories on the Moon.

It has also been suggested that large mirrors for space use be composed of numerous replaceable segments so that if impact or abrasion causes damage, only the degraded portion need be replaced. Also, mirror surface coatings should be selected that are compatible with cleaning processes and reduce electric charge effects (Bouquet et al. 1988).

Laboratory investigations. Laboratory studies have played and continue to play an important role in estimating the degradation likely when components of space systems are exposed to the space environment. The thermal-vacuum test (Flanagan 1986) will be an essential step in the development and preflight preparations for any observatory components to be deployed on the lunar surface. The systems will be subjected to vacuum and thermal cycling comparable to that found on the Moon to assure that they are capable of operating under very cold and very hot conditions and can accommodate large temperature gradients.

Vacuum chambers with thermal cycling can also include solar simulation which provides an approximation of the solar spectrum. Micrometeorite protection systems can be designed based on available laboratory data (e.g., from light gas guns and Van de Graff Generators) and data

gathered from recovered components (e.g., the Long Duration Exposure Facility (LDEF) and , Solar Max).

Precursor missions. Plans to return to the Moon should include visits to at least one Apollo landing site to ascertain the degradation and changes in selected Apollo materials and components. Six Apollo landings were made between 1969 and 1972, and a wide range of equipment was left on the surface, including the descent stages of the LM, Lunar Roving Vehicles (LRV), and the ALSEPs. Items to be studied include thermal blankets, optics, retroreflectors (for laser ranging), batteries and motors (e.g., on the LRV), communications equipment such as parabolic dishes, various pieces of tankage, and test equipment.

These parts can be studied to ascertain the degradation caused by long-term exposure to micrometeorite bombardment, solar and cosmic radiation, thermal cycling, and vacuum. Areas for study are suggested by the previous experience with Surveyor hardware (Scott and Zuckerman 1971). To be determined are dust and radiation darkening of surfaces, particle impact effects (both primary and secondary), and the effects of long-term thermal cycling in vacuum.

The goals of the visit and study will be to improve the technology for design, fabrication, and test of future lunar astronomical observatories (Johnson 1988), enhance our understanding of processes that occur on the Moon and of the rates at which they operate, and to check the validity of accepted design approaches. Figure 1 demonstrates a generic representation of our need to better understand lunar environmental degradation (Johnson and Wetzel 1988). As shown in the figure, we possess a very limited amount of experience with lunar surface degradation. We must gather additional information about degradation and its effects over a long period of time. For example, revisiting and studying the materials and equipment from the Apollo sites will allow us to acquire information about lunar degradation in the 30-yr time range.

Examination of Apollo materials will be extremely valuable, but will leave many questions unanswered. Additional experiments will be required to fully understand micrometeorite impacts (both primary and secondary), dust levitation, and assorted operational disturbances.

Apollo materials will shed light on the present flux of micrometeorites and shrewd collection of surfaces shielded from direct impact will provide crucial information about the flux of and damage done by secondary projectiles. Nevertheless, an array of micrometeorite detectors,

either passive or active, ought to be deployed on the lunar surface to obtain information on fluxes, masses, velocities, and directions of impacting particles. A device of this sort was emplaced during the Apollo 17 mission (Berg et al. 1973). Furthermore, instruments like this will be developed for use on the Space Station. In addition to supplementing data that will be obtained from study of surfaces of the Apollo spacecraft and instruments, the new generation of lunar surface micrometeorite detectors will provide up-to-date data and a basis for comparison with detectors in low Earth orbit (LEO). This will help establish the natural flux in LEO, a critical parameter to know if we are to accurately monitor the growth of manmade debris in LEO.

As noted earlier, Criswell (1972) suggested that a brightening at the horizon in Surveyor photographs taken shortly after sunset was caused by electrostatic effects. The idea is that electrons are removed by the photoelectric effect when sunlight strikes the surface. This results in a charge imbalance with the uncharged surroundings, causing small grains to be lifted off the ground. It seems prudent to determine the extent to which this process operates and assess whether it will interfere with lunar surface operations. It might, for example, cause micron-sized dust grains to be deposited on telescope mirrors, thereby degrading astronomical observations. An active detector designed to measure that flux and size distribution of low-velocity dust grains could provide the necessary information.

It will also be necessary to monitor disturbances caused by lunar base operations. This includes dust raised by rockets landing and taking off, vehicles moving, and astronauts walking. For example, if astronauts are needed to service telescopes, one must know how much dust could be transferred from their space suits onto a mirror. Perhaps this could be measured by having astronauts approach a low-velocity dust detector. If significant dust were measured, other means of servicing telescopes would have to be devised. Disturbance by the transportation system could also be monitored by an array of dust detectors.

Summary and Conclusions

Although the Moon is an excellent place for astronomy, special efforts will be required to mitigate or compensate for detrimental effects of the lunar environment on LOUISA components. The most troublesome characteristics of the lunar environment are the vacuum (which leads to outgassing), solar and cosmic radiation, micrometeorite impacts, the surface temperature regime, and the ubiquitous dust particles.

Valuable information on degradation of parts and systems in the lunar environment was obtained by retrieval to Earth and careful analysis of Surveyor III components. These components had been on the Moon nearly 32 lunar days from April 1967 to November 1969. Most parts retained their integrity, but a few failed (e.g., because of thermal cycling). Degradation of coatings also occurred, primarily because of ultraviolet radiation and the static and dynamic effects of dust particles on optical and thermal-control surfaces. The dust can cause scattering of light and loss of contrast in optical trains.

Several approaches can be taken to mitigate the negative effects of the lunar environment on astronomical observatory components. First, an effort is needed to better understand and model the degradation mechanisms. This effort should be addressed early in precursor missions to the Moon. Second, operational rules will be necessary to confine activities that generate dust and rocket plumes to zones outside those where astronomical observatories are being used. When it is necessary to approach the observatory sites with vehicles and construction or maintenance teams, precautionary shielding should be activated to protect optics and reduce deposition on thermal-control surfaces. Processes will eventually be needed to clean and restore dusty and impact-damaged surfaces. Fortunately, the lunar environment, although dusty, lacks the hazards in LEO associated with atomic oxygen and orbiting debris, such as chips of paint, from previous missions.

Although the lunar thermal regime offers a severe test of observatory components, careful engineering can control degradation, and the number of cycles to be endured (about one per month) is much fewer than cycles encountered in LEO (about 480 per month). The environment on the lunar surface is conducive to the use of shields and baffles against micrometeorite impact, dust particles, and solar radiation. Experiments in terrestrial laboratories and precursor missions to the Moon are needed to assist in predicting degradation and in reducing its ravaging effects on future lunar astronomical observatories. Restoration processes should be developed to enhance the longevity of observatory components on the Moon. The technology of degradation mitigation that will be developed will apply not only to astronomical observatories, but also to a wide range of lunar base elements. It is prudent to initiate studies of lunar environmental effects early so that beneficial results can be implemented early in the planning of all lunar base facilities.

Acknowledgments

We thank our colleague Jack Burns for encouragement and advice, and T.H. Morgan for useful comments on the paper. Portions of this paper were presented at the Second Symposium on Lunar Bases and Space Activities in the 21st Century. We appreciate support from the BDM Corporation in preparation of this manuscript. This work was supported by NASA Grant NAG 9-245.

References

1. Anderson, D.L.; Cunningham, B.E.; Dahms, R.G.; Morgan, R.G. 1971. X-ray probe, SEM, and optical property analysis of the surface features of Surveyor III materials. Proc. Lunar. Sci. Conf. 2nd, 2753-2765
2. Barber, D.J.; Cowsik, R.; Hutcheon, I.D.; Price, P.B.; Rajan, R.S. 1971. Solar flares, the lunar surface, and gas-rich meteorites. Proc. Lunar Sci. Conf. 2nd, 2705-2714.
3. Berg, O.E.; Richardson, F.F.; Burton, H. 1973. Lunar ejecta and meteorites experiment. Apollo 17 Preliminary Science Report, NASA SP-330, pp. 16-1 to 16-9.
4. Bouquet, F.L.; Maag, C.R.; Heggen, P.M. 1988. Design Considerations for Long-lived Mirrors for Space, NASA Jet Propulsion Laboratory, California.
5. Brownlee, D.; Bucher, W.; Hodge, P. 1971. Micrometeoroid flux from Surveyor glass surfaces. Proc. Lunar Sci. Conf. 2nd, 2781-2790.
6. Buvinger, E.A. 1971. Replication electron microscopy on Surveyor III unpainted aluminum tubing. Proc. Lunar Sci. Conf. 2nd, 2791-2795.
7. Carroll, W.F.; Davis, R.; Goldfine, M.; Jacobs, S.; Jaffee, L.D.; Leger, L.; Milwitzky, B.; Nickle, N.L. 1972. Introduction. In Analysis of Surveyor III Material and Photographs Returned by Apollo 12, NASA, Washington, DC, pp. 15-21.

8. Carroll, W.F.; Blair, P.M. 1972 IV. Spacecraft changes, Part A, lunar dust and radiation darkening of Surveyor III surfaces. In *Analysis of Surveyor III Material and Photographs Returned by Apollo 12*, NASA, Washington, DC, pp. 23-29.
9. Clark, L. 1984. *The Long Duration Exposure Facility (LDEF): Mission 1 Experiments*. NASA SP-473, NASA, Washington, DC.
10. Cour-Palais, B.G. 1974. The current micrometeoroid flux at the moon for masses $<10^{-7}g$ from the Apollo window and Surveyor III TV camera results. *Proc. Lunar Sci. Conf. 5th*, 2451-2462.
11. Cour-Palais, B.G.; Flaherty, R.E.; High, R.W.; Kessler, D.J.; McKay, D.S.; Zook, H.A. 1972. Results of examination of the returned Surveyor III samples for particulate impacts. In *Analysis of Surveyor III Material and Photographs Returned by Apollo 12*. NASA, Washington, DC, pp. 157-158.
12. Economou, T.E.; Turkevich, A.L. 1971. Examination of returned Surveyor III camera visor for alpha radioactivity. *Proc. Lunar Sci. Conf. 2nd*, 2699-2703.
13. Flanagan, G. F. 1986. Hubble Space Telescope ground testing. In *International Test and Evaluation Association 1986 Symposium Proceedings*, Huntsville, AL, pp. 68-90.
14. Johnson, S.W. 1988. Engineering for a 21st century lunar observatory. *J. Aerosp. Engr.* 1:35-51.
15. Johnson, S.W.; Wetzel, J.P. 1988. Advanced technology for a lunar astronomical observatory. In *Engineering, Construction, and Operations in Space*, American Society of Civil Engineers, New York.
16. Nickle, N.L. 1971 Surveyor III material analysis program. *Proc. Lunar Sci. Conf. 2nd*, 2683-2697.
17. *Proceedings of the SMRM Degradation Study Workshop, 1985*. NASA Goddard Space Flight Center, Greenbelt, MD.

18. Scott, R.F.; Zuckerman, K.A. 1971. Examination of returned Surveyor III surface sampler. Proc. Lunar Sci. Conf. 2nd, 2743-2752.
19. Watson, J.K.; Dickinson, D.W.; Raklin, S.I. 1988. Survey of Soviet space welding technology development. In Engineering Construction and Operations in Space (S.W. Johnson and J.P. Wetzel, eds.), American Society of Civil Engineers, New York, NY.
20. Zook, H. 1978. Dust, impact pits, and accreta on lunar rock 12054. Proc. Lunar Planet. Sci. Conf. 9th, 2469-2484.

Precursor missions

Plans to return to the Moon should include visits to at least one Apollo landing site to ascertain the degradation and changes in selected Apollo materials and components. Six Apollo landings were made between 1969 and 1972, and a wide range of equipment was left on the surface, including the descent stages of the LM, Lunar Roving Vehicles (LRV), and the ALSEP. Items to be studied include thermal blankets, optics, retroreflectors (for laser ranging), batteries and motors (e.g., on the LRV), communications equipment such as parabolic dishes, various pieces of tankage, and test equipment.

These parts can be studied to ascertain the degradation caused by long-term exposure to micrometeorite bombardment, solar and cosmic radiation, thermal cycling, and vacuum. Areas for study are suggested by the previous experience with Surveyor hardware (Scott and Zuckerman 1971). To be determined are dust and radiation darkening of surfaces, particle impact effects (both primary and secondary), and the effects of long-term thermal cycling in vacuum.

The goals of the visit and study will be to improve the technology for design, fabrication, and test of future lunar astronomical observatories (Johnson 1988), enhance our understanding of processes that occur on the Moon and of the rates at which they operate, and to check the validity of accepted design approaches. Figure 1 demonstrates a generic representation of our need to better understand lunar environmental degradation (Johnson and Wetzel 1988). As shown in the figure, we possess a very limited amount of experience with lunar surface degradation. We must gather additional information about degradation and its effects over a long period of time. For example, revisiting and studying the materials and equipment from the Apollo sites will allow us to acquire information about lunar degradation in the 30-yr time range.

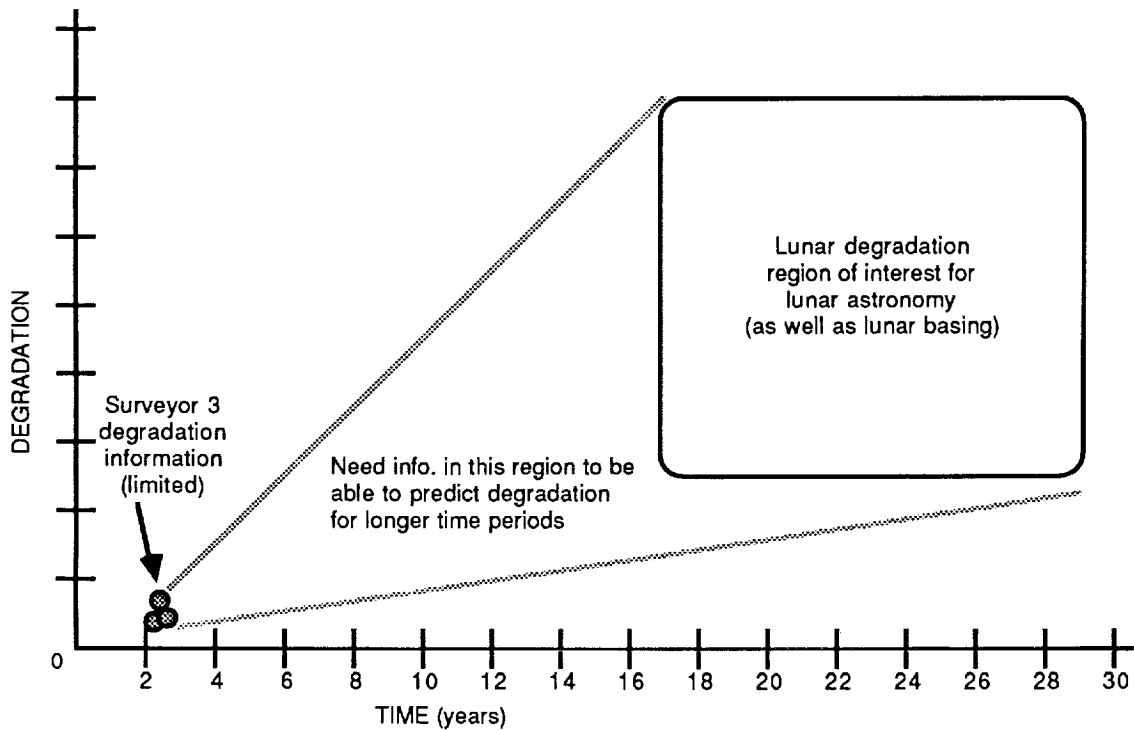

Figure 1. Schematic representation of the information needed to investigate degradation on the lunar surface over a long period of time.

V93-13596

AN OPTICAL VLA ON THE MOON

Bernard F. Burke

Department of Physics 26-335
Massachusetts Institute of Technology
Cambridge, MA 02139

The Moon as an Observing Site

Optical observations on the Earth must cope with the refractive disturbances of the atmosphere, perturbations by the day-to-night thermal cycle, vibrations induced by the wind, and the bending of the telescope by gravity. These all conspire to limit telescope performance. In particular, in trying to improve angular resolution, there seems to be a practical limit of the order of a few tenths of an arc-second for the realizable angular resolution of single-aperture telescopes, largely imposed by the atmosphere, although other structural limitations would appear as limits at one-tenth of an arc-second or so.

Radio astronomers have demonstrated that interferometric aperture-synthesis methods supplant single-aperture methods completely when high angular resolution is desired. The same analysis applies to the optical problem, although the signal-to-noise ratio (SNR) considerations for the radio and optical domains differ. A variety of optical interferometer concepts were discussed at the Cargèse Symposium in 1984 (ESA 1985), and Burke (1985) proposed that a lunar location might be attractive. A more extended treatment of the radio-optical congruence was presented shortly thereafter (Burke 1987). At the Washington Symposium on Science from a Lunar Base (Mendell, 1985; Burke 1985), it was pointed out that the Moon appeared to be a preferred location for optical interferometry in the microarc-second ranges. Shortly thereafter, Johnson examined the engineering questions independently and gave a detailed summary of publications to 1988 on the broader aspects of a lunar observatory (Johnson 1985, 1988). The principal limitation is the cost of establishing an astronomical optical array on the Moon, which could be large if the construction has to be carried out remotely. The concept becomes more realistic if a human-tended lunar base should be established on broader policy grounds by the USA or by the USSR, separately or cooperatively. The construction of a large interferometric optical array then becomes a natural focus of scientific activity at such a base.

The concerns that had been voiced about the lunar environment were treated by Burke (1985a), where it was shown that the apparent problems were unlikely to be substantive. The concerns about lunar dust are largely answered by examining figure 1, which shows the deployment of the lunar laser reflector by the astronauts of Apollo 15. The footprints in the foreground are crisp, showing the cohesiveness of the lunar soil; the laser reflector being deployed in the background has shown no noticeable deterioration over the past 20 years. When the lunar surface is disturbed, dust particles can be kicked up; these travel in ballistic trajectories and generally stick to what they hit. The natural disturbance rate is low, but it is clearly important to avoid needless human activities in the vicinity of lunar-based optical instruments. The seismometer deployed by the Apollo astronauts has given another useful datum: the lunar seismicity is less than 10^{-7} than that of the Earth, and moonquakes will present no problems. Background light from the Moon is less trouble than for a satellite-based system in low-Earth orbit (LEO), and the problem of shielding from sunlight is much easier on the Moon because of the ability to construct suitable, cost-effective shielding structures. Similarly, the thermal environment, with the proper shielding that can be provided on the Moon, is more benign on the Moon than elsewhere.

Constraints from the Scientific Goals

A recent study by the National Research Council National Academy of Sciences (1988) summarized a variety of scientific goals that might be attacked by interferometric means. The problems that might be attacked by optical aperture-synthesis arrays are summarized in figure 2, which shows the various regimes in a distance-linear size plot, in which constant angular resolution shows as a diagonal line. The most interesting problems demand angular resolution considerably better than a milliarc-second, a microarc-second is a marvelous goal, but 10 microarc-seconds would yield an instrument of revolutionary capability. Baselines much greater than 100 m in length (i.e., resolving power better than 1 mas) are not easy to achieve with structures in Earth orbit, but on the Moon, once a lunar base is established, it should be a straightforward project. A resolution of 10 μ as would require a 10-km baseline, which would present no real difficulties. A goal of one mas, requiring a 100-km baseline, is feasible, but the technological problem of relaying the signals over the curved surfaces of the Moon would have to be addressed. One scientific area of great current interest, the study of galactic structure near the central cusp, has not been included in the plot, and is one major problem that could be attacked with a smaller instrument, in the 20-30 m size range.

The problems that might be addressed in the infrared part of the spectrum have not been summarized as fully in the literature, but can be summarized as the study of stellar formation, the production of circumstellar discs, and protoplanetary systems. In general, the problems do not require as high an angular resolution. Nominally, the range of resolution is from 1 mas to 1 arcsec. At $\lambda 10\mu\text{m}$, the work will probably be done best from ground-based facilities, but at wavelengths from $\lambda 2\mu\text{m}$ to $\lambda 10\mu\text{m}$, the space environment is probably superior. This implies interferometer dimensions of the order of 10 m to one km. Although the optical and infrared interferometric arrays may have some degree of mutual compatibility, it is probable that different arrays will be needed.

The prospect has been raised that planetary systems belonging to nearby stars can be imaged directly by optical interferometric arrays (Burke 1986). There are special requirements on the optical quality of the system that go far beyond the requirements of the two general scientific areas discussed above. On the other hand, a maximum baseline of 20 to 30 m is entirely adequate, and there are special demands on optical quality that are more vigorous than for a general purpose array. The likely outcome, therefore, is that a planetary interferometric array would be a separate project, relying upon the same facilities and personnel of a lunar base, but physically distinct.

Elements of the Project

Assume that a lunar base has been established, that a freighter system exists to carry supplies and equipment to the Moon, and that among the residents of the lunar base there will be personnel to assemble, adjust, and deploy equipment. The scientific objectives suggested by figure 2 and by the discussion of the previous section should be addressed in an impressive way by an array with mapping capability in the range of 10 mas to $10\mu\text{as}$. The general specifications of the array are set by these scientific objectives.

The sensitivity of the array should be sufficient to allow the study of 20th magnitude objects; this means that detection alone is not enough, since maps with many resolution elements would be the output in most cases. The point-source sensitivity of an N-element interferometer, in the absence of extraneous noise, is independent of the number of elements provided that the total area remains fixed (Burke 1987). The desired point-noise source sensitivity, therefore, is determined by the magnitude limit, and the total area of the array is set. The number of elements

can then be specified by the interferometric aperture-synthesis requirements, combined with practical economic considerations.

If a 20th-magnitude object, composed of a thousand elements at maximum resolution, is to be mapped, this means that the equivalent point-source sensitivity should be 28th magnitude. An object of 28th magnitude yields a total photon flux of the order of 1.5 photons/m²/sec, and an integration lasting 1 hour would yield 5400 photons to be processed by the correlators for all baselines, for a device of complete efficiency. At fractional bandwidth of 10 percent is probably the best one could hope for, and a throughput of 10 percent is also a reasonable assumption, given the many reflections needed in the optical train. Thus, the detected photon flux for a real system might be of the order of 50 photons/m²/hr.

The SNR (or S/N) of each interferometric pair, for n_{phot} total detected photons detected by an N -element array, will be:

$$(S/N) = (2n_{phot} / N(N + 1))^{1/2} / \sqrt{2} \quad (1)$$

Two photons are required, at a minimum, to estimate fringe amplitude and phase, and during the integration period the instrument itself must be phase-stable. Assuming that the stability condition has been met, an N -element array having a total area $A=NA_0$ (A_0 =area per element) will yield S/N equal to

$$(S/N) = (SAt / (N + 1))^{1/2} = (SA_0t)^{1/2} \quad (2)$$

for a detected photon flux S and integration time t . Hence, a collecting area (per element) of 1 m² will give two photons in an hour per element if there are approximately 27 elements in all. It should be remembered that this is an extreme example: a 1-sigma fringe estimation per pair, with $N = 27$, gives 5-sigma detection of a 28th-magnitude object in an hour, when the individual fringe estimates are coherently added. The scale of the instrument, then, could be on the order of 27 1.6 m telescopes; there are reasons to be conservative in the specifications. The total collecting area would be about 50 m² in this example.

The wavelength range could be anywhere from 0.1 μ m to an infrared wavelength of perhaps 3 μ m. There is reason to limit the long-wavelength limit if optical relaying of the image

to the central processor is used. Diffraction spreads the light in the relay process, and delay lines, especially, become large. An infrared instrument, beyond this range, probably requires different design considerations. Within these general assumptions, one can outline the general specifications of a real system, indicate the alternative choices, and assess the state of the relevant technology.

In succeeding sections, the nature of the telescope elements, the possible array configurations, the possible types of delay lines, the correlator requirements, shipping and deployment, and operational considerations will be discussed.

Weight and cost estimates are highly uncertain at this time, but reasonable projections are not entirely impossible. One factor seems to be especially pressing: the equipment should not be space-rated in the usual way. The reason for placing the facility at a lunar base is to take advantage of human presence to assemble, deploy, and service the equipment. In this respect, there is a fundamental difference between the proposed lunar optical interferometer and an automated space facility of the usual type. Today's space facilities must operate for years without direct human intervention or, if there is human servicing, it is clumsy, expensive, and ad hoc. Lunar gravity may turn out to be an unexpected ally in this respect: it will fix the equipment and give the astronauts firm ground to stand on.

The Telescope Elements

Design and construction of a lunar-based telescope is far easier than on Earth. These stem from two fundamental mechanical restraints, gravitational deflection and columnar failure. These put constraints on the accuracy and sturdiness of a structure, and depend upon Young's modulus, Y , density ρ , the moment of the cross-section I , and the local acceleration of gravity as follows:

$$\text{Deflection of a beam: } \zeta = \gamma(\rho / Y)g L^2 \quad (3)$$

$$\text{Length of Euler buckling: } L_E = I(Y / (gM))^{1/2} \quad (4)$$

The net deflection of a real truss can be much less than the ζ given in equation 3 (γ is a geometrical factor, and is essentially the square of the length-to-depth ratio of the beam). The homology principle, originated by von Hoerner, recognized that gravitational deflection must

occur, but since real 3-D structures are generally redundant, a fixed set of points can continue to lie on a given quadratic surface except for translation and rotation, despite the internal deformations. There are more degrees of freedom than constraints, and physically real homologous solutions usually can be found for real structures. Of course, no real structure is perfect, and for a reduced γ , the above equations will still represent the order of magnitude of the net deflection.

The buckling criterion affects the weight of the supporting structure. In practice, buckling occurs for a smaller length than L_E , but the above accurately represents the dependence upon g for a fixed mass M . The net effect is that a sufficiently robust structure on the Moon will have considerably lighter elements than an Earth-bound telescope. In particular, a daring (but still practical) design for an Earth-bound telescope becomes over-designed when it works under lunar gravity.

It seems prudent, therefore, to design telescope elements that could be tested on Earth, but which are light and compact enough to be assembled by lunar-base personnel. To meet the total area requirements with a reasonable number of telescopes, the reflector diameter would be greater than 1 m, but a diameter of more than 2 m would seem to be cumbersome for easy handling at a lunar base. In this example, a diameter of 1.6 m will be assumed, as a reasonable compromise.

The telescope could be mounted equatorially or in an alt-azimuth configuration; the latter is probably to be preferred, even though field rotation would be needed. The optical design should have a wide field of view, to allow nearby stellar objects to be used as phase references for the system.

The mass of the telescope, the telescope mounting, and the base (which might easily carry the shielding cabin as well) can be scaled to the lunar environment, using the above considerations, from Earth-based experience, although the design of radio telescopes may be more relevant than conventional optical design. Earth-based optical telescopes are massive because they must withstand stresses such as vibration and wind torques that are not present in the lunar environment. Recent developments in mirror design have reduced the mass of optical mirrors dramatically, and this then allows lighter supporting structures. A 1.6 m mirror, made for lunar use, should have a mass of no more than 160 kg (and should, with proper attention to scaling laws,

be even less massive). This reflects into the following mass budget, using modern high-strength composites: The mass seems small

Mirror	160 kg
Telescope	160 kg
Alidade	160 kg
Auxiliary Equipment	<u>100kg</u> /total
	580 kg

compared to Earth-based optical telescopes, but if it were to be tested under Earth gravity but free of air currents, vibration, and thermal gradients, the instrument should have good optical performance. This would become even more favorable under the reduced lunar gravity.

Despite initial fears that the thermal and radiation environment might be hostile, it has become clear that, with proper attention to shielding, the Moon is a relatively benign environment, especially when compared to the Earth-orbited environment. Free-flying telescopes must carry their own light and radiation shields, but there is much greater freedom in designing such structures on the Moon (although the shield still might be preferably mounted as part of the telescope). They can be light, delicate structures, since the wind never blows and they can be constructed *in situ* without having to withstand the stress of launching in the deployed form. Figure 3 shows a conceptual drawing that expresses the philosophy: the eventual shape and scale, of course, could be quite different. The mass of the shield should be no more than 100 kg, and with the telescope mass given above, the total mass of telescope plus shield comes to 680 kg.

Array Configuration

There is a strong scientific imperative to go to an optical array that would yield 1-mas resolution at $\lambda 5000$, but this requires a maximum baseline of 100 km. This is not out of the question, but there is a real problem that would have to be surmounted: the curvature of the Moon's surface. The deviation in elevation from the tangent plane in meters is $R^2/3$, where R is the distance in kilometers, and thus a radius of 50 km from the central station involves a height change of 0.75 km. This is not an insurmountable problem, but if an array of one-tenth that size were planned for, the height difference shrinks to about 7.5 m, a far easier, almost trivial effect

compared to the random relief that will be found. The basic assumption, therefore, will be that the most distant element will be 6 km from the central station. For a VLA-like Wye configuration, this gives a maximum UV spacing of about 11 km, and this can serve as a nominal parameter for the exercise.

There is an alternative configuration that may have advantages: The "Cornwell Array" or "Cornwell Circle." This configuration, derived from studies of the physics of crystals, represents an optimum solution to the problem of placing N antennas within a square of given size, using the entropy of the UV distribution as the figure of merit. The result is antenna placement on a circular locus, but unevenly spaced, with a transfer function that has a quasi-crystalline look in the UV plane. The details can be found in the report of Cornwell (1987).

The choice between the "VLA-Wye" and the "Cornwell Circle" will probably be determined by the balance between the need for several array configurations addressing angular-size ranges and the sufficiency of a single array configuration for most problems of interest. Any finite array is a spatial filter whose transfer function spans a range from the maximum array spacing to a minimum spacing (in angle, from the angle of maximum resolution to a maximum angle), and this implies in turn that angular structures requiring spatial frequencies lower than the minimum array spacing cannot be studied. This, of course, is why the VLA was made variable in extent: For extended objects, the most compact configuration is used; the largest possible array gives the high angular resolution needed for the most compact objects. Intermediate configurations are used for those cases where either a compromise is indicated, or when scaled arrays are desired at different wavelengths. Concentric Cornwell circles could be used, of course, but the Wye gives scaling most easily.

The antennas could be moved on rails (as they are for the VLA) or they could be transported by a wheeled carrier, which would then deposit them on hard points fixed in the lunar soil. The choice would have to depend on the results of a detailed engineering study; for the purposes of this exercise railroad tracks will be adopted as the baseline with the full realization that a wheeled transporter might ultimately be preferred. Tracks have the desirable property that they are kinematically well-defined, and will conduct the telescope to the hard points with a minimum of final adjustment. Because the lunar gravitational acceleration is only one-sixth that of the Earth, the weight on the rails is modest: the conservative mass estimate given earlier would predict a mass of less than 700 kg (i.e., a weight of 64 lb on each of four wheels). This would imply that the rails and ties could have a mass as small as 1.5 kg/m.

The hard points on which the telescope elements would be mounted need not be massive, deeply seated foundations in the lunar surface. The lunar soil is surprisingly resistive to penetration, based on the Apollo experiments and on the Lunakhod penetrator results. A cylinder 10 cm (or even less) in diameter driven 1 m or so into the lunar soil would almost certainly be an adequate post; three of these would easily support the telescope in a competent fashion. These would be placed beforehand at surveyed locations, and the competence of the lunar soil is such that no movement would be expected.

Optical Design

The conceptual design of an optical aperture-synthesis array is fundamentally the same as the radio counterpart. The design might follow the general outline of the VLA (Napier et al. 1983), applying the same general principles outlined in the monograph of Thompson et al. (1986). The physical realization would look quite differently; the optical interferometer described by Colavita (1985) and its extension, as outlined by Shao et al (1986) illustrates the main components. These are (1) the telescope, (2) the telescope guidance system, (3) the optical relay system, (4) the delay line system (and its associated equalization devices), (5) the beam splitters, (6) the correlator, and (7) the data reduction system, which averages the fringe amplitudes and phases. The system must include a fringe stabilization system, using either a field star for a phase reference (this is much easier to accomplish on the Moon because of freedom from atmospheric seeing trouble) or by monitoring the entire optical path with a battery of laser interferometers, as currently practiced by Shao et al. (1986). The major large component that would need the most serious engineering attention is probably the delay-line system, which equalizes the optical path. The optical signals would be relayed as a quasi-planar beam, spreading slightly because of Fresnel diffraction. For the array dimensions that are contemplated, this means that the beam would be about 10 cm in diameter. Each delay line, one per telescope, would have to give a delay equal to the distance from the central station to the most distant station if full delay compensation were to be desired. This means a "throw" of 3 km unless a multiple-pass system is used. Super-reflective optics allow a certain saving, and the throw of the delay line might be some integral submultiple of 3 km; the particular design of delay line would have to follow from an engineering study that is yet to be made. Even a 3-km throw is not beyond reason; a set of carriages mounted on their own tracks, compensated by lasers in the fashion described by Shao et al. could be made to work. It would probably be a multiple-stage affair, with gross stabilization of the main carriage, with a successive set of subcarriages to give the final adjustments.

The delay-line system is not shown in figure 3, because of the great uncertainty in how it should be designed, but one can envisage N tracks radiating from the central station, each with its own laser-controlled mirror. A more elegant solution is to be hoped for, but is not yet in hand.

The Cost

A prefatory remark is in order. If an optical array on the Moon were to be built to conventional flight-test standards, including complete man-rating, it would be an extremely expensive undertaking. The intention, however, would be to send the components to the Moon by whatever freight carrier is used to supply a lunar base. The mirrors would be stacked like a set of dishes (with appropriate spacers to avoid scarring), the mounting and alidade would be shipped in pieces, packed to avoid the mechanical stresses that accompany launch, and the material for the shielding cabins would be packed in bulk. Assembly would be on the Moon by the skilled personnel already there. Individual components such as telescopes and delay lines could be "throwaway" designs. It might be far better to have cheap elements, with a number of spares, than to have complex, elegant, super-reliable elements costing ten or a hundred times more. A cost tradeoff study would determine the best compromise. The fundamental conclusion, however, is that a basic philosophical change from current practice in experiment design will be needed because of the availability of personnel to construct and adjust the equipment and because of the stabilizing influence of lunar gravity.

With this caveat, one can start from the weight budget: These estimates

	<u>Mass</u>	<u>Cost (\$ x 10⁶)</u>
Telescopes and shelters	680 kg	2
Delay-line element	800 kg	4
TOTAL	1480 kg x 27 = 40 tonnes	162
Track (270 km @1.5 kg/m)	400 tonnes	100
Correlator and housing	10	10
Instrumentation	10	100
TOTAL	460 tonnes	372 M

are extremely rough, but they illustrate a few key points. The telescopes themselves are a minor component in the budget. The delay lines are an extremely critical (and uncertain) element. The

biggest contribution is mass to be transported is the track, although it is not a prohibitive element. Nevertheless, wheeled transporters might well be preferred (but they, too, might not be cheap). Bulk transport should be far less expensive than current practice.

A comment is in order concerning the number of elements. The assumed value of N was 27, as for the VLA, but if binary beams splitting is preferred, the number of telescopes would be $2^N + 1$. There would then be 9, 17, or 33 telescope elements, in all probability. If there were only nine elements, the synthesis coverage in the UV plane would be inferior. An array of 17 elements gives excellent coverage, but the 33-element array would give superb UV coverage, especially for snapshots, where full instantaneous sampling of the UV plane is called for. Given the budgetary estimate shown above, the 33-element array might well be preferred. The instantaneous number of interferometer pairs is $N(N + 1) / 2$, and 33 elements can give, therefore, 528 independent samples instantaneously if the array is nonredundant.

In summary, therefore, the cost of an aperture-synthesis optical array, having the ability to give many different configurations, is not an unreasonable project, in scale, to be a major scientific objective of a permanent lunar base. The problems are well defined, and enough research is already in hand to give one confidence in finding workable concepts, ready to go as soon as a lunar base has been established.

References

1. Burke, B.F. 1985a. Astronomical interferometry on the Moon. In *Lunar Bases and Space Activities of the 21st Century*. Mendell, W.W., ed. Lunar and Planetary Institute, Houston, TX, p. 281.
2. Burke, B.F., 1985b. VLBI at optical and radio wavelengths. In *Colloquium on Kilometric Optical Arrays in Space*, October 1984, Cargèse, Corsica, France. ESA Publication SP-226, ESA, Paris, p. 177.
3. Burke, B. F. 1986. Detection of planetary systems and the search for evidence of life. *Nature* 322:340-341.
4. Burke, B.F. 1987. Aperture-synthesis interferometry at optical wavelengths, *SPIE 751 (Reflective Optics)*: 50.

5. Colavita, M.M 1988. Atmospheric limitations of a two-color astrometric interferometer. Ph.D. Thesis, MIT, Electrical Engineering.
6. Cornwell, T.J. 1987. Crystalline antenna arrays. NRAO Millimeter Array Memo No. 38.
7. European Space Agency. 1985. Colloquium on Kilometric Optical Arrays in Space, October 1984, Cargèse, Corsica, France. ESA Publication SP-226, ESA, Paris.
8. Johnson, S.W. 1985. Sitting and constructing telescopes and interferometers on the Moon. Preprint IAF-85-406, 36th Congress and the International Astronautics Federation, Stockholm, Sweden.
9. Johnson, S.W. 1988. Engineering for a 21st century lunar observatory. *J. Aerospace Eng.* 1:1.
10. Mendell, W.W., ed. 1985. Lunar Bases and Activities of the 21st Century. Lunar and Planetary Institute, Houston, TX.
11. National Academy of Sciences/National Research Council. 1988. Space Sciences in the Twenty-First Century. National Academy Press.
12. Napier, P.J.; Thompson, A.R.; Ekers, R.D. 1983. The very large array: design and performance of a modern synthesis radio telescope. *Proc. IEEE*: 1295.
13. Shao, M.; Colavita, M.M.; Staelin, D.H. 1986. The Mark III astrometric interferometer. *Proc. SPIE* 626:250.
14. Thompson, A.R.; Moran, J.M.; Swenson, G.W., Jr. 1966, *Interferometry and Synthesis in Radio Astronomy*. Wiley-Interscience, New York.



Figure 1: Deployment of scientific instruments on the Moon. Note the crisp footprints.

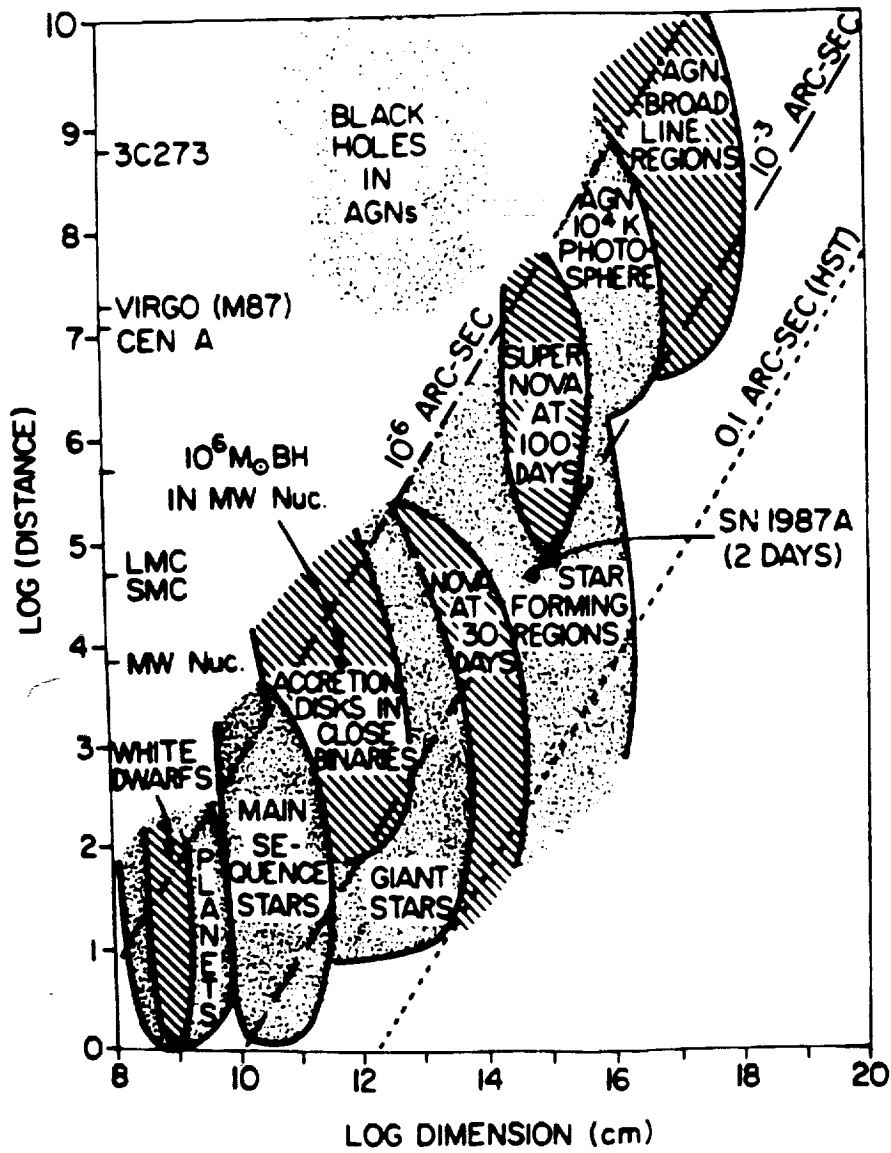

Figure 2: Scientific problems opened by angular resolution improvements. Distance is plotted against characteristic discussion of the object to be studied; constant angular size is given by the diagonal lines in the log-log plot.

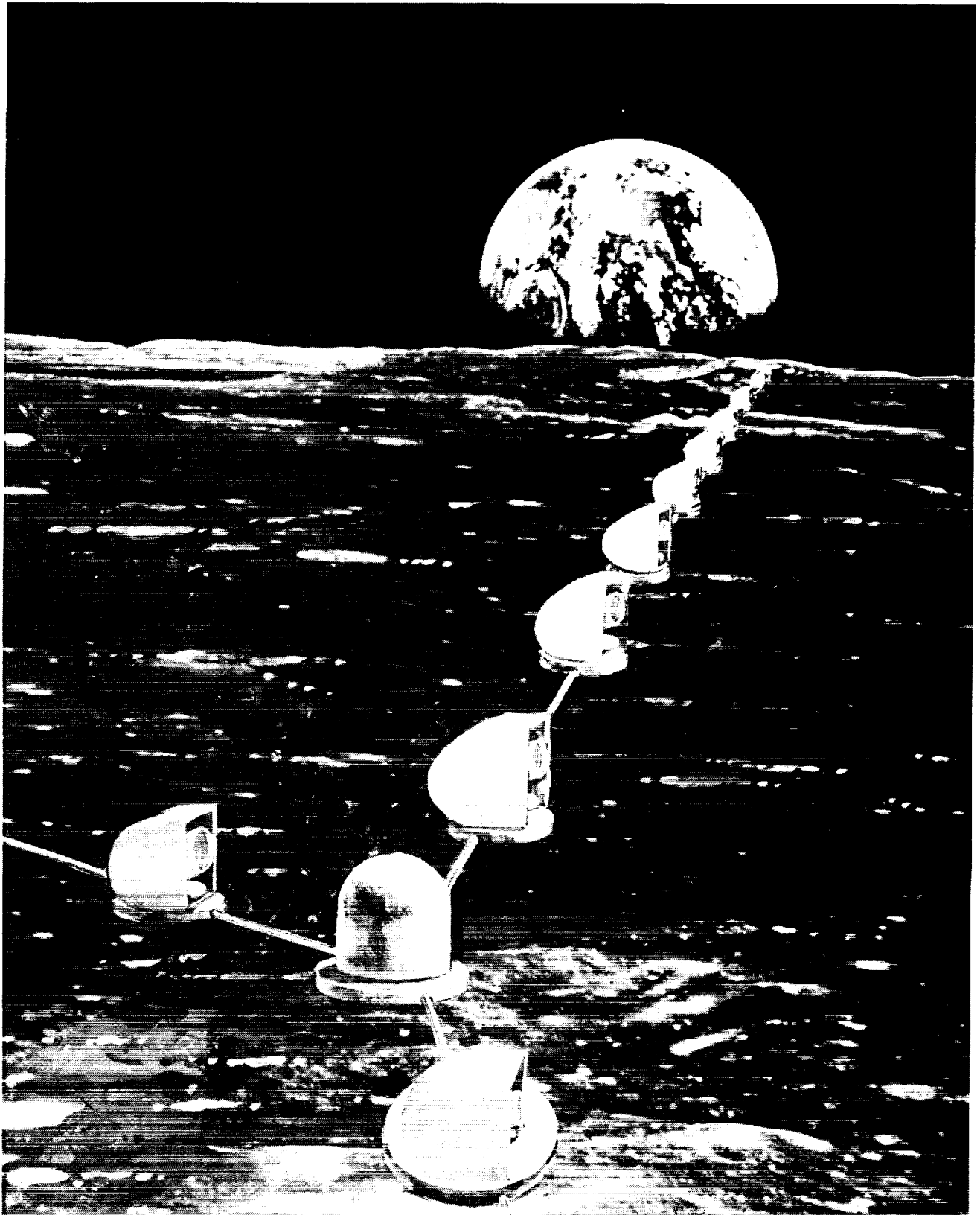

Figure 3: Conceptual rendition of an aperture-synthesis interferometer on the Moon. The delay-line system is not shown, but would consist of tracks radiating from the central processing station, in all likelihood.

APPENDIX: LIMITS ON THE USE OF HETERODYNING
AND AMPLIFICATION IN OPTICAL INTERFEROMETRY

Bernard F. Burke, MIT

The development of optical fibers, lasers, and mixers at optical frequencies has offered the hope that active methods can contribute to optical interferometry. Heterodyning, in particular, looks attractive, even though bandwidths are narrower than one would like at present; one might expect this limitation to lessen as technology develops. That expectation, unfortunately, is not likely to benefit interferometry at optical wavelengths because of the intervention of quantum mechanics and the second law of thermodynamics, as Burke (1985a) pointed out. So much "second quantization" noise is generated that only at infrared frequencies, somewhere in the 10-100 micron range, can one look forward to heterodyning in any realistic sense.

The reason is easily understood. Every amplifier, in the quantum limit, works by stimulated emission, even though this basic truth is not obvious at radio frequencies. This means that there must be spontaneous emission occurring within every amplifier, and Strandberg (1957) showed that this implied a limiting noise temperature, $T_N = h\nu/k$, for any amplifier. Burke (1969) used this result to demonstrate that, if it were not for this quantum noise, the VLBI method would allow one to tell which slit a photon went through before forming an interference pattern, thus violating basic tenants of quantum mechanics. In essence, the second quantization condition $\Delta N \Delta \phi \geq 1$ saves one from paradox. One can state the conclusion simply: any amplifier produces approximately one photon per Hertz of bandwidth. In optical interferometry, one will certainly want bandwidths in the 10^{12} - 10^{14} Hz range, and that implies an intolerable cacophony of noise photons.

Only at infrared frequencies can one tolerate the quantum noise, where the natural noise background may be high and the mixers are not as efficient as one would hope for. The crossover at present is about 10 or 20 microns, but the boundary will shift to longer wavelengths as noise performance improves. One might guess that ultimately a wavelength of about 100 microns will mark the limit of useful amplification and heterodyning in astronomical aperture-synthesis interferometry. At shorter wavelengths, amplification or heterodyning can only degrade the signal-to-noise ratio.

References

1. Strandberg, M.W.P. 1957. Inherent Noise of Quantum-Mechanical Amplifiers, Phys. Rev. 106: 617.
2. Burke, B.F. 1969. Quantum Interference Paradox, Nature 223:389.

REQUIRED TECHNOLOGIES FOR A LUNAR
OPTICAL UV-IR SYNTHESIS ARRAY

Stewart W. Johnson¹

John P. Wetzel²

Abstract

A Lunar Optical UV-IR Synthesis Array (LOUISA) proposed to take advantage of the characteristics of the lunar environment requires appropriate advances in technology. These technologies are in the areas of contamination/interference control, test and evaluation, manufacturing, construction, autonomous operations and maintenance, power and heating/cooling, stable precision structures, optics, parabolic antennas, and communications/control. LOUISA needs to be engineered to operate for long periods with minimal intervention by humans or robots. What is essential for LOUISA operation is enforcement of a systems engineering approach that makes compatible all lunar operations associated with habitation, resource development, and science.

Introduction

LOUISA (figure 1) is one of several types of astronomical observatories that have been proposed to take advantage of the unique nature of the lunar environment. Other observatories include the Very Low Frequency Array (VLFA) for radio astronomy (Douglas and Smith 1985), and the Moon-Earth Radio Interferometer (MERI) (Burns 1985, 1988). With each proposed telescope, there are a myriad of engineering issues to be resolved.

¹ Principal Engineer, Advanced Basing Systems. BDM International, Inc., 1801 Randolph Road S.E., Albuquerque, NM 87106.

² Associate Staff Member, Space Systems. BDM International, Inc.

Advanced Technologies and Critical Engineering Issues

A major difficulty in determining what the critical engineering issues are for LOUISA is that systems for LOUISA are in their early planning stages. Examples of some of the technology development considerations to be addressed for LOUISA are shown in Table 1. The identification of critical engineering issues is somewhat arbitrary predicated on judgment as to observatory design and types of materials and technologies to be used. There will be many significant components such as foundations and supporting structures (which will have stringent requirements for stiffness and thermal stability), thermal control systems, power, communications and control, and data processing and transmission (Johnson 1988).

Table 1. Examples of Technology Development Considerations for LOUISA

LOUISA

- Requirements
- System definition and specifications
- Site selection and characterization
- Control capability (stringent requirements limiting differential settlements, tide compensation)
- Lunar surface layout requires locating and modifying a suitable site
- Dynamic response of lunar soil to movement of telescopes
- Preservation, cleaning, and renewal of optical surfaces and coatings

General Technology Needs

- Automation, telepresence, and robotics for construction, operations, and maintenance
 - Human factors considerations (man-in-the-loop) and realistic artificial intelligence interaction
 - Stiff, stable, light-weight structures from modern composite metal matrix or other selected materials transported from Earth or made on the moon
 - Data gathering, storage, processing and transmission
 - Thermal control, cryocoolers, heat dissipation and heaters as appropriate
 - Power sources to serve lunar outpost requirements
 - Potential applications of superconductivity
 - Mobility on the surface (robots/human)
 - Earth to Moon and return transportation
 - Test and evaluation of system
 - Self-organizing failure characteristics prediction/detection and remote correction
-

Each of these significant components suggests a set of critical engineering issues which can be addressed from the point of view of required technologies to make LOUISA perform in an acceptable way. Table 2 lists the significant new technologies discussed in this paper which will be required for LOUISA.

Table 2. Technologies for LOUISA

Contamination/Interference Control	Manufacturing:
Test and Evaluation	Terrestrial
Construction	In-space
Power and Cooling/Heating	Lunar
Stable Precision Structures	
Optical Systems	Autonomous/Semi-autonomous:
Parabolic Antennas	Deployable
Shielding	Operations
Communications and Control	Maintenance

Contamination/Interference Issues

One of the challenges facing telescope designers and operators is coping with natural and operations-induced sources of contamination and interference (Table 3) on the Moon. Sources of contaminants and interferometers will have implications for all aspects of the lunar astronomical observatory performance (Tables 4 and 5).

Particulates and gases deposited on surfaces can significantly alter optical and thermal properties of surfaces and degrade performance. They can defeat the important attributes of delicate coatings and scatter light, create assembly and erection problems (particulates), and lead to problems in electronics. This paper first looks at some contamination and interference control technologies needed and then deals with selected other technologies for lunar observatories.

Table 3. Some Contamination and Interference Sources and Implications

Fine-grained particulates from the lunar surface - stick to surfaces

Meteoroid impacts - loft debris; cause surface pitting

Gases - stick to surfaces

- Natural
- Induced by operations
 - rocket plumes
 - outgassing from excavations/fill in soil and mining/manufacturing
 - outgassing from suited workers

Radio frequency - interference problem for radio astronomy/communication

Ground shock/vibrations both natural and operations induced - problem for optical interferometers/other instruments

Other:

- Reactor radiation
- Waste heat from power sources

Table 4: Instrument Contamination and Interference and Possible Countermeasures for LOUISA

Possible Contamination/Interference	Possible Countermeasures
Gasses "sticking" to optical surfaces and changing optical properties	Reduction of effluents at source. Technology to purge and renew surfaces
Fine-grained particulates from lunar regolith adhering to optical surfaces and other surfaces	Dust mitigation technologies (reduce operations generating gases); clean-up technologies
Radio frequency interference with broad-band data transmission/reception	Frequency allocation and transmitter standards
Ground shock/vibrations interfering with nanometer precision alignments	Alignment sensing/adjustment in real time; shock/vibration isolation at telescope; shock suppression at origin; keep-out zones

Table 5. Some Recommended Contamination Technology Programs
for Lunar Surface Astronomy

Contamination effects research

- Determination of effects
- Development of acceptable standards

Modeling of the mechanisms of contamination

Critical diagnostics/measurements program for lunar surface contamination

- Material/structural samples deployed to lunar surface and data collected
- Verification/comparison of model and cleaning techniques

Development of contamination prevention and cleaning techniques

Telescopes on the Moon may tend to be surrounded by transient atmospheres resulting from staffed and unstaffed operations in the vicinity (Fernini *et al.* 1990). That there will be a transient gas cloud is evident from the work of investigators (T.H. Morgan, personal communication) interpreting measurements from atmospheric detection instruments on the Apollo Lunar Surface Experiments Package (ALSEP). Under a worst-case scenario, the "cloud" of transient atmosphere could degrade astronomical observations. The cloud density will be dependent on relative rates of contaminant generation and removal. Removal is by collisions with solar wind protons, diverging orbits of particles, expansion into space, decomposition and evaporation, and entrapment or sticking in the lunar soil or regolith.

Particulate and gaseous deposits on critical surfaces of astronomical instruments on the lunar surface may occur as a result of both natural and man-made environments. Deployment and emplacement will involve vehicles and perhaps suited construction workers outgassing water and other byproducts of metabolism and suit functions.

Required power and communication units may be sources of unwanted heat, radiation, and radio frequency interference. Surface operations for emplacement of observatories may involve excavation, compaction, trenching, and fill operations which will accelerate and disperse particulates and liberate gases.

Contamination and Interference Control Technologies

Contamination control is a prime area of concern for virtually any telescope installation. Contamination control technologies required for telescopes to be based on the Moon include protection of precision surfaces and parts through the life cycle including manufacturing, assembly, test and checkout, transportation, landing, erection and deployment, and lunar surface operations and maintenance. Safe techniques to remove contaminants at any stage in this life cycle are needed. Obviously, means to detect and establish the nature of contaminants are required so that the severity of the contamination problems can be monitored and appropriate countermeasures can be taken.

Particular attention is needed to ascertain the implications of long-term lunar surface operations for accumulation on surfaces of contaminants such as fine-grained particulates, products of outgassing of materials, and propulsion products.

There are needs for investigations to improve our understanding of optical and thermal control coatings, their behavior, and interactions with contaminants and radiation environments on the lunar surface. The processes of contamination and contamination removal can be modeled to assist in predictions of the severity of problems developing as a result of various operational scenarios. To develop useful models will require an improved understanding of the physics of surface deposition and better characterization of the lunar environments, both natural and operations-induced. The longer-term goal will be to develop techniques for surface cleaning and coating restoration in situ on the lunar surface.

Johnson, Taylor, and Wetzel (1989) discuss environmental effects on astronomical observatories. They relate to experience with recovered Surveyor III, Solar Max, and other parts exposed to the lunar and orbital environments. The results they present are instructive in formulating future contamination control technologies.

Test and Evaluation Technologies

A methodology and facilities and resources are needed to assure that systems concepts for a lunar astronomical observatory can and will be modeled and tested adequately at various stages of conceptualization, research, development, fabrication, and preparation for launch. The goal is to avoid unpleasant surprises after arrival on the lunar surface. Questions to be resolved by a test

and evaluation process relate to the operational effectiveness and suitability of the observatory systems. Effectiveness questions for test and evaluation are those tied in with performance such as pointing and tracking accuracy and precision, resolution, and image quality. Suitability questions relate to reliability, maintainability, and supportability of the telescope operational systems on the lunar surface. All of the suitability questions are of enormous importance when the logistics line of support is from the Moon to the Earth.

Early involvement of test and evaluation methodologies will start at the telescope system concept level to make adaptation possible to assure testability. Ground-based simulators will be needed to verify interoperability and autonomy of telescopes. Systems for calibration of telescope systems are an important aspect for the prelaunch modeling, test, and evaluation process.

Manufacturing Technologies

Two types of manufacturing capabilities should be pursued to support lunar-based astronomical observatories. One set of capabilities will be on Earth and the other eventually on the Moon. Terrestrial manufacturing of telescopes will be aimed at producing very lightweight, reliable, and packageable components of observatories for shipment to and deployment on the Moon. One example will be composites manufacturing which requires technology development for coatings, joints, fabrication techniques, and complex fixtures for support of steerable dishes and mirrors for radio astronomy and optical astronomy. Parts should be produced so that they are interchangeable where possible (e.g., the struts supporting mirrors and dishes). Optics and electronics suitable for long-term use at a lunar observatory require special care in manufacturing to avoid faults and impurities that lead to subsequent degradation and failure.

In the area of manufacturing, the prime technology issue is producibility. Required for lunar optical array are capabilities to manufacture, assemble, inspect, test, and maintain high quality at reasonable cost. This technology issue becomes of greater importance as more components are required as in the case of an optical array. Ultimately, some components may be manufactured from lunar materials on the Moon--requiring a whole new set of manufacturing technologies.

Construction Technologies

Mobility and transportation with minimal environmental impact are key elements in the deployment of the observatory and its components on the lunar surface. Transportation of components to the lunar surface will, for example, require safe and secure packaging to preserve the integrity and cleanliness of delicate optical and other elements. Deployment and erection sequences must be carefully preplanned so that components match up in spite of temperature variations from component to component and with time. Technologies for deployment should minimize the needs for intervention by construction Workers in space suits. Teleoperated cranes may serve as backup for automated off-loading of components from arriving payload packages. Ways will be needed to prevent the accumulation of fine-grained particulates from the lunar regolith on mating surfaces of contiguous elements of the observatory. Confidence in deployment and erection technologies will be critical in determining the future success of the observatory.

The emplacement of the LOUISA observatory on the Moon will require the capability to maneuver vehicles in remotely controlled (teleoperated) or preprogrammed operational modes. A variety of terrains will be encountered including small and large craters, boulder fields, hills, and valleys.

Autonomous Operations and Maintenance Technologies

Autonomous operation and maintenance of telescope systems on the Moon is a goal that will be difficult to achieve because of the unpredictability of the problems that will be encountered. Allowance should be made for teleoperation and maintenance workers in space suits if unanticipated difficulties arise. Prelaunch test and evaluation efforts on Earth will focus on various aspects of teleoperated operation and maintenance to predict and resolve difficulties before arrival at the Moon.

The vehicle associated with the LOUISA should be able to operate in several different modes as needs dictate change from manual operation to local teleoperation or to remote teleoperation, or perhaps to autonomous operation and hybrid modes. Technical issues with the vehicle design relate to vehicle size and mass, load carrying capacity and range, communications and control, number of wheels (or tracks), manipulator capabilities, power, and methods of coping with the environment (e.g., the soil, rock, and terrain; vacuum; meteoroid impact; radiation; extremes of temperature; and diurnal cycles of solar radiation). The robotic

vehicle system that supports the construction of the LOUISA will be required to support all phases of the effort including transport, layout of the system according to the predetermined plan, emplacement of a central station, and performance of maintenance and repair tasks. The vehicle must have flexibility to meet and cope with unanticipated difficulties such as breakage, unusual terrain, soil variability, and layout adjustments.

The prime power source for the lunar astronomical observatory and associated facilities will be either solar or nuclear or a combination. Solar arrays appear to be suitable if backed by sufficient energy storage capacity (batteries or regenerative fuel cells) to continue operations during the lunar night. There is a strong need for development of regenerative or rechargeable power storage devices, both large and small, for use with solar energy devices to furnish power during the 14 Earth-day lunar night. One option for the next generation battery is a Na/S battery being developed at the Aero Propulsion Laboratory at Wright-Patterson Air Force Base, Ohio (Sovie 1988). Radioisotope thermoelectric generators are also possible power sources although they are inefficient and generate relatively large amounts of heat. Focal plane arrays for optical telescopes on the Moon will need to be cooled. Much technology development is required for cryocoolers to fill this need. One option is the development of an integrated radioisotope-fueled dynamic power generator and cryocooler to cool the focal plane arrays.

Stable Precision Structures Technologies

Technology is required for large, stable, precision structures to support observatory components on the Moon. Geometrically precise structures using advanced materials such as metal matrix composites are needed. These structures can be designed to have the required very low coefficients of thermal expansion.

The supporting structures for optical telescopes on the Moon need attention to isolation from disturbance, structures and controls interaction, and testing issues as portrayed in Table 6.

In operation, LOUISA will involve sequences of structures that are precisely aligned with tracking to high precision. Technologies will be required to measure very accurately and to make adjustments if needed (Table 7).

Optical Systems Technology Drivers

There are many technology drivers for these optics. They include optical coatings that resist delamination, optics that are stress-free after manufacture, and refractive materials that do

not darken or develop color centers. Refractive materials should have low scatter. Adaptive optics will be important for lunar optical telescope applications. Actuator and controls development and power and thermal control for adaptive optics should be pursued.

For mirrors on the lunar surface, active cleaning and contamination control techniques will be needed. Polishing techniques need to be improved; renewable coatings may be required. Materials used for telescopes need to be thermally stable. The appropriate degree of coating hardness against the ultraviolet and X-ray environments of the lunar surface will be needed. The telescope optics will require the necessary vibration isolation.

Table 6. Issues Relating to Large Structures to Support Optics on the Moon

Disturbance Issues

- What are the critical disturbances?
 - Natural - seismic shock, thermal
 - Operations induced - ground shock, vibrations
- What mitigation technologies are applicable?
- How can disturbances be characterized and mitigation approaches formulated?

Structures Issues

- What approaches can be taken to build lightweight, high-stiffness structures optimized for the lunar 1/6 g and extreme thermal environments?
 - Structural parameters - how ascertained?
 - Improved models (computational)
 - Test and instrumentation challenges
 - Optimization
 - Assembly/erection/inspection

Control Issues (for orienting mirrors)

- Control - structure interactions
- Transients and damping in structures optimized for 1/6 g
- Experiments and tests of control mechanics

Testing Issues

- Ground testing on Earth vs. on Moon
 - Scaling of terrestrial structures tests to larger structures at 1/6g
 - Measurements/instrumentation for terrestrial/lunar use
-

Table 7. Technology Development for LOUISA

- Surface accuracies
 - Precise demountable segments
 - Stable frameworks
 - Easily transportable pieces
 - Disassemble/reassemble without loss of accuracy
 - Means for adjustments
 - Mounts with pointing accuracies
 - Foundations in lunar regolith
-

Communication and Control Technologies

There are many requirements on the communication system for the lunar astronomical observatory. Communication satellites in lunar orbit may be needed. At a possible observatory site on the far side of the Moon, communication antennas will be needed for uplink and downlink which are high-gain, lightweight, and have low power consumption. Frequency and bandwidth selection for communications must be compatible with radio astronomy and other operations.

Conclusion

The LOUISA observatory needs to be engineered with technologies that make it possible to perform well for long periods of time with minimal intervention by humans or robots. Better astronomy can be done if contamination and interference (gases, particulates, ground shock, and extraneous RF radiation) resulting from nearby operations can be kept to very low levels by limiting the need for nearby operations. An obvious need is to strive for facilities compatibility in lunar surface operations at various sites by controlling and reducing functions (e.g., proximity of mining operations or rocket launch pads to optical astronomy facilities) that lead to undesirable consequences. This need for compatibility implies the enforcement of a broad-based systems engineering discipline to all lunar engineering, construction, and operations.

Acknowledgments

The support of BDM International, The University of New Mexico, and The National Aeronautics and Space Administration (Grant NAG 9-245) Johnson Space Center in the preparation of this paper is acknowledged. We thank T.H. Morgan for perceptive comments. The

authors are grateful for the advice and support from J. Burns, N. Duric, J. Taylor, W. Mendell, M. Duke, and B. Roberts. Parts of this paper were presented at the Second Symposium on Lunar Bases and Space Activities in the 21st Century. Appreciation is expressed to Jean K. Helmick and Clara P. Peele for preparation of the manuscript.

References

1. Akgul, F.; Gerstle, W.; Johnson, S. 1988. Presentation on a Lunar Steerable Parabolic Dish design for Radio Astronomy, at Space 88 Conference, Albuquerque, NM, August 29-31, 1988.
2. Burke, B.F. 1985. Astronomical interferometry on the Moon. Lunar Bases and Space Activities in the 21st Century, W.W. Mendell, ed., Lunar and Planetary Institute, Houston, TX, pp. 281-291.
3. Burns, J.O. 1985. A Moon-Earth radio interferometer. Lunar Bases and Space Activities in the 21st Century, W.W. Mendell, ed., Lunar and Planetary Institute, Houston, TX, pp. 293-300.
4. Burns, J.O. 1988. 21st century astronomical observatories on the Moon. Engineering, Construction, and Operation in Space, S.W. Johnson and J.B. Wetzel, eds., American Society of Civil Engineers, NY, NY, pp. 1083-1094.
5. Douglas, J.N.; Smith, H.J. 1985. A very low frequency radio astronomy observatory on the Moon. Lunar Bases and Space Activities in the 21st Century, W.W. Mendell, ed. Lunar and Planetary Institute, Houston, TX, pp. 301-306.
6. Fernini, I.; Burns, J.; Taylor, G.; Sulkanen, M.; Duric, N.; Johnson, S. 1990. Dispersal of Gases Generated Near a Lunar Outpost. *Journal of Spacecraft and Rockets*, 27:527-538.
7. Johnson, S.W. 1988. Engineering for a 21st Century Lunar Observatory. *Journal of Aerospace Engineering* 1: 35-51.

8. Johnson, S.W.; Taylor, G.J.; Wetzel J.P. 1989. Environmental Effects on Lunar Astronomical Observatories. Second Symposium on Lunar Bases and Space Activities in the 21st Century, NASA-JSC, Houston, TX.
9. Nickle, N.L. 1971. Surveyor III material analysis program. Proc. 2nd Lunar Sci. Conf., Vol. 3 (Supplement 2, Geochimica et Cosmochimica Acta, J. Geochem. Soc. and Meteorit. Soc.), MIT Press, Boston MA, pp. 2683-2697.
10. Proceedings of the SMRM Degradation Study Workshop 1985. NASA Goddard Space Flight Center, Greenbelt, MD.
11. Scott, R.F.; Zuckerman, K.A. 1971. Examination of the Surveyor III Surface Sampler Scoop Returned by the Apollo 12 Mission. California Institute of Technology, Soil Mechanics Laboratory.
12. Sovie, R.J. 1988. Power Systems for Production, Construction, Life Support and Operations in Space. Engineering, Construction and Operations in Space, S.W. Johnson and J.P. Wetzel, eds., American Society of Civil Engineers, NY, NY, pp. 928-939.
13. The Long Duration Exposure Facility (LDEF): Mission 1 Experiments 1984. Lenwood Clark et al. eds., NASA SP-473, NASA Washington, DC

Additional Sources of Information

1. Burns, J.O.; Mendell, W.W., eds. 1988. Future Astronomical Observatories on the Moon, NASA Conference Publication 2489.
2. Burns, J.; Duric N.; Johnson, S.; Taylor, G.J., eds. 1988. A Lunar Far-Side Very Low Frequency Array, NASA Conference Publication 3039.
3. Johnson, W. 1989. Extraterrestrial Facilities Engineering, invited feature article in 1989 Yearbook, Encyclopedia of Physical Science and Technology, A. Meyers, ed., Academic Press, Inc., San Diego, CA, pp. 91-123.

Figure Caption

Figure 1: Artist concept of 21st Century Lunar Optical UV-IR Synthesis Array (LOUISA). Outer circle of 33 telescopes is a 10 km in diameter; inner circle is 500 m. From the Moon, LOUISA could distinguish (resolve) a dime at the distance of the Earth. Anticipated resolving power is 4,000 to 10,000 times greater than Hubble Space Telescope.

NOTE: For clarity, the individual telescopes are shown larger than they would actually appear on the Moon.



PART V

REPORTS FROM THE WORKING GROUPS

The following three reports represent efforts on the part of our working groups to (1) review the relative merits of Earth-orbit versus Moon-based interferometers, (2) describe the very exciting science to be performed with LOUISA, and (3) produce a strawman design for the array configuration, optics, metrology, control systems, and power. These reports are the results of nearly two days of brainstorming, using the talents of some of the leading experts in both science and engineering. They are intended to represent a starting point from which future, more indepth studies may begin.

WORKING GROUPS

Science
(Chair: N. Duric)

M. Zeilik
H. McAlister
J. Taylor
M. Begelman
S. Prasad
W. Danchi
S. Ridgway
R. Perley
C. Pilcher
S. Kulkarni
C. Ftaclas
I. Fernini
M. Goss

Engineering/Designs
(Chair: S. Johnson)

J.-C. Diels
F. Akgul
T. Cornwell
K.-M. Chua
J. Basart
E. Kibblewhite
A. Labeyrie
C. Jones
L. Lunsford
T. Styczynski
C. Dehainaut
J. Harvey
W. Gerstle
D. Gibson

Space/Moon Tradeoffs
(Chair: D. Nash)

K. Johnston
N. Woolf
M. Shao
H. Smith
M. Scully
P. Bely
R. Brown
M. Nein
D. Ghiglia
J. Asbell-Clarke

REPORT OF THE WORKING GROUP ON SPACE/LUNAR TRADEOFFS

Chair: Doug Nash

Co-Chair: Jeff Taylor

The group discussed the advantages and disadvantages of five locations for an optical/infrared array: low-Earth orbit (LEO), Sun-synchronous Earth-orbit, geosynchronous orbit (GEO), Lagrangian points (L4 and L5), and the lunar surface. The factors affecting an array and our assessments of them are given in table 1 and discussed briefly below. In our discussions, we assumed two axioms:

- 1) Human expansion into space and to the Moon will occur.
- 2) The Space Station will be constructed and operational.

The major conclusion we reached is that baselines of moderate size (>300m) are best done on the Moon and that large baselines (>10 km) can be done only on the Moon.

Three areas needing additional research were identified as follows:

- 1) Studies are needed on methods to steer long-baseline systems in orbit. This involves learning how to control free-flyers. It is not clear how the difficulty of control varies with orbital elevation.

- 2) More work is needed on the internal metrology of array systems, both orbital and lunar-surface systems.

- 3) We need to understand the radiation effects on detectors and electronics and learn how to mitigate them.

Baseline orientation and stability. Baseline stability has two components, internal stability and stability of the orientation of the baseline. The stability of the baseline depends not only on the location of the array (LEO, GEO, etc.) but also on its size. We have also made several assumptions as to the construction of the interferometer array.

For orbiting interferometers, we have assumed that baselines of 300 m or less are single structures and longer baselines in orbit are achieved with multiple spacecraft.

With current technology, distances between optical elements on a large space structure or between spacecraft can be measured with very high precision. The major technical problem is the orientation of the array in inertial space. For short baselines in orbit with the array on one structure, the problem is attitude control. For a multiple-spacecraft array, orientation of the array requires very precise station keeping.

With regard to baseline orientation, two components of the problem are measurement of the orientation and changing the orientation. For changing the orientation, the problem is relatively simple for both the Moon and for single structure interferometric arrays. The problem of measuring the orientation is more fundamental.

As the baseline and, hence, the angular resolution gets higher, the orientation problem becomes more difficult. The basic approach is to use nearby bright stars as guide stars. In this approach, stellar aberration plays a major role. In LEO, orbital motion of the spacecraft can change the apparent position of a star by 5 arcsec. This orbital aberration must be known to very high precision, one tenth to one twentieth of the resolution of this array. Orientation of the optical array is most difficult in LEO and simplest on the Moon.

For short baselines, <30 meters, the angular resolution (3 mas) is sufficiently modest that even LEO placement does not present insurmountable problems. With 300-m arrays, the largest feasible single spacecraft arrays, operation at higher altitude is a necessity. For very long baseline arrays to 10 km, the committee considers station keeping of separate spacecraft to be extremely difficult, except possibly at L5/L4. The technical problems of very long baseline arrays using free-flyers should be studied further to determine feasibility.

The Moon is an excellent platform for any large arrays for two reasons. One is the high degree of seismic stability. The second is the fact that the orbital motion of the Moon is very precisely known.

Thermal stability. Thermal stability will be achieved most easily in an environment with constant or slowly varying solar illumination and constant or slowly varying telescope pointing. In addition, complete protection from the Sun (ambient darkness) will minimize thermal gradients, thus simplifying achievement of stability. LEO is a poor environment owing to rapid transition between day and night. Higher orbits have constant illumination; Sun synchronous,

with an implied preferred viewing angle, may be somewhat better than GEO or the lunar surface. The lunar surface provides a long day and night. The night provides an excellent thermal environment with a surface temperature of about 100°K. A permanently shadowed location (for example, in a polar crater) might offer an ideal, constant environment with low ground-sky differential.

Thermal background. The thermal background disturbs IR measurements when ambient thermal radiation is scattered into the beam. High orbits have the advantage that the background is primarily from the Sun and is most easily baffled. LEO, Sun-synchronous, and the lunar surface have large solid angles of thermal emission, hence pose difficult baffling problems. All free-space configurations have a potential problem with scattering and emission from co-orbiting particles or contamination. The lunar gravity clears such materials from the thin lunar atmosphere. Even during the night the lunar surface has substantial thermal emission at 10 microns and beyond.

Optical background. The optical background disturbs observations by scattering ambient radiation into the beam. Direct sunlight can be baffled well, but extended sources, such as the Earth or the lunar surface in daylight, will be difficult to baffle completely. With adequate baffling, all space-based instruments should be limited by zodiacal and galactic backgrounds.

Radiation environment. Only LEO is relatively free of particle radiation problems. Sun-synchronous orbit (about 1000 km) is getting into the lower (encounters substantial) Van Allen belt, and GEO is in the outer Van Allen belt. GEO and L-5 each experience essentially the full solar wind, solar storm, and cosmic ray flux. The lunar surface is shielded from half of these solar cosmic ray particles.

Duration of darkness. Full dark conditions will almost certainly be required for work on the very faintest sources. This condition is available only for brief intervals (typically half an hour) in LEO, but for intervals of typically 2 weeks on the lunar surfaces.

Debris and micrometeorite risk. The risk to telescopes in space from micrometeorites is roughly the same at all potential locations. However, spacecraft debris is concentrated in LEO, so telescope facilities in LEO are at the greatest risk overall, and relatively simple shielding domes can provide almost complete protection to telescope elements on the Moon.

Maintenance, upgrading, and service. Optical arrays will need maintenance (repair and replacements of damaged parts), service (recharge of cryogenics,) and upgrading (changing detectors to different wavelengths or for greater sensitivity). The ease with which these services can be rendered depends on whether humans or robots have access to the facility. This will be relatively simple for the Moon if there is a lunar base. Telescope arrays in LEO will be accessible from the Space Station, though not all orbits will be reached readily. Access to GEO, Sun-synchronous, and L5 points are not likely to be available in the time frame of at least initial lunar bases.

Complexity of Science Operations. Science operations refer to planning and scheduling the observations that constitute the science program. It involves optimizing the sequence of required pointings based on predicted conditions such as Earth occultations, bright object interference, and engineering factors, such as constraints on spacecraft orientation with respect to the Sun.

Operations in LEO are more complex than for any other space setting. Earth occultations will interrupt most observations one in each 90-min orbit. The radiation environment, particularly encountering the South Atlantic Anomaly, will disrupt observations sporadically. The requirement to communicate through the TDRRS system is also a major operational hurdle for high data rates or if real-time contact with the spacecraft is frequently required.

A factor that applies to all free-flying observatories, but not to the lunar base, is the celestial sphere reference system. This factor makes lunar observatories, which can use the solid surface as a primary reference, fundamentally simpler. Target acquisition and stabilization are trivial once the system is calibrated.

Reconfigurability. Mirrors can be moved along a single structure to improve UV-plane coverage; the maximum baseline is set by the size of the structure. Free flyers can be arbitrarily reconfigured, as with only moderately greater difficulty can elements on the lunar surface.

Number of reflections. The number of optical reflections, an important factor in the overall throughput of the instrument, depends on the optical configuration selected. Fizeau-type interferometers afford the lowest number of reflections (2), but require that the common secondary mirror be some distance away from the primary apertures. This interferometer configuration is feasible only for the shorter baselines or for free-flyer systems. Other optical configurations make use of separate telescopes and delay lines, resulting in five or more optical reflections.

Table 1. Comparison of Locations For Optical/Infrared Array Observatories

Array Characteristic		Array Location				
		LEO	Sun Synchr.	GEO	L5 Points	Lunar Surface
Baseline Stability	0-30m	Mod. Diff.	Mod. Easy	Easy	Easy	Intriniscally Very Good
	30-300m	Very Diff.	Difficult	Mod. Diff.	Easy	
	0.3-10km	Impossible	Impossible	Very Diff.	Easy to Diff.	
	>10km	Impossible	Impossible	Impossible	Diff.	
Thermal Stability		Poor	Very Good	Very Good	Very Good	Polar: Good; Equatorial: Good
Thermal Back-ground		Poor	Very Good	Very Good	Very Good	Lg. Array Poor; Sm. Array Good
Radiation Environment (Cosmic, Solar, Van Allen)		Good	Poor	Very Poor	Very Poor	Poor
Duration of Total Darkness		0.5 Hr.	0	0	0	336 Hr.
Optical Back-ground		Day: Earth Night: Zodiacal	Zodiacal	Zodiacal	Zodiacal	Day: Moon; Night: Zodiacal
Debris And Micro-meteorite Risk		Moderate	Low	Low	Low	Lowest
Mainten-ance, Service And Upgrading		Good	Poor	Poor	Poor	Very Good

Table 1. Comparison of Locations For Optical/Infrared Array Observatories (continued)

Array Characteristic	Array Location				
	LEO	Sun Synchr.	GEO	L5 Points	Lunar Surface
Complexity of Science Operations	Very	Moderate	Moderate	Moderate	Simple
Re-Configurability	Limited	Limited	Limited	Flexible	Flexible
Expandability	Poor	Very Poor	Poor	Good	Excellent
# of Reflections	2 to 5	2 to 5	2 to 5	>2	>5
Science Potential (Angular Resolution)	3 mas 0.3 mas 10 μ as 1 μ as	x x	x x x	x x x x	x x x x
Recommendation (resolution)	3 mas 0.3 mas 10 μ as <1 μ as	√	√	?	√ √ √ √

REPORT OF THE SCIENCE WORKING GROUP:

SCIENCE WITH A LUNAR OPTICAL INTERFEROMETER

Chair: Neb Duric

Co-Chair: Mitch Begelman

Resolution is the single greatest constraining parameter in observational astronomy. The Earth's atmosphere causes an optical image to blur to about 1 arcsec or greater, which is significantly larger than the diffraction limit of most optical telescopes. Interferometric techniques have been developed to overcome atmospheric limitations for both filled-aperture conventional telescopes and for partially filled aperture telescopes, such as the Michelson interferometer or the radio interferometer. Small apertures (from isoplanatic constraints) and the inherent complexities associated with image restoration have limited the use of ground-based optical interferometry to the brightest celestial objects. Current estimates suggest that practical limits to ground-based interferometry will constrain possible resolution to the 1 - 100 mas range. Background seismic noise will prevent any further gains in resolution even if the atmospheric problems are solved.

The Hubble Space Telescope (HST) represents the first step toward space-based optical astronomy, away from the shackles of the Earth's atmosphere. The expected resolution is typically 0.1 arcsec, about an order of magnitude improvement over direct ground based imaging. This improvement is expected to bring out a revolution in optical astronomy as evidenced by the activities of many HST working groups and by the publication of many reports on the potential science windfall. The HST represents an immediate short-term evolution of observational optical astronomy.

In this paper, we wish to focus on a longer time scale of evolution and consider the benefits to astronomy of placing an array of telescopes on the Moon at a time when a permanent base may exist there. The advantages of going to the Moon rather than observing from Earth orbit or one of the Langragian points are based on considerations of background emissions and engineering constraints. These advantages are summarized in the reports of the other two working groups in this workshop. Given the low level of seismic activity on the Moon, the lack of any appreciable atmosphere, and the stability of the lunar soil, it is possible to speak of 10-km interferometer baselines, corresponding to an angular resolution of 10 mas in the middle of the optical spectrum.

Figure 1 summarizes the science made accessible by increasing the angular resolution. Although the HST will open great new areas of research, these represent only the tip of the iceberg. Furthermore, close inspection of figure 1 reveals a natural boundary at 1 mas, beyond which lies a vast amount of unexplored science. This boundary, as mentioned previously, corresponds to a limit on future ground-based imaging. It is the astronomy beyond this limit we wish to discuss here, with the aim of providing the scientific justification needed for establishing an observatory on the Moon.

Basic Working Parameters

It is not the aim of this paper to discuss engineering aspects regarding the feasibility of an optical array capable of microarcsecond scale resolution (this problem is discussed separately in the proceedings). We will assume that the array is sensitive to angular scales in the 1 to 1000 mas range.) The sensitivity is assumed to correspond to a 50-m² collecting area, roughly equal to that of the next generation ground-based telescopes. For reasonable integration times (of order ≈1 hour) we are assuming a working magnitude limit of ≈30^m/pixel. Beyond this limit it is necessary to consider such effects as the zodiacal light and the galactic background, which is outside the scope of this paper. A further assumption, based on the science discussion below, is that the interferometer will nominally operate in the 0.1 μm - 10 μm wavelength range.

As with any interferometer there is a tradeoff between field of view (FOV) and the sensitivity of signal-to-noise ratio (SNR). The FOV can most generally be expressed as

$$FOV = \theta_r \frac{\lambda}{\Delta\lambda},$$

where θ_r is the resolution angle and $\Delta\lambda$ is the bandwidth of the signal being correlated. In the limit where the SNR depends only on the fluctuations of the detected signal (i.e., photon counting case), the SNR can be expressed as

$$SNR = \frac{S}{\sigma_s} = \sqrt{\langle L \rangle},$$

where $\langle L \rangle \propto \tau \Delta\lambda$ is the number of photons integrated over time and bandwidth. The scaling factor is such that $0^m = 10^3$ photons/cm²/s/Å. A comparison between the two equations shows the inverse

relationship between FOV and SNR. For example, a $\Delta\lambda$ of 10^3 \AA (good sensitivity) corresponds to an FOV of 10 mas for θ_R of 10 mas, roughly the same scale size as the diffraction size of a 5-m mirror. The FOV is therefore a major constraint on studies of faint extended objects. To get around this problem, it will be necessary to utilize multichannel correlators.

With these working constraints in mind we now ask ourselves the question, "What science can be done with a lunar optical interferometer?"

The Science

Although there are a number of obvious, specific observations one can immediately list, we have chosen instead to group such observations under more general but important astrophysical questions. We address here seven such questions which can only be directly addressed through mas microarcsecond scale observations. Each problem is discussed in terms of specific relevant observations and how such observations contribute collectively to an understanding of the problem.

What is the nature of the engine that powers active galactic nuclei?

The relevant observations that will best address this question include accretion disk morphologies, location and morphologies of inner jets, and the details of the environment that both fuels the source and constrains the energy outflow. At resolutions of 1 - 10 mas, it is possible to directly image accretion disks in active galactic nuclei (AGNs) such as Centaurus A and M87. In the case of Centaurus A, it is possible to "see" down to the Schwarzschild radius of a 10^8 solar mass black hole. The orientation of the accretion disk and the measurement of its inner and outer dimensions would provide powerful constraints for models of the central engine. A spectral analysis of the immediate environment should provide information on how the accretion disk is fueled. Kinematic information may shed light on the hydrodynamics of the process by which the inflow is converted into collimated outflow. Moreover, observations of the inner jets should further define the nature of this process. The ultraviolet portion of the spectrum is ideal for this kind of study because it provides optimal resolution and avoids self-absorption effects, expected to be important at longer wavelengths.

Detailed imaging of the stellar populations of AGNs will directly address questions regarding starburst galaxies and the Seyfert phenomenon. It may also provide direct evidence for stellar collisions and tidal disruption of stars near supermassive black holes.

What is the physics of collapsed stellar objects?

Observations of interacting binary stars in which one star is a collapsed object (e.g., X-ray binaries) may provide important information on the frequency of white dwarfs, neutron stars, and black holes. It may also shed light on the mass transfer mechanism in such binaries.

For typical X-ray binaries in the galaxy, features on the scale of lengths of a solar radius (10^{11} cm) can be resolved. This should be sufficient to image accretion disks and locate such features as hot spots. Since the mechanisms that trigger novae and type I supernova explosions are thought to involve mass transfer onto compact objects, detailed mapping of the accretion disks and any associated material will be of direct relevance to this problem. Furthermore, the mechanisms by which mass is transferred, whether by Roche lobe overflow or focused stellar winds, can be directly tested by such observations.

What is the relationship between the Sun and other stars, the so called solar-stellar connection?

Observations of surface features, rotation rates, and probing of internal structure are all directly relevant when comparing the Sun with other stars, particularly those of the same spectral class. Solar-type stars can be resolved to distances of ≈ 1 kpc. A systematic study of a large number of such stars may provide important information on the time-line of solar-type activity. This would enable us to infer the history of solar activity and to predict long term secular changes in the Sun. Such information is relevant for determining habitation zones around solar-type stars. In the case of our Sun, information on the evolution of such zones may give us considerable insight into the effects of solar activity on the evolution of life on Earth.

Direct measurements of rotation rates (from motion of surface features) of solar-type stars of different ages will allow us to infer the angular momentum history of our Sun and stars like it. The importance of mass loss and planetary systems in changing the angular momenta of solar-type stars can be addressed through this kind of study.

Stellar seismology utilizes spectroscopic techniques to probe stellar interiors. Such studies would be greatly enhanced for spatially resolved stellar disks and would allow comparisons of stellar structure and the long term evolution of the interiors of solar-type stars.

What environmental factors govern the star formation process?

The shape of the luminosity function of recently formed stars, morphology of protostellar systems, and their local environment are important observations that can define the characteristics of the star-forming environment. Those characteristics that determine the initial mass function (IMF), the formation of single and double stars, and the formation of planetary systems are the ones that need to be identified.

Since star-forming regions (SFRs) are highly obscured, IR observations will be of greatest value. At a resolution of 100 mas (at say $5 \mu\text{m}$) it should be possible to resolve protostars in nearby SFRs such as the Orion nebula. Given sufficient sensitivity, protoplanets of Jupiter's size could be studied individually, thereby shedding considerable light on the process that governs the formation of planetary systems.

Studies of outflows associated with young stellar objects can be made on scales of 0.1 - 1 solar radii, so that a much more detailed picture can be painted of the evolution of stars on their way to the main sequence.

The observations of young clusters in nearby galaxies can be used to infer how the IMF changes with position (and therefore environment) in a galaxy. Such studies can be extended to determine how the star formation process varies from one type of galaxy to another.

Do other planetary systems exist?

This question can be most directly addressed through imaging of the surroundings of nearby stars. However, such imaging is more difficult than it would seem because of dynamic range considerations and the restricted FOVs of optical interferometers operating at high resolution. The Sun and Jupiter, for example, would form a pair that at a distance of 10 pc would have magnitudes of 5 and 26 respectively and be 0.5 seconds of arc apart. The Earth would be 0.1 arcsec away and have a magnitude of 30. The interferometer, operating at a resolution of 10 mas,

would have a field of view of only 10 mas. Unless one knew where to look, planets would be very difficult to find. The use of narrow band filters would solve the FOV problem but decrease the sensitivity of the interferometer. Again, multichannel correlators are desired for this kind of work. The IR may provide an easier way to detect planets because the magnitude difference between a star and Jupiter-like planets is reduced to 18 magnitudes in the N band, for example.

For the nearest stars, Jupiter-like planets could actually be resolved with as many as 100 resolution elements across their disks. Once found, planets could be analyzed spectroscopically to determine atmospheric compositions, crucial in determining habitability.

How do galaxies form?

Dynamic information from the motions of stars and gases can be used to infer the angular momentum distribution in the central and disk regions of galaxies. These distributions provide crucial tests for models of galaxy formation.

By combining proper motion measurements of stars with their radial velocities, it is possible to determine their 3-D velocities as they move in the gravitational potential of a galaxy. Such measurements can be made for the nearest galaxies. For stars near the center of a galaxy, information on the localized mass distributions may lead to the discovery of black hole nuclei in galaxies like M32 and M87. Stellar disk dynamics will allow a comparison of the angular momentum distributions of disks of varying Hubble types. Comparisons among spirals and between spirals and ellipticals may shed light on the manner in which galaxies formed and the differences in initial conditions that led to the currently observed differences.

Similar studies of the internal dynamics of globular clusters can be used to probe their likely formation processes. The dynamics of galactic bulges and the nature of the triaxiality of elliptical galaxies can also provide clues on the formation of galaxies.

Is the Hubble flow uniform and isotropic?

Astrometry on mas scales can, over a time-line of 1 to 10 years, measure proper motions corresponding to velocities of ≈ 100 km/s at a distance of 100 Mpc. This corresponds to 2-4 percent of the Hubble flow velocity. Since proper motions measure velocities at right angles to the line of sight, any such motions would represent a deviation from a purely Hubble flow. A test of this

uniformity at the 2 percent level would be crucial in better understanding the evolution of the universe.

Dynamics of nearby clusters of galaxies can be analyzed in three dimensions to determine whether such clusters are bound. The answer to that question bears directly on the nature of dark matter and the overall geometry and evolution of the universe. Finally, the use of gravitational microlensing as a diagnostic of line of sight material may be useful in mapping the small-scale structures.

REPORT OF THE WORKING DESIGN GROUP

Chair: Stewart Johnson

Co-Chairs: Mike Shao and John Basart

The engineering study group in the LOUISA workshop was responsible for producing a preliminary general design for an optical synthetic aperture telescope on the Moon. This design is intended to be a test case for focusing continuing design studies. The scope of the design included consideration of the array geometry, individual telescopes, metrology, site attributes, and construction. However, no attempt was made to go into further depth in the design than to cover the essential characteristics of the instrument.

The starting point for the array design was the lunar optical array discussed by Burke (1985). His array geometry followed the design and correlation procedure of the 27-element Very Large Array (VLA) radio telescopes near Socorro, New Mexico

Assumptions

Agreeing on a common set of overall characteristics for the lunar synthetic aperture optical array was the first step taken by the design group. These were considered to be minimal assumptions to which the various possibilities of hardware implementation must adhere.

Spectral range: 0.1 to 1 micron

Largest array dimension: 10km

Operating modes: Snapshot and full synthesis

Other assumptions include a previously established lunar base, and unattended computer operation of the instrument. The pre-existence of a lunar base reduces the complexity of telescope construction. Knowledge acquired by lunar inhabitants during construction of the base will be applicable to construction of the observatory. Depending on the facilities located at the base, it may be possible to manufacture part of the instrument on the moon. Human interaction with the instrument is kept to a minimum by recommending only intermittent crew attendance. The maintenance crew can be technicians stationed at the base.

Proposed Array

The array configuration must support a considerable number of baselines to provide images of astronomical sources with minimal sidelobe levels, especially in a snapshot mode. The low rotation rate of the Moon, causing an extensive amount of time for full synthesis observations, makes the snapshot mode a very necessary requirement for the instrument. Hence, reasonable spatial frequency uv domain sampling must occur within an earth day.

Array Geometry

Two of the many possible geometries for the layout of the telescopes for the lunar array are a wye (Y) and a circle. Considerable experience has been gained with a wye by the VLA. In this configuration, an equal number of individual telescopes would be placed on each arm. Movement of portable telescopes can be done linearly along the arms. An advantage of the wye is the ease of extending the length of the baselines along each of three arms. In the VLA, control and data signals are communicated between each antenna and the central control building by way of millimeter wavelength guides buried along the arms. With the lunar telescope, this method of communication is not feasible. Considerable complications arise in passing numerous free-space beams along the arms of the wye. As an alternative to this approach, we have chosen a circular geometry for the array configuration.

Placing optical telescopes in a circle simplifies communications between the telescopes and central control. This is especially important for metrology. The short wavelength of the optical signals places stringent requirements on the system for maintaining phase-stable paths between each telescope and central control. To measure a telescope position, three laser beams at three different wavelengths are beamed from control to the telescope. Mechanical aspects are simplified with the telescopes located circumferentially around the control center. Alternatively, beaming three lasers per telescope along the arm of a wye creates difficulties in reaching the outer telescopes without adding additional elements in the optical path to deviate the light around the inner telescope.

We recommend placing 33 telescopes on a so-called Cornwell reference circle 10 kilometers in diameter. The primary mirror of each telescope would be 1.5 m in diameter, giving a total array collecting area of 50 m². The Cornwell circle arrangement places the telescopes

nonuniformly around a ring in such a way as to give relatively broad coverage of the UV plane. However, it doesn't give sufficient coverage for all astronomical objects. Additional coverage could be obtained by moving the 33 telescopes along radial paths to and from the central control building. But mechanical movement along radial paths involves an expensive transportation system, increases maintenance requirements, needs human interaction, and potentially raises a lot of lunar dust. Consequently, we rejected this approach. Instead, we would place the 33 telescopes on stationary pads and place another nine telescopes on stationary pads on an inner ring with a 500-m diameter. Besides eliminating transportation problems, this approach offers another advantage. Infrared objects generally do not need the resolution of the full array. The inner nine telescopes, providing low resolution, would be constructed to operate efficiently throughout the entire wavelength range of 0.1 to 1 micron, while only a reduced set of the outer telescopes would operate efficiently at IR wavelengths. See Figure 1 in the Johnson and Wetzel paper at the end of Part IV of these proceedings for an artist's sketch of the proposed array configuration.

Individual Telescopes

At this time few requirements are specified for the individual telescopes. Each telescope would have an azimuth/elevation or spherical mount with nearly full sky coverage, and would have an imaging mirror (as opposed to light-gathering ability only). Spherical mounts offer advantages in movement when combined with the metrology system using three laser beams per telescope (Labeyrie, this volume). Spherical mounts avoid the rotation required at alt-az mounts so optical paths are simplified.

Other signal paths between central control and the individual telescopes will be for control and monitoring signals to and from the telescopes and for astronomical signal paths from the telescopes. The control and monitoring signals can be sent via radio, infrared, or optical paths. Astronomical signal paths will be optical.

Array Optics

Optics for the array consist of path delays and a correlator system. Signals from each telescope but one must be delayed on their paths to central control to equalize the path lengths from the arriving wavefront from the celestial source to the correlator. These delays must be adjustable

to account for the change in projected path length as the telescopes track the source while the Moon rotates. The slow rotation of the Moon will simplify the control system for movement of the delays.

The delay can be a movable mirror that doubles the free-space light path back upon itself, thereby lengthening the path. Future technology may allow the light from a telescope to propagate through a variable optical fiber delay on its way to central control. Fiber delays would presumably contain fewer mechanical parts than the movable mirrors operating with free-space paths. A hybrid delay system for one telescope would contain various length sections for optical fibers switched in and out of the light path to form the course delay system. Fine tuning of delays would be accomplished with a movable mirror. This system provides a continuous delay while minimizing physical movement of the mirror.

Central Optics

Upon arrival from the telescopes to central control, the light beams after a correlator system in which all possible pairs of signals from the telescopes are correlated together. The detected correlator outputs, representing the visibility function, constitute the data which is Fourier transformed to get the high resolution image. This "central optics" systems may be quite complex. Each signal must be correlated with every other signal. For an N-telescope system, each signal must be divided into N-1 parts so that each of these parts can be correlated with its counterpart from every other telescope. In this design study, no specifications were selected for the central optics except that it must be designed for interchangeability with alternate instrument systems. Methods of doing spectroscopy and polarimetry were also not considered.

Metrology

The metrology system, as mentioned earlier, consists of three beams at three different wavelengths for each telescope traveling between the telescope and central control. Three positional coordinates can be determined from this. The system must maintain short-term stability of the instrument, while for long-term stability, an astronomic reference source will be observed simultaneously with the program source. To achieve high accuracy, the system must be able to acquire white-light fringes.

Control Systems

Two control systems are necessary to operate the instrument. One system for pointing and tracking the telescope will be tied into the metrology system. All errors need not be eliminated from this control system since errors determined by the metrology system can be accounted for mathematically. Another control system will control the delays and correlator system. This will be tied into the metrology also, since telescope location must be known to calculate the appropriate delay lengths for correlation. Control signals can propagate over light beams from central control to the telescopes, and feedback signals from the telescopes can also propagate over light beams. It may be possible to use the metrology beams to carry control information.

Power System Requirements

Power needs for the lunar optical UV/IR synthesis array (LOUISA) will probably be furnished by a combination of power sources including solar, radioisotope thermoelectric generators (RTGs), and reusable fuel cells. The 33 telescope units on the outer 10-km-diameter circle will each have power needs of about 100 to 500 watts which could be satisfied with a combination of solar and reusable (rechargeable) fuel cells. Batteries would suffer a substantial weight penalty if designed to function through the long lunar night (two Earth weeks). The inner circle 500-m in diameter with nine telescopes and the central station at the system hub can be powered by a linked power distribution system of solar, rechargeable fuel cells, and RTGs. Power needs for the central station with its computer, control system, thermal control, and communications data relay will be of the order of 1000 watts. Shielded power conditioning and control will be required to meet tolerances and operational needs for the range of temperatures and radiation environments at the site.

According to Sovie (private communication), four kinds of space power systems which are under development or in use are:

- Radioisotope thermoelectric generator (RTG)
- Photovoltaic (PV)
- Solar dynamic (SD)
- Nuclear space power systems (e.g., the SP-100)

The RTGs have operated in space in planetary exploration missions for up to 12 years. They generate about 4 watts per kilogram of mass and are usually limited to applications requiring no more than 500 watts but could be extended to 1 to 2 KWe with dynamic energy conversion. Photovoltaic power systems have flown extensively at power levels of a few KWe and below. When batteries are needed to store energy, as in LEO in times of darkness, specific power is 3 to 6 watts per kilogram of mass. SD power systems are still under development. They use a concentrator and a high temperature receiver to heat working fluid and also to heat a thermal energy storage material. The working fluid and the dynamic energy conservation system convert thermal energy to electricity with an efficiency of 20 to 30 percent. A radiator removes waste heat.

In the nuclear reactor space power systems (NRSPS), thermal energy from the reactor goes directly to a static or dynamic energy conversion system. A high temperature radiator removes waste heat. (See table 1.)

The NASA philosophy is that early lunar missions and initial outposts will be powered by advanced solar and/or RTG systems. Later the high capacity power at a lunar base will be provided by nuclear reactor power systems. The nuclear power plant will then run electrolysis units to provide liquid hydrogen and liquid oxygen for fuel cells. Surface transportation would be by vehicles powered by fuel cells. Vehicles powered in this manner will probably be used in constructing the LOUISA.

Photovoltaic solar power with NiH_2 battery energy storage is the state-of-the-art solar power system. Such a system would be prohibitive for use at an initial lunar base because of excessive weight for batteries for the long lunar night.

Advanced solar systems on the Moon will involve photovoltaic or dynamic solar power with reusable fuel cell (RFC) energy storage which reduces the weight penalty by a factor greater than four.

Table 1. Power Systems Characterization
(Specific Mass, kg/kWe)

Type	SOTA solar	Advanced solar	Nuclear					
Description	PV with NiH ₂ battery energy storage	PV or dynamic with RFC energy storage	SP-100 with man-rated shield transported from Earth ¹ and man-rated lunar surface materials ² shield					
			Power level, kWe					
			100		500		2,000	
			Surface ²	Earth ¹	Surface ²	Earth ¹	Surface ²	Earth ¹
			*Lunar surface	33,000	740	40	119	24
*Mars surface	1,190	150	40	119	24	41	12.5	18

* - Specific Mass (kg/kWe)

LOUISA Engineering Test and Evaluation

The engineering test and evaluation of the entire LOUISA system will be a challenging task which must be preceded by technology development, tradeoff studies, component design, and prototype building. The 42 telescopes that compose the array are anticipated to be very similar in configuration to one another such that only about three prototype units will be built and tested as part of a verification system on Earth. Extensive tests of these three prototype units in thermal-vacuum chambers will be required to ascertain their capability to function and operate in vacuum and with variations of temperature comparable to lunar conditions. Tests will be required to ascertain ability to function through the long cold night and survive the high daytime thermal gradients from sunlight areas to shadowed zones.

Software validation and verification for the system will be an extremely important aspect of the development program for LOUISA. Checkout of software will be a very complex task with many different conditions and a complex hierarchy of possible responses in automatic, semiautomatic, and human-operated modes.

The LOUISA will require a substantial research and development effort to bring the elements to sufficient maturity of development for lunar applications. The optics, control systems, metrology, pointing and tracking, thermal control, and other subsystems, metrology, pointing and tracking, thermal control, and other subsystems of the LOUISA system must be integrated and proven to function without human intervention for long periods of time. This degree of autonomy for a complex LOUISA system probably can be achieved only through incorporation of advanced telepresence and artificial intelligence concepts.

Facilities

The lunar surface, with its temperature extremes (over 384°K to 100°K), vacuum, micrometeoroid impacts, and radiation environments, places constraints on the design of facilities for the LOUISA.

The temperature variations day to night on the Moon dictate some aspects of engineering designs. Optical components and support structures should be of materials that have low coefficients of thermal expansion. Needed materials are becoming available with the development of graphite epoxies and metal matrix composite materials. These materials have high elastic moduli for desired stiffness and can be tailored for required low coefficients of thermal expansion.

The vacuum environment will lead to outgassing of organic materials, lubricants, and some coatings. Such outgassing and degradation must be anticipated and dealt with in material selection and engineering design. Outgassing can not only change the properties of outgassing materials in detrimental ways but can also lead to deposits that alter surface properties of sensitive optics and thermal control coatings.

Micrometeoroid impacts will cause pits to form and splatter ejected matter on exposed surfaces. Protection for optics to minimize damage will be required. For example, collimators can be used that restrict the number of degrees of sky to which the optics are exposed and reduce the probability of damage. The means to restore sensitive optics on the Moon should be developed to extend the life of the LOUISA system.

The radiation environments include ultraviolet, solar flare protons, and cosmic ray particles such as ion nuclei. Shielding for humans of the order of 2-2 1/2 m of regolith material will be required at the time of large solar flares. Electronics and computers will need shielding.

Lunar Surface Characteristics

The lunar surface layer is composed of fine-grained particles which, when disturbed, will travel in ballistic trajectories until they impact. The dust is not a problem unless it is disturbed by some mechanism such as vehicular movement, rocket exhaust, or foot traffic. The dust tends to cling to any surface it impacts and thus can constitute a problem in altering surface reflectance.

Electrostatic charges on dust particles may cause particles to be displaced onto nearby objects. More needs to be learned of this phenomenology, particularly with respect to changes in charge as the terminator (boundary between day and night) passes. Vondrack (1974) has suggested the possibility of dust transport as a result of particle-charging which could lead to dust deposits on sensitive surfaces. This phenomenon could be investigated on precursor missions to the lunar surface. Evidence so far suggests that the dust problem is not severe and can be overcome with careful engineering and operations that restrict dust disturbances near the telescopes and other sensitive components. Elements will have to be protected while in transport.

At the Surveyor and Apollo sites, the lunar soil was noted to provide adequate bearing capacity and shear strength for properly engineered observatory foundation elements (Mitchell 1974 and Carrier 1989). Apollo data show that the soil cohesion and angle of internal friction are 0.45 kPa and 40°, respectively, or greater (for 20 cm deep or greater by penetrometer tests). The upper few centimeters of soil are rather loose but at depth, the soil has a high relative density.

The lunar topography is characterized by large numbers of impact craters of sizes ranging to up to several kilometers in diameter and down to microcraters. Some leveling and surface preparation will be necessary for LOUISA to extend to its diameter of 10 km for the outer Cornwell circle and 500 m for the inner circle. Site selection can be made to reduce the amount of excavation, fill, and leveling required as better topographic information becomes available from lunar orbiting surface mappers. Sites favored are on the lunar far side just past the lunar limb so that earthshine is avoided at the telescope site. A site about 5° south of the lunar equator will facilitate observations of the Magellanic Clouds which are of interest to the community.

Soil sampling will be required to depth at the proposed LOUISA sites. In general, the soil relative density increases with depth and the soil tends to be less dense at the rims of relatively recent craters. A tradeoff study is desirable to determine the relative merit of performing more detailed soil engineering property investigations versus using a more robust foundation design suitable for the anticipated range of soil conditions. Soil conditions are the result of numerous and repeated meteoroid impacts which have "gardened" the soil to considerable depth and have made protuberances of competent bedrock highly unlikely. For the foundation design of each telescope of the array, it is anticipated that each of the 42 units of the array will have a mass of 500 km, including mirrors, mirror supports, and enclosures.

The telescope systems and other components that are to perform as a lunar optical ultraviolet infrared synthesis array must be capable of being set up and checked out on a terrestrial site. Such preflight testing is essential to avoid unwelcome surprises on the surface of the Moon.

At each lunar site, some dust stabilization will be desirable to facilitate deployment, calibration, checkout, and post-checkout maintenance. Dust stabilization may be by means of sintering using microwave processing. Foundation elements for the individual telescopes can be either shallow footings extended below the depth of diurnal thermal cycles (about 30 cm) or driven piles to greater depth. Tradeoff studies are needed to permit quantification of the comparisons of these alternatives.

Technology Development

An extensive technology development program is required to make LOUISA a reality in the 21st Century. Tables 2-13 which follow present the significant technology development areas which need emphasis.

References

1. Burke, B.F. 1985. Astronomical interferometry on the Moon. In Lunar Bases and Space Activities in the 21st Century. Mendell, W.W. ed, Lunar and Planetary Institute, Houston, TX, pp. 281-291.

2. Carrier, W.D., III. 1989. *The Lunar Source Book*. Cambridge University Press, New York.
3. Mitchell, J.K. et al. 1974. *Apollo Soil Mechanics Experiment S-200, Final Report, covering work performed under NASA Contract NAS9-11266*, Space Sciences Laboratory, University of California, Berkeley, CA.
4. Vondrak, R.R. 1974. *Creation of an Artificial Lunar Atmosphere*, *Nature* 248:657.

Bibliography

1. Astronomy Survey Committee. 1982. *Astronomy and Astrophysics for the 1980s*. 1. National Academy Press, Washington, DC.
2. Burns, J.O. 1985. *A Moon-Earth radio interferometer*. In *Lunar Bases and Space Activities in the 21st Century*. Mendell, W.W., ed, Lunar and Planetary Institute, Houston, TX, pp. 293-300.
3. Douglas, J.N.; Smith, H.J. 1985. *A very low frequency radio astronomy observatory on the Moon*. In *Lunar Bases and Space Activities in the 21st Century*. Mendell, W.W., ed., Lunar and Planetary Institute, Houston, TX, pp. 301-306.
4. Johnson, S.W. 1988. *Engineering for a 21st Century lunar observatory*. *J. Aerospace Engineering* 1:35.
5. Johnson, S.W.; Wetzel, J.P. 1988. *Advanced technology for a lunar astronomical observatory*. *Engineering, Construction, and Operations in Space*, pp. 1102-1113.
6. Johnson, S.W.; Taylor, G.J.; Wetzel, J.P. 1989. *Environmental effects on lunar astronomical observatories*. In *Lunar Bases and Space Activities in the 21st Century*. vol. 2, in press.

7. Johnson, S.W. 1989. Extraterrestrial facilities engineering, invited feature article in 1989 Yearbook, Encyclopedia of Physical Science and Technology. Academic Press, Inc., pp. 91-123.
8. Johnson, S.W.; Wetzel, J.P. eds. 1988. Engineering, Construction, and Operations in Space. American Society of Civil Engineers, New York. 1349 pages. (This book includes a section on lunar-based and space astronomy organized and chaired by Jack Burns and Neb Duric.)
9. Taylor, G.J. 1989. The lunar environment and its effect of optical astronomy. A Lunar Optical-UV-IR Synthesis Array. NASA CP-3066. U.S. Government Printing Office: Washington, DC, in press.

TABLE 2. FACILITY/HARDWARE LIST

LUNAR FACILITY	33	1.5 M TELESCOPES - OUTER RING-VISIBLE/UV		
	9	1.5 m TELESCOPES - INNER RING - UV/IR		
	1	CENTRAL STATION		
	1	50 M CALIBRATION TOWER		
	2	SATELLITE COMMUNICATION SYSTEM		
	2	LUNAR BASE COMMUNICATION SYSTEM		
	2	LOCAL TRANSMITTING/COMMUNICATION SYSTEM		
	1	SITE STORAGE FACILITY/WITH LANDING SITES		
	1	MAN SAFE HAVEN		
	41	DELAY-LINE SYSTEMS		
	43	SOLAR ARRAY POWER STATIONS WITH BATTERIES (100 WATTS) (17-DAY CAPACITY)		
	LUNAR BASE	1	LTDRSS	
		4	HABITAT/WORKSTATION	
4		LIFE SUPPORT SYSTEM		
AR		LOCAL SITE TRANSPORTATION - HUMAN/CARGO		
AR		TRANS EARTH TRANSPORTATION - HUMAN/CARGO		
2		LUNAR BASE COMMUNICATION SYSTEM		
		TRANS EARTH COMMUNICATION SYSTEM		
1		EXCAVATION AND CONSTRUCTION SYSTEM		
1	TELEOPERATIONS CENTER			
EARTH	2	PROOF OF CONCEPT TELESCOPE UNITS (IR/UV)		
	1	PROOF OF CONCEPT CENTRAL STATION		
	1	THERMAL/VACUUM FACILITY		

	1	TEST INSTRUMENTATION AND CONTROL HARDWARE/SOFTWARE		
	1	IMAGE PROCESSING LAB		
	1	DATA STORAGE/RETRIEVAL SYSTEM		
	1	TRAINING FACILITY	LOUISA SCIENCE CENTER	
		• OPERATIONAL MAINTENANCE		
		• LUNAR ASSEMBLY		
	1	EARTH-BASED COMMUNICATION CENTER		
	1	EXCAVATION AND CONSTRUCTION DEVELOPMENT LAB		
	1	MANUFACTURING DEVELOPMENT LAB		

TABLE 3. TELESCOPE

SHELTER (HOUSING)
PRIMARY MIRROR SYSTEM
SECONDARY MIRROR SYSTEM
ACTIVE METROLOGY SYSTEM (LASER ALIGNMENT CONTROL)
ENVIRONMENTAL CONTROL SYSTEM
POINTING MEASUREMENT AND CONTROL SYSTEM
ALIGNMENT/SURVEY CONTROL SYSTEM
POWER DISTRIBUTION SYSTEM
ELECTRICAL POWER SYSTEM
CONTAMINATION CONTROL SYSTEM
TELESCOPE ASSEMBLY WITH BAFFLE
DATA MANAGEMENT SYSTEM
AUTONOMOUS/SELF-CONTAINED CHECK-OUT-HEALTH STATUS
TELESCOPE MOUNT/FOUNDATIONS/AUTO-LEVELING
COMMUNICATION SYSTEM
DELAY-LINE INTERFACE

TABLE 4. TECHNOLOGY DEVELOPMENT PLAN

OPTICS
SENSORS
ELECTRONICS
MECHANICS
STRUCTURES
CONTROLS SYSTEMS
CALIBRATION
SYSTEMS

TABLE 5. TECHNOLOGY DEVELOPMENT PLAN:
OPTICS

- LUNAR FREQUENCY STABILIZED, LONG, LIFE
 - SOLID STATE SPACE HARDENED DIODE LASER
 - MULTIPLE WAVELENGTH
- OPTICS CONTAMINATION
 - REFURBISHMENT OF OPTICS
 - OPTICAL MATERIALS/COATINGS
 - SHIELDING
- LIGHTWEIGHT MIRROR FABRICATION
 - SUBSTRATE
 - TESTING
 - SURFACING
 - COATINGS
- POLARIZATION
 - COATINGS/MATERIALS
- UV COATINGS FOR LOW POLARIZATION, HI REFLECTIVITY, HARD
- SHIELDING AND BAFFLING STUDIES
- DISPERSIVE AND NONDISPERSIVE SPECTROMETERS
- AREA-SOLID ANGLE PRODUCT - TRANSMITTANCE
- DIFFRACTION ANALYSIS AND DEVELOPMENT OF SOFTWARE OPTIMZATION
- TOOLS
- THERMAL BACKGROUND AND BAFFLE ANALYSIS
- ADAPTIVE OPTICS
- NEW CONCEPT IN MIRROR MATERIALS
 - FOAM CERAMIC GLASS
 - COMPOSITE MIRROR SUBSTRATES
 - REGOLITH MIRRORS
 - GASEOUS MIRRORS
- METROLOGY SYSTEM
- WHITE-LIGHT BEAM-RECOMBINATION

**TABLE 6. TECHNOLOGY DEVELOPMENT PLAN:
SENSORS**

- **RADIATION SHIELDING**
- **LIFETIME**
- **PHOTON-COUNTING AVALANCE DIODE ARRAY
DESIGNS, DEVELOPMENT, AND CHARACTERIZATION**

**TABLE 7. TECHNOLOGY DEVELOPMENT PLAN:
ELECTRONICS**

- **RADIATION HARDENING**
- **THERMAL MANAGEMENT**
- **NEURAL NETWORKS FOR PATTERN-RECOGNITION OF STARFIELDS AND
WHITE-LIGHT FRINGE FINDERS**
- **PREAMPLIFIERS**
- **CONTROL OF ELECTROSTATICS**
- **GROUNDING PLANE**
- **HIGH TE-SUPERCONDUCTIVITY**
- **CORRELATION**

**TABLE 8. TECHNOLOGY DEVELOPMENT PLAN:
MECHANICAL**

- **THERMAL SHIELDING**
- **MATERIALS CHANGE OF PROPERTIES BY RADIATION**
 - **ALUMINUM**
 - **COMPOSITES**
- **BEARINGS AND FLEXIBLE JOINTS ACCURATE AT 10^{-6} RADIANS/SECOND**
- **PHASE DELAY LINE**
- **MAGNETIC LEVITATION BEARINGS, LOW POWER, RELIABLE**
- **MECHANICAL PARTS FABRICATED FROM LUNAR SURFACE MATERIAL**

**TABLE 9. TECHNICAL DEVELOPMENT PLAN:
STRUCTURES**

- "OPTICAL" TRUSS
- REFERENCE TOWER

**TABLE 10. TECHNICAL DEVELOPMENT PLAN:
CONTROL SYSTEMS**

- **STAR AND FRINGE ACQUISITION SCENARIOS, POINTING AND TRACKING**
- **SYSTEM DRIFTS AND THEIR EFFECTS**

**TABLE 11. TECHNOLOGY DEVELOPMENT PLAN:
CALIBRATION**

- **ANGLE ACCURACY - ASTROMETRY**
- **SURVEY-IN INSTRUMENT**
- **EARTH POINT-LASER**
- **UNRESOLVED STARS**

TABLE 12. TECHNOLOGY DEVELOPMENT PLAN:
SYSTEMS

STRAWMAN OPTO-MECHANICAL-ELECTRICAL DESIGN

- SEGMENTED OPTICS
- BASE LINE/APERTURE
- PHASE DELAY LINES/ FIBER OPTICS
- UV PLANE COVERAGE FOR INSTANT SHOT LATITUDE
- METROLOGY SYSTEM
- TELESCOPE MOUNT GEOMETRY
- POLARIZATION
- CALIBRATION AND VERIFICATION OF PERFORMANCE
- GRAVITATIONAL WAVES
- ASTROMETRIC REFERENCES
- BEAM RECOMBINATION
- OPTICS SPECTROMETERS DESIGN APPROACH
- AREA-SOLID ANGLE PRODUCT - TRANSMITTANCE
- THERMAL MANAGEMENT

PART VI

FINALE

Our workshop ended with a panel discussion and review of what we had learned and accomplished during the 3-day workshop. This section attempts to summarize the essence of the panel discussions and our general conclusions about LOUISA. H.J. Smith has provided astute comments on cost, cost-effectiveness, and the challenge of "selling" lunar observatories to our colleagues and the public. We then attempt to summarize the overall results of the workshop. Directions for future work are described in the final pages of these proceedings.

REMARKS AT CLOSING PANEL

Harlan J. Smith

McDonald Observatory, RLM 15.206

University of Texas

Austin, TX 78712

We've spent several days on technical questions concerning lunar interferometry. I'd now like to look at the topic in several broader contexts.

First is the question of cost. No matter how good the Moon is for astronomy of various kinds, it will be hard to justify the tens of billions of dollars needed for a substantial functioning Moon base solely or even primarily for astronomy. I suggest that we need to keep in mind and stress in our public statements that a number of factors support lunar base as the next step beyond Space Station. These include essential space experience, potential resources and commercial payoffs -- even tourism -- in addition to science. The decision to go for a Moon base will then lead to outstanding opportunities for astronomy, in particular for optical/IR interferometry.

Next is the problem of cost-effectiveness. Every astronomical facility considered for the Moon must also squarely face the competition from other possible sites or modes of operation. For interferometry, the possibilities include both ground- and space-based systems. Most of us appear to agree that, at least in the near future, orbiting systems have great promise for short baseline systems (up to tens, possibly someday hundreds, of meters). But we seriously question whether optical/IR baselines of kilometers and tens of kilometers will be very useful in space, primarily because of station-keeping and pointing problems, also the probably excessively high cost of the specialized free-flier elements of such a system. Ground-based optical/IR VLA's would seem to be ruled out almost *prima facie* because of atmospheric problems. However, when we recall that the real cost of a lunar optical/IR VLA is likely to be at least some billions of dollars, I suggest that a careful look be taken at what that amount of money could build on Earth, given a willingness to create substantial adaptive optics systems at the telescopes and tens of kilometers of vacuum tubes to interconnect them--a construction job vaguely on the scale of the Superconducting Supercollider. The Moon might well win on actual cost grounds, not to mention the sex appeal of the project and ability to go to UV wavelengths which will probably remain forever beyond the effective reach of ground-based systems, but the question should be examined.

Finally, there is the problem of getting the message to our colleagues and eventually to the necessary level of funding. Here I am reminded of the experience with Space Telescope (ST). The concept was an early one, floating around in conversations and stories. Lyman Spitzer began to give it reality in 1962 by forming an activist committee (supported, as I recall, by National Academy of Science funds) comprising seven of us, each from a different university. Over the next 3 or 4 years we held a number of meetings at different astronomical centers around the country to discuss and debate the issue, which was strongly questioned if not even attacked at first by some well respected but conservative astronomers. In time a sufficient consensus was built, and around 1967 the committee met to draft a small book which was published by the Academy and which presented the by-then well developed case for ST. All this activity was instrumental in giving the subject high prominence as the principal space initiative to be undertaken (funds permitting) in the definitive report Astronomy and Astrophysics for the 1970s (the Greenstein Report). Almost another decade was needed to get funding started, and more than a decade after that for flight, for a total of nearly 20 years after the first serious push was made. That same scale also feels about right for the lunar optical/IR VLA, in the sense that it may well take a decade or more for the idea to be developed and accepted, still another decade to develop enough lunar experience to be seriously able to design and contemplate building such an instrument there and, finally, another decade to construct it.

But what better time than the present to begin?

SUMMARY AND CONCLUSIONS

Jack O. Burns

Department of Astronomy
New Mexico State University
Las Cruces, NM 88003

A long baseline (1-100 km) Optical/UV/IR interferometer will produce the largest improvement in optical resolution since the original invention of the telescope. A 10-km baseline, for example, will have a resolution of 10 μ arcsec in the middle of the optical band -->4,000 times better than the Hubble Space Telescope.

Short-baseline (<30-m) interferometers have resolutions modest enough that placement in low Earth orbit does not present insurmountable problems. However, for very long baseline arrays (kilometers), station-keeping of separate spacecraft is considered to be extremely difficult except possibly at L4/L5 or the surface of the Moon. If a permanent base is emplaced on the Moon, the lunar surface is the preferred location for such an interferometer. The Moon has a high degree of seismic stability and its orbital motion is precisely known. The Moon is also superior in terms of duration of total darkness (336 hrs), low level of debris, upgrade potential, and array maintenance.

LOUISA will allow astronomers to probe entirely new scales of structure in a variety of astronomical objects. For this reason, LOUISA may be the most scientifically exciting lunar telescope. For example, features on the surface of solar-type stars out to 1 kpc can be imaged, thus allowing the first detailed comparison with our Sun. With the resolving power of LOUISA, extra-solar planets, particularly Jupiter-class planets, can be resolved and mapped in nearby stellar systems. Accretion disks associated with compact objects could be viewed for the first time. Astronomers will be able to study the environmental factors that govern star and galaxy formation, particularly in the near-IR. Finally, LOUISA has the capability of placing strong constraints on the cosmological expansion of the universe.

The preliminary design for LOUISA consists of two concentric circular arrays. The outer array contains 33 telescopes distributed nonuniformly along a circle 10 km in diameter. The inner ring is made up of nine telescopes along a 0.5-km-diameter circle. Such a configuration

produces a good instantaneous synthetic aperture (u-v coverage), and simplifies communication between elements, and does not require any movement of individual telescopes. Individual telescopes would be 1.5 m in diameter for a total collection area of 50 m², with possibly spherical mounts. Optics include delays and a correlator; the delay could consist of a movable mirror or variable-length optical fiber. Two central control systems are needed -- one for pointing and tracking, and the other for control of delays and the correlator.

Future Work

Further evaluation of space-based arrays for comparison with LOUISA is needed. In particular, studies of methods to steer long-baseline systems and control individual element positions are needed.

Substantial new technology development will be required for LOUISA. This is probably the most technically demanding of all the telescopes currently proposed for the lunar surface. In particular, detailed engineering studies of the optics, control systems, correlators, metrology (laser alignment control), pointing and tracking, thermal control, data management, and autonomous operation will be required.

Engineering tests and evaluation of components will be challenging. Individual telescopes will need to be evaluated in vacuum chambers to ascertain their functional capability in the lunar environment. Then, integration of the telescopes and correlators must be considered. This might best be accomplished on the lunar surface beginning with a simple two-element interferometer, then growing when technological barriers are overcome.

LOUISA must be capable of coping with the harsh lunar environment. The effects of dust, micrometeoroids, cosmic radiation, and structural degradation must be considered.

The power requirements are fairly substantial, about 25 kw of total electrical power will be needed during both lunar day and night. Generation and storage of this power at the LOUISA must be addressed.

REPORT DOCUMENTATION PAGE

Form Approved
OMB No. 0704-0188

Public reporting burden for this collection of information is estimated to average 1 hour per response, including the time for reviewing instructions, searching existing data sources, gathering and maintaining the data needed, and completing and reviewing the collection of information. Send comments regarding this burden estimate or any other aspect of this collection of information, including suggestions for reducing this burden, to Washington Headquarters Services, Directorate for Information Operations and Reports, 1215 Jefferson Davis Highway, Suite 1204, Arlington, VA 22202-4302, and to the Office of Management and Budget, Paperwork Reduction Project (0704-0188), Washington, DC 20503.

1. AGENCY USE ONLY (Leave blank)		2. REPORT DATE November 1992	3. REPORT TYPE AND DATES COVERED Conference Publication	
4. TITLE AND SUBTITLE A LUNAR OPTICAL-ULTRAVIOLET-INFRARED SYNTHESIS ARRAY (LOUISA)			5. FUNDING NUMBERS	
6. AUTHOR(S) JACK O. BURNS, STEWART W. JOHNSON, AND NEBOJSA DURIC, EDITORS				
7. PERFORMING ORGANIZATION NAME(S) AND ADDRESS(ES) THE UNIVERSITY OF NEW MEXICO INSTITUTE FOR ASTROPHYSICS DEPT OF PHYSICS AND ASTRONOMY ALBUQUERQUE, NEW MEXICO 87131			8. PERFORMING ORGANIZATION REPORT NUMBER	
9. SPONSORING / MONITORING AGENCY NAME(S) AND ADDRESS(ES) NATIONAL AERONAUTICS AND SPACE ADMINISTRATION WASHINGTON, DC			10. SPONSORING / MONITORING AGENCY REPORT NUMBER NASA CP-3066	
11. SUPPLEMENTARY NOTES JACK O. BURNS, DEPT OF ASTRONOMY, NEW MEXICO STATE UNIV., LAS CRUCES, NEW MEXICO 98003; STEWART JOHNSON, THE BDM CORPORATION, 1801 RANDOLPH DR. SE, ALBUQUERQUE, NEW MEXICO 87106; NEBOJSA DURIC, INSTITUTE FOR ASTROPHYSICS, THE UNIVERSITY OF NEW MEXICO, ALBUQUERQUE, NEW MEXICO 87131.				
12a. DISTRIBUTION AVAILABILITY STATEMENT UNCLASSIFIED - UNLIMITED SUBJECT CATEGORY 89			12b. DISTRIBUTION CODE	
13. ABSTRACT (Maximum 200 words) THIS DOCUMENT CONTAINS PAPERS PRESENTED AT A WORKSHOP HELD TO CONSIDER OPTICAL-ULTRAVIOLET-INFRARED INTERFEROMETRIC OBSERVATIONS FROM THE MOON. PART I IS AN INTRODUCTION. PART II IS A DESCRIPTION OF CURRENT AND PLANNED GROUND-BASED INTERFEROMETERS. PART III IS A DESCRIPTION OF POTENTIAL SPACE-BASED INTERFEROMETERS. PART IV ADDRESSES THE POTENTIAL FOR INTERFEROMETRY ON THE MOON. PART V IS THE REPORTS OF THE WORKSHOP'S WORKING GROUPS. CONCLUDING REMARKS, SUMMARY, AND CONCLUSIONS ARE PRESENTED IN PART VI.				
14. SUBJECT TERMS ASTRONOMY, ASTROPHYSICS, TELESCOPES, CELESTIAL BODIES, LUNAR BASES, LUNAR ENVIRONMENT, INTERFEROMETERS, INTERFEROMETRY			15. NUMBER OF PAGES 296	
			16. PRICE CODE A13	
17. SECURITY CLASSIFICATION OF REPORT UNCLASSIFIED	18. SECURITY CLASSIFICATION OF THIS PAGE UNCLASSIFIED	19. SECURITY CLASSIFICATION OF ABSTRACT UNCLASSIFIED	20. LIMITATION OF ABSTRACT UL	