

N 9 3 - 1 3 6 7 2

# HIGH TEMPERATURE STRAIN GAGE APPARENT STRAIN COMPENSATION

H. K. Holmes, T. C. Moore, Sr.  
 NASA Langley Research Center  
 Hampton, Virginia

## INTRODUCTION

Once an installed strain gage is connected to a strain indicating device and the instrument balanced, a subsequent change in temperature of the gage installation will generally produce a resistance change in the gage. This purely temperature-induced resistance change will be registered by the strain indicating device as strain and is referred to (in the U.S.) as *apparent strain* to distinguish it from strain in the test part due to applied stress.<sup>1</sup> Apparent strain is caused by two concurrent and algebraically additive effects in the strain gage installation. First, the electrical resistivity of the gage itself is temperature dependent and, secondly, differential thermal expansion between the gage and the substrate material upon which the gage is bonded creates an apparent mechanical strain. Mathematically, the electrical output of an initially balanced Wheatstone Bridge strain indicator is proportional to the strain experienced by the component resistive strain gages. The strain, as seen by any gage, can be expressed as follows:

$$\begin{aligned} \epsilon_{IS} &= \epsilon_{MS} + \epsilon_{App} \\ &= \epsilon_{MS} + \left[ \frac{\beta_G(T)}{F} + (\alpha_S(T, PO) - \alpha_G(T)) \right] \Delta T \end{aligned}$$

- $\epsilon_{IS}$  = Indicated Strain
- $\epsilon_{MS}$  = Mechanical Strain
- $\epsilon_{App}$  = Apparent Strain
- $\beta_G(T)$  = Resistance Change of Strain Gage due to Temperature
- F = Gage Factor of the Strain Gage Used
- $\alpha_S(T, PO)$  = Coefficient of Expansion of Substrate Material as a Function of Temperature and Substrate Ply Orientation
- $\alpha_G(T)$  = Coefficient of Expansion of Gage as a Function of Temperature
- $\Delta T$  = Temperature Change from an Arbitrary Initial Reference Temperature

The apparent strain, particularly for most currently available high temperature gages, is highly nonlinear, generally non-repeatable, and can exceed the desired mechanical strain by several orders of magnitude. To reduce the apparent strain to an absolute minimum requires the

<sup>1</sup> Technical Note, TN-504, Strain Gage Temperature Effects, Measurement Group, Inc., P.O. Box 27777, Raleigh, North Carolina 27611; 1983.

practitioner to use all the "tricks" in the book and to employ compensation techniques which are highly application-specific.

The most desirable solution for accommodating apparent strain is to employ a gage that has a linear apparent strain relationship as a function of temperature and then employ any additional compensation in the same or adjacent leg of the Wheatstone bridge as required. This installation will most probably require three lead wires from each gage location plus the addition of a precise, probably non-standard, resistance connected in series with the compensation element in order to balance the bridge. If the gage resistance change with temperature is highly nonlinear, one generally ends up only with "end point" compensation, i.e., the bridge is compensated or balanced only at the temperature for which the compensation resistance was determined. Another highly desirable technique for apparent strain compensation is to employ two identical gages with identical mounting procedures which are connected in a "half bridge" configuration where both gages see the same thermal environment but only one experiences a mechanical strain input. Their connection in adjacent arms of the bridge will then balance the thermally induced apparent strains and, in principle, only the mechanical strain remains. Two approaches that implement this latter technique are the subject of this report.

## CO-LOCATED HALF-BRIDGE COMPENSATION TECHNIQUE

### Description

Several popular high temperature strain gages employ various alloys of iron, chromium and aluminum (FeCrAl) whose "apparent strain" output, due to resistance change versus temperature, is the dominant output for these type strain gages. These gages have been typically installed as one arm of a Wheatstone bridge, and when the bonded strain gage is strained (elongated or compressed) the gage resistance changes as a function of the strain. This strain is then converted into an output signal representative of the magnitude of the strain. Unfortunately, the indicated output due to apparent strain resulting from a temperature change is usually far greater than the resistance change generated due to mechanical strains. Additionally, the resistance change is non-linear, non-repeatable, and drifts with time at elevated temperatures.

The compensation concept to be described first is relatively straightforward. If the resistance in adjacent arms of a Wheatstone bridge remains equal to each other, the output remains nulled. Therefore, if a second strain gage, with an identical thermal coefficient of resistance as that of the gage to be strained, was placed in an adjacent arm of the bridge circuit, the output signal would remain nulled even when temperature changes occurred if no mechanical strain was present. An additional condition is that both gages be subjected to the same rate of temperature change. The condition that the second (compensating) strain gage be non-responsive to mechanical strain inputs while subjected to the same temperature environment as the active gage is achieved through installation procedures.

First, an electrically insulating layer of  $Al_2O_3$ , approximately three mils thick and of sufficient area to contain the active and the compensating gage, is applied to the surface to be gaged. The gages are placed on the  $Al_2O_3$  substrate and the active gage is bonded to the substrate using a flame spray system while the compensating gage is only "tack-bonded" at a few points, arranged so that it cannot respond to mechanical strains. Figure 1 is a photograph showing the active gage partially bonded and the compensating gage tack-bonded. This is the only bonding that the compensating gage will receive. Figure 2 shows the active and compensating gage after all flame spraying is completed. Note that the active gage is completely covered while the compensating gage is exposed except for the tack-bonded areas.

ORIGINAL PAGE  
BLACK AND WHITE PHOTOGRAPH

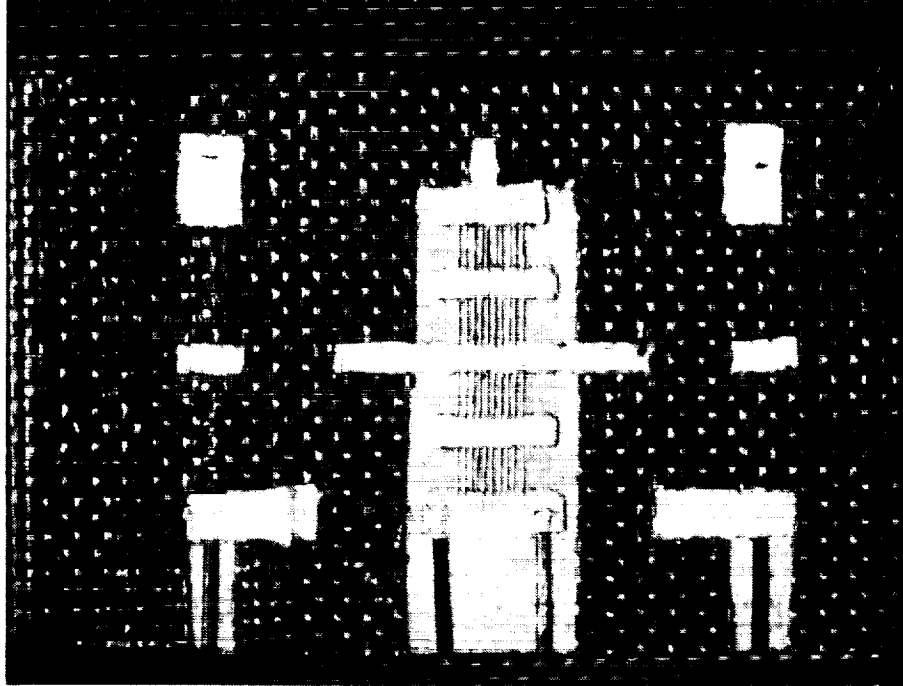

Figure 1. Gages and lead wires tacked in place and active gage ready for attachment.

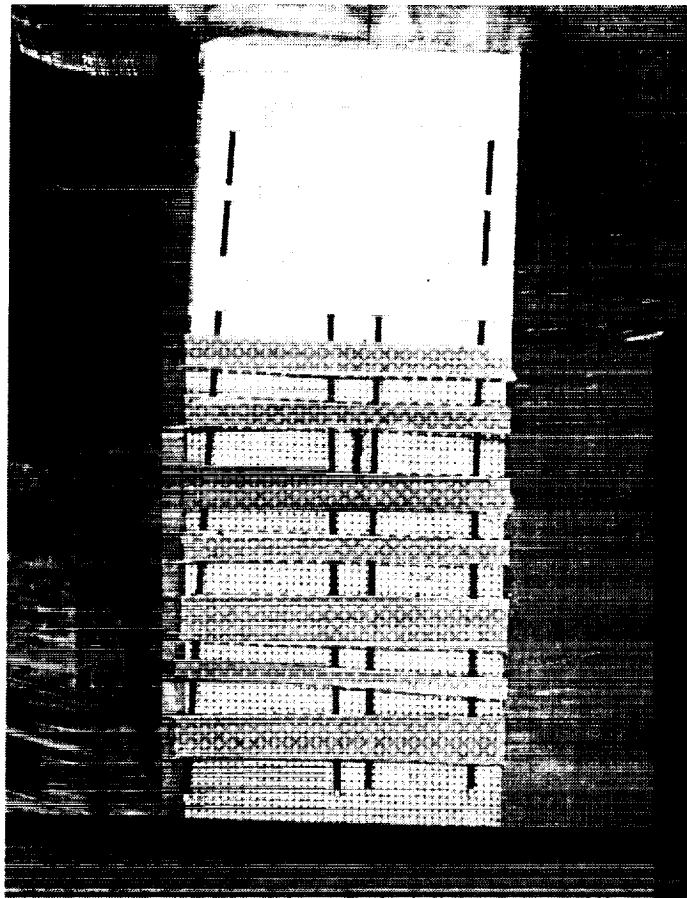

Figure 2. Active gage bonded and compensating gage exposed.

The next step requires the installation of a "thermal blanket" which attempts to maintain isothermal conditions for both gages. The thermal blanket is a sheet of a high temperature woven ceramic cloth which has the top (exposed) surface flame sprayed with a coating of  $Al_2O_3$  while the underside remains soft. This blanket is cut to shape, placed over the active and compensating gages, and then secured to the test article surface either by strapping and spotwelding or bonding with a high temperature ceramic cement. The thermal blanket, shown in figure 3, is ready for installation. Because the inactive (compensating) gage is on the same substrate material and at the same relative height above the test surface as the active gage, and because the surface coating of the thermal blanket cover is of the same material as that used in bonding the active gage, both gages are subjected to the same rate of temperature change even when moderately high heat fluxes are encountered. A photograph of the LaRC developed "compensated high temperature strain gage" is shown wired and ready for testing in figure 4.

### Test Results and Discussion (Co-located Compensation Technique)

Figure 5 shows the typical apparent strains generated by several commercially available high temperature strain gages and compare the apparent strain with two types of compensated high temperature gages. The commercially available single element gages reveal apparent strains 20 to 30 times the magnitude of the compensated gages. The Palladium-Chrome (Pd.-Cr.) compensated gage does an excellent job of correcting for apparent strain and is under development at the NASA Lewis Research Center. It does, however, require a prestabilization period of considerable length at high temperature in order to obtain repeatable apparent strain correction as shown in the plot. The Langley Research Center developed gage requires no prestabilization, and the initial run to  $540^\circ C$  generated very small apparent strains and a small zero shift during the cool-down portion of the run as seen in the figure. The dotted line shown for the Langley gage was the second apparent strain run for the gage, but the first excursion extended to  $800^\circ C$ . Note the repeatability of the apparent strain with the first excursion to 800 degrees C. Figure 6 shows subsequent apparent strain runs up to  $815^\circ C$  ( $1500^\circ F$ ) and, again, excellent repeatability was observed as well as small total apparent strains at  $1500^\circ F$ .

Beta 21S titanium matrix composite (TMC) is a material of great interest to the NASP program and will require high temperature strain measurements. The Langley developed compensated gage has been installed on several McDonnell Douglas furnished Beta 21S TMC coupons, and test results have been very encouraging. Even though the coefficient of expansion of the compensated gage alloy is not matched to TMC, the gage managed to provide relatively small apparent strains from room temperature to  $1500^\circ F$ . More importantly, all of the gages tested generated virtually the same apparent strain slope for all of the coupons tested. Also, exceedingly important for structural testing, the apparent strain curve obtained during the first temperature excursion exhibits very small zero shifts. This allows the test engineer to obtain static strain data during the first heat-up of the test article. Large zero shifts during the first cycle cool-down are routine for all of the commercially available single element high temperature gages.

Figure 7 is a plot comparing the Langley Chinese alloy compensated gage with a popular single element high temperature gage (type NZ-2104). As shown, the Langley gage's apparent strain curve is virtually linear with no zero shift during the cool-down phase of the temperature run, while the NZ gage has a terribly non-linear apparent strain curve and a large zero shift during the cool-down to room temperature. Also, the gage generates a much larger total apparent strain than does the LaRC gage. Three apparent strain runs to  $1200^\circ F$  were conducted on this coupon and the Langley gage generated 3805 micro-strain at  $1200^\circ F$ , within 1.5 percent, for all three runs. The NZ gage generated strains that varied between 4815 and 6360 micro-strain with zero shifts as large as 1990 micro-strain. The poor apparent strain performance of the NZ gage is typical of high temperature strain gages when no prestabilization of the gage at elevated temperature is allowed prior to testing.

ORIGINAL PAGE  
BLACK AND WHITE PHOTOGRAPH

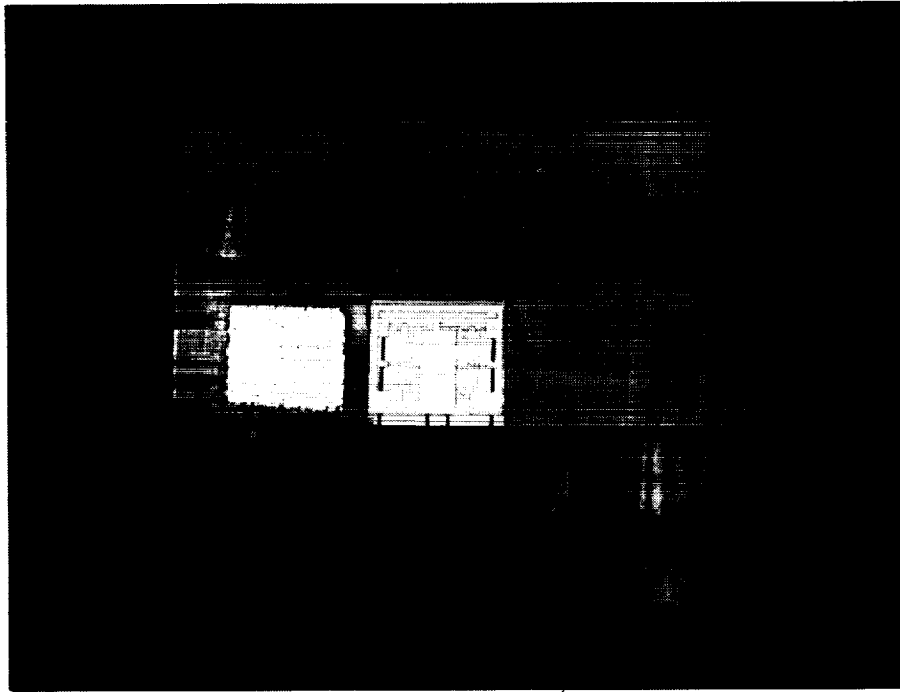

Figure 3. Nextel blanket with Alumina overcoating ready for installation.

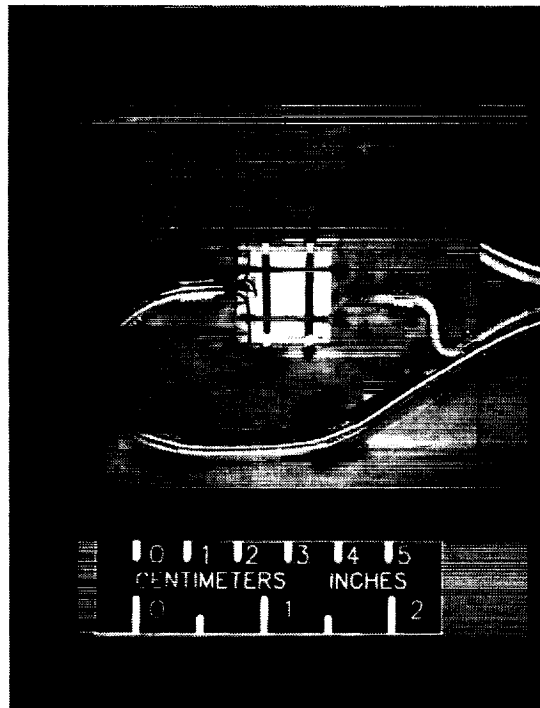

Figure 4. Final assembly. Nextel blanket secured and lead wires attached.

## THERMAL OUTPUT COMPARISONS UNCOMPENSATED VS COMPENSATED

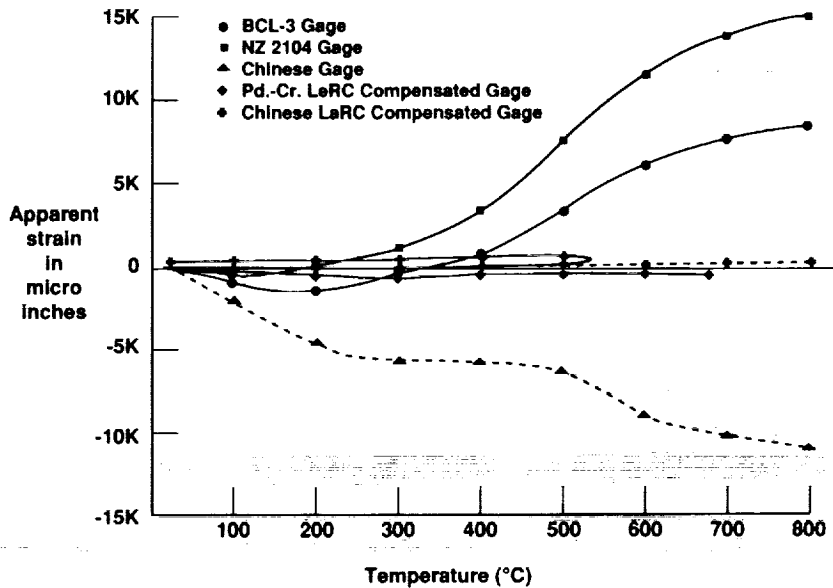

Figure 5. Apparent strain from several gages compared.

## THREE CONSECUTIVE APPARENT STRAIN RUNS TO 1500°F CHINESE ALLOY GAGES

One Active Gage, One Compensation Gage Wired  
Together To Form A Half Bridge

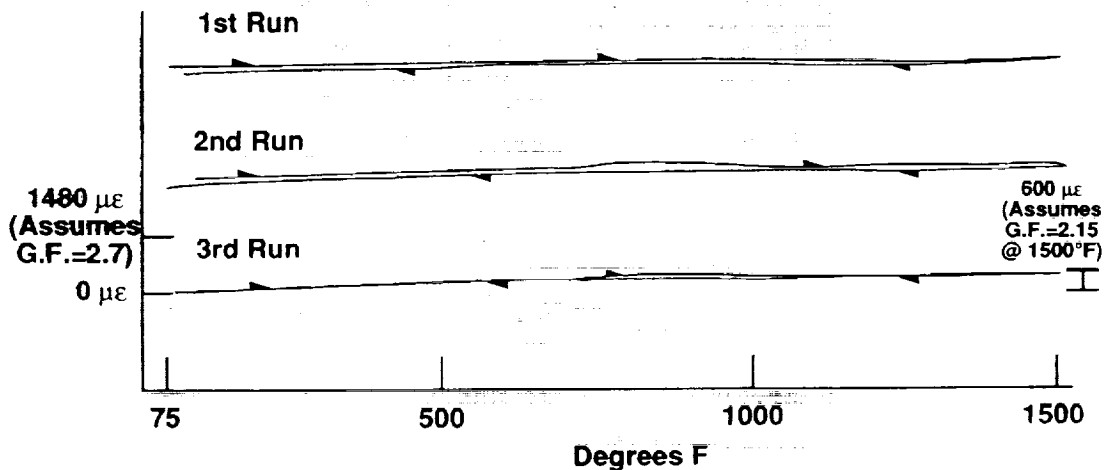

Figure 6. Three apparent strain runs to 1500°F on IN-750 test beams.

LaRC APPARENT STRAIN TEST  
MDLSS TMC COUPON APPARENT STRAIN TEST

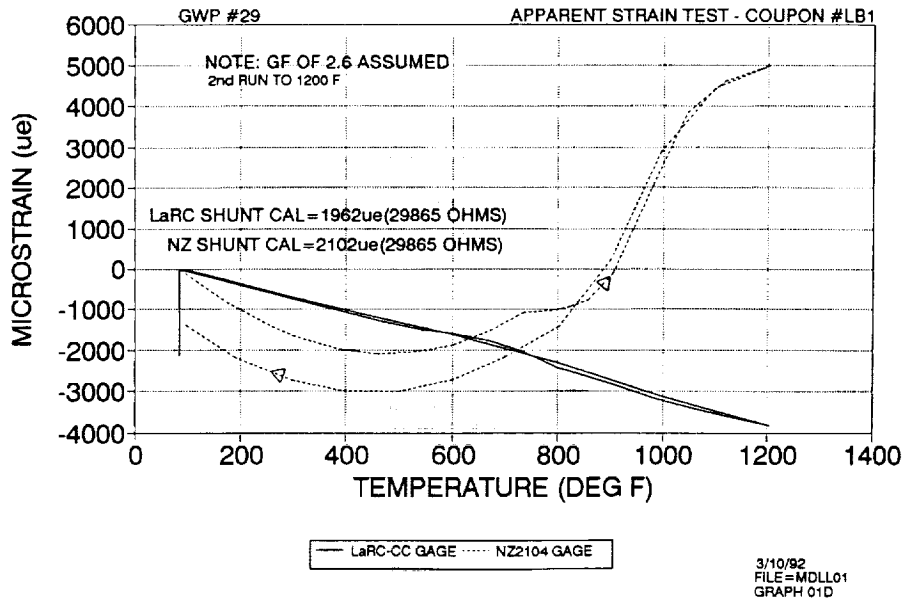

Figure 7. Apparent strain of compensated gage and NZ-2104 gage on TMC coupon.

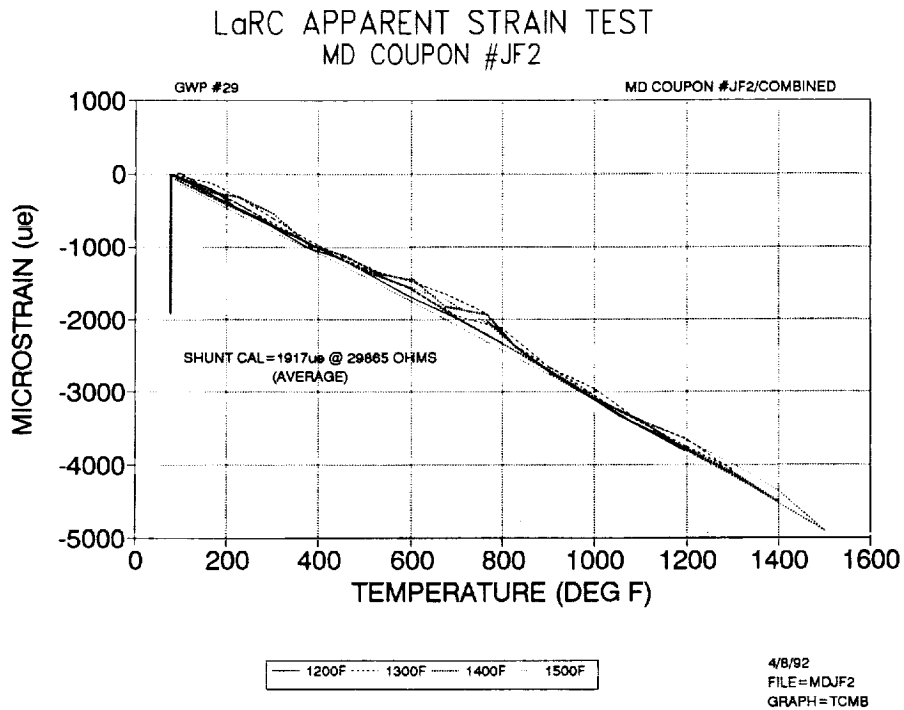

Figure 8. Repetitive apparent strain runs to different  $T_{max}$  on 2<sup>nd</sup> TMC coupon.

## HIGH TEMPERATURE APPARENT STRAIN COMPENSATION SYSTEM

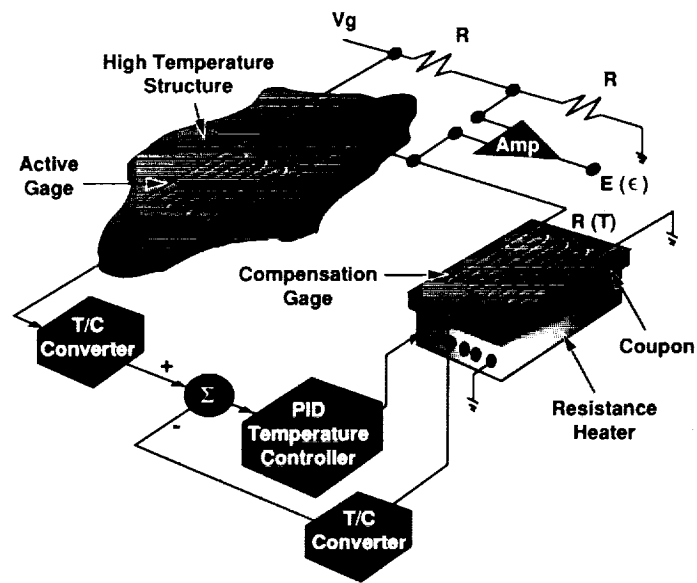

Figure 9. Schematic of remote compensation concept.



Test results from another LaRC compensated gage on a second TMC coupon were also encouraging. A series of apparent strains were conducted with the plots shown in figure 8. Shown is the first temperature excursion to each of four temperatures and the cool-down to room temperature. Note that the slope is virtually the same for all four temperatures, and that zero shifts at room temperature following the cool-down are very small. Even though this second coupon was a 4-ply coupon (the first was a 6-ply), both Langley gages generated 3800 micro-strain at 1200°F on each coupon. This agreement builds confidence in the ability to correct for the thermally induced apparent strain for test articles fabricated of this material.

## REMOTE COMPENSATION TECHNIQUE

### Description

An alternative, somewhat complicated, yet feasible approach to compensating high temperature strain gages is the subject of the balance of this report and is illustrated in figure 9. Conceptually stated, a high temperature strain gage and a thermocouple, located in the closest proximity to the gage, are attached to the structure of interest. The Wheatstone Bridge completion resistors, including the adjacent bridge element, are housed in the signal conditioning and power supply electronics unit. The adjacent arm of the bridge consists of a matched, high-temperature strain gage attached to a coupon having identical material properties as the main structure and similarly oriented with respect to ply orientation, and includes a thermocouple located in the same proximity to the compensation or dummy gage as the first is to the active gage.

Next, a controllable heater element attached to the coupon maintains the temperature of the coupon identical with that of the structure under investigation as measured by the respective thermocouples. With this approach, the apparent strain due to temperature is compensated for by utilizing a "matched" (same temperature coefficient of resistance) gage, and the apparent strain due to differential expansion is compensated by utilizing the same substrate material, ply orientation and mounting techniques. By controlling the temperature of the adjacent bridge element with a PID (proportional plus integral plus derivative) controller, one can maintain temperature control with a zero temperature error.

Figure 10 is a block diagram of a closed loop control system where the reference input is the analog of the measurement gage temperature and the controlled output is an analog of the compensation gage temperature expressed in the z-transform domain. The difference in these two quantities is the error signal which one wants to be zero. The digital controller consists of the necessary sample-and-hold, analog-to-digital conversion, algorithmic processing, amplitude scaling, and digital-to-analog conversion circuitry to control the input to the plant. The plant consists of the necessary heater element, sample material specimen, compensation gage, connecting wiring, mounting materials, and the requisite thermocouple needed to sense the controlled temperature and provide the feedback signal needed to close the loop.

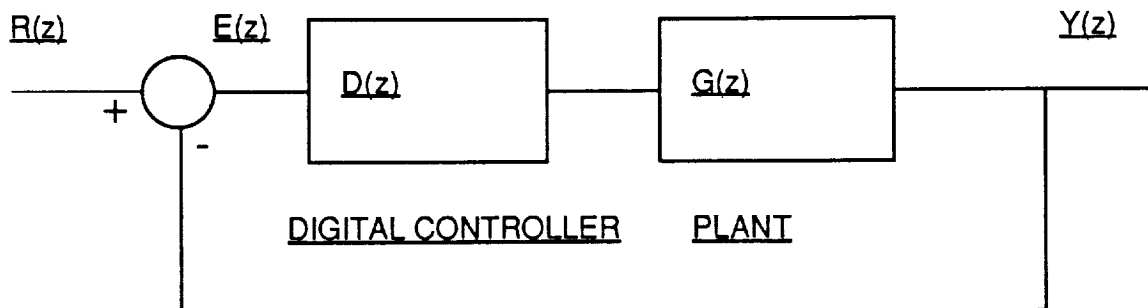

Figure 10 - CONTROL SYSTEM BLOCK DIAGRAM

Figure 11 expands on figure 10 and reveals more detail about the closed loop system as well as details of the Wheatstone bridge which show the measurement resistance  $R(3)$  in one arm of the bridge and the compensation resistor  $R(4)$  in the adjacent arm. Thermocouples provide a measurement of the respective strain gage temperatures and are the reference input and the controlled output signals of the system. The output of the bridge  $E_o$  is dependent only on the mechanical strain seen by the element  $R(3)$  because the temperature induced effects on the measurement gage are compensated by the same temperature induced effects on an identical gage connected in the adjacent bridge arm. Also, from figure 3 one can see the parallel nature of the three control actions, proportional, integral and derivative, which act on the error signal. If proportional control only was used, a non-zero error signal would result because an input is required to maintain an output. Adding the integral control action allows the error signal to be driven to zero, the input necessary to sustain an output is held on the integrator's capacitive feedback element. Derivative control provides a method to control overshoot in the output signal by modifying the rate at which the error signal is allowed to change.

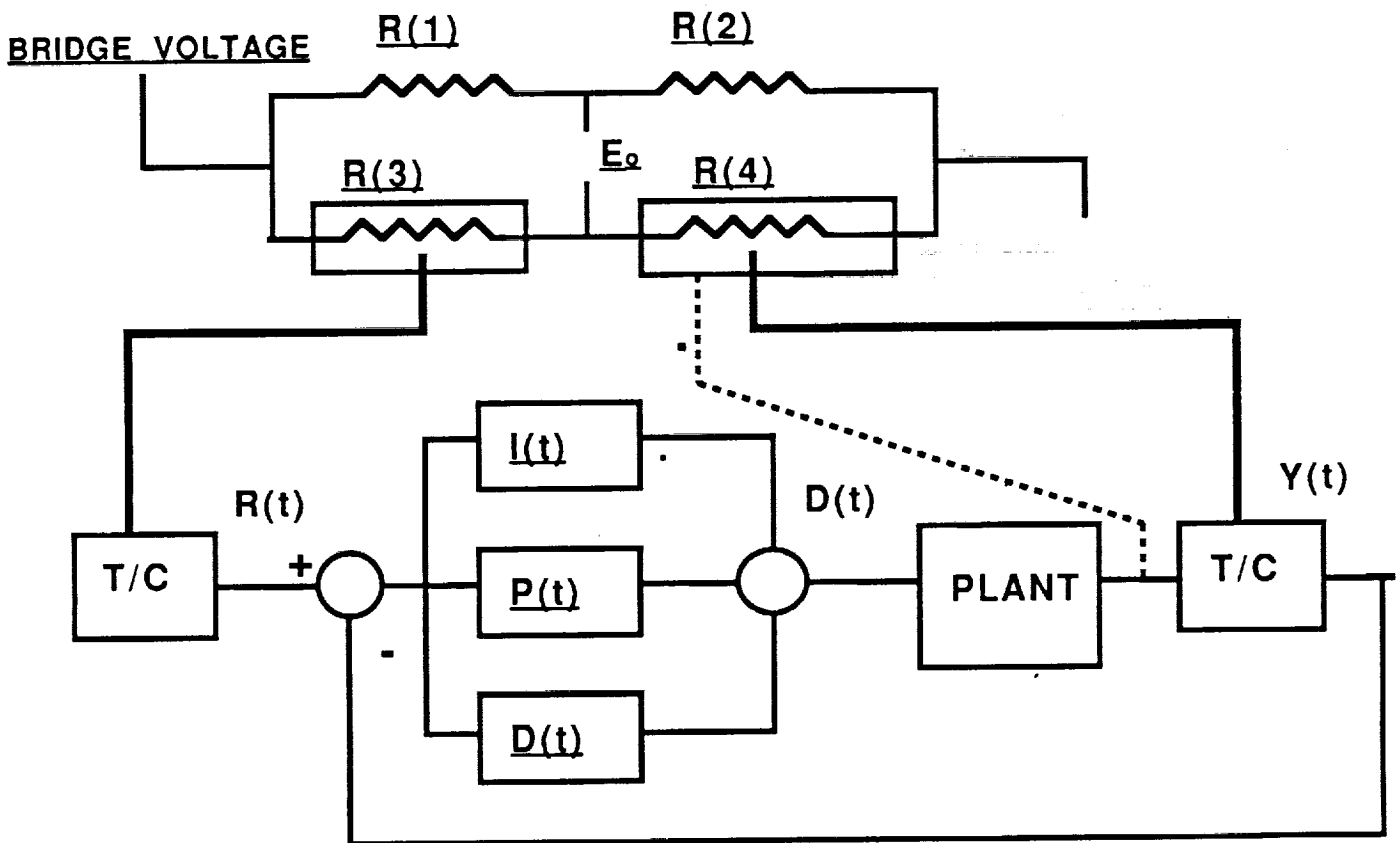

Figure 11 - CONTROL SYSTEM SCHEMATIC INCLUDING EXPANDED DIGITAL CONTROL ELEMENT AND THE MEASUREMENT WHEATSTONE BRIDGE

As can be seen from figures 9 and 10 and the associated text, a concept for compensating a resistance strain gage to eliminate the apparent strain effects resulting from temperature variations has been described. With this method, non-linear effects due to the alloy composition of the gage, coefficient of expansion differences between the gage and substrate and, to a degree, ply orientation of the substrate material have been compensated for by requiring the adjacent bridge arm resistor to exist in an environment controlled to be as close to the measurement gage environment as is possible. With this control, the apparent strain effects are nullified.

## Test Results and Discussion (Remote Compensation Technique)

Preliminary runs were made using NZ-2104 FeCrAl gages, previously utilized in apparent strain studies, mounted on IN-750 test bars. One specimen was placed in a clam-shell oven, destined for use on a tensile test machine, and the second was placed in an aluminum minibox with heat being supplied by a fan driven, electric "paint stripper." The primary purpose of the initial tests was to test the system's ability to control and track temperatures in two separate ovens. The heat-up rate in the clam-shell oven was set to approximately 5°F per minute, and it was found that the controlled specimen tracked the reference specimen within 2 to 2.5°F in both the heat-up and the cool-down phases. The controlled specimen's enclosure was poorly insulated so that control in the cool-down mode was primarily the addition of less heat input in response to a slowly decreasing reference temperature.

During these trials, the two gages were connected in a quarter bridge configuration, and apparent strains showed similar but disparate behavior. When connected in a half-bridge configuration, the apparent strain output was quite low but not as low as was expected. It was hypothesized that the two specimens had not been cycled to the same upper temperatures and thus the metallurgical state of the two gages was dissimilar. The two specimens were then placed in an oven and thermally soaked at 1300°F for two hours.

Figure 12 shows the apparent strain obtained from the two gages in separate ovens but connected in a quarter bridge configuration. One can see the similarity but some definite disparity. The gages were then connected in a half bridge electrical configuration and a test to 550°C conducted with the results as shown in figure 13. It is seen that the residual, or not compensable, apparent strain is approximately 300 micro-strain where the uncompensated, single NZ-2104 gage at these temperatures might have on the order of 4000 to 6000 "apparent" micro strain output.

## CONCLUSIONS

Because the compensated half-bridge approach can be applied at most locations where a quarter-bridge gage has historically been utilized, it should see wide use in high temperature test structures, especially where static strain measurements are a must. The gaging concept has many advantages which included the ability to obtain static strain data during the first temperature excursion due to the gage's half-bridge configuration which cancels the non-linearity and non-repeatability of a single active gage; the ability to minimize the thermal output throughout the temperature excursion as opposed to nulling at one temperature only; and, because of the insensitivity of the inactive gage to mechanical strains, the sensitivity (gage factor) of the bridge circuit will not be compromised. Finally, the precipitous slope and the non-repeatability of the thermal outputs of "hi-temperature" strain gages cause the accuracy of the data to be in question.

The ability to virtually eliminate the thermal output using the active/inactive gage method should dramatically improve data accuracy while alleviating the need to accurately measure the temperature of a single gage when attempting to use a quarter-bridge strain gage circuit. Additionally, the remotely located half-bridge compensation method has the potential to compensate thermal expansion disparities as well as the resistive component. This method has a second possible attribute of being able to selectively switch several active gages to connect with one completion and controlled gage thus obtaining a relatively higher "apparent strain" compensation with less expensive or specialized gages. In this procedure, the task is now to develop a more sophisticated remotely controlled oven so fast transient response can be achieved.

It is apparent from the material presented in this report that two technically viable, straightforward approaches to eliminating or minimizing the effects of "apparent strain" in high temperature strain measurements have been demonstrated.

# APPARENT STRAIN COMPEN. SYSTEM

## APP. STRAINS FOR INDIVIDUAL GAGES

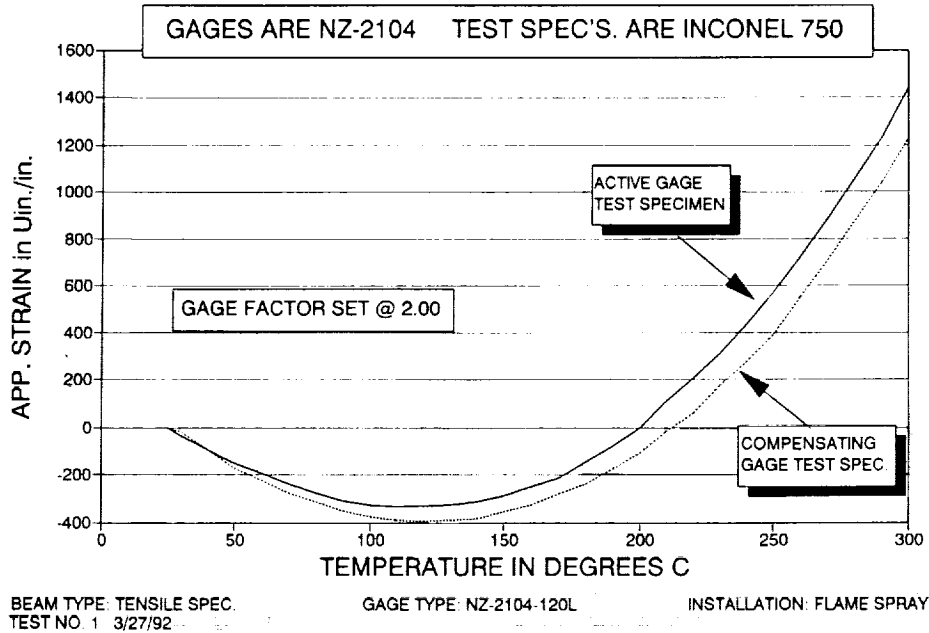

Figure 12. Apparent strain of two NZ-2104 on Individual IN-750 test beams.

# APPARENT STRAIN COMPEN. SYSTEM

## APP. STRAIN AS A HALF-BRIDGE

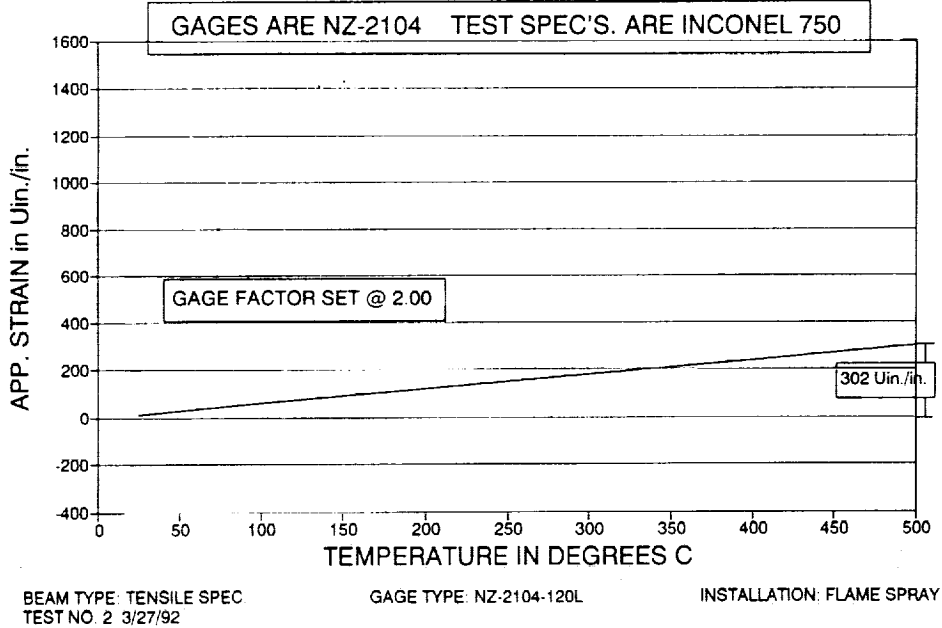

Figure 13. Apparent strain with the two NZ-2104 gages connected in a half-bridge configuration but in different ovens.