

NASA Contractor Report 189115

114 22
136200
P.12

Autonomous Power System Brassboard

Anthony Merolla
Sverdrup Technology, Inc.
Lewis Research Center Group
Brook Park, Ohio

(NASA-CR-189115) AUTONOMOUS POWER
SYSTEM BRASSBOARD Final Report
(Sverdrup Technology) 12 p

N93-14798

Unclass

October 1992

G3/33 0136200

Prepared for
Lewis Research Center
Under Contract NAS3-25266

NASA
National Aeronautics and
Space Administration



AUTONOMOUS POWER SYSTEM BRASSBOARD

Anthony Merolla
Sverdrup Technology, Inc.
Lewis Research Center Group
Brook Park, Ohio 44142

SUMMARY

The Autonomous Power System (APS) brassboard is a 20 kHz power distribution system which has been developed at NASA Lewis Research Center, Cleveland, Ohio. The brassboard exists to provide a realistic hardware platform capable of testing artificially intelligent (AI) software. The brassboard's power circuit topology is based upon a Power Distribution Control Unit (PDCU), which is a subset of an advanced development 20 kHz electrical power system (EPS) testbed, originally designed for Space Station Freedom (SSF).

The APS program is designed to demonstrate the application of intelligent software as a fault detection, isolation, and recovery methodology for space power systems. This report discusses both the hardware and software elements used to construct the present configuration of the brassboard.

The brassboard power components are described. These include the solid-state switches (herein referred to as switchgear), transformers, sources, and loads. Closely linked to this power portion of the brassboard is the first level of embedded control. Hardware used to implement this control and its associated software is discussed. An Ada software program, developed by Lewis Research Center's Space Station Freedom Directorate for their 20 kHz testbed, is used to control the brassboard's switchgear, as well as monitor key brassboard parameters through sensors located within these switches. The Ada code is downloaded from a PC/AT, and is resident within the 8086 microprocessor-based embedded controllers. The PC/AT is also used for smart terminal emulation, capable of controlling the switchgear as well as displaying data from them. Intelligent control is provided through use of a TI Explorer and the Autonomous Power EXpert (APEX) LISP software. Real-time load scheduling is implemented through use of a "C" program-based scheduling engine. The methods of communication between these computers and the brassboard are explored.

In order to evaluate the features of both the brassboard hardware and intelligent controlling software, fault circuits have been developed and integrated as part of the brassboard. A description of these fault circuits and their function is included.

The brassboard has become an extremely useful test facility, promoting artificial intelligence (AI) applications for power distribution systems. However, there are elements of the brassboard which could be enhanced, thus improving system performance. Modifications and enhancements to improve the brassboard's operation are discussed.

INTRODUCTION

All power distribution systems require a mechanism of control and protection. For example, the circuit breaker panel in a home both distributes power and protects each set of subfeed branch conductors. That is, a circuit breaker routes power to a specific load, as well as protects the conductor feeding the load. The home circuit breaker panel is an example of a simple distribution system. In contrast, one needs to consider the complexity of a commercial utility and the need to control such a vast power system. Such complexity invites the utilization of embedded processors, personal computers, and artificial

intelligence (AI) as the control media of any power system. In fact, applying computer processing power, specifically AI, is becoming increasingly important when space power systems are discussed.

Efficient, autonomous management of sources, distribution, users, and fault recovery is critical for any space power system. These factors drive the development of the Autonomous Power System (APS) brassboard at NASA Lewis Research Center, Cleveland, Ohio.

The evaluation of an intelligent (AI) software system required that it be interfaced to real-time hardware. This hardware element has evolved into the brassboard. The brassboard's circuit topology is based on a Power Distribution Control Unit (PDCU), which is a subset of Space Station Freedom's (SSF) early baseline 20 kHz electrical power system (EPS).

The goal of the APS program is to develop intelligent software as the control medium for a large hierarchical power system, with initial focus on the SSF 20 kHz EPS. Modeling the brassboard upon one PDCU, versus a clean sheet of paper design, permits greater emphasis on AI software development and hardware refinements. It also provides a scaled transition to a larger configuration. In order to reduce the AI design overhead the brassboard's embedded controllers utilize an Ada program, also developed by SSF, to implement the low level hardware control. The Ada code has been slightly modified to address the specific needs for knowledge-based data acquisition from the APS brassboard.

The AI software has been completely developed in-house. The result is the Autonomous Power EXpert (APEX). APEX has the capability to monitor all key brassboard parameters, and can control the state of the brassboard through fault diagnostics, prediction, and correction. A software scheduler has also been developed. The scheduler, together with APEX, forms the engine, which can dynamically control the brassboard.

This report discusses the brassboard's power components, embedded controllers, and control computer interfaces. The fault circuits, which have been designed to exercise both APEX and the power components, are described. Finally, a few hardware modifications are suggested which could enhance the performance of the complete system.

HARDWARE DESCRIPTION

The brassboard, although modified, has been constructed to model one PDCU. As such, the brassboard contains 20 kHz switchgear, transformers, and both an inverter and power amplifier as its power sources (refs. 1, 2, and unpublished data¹). Figure 1 shows a block diagram of these components as implemented on the brassboard.

The brassboard has been specified to operate within the following limits. The bus frequency is 20 kHz. Source 1 (power amplifier) supplies 120 V to the step-up transformer, T1-A. Source 2 (inverter) provides 240 V to the isolation transformer, T2-A, which yields the brassboard's primary bus voltage of 240 Vrms, ± 10 Vrms. The step-down transformers, T1 through T3, then provide a secondary bus voltage of 120 Vrms, ± 5 Vrms. All switchgear (remote bus isolators (RBIs) and remote power controllers (RPCs)) will conduct a maximum of 10 Arms, before instantaneously tripping.

¹Design Specification for Breadboard Switchgear Equipment for 20 kHz Space Station Test Bed. Design Spec. No. D-570A26, Westinghouse, Lima, Ohio, unpublished.

Switchgear

The 20 kHz switchgear constitutes a majority of the brassboard's hardware. Each RBI and RPC contains the following basic circuits: a power supply; 20 kHz signal sense, conditioning, and control; a 1553B interface; and a solid-state switch (back-to-back silicon controlled rectifiers (SCRs)). As an exception, the RBIs include an electrical contactor connected in parallel with the solid-state switch. This contactor minimizes the SCRs' conduction losses. As a result, the RBIs are capable of conducting more current than the RPCs. A block diagram of the switchgear is shown in figure 2. The switchgear was developed by Westinghouse Aerospace, Lima, Ohio.

The switchgear power supply circuit converts 28 Vdc into 5, +15, and -15 volts. A current-mode, switching regulator is used as the heart of this dc supply. All logic, analog, interface, and SCR gate drive circuits derive their bus power from this supply.

The 20 kHz signal sense, conditioning, and control circuits provide voltage, current, and phase angle measurements at 20 kHz. A separate circuit calculates power from the measured voltage and current values. The overcurrent trip level, which is software programmable, is set within this hardware. Another circuit block controls the SCR switch and (for the RBIs only) electrical contactor. This specific circuit provides basic on-off operation for each RBI and RPC.

The analog signals discussed above require digitizing in order to complete communication between the microprocessor and the switchgear. To accomplish this, 8-bit digital conversion is used. A MIL-STD-1553B interface circuit is then used to complete communication between the embedded controllers (microprocessor-based) and all switchgear. The 1553B is a military standard, dual-redundant, serial data bus.

Each RBI and RPC uses back-to-back SCRs as the primary switching element in both the line and neutral conducting paths of the device (ref. 1). The SCRs are high voltage, moderate current devices. However, to increase the conduction capability and reduce the power loss of the RBIs, an electrical contactor has been connected in parallel with each pair of SCRs. The RBIs were originally designed to operate at 880 Vrms, 50 Arms and the RPCs at 880 Vrms, 25 Arms (ref. 2).

The above limits are oversized for the present brassboard configuration. Hence, circuit modifications were made to each RBI and RPC. That is, each device was rescaled for lower voltage and current levels of 500 V, 10 A for the RBIs and 250 V, 10 A for the RPCs. These reduced levels yield better tolerance and resolution for the control software.

Transformers

The 20 kHz transformers are rated at 25 kVA and were originally intended to step down 440 V to 220 V (ref. 2). The 440 V primary and 220 V secondary were to be used as the baseline bus voltages for Space Station Freedom's 20 kHz electrical power system. Figure 1 though shows that the brassboard's primary bus voltage is 240 V with a secondary bus voltage of 120 V. These lower voltages are used to minimize the stress on the SCR portion of RBI 3/2 (fig. 1), the cross-tie switch. However, as a first generation prototype, the brassboard's bus voltage could be scaled up through the use of newer, higher capacity semiconductor devices.

Each transformer may be configured as a buck, boost, or isolation device (fig. 1). All of these configurations are used on the brassboard. The transformers were developed by Westinghouse.

Sources

There are two sources which supply 20 kHz to the brassboard. Source 1 is a 1.5 kW power amplifier, commercially available from Electronic Navigation Industries, Inc. (ENI). An external oscillator and regulator provide the 20 kHz input. A 120 Vrms output is generated with regulation less than 2 percent.

Source 2 is a 12 kW Mapham inverter which was developed by General Dynamics Corp. (GDC). A 240 Vrms output is generated with regulation typically less than 2 percent. This source provides the bulk of the brassboard's power.

Loads

The brassboard uses standard (60 Hz) incandescent and heat lamp light bulbs as loads. A power resistor is connected in series between the RPC and its lighting load bank. This resistor limits the cold filament in-rush current, thus providing a soft turn-on of each load bank.

CONTROLLERS

Switchgear control and data transfer is accomplished through use of 8086 microprocessor-based controllers. Presently, two controllers are used with one a subsidiary to the other. The Power Management Controller (PMC) is at the highest level of control. It has the capability to coordinate lower level controllers (ref. 2). A Power Distribution Controller (PDC) provides a low level control interface to all brassboard switchgear through the 1553B data bus.

Each controllers' processing power is based upon an Intel iSBC 86/35 single board computer, which is enhanced with an iSBC 337A add-on card for an 8087 math co-processor. Each controller uses the MULTIBUS I (IEEE 796) as its backplane and thus a commercially available MULTIBUS I system chassis. Each controller also includes an Intel iSXM 552A (IEEE 802.3) communication engine and an Electronic Solutions PROM 64/256 memory expansion board. In addition to the above, the PDC contains a DDC BUS-65509 1553B/MULTIBUS interface board.

Both software and firmware are used to implement communication, control, and data transfer among the switchgear, controllers, and high level computers. Intel's iNA961 is a transport and network software system, which includes a data driver, preconfigured for the iSXM 552A. A monitor program is used to implement serial communication between the controllers and higher level computers. (The monitor was developed by Michael Mackin, NASA Lewis Research Center.) Ada software, which resides within the 8086 embedded controllers, is used to operate both the PMC and PDC (ref. 3). The Ada software, originally developed by Lewis's SSF directorate and Rocketdyne, Inc., has been modified to enhance control of the brassboard (ref. 4).

COMPUTER INTERFACES AND SOFTWARE

A PC/AT is used to download the Ada control program into the 8086 embedded controllers. The PC/AT also emulates a smart terminal, providing control and data display for the switchgear. Texas Instruments, Inc., (TI) Explorer II LX workstation (also connected to the brassboard's embedded controllers) runs the Autonomous Power EXPert (APEX) LISP software (refs. 4 and 5). APEX may also

acquire data and control the brassboard switchgear independently of the PC/AT. The TI Explorer, along with APEX, performs the brassboard's highest level of control.

Communication between the brassboard's 8086 based controllers and either the PC/AT or TI Explorer requires peripheral hardware and software I/O elements. The PC/AT downloads the Ada code to both the PMC and PDC through an Ethernet link. Excelan's EXOS 205T Intelligent Ethernet Controller PC card and associated driver software is used for this purpose. An RS-232 connection also exists between each embedded controller and the PC/AT. The monitor program uses Procomm's PCPLUS software package which includes a serial driver and smart terminal emulator for the PC/AT. The PCPLUS and Ada software yields a medium through which the PC/AT commands and displays the brassboard's switchgear status.

The TI Explorer is also serially (RS-232) connected to the embedded controllers. Its serial driver has been developed in-house. The TI may function independently of the PC/AT. The resident APEX software is therefore capable of directly commanding and displaying the brassboard's switchgear status. In fact, APEX is a closed loop system versus the Ada code's open loop nature. That is, APEX can automatically reconfigure the brassboard for various fault or load scheduling conditions.

APEX was specifically developed for the APS brassboard. It contains a "knowledge base, a data base, an inference engine, and various support/interface [serial] software" (refs. 4 and 5). A software load scheduler is also being developed at Lewis (ref. 6), and together with APEX it enables dynamic control and monitoring for the brassboard. Figure 3 shows the brassboard's control elements, interfaces, and software. For a more detailed discussion of both APEX and the load scheduler see references 4 to 6.

FAULT CIRCUITS

Power systems, whether they are vast commercial utilities or regulated dc power supplies, require safe recovery from fault conditions. This is also a requirement of the APS brassboard. That is, between APEX, the load scheduler, and the overcurrent protection designed into the switchgear, various brassboard faults must be detected and either safely removed or the system reconfigured to prevent catastrophic failure and damage.

In order to "safe" the brassboard, a set of rules has been developed based upon certain behavioral knowledge of the brassboard. These rules are then translated and programmed in LISP to form the intelligent software system, or APEX. APEX has been designed to monitor, diagnose anomalies, and then recommend or take corrective action, saving the brassboard. Primary fault containment is accomplished, however, in each RBI and RPC through programmable overcurrent trip limits. Each switchgear will then trip when an overcurrent condition occurs, similar to the way a circuit breaker operates.

Therefore, in order to evaluate the saving capability of both APEX and the switchgear, actual hardware faults have been designed and integrated with the brassboard. These faults may be classified as either soft, hard, or incipient.

A soft fault is characterized as a state of the brassboard which exceeds the expected norm, but will not cause immediate catastrophic failure. A soft fault may manifest itself as line-to-line leakage currents, IR drops caused by loose contacts, or a partial decrease in source generation capability. Clearing these faults is required and essential, but not critical.

A hard fault is an abrupt change from the expected norm which leads to a catastrophic failure, such as a complete loss of a source or a short circuit. In the event of a short circuit, the branch RPC or RBI will open immediately, removing this fault from the system. As one would expect, such faults require immediate action which is critical for the system's safe operation.

Finally, incipient faults are time dependent failures which initially are rather innocuous, but could steadily increase through time. In fact, at the incipient fault's onset, it may not even be classified as a soft fault. However, as time progresses the fault's severity may increase. An incipient fault may manifest itself as device or material degradation, for instance, wire insulation deterioration or a degrading SCR in an RBI or RPC. These trends are monitored by APEX as a history of the brassboard. When anomalous behavior is detected, APEX will again act to safe the brassboard by, for example, notifying an operator of the potential device failure.

Hardware has been developed which will implement either soft or incipient faults as outlined above. Hard faults are not currently implemented on the brassboard. The following section describes the brassboard's various soft and incipient fault capability.

Soft Faults

Six circuits have been developed which induce a variety of soft faults on the brassboard. Two faults yield line-to-line and line-to-ground low current leakage paths. Also, there are two circuits which will decrease Source 1's voltage by 25 percent or induce a significant IR drop of 25 percent between this source and transformer T1-A. Another circuit inhibits the gate drive to one of the RPC's switching SCRs. Thus, when this RPC is turned on, its load side voltage will be one-half the line side, as shown in figure 4. The last circuit induces a modest IR loss, decreasing the RPC's bus voltage 6 to 7 V, which is just below the 5 V tolerance band.

Incipient Faults

An incipient fault is implemented through use of Energy Systems' Modular Programmable Electronic Load System (MPELS). The MPELS is an automated 30 kW solid-state load bank, operational at the maximums of 20 kHz and 440 Vrms. The MPELS may be programmed in a power, current, or resistive mode. Time intervals are also programmable. For example, the MPELS may be set to dissipate 1 kW for 30 sec, then turn off. Or, at time = 0, the MPELS will be set to 1 k Ω , then linearly decrease to 10 Ω through a 60 sec interval. The MPELS is useable at various nodes throughout the brassboard.

POSSIBLE MODIFICATIONS

The brassboard, in conjunction with APEX, has become a valuable platform, which explores the application of intelligent software as the control media of a power distribution system. The brassboard's operation and performance have been successful in advancing the aforementioned concept. However, minor modifications to the existing hardware could enhance overall system performance. These elements of interest include the switchgear, sources, and loads.

Switchgear

Both RBIs and RPCs use 8-bit analog-to-digital (A/D) conversion. That is, voltage, current, power, and phase angle signals are converted from their analog levels to an 8-bit digital word. This yields a best possible resolution of 0.39 percent, and although this is a good number, 12-bit conversion yields resolution less than 0.02 percent, a very desirable result. In effect, using 12-bit A/D conversion would increase data resolution and minimize data scatter, thus increasing the sensitivity and performance of APEX.

The switchgear uses a switching dc-dc supply for instrumentation and drive circuitry power. Regulation and ripple, for any dc level (for instance ± 15 , 5 V, and so forth), measures typically at 2 to 3 percent and 200 to 500 mV, respectively. A reduction in the ripple component, however, could improve the signal-to-noise ratio. Such a modification should improve the data scatter now experienced by APEX.

Both RBIs and RPCs operate as single-pole circuit breaking devices. In order to increase the RPC functionality it would be advantageous to convert it to independent two-pole operation. That is, each pair of SCRs within the RPC would be used to independently control two loads versus a single load.

Finally, the inclusion of other measured parameters could further enhance APEX's control of the brassboard. One such parameter would include temperature. The data generated from a temperature transducer would be most useful as a correlation element, when APEX is logging historical trends for incipient faults.

Sources

Improved 20 kHz generating capability is also of interest. Reliable, well regulated, high frequency power supplies have been shown to play a major role in the brassboard's operation. Both the Mapham inverter and ENI power amplifier have functioned reasonably well. However, tighter regulation and greater waveform fidelity would improve operations and permit a greater number of load and fault scenarios. These variations would further be used to evaluate APEX's performance.

Loads

Light bulbs have been used to statically load the brassboard. However, it will become increasingly valuable to demonstrate 20 kHz operation of dynamic loads. A dynamic load's energy requirement will vary throughout time, for instance, in a motor or electromechanical actuator. The behavior of a dynamic load would therefore yield a more realistic load profile to the brassboard.

Adding another PDCU would also allow greater load complexity. Increasing the number of loads would also present a more complex power distribution system to APEX. This system would also allow more complicated fault diagnostic and scenario evaluations.

Implementing these modifications is a reasonable engineering task. The potential benefits include greater resolution and sensitivity of switchgear parameters, improved system regulation and fidelity, and a more realistic load environment. These enhancements would provide a more interesting challenge to APEX's capabilities and responsiveness.

CONCLUSION

When originally conceived, the Autonomous Power System (APS) program was directed toward interfacing intelligent software to a real-world power distribution system. As a result, the APS has manifested itself as the brassboard, as the Autonomous Power EXpert (APEX) software, and as a load scheduler. The brassboard forms the distribution system with power components, loads, and fault circuits. The intelligent software program, APEX, reliably monitors key brassboard parameters and diagnoses faults. APEX, through either an operator or its autonomous functions, can reconfigure the brassboard for safe operation. The load scheduler attempts to maximize energy usage and provide APEX with current load configuration information.

The brassboard has become an invaluable tool for evaluating AI software as the control media of a power distribution system. Of course, as the hardware is refined and expanded, the AI software will gain further validation and operational history, which is the goal of the APS program.

ACKNOWLEDGMENTS

The author wishes to acknowledge the following individuals for their contributions to the brassboard's development: Walt Krawczonek, senior hardware engineer, for providing technical hardware leadership and system integration; Mark Ringer for his development of the scheduler; Todd Quinn for his expert system work and APEX; and Gene Liberman for his Ada code modifications which run on the 8086 controllers. As well, a note of thanks is owed to NASA Lewis's Space Station Freedom Development Branch. They provided software used for brassboard control, as well as hardware consultation and assistance during the brassboard's initial startup. The author is also grateful to Jim Kish for his technical and project leadership.

This work was done under contract NAS3-25266 with Jim Kish as coordinator.

REFERENCES

1. Billings, W.W.; Fox, D.A.; and Wagoner, R.G.: Power Management Equipment for Space Applications: SAE Paper 861621, 1986.
2. Beach, R.F., et al.: Evaluation of Power Control Concepts Using the PMAD Systems Testbed—Power Management and Distribution. IECEC-89; Proceedings of the Twenty-Fourth Intersociety Energy Conversion Engineering Conference, W.D. Jackson and D. Hull, eds., IEEE, 1989, Vol. 1, pp. 327-332.
3. Wright, T.; Mackin, M.; and Gantose, D.: Development of Ada Language Control Software for the NASA Power Management and Distribution Test Bed. IECEC-89; Proceedings of the Twenty-Fourth Intersociety Energy Conversion Engineering Conference, W.D. Jackson and D. Hull, eds., IEEE, 1989, Vol. 1, pp. 321-325.
4. Ringer, M.J.; and Quinn, T.M.: Autonomous Power Expert System. IECEC-90; Proceedings of the Twenty-Fifth Intersociety Energy Conversion Engineering Conference, P.A. Newton, W.W. Schertz, and R.H. Till, eds., American Institute of Chemical Engineers, New York, 1990, Vol. 1, pp. 278-283.

5. Quinn, T.M.; and Walters, J.L.: Autonomous Fault Detection, Isolation, and Recovery System for a 20 kHz Electric Power Distribution Test Bed. NASA TM-104344, 1991.
6. Ringer, M.J.: Autonomous Power System: Integrated Scheduling. Presented at the Operations, Applications and Research Symposium, Houston, Texas, July 1991.

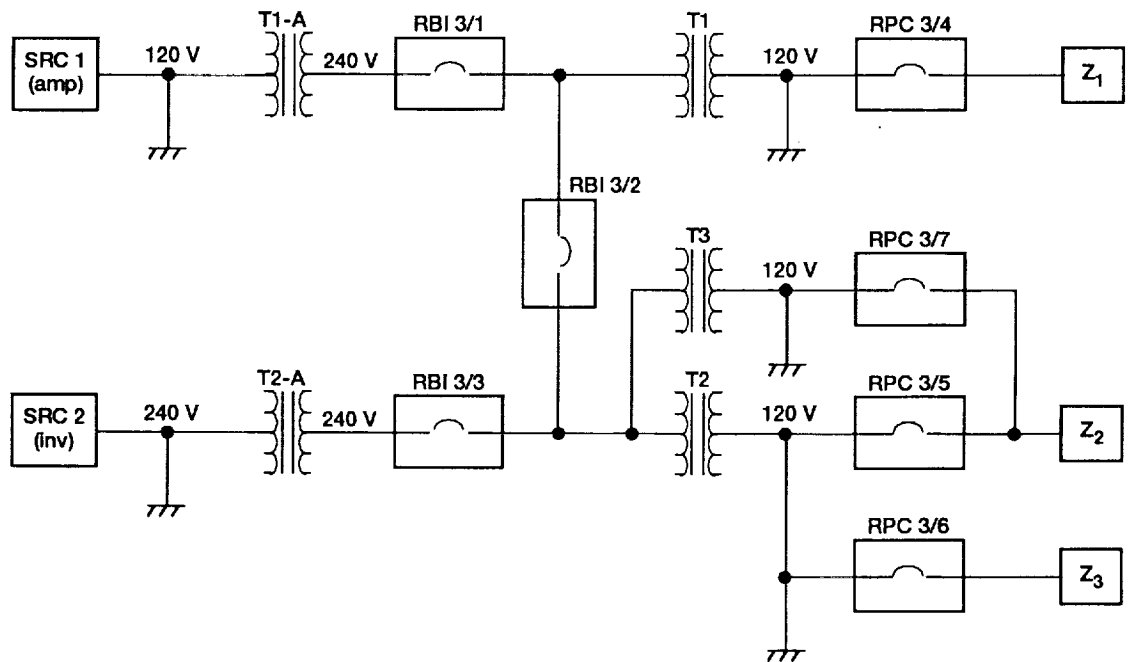

Figure 1.—Autonomous Power System (APS) brassboard one-line diagram.

Legend

- Ethernet
- - - RS-232
- 1553 B

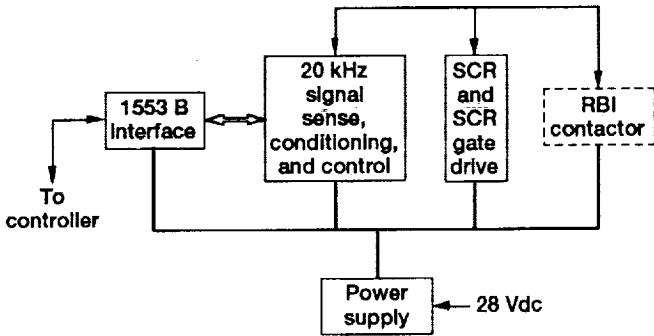

Figure 2.—Basic functional circuits used for each remote power controller (RPC) and remote bus isolator (RBI), including the RBI's contactors.

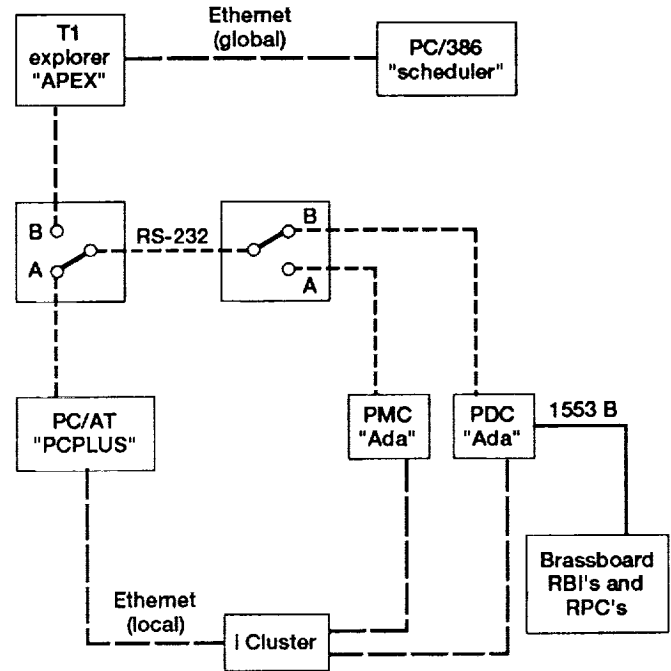

Figure 3.—Brassboard control elements, interfaces, and software.

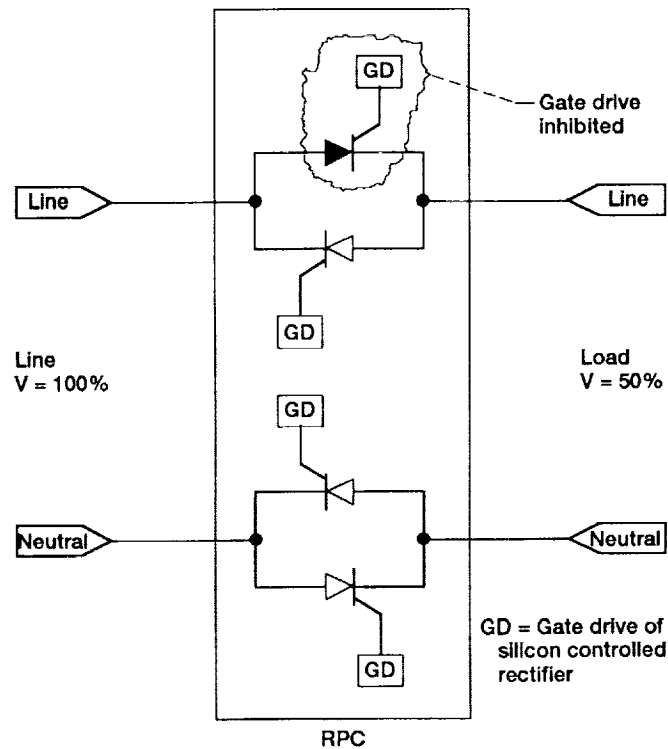

Figure 4.—Inhibited remote power controller SCR gate drive, and reduced voltage.



REPORT DOCUMENTATION PAGE

Form Approved
OMB No. 0704-0188

Public reporting burden for this collection of information is estimated to average 1 hour per response, including the time for reviewing instructions, searching existing data sources, gathering and maintaining the data needed, and completing and reviewing the collection of information. Send comments regarding this burden estimate or any other aspect of this collection of information, including suggestions for reducing this burden, to Washington Headquarters Services, Directorate for Information Operations and Reports, 1215 Jefferson Davis Highway, Suite 1204, Arlington, VA 22202-4302, and to the Office of Management and Budget, Paperwork Reduction Project (0704-0188), Washington, DC 20503.

1. AGENCY USE ONLY (Leave blank)	2. REPORT DATE October 1992	3. REPORT TYPE AND DATES COVERED Final Contractor Report	
4. TITLE AND SUBTITLE Autonomous Power System Brassboard		5. FUNDING NUMBERS WU-590-12-33 C-NAS3-25266	
6. AUTHOR(S) Anthony Merolla			
7. PERFORMING ORGANIZATION NAME(S) AND ADDRESS(ES) Sverdrup Technology, Inc. Lewis Research Center Group 2001 Aerospace Parkway Brook Park, Ohio 44142		8. PERFORMING ORGANIZATION REPORT NUMBER E-6822	
9. SPONSORING/MONITORING AGENCY NAMES(S) AND ADDRESS(ES) National Aeronautics and Space Administration Lewis Research Center Cleveland, Ohio 44135-3191		10. SPONSORING/MONITORING AGENCY REPORT NUMBER NASA CR-189115	
11. SUPPLEMENTARY NOTES Project Manager, James A. Kish, Power Technology, NASA Lewis Research Center, (216) 433-6288. Anthony Merolla, Sverdrup Technology, Inc., Lewis Research Center Group, 2001 Aerospace Parkway, Brook Park, Ohio 44142 (work funded by NASA Contract NAS3-25266).			
12a. DISTRIBUTION/AVAILABILITY STATEMENT Unclassified - Unlimited Subject Categories 33 and 60		12b. DISTRIBUTION CODE	
13. ABSTRACT (Maximum 200 words) The Autonomous Power System (APS) brassboard is a 20 kHz power distribution system which has been developed at NASA Lewis Research Center, Cleveland, Ohio. The brassboard exists to provide a realistic hardware platform capable of testing artificially intelligent (AI) software. The brassboard's power circuit topology is based upon a Power Distribution Control Unit (PDCU), which is a subset of an advanced development 20 kHz electrical power system (EPS) testbed, originally designed for Space Station Freedom (SSF). The APS program is designed to demonstrate the application of intelligent software as a fault detection, isolation, and recovery methodology for space power systems. This report discusses both the hardware and software elements used to construct the present configuration of the brassboard. The brassboard power components are described. These include the solid-state switches (herein referred to as switchgear), transformers, sources, and loads. Closely linked to this power portion of the brassboard is the first level of embedded control. Hardware used to implement this control and its associated software is discussed. An Ada software program, developed by Lewis Research Center's Space Station Freedom Directorate for their 20 kHz testbed, is used to control the brassboard's switchgear, as well as monitor key brassboard parameters through sensors located within these switches. The Ada code is downloaded from a PC/AT, and is resident within the 8086 microprocessor-based embedded controllers. The PC/AT is also used for smart terminal emulation, capable of controlling the switchgear as well as displaying data from them. Intelligent control is provided through use of a TI Explorer and the Autonomous Power EXpert (APEX) LISP software. Real-time load scheduling is implemented through use of a "C" program-based scheduling engine. The methods of communication between these computers and the brassboard are explored. In order to evaluate the features of both the brassboard hardware and intelligent controlling software, fault circuits have been developed and integrated as part of the brassboard. A description of these fault circuits and their function is included. The brassboard has become an extremely useful test facility, promoting artificial intelligence (AI) applications for power distribution systems. However, there are elements of the brassboard which could be enhanced, thus improving system performance. Modifications and enhancements to improve the brassboard's operation are discussed.			
14. SUBJECT TERMS Brassboard; Ada; APEX; Switchgear		15. NUMBER OF PAGES 12	
		16. PRICE CODE A03	
17. SECURITY CLASSIFICATION OF REPORT Unclassified	18. SECURITY CLASSIFICATION OF THIS PAGE Unclassified	19. SECURITY CLASSIFICATION OF ABSTRACT Unclassified	20. LIMITATION OF ABSTRACT