

IN-08
136208
P.45

NASA
Technical
Paper
3270

December 1992

Simulator Evaluation of Displays for a Revised Takeoff Performance Monitoring System

David B. Middleton,
Raghavachari Srivatsan,
and Lee H. Person, Jr.

(NASA-TP-3270) SIMULATOR
EVALUATION OF DISPLAYS FOR A
REVISED TAKEOFF PERFORMANCE
MONITORING SYSTEM (NASA) 45 p

N93-15366
Unclas

H1/08 0136208



**NASA
Technical
Paper
3270**

1992

Simulator Evaluation of Displays for a Revised Takeoff Performance Monitoring System

David B. Middleton
*Langley Research Center
Hampton, Virginia*

Raghavachari Srivatsan
*ViGYAN, Inc.
Hampton, Virginia*

Lee H. Person, Jr.
*Langley Research Center
Hampton, Virginia*



National Aeronautics and
Space Administration
Office of Management
Scientific and Technical
Information Program



Summary

Cockpit displays for a Takeoff Performance Monitoring System (TOPMS) have been developed to provide pilots with graphic and alphanumeric information pertinent to their decision to continue or abort a takeoff. This information is presented to the pilots on panel-mounted head-down electronic display screens and on out-the-window projected head-up displays (HUD's). The runway scene and both displays are in color, but they are not dependent upon it. The head-down displays (HDD's) consist of a runway graphic overlaid with symbolic status and situation and advisory information including (1) the current position and airspeed, (2) the predicted locations on the runway for reaching decision speed V_1 and rotation speed V_R , (3) a ground-roll-limit line (GRL) for reaching V_R , (4) the predicted stop point (in the case of an abort), (5) the engine-status flags and measured engine-pressure-ratio (EPR) linear bars (for each engine), and (6) an overall Situation Advisory Flag (SAF) that recommends either continuation or rejection of the takeoff. The TOPMS HUD provides similar information, but it is in a simpler form.

In the present study, 17 multiengine-rated pilots, working as two-person crews, evaluated the TOPMS displays in the real-time Transport Systems Research Vehicle (TSRV) Simulator for the Boeing 737 airplane at the Langley Research Center. Both pilots had HDD's on their instrument panels, but only the pilot who was controlling the airplane during the takeoff had a HUD. The HDD's were rated "good," and the HUD's were rated "very good." The pilots commented that the HUD enhanced their situational awareness, even though they only focused on it for tracking airspeed or when some anomaly caused a sudden change in the display symbology (e.g., when an engine failed). The pilots further commented that the HUD symbology did not mask any important visual-scene cues and that it, in fact, provided an extra guidance cue for steering the airplane to (or parallel to) the runway centerline.

Based on the comments and ratings of the evaluation pilots, it was concluded that the TOPMS is a desirable and appropriate system for use by the pilots during the takeoff roll. All the evaluation pilots expressed a desire to have at least a TOPMS HDD in their cockpit because it provided valuable safety-related information not currently available during takeoff. The pilots also preferred to have the TOPMS HDD located closer to their line of sight out the front window (i.e., located higher on the instrument panel), but they considered its location on the navigation display screen to be acceptable.

Introduction

Current flight management systems generally do not monitor aircraft performance during takeoff (ref. 1). However, statistics compiled over the years indicate that accidents during the takeoff phase account for approximately 10 percent of all aircraft-related accidents. Since 1983, according to the National Transportation Safety Board (NTSB), 4220 accidents have occurred during takeoff, thereby killing 1378 people. Among large airliners, 8.7 percent of all flight accidents occurred during takeoff. Among regional airliners, the rate has been approximately 12.5 percent (ref. 2).

Most takeoff-related accidents are attributable to some form of performance degradation, and a large percentage of these accidents could have been avoided if a simple, comprehensive way had existed to monitor the progress of the airplane's takeoff roll (ref. 1). Several performance monitoring systems of various complexities, such as single-point speed checks (ref. 3) and elapsed time to reach a point on the runway (ref. 1), have been proposed. Also, a multiparameter aircraft performance-margin indicator (ref. 4) that continuously determines the ability of the airplane to achieve rotation speed V_R and to brake to a stop within pertinent aircraft and runway constraints has been conceived. This indicator does not, however, directly indicate where on the runway the airplane will reach V_R or where the stop point will be, but it does show the pilots how near they are to losing either their abort or takeoff options (based on changing to maximum thrust for the remainder of the takeoff).

A multiparameter algorithm providing both focused and distributed takeoff advisory information has been formulated and verified by Srivatsan et al. (ref. 5) and Srivatsan and Downing (ref. 6). Subsequently, a head-down display (HDD) for the Takeoff Performance Monitoring System (TOPMS) was designed and evaluated (refs. 7 and 8) on the real-time Transport Systems Research Vehicle (TSRV) Simulator for the Boeing 737 airplane at Langley Research Center (hereafter called the TSRV B-737 Simulator). The TOPMS displays were evaluated by 32 multiengine-rated NASA, U.S. Air Force, airline, and industry pilots. The pilots rated the system "good," and they said it provided valuable performance and status information that was not currently available in the cockpit. They also suggested some changes and recommended further testing.

The purpose of the present study was to improve the TOPMS HDD developed in the reference 8 study to add a compatible head-up display (HUD) and to

investigate pilot acceptance of the TOPMS symbology in terms of usability, credibility, and appropriateness for the task. This report augments reference 8. Neither study addressed such issues as software validation, fault tolerance, or effects of bias signal errors or noise. However, extensive error and failure-mode analyses were conducted when the algorithm was being developed (refs. 5 and 6). The results of that effort indicated that distance predictions made by the TOPMS were generally within 5 percent of the actual distances computed during batch-simulated takeoffs and aborts. The algorithm, which was shown to be quite sensitive to wind errors and moderately sensitive to temperature and weight errors, contained the unique capability of determining and adjusting for unrealistic friction-coefficient estimates, accelerometer bias, and scale-factor errors. A wind estimator was added prior to the reference 8 study.

This paper describes the development of combined TOPMS head-up and head-down cockpit displays and documents a pilot-in-the-loop evaluation of them using the fixed-base, real-time TSRV B-737 Simulator. In the sections that follow, the TOPMS algorithm is briefly described, the display format and symbology are explained, the simulator and piloted simulation are described, and the results of the evaluation of the TOPMS displays are presented and discussed. Because the HDD's in this study are similar to those shown in reference 8, most of the photographs shown herein will be of the TOPMS HUD's. For monitoring purposes, the position of the airplane is assumed to be located at the tip of the nose of the airplane symbol.

Nomenclature

CAS	calibrated airspeed
c.g.	center of gravity
CRT	cathode-ray tube
EO	engine out (denoted as E.O. in appendix A); engine is underperforming or overperforming by more than some amount (e.g., 15 percent in this study)
EPR	engine pressure ratio
GROLL	ground-roll-limit line; initiating takeoff beyond this line is not recommended
HDD	head-down display
HUD	head-up display

NASA	National Aeronautics and Space Administration
NCDU	Navigation Control Display Unit
ND	Navigation Display
PD	Primary Display
PR	pilot rating
RFL	reference field length (amount required for takeoff under existing conditions)
SAF	Situation Advisory Flag ("GO" or "NO-GO" advice)
s_0, \dots, s_3	incremental distances on runway (fig. 2)
TOPMS	Takeoff Performance Monitoring System
TSRV	Transport Systems Research Vehicle (Boeing 737 class)
V_1	decision speed; airspeed limit at which pilot should opt to continue the takeoff or abort it
V_2	takeoff climb speed (denoted as V_2 in figs. 5 and 8); V_2 is 120 percent of stall speed
V_R	rotation speed; pilot initiates rotation upon reaching this speed
μ_r	rolling-friction coefficient

Description of System

Algorithm

The TOPMS algorithm consists of two main parts: a pretakeoff segment and a real-time segment, as shown by the block diagram in figure 1. The pretakeoff segment calculates the airplane-trim values, the nominal performance parameters, and a reference field length (RFL) which is approximately the minimum runway length required for a takeoff/abort under the existing conditions and a predetermined V_1 . The real-time segment assesses takeoff progress and system status based on the measured performance and the precalculated nominal performance. This segment also computes the parameter values that drive the displays.

The pretakeoff segment uses detailed engine, aerodynamic, and landing-gear models in conjunction with a typical takeoff throttle-movement history to generate a set of nominal airplane performance values (ref. 6). To do this, the algorithm requires inputs from the parameters that are specified in table 1.

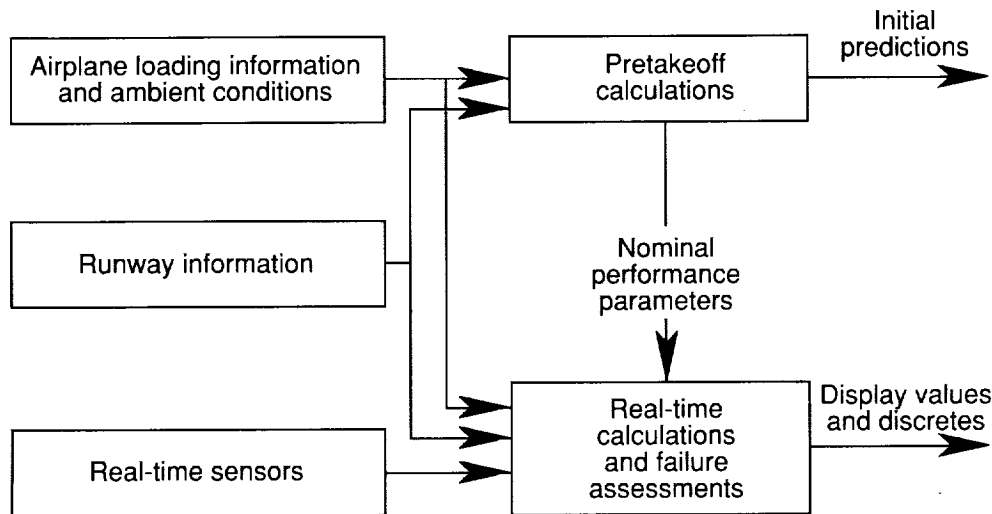

Figure 1. Block diagram of TOPMS algorithm functions.

(The runway slope was set to zero, so it was not a factor in this study.) These inputs are entered either manually (via keyboard) by the pilots or input automatically by appropriate onboard systems.

Table 1. Inputs for TOPMS Pretakeoff Segment

Airplane center of gravity
Airplane gross weight
Airplane flap setting
Ambient temperature
Pressure altitude
Wind direction
Wind speed
Rolling-friction coefficient
Runway length
Runway offset

The pretakeoff segment computes (1) the runway distance s_0 required to reach decision speed V_1 , (2) the runway distance s_3 required to bring the airplane to a complete stop from V_1 , (3) the runway distance s_1 required to reach rotation speed V_R from V_1 with one engine failed, and (4) the ground-air distance s_2 required to attain a height of 35 ft at the departure end of the runway after experiencing an engine failure at V_1 . These distances are shown in figure 2 for the case in which s_3 is less than $s_1 + s_2$.

The initial ground-roll distance s_0 from the brake-release point to the point where the engine failure occurs (plus the greater of $s_1 + s_2$ or s_3) constitutes the RFL metric. A ground-roll-limit distance to reach V_R then is computed by subtracting s_2 from the total runway length.

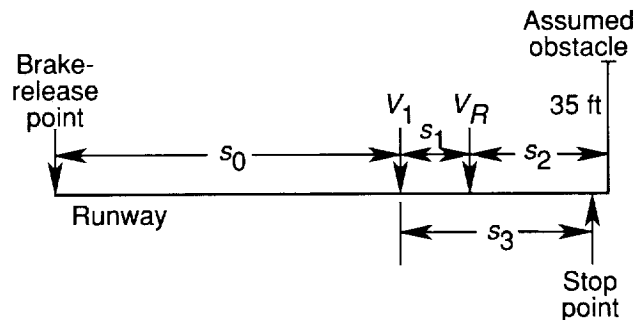

Figure 2. Incremental runway distances.

After the pretakeoff computations are complete, the pilot enters the length of the assigned runway and the distance from the threshold to the position where the takeoff roll will begin (i.e., initial “runway offset”). The algorithm then rescales and adjusts the runway graphic and associated symbology to span the full vertical range of the display screen. The algorithm also generates a set of nominal performance values for the upcoming takeoff based on aircraft loading, ambient conditions, and estimated runway rolling-friction coefficient μ_r .

During the takeoff roll, the algorithm accepts the measured inputs listed in table 2 and continually calculates the present position of the airplane on the runway, the runway distance needed to achieve rotation speed, and the runway distance needed to bring the airplane to a complete stop. After waiting (3 sec in this study) for the engine dynamics (which are due to throttle movement) to stabilize, the runway μ_r and the nominal performance values are recomputed.

This computational feature is unique because it can be performed several times (e.g., when the runway is partly dry and partly slushy); however, in this study, the recalculation was only performed once. The real-time segment also monitors the "health" (e.g., EPR) of the engines.

Table 2. Measured Inputs for Real-Time Segment

Airplane flap setting
Left and right throttle positions
Left and right engine pressure ratios
Airplane calibrated airspeed
Airplane accelerations
Airplane ground speed

Display Format and Symbology

Figure 3 shows the locations of the TOPMS head-up and head-down displays in the TSRV B-737 Simulator cockpit. The graphic for the simulated HUD was generated in real time, displayed on a monitor, video-photographed, and concurrently mixed electronically with the real-time video signal of the airport/runway scene. Consequently, the HUD graphic was somewhat "fuzzy," but the pilots declared it adequate for the study. The HDD graphic appears on the Navigation Display (the lower of the two square electronic screens in the lower center of fig. 3). At liftoff, the HUD graphic disappears, whereas the HDD graphic is replaced by appropriate maps and other navigation data.

The Primary Display (PD), located just above the Navigation Display, contains attitude, altitude, and control-command information. The pilot transitioned to this display after liftoff to set up the climb maneuver (which was partially performed, but was not included in the scope of this study).

The TOPMS HDD consists of a runway graphic outline with passive and active symbology superimposed over and around it. This symbology is illustrated in figure 4(a) for both takeoff and abort. (The symbology for the HUD is shown in fig. 4(b).)

The left side of figure 4(a) shows a symbol indicating that the airplane on a 6000-ft runway is nearing V_1 (which is predicted to occur at the horizontal line labeled " V_1 line"). The two triangles along the centerline of the runway graphic indicate where V_R is predicted to occur. The apex of the unshaded triangle shows the initial or pretakeoff prediction and is thus stationary, whereas the apex of the shaded

triangle indicates the updated (real-time) prediction of where V_R will be reached. The V_R line tracks the apex of the shaded triangle if and whenever it is repositioned (updated). In a nominal ("no-error") takeoff roll, the two triangles remain superimposed.

The nose of the airplane symbol indicates the present longitudinal position of the airplane. The calibrated airspeed (CAS) of the airplane is shown digitally inside the box at the end of the line out to the left. The HDD's in this study contained a duplicate CAS box and line on the right side of the airplane. The RFL display was not photographed for this study. (Fig. 5 is from the ref. 8 study.) The CAS boxes move down the runway with the airplane symbol. By design choice, however, the airplane symbol does not move laterally.

Just beyond the shaded triangle, a ground-roll-limit line (GRLL) stretches across the runway graphic, thus representing the farthest recommended position down the runway for reaching V_R . Therefore, for a "satisfactory" takeoff, the shaded triangle should not be allowed to cross this line.

Engine flags are arbitrarily located at each end of the GRLL. These flags have two primary states: green for satisfactory and red for unsatisfactory operation (i.e., "failure"). On each side of the runway graphic just above the engine flags, linear bars extend forward parallel to the runway to indicate measured EPR for each engine. A target (or reference) tick mark shows where the top (forward end) of the bars should be for the existing set of conditions.

The large rectangle across the end of the runway, labeled "Situation Advisory Flag" (SAF), provides the pilots with their primary decision-advisory information. The TOPMS algorithm analyzes all information pertinent to the takeoff and summarizes its findings by displaying a particular flag size and color, as indicated in table 3.

Once an abort has been initiated, most of the takeoff-related information is removed from the screen, thus leaving a display similar to the one shown on the right side of figure 4(a). The airplane symbol and the "X" (the predicted stop point when using maximum braking) remain, but the CAS is replaced by the ground speed in the speed box. An additional symbol, shaped like an oval "football," appears near the end of the runway graphic to indicate the predicted stop point based on measured acceleration. In the case shown, less than full braking was being applied.

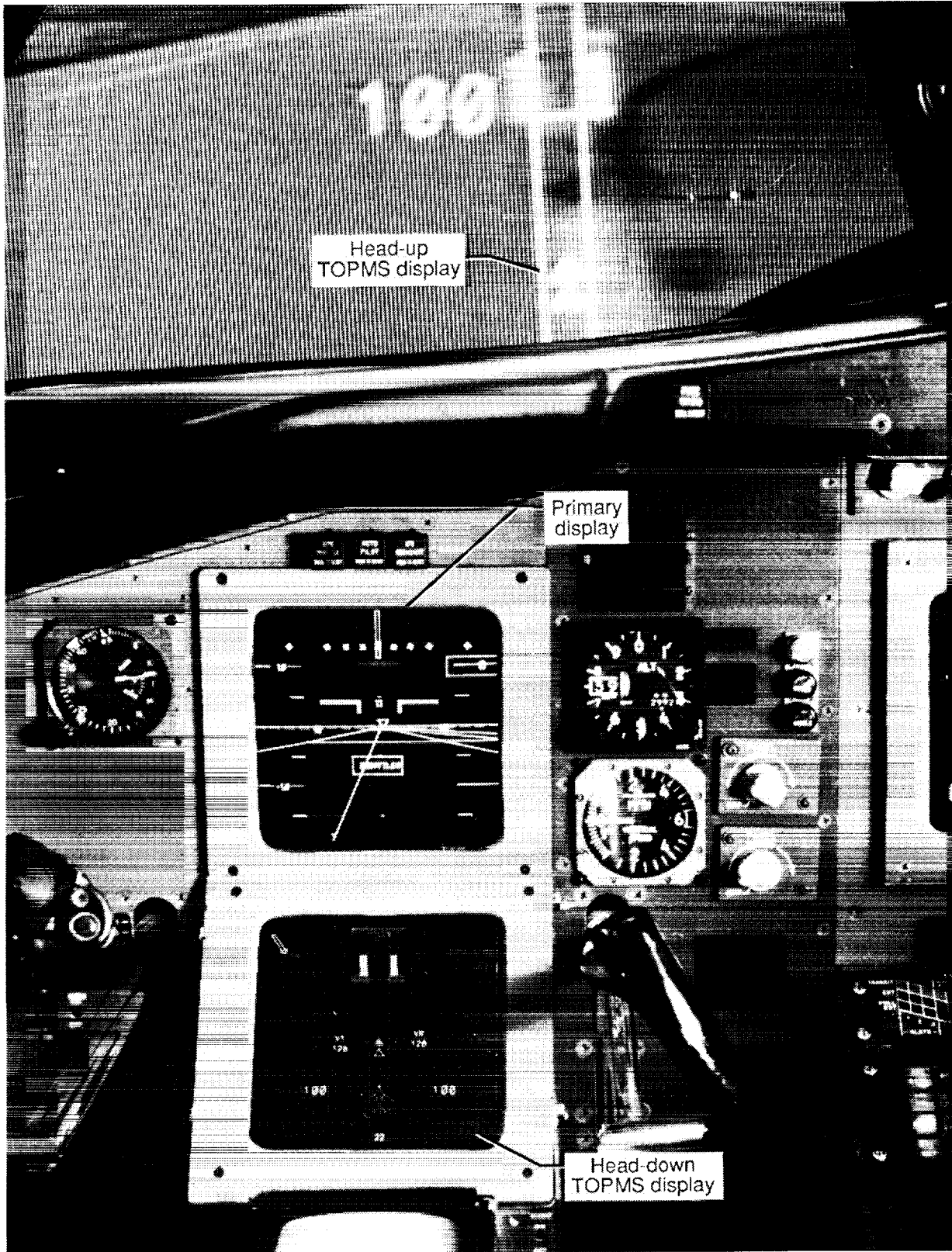

L-89-6440

Figure 3. Locations of pilot displays in TSRV B-737 Simulator.

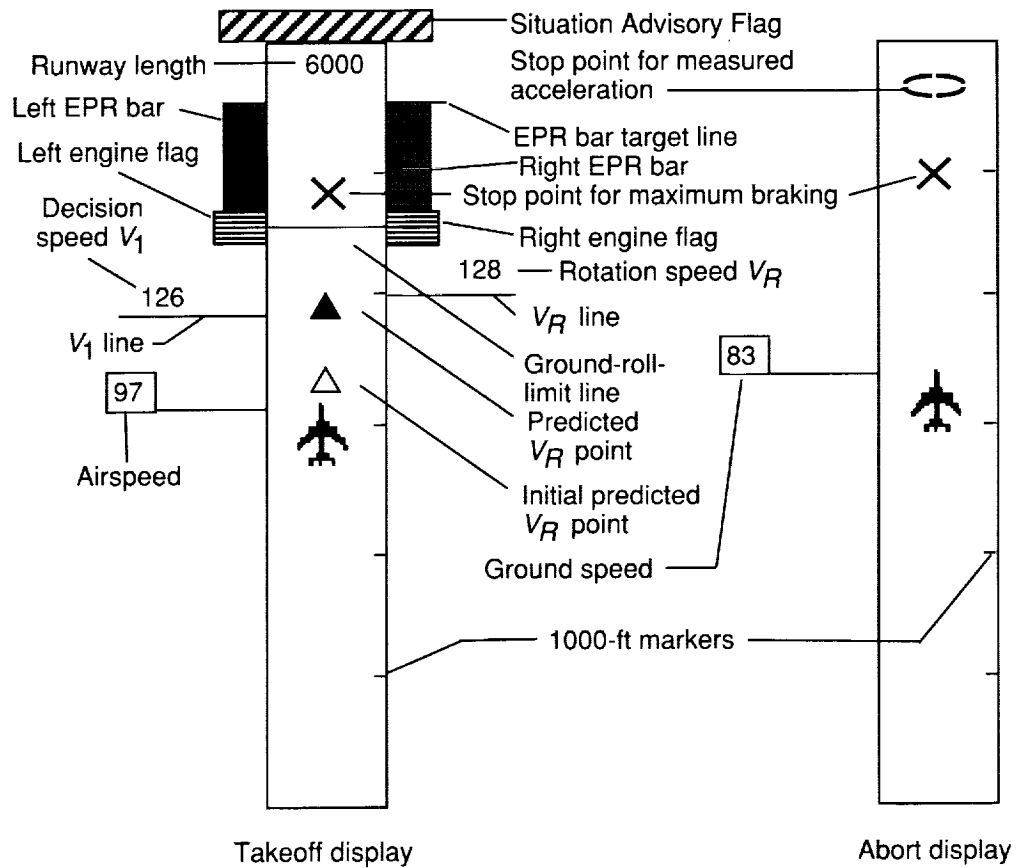

(a) Head-down displays.

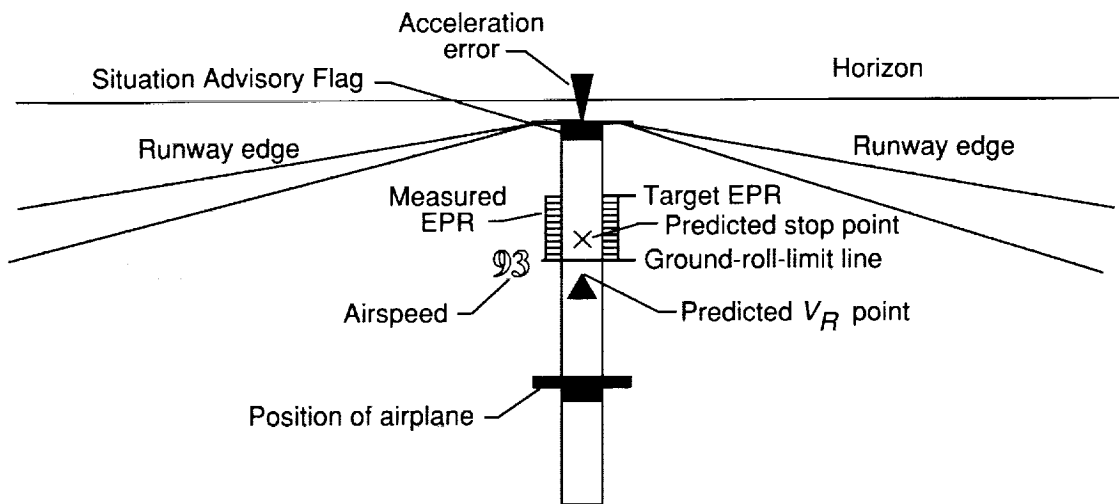

(b) Head-up display.

Figure 4. TOPMS display symbology.

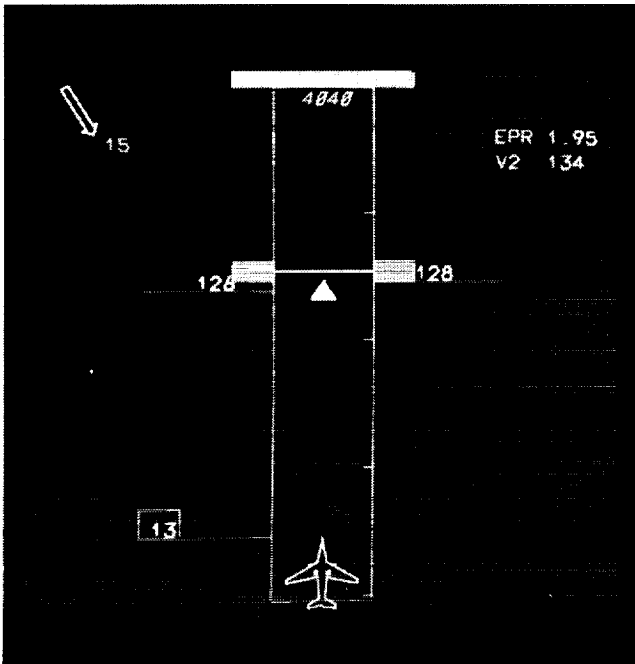

L-87-1141

Figure 5. TOPMS HDD showing typical RFL condition.

Table 3. Colors, Sizes, and Conditions for Situation Advisory Flags

Color and size ^a	Flight condition
Green	Takeoff roll proceeding satisfactorily No engines failed; airplane will attain V_R before reaching GRL, but it cannot stop on runway One engine failed at speed greater than V_1 ; airplane can attain V_R before reaching GRL, but it cannot stop on runway
Flashing amber ^b	One engine has failed at speed greater than V_1 ; airplane can reach V_R before reaching GRL, and it can stop on runway
Red	One engine failed at speed less than V_1 Both engines have failed Predicted rotation point beyond GRL Longitudinal acceleration is not within specified error band (e.g., 15 percent of nominal values computed by algorithm)

^aIn the HDD's, the SAF's were all twice as wide as the runway graphic. In the HUD's, the green SAF's were made the same width as the runway graphic; the amber SAF's were made twice as wide, and the red SAF's were made three times as wide as the runway graphic. Such widths permit identification of the flag if or when its color is not discernible.

^bIn the reference 8 study, the amber SAF was preferred by approximately one-half of the pilots; however, for completeness, it was shown on both the HDD and the HUD to the pilots in the current study.

The TOPMS HUD is similar to but somewhat simpler than the HDD, as shown in figure 4(b). An important addition to the HUD is an acceleration-error indicator, which is located at the far end of the runway symbol. When the acceleration error is less than 5 percent, the wedge-shaped pointer remains stationary; when the error is greater than 5 percent, it moves to the left for an acceleration deficiency and to the right for an acceleration excess.

At the completion of the pretakeoff calculations, the HDD comes up in a default mode, such as shown in figure 5. The runway graphic is scaled for the 4040-ft length shown at the far threshold. This length includes the RFL plus a 500-ft start-point offset. Note (from the tick marks indicating 1000-ft increments along the right edge of the runway) that the tip of the airplane symbol appears to be approximately 500 ft down the runway. The takeoff roll begins here.

Scheduled values for EPR and V_2 (denoted as V2 in fig. 5) are displayed in the upper right portion of the screen for reference. Also, the arrow and the numeral in the upper left represent the wind direction relative to the runway and the wind speed in knots. The number 13 in the box opposite the nose of the airplane symbol indicates the initial airspeed (i.e., approximately the head wind component of the wind vector).

Figure 6 shows the HUD for the same conditions used in figure 5. Figure 7 then shows the display after the dimensions for the actual length (5000 ft) of the assigned runway have been input into the algorithm. Note that the additional 960 ft appears to be inserted into the runway graphic between the performance triangle and the GRL.

Figure 8 shows the HDD for a case in which an airplane is far into its takeoff roll on a 7000-ft runway. This runway is oriented 220° from the North; hence, the number 22 is seen at the near threshold of the runway graphic. As shown in the CAS boxes to the left and right of the airplane symbol, the airspeed has reached 100 knots. (Duplication of the CAS box and line on the right side of the airplane symbol was recommended by the pilots in the earlier ref. 8 study.)

In figure 8, the shaded triangle and the V_1 and V_R lines have shifted forward to mark current predictions of where decision speed and rotation speed will occur. Measured EPR bars extend upward from the engine flags to a level considerably below the "scheduled" or nominal EPR = 1.95 level (indicated by the horizontal tick mark outside the runway graphic between the top of the bar and the SAF). The bottom of the EPR bar corresponds to an idle-thrust condition.

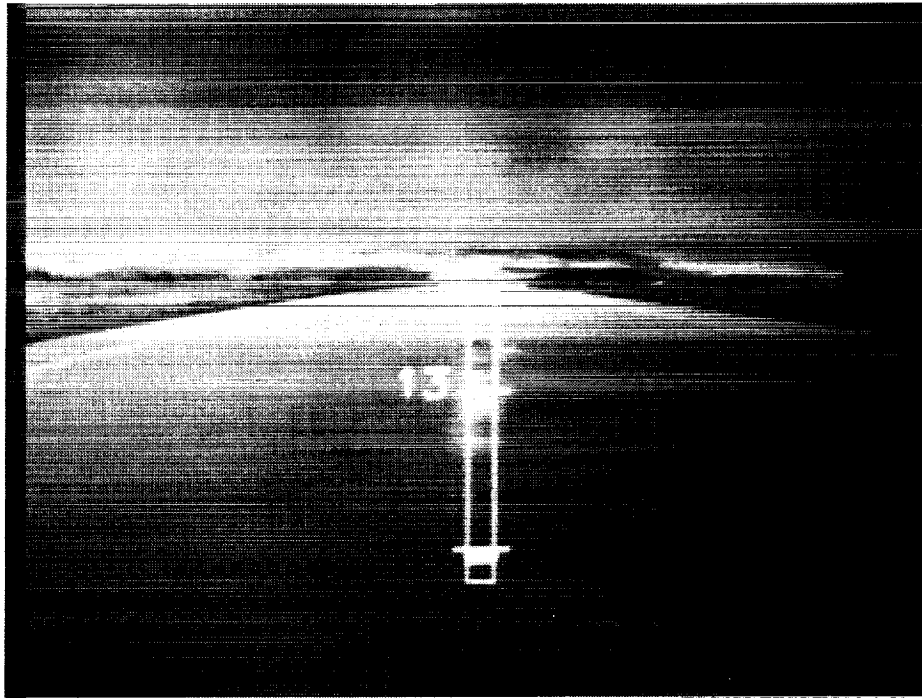

L-87-04555

Figure 6. TOPMS HUD showing typical RFL condition.

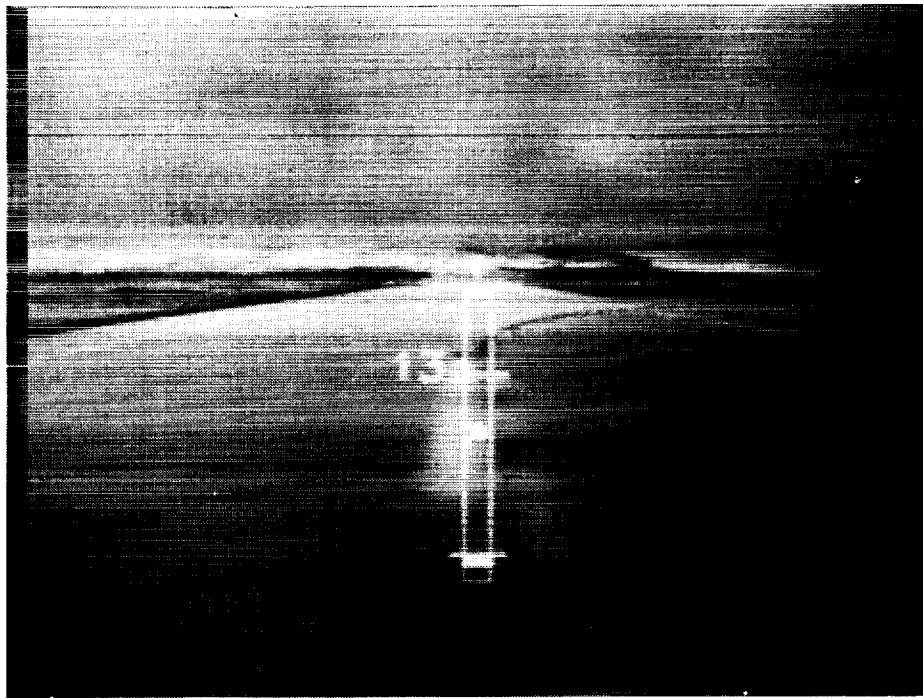

L-87-04553

Figure 7. TOPMS HUD after inputting actual runway length.

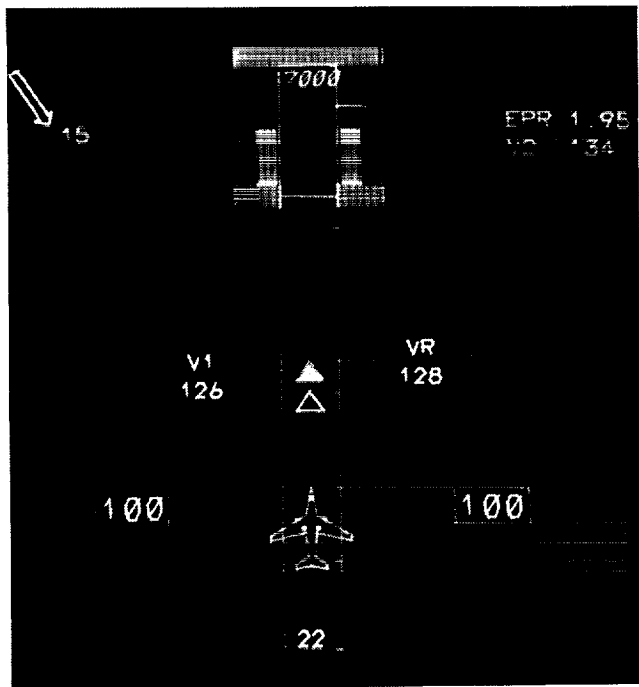

L-87-4566

Figure 8. TOPMS HDD showing below-nominal EPR.

The display indicates that the pilot did not advance the throttles to the scheduled level for a nominal takeoff. Engine-performance and/or acceleration-performance deficiencies can also cause an EPR bar to be low, but a deficiency of the magnitude shown in figure 8 would have triggered an abort flag. In the case shown, the TOPMS algorithm recommends a continuation of the takeoff; hence, the SAF at the end of the runway graphic is green. Note that the shaded triangle is still approximately 2000 ft from the GRLL.

Figure 9 shows the simpler HUD for this same situation. The airplane symbol is represented by a solid box with a horizontal line across the front of it; this line indicates the position of the airplane. The two triangles and the EPR bars are similar to those shown in the HDD, but the CAS boxes are replaced by a large numeral airspeed in knots (100), which is fixed near the center of the display. All other alphanumeric information is omitted.

The vertical wedge-shaped symbol at the end of the runway in figure 9 was a feature added to the HUD. This symbol indicates the level of measured acceleration with respect to a calculated nominal acceleration for the throttle setting being used. In the case shown in figure 9, the wedge remained horizontally centered on the end of the runway graphic because

the difference remained less than 5 percent, thus indicating that the engines were apparently operating properly at a reduced-level setting. In this scenario, the shaded triangle also would be expected to remain stationary at its displaced-forward position.

If a higher than scheduled throttle setting were to be used, the shaded triangle would move in the direction of the approaching airplane, as shown in figure 10.

An acceleration deficiency causes the wedge to move left as shown in figure 11. When this wedge reaches the end of the tolerance scale (15 percent used in this study), an abort-advisory flag is triggered similar to the one shown in figure 12. (For noticeability, the red abort flag in the HUD was made three times as wide as the green flag, so it extends beyond the end of the acceleration scale.) When the abort flag is triggered, an additional symbol ("X") also appears, and this symbol locates the predicted maximum-braking stop position. This position is updated in real time and recedes toward the far end of the runway as a function of current aircraft location, speed, and acceleration.

Figure 13 shows another abort situation; this time, the situation was due to a failed engine on the right side. The airspeed is 85 knots. The acceleration-deficiency wedge has shifted to the left, and the triangles have separated significantly. Here, the EPR bar on the right side has dropped noticeably and turned red, thus identifying the failed engine. This same EPR pattern occurs in the HDD; however, the width of the SAF flag remains constant for all colors (table 3).

Once an abort has been initiated (by rapidly pulling the throttles back to "idle"), the display converts to configurations similar to those shown in figure 14. All the takeoff-related symbology is erased, thus leaving only the airplane and the maximum-braking stop-point symbols. The airspeed numeral is replaced with a ground speed numeral and the new oval-shaped symbol (shaped similar to an oval football) has appeared. This symbol indicates the stop point based on measured acceleration. For the case shown in figure 14(a), less than maximum braking is being applied; therefore, the actual stop point will be beyond the "X" if this braking level is continued unchanged. In figure 14(b), full braking causes the two symbols to become superimposed, and in figure 14(c), the addition of reverse thrust drives the oval-shaped symbol slightly below the "X." The HUD converts similarly.

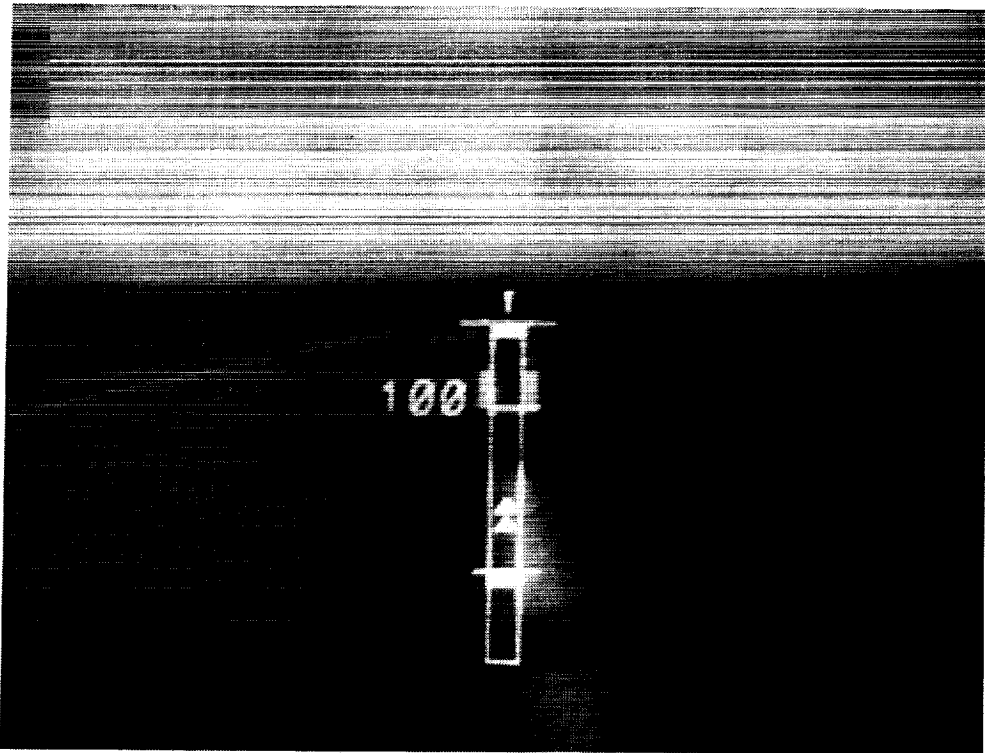

Figure 9. TOPMS HUD showing below-nominal EPR.

L-87-4563

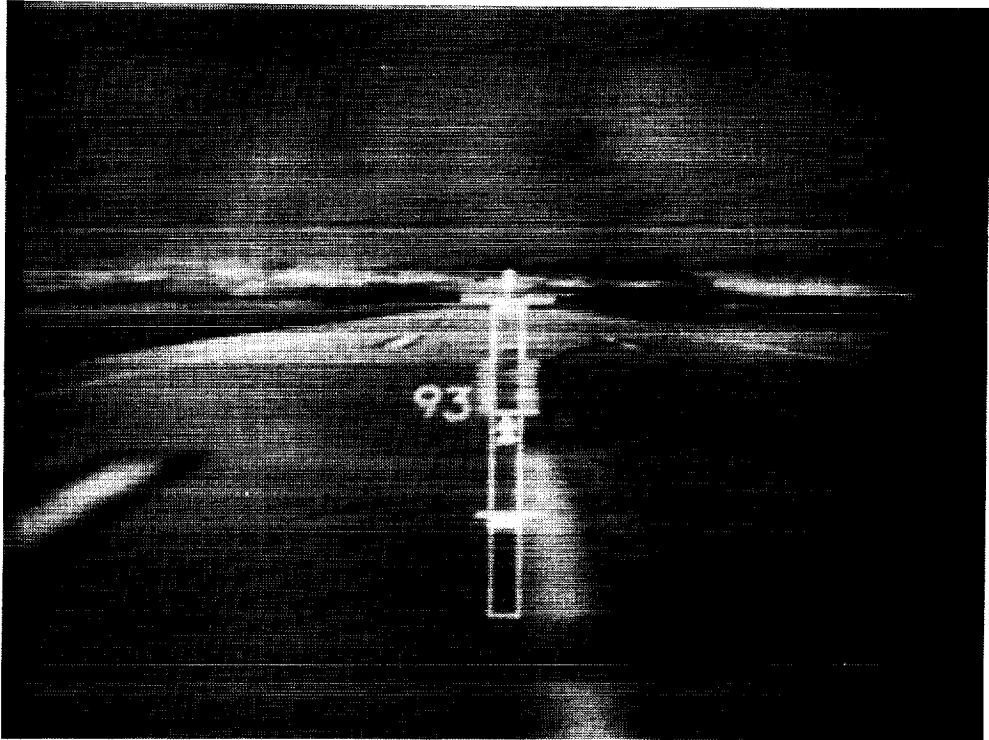
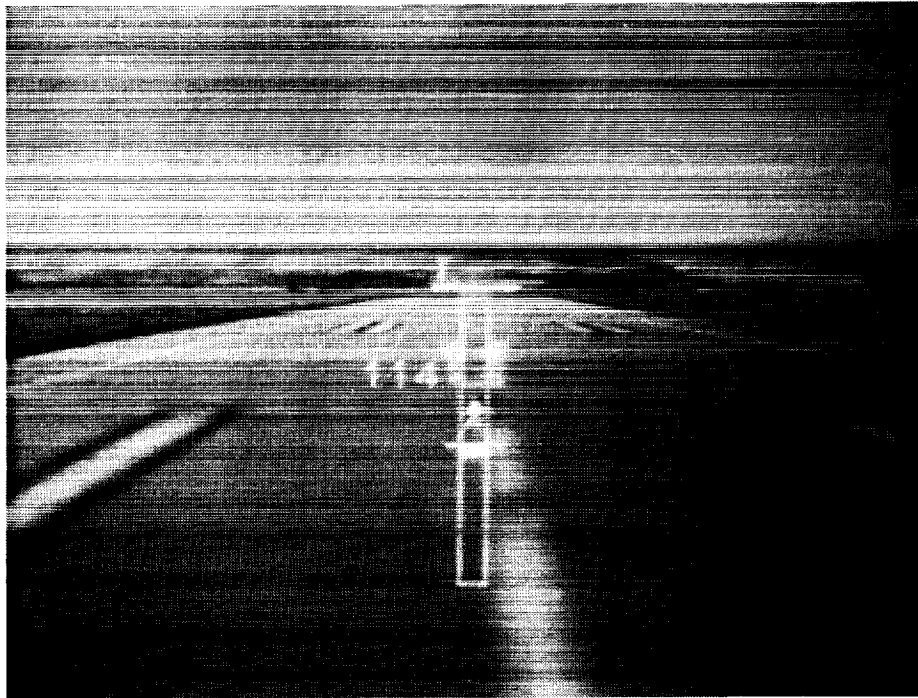

Figure 10. TOPMS HUD showing above-nominal EPR.

L-87-4564

ORIGINAL PAGE
BLACK AND WHITE PHOTOGRAPH



L-87-04559

Figure 11. TOPMS HUD showing large, but acceptable, acceleration error.

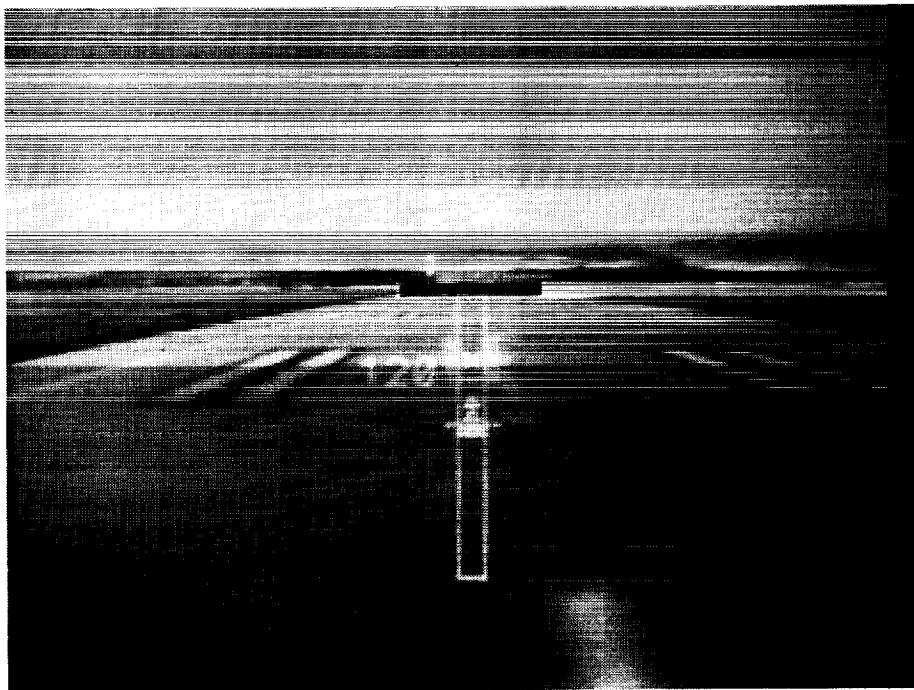

L-87-04561

Figure 12. TOPMS HUD showing unacceptable acceleration error.

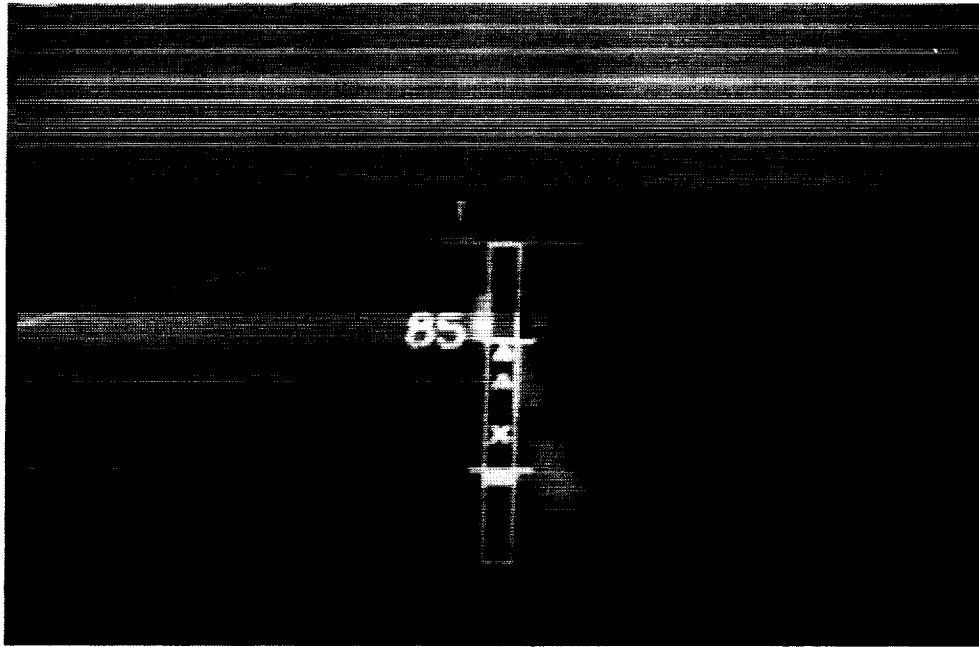

L-87-4565

Figure 13. TOPMS HUD for right-engine failure below V_1 .

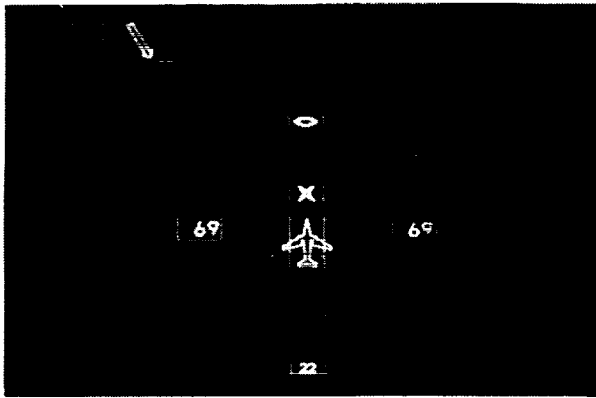

(a) Partial braking.

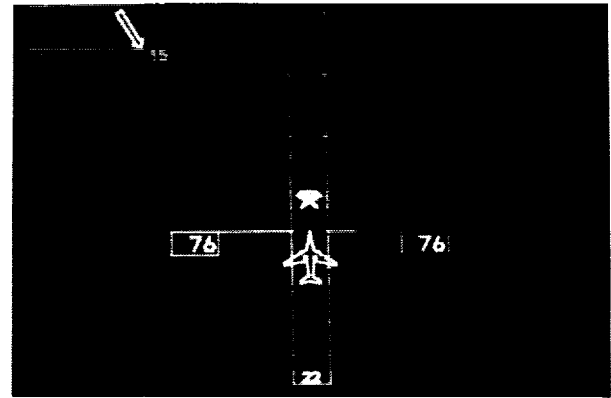

(b) Full braking without reverse thrust.

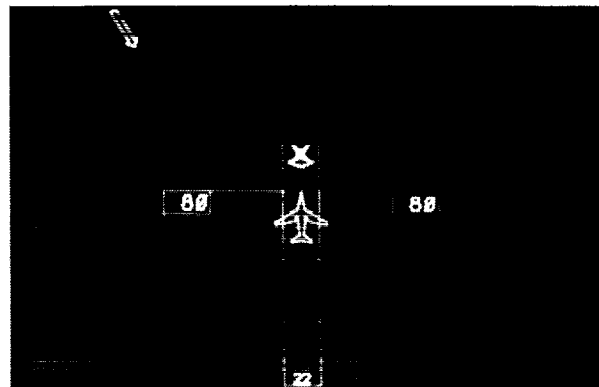

(c) Full braking including reverse thrust.

L-89-4496

Figure 14. Abort displays for three braking levels.

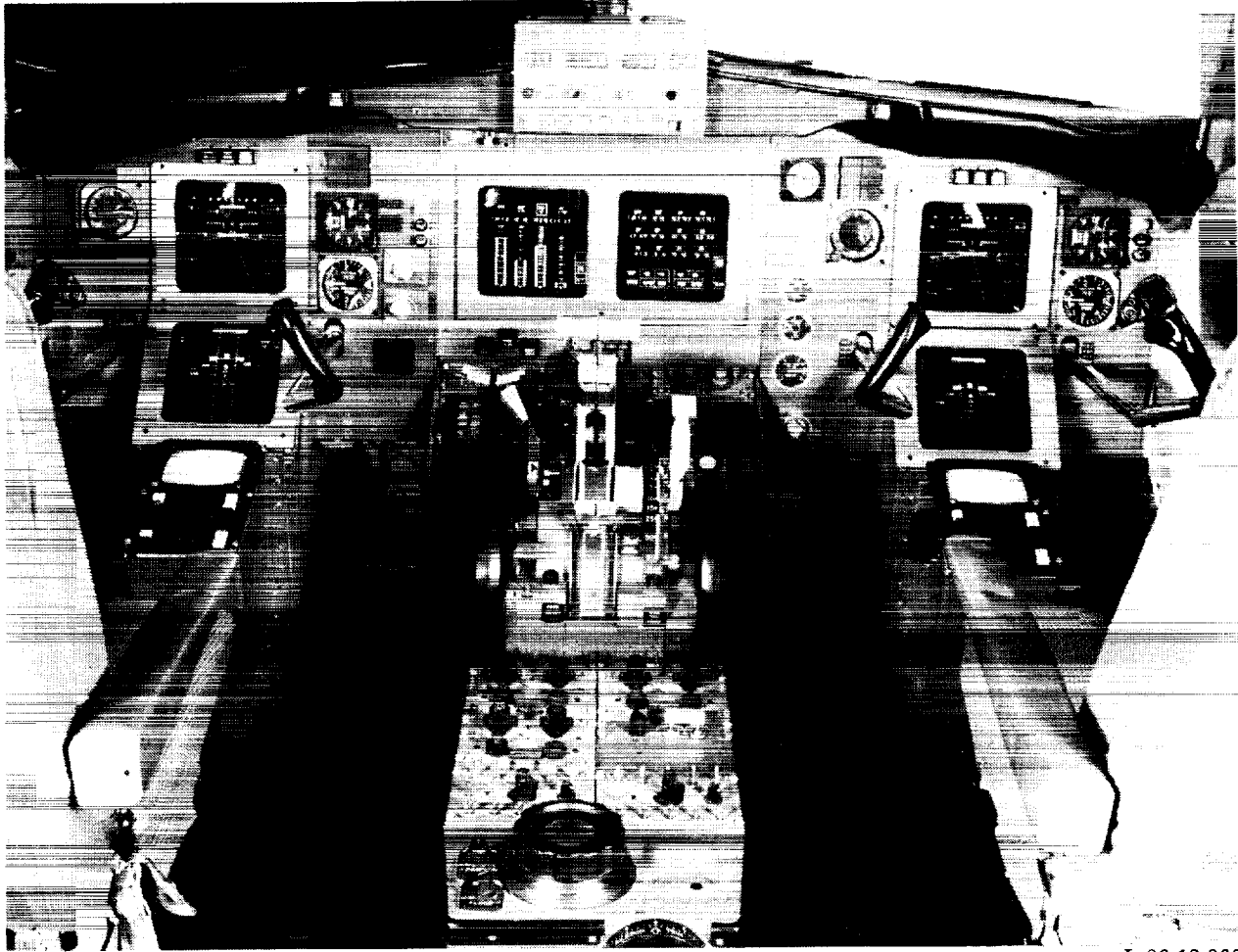

L-86-12,066

Figure 15. Flight deck of TSRV B-737 Simulator.

Description of Simulation

The TOPMS simulation is accomplished using a six-degree-of-freedom nonlinear model of the TSRV B-737 airplane; this simulation includes a detailed aerodynamic package, an engine model, and a landing-gear model. The aerodynamic package incorporates two- and three-dimensional table lookups for aerodynamic coefficients and adjusts them for ground effects. The engine model includes detailed ram-air and temperature effects. The landing-gear model provides for braking and steering.

TSRV Simulator Cockpit

Pilot interface to this simulation model is accomplished through a fixed-base replica (fig. 15) of the research flight deck of the TSRV B-737 airplane. This simulated cockpit incorporates most of the features found in the aft flight deck of the actual TSRV B-737 airplane (ref. 9). Each pilot has two CRT-type displays and a Navigation Control Display Unit

(NCDU) arranged in front of him or her. In addition, the pilots share a set of engine displays. (The CRT is on the center panel between them.) A simulated out-the-window runway scene shown in figure 3 (but not shown in fig. 15) was provided for the pilot in the left seat only. This is the background scene appearing in figures 6 and 7 and 9 to 13.

The upper CRT (located directly forward and just below the glare shield) is the Primary Display (PD), which contains attitude, altitude, and control-command functions. The Navigation Display (ND) below it normally displays maps, way-points, and other data used for airborne navigation. In this study, the ND also displayed the TOPMS information while the airplane was on the runway.

Below the ND is the NCDU. This unit consists of a small black and white CRT display and an alphanumeric keypad. The pilot uses this unit to enter navigation data and other information into the

flight computer; it also serves as the pilot's input device for TOPMS data.

TOPMS Operation

The TOPMS consists of two parts. The first part, the pretakeoff segment, is activated prior to the start of the actual takeoff roll. The pilot, using the NCDU, enters the information listed in table 1 and then activates the pretakeoff computations. Once these computations are complete, the ND screen produces a "default" TOPMS display similar to the one shown in figure 5. The HUD shows a similar graphic. The pilot then enters the actual runway length, and both displays are updated accordingly. The system is now ready for takeoff.

During the actual takeoff roll, the pilot who is flying (hereafter denoted as "pilot flying") moves the throttle to an intermediate setting, waits for the EPR to reach an associated intermediate value, and moves the throttles to approximately the recommended takeoff setting; the other pilot makes the final adjustments. When V_R is reached, the pilot pulls on the panel-mounted column (see fig. 3 for a closeup view) until the pitch attitude of the airplane reaches approximately 20° (as monitored on the PD); the pilot then returns the column to neutral. As the wheels lift off the runway, the TOPMS HUD disappears, and the HDD is replaced by selected map displays and other navigation information.

Evaluation

The TOPMS is being evaluated in several phases. The algorithm was analyzed and verified in batch simulation (ref. 6) for accuracy and sensitivity to various input parameters. Then, an initial TOPMS HDD was designed, tested, and rated (ref. 8) by more than 30 pilots (who had extensive multiengine experience) on the TSRV B-737 Simulator. Based on the comments and suggestions of these pilots, a HUD was incorporated, and the HDD's were revised as shown in figures 6 and 7 and 9 to 13. In the current study, these displays were used together and evaluated by using the same TSRV B-737 Simulator and appropriately revised rating criteria (fig. 16).

The real-time simulation sessions each involved two pilots working as a crew. The evaluation-pilot population for this study is shown in table 4. Most of the pilots had not met previously or worked together. Prior to coming to Langley Research Center, each pilot was mailed the briefing information shown in appendixes A and B. After arriving, the subject pairs

were given an oral briefing and shown a 10-min video concerning the operation of the TOPMS and the TSRV B-737 Simulator. The oral briefing included a review of the pilot-rating instructions contained in appendix A and an explanation of how to use the appendix B questions in conjunction with the rating diagram shown in figure 16. In particular, the pilots were instructed to observe and judge whether the displays clearly, realistically, and appropriately supported the airplane takeoff and abort tasks and whether they were credible in the sense that they complemented (without contradictions) information received from the other cockpit instruments or from the simulated visual runway scene. The evaluators also were asked to be aware of the mental work load level compared with what they normally experienced during a takeoff.

Table 4. TOPMS Evaluation Pilots

Pilot categories	Number of pilots
Air Force ^a	6
Airline ^b	7
American	
Delta	
Piedmont	
United	
Other ^c	4
Total . . .	17

^aEC-135 tanker pilots from Langley Air Force Base, Hampton, Virginia.

^bPilots provided by Airline Pilots Association (ALPA) Safety Office, Herndon, Virginia.

^cIncludes NASA and retired industry pilots.

After approximately three to five practice runs, the pilots executed a 2-hr program of takeoff and abort runs which included 1 hr (approximately 20 runs) as the pilot flying and 1 hr (approximately 20 runs) as the pilot not flying. During these practice runs, the pilots agreed on their division of duties and operating procedures (e.g., what speeds or events the pilot not flying would call out to the pilot flying). The runs covered the sets of conditions shown in table 5.

The runs were selected to exercise, as a minimum, all the flag conditions listed in table 3. Initially, the pilot pairs executed the full schedule of runs; then they reversed roles (and seats) and repeated approximately the same set of runs, but in a slightly different order. Usually run condition number 1 and parts of numbers 3, 5, and 9 (table 5) were not repeated.

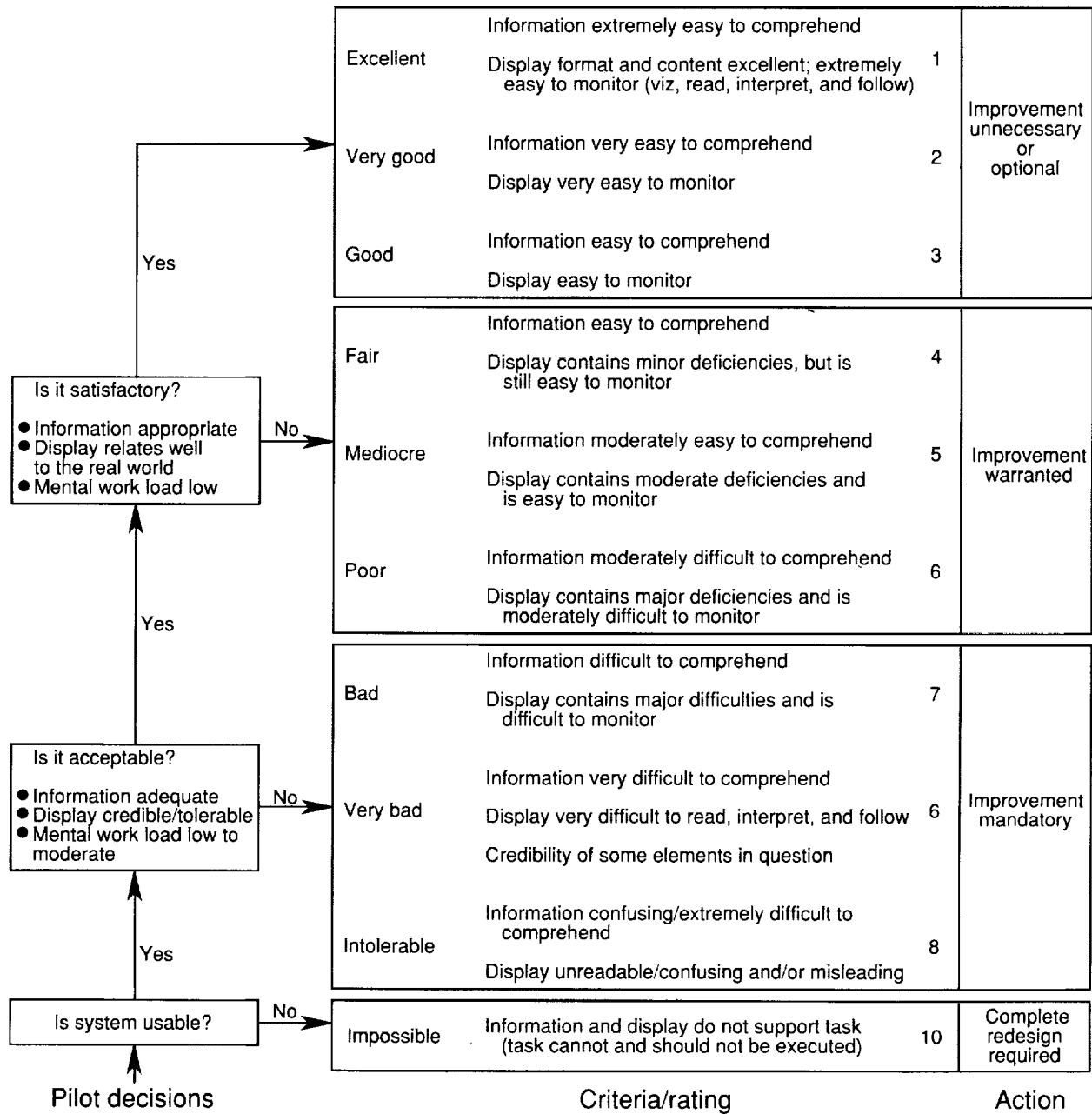

Figure 16. TOPMS displays rating diagram.

Table 5. Schedule of Run Conditions

1. Initial-condition errors prior to starting takeoff roll:
 - Runway too short (i.e., shorter than RFL)
 - Wrong flap setting
 - Out-of-range data entries
2. Normal takeoffs using nominal parameter values
3. Light, nominal, and heavy gross weights
4. Reduced-thrust takeoffs (throttles not advanced to nominal)
5. Ambient temperature conditions (32°, 75°, and 100°F)
6. Winds:
 - Nominal (15 knots at angle of 30° to runway)
 - Other choices (calm and 30 knots at angles of 0°, 15°, and 30° to runway)
 - Wind error (10 knots at angle of 30° from nominal)
7. Pressure altitudes (sea level and 5000 ft)
8. Rolling-friction coefficient:
 - For dry surfaces ($\mu_r = 0.015$)
 - Error conditions ($\Delta\mu_r = \pm 0.010$)
9. Runway lengths (RFL, 6000 ft (nominal), and 10000 ft)
10. Lighting situations:
 - Daylight, dusk, and dark conditions
 - Runway lights turned on for dusk and dark
11. Along-track acceleration errors (spoilers full-up for extra drag)
12. Engine failures at:
 - 80 knots airspeed on 6000-ft-long runway
 - V_1 on short runway (marginal room to stop)
 - V_1 on long runway
13. Several combinations of above conditions including the following:
 - Heavy airplane departing Denver (Altitude \approx 5000 ft) on 100°F day
 - Takeoffs under daylight, dusk, and dark conditions; runway lights turned on for dusk and dark situations

At the conclusion of a simulation session, each pilot was asked to independently evaluate the TOPMS by answering specific questions (including those listed in appendix C) about the content, ease of understanding, and usability of the displays and by using the figure 16 rating diagram, in conjunction with the appendix B questionnaires, to arrive at "goodness ratings" for both the HDD and the HUD. Examples of how to use the questionnaire (part 1 of appendix A) and the rating diagram (fig. 16) are given in appendix A. The rating diagram was patterned after the Cooper-Harper scale (ref. 10) by substituting display criteria for handling qualities criteria.

The appendix C list of questions was developed to prompt the pilots to comment freely and in detail

on the content and dynamics of the display symbology and how the displays might be used in a modern transport airplane. Each pilot was debriefed separately by a single interviewer who generally followed this list of questions so that all pilots were exposed to approximately the same basic debriefing questions.

The pilots were instructed in writing and verbally not to let factors such as unfamiliar controls and instrumentation or location of the TOPMS displays in the simulator cockpit influence their rating of the TOPMS displays. The pilots were, however, encouraged to comment on the compatibility of the TOPMS displays with existing instrumentation and to identify desirable or undesirable features of the overall simulation.

Results and Discussion

As previously mentioned, both solicited and unsolicited pilot comments and display ratings were obtained.

Pilot Opinions and Comments

In general, the pilots said they were impressed with the features of the TOPMS and would like to see this type of information available in their cockpits. During the simulation sessions and later in the debriefing interviews, they provided a number of useful comments and recommendations. The more significant responses are summarized and paraphrased in the following paragraphs to create generalized comments about the acceptability and usability of the displays and/or concerning the merits or faults of particular elements and features.

Comments on head-up displays. The pilots flying made the following comments (shown in italics) concerning the HUD. A brief discussion immediately follows each comment.

The TOPMS HUD enhances the normal visual information that is viewed through the forward windscreen. In particular, the HUD graphic concentrates the most useful performance and status information near the center of the pilots' forward look direction, and it does not mask any important visual cues that are available from the dynamic airport/runway scene.

Prior to the evaluation phase of this study, the HUD was conceived as a smaller, inset-type graphic that could be viewed through the upper-left part of the windscreen. However, during checkout trials, a decision was made to implement it in the center of the windscreen (superimposed on the "real" runway). Some of the initial pilot evaluators were asked if they would prefer that the HUD be reduced in size and/or moved to another location. None wanted it moved or made smaller; therefore, the HUD as shown in figures 6 and 7 and 9 to 13 remained unchanged throughout the evaluation study.

During normal takeoff rolls, the tendency is to "look through" the HUD graphic, except during engine spool-up (indicated symbolically by a linear "growth" of the EPR bars) and afterward to monitor airspeed. Primary awareness is of the runway edges and whether the airplane is being steered parallel to them and/or the centerline of the runway. Several pilots flying said they were subconsciously alert for movement or changes in the triangles, the EPR bars, and/or the acceleration-error pointer, but they did not dwell on any of them when everything seemed to be proceeding normally.

When a takeoff roll is proceeding normally, none of the TOPMS symbology moves appreciably except the airplane symbol and the airspeed numerals. In contrast, the visual runway scene (particularly the runway cracks and painted lines) is quite noticeable as it moves toward the pilots with increasing speed as the takeoff roll progresses.

After the first few runs, the tendency is to rely almost entirely on the airspeed numeral in the HUD, and once the throttles are set, little need exists to look back inside the cockpit at the conventional (round) airspeed dial.

The rationale of the pilots for this behavior was that unless airspeed information comes from two independent sources, additional effort (but very little additional insight) results from such dual monitoring. The pilots also expected that the pilots not flying would make appropriate cross-checks between airspeed on their regular round dials and the CAS in the speed box of their TOPMS HDD's. Thus, in general, the large airspeed numeral implemented in the HUD was considered a very useful and satisfactory means of keeping the pilots flying informed of their speed conditions during all stages of the takeoff roll (and/or the abort maneuver).

The presence of the HUD did not and should not cause the pilots flying to rely any less on the pilots not flying.

Even though the pilots flying had most of the essential information available on their HUD's, they still preferred that the pilots not flying have primary responsibility for monitoring the TOPMS on their HDD's and apprise them of particular speeds and/or significant performance anomalies (such as a triangle separation).

Three TOPMS-HUD symbology elements warrant improvement. First, the abstract airplane symbol should be replaced with a more realistic one (similar to the one used in the head-down display). Second, a color other than light blue should be used for the EPR bars. Third, the acceleration-error indicator should be more compatible with the direction of the acceleration; it definitely should not move across the path of the graphic airplane.

The simple "box/line" airplane symbol used in the HUD was an artifact of TSRV/TOPMS simulation limitations (viz, a tradeoff between graphics sophistication and overall computational speed.) This symbol is currently being replaced with a more realistic graphic. However, for purposes of this study, the box/line symbol was deemed acceptable, and none of the pilots indicated that it affected their ratings of the HUD displays.

Light-blue EPR bars were used in the HUD to match other engine information (including the EPR bars on the HDD), which was displayed in blue. The EPR bars have since been changed to white in both displays.

The acceleration-error indicator (used only in the HUD) received a mixed reaction from the evaluation pilots. Many opted to ignore it because it was an unfamiliar cue that behaved in an unnatural manner; in particular, the pilots found it unnatural to associate leftward (negative) movement of the pointer with deficient acceleration in the longitudinal direction. On the other hand, several pilots quickly understood its message and said they appreciated having advance warning that an unacceptable performance-deficiency situation might be developing.

The pilots agreed that implementation of some type of acceleration-error symbology in the TOPMS displays would permit a more timely assessment of whether a longitudinal-acceleration anomaly was primarily drag or thrust related. Even though the pilots generally did not prefer the "error-wedge" display configuration that was evaluated (fig. 11), they indicated that the parameter itself provided vital information and warranted satisfactory implementation in both displays.

Several pilots commented that the TOPMS displays should not be updated after the airplane has reached V_1 . Several other pilots said that active TOPMS operation should be extended into the climbout phase by having appropriate attitude information switched into the HUD so that the pilot flying did not have to transition to another display (viz, the Primary Display) while establishing the climbout angle.

The TOPMS software was designed so it could be readily disabled at any point and/or pitch information could be easily added at or before liftoff. These features were discussed but not included in the scope of the study.

Comments on head-down displays. Paraphrased comments offered by the pilots not flying are presented in the italicized paragraphs. Discussion of these comments then follows. (Eight of the evaluation pilots had also seen and evaluated the initial head-down TOPMS display during the ref. 8 study.)

The head-down display and the HUD provide useful information even before the takeoff roll begins.

All the alphanumeric information shown in figure 5 is displayed for easy reference before and during the takeoff roll. After the actual runway length is

entered (fig. 7), both the HDD and the HUD show the pilot approximately how much margin is available between the rotation point (the apex of the triangles) and the GRLL. Improper flap settings are announced with a large "X" across the screen and a "Flaps" message. Grossly inappropriate initial values (e.g., erroneous inputs) for several other parameters are indicated with an "Invalid data" message on the NCDU screen.

The EPR bars should replace rather than be in addition to the engine flags in the head-down display.

Although the TOPMS EPR bars may not provide the precise resolution desired for making the final setting of the throttles, they do provide other useful cues such as a thrust imbalance between the two engines, the onset of an engine failure, and an indication of the failure (when the bar shrinks enough in length that it turns red). Thus, the red bar acts as an engine-failed flag and a blue (or preferably a white) bar denotes that the engine performance is acceptable.

The triangles, the GRLL, and the "X" provide the most fundamentally useful information on the HDD during the takeoff roll; then during aborted takeoffs, the "X" and the oval-shaped symbol provide important and highly usable stop-point information.

This finding, first reported in the reference 8 study, was reaffirmed by the pilots in the current study. Several pilots expressed concern about the accuracy of the maximum-braking calculations for nondry pavements. This widely recognized and long-held concern may lessen when more appropriate friction data bases, which are derived from empirical braking data, become available and can be stored in the flight computer. The critical task then becomes identifying the actual surface condition by the pilots and/or airport personnel. Once an abort is under way, the oval-shaped symbol provides a good indication of how near maximum braking for the condition is being achieved.

Items that could be omitted from the head-down display without significant loss of effectiveness include the blinking amber SAF, the duplicate speed box/line on the right side of the airplane, and the engine flags.

The amber flag occurs at a time when pilots' mindsets are to "GO," and they do not want to deal with another critical decision at this stage unless, for example, the failed engine is on fire and/or there is smoke in the cabin. Even so, the evaluation pilots generally did not want to retain this flag; they would rather deal with such situations on an ad hoc or emergency basis.

The duplicate CAS box and the attached line on the right side of the airplane symbol were added after the reference 8 study to provide a simple analog cue (viz, the moving CAS line closing on the nearly stationary V_R line) for initiating rotation. While this addition may have merit for an airplane that has a larger differential between V_1 and V_R , it was not very practical on the TSRV where the differential speed is generally less than 4 knots. (In the present study, several pilots not flying said they made their V_R call just after the left-side CAS line crossed the V_1 line, so in a sense, the V_1 line provided a practical reference for making the call.)

The EPR bars, with their color capability, provide adequate information concerning the condition of the engines, thus the engine flags are superfluous and have been removed.

When an abort is initiated, the takeoff display converts quickly and smoothly to the abort display (fig. 14); then the oval-shaped symbol (with the stop point based on measured acceleration) provides good insight on how hard to press the brakes to stop as quickly as possible or to stop at another desired location.

This same comment was made by pilots in the reference 8 study and was reaffirmed by the pilots in this study.

The TOPMS head-down display would be easier to monitor if it were located higher on the instrument panel, even when the pilot also has a HUD.

This reference was a speculative comment made by many of the pilots not flying (who did not have a HUD in front of them). However, when questioned further, these pilots and the pilots flying said they would not be willing to interchange it with the PD (composed of attitude, altitude, and control-command information) unless some of the PD information (in lieu of the navigation information) was temporarily switched into the TOPMS for the liftoff and initial climbout.

A mixed reaction was received to the question of having an "on/off" switch for a HUD. Almost all of the pilots flying wanted to have a full-time HUD; most of the pilots not flying were not sure whether they wanted a full-time HUD because they felt it might distract them from monitoring the HDD and other items in the cockpit. However, a number of the pilots said that they would like the capability to switch on a HUD. Therefore, the investigators concluded that the question probably should not have been raised because the simulator was not equipped to provide a HUD in front of both seats.

The pilots also said that they would like to see the abort display adapted to landing/rollout and/or aborted landings (called go-arounds).

Pilot Ratings of Displays

Sixteen of the pilots gave separate ratings for the TOPMS head-down and head-up displays. A seventeenth pilot (airline pilot) observed one full session and flew a partial set of runs; however, this pilot preferred not to give a numerical rating, but did provide useful comments.

To aid the pilots in arriving at their numerical ratings, they were asked to use the questionnaire shown in appendix B in conjunction with the abbreviated rating criteria shown in the blocks of figure 16. Their answers to the applicable questions are tabulated and discussed in part 2 of appendix B. In particular, the answers to several key questions by two of the pilots were inconsistent with their numerical ratings, so their ratings are reported in appendix B, but these ratings are not compiled along with the other ratings in figures 17 to 19.

A distribution of the ratings by the remaining 14 pilots is shown in figure 17. One-half of the pilots rated the HUD "very good" (PR of 2) and four rated it excellent (PR of 1). One pilot rated the HUD as a PR of 4.5 because he could not decide between a PR of 4 or a PR of 5. This pilot said that he tended to "lose track of V_1 " because it was not specifically shown on the HUD for reference similar to that on the HDD. (This pilot also liked to watch the CAS line closing on the V_1 line in the HDD.) The ratings for the HDD were more normally distributed (as shown by the white bars in fig. 17), with 11 of the ratings considered "good" (PR of 3) or "very good" (PR of 2). Two pilots rated the system with a PR of 4 because they thought some important changes should be made (e.g., that the system needed a deletion of the right-side CAS information and that the display should be located higher on the instrument panel).

In figure 18, the ratings of the 14 pilots are averaged overall and by experience and work groups, but because of their subjective nature, these ratings are not treated statistically otherwise. In general, the average HUD rating was approximately a PR of 2, or about a 0.5 point better than that of the HDD's. The largest average rating difference (PR point of 1) occurred among the U.S. Air Force pilots, even though only one rating below a PR of 3 was given (see appendix B). The average difference between the HDD and the HUD for the airline pilots was 0.3 point, and there was a zero average-rating difference for the three other pilots.

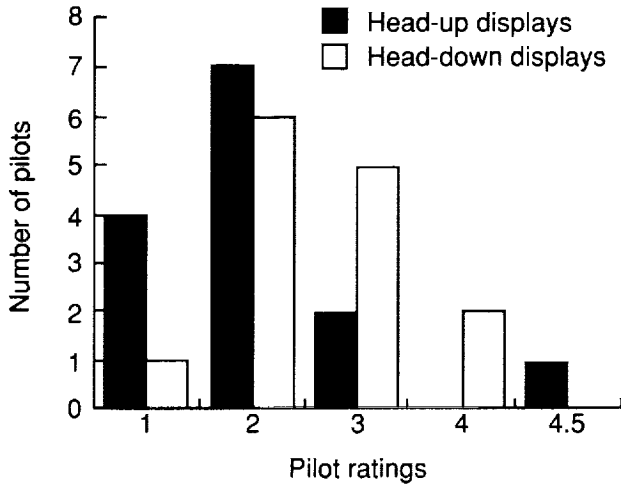

Figure 17. Pilot ratings of TOPMS displays.

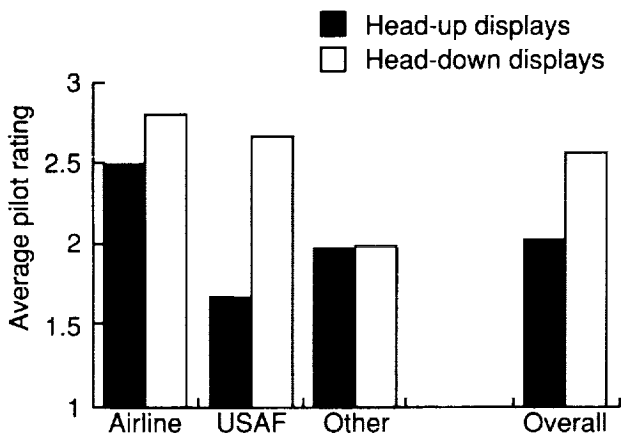

Figure 18. TOPMS ratings by pilot experience group.

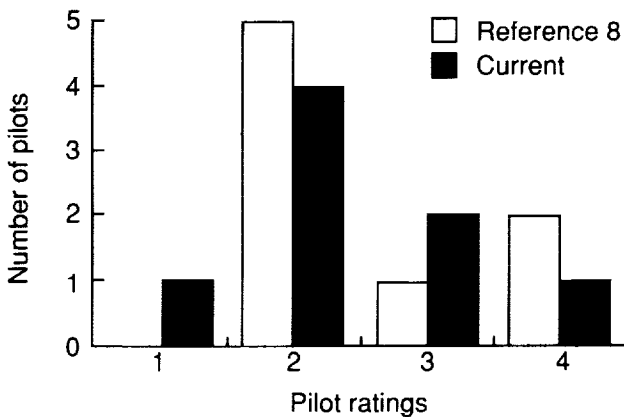

Figure 19. Comparison of pilot ratings of original and revised TOPMS head-down displays.

Eight of the pilots in this study also participated in evaluating the original HDD in the reference 8

study. As shown in figure 19, their average ratings for the revised HDD were slightly better (PR of 2.4) than those for the original configuration (PR of 2.6).

Based on the results of this study and its predecessor (ref. 8), it is confirmed that the TOPMS (algorithm and displays) provides transport pilots with valuable head-up/head-down safety, status, and takeoff/abort advisory information that is not otherwise available on today's airplanes. The TOPMS also provides this information in a clear, understandable, easy-to-monitor format, and the displayed information satisfactorily complements other information in the cockpit and the out-the-window visual scene.

Concluding Remarks

The Takeoff Performance Monitoring System (TOPMS) evaluated in this study provides an initial indication of how pilots might accept and use combined head-down displays (HDD's) and head-up displays (HUD's) to obtain pertinent system status and airplane performance information during take-off/abort maneuvers. The TOPMS displays were implemented on the Transport Systems Research Vehicle (TSRV) Simulator for the Boeing 737 airplane at the Langley Research Center and evaluated by 17 government and industry multiengine-rated pilots. The pilots rated the displays "good" to "very good" within an overall category entitled "satisfactory," and the pilots encouraged the continued development and evaluation of these displays. The evaluation pilots said that the TOPMS provides valuable, timely, and highly pertinent information that currently is not available in the cockpit.

This study concludes that the TOPMS is an appropriate information system for the pilots to use during airplane takeoff/abort maneuvers. The displays were judged to be easy to monitor, and the information presented was declared timely, credible, and compatible with other information on the instrument panels and in the visual scene of the runway and surrounding landscape. Other conclusions include the following:

1. The TOPMS HUD enhances the pilots' visual airport scene out the front window. This display positions valuable takeoff performance and safety information where the pilots can easily see it as they look down the runway, and it does not mask any critical information contained in the visual scene.
2. Even if the pilots controlling the takeoff have a TOPMS HUD available, they would still prefer that other pilots take primary responsibility for

monitoring the TOPMS, apprising them of anomalies, and making the customary speed calls.

3. Based on pilot opinion in this study, monitoring the TOPMS does not appreciably increase the mental work load of either pilot; in fact, with more familiarity, it may even help reduce this work load.
4. The along-track-acceleration error is an important performance parameter that should be displayed prominently and appropriately in both the HUD and the HDD. This error and the engine-pressure-ratio (EPR) bars, the triangles, and the ground-roll-limit line (GRL) form a very important cluster of basic information that can have a significant influence on the pilot's decision to continue or abort a takeoff. Additionally, the Situation Advisory Flags (SAF's) provide the results of the TOPMS algorithm analysis of the takeoff situation in the form of symbolic "GO" or "NO-GO" advice.
5. The SAF's are appropriately sized and colored in the HUD; however, in the HDD, the single size for all situations may not be appropriate if graphics color capability were to be lost or washed out by glare.
6. The TOPMS HDD and HUD displays were judged to be satisfactory; however, several practical

improvements and/or alternatives were suggested for consideration:

The engine flags in the HDD and the amber SAF in both displays should be deleted.

The horizontally oriented along-track-acceleration indicator in the HUD was found to provide valuable advance performance-deficiency information, but it may be more appropriate to provide symbology that moves in the longitudinal direction. Duplicate symbology for this parameter should also be incorporated into the HDD.

The primary recommendation from this study is that the suggested changes in the HDD and HUD displays be made and verified on the simulator. The revised HDD then should be implemented and tested on the TSRV Boeing 737 airplane at the Langley Research Center. No further testing of the HUD is expected unless an opportunity becomes available to test it on an airplane that is already equipped with an appropriate HUD.

NASA Langley Research Center
Hampton, VA 23681-0001
October 8, 1992

Appendix A

Pilot Information Package

1. PURPOSE OF THE TOPMS - To provide guideline information to the pilot(s) for making control decisions concerning takeoffs and aborts.
2. PILOTING OBJECTIVE/TASK - To control the TSRV airplane during takeoff, to decide IF/WHEN to abort, and to perform the abort if required.
3. SIMULATION OBJECTIVES
 - a. Primary - To qualitatively (and quantitatively) evaluate the TOPMS (viz. to solicit pilot comments/suggestions on existing features and modifications (if any) prior to implementing the hardware/software on the TSRV airplane; also to rate the TOPMS displays using the rating chart and criteria provided. [See Appendix B]).
 - b. Secondary - To obtain representative groundroll, liftoff, etc. data.
4. TOPMS ALGORITHM - Calculates a predicted performance based on:
 - a. Ambient temperature
 - b. Pressure altitude
 - c. Winds: speed and direction
 - d. Gross weight/c.g. location
 - e. Flap setting
 - f. Rolling/braking friction coefficient
 - g. Runway length/direction & "offset" (starting position)
 - h. Airplane's updated position, velocity, and acceleration
5. DATA INPUT/OUTPUT - The above information is entered into the flight computer through the Nav & Control Display Unit (NCDU) and/or by sensors. The TOPMS algorithm then makes a "pretakeoff" prediction of:
 - a. Distance down the runway where V_1 and V_R will occur
 - b. Balanced Field Length (BFL) - (defined on next page)
 - c. Groundroll limit to reach V_R
 - d. Normal or reduced-thrust throttle/EPR settings

In real-time, the algorithm updates (a) above and also continually predicts a brake-to-a-stop point based on maximum wheel braking and full ground-spoiler deployment. In the ABORT mode, it additionally computes a predicted stop point based on actual braking/deceleration conditions (including reverse thrust, if applied).

6. TOPMS DISPLAYS - The takeoff/abort advisory information generated and output by the TOPMS algorithm is presented to the pilots on CRT-type display screens located on the cockpit instrument panel (see sketch on the next page).

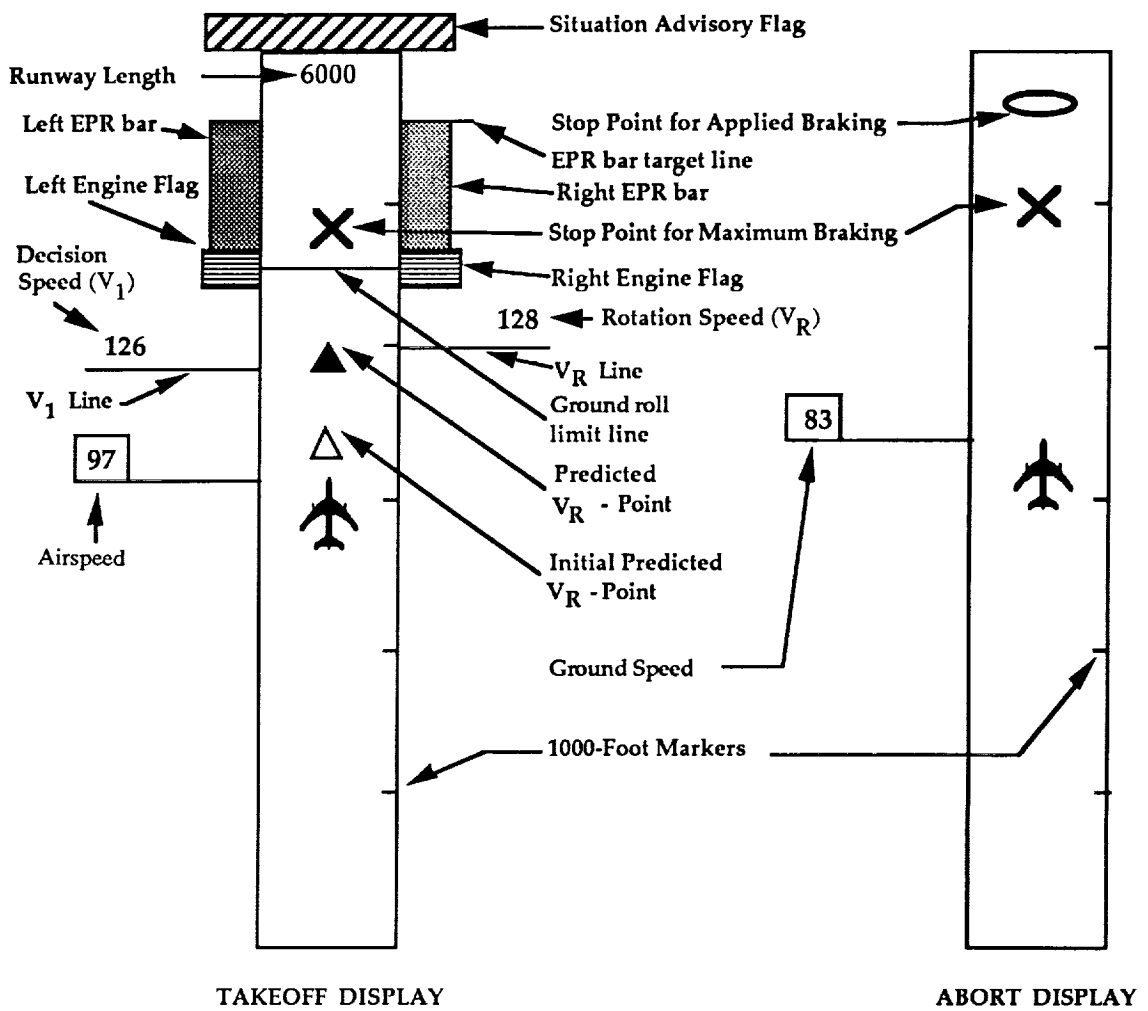

Elements of proposed TOPMS-HDD

TOPMS HEAD-DOWN DISPLAY (HDD): INTERPRETATION OF FUNCTIONS/SYMBOLOLOGY

RUNWAY LENGTH - Pilot enters value (in ft.) for the local airport; this value is then displayed digitally at far end of the runway graphic and sizes the graphic to the full height of the CRT display screen. Initially, - **BALANCED FIELD LENGTH (BFL)** appears as a default runway-length value; BFL is defined as the groundroll distance (required to reach V_1), plus the greater of:

- the braking (wheels + spoilers) distance to stop from V_1 , or
- the ground distance between V_1 & V_R combined with the air distance required to rotate & clear a height of 35 ft. at the end of the runway with one engine failed.

AIRPLANE SYMBOL - Tip of airplane's nose indicates present longitudinal position of the airplane on the runway graphic.

DIGITAL No. in BOX (extending from nose of airplane symbol) - Gives calibrated airspeed (CAS) in kts; box(es) & #'s advance with airplane.

SOLID TRIANGLE (▲) - Apex indicates longitudinal position on the runway where the airplane will reach a CAS of V_R .

- Digital number to right of (▲) indicates V_R in knots
- Digital number to left of (▲) indicates V_1 in knots

(Note: both the #'s & lines move with (▲) as it is updated.)

OPEN TRIANGLE (△) - Indicates initial position of solid triangle. Note that THIS TRIANGLE DOES NOT MOVE; it is for reference only!

ENGINE-OUT FLAGS - Will turn from GREEN to RED when the engine "fails" (e.g., when EPR < 85% of value "commanded" by throttle).

LINE BETWEEN E.O. FLAGS - Marks limit of the groundroll distance to V_R for clearing a 35-foot fence with one engine failed; this line repositioned automatically whenever a new value for RUNWAY LENGTH is entered through the NCDU.

EPR BARS - Roughly indicate status of engines (viz, if the throttles are set and the engines are operating at the proper level; also indicate engine failure by becoming shorter and turning red.)

SITUATION ADVISORY FLAG - Rectangle (RED/AMBER/or GREEN) at end of runway symbol.

✘ - Indicates where airplane can be braked to a stop from current conditions using maximum wheel braking (main gear) and fully deployed ground spoilers. [The **✘** does not appear until the predicted stop point is beyond the GRLL or when an ABORT FLAG appears. When the **✘** goes beyond the end of the runway, it blinks to alert the pilot that he should no longer consider an abort.]

○ - During an abort it indicates stop point based on current level of deceleration. It is affected by braking, drag, and reverse thrust (when applied), whereas computation of **✘** takes no credit for reverse thrust.

WHEN ABORT INITIATED, TAKEOFF DISPLAY CONVERTS TO ABORT DISPLAY. (See "Elements of proposed TOPMS-HDD" fig.)

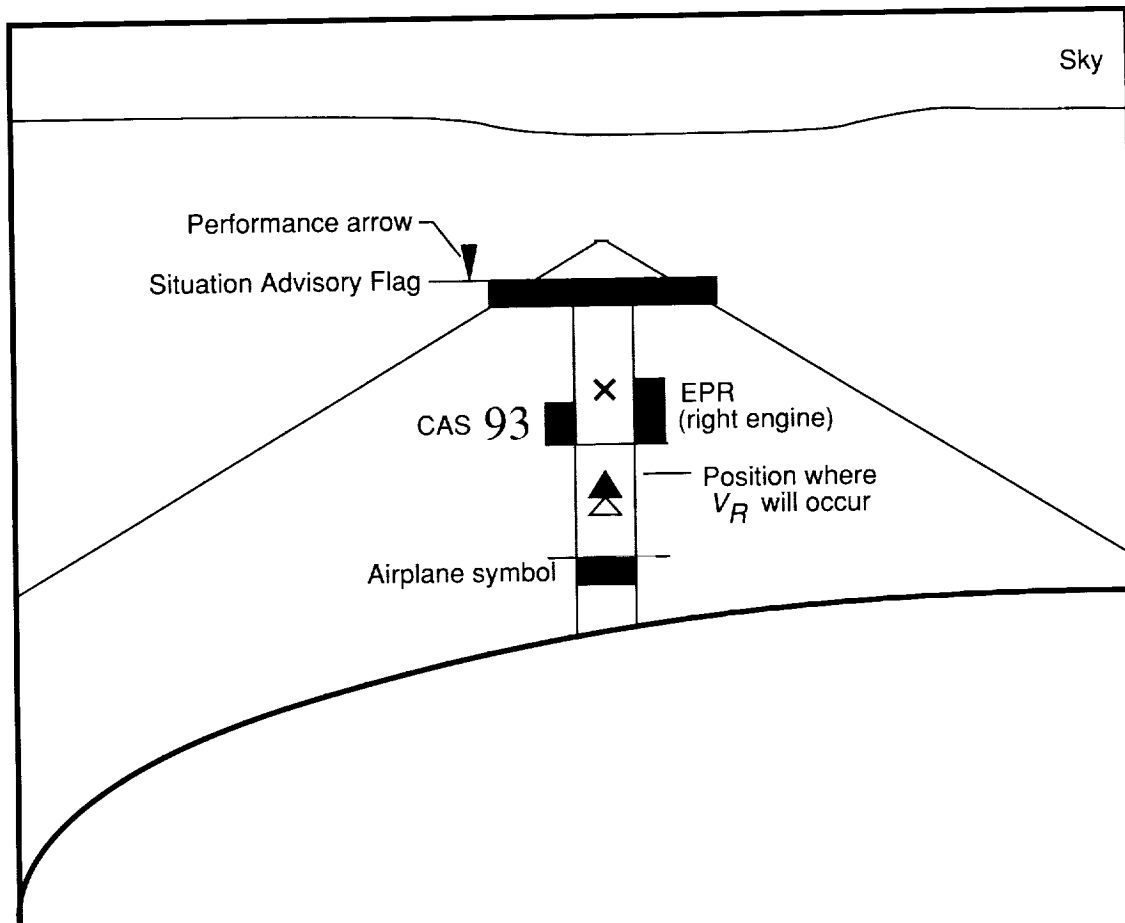

NOTES

- * HUD CAN BE REPOSITIONED WITH RESPECT TO THE RUNWAY PICTURE
- * PILOT CAN SEE MORE OF RUNWAY SYMBOL BY LEANING FORWARD AND LOOKING OVER INSTRUMENT PANEL

CASE SHOWN: LEFT ENGINE FAILED AT CAS < DECISION SPEED

- * EPR BAR DOWN ON LEFT SIDE, AND HAS TURNED RED
- * PERFORMANCE ARROW HAS SHIFTED LEFT SIGNIFICANTLY
- * SOLID TRIANGLE HAS MOVED FORWARD OF OPEN TRIANGLE

ABORT ADVISED

- * SITUATION ADVISORY FLAG IS ELONGATED AND RED
- * STOP POSSIBLE; **X** IS STILL ON RUNWAY

Sketch of Proposed HUD for the TOPMS

TOPMS HEAD-UP DISPLAY (HUD): INTERPRETATION OF FUNCTIONS/SYMBOLOLOGY

The TOPMS-HUD uses a simpler form of the TOPMS Head-Down Display (HDD) functions and symbology. It also includes an ACCELERATION PERFORMANCE INDICATOR (arrow on top of SITUATION ADVISORY FLAG) to let the "pilot-flying" know if/when a performance margin is about to be exceeded (see PERFORMANCE ARROW below).

The following differences between the two displays should be noted:

RUNWAY SYMBOL - Somewhat narrower on TOPMS-HUD.

SITUATION ADVISORY FLAG - Horizontal dimension ("width") varies according to color:

- Green - Same width as runway symbol
- Amber - Twice the width of the runway symbol
- Red - Three times the width of the runway symbol

PERFORMANCE ARROW

- Centered at end of runway symbol for "nom. accel. $\pm 5\%$ "
- Two runway widths right/left for "nom. accel. $\pm 10\%$ "
- Three+ runway widths right/left for accel. deviation of more than 15% from nominal (i.e. for the throttle setting). (This condition results in a RED Situation Advisory Flag).

EPR BARS

Similar to those on the Head-Down TOPMS display; however, since there are no E.O. Flags, these bars give (an) E.O. cue(s) when one (or both) bars turn red and deviate noticeably from reference mark (or from each other). For this study, the EPR bars were scaled (for any set of conditions selected) so the top ends align (for convenience) with the 1000-ft-to-go marker (on runway symbol) when the correct throttle setting has been made and there is no EPR

error/deficiency. The bottom of the EPR bars align (arbitrarily) with the GROUNDROLL LIMIT LINE.

AIRPLANE SYMBOL

More abstract than for TOPMS-HDD. It consists of a horizontal line (extending beyond both edges of the runway graphic) across the front edge of a solid box (representing the airplane fuselage) that moves down the runway during the takeoff roll (or abort). The line indicates current position.

AIRSPEED -

There is no attached "CAS box" like in the TOPMS-HDD; instead, large numerals which represent Calibrated Airspeed (CAS) in knots are displayed at a fixed location beside runway symbol.

NOTES:

1. No V_R or V_1 lines, Target-EPR and V_2 values, EO flags, or wind vector. (Pilot-not-flying will monitor these on TOPMS-HDD.)
2. TOPMS-HUD projection centered on runway in out-the-window scene; other locations may have objectionable interference from the background scene (trees, buildings, etc.) Comments on this location are solicited.
3. When ABORT initiated, Takeoff-HUD reduces to simple Abort-HUD.

FLAG CONDITIONS FOR SITUATION ADVISORY FLAG (SAF)

RED

1. Airplane will not reach "ROTATION SPEED" (V_R) within the groundroll distance allowed (i.e., without first reaching the GROUNDROLL-LIMIT LINE (GRLL), beyond which the airplane may not be able to rotate and clear a 35' obstacle at the end of the runway with one engine failed).
2. Performance failure detected (viz., measured along-track acceleration is not within $\pm 15\%$ of that expected for the throttle setting being used).¹
3. One engine fails when AIRSPEED (CAS) is less than V_1 ("DECISION SPEED").
4. Both engines fail.

AMBER - Blinking

5. One engine fails when airspeed is greater than V_1 ; however,
 - * airplane can reach V_R before reaching the GROUNDROLL LIMIT LINE, AND
 - * there is ample runway still available for braking-to-a-stop.²(Note - Braking involves wheels/spoilers only; no credit is taken for reverse thrust.)

GREEN

6. One engine fails when airspeed is greater than V_1 ; however, the airplane can reach V_R before reaching the GRLL, BUT there is NOT ample runway still available for braking-to-a-stop.²
7. Normal Takeoff — Everything appears to be proceeding O.K.!!!

- Notes:
- 1 The $\pm 15\%$ acceleration deviation (from “nominal”) was selected in this study as the threshold for an “acceleration performance failure”; another value can be used just as well.
 - 2 “Ample runway distance available for braking-to-a-stop” includes computed distance requirement for dry asphalt.

PILOT RATING INSTRUCTIONS

A numerical/adjective rating of the TAKEOFF PERFORMANCE MONITORING SYSTEM (TOPMS) will help establish the "goodness" of the TOPMS algorithm and the logic governing the advisory flags (or other annunciators). This goodness is manifested by the TOPMS display(s) which are comprised of alphanumeric, graphics, and colored flags. As the pilot evaluator, you should be concerned with judging the display contents/dynamics *per se*, with secondary consideration being given to size, location, or integration with other information sources. These secondary factors should, however, be identified and mentioned in your comments and/or answers to the associated rating questions (appendix B) and/or to the more general debriefing questions (appendix C) that you will be asked orally by the investigators.

Two ratings are sought: one for the revised Head-Down Display (HDD) and one for the simplified Head-Up Display (HUD). The same rating diagram/scale (see fig. 16) and associated questionnaire (appendix B) as were used in the initial study (refs. 7, 8) will be used here. Several additional questions concerning only the HUD are added to the HUD questionnaire; they are marked with an (*) in the left margin. The rating diagram is patterned after the Cooper-Harper Rating Scale for evaluating aircraft handling qualities and should be used in much the same manner. The evaluator should begin at the bottom left and proceed upward and/or to the right. The associated questions are designed to flow accordingly, and should assist in determining which criteria are met. It is requested that the flow-chart and questionnaire be explored together fully before a rating is made; then on the second time through, the chart/questionnaire will lead you to a numerical rating (1-10).

[The debriefing questions (appendix C) were not given to the evaluation pilots; however, the rating diagram (fig. 16) and associated questionnaire (appendix B) were included in the prebriefing package sent to them. This package also included a photograph of the TSRV B-737 Simulator Research Flight Deck (fig. 3).]

Appendix B

Pilot Evaluation Questionnaire and Answers

Part 1. Questionnaire for Rating TOPMS Displays

1. Are the TOPMS displays "USEABLE", and do they support the task?
If not, WHY NOT? (Y/N?)
2. If so, then are they "ACCEPTABLE" as configured/implemented? (Y/N?)
 - a. Is the information adequate and suitable for the task(s) being performed?
 - b. Are the displays believable; that is, do they clearly relate the dynamic situation to the pilots and complement their comprehension of the situation?
 - Are they free of contradiction within themselves?
 - Does information on the HUD display agree with similar type information obtained from the cockpit instruments and from the airport scene (upon which it is superimposed)?
 - c. Are the quality and dynamics of the displays tolerable (even though they may contain some annoyances/deficiencies)?
 - d. Does the monitoring task require no more than a moderate mental workload?
3. If the system, as implemented, is considered "UNACCEPTABLE", skip to Question 7; otherwise, continue.
4. Is the system "SATISFACTORY", requiring no significant modification? (If not, skip to Question 6) (Y/N?)
 - a. Is the displayed information adequate, and well suited for the task?
 - * Does the HUD complement the visual "real-world" airport scene?
 - b. Do the displays have good clarity? resolution? contrast? and dynamics?

- *
 - c. Does the HUD relate to the “real world” scene with a minimum of annoyances such as lag, stepping, smearing, flicker, etc.?
 - d. Does the monitoring task require low mental effort?
- 5. Go to Question 8, and continue.
- 6. From Question 4 ... What IMPROVEMENTS ARE WARRANTED? That is, what can and should be changed to make the system SATISFACTORY? In particular,
 - a. What elements or combinations of elements contain:
 - Minor deficiencies? What are they?
 - Moderate deficiencies? What are they?
 - Major deficiencies? What are they?
 - b. Which deficiencies, if any, are considered to be somewhat annoying but do not lead to confusion, decreased comprehension or noticeably degraded performance?
 - c. Which deficiencies warrant correction in order to:
 - Eliminate significant annoyances (and reduce mental workload)?
 - Increase the ease of comprehension and/or the ease of monitoring the display?
 - d. Skip to Question 8, and continue.
- 7. From Question 3 ... What makes the system “UNACCEPTABLE”?
 - a. Poor input information (or lack of good info) from algorithm?
 - Desirable information missing or presented inappropriately?
 - Excessive, irrelevant, and/or (unnecessary) redundant information?
 - Correct but not particularly helpful information?
 - b. Display format?
 - Poor choice and/or placement of symbols and airspeed?
 - Unrealistic size/movement of symbols/flags?
 - Inappropriate appearance/disappearance of certain cues?
 - * - Not enough digital information on the HUD? Is digital CAS easy or hard to monitor while looking down the runway?

- * - Other? (e.g., is it incompatible with the airport scene?)
- c. Display credibility?
- What factors affect the credibility? Is more than one parameter or feature involved?
 - Would a different choice of graphics enhance the credibility? Or does any credibility problem lie with the input info?
 - In what respect does the displayed information conflict with concurrent information obtained from other sources? (such as motion or visual cues (from out-the-window scene))?
- * - Other factors?
- d. Mental workload / intensity of concentration
- High?
 - Tolerable?
- e. Other:
- Display quality (resolution, contrast, scaling, etc.)?
 - Interpretation, readability, and followability of display?
 - Location of display? Would it be or become ACCEPTABLE in another location?
8. From Question 5, page 1 of this handout What changes would you recommend in the following?
- a. Input information?
 - b. Display format and/or symbolism? Size? Contrast?
 - c. Display dynamics?
 - * d. Location in cockpit? Where should the HUD be centered?
9. Are these recommendations, if any, suggestions for improvement of the existing system, or are they investigative alternatives?
10. END....

Note: * Indicates additional questions, concerning only the HUD.

Part 2. Answers to Applicable Questions in Part 1

In accordance with their instructions on the use of the rating diagram (fig. 16) and associated questionnaire, the pilots answered key questions, as shown in table B1. The purposes of the questionnaire were (1) to provide the pilots with more detailed rating criteria than could be put into the various blocks of the rating diagram and (2) to methodically guide the pilots through the rating process before they select their numerical rating. The data in table B1, however, may be partially unsolicited because the investigators did not require the pilots to submit their answers. Table B1 was compiled as an afterthought from the answers circled or written on the 12 questionnaires that were turned in with the rating sheets. (Because of a long delay between the time when the simulation was conducted and when the answer sheets were analyzed, the pilots were not contacted for clarification of their answers and ratings.)

All 12 pilots (who answered the questions on paper) answered “yes” to question 1 for both the HDD and the HUD, thus indicating that they all considered the TOPMS a “usable” system. All 12 pilots also answered “yes” to question 2 for the HUD, and 11 answered “yes” for the HDD. Six of them answered “yes” to all subparts of this question for the HDD, and seven answered “yes” for the HUD. Five pilots did not mark any of the subparts. Based on their answers this far, 11 of the 12 evaluators considered the TOPMS “acceptable” and were thus directed to the “satisfactory” test block (upper left) of figure 16 for the HDD; all 12 pilots were directed there for the HUD.

The lone dissenter, pilot 15, answered “no” to question 2 for the HDD, thus indicating that he thought the system was “unacceptable,” and this pilot was thus directed to the rating block indicating a PR of 7, 8, and 9 on the right side of the ratings diagram. However, the pilot rated the HDD an unusual 4.5, which indicated that he had taken the path to the block with a PR of 4, 5, and 6 just above it. (The pilots were instructed not to use 0.5 point ratings.) The discrepancy was then compounded when he answered “yes” to question 4, thus indicating that he thought the system was “satisfactory.” This response should have directed the pilot to select the block that indicated a PR of 1, 2, and 3. Consequently, this pilot’s rating was not included in the primary averages (for pilots 1 to 14). A second discrepancy arose when pilot 16 answered “yes” to question 4 and then proceeded to give the HUD a PR of 4; this pilot’s ratings were also not included in the primary averages. (Only the primary data are used in figures 17 to 19.)

Question 3 was actually a branching instruction that sent all HUD evaluators and all HDD evaluators except pilot 15 to question 4. All except pilot 10 answered “yes” to question 4 for the HDD; this pilot answered “no” and branched to the corresponding ratings block and rated the system “fair—PR of 4.”

Of all those who answered the subparts to question 4, only pilot 1 answered negatively; this pilot disliked the “fuzziness” of the HUD graphics, yet he rated the HUD overall “very good—PR of 2,” which did not appear to be inconsistent or contradictory. This pilot liked the HUD conceptionally and functionally and did not let a noticeable simulator implementation deficiency affect his overall judgment.

Questions 5 to 7 were out of the rating path for all evaluators and their answers to questions 8 to 9 are integrated into the section entitled “Pilot Opinions and Comments.”

Table B1. Pilot Answers to Questionnaire and Ratings

Pilots		HDD question number							HUD question number								
Number	Group	1	2	4	4a	4b	4c	PR	1	2	4	4a	4b	4c	PR		
1	USAF ^a	Y	Y ^b	Y	Y	Y	Y	3	Y	Y ^b	Y	Y	N	Y	2		
2	USAF	Y	Y ^c	Y	-	-	-	1	Y	Y ^c	Y	-	-	-	1		
3	USAF	Y	Y ^c	Y	-	-	-	2	Y	Y ^c	Y	Y	Y	Y	1		
4	USAF	Y	Y ^c	Y	-	-	-	3	Y	Y ^c	Y	Y	-	Y	2		
5	ALPA ^d	Y	Y ^b	Y	Y	Y	Y	2	Y	Y ^b	Y	Y	Y	Y	2		
6	UAL ^e	Y	Y ^b	Y	Y	Y	Y	3	Y	Y ^b	Y	Y	Y	Y	2		
7	VA-NG ^f	Y	Y ^b	Y	Y	Y	Y	2	Y	Y ^b	Y	Y	Y	Y	1		
8	USAIR	Y	Y ^b	Y	Y	Y	Y	2	Y	Y ^b	Y	Y	Y	Y	2		
9	USAF	Y	Y ^b	Y	Y	Y	Y	3	Y	Y ^b	Y	Y	Y	Y	2		
10	USAF	Y	Y ^c	N	-	-	-	4	Y	Y ^c	Y	-	-	-	2		
11	UAL	Questionnaires							3	Questionnaires							4.5
12	UAL	not marked							4	not marked							3
13	UAL	by these							2	by these							1
14	NASA	pilots							2	pilots							3
		Subtotals							36	Subtotals							28.5
		Primary average = 36/14							2.6	Primary average = 28.5/14							2.0
15	UAL	Y	N ^g	Y	Y	Y	Y	^g 4.5	Y	Y ^b	Y	Y	Y	Y	2		
16	ALPA	Y	Y ^c	Y ^g	Y	Y	Y	^g 4	Y	Y ^c	Y ^g	Y	Y	Y	^g 4		
		Rating points (total overall)							44.5	Rating points (total overall)							34.5
		Average = 44.5/16							2.8	Average = 34.5/16							2.2

^aUSAF is U.S. Air Force (EC-135 tanker pilots).

^bIndicates "yes" answer to question 2 and all of its subparts.

^cIndicates "yes" answer to question 2, but no subparts answered.

^dALPA is Airline Pilots Association.

^eUAL is United Airlines.

^fVA-NG is Virginia National Guard.

^gIndicates questionable rating and/or inconsistent answer to related question; these data not included in text figures.

Appendix C

Pilot Debriefing Questions: TOPMS Follow-On Simulation

The following questions were used as a minimum guide set to solicit comments concerning the TOPMS. The investigators orally asked the questions, and the evaluation pilots' answers and comments were recorded on cassette tape. Each pilot was debriefed individually and alone. Also, the pilots were not shown this list of questions in advance (whereas they were provided the questionnaire (appendix B) as part of the prebriefing package). Question 4 allowed the pilots to offer many unsolicited comments and to elaborate on why they rated the system (appendix B) the way they did.

1. How would a combined head-up/head-down TOPMS fit into your scan pattern and/or your guidance & control philosophy? In particular:
 - a. As the PILOT-FLYING –
 - * Does the head-up display (viz., the HUD) provide useful, adequate, and appropriate information for a takeoff/abort?
 - * Does it enhance/degrade the information that is provided by the out-the-window TV projection of the airport scene? (i.e., is it more distracting than helpful?...Or vice-versa?)
 - * How often did/must you glance inside the cockpit to other instrumentation (including the head-down TOPMS) –
 - When the TOPMS HUD is available?
 - When no HUD is available?
 - * Would having a TOPMS HUD available cause you to rely less on the pilot-not-flying for assessing progress, acceleration anomalies and engine health? Would you still want him to maintain primary responsibility for monitoring the TOPMS?
 - * Would you like to have your HUD on a “handy” ON-OFF switch?

b. As the PILOT-NOT-FLYING –

- * Does the head-down TOPMS display provide adequate advisory information to permit clear determination of current airplane status and performance?
- * Would it bother you if the pilot-flying had a HUD containing information that you couldn't see? (viz, acceleration error) Would your TOPMS monitoring task be lessened in such a situation? or would you still have to scan your display just as often?
- * What are your thoughts on the following display combinations (in addition to all the regular cockpit instrumentation):
 - a) HUD and head-down TOPMS displays for both pilots?
 - b) HUD for pilot-flying and head-down display for pilot-not-flying?
 - c) Head-down TOPMS displays (only) for both pilots?
 - d) TOPMS HUD's (only) for both pilots?

2. What are your comments /preferences concerning the TOPMS symbology?

a. Head-Down Display

- * Triangles
 - a) What useful information did you get from separation of the two triangles? from the position of solid triangle with respect to the GROUNDROLL-LIMIT LINE?
 - b) Which is the more vital reference - the stationary open triangle or the GROUNDROLL-LIMIT LINE?
 - c) Are the triangle dynamics satisfactory; e.g., does the solid triangle move too fast/slowly when the throttles are moved?
- * Airspeed
 - a) Where did you monitor airspeed? on TOPMS or the airplane's regular round-dial airspeed indicator?
 - as the pilot-flying?
 - as the pilot-not-flying?
 - b) Do you prefer a single CAS box on the TOPMS? or one on each side of the runway graphic (as presented in this study)?
 - c) Were the CAS numbers easy/difficult to read on TOPMS?

Did you read the digital number or did you rely on the CAS-line closure on the V_1 -line for your " V_1 " speed call?
d) Compare monitoring airspeed on TOPMS to monitoring it on the airplane's round-dial indicator.

- * Is the airplane symbol satisfactory? size? Is it satisfactory to have the nose of the airplane indicate current position? Should the airplane symbol have been allowed to move laterally?
- * It is appropriate to keep the stop-point "X" masked until this symbol crosses the GROUNDROLL LIMIT LINE or until an abort has been initiated? Should the "X" (blink/not blink) when it passes beyond the end of the runway pavement?
- * Is it helpful/unnecessary to display the RFL metric at the end of the pre-takeoff calculations?
- * Are the logic/colors/size of the engine flags and SITUATION ADVISORY FLAGS satisfactory and appropriate? Are both the engine flags and the EPR bars necessary?
- * Is there an inadequate/adequate/excessive amount of alphanumeric information displayed?
- * Was the wind vector useful or just interesting?
- * Are the EPR bars on the head-down display helpful/distracting after the takeoff roll begins? Do you use them to the exclusion of the regular engine instruments once the throttles are set?
- * Should there be any message windows in or near the head-down TOPMS Displays?

b. Head-Up Display (HUD)

- * Is the amount of information on the HUD inadequate, satisfactory, or excessive?
- * Is the size of the HUD satisfactory? i.e., large and bold enough to be useful/easy-to-monitor without masking out any important portions of the runway scene (e.g., centerline)?

- * Is it located in a poor/good position in the pilot's-field-of view as the they look down the runway? Is it too prominent with respect to other cues?
- * Was the HUD compatible with the background/peripheral airport scene throughout the run?
 - Could it be "read" without difficulty as the airplane neared takeoff?
 - Was it obtrusive/unobtrusive during a normal takeoff run?
 - Did you focus on the runway scene and monitor the HUD as a secondary awareness? or vice-versa?
- * Particular symbols:
 - Was the ACCELERATION PERFORMANCE ARROW helpful/distracting or easily ignored? - Should this arrow disappear when the "X" reaches the end of the runway and begins to blink? Is this feature something that should be retained and improved, or should it be deleted?
 - Are the EPR bars helpful in approximately setting the throttles while looking down the runway? In addition, are they an appropriate alternative to engine flags?
 - Are the SAF variable lengths and colors appropriate?
 - Were the airspeed numerals easily monitored or did you generally ignore them and rely on the other pilot to monitor airspeed and make appropriate speed callouts? Did you look back inside at the conventional round-dial airspeed indicator or at the CAS-line closure on the V_1 -line on the head-down TOPMS display?
 - Was the simplified airplane symbol in the HUD satisfactory?
 - Is the open triangle (as a reference) useful/necessary?
 - Would the "football" plus visual scene be an adequate HUD abort display - or should the "X" and the groundspeed be retained?
 - What other information would you like to see on the HUD?

3. In summary, what would you retain/change about the TOPMS HUD?

4. Other comments ... ?

References

1. Minutes of Meeting #1 of the Takeoff Performance Monitoring Ad Hoc Committee. Aircraft Div., Aerospace Council, Soc. of Automotive Engineers, Inc. (Washington, D.C.), May 15 & 16, 1984.
2. Bacqué, Peter: NASA Offers Airline Pilots Aid. *Richmond Times-Dispatch*, Sunday, Nov. 12, 1989, pp. C-8.
3. Small, John T., Jr.: "Feasibility of Using Longitudinal Acceleration (N_x) for Monitoring Takeoff and Stopping Performance From the Cockpit. *The 1983 Report to the Aerospace Profession—27th Symposium Proceedings*, vol. 18, no. 4, Soc. of Experimental Test Pilots, c.1983, pp. 143-154.
4. Cleary, Patrick J.; Kelman, Lloyd S.; and Horn, L.: Aircraft Performance Margin Indicator. U.S. Patent No. 4,638,437, Jan. 20, 1987.
5. Srivatsan, R.; Downing, David R.; and Bryant, Wayne H.: *Development of a Takeoff Performance Monitoring System*. NASA TM-89001, 1986.
6. Srivatsan, Raghavachari; and Downing, David R.: *Development of a Takeoff Performance Monitoring System*. NASA CR-178255, 1987.
7. Middleton, David B.; and Srivatsan, Raghavachari: Evaluation of a Takeoff Performance Monitoring System. *A Collection of Technical Papers, Volume 1—AIAA Guidance, Navigation and Control Conference*, Aug. 1987, pp. 155-162. (Available as AIAA-87-2256.)
8. Middleton, David B.; Srivatsan, Raghavachari; and Persson, Lee H., Jr.: *Simulator Evaluation of a Display for a Takeoff Performance Monitoring System*. NASA TP-2908, 1989.
9. Staff of NASA Langley Research Center and Boeing Commercial Airplane Co.: *Terminal Configured Vehicle Program—Test Facilities Guide*. NASA SP-435, 1980.
10. Cooper, George E.; and Harper, Robert P., Jr.: *The Use of Pilot Rating in the Evaluation of Aircraft Handling Qualities*. NASA TN D-5153, 1969.





REPORT DOCUMENTATION PAGE			Form Approved OMB No. 0704-0188	
Public reporting burden for this collection of information is estimated to average 1 hour per response, including the time for reviewing instructions, searching existing data sources, gathering and maintaining the data needed, and completing and reviewing the collection of information. Send comments regarding this burden estimate or any other aspect of this collection of information, including suggestions for reducing this burden, to Washington Headquarters Services, Directorate for Information Operations and Reports, 1215 Jefferson Davis Highway, Suite 1204, Arlington, VA 22202-4302, and to the Office of Management and Budget, Paperwork Reduction Project (0704-0188), Washington, DC 20503.				
1. AGENCY USE ONLY(Leave blank)	2. REPORT DATE December 1992	3. REPORT TYPE AND DATES COVERED Technical Paper		
4. TITLE AND SUBTITLE Simulator Evaluation of Displays for a Revised Takeoff Performance Monitoring System			5. FUNDING NUMBERS WU 505-66-01-02	
6. AUTHOR(S) David B. Middleton, Raghavachari Srivatsan, and Lee H. Person, Jr.				
7. PERFORMING ORGANIZATION NAME(S) AND ADDRESS(ES) NASA Langley Research Center Hampton, VA 23681-0001			8. PERFORMING ORGANIZATION REPORT NUMBER L-16761	
9. SPONSORING/MONITORING AGENCY NAME(S) AND ADDRESS(ES) National Aeronautics and Space Administration Washington, DC 20546-0001			10. SPONSORING/MONITORING AGENCY REPORT NUMBER NASA TP-3270	
11. SUPPLEMENTARY NOTES Middleton and Person: Langley Research Center, Hampton, VA; Srivatsan: ViGYAN, Inc., Hampton, VA.				
12a. DISTRIBUTION/AVAILABILITY STATEMENT Unclassified-Unlimited Subject Category 08			12b. DISTRIBUTION CODE	
13. ABSTRACT (Maximum 200 words) Cockpit displays for a Takeoff Performance Monitoring System (TOPMS) to provide pilots with graphic and alphanumeric information pertinent to their decision to continue or abort a takeoff are evaluated. Revised head-down and newly developed head-up displays were implemented on electronic screens in the real-time Transport Systems Research Vehicle (TSRV) Simulator for the Boeing 737 airplane at the Langley Research Center and evaluated by 17 NASA, U.S. Air Force, airline, and industry pilots. Both types of displays were in color, but they were not dependent upon it. The TOPMS head-down display is composed of a runway graphic overlaid with symbolic status and advisory information related to both the expected takeoff point and the predicted stop point (in the event an abort becomes necessary). In addition, an overall Situation Advisory Flag indicates a preferred course of action based on analysis of the various elements of airplane performance and system status. A simpler head-up display conveys most of this same information and relates it to the visual scene. The evaluation pilots found the displays to be credible, easy to monitor, and appropriate for the task. In particular, the pilots said the head-up display was monitored with very little effort and did not obstruct or distract them from monitoring the simulated out-the-window runway scene. This report augments NASA TP-2908, 1989.				
14. SUBJECT TERMS Takeoff; Takeoff performance; Aborted takeoffs; Rejected takeoffs; Cockpit displays; Electronic displays; Head-up displays (HUD's); Simulation; Simulator evaluation; Pilot evaluation; Performance monitor; Takeoff performance monitor; "GO/NO-GO"			15. NUMBER OF PAGES 43	
			16. PRICE CODE A03	
17. SECURITY CLASSIFICATION OF REPORT Unclassified	18. SECURITY CLASSIFICATION OF THIS PAGE Unclassified	19. SECURITY CLASSIFICATION OF ABSTRACT	20. LIMITATION OF ABSTRACT	