

N 9 3 - 1 5 5 9 8

Multi-axis Transient Vibration Testing of Space Objects — Test Philosophy, Test Facility and Control Strategy

Dr. Georg Lachenmayr
Industrieanlagen-Betriebsgesellschaft mbH — Abt. TFM
Einsteinstraße 20
W-8012 Ottobrunn

Abstract

IABG is using various servohydraulic test facilities since many years for the reproduction of service loads and environmental loads on all kinds of test objects. Since more than 15 years a multi-axis vibration test facility is under service, originally designed for earthquake simulation but in the meanwhile upgraded to the demands of space testing. First tests with the DFS/STM showed good reproduction accuracy and demonstrated the feasibility of transient vibration testing of space objects on a multi-axis hydraulic shaker. A novel approach to structural qualification is possible by using this test philosophy. It will be outlined and its obvious advantages over the state-of-the-art single-axis test will be demonstrated by example results. The new test technique has some special requirements to the test facility exceeding those of earthquake testing. Most important is the high reproduction accuracy demanding for a sophisticated control system. The state-of-the-art approach of analog closed-loop control circuits for each actuator combined with a static decoupling network and an off-line iterative waveform control is not able to meet all the demands. Therefore the future over-all control system is implemented as hierarchical full digital closed-loop system on a highly parallel transputer network. The innermost layer is the digital actuator controller, the second one is the MDOF-control of the table movement. The outermost layer would be the off-line iterative waveform control, which is dedicated only to deal with the interaction of test table and test object or non-linear effects. The outline of the system will be presented.

1 Introduction

Since the very beginning of structural testing the test engineers had the problem how to reproduce the real vibration environment, which very often is multi-axial. Due to the limitations of the available test hardware in most cases only a simplification to a single-axis test was possible. In the early 70's test laboratories in the whole world have started to develop methods and test facilities for the reproduction of multi-axial vibrations in structures. The first step was the simulation of random loads due to road roughness in automobil structures, see e.g. (ref. 1), afterwards it was achieved to simulate seismic loads due to earthquakes. The complexity of those test facilities reflects the technical problems associated with such tests. The now available multi-axis vibration test facilities can be divided into three groups:

1. **Multi-axis vibration tables:** Their purpose is the reproduction of seismic loads and similar transient events in 2-6 DOF¹ to all kinds of industrial components, as e.g. high-voltage switch gears, transformers or large control valves, see (ref. 2, 3, 4).
2. **Dynamic multi-actuator simulators:** They allow the reproduction of service loads in vehicle structures due to road roughness and maneuvers; the forces are usually introduced directly to the wheel suspension, see (ref. 5, 6, 7, 8, 9, 10). These test facilities have become an essential tool for the development and qualification of automobile structures.
3. **Dynamic roller test facilities:** On these facilities complete road or rail vehicles can be tested running on their wheels on the rollers which are moved due to the roughness profiles of road or rail, see (ref. 11, 12, 13).

¹ (mechanical) degree of freedom.

From these three types of multi-axis vibration test facilities a lot of installations exists all over the world. This paper *exclusively deals with the first group, the multi-axis vibration tables*, driven by electro-hydraulic servo actuators². Their first application certainly was earthquake testing; the most demanding one will be the testing of complete satellites in near future.

The availability of appropriate test facilities is one aspect of the multi-axis transient testing — it will be discussed more in detail in section 3. At least of the same importance is the derivation of the test signals and the test philosophy standing behind; this will be the topic of section 2. Some example results from tests will be shown in section 4.

2 Multi-axis Transient Test Philosophy

The external loading to which structures are exposed in their environment is *nearly always multi-axial*. Nevertheless most of structural testing is done in single-axis tests up to now due to the less testing effort. In this section the problems of this approach will be reviewed and discussed what benefits are available with the multi-axis transient test. Afterwards the steps necessary to prepare a multi-axis transient test will be discussed, especially the process needed for the derivation of test transients.

2.1 Problems of Single-axis Testing

The single-axis vibration test on the electrodynamic shaker is state-of-the-art for the mechanical qualification of components and structures of all kind. The signals used are *constant or swept sine, random* (shaped to a given PSD³) *shock* (synthetic) or *time histories* in a frequency range from about 5 – 10 Hz up to the kHz-range. Single axis tests are also often performed with hydraulic shakers, especially for larger test items — the frequency range is from ≈ 0 up to about 50 Hz⁴.

Most of the test specifications and applicable standards can be covered by that performance data; indeed the standards seem to reflect more the limits of the test facilities than the requirements of the environment to be reproduced. With respect to the reliability of the qualification test and the relevance of the whole procedure of single-axis testing one has to be aware of the following problems:

- single-axis excitation is a *strong simplification* of the real environment, as all except one components of the external loading vectors are neglected,
- the *superposition* of local responses due to several single-axis tests in different directions may be *not valid* due to the neglected phase relations; this is especially true in the case of non-linear structural dynamics,
- the neglect of *small DOFs* of the excitation (e.g. the rotational DOFs) can change the *local responses* drastically, especially in complex structures,
- on the other hand electrodynamic shakers normally produce reasonable *crosstalk*, which is *not controllable* due to their construction; on a multi-axis test facility these components are under control,
- *quasistatic components* (0 – 5 Hz) cannot be reproduced on an electrodynamic shaker due to its stroke limitation; especially for non-linear dynamics and in large structures the quasi-static loads are essential for realistic test results, as they determine e.g. pre-stressing and working points,
- the replacement of real (transient) loading by sine, random or shock is at least *dubious*, as this excites the structural modes in quite a different way as the real environment,
- therefore usually complicated *notching procedures* are necessary in order to avoid overtesting of critical parts; this automatically implies undertesting of the rest of the structure.

This list of problems underlines that the single-axis vibration test needs careful adaptation to the special circumstances, which normally is a drastic simplification. This procedure may certainly be justified and appropriate in the case of

²Due to the limited stroke and other design problem it is difficult to build up multi-axis test facilities with electro-dynamic actuators, see e.g. (ref. 14, 15, 16).

³Power spectral density.

⁴With small hydraulic actuators or special equipment frequencies in the range of 100-300 Hz are possible.

small components which must work under quite different conditions (e.g. small electric parts); then also the test philosophy of *enveloping spectra* might be a good choice. But in order to cover the uncertainty of the simplification process usually a reasonable 'safety factor' must be chosen; this implies over-dimensioned design.

2.2 Advantages of Multi-axis Testing

The multi-axis vibration and transient testing technique has been developed due to the demand of the reproduction of service loads as exact as possible for a more reliable qualification. The reasons for it are :

- the excitation at the *interface*, the interface accelerations, between the test object (component, device, satellite) and its surrounding structure (vehicle, building, launcher) can be reproduced *completely* and in all DOFs *simultaneously* during test,
- the test signals are equivalent to *real loading functions* in amplitude, phase, and frequency contents,
- therefore all relevant structural modes are excited similar to reality and *all* parts of structure are loaded correctly,
- *quasistatic components* (0 - 5 Hz) can be simulated due to the much larger stroke of electro-hydraulic servo actuators,
- *no* manipulations during test like 'Notching' are necessary; more precisely: they are not allowed as the test signals represent the real loading, the test object has to withstand,
- the results of identification tests with multi-axis excitation yield *effective, dynamic characteristics* on the level of the real loading; this is a valuable feedback for the verification or updating of the computer models.

The above listed advantages of the multi-axis testing gain more importance, if the structures under consideration become large and more complex. This is especially the case with lightweight constructions; they are very sensitive to overtesting. The accurate reproduction of the real stresses on the other hand causes a reasonable effort both for the test facility and for the definition of the test signal.

2.3 Derivation of Test Transients

The important prerequisite for multi-axis testing is a thorough knowledge of the service loads the test item has to endure. Normally only a measurement campaign under real service conditions is able to acquire this knowledge. On this basis there exist three possibilities to derive the input for a multi-axis test:

1. Direct measurement and reproduction of the interface accelerations,
2. Specification of synthetic signals based on engineering knowledge, specifications, standards or similar measurements,
3. Computation of the interface accelerations from the external loading functions by 'coupled analysis'.

The first approach — direct reproduction of measured signals — certainly is the easiest way to define the test input; it is e.g. state-of-the-art for testing against seismic loads. The only thing what is to be done is some pre-processing (filtering, resampling) in order to adapt the signal to the test facility.

The second way to define the test input uses specifications for the different DOFs from which synthetic transient or random-like time histories are generated; also 2-DOF-swept sine or sine-beat is used. This approach is applied often in earthquake and transportation testing.

The third approach seems to be more complicated, as it requires the measurement of the *external*. This can be not so easy in reality. But it has the great advantage, that the characteristics of the individual combination of test object and structure during the service measurement are eliminated. Therefore the external loads obtained are applicable also to new constructions. They can be used in the design process and very early for the test of engineering models. The interface accelerations are calculated with a coupled model of the test object in its surrounding structure under the external excitation, see Figure 1. The individual characteristics of a new test object are reflected in its mathematical submodel.

Summarizing the requirements for this procedure are:

1. representative measurements of external loads under service,
2. computer model of the test object,
3. computer model of the surrounding structure, and
4. new test philosophy.

The first three items are realisable quite straightforward in aerospace applications and in the automotive industry; a lot of measurement work is done there as well as computations with sophisticated models. The most demanding step perhaps is the definition of a *New Test Philosophy*.

As the transient multi-axis vibration test reproduces the real service loads quite well the test philosophy must be changed in comparison to the single-axis test:

1. selection of relevant loadcases (transients, external events) out of the service measurements which are the design drivers,
2. no enveloping spectra and similar coarse specifications as each transient has its individual properties,
3. definition of a new 'Safety Factor', which can be smaller as it has to cover only the scattering of material properties a.s.o. and not the problems of the test procedure,
4. finally randomization of relevant properties of the transients can be used in order to include the influence of parameter errors in the mathematical models or even the scattering of the external loading events.

The process for the last step is shown in Figure 2 and called 'mutation'. The original transient (which is the output of a coupled analysis, see Figure 1) is analysed with respect to its relevant components and is represented by some parametric approximation. Those parts which could change in amplitude, phase and frequency due e.g. model errors are marked to the mutation process; others which are well-known shall not be modified. The variation process, the 'mutation' generates a series of new transients similar to the original one but varied a little. So a statistical approach to the scattering of the model parameters is implemented. The prediction of local responses based on calculated or measured transfer functions (from the interface to relevant local responses) can be employed in order to reduce testing time.

This approach has been defined for testing large space structure (e.g. ARIANE 4/5 satellites) and is the very first step into this direction. IABG and DASA/ERNO (Bremen) have developed a software package for the 'mutation' process of Figure 2. In the very next future we will perform experiments with a test dummy structure for verification of the procedures⁵.

3 Test Facility for Multi-axis Transient Testing

In comparison with a single-axis shaker a servo-hydraulic multi-axis vibration test facility is a high complex dynamic system. A detailed presentation of how to design it certainly would be beyond the scope of this paper. Several subsystems are state-of-the-art. Therefore in this section first the existing test facility at IABG will be presented. Afterwards those subsystems will be discussed in more detail, which are critical with respect to the over-all performance, especially if test with space-objects are envisaged.

3.1 The Multi-axis Vibrator HYMAS at IABG

IABG has built the first version of the HYMAS⁶ test facility 1975, see (ref. 2); it was the first such facility in Europe. The configuration of the today existing facility which is shown in Figure 3 has been established during the last 5 years. IABG has performed over 650 qualification tests with both versions.

The table of the test facility is a welded steel construction with a mass of 4348 kg and the lowest structural resonance above 100 Hz. The outer dimensions of the table are 4.1 m × 3.2 m and the fixation area is 2.5 m × 2.0 m. The vertical actuators (z-direction) have a stroke of ±50 mm and a nominal force of 100 kN. In the horizontal plane three

⁵ A detailed presentation of this new technique, would be beyond the scope of this paper and is devoted to another publication to follow; the method and software have been developed in the course of a study financed by DARA, the German Space Agency.

⁶ HYdraulic Multi-Axis Shaker.

actuators with ± 125 mm stroke are attached, one in the x-direction with 250 kN force and in the y-direction two with 100 kN. All actuators are connected to the table and to the foundation by ball joints with PTFE coating. The whole facility is mounted on a seismic foundation with about 500 tons and a resonance at about 1 Hz. With the empty table vertical accelerations up to 80 m/s^2 and up to 40 m/s^2 in the horizontal directions can be reproduced depending on the frequency contents of the signal. The more mass the test object has, the lower the accelerations are, which can be applied to it; IABG has already tested objects with about 10 tons, the design payload is 4 tons. This test facility is presented in this paper as an example and had been used for obtaining the test results in section 4.

3.2 Mechanical and Hydraulic Equipment

With respect to the over-all performance of a multi-axis vibration test facility the following effects must be considered:

- **Dynamics of the table structure:** Usually the control concept to be discussed later assumes the table *rigid*, what means that the table has no eigen mode within the test frequency range. If this is not valid the modes of the table could be compensated by the design of the control system. The better solution certainly is to design the table structure properly.
- **Backlash and friction of the joints:** Both effects are strong non-linearities, which cannot be linearized (step functions). They cause non-linear dynamic behaviour of the control system e.g. limit cycles and instability. Therefore the choice of the controller parameters is restricted to a — often very small — stable region within the parameter space. Especially the over-all gain is limited strongly. The ideal joint would have no backlash, no friction and high stiffness; in reality a compromise must be found, which is quite difficult as all available variants — coated ball bearings, roller bearing and hydrostatic bearings — have their individual disadvantages. The higher the upper end of test frequency range is, the more this problem causes difficulties.
- **Friction of the actuators:** In principle here the same arguments as before are valid; but the today available actuators with hydrostatic bearings solve the problem sufficiently. For lower frequencies also actuators with sliding sealing (reduced friction) can be considered.
- **Signal distortions caused by the servo valves:** Due to the hydrodynamic processes in the different stages of the servo-valve and in the actuator the relation between servo valve input and the actuator acceleration is non-linear; this causes the well-known signal distortions as random-like noise and harmonics. This is especially true for three-stage servo valves with nozzle-flapper pilot stage, which often are used. Only careful design of the servo valve itself and optimization of the actuator control circuits can minimize this problem.

3.3 Control System

The automatic control system of a multi-axis test facility has several levels, see Figure 5, which are nested:

1. controllers for spools of the servo valves,
2. actuator controller,
3. the table controller,
4. off-line iteration⁷.

The first three layers establish the automatic control system, whereas the off-line iteration is a software to prepare the drive signals, see section 3.4.

3.3.1 Spool controller

Three-stage servo valves and modern two-stage servo valves employ an inductive sensor to measure and a special controller to control the movement of the spool. These controllers have significant influence to the dynamics and linearity of the servo valve. Therefore they must be adapted very well to the individual valve on a special test

⁷This technique is in the American literature often called 'Digital Control' or 'Closed-Loop Control', which can be misunderstood, because the 'control' is done off-line and not in real-time.

facility of the valve manufacturer. Only small modifications of this 'optimal' adjustment are allowed in the application for stable operation. The control law itself is quite simple; often PD-control is used. Usually these controllers are implemented as analog circuits often integrated together with the power amplifier in the servo valve housing. So they can be considered as part of the servo valve.

3.3.2 Actuator controller

The next layer of the control system is the actuator controller, which has to ensure that the actuator displacement and acceleration follow the specified signals. The choice of the structure of this controller and the setting of the related parameters offers a lot of possibilities to influence the over-all dynamics of the test facility. In order to achieve the desired accuracy and bandwidth necessary for testing space objects the following properties should be implemented:

1. feed-back and/or feed-forward of a subvector of the state vector of the actuator rod, usually displacement velocity and acceleration; if not all these signals are available from the measurement system in the required accuracy they can be obtained from an observer,
2. compensation of poles of the actuator e.g. the oil-spring/mass resonance and those due to the elasticity of the actuator housing or the joints,
3. compensation of poles of the payload, especially if they are weakly damped.

This concept involves only linear control techniques, as for them a lot of powerful design tools are available. Experimental investigations and numerical simulations, see (ref. 17, chapter 3), have shown that for usual configurations of multi-axis test facilities these linear control concepts provide a sufficient performance if they are applied correctly; this is especially true, if the relevant parameters are well-adapted to the actual test object.

Especially the last item can be a very critical task, as this cannot be done for each actuator alone due to the cross-coupling of all actuators, and due to the sensitivity to parameter changes.

Certainly non-linear control techniques as gain scheduling or model following offer some possibilities to achieve better performance. But we think that the application of these much more complicated techniques should be reserved for future improvements.

3.3.3 Table controller

The most important — and most complicated — of the control system of a hydraulic multi-axis vibration table is the table controller. It is a multiple-input-multiple-output system, which has to perform the following tasks:

1. transformation of the command vector for the six rigid body degrees-of-freedom of the table to the individual command input for each of the n_a actuators. In the hypothetical case of an ideal actuator controller (which would ensure a very accurate reproduction of each actuator input) this transformation will be only a linear(ized) kinematic transformation, which is quite simple for $n_a = 6$. In the case of $n_a > 6$ this transformation is not unique and therefore additional assumptions (e.g. "rigid table") or balancing techniques are necessary (force balancing),
2. compensation of the cross-coupling between the actuator due to the kinematics of the actuator arrangement,
3. compensation of the typical multi-axis dynamic effects known as "overturning moments" and "off-center load moments", which are due to the fact that the line of action of the actuators does not go through the over-all center of gravity of test facility and test object.

Our investigations, see (ref. 17, chapter 3), have shown, that here also linear approaches lead to a quite good performance. The kinematic transformation implements only linearized kinematics due to the very small possible angular displacement of the table. In the usual case of more than 6 actuators one has to use pseudo-inverse techniques, see e.g. (ref. 18) to get the transformation matrix. In order to compensate the dynamic effects (item 3) we have found out a reduced inverse model of the test facility to be sufficient, which includes only the linear dynamics of the rigid (loaded) table excited by the actuator forces. From this model and the desired table state the required force for each of the actuators can be calculated; they can be used for an additional feed-forward or feed-back loop which is superimposed to the position/acceleration control of the table.

Essential for good performance here is the adaptation of the control parameters to the individual test object.

The complexity of the over-all system to our opinion does not allow to merge the actuator controller and the table controller into one MIMO-control system due to the difficulty how to design such a system.

3.3.4 Implementation as digital system

In both preceding sections parts of the control systems had to be adapted to the special test circumstances. With a control system implemented in analog electronic this adaptation is a very complicated task. With respect to the quality requirement applicable for space tests it is also a very critical task. Therefore best would be to implement both the actuator controller and the table controller as digital control system calculating the servo valve input in real-time. For a test frequency range of 100 Hz at least a sampling frequency of 2 kHz is necessary, which implies that all data acquisition, computation and data output within the control loops must be done within a frame time of 0.5 ms.

The recent development of computer hardware allows now the implementation of such a real-time system with acceptable costs. In principle several hardware approaches are possible: standard multi-processor systems (e.g. based on VME-bus), signal processors or transputer networks.

After some preliminary investigations IABG decided to implement the digital control system⁸ on a transputer network containing 11 T 800 transputers (ref. 19) (for computational work) and 6 T 222 transputers (connected to D/A- and A/D-converters). The host system is a personal computer (industry standard) on which the user interface is implemented. The system has been built up and is now under test; finally it will replace all analog parts of the existing control system except the signal amplifiers and filters.

The control software includes all elements discussed in sections 3.3.2 and 3.3.3 and has been written in OCCAM 2 (ref. 20). The sampling rate is 2 kHz. The communication structure is shown in Figure 6. This structure has been chosen base on a detailed analysis of the times needed for computation and communication of the different processes working in parallel. Only a good balancing of both leads to acceptable performance.

3.4 Off-Line Iteration

The *off-line iteration* is a software which builds up some sort of *off-line 'outer control loop'*, see Figure 5. The approach is to modify the input signals to the MIMO-System by pre-filtering with the inverse dynamics of the loaded test facility and to minimize the errors between specified and measured signal iteratively.

Several software systems for off-line iteration are today available on the market, e.g. (ref. 21, 22, 23, 24). They all are based more or less on theoretical work done in USA (ref. 25, 26). Only few extensions of this primary approach have been discussed, see e.g. (ref. 27). Up to now a thorough theoretical investigation of the procedure and a proof of its convergence are not available. As an Example IABG's software system ISA, see (ref. 24), will be used; it consists of two independent steps:

1. Identification of the transfer function matrix H by means of dividing the cross power spectral densities between the components of the input vector (exciting signal) and the components of the output vector (measured signals) by the components of the auto power spectral densities of the input signals, see Figure 7; this yields under some additional assumptions a *linear approximation* in the frequency domain of the non-linear dynamics of the loaded test facility.
2. Iteration for a transient signals by using *Newton's method* with the transfer function matrix from the identification step as approximation for the Jacobian matrix of the iteration function at a set of discrete frequency points. This means that the Fourier transform of the error between the measured and the desired (transient) output vector is multiplied by the inverse $I := H^{-1}$ of the transfer function matrix, the so called impedance function matrix, and added — multiplied by a factor $0 < \alpha \leq 1$ — to the last iterated input vector, see Figure 8. This is done for all frequency points to get a Fourier transform of a new input vector. The corresponding input vector in the time domain yields a smaller error between the system response and the desired output — convergence presumed. Depending on the desired accuracy, the value of α and test object dynamics 2 ... 10 iteration steps are necessary.

⁸This is one part of a current study financed by DARA, the German Space Agency.

This procedure is state-of-the-art in controlling complex test facilities and has turned out to be quite successful under certain circumstances. Although an elaborated automatic on-line control system (actuator controller and MIMO-system) will be able to minimize the differences between the desired and reproduced test signals, an off-line adaptation of the test signals to the specific characteristics of the test object (mass, moment of inertia, height of center of gravity, stiffness etc.) will be necessary — at least as supporting tool. This is especially true if the dynamic behaviour of the test object has an essential influence on the overall dynamic of the test arrangement as e.g. in the case of structural resonances or non-linear dynamic behaviour. Any on-line method, e.g. model following has to cope with exactly the same problems — and in addition with the stability problem.

In any case, the *main advantage* of the off-line iteration procedure is, that between the individual iteration steps the operator can have a look at intermediate results, judge about the convergence and the loading of the test object — and decide to go on or to modify the procedure in a suitable sense. This would not be possible in any on-line procedure; here all control is done by an automatic system and no operator interaction is possible to avoid overload of the test object or instability.

During a recent study with the DFS/STM (ref. 28) it was demonstrated that multi-axis transients can be reproduced with almost the accuracy required for the qualification of space objects by a multi-axis hydraulic vibration test facility using ISA. But some problems still exist and have to be solved by improvements of the iteration procedure. These are ensuring the convergence from one side (from below), reduction of iteration steps (acceleration of convergence) and optimization of preprocessing steps considering the transfer and impedance function.

4 Some Test Results

Figure 9a) shows the time history of a 6-DOF test transient derived from ARIANE-4 flight measurements. The physical event behind it is the unsymmetric burnout of the fluid boosters (PAL-D), which is a design load case for AR-4 payloads. Similar transients are caused during launch by burn-out of main motor, gusts, separation of stages and blast-off of fairings. The transient in Figure 9a) has been derived by the procedure from Figure 1 for the structural model of the german communication satellite DFS-Kopernikus. The DFS/STM was investigated by IABG during a study financed by BMFT⁹, see (ref. 28).

The transient LC2 has quite strong excitation in the first 2 DOF, which represent the horizontal translations, whereas in the other components only relatively small signals appear. This causes that the cross-talk of the strong DOF to the smaller ones is nearly in the same order of magnitude as the specified signal. This is a problem for the reproduction and can only be solved with the ISA-procedure in section 3.4. The result of the 9th Iteration is shown in Figure 9b). The coincidence is quite good. So it is demonstrated, that even difficult transient signals can be reproduced with a multi-axis vibration test facility. The results of measurements of local responses (e.g. antenna dummy) have also shown clearly, that all considerations discussed in section 2 are valid.

References

- [1] C. J. Dodds und J. D. Robson. Road Simulation. *Journal of Automotive Engineering*, 3(4) 17-19, 1972.
- [2] W. Mercklinghaus et al. Computer Controlled Hydraulic Earthquake Simulation for Testing H.V. Switch Gear. *Siemens Review*, XLIV(9), 1977.
- [3] Multi-Axis Vibration Test. Technical Data Sheet IABG.
- [4] Vibration Test Facility Juelich — MAVIS 1. Technical Data Sheet DLR — Institut für Aeroelasticity.
- [5] C. J. Dodds. The Laboratory Simulation of Vehicle Service Stress. *ASME Journal of Engineering for Industry*, 391-398, 1974.
- [6] D. D. Styles und C. J. Dodds. Simulation of Random Environments for Structural Dynamics Testing. *Experimental Mechanics*, 16(11) 416-424, 1976.
- [7] B. W. Cryer, P. E. Nawrocki, und R. A. Lund. *A Road Simulation System for Heavy Duty Vehicles*. SAE Technical Paper 760361, Feb. 23 1976.

⁹German ministry for research and technology.

- [8] C. J. Dodds. Environmental Testing Under Random Loading. In: *Symposium on Service Fatigue Loads Monitoring, Simulation and Analysis*, MTS Systems Corporation, November 1977.
- [9] K.-H. Knoche und K.-P. Weibel. Mehrkomponenten-Karosserieprüfstand zur Simulation von Betriebsbeanspruchungen unter Berücksichtigung freier Massenkräfte. *ATZ Automobiltechnische Zeitschrift*, 82(6) 329–334, 1980.
- [10] G. Jacoby. *Mechanical Testing in the Automobile Industry*. Technical Report, Carl Schenck AG, Darmstadt, 1985.
- [11] W. Raasch. Rollprüfstand zur Verifizierung der Theorien. *ZEV-Glasers-Annalen*, 106, 1982.
- [12] Roller Test Facility Munich — Dynamic Drive Simulator for Rail Vehicles. Technical Data Sheet IABG/DB.
- [13] Richard C. Stroud und Hamma George A. Multiexciter and Multiaxis Vibration Exciter Control Systems. *Shock and Vibration*, 22(4) 18–28, April 1988.
- [14] W. Douglas Everett und Thomas M. Helfrich. Triaxial Vibration System. *Shock and Vibration Bulletin*, 55, Part 2(6) 1–15, June 1985.
- [15] George A. Hamma und Richard. C. Stroud. Closed-Loop Digital Control of Multiaxis Vibration Testing. In: *Proceedings of the Institute of Environmental Sciences, 31st Annual Technical Meeting, Las Vegas, 29.4. – 2.5 1985*.
- [16] S.A. Foster und Ceng Miere. Electro-Dynamic Multishaker System. In: *Proc. 34th Ann. Techn. Meeting*, S. 224–227, Inst. of Environmental Sciences, 1988.
- [17] G. Lachenmayr. *Investigations on Upgraded Offline Iteration, Improvement of Actuator Control, Safety Switch-Off Values and Experimental Investigations with Hydraulic Components — Final Report*. Technical Report B-TF 2887, IABG, 1992.
- [18] T. N. E. Greville. Some Applications of the Pseudoinverse of a Matrix. *SIAM Review*, 2(1) 15–22, January 1960.
- [19] *IMS T800 Transputer - Data Sheet*. Inmos, 1989.
- [20] C. A. R. Hoare, Hrsg. *Occam 2 Reference Manual*. Prentice-Hall, (UK), 1988.
- [21] Performance Specification for Multiexciter Vibration Control Systems. Data Sheet Synergistic Technology Incorporated, Santa Clara CA.
- [22] RPC Remote Parameter Control. Firmenbroschüre MTS.
- [23] ITFC Ein Computersystem für die Simulationstechnik. Firmenbroschüre Carl Schenck AG, Darmstadt.
- [24] Seiler. *Iterative Steuersignalanpassung (ISA) — Programmdokumentation*. Bericht B-TF-V 222, IABG, 1985.
- [25] D. K. Fisher. Theoretical and Practical Aspects of Multiple-Actuator Shaker Control. *Shock and Vibration Bulletin*, 43(3) 153–174, Sept. 1973.
- [26] D. K. Fisher und Posohn M. R. Digital Control System for a Multiple-Actuator Shaker. *Shock and Vibration Bulletin*, 47(3) 77–96, Sept. 1977.
- [27] Volker Tews. Iterative Drive-Signal Determination for Nonlinear and Deadtime Plants. In: *Intern. Conf. on Control*, IEEE, Oxford, April 1988.
- [28] G. Lachenmayr, W. Raasch, und W. Saad. Multi-Axis Vibration Simulation in Space Structures — Experiments with DFS/STM. In: *International Symposium on Environmental Testing for Space Programmes, Noordwijk (ESA SP-304)*, ESA/ESTEC, September 1990.

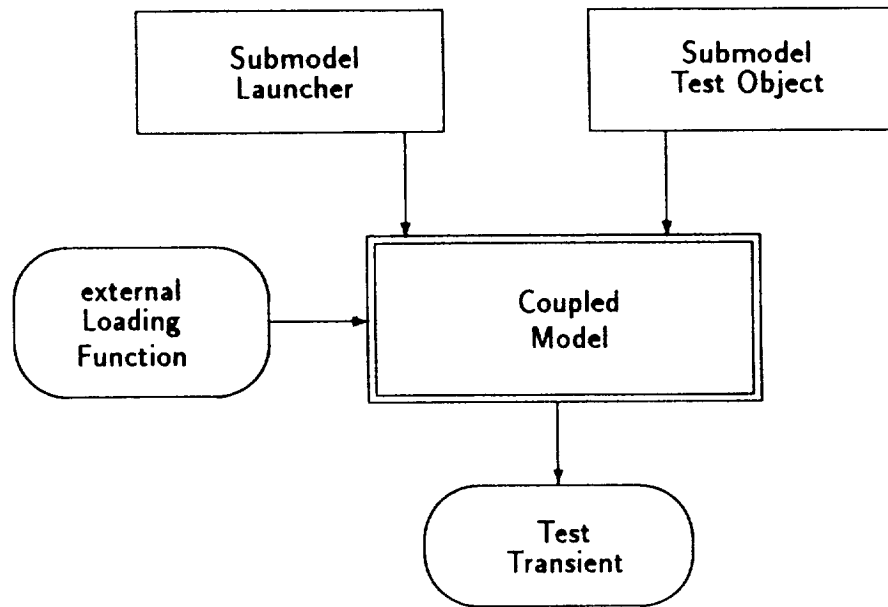

Figure 1: Derivation of test transients by 'coupled analysis'

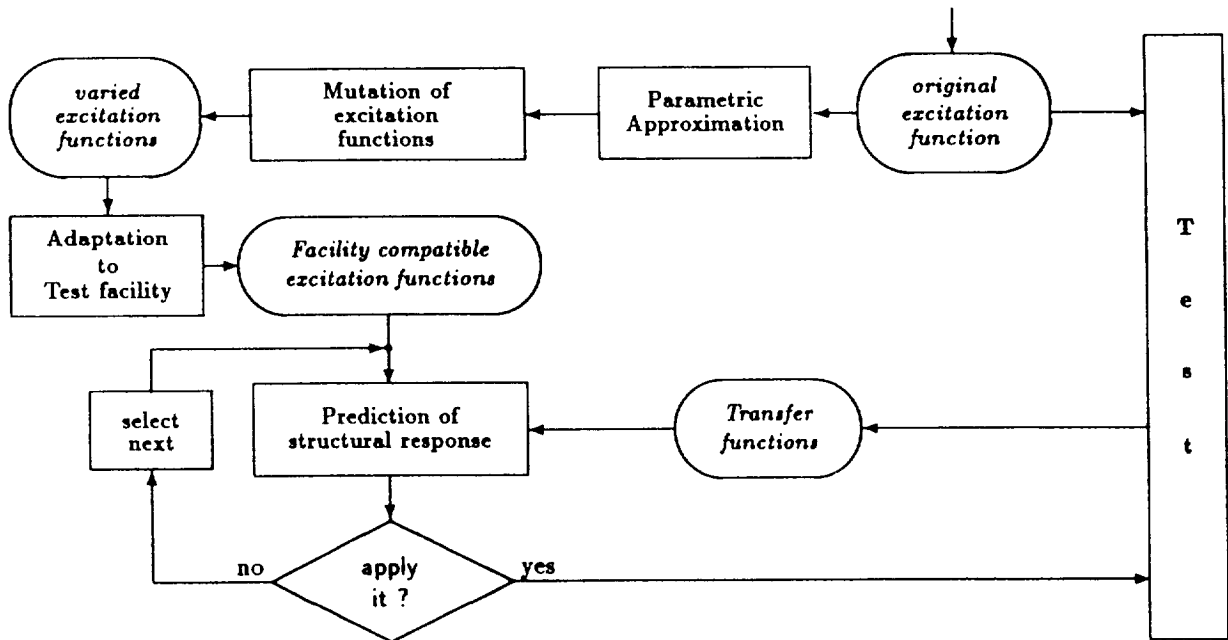

Figure 2: Randomization of test transients by mutation

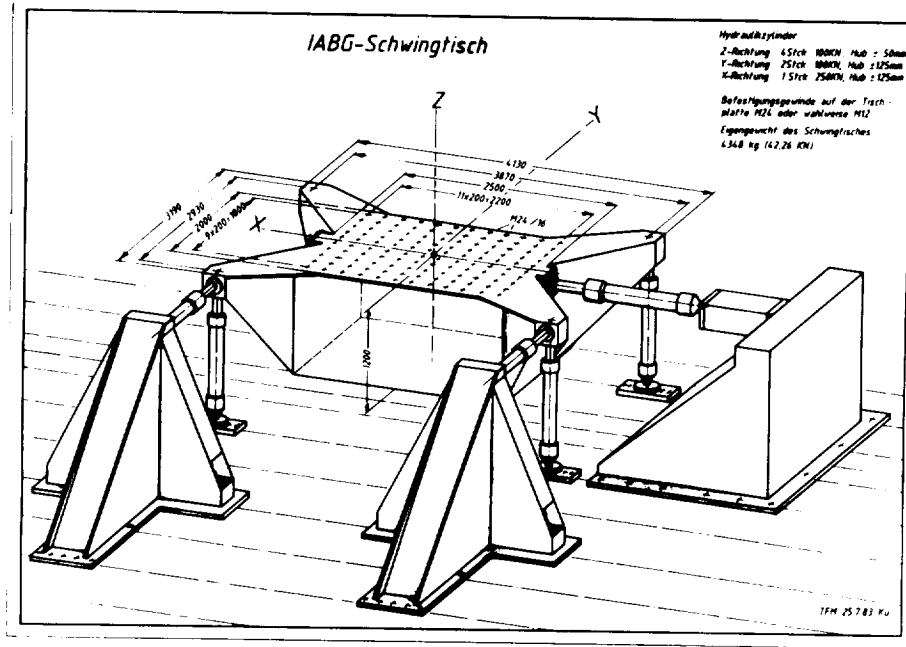

Figure 3: Schematic drawing of the IABG multi-axis test facility

ORIGINAL PAGE
 BLACK AND WHITE PHOTOGRAPH



Figure 4: IABG multi-axis test facility with DFS/STM

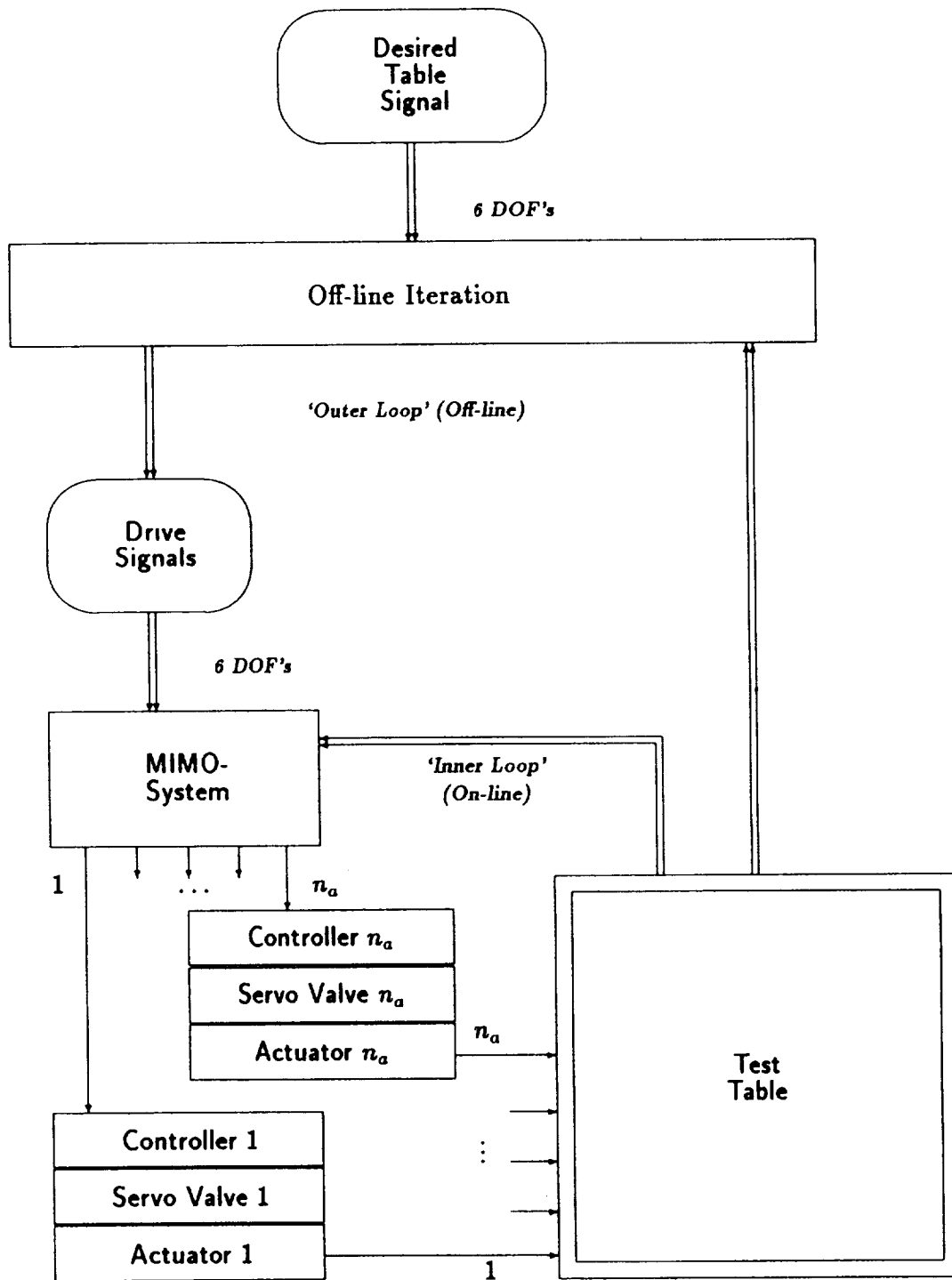

Figure 5: Block diagram of the Over-all Control system

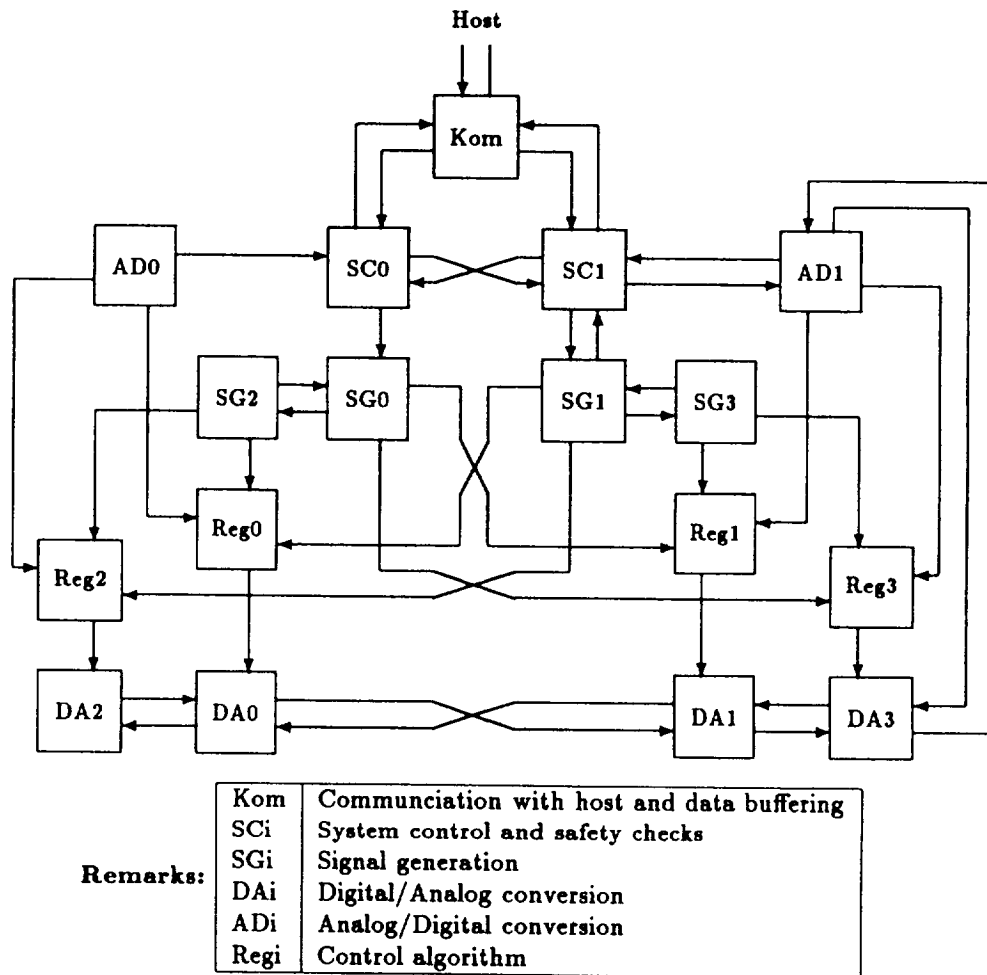
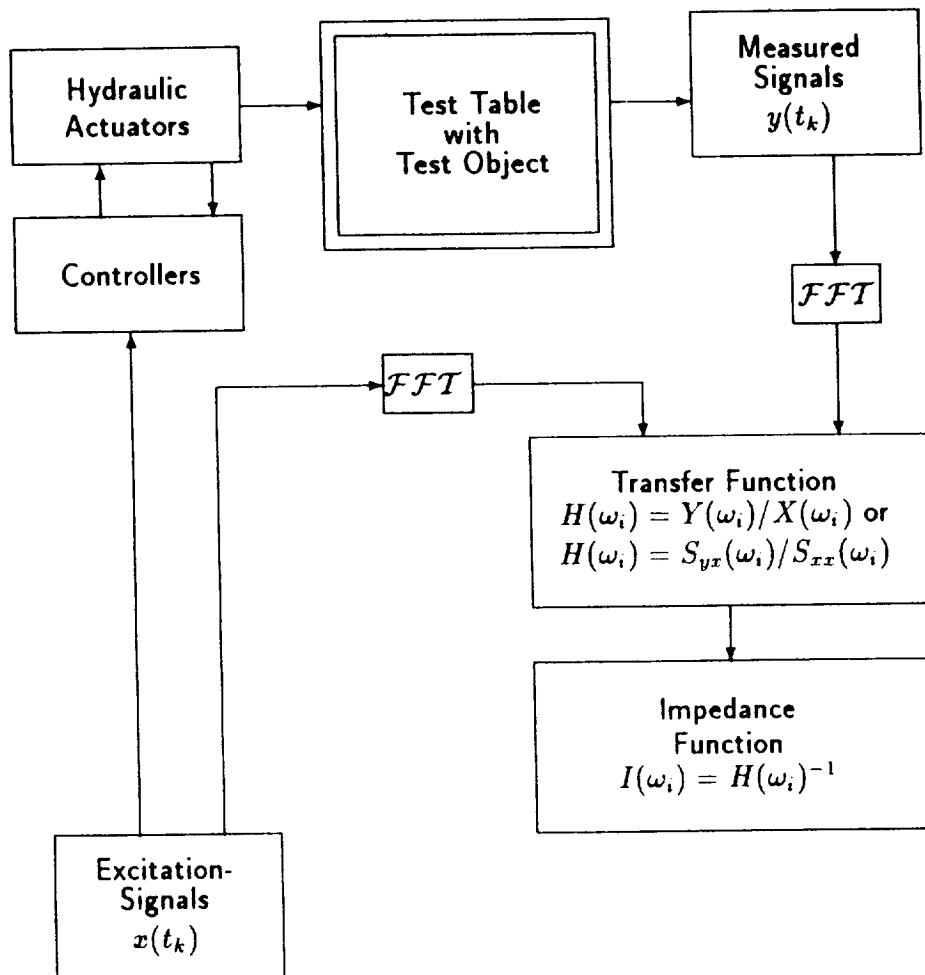

Figure 6: Communication structure of the transputer network used for the digital control system



Remarks:

FFT	Fast Fourier Transformation
$Y(\omega)$	Fourier transform of $y(t_k)$
$X(\omega)$	Fourier transform of $x(t_k)$
$S_{yx}(\omega_i)$	cross spectral density
$S_{xx}(\omega_i)$	power spectral density

Figure 7: Block diagram of the *Identification Step* of ISA

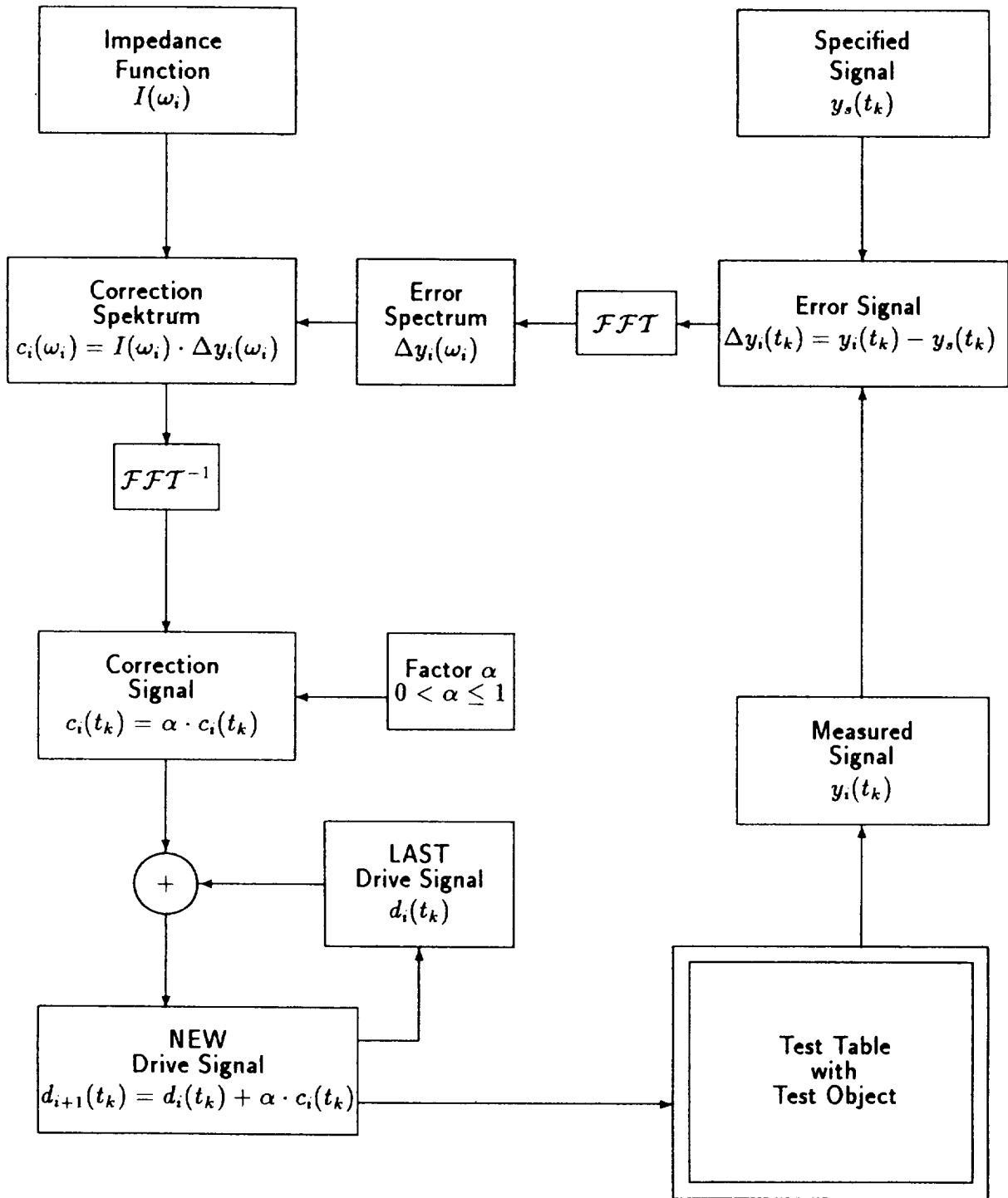

Remarks: *FFT* — Fast Fourier Transformation

Figure 8: Block diagram of the *Iteration Step* of ISA

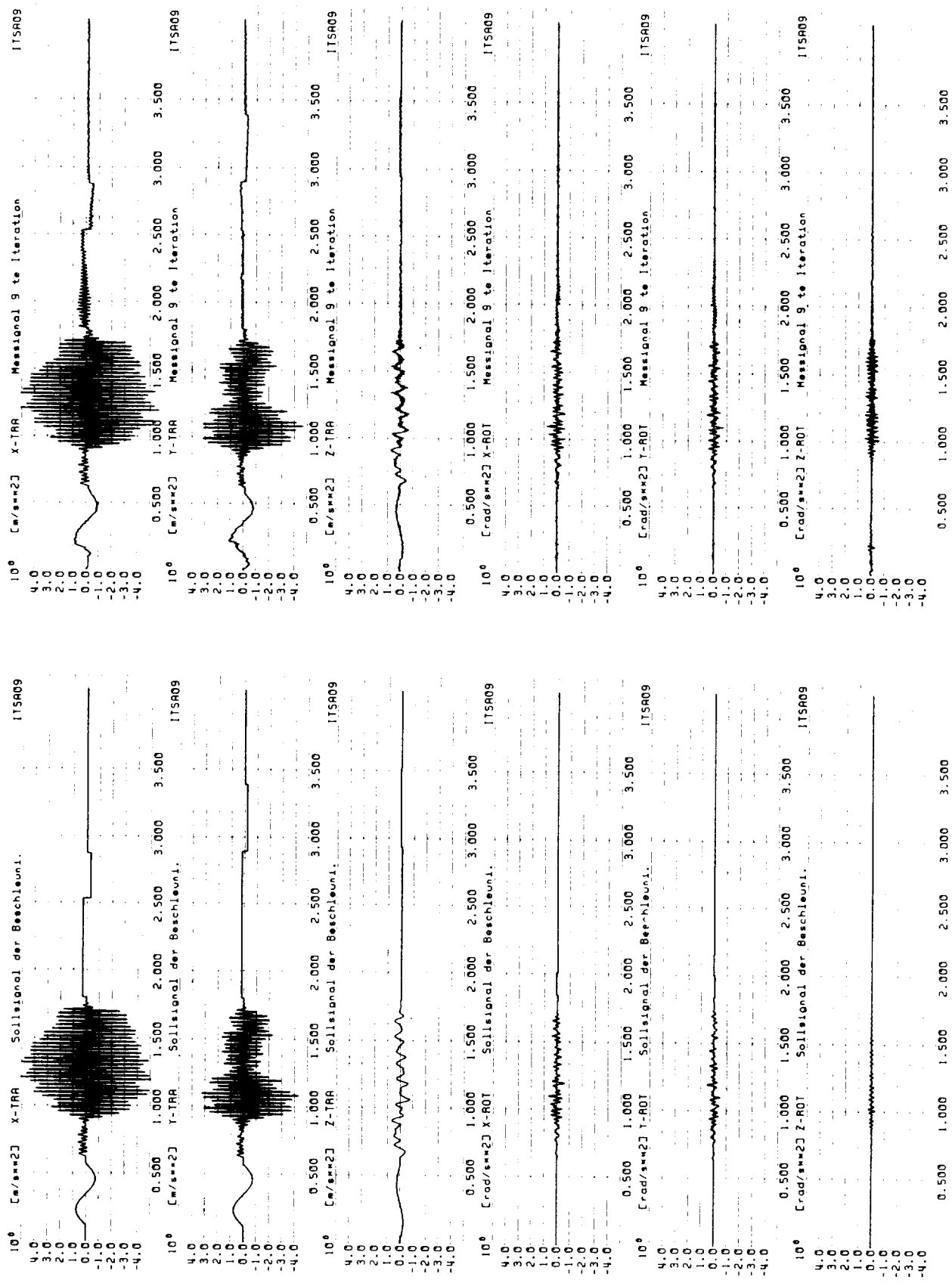

a) Specified Transient

b) Result Iteration 9

Figure 1: 6-DOF test transient LC2 of DFS/STM