

N 9 3 - 1 5 6 0 8**A NEW APPROACH FOR DATA ACQUISITION AT THE JPL SPACE SIMULATORS***

Terry C. Fisher
*California Institute of Technology
Jet Propulsion Laboratory
Pasadena, California 91109*

ABSTRACT

In 1990, a personal computer based data acquisition system was put into service for the Space Simulators and Environmental Test Laboratory at the Jet Propulsion Laboratory (JPL) in Pasadena, California. The new system replaced an outdated minicomputer system which had been in use since 1980.

This new data acquisition system was designed and built by JPL for the specific task of acquiring thermal test data in support of space simulation and thermal vacuum testing at JPL. The data acquisition system was designed using powerful personal computers and local-area-network (LAN) technology. Reliability, expandability and maintainability were some of the most important criteria in the design of the data system and in the selection of hardware and software components.

The data acquisition system is used to record both test chamber operational data and thermal data from the unit under test. Tests are conducted in numerous small thermal vacuum chambers and in the large solar simulator and range in size from individual components using only 2 or 3 thermocouples to entire planetary spacecraft requiring in excess of 1200 channels of test data. The system supports several of these tests running concurrently.

This paper describes the previous data system and reasons for its replacement, the types of data we acquire, the new data system hardware and software, the criteria used to design the new system, and the benefits obtained from the new system including information on tests performed to date.

* The research described in this paper was carried out by the Jet Propulsion Laboratory, California Institute of Technology, under a contract with the National Aeronautics and Space Administration.

INTRODUCTION

The Jet Propulsion Laboratory (JPL) in Pasadena, California is responsible for the management of unmanned planetary spacecraft for the National Aeronautics and Space Administration (NASA). As part of this task JPL has extensive laboratory facilities (The Environmental Test Laboratory and Space Simulators) for performing thermal vacuum and space simulation tests on components, assemblies and complete spacecraft for design verification and flight qualification.

An integral part of these facilities is the data acquisition system which is used to acquire thermal test data from several tests running concurrently, process the data, perform computations on the data, check limits, control test item heaters, archive the data and present the test data in various formats; all in real time.

A new data acquisition system which can perform the above functions was put into service in August, 1990 to replace a minicomputer based data system which had been in use since 1980. This new system uses personal computers and database management software operating on a network across three buildings. The new data acquisition system utilizes state-of-the-art computer and networking technology with increased reliability and provides a graphic user interface which increases productivity and decreases operator training time.

DATA ACQUISITION REQUIREMENTS

The solar/thermal/vacuum testing activities at the JPL Environmental Test Lab and Space Simulators require many different types of data to be acquired, processed and stored in one data system. Data is acquired for both facility operations and test article monitoring. The data is used for real time decision making and for post test analysis.

The types of data that are recorded for facility operations include chamber cold wall temperatures, vacuum gage outputs, solar radiation intensity and temperature controlled quartz crystal microbalance (TQCM) frequency and temperature signals for contamination monitoring. The amount of facility data to be acquired depends on the chamber being used. The small (.7 by 1.3 meter) thermal vacuum chambers may require only 5 or 6 channels of data while the large (8 by 26 meter) solar/thermal/vacuum chamber requires over 170 channels of data to be recorded just for facility operations.

The principal types of data that are acquired from test articles include temperature from thermocouples and Platinum Resistance Thermometers (PRT), and power supply voltage and current outputs. A typical flight spacecraft test can require over 900 temperature and voltage measurement channels while a small component test may only need a few thermocouple channels.

Most of the thermal vacuum tests performed at JPL also require the use of numerous channels of computed data such as averages, deltas, rate of change, power calculations and conversion of vacuum gage voltage output to exponential torr values.

THE OLD SYSTEM

The previous data system was based on a minicomputer that utilized mid 1970s hardware technology and operated with a 1966 version of FORTRAN IV. This was a fine system in its day; however, as the size of spacecraft grew, so did the required amount of data that had to be recorded during space simulation testing.

During testing of the *Galileo* flight spacecraft in 1988, the system was so overloaded, (1200 channels of data were required) the processing was anything but real time, and the 50 megabyte disk drive was filled to capacity before the end of the test.

Other factors that led to the decision to retire the old system were that replacement parts were becoming difficult to obtain, and software maintenance was complicated by the lack of original source code for some parts of the system. Also the user interface was anything but "friendly" and new users required considerable training on the system before performing simple tasks.

REQUIREMENTS FOR THE NEW SYSTEM

When it was decided to retire the minicomputer system, the first task was to set down a list of requirements for the replacement data acquisition system. The major requirements for the new system were reliability, maintainability, expandability, flexibility, large data storage capacity and a graphical user interface.

Reliability of the system is extremely important since chambers run 24 hours a day, seven days a week, and the loss of test data is unacceptable. Reliability is important for both hardware and software, so only products of proven reliability would be considered for implementation into the new system design.

Maintainability is also very important as downtime during a test can be very costly to the project in terms of both dollars and schedule. To provide for ease of maintenance, the new system would use equipment from the same manufacturer for interchangeability and commercial off-the-shelf software wherever possible.

Expandability is necessary to provide for meeting the future data acquisition requirements of larger, more complex spacecraft. This would be provided by using an open architecture which would allow for the addition of more input and output equipment. Also, the software should not limit growth but have a platform on which to expand.

Flexibility is required to allow several tests to run concurrently at different locations. Since tests are both large and small, and start and stop at different times, it is necessary for the system to be able to manage all this activity transparently to the data acquisition and processing tasks.

The data storage capacity must be large enough to accommodate large tests which can run as long as 30 days, around the clock and require 1200 data channels. The data storage system must also have adequate redundancy to ensure no loss of test data.

The final major requirement is a graphical user interface. Since the data acquisition system is used by personnel of varying degrees of computer expertise, the design of the user interface has to be compatible with the lowest level user and not be cumbersome to higher level users.

THE NEW SYSTEM

The replacement data acquisition system, S³ (Space Simulator System), was designed and integrated at JPL, using third-party hardware and software and custom software which was written by JPL software and systems engineers. The design makes use of a fault tolerant Client/Server Architecture to distribute the data processing among several personal computers (PCs) and a local area network (LAN) was implemented across the three buildings which comprise the Environmental Test Laboratory and Space Simulators. By using the client/server technology, the data acquisition and processing tasks are distributed to multiple personal computers, and no one computer is ever overloaded and processing speed is always at maximum.

The S³ design makes use of proven commercial off-the-shelf hardware and software to provide for interchangeability, expandability and maintainability.

The major hardware elements of the data acquisition system are the analog input device, the PC controlling the analog input device, the workstation PC, the output peripherals, the file sever and the local-area-network which ties all the equipment together. See Figure 1.

The major software components of S³ are the networking, database management, communications, graphics and memory management software packages from various software publishers and the custom software that was written at JPL to integrate the total system.

Major Hardware Components

Computers

All computers in the system are *Compaq 386 DeskPro* machines, manufactured by the *Compaq Computer Corporation*. The PCs are divided into three categories: file servers, controllers and workstations. By using computers of one type and from the same manufacturer, interchangeability throughout the system is maintained.

Space Simulator System Network Configuration

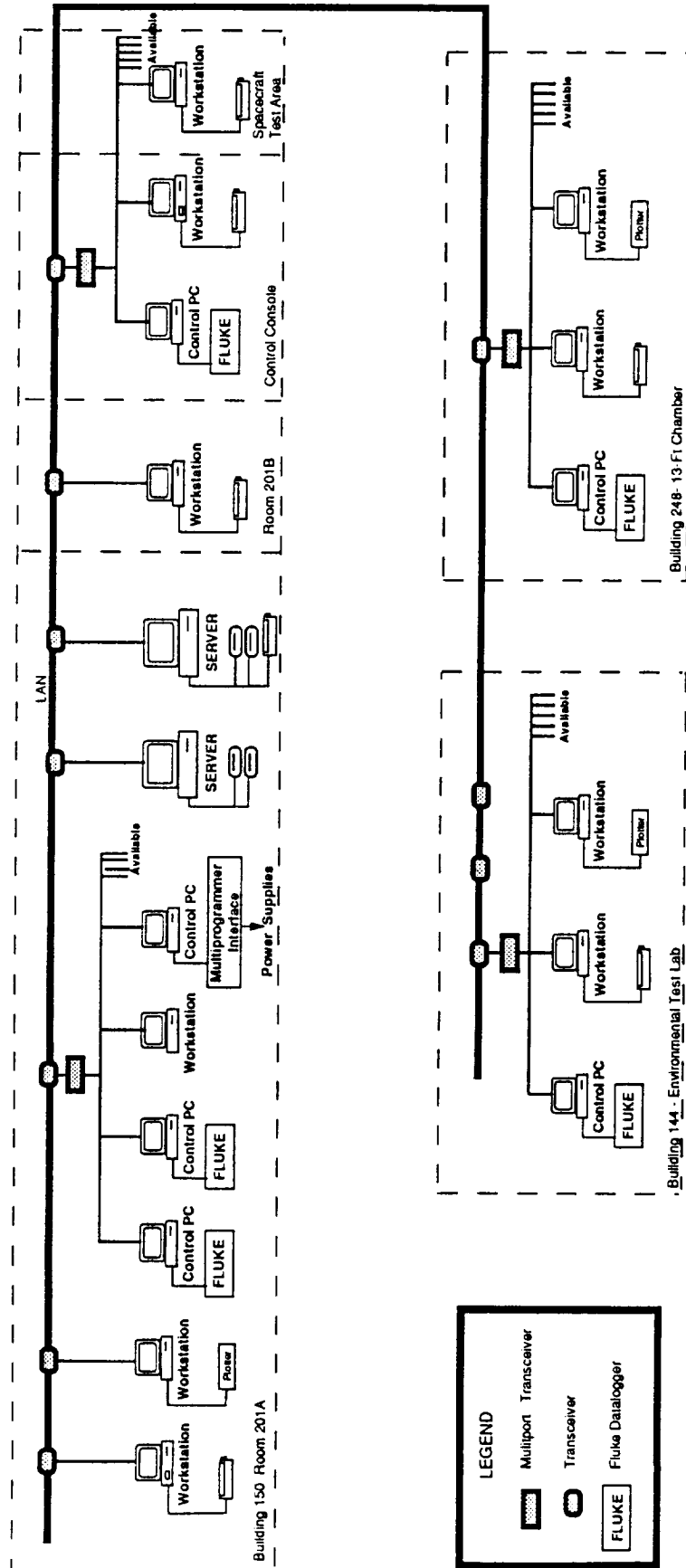

This is a typical configuration for operations in the 25 Ft Space Simulator, Building 150, and for tests running in smaller chambers in other facilities.

Figure 1.

File Server

The two file server PCs are the heart of the networked data acquisition system. The file server stores all the application software, controls all network activity, provides storage for all test data and manages all of the printed and graphical output of the system.

In the S³ configuration, the file servers are 386, 33-MegaHertz (MHz) computers with 10 MegaBytes (MB) of random access memory (RAM) and 1.3 GigaBytes (GB) of hard disk storage. The hard drives are actually two 650-MB units which can be configured to operate as one 1.3 GB unit or two 650-MB units per file server, depending on the amount of redundancy desired.

Control PCs

There is one PC to control every data-acquiring device (typically a data logger) on the system. The control PC is connected to its data logger by either an IEEE-488, or a RS-232 interface. The control PC is used to program the data logger, initiate scanning, check limits of the data and perform some of the computations on the data. The control PC also stores the test data on its internal hard drive, providing an additional copy of the data that is also saved on the file servers. During operations, the keyboard of the control PC is locked to prevent accidental interference with the acquisition process and the computer's monitor provides a continuously updated display of test status and limits exceeded.

The control PCs are 33 MHz machines with 4 MB of RAM and a 330-MB hard drive. The computer's standard serial port is used for RS-232 communications, and for IEEE-488 communications a General Purpose Interface Bus board is installed in the control PC expansion slot.

Workstations

As its name denotes, the workstation is the PC that is used for most of the human interface work on the system. The workstation is where the system operators and test personnel set up tests, start acquisition, look at different data reports and perform system maintenance. The workstation is also used for transferring data to floppy disk and magnetic tape for off-line data reduction and data storage. The number of workstations that are used to support a test is dependent on the size of the test. Smaller tests require only a single workstation for the thermal engineer to look at data displays but a large test in the solar/thermal/vacuum chamber might require as many as 7 workstations to allow all of the test team and facility operators to view data, produce plots and perform the tasks associated with a large test.

In the S³ system configuration, the workstations are 20 MHz computers equipped with 5 MB of RAM and a 110-MB hard drive. Two of the workstations are fitted with 135-MB magnetic tape units for archiving test data and backing up system software files.

Analog Input Equipment

The system uses model 2286A data loggers from the *John Fluke Manufacturing Co.* as the primary analog data input device. These data loggers scan transducers, perform engineering unit conversions and transmit the data to the control PC.

The *Fluke* model 2286A data logger has the ability to measure a full range of analog inputs, including 11 different types of thermocouples, DC voltages up to 64 volts without conditioning, PRT resistance, and frequencies from 2 Hz to 400 KHz. A single 2286A can scan up to 1500 channels.

Fluke 2240B data loggers are also used with the system; however, they are somewhat limited in the types of input signals they will accept.

The 2286A was chosen over other types of input devices because of its ability to act as a stand-alone data logging unit. Equipment that is designed to be operated strictly as a computer "front end" lacks the ability to be used to collect data independently of the host computer, should the host be out of service. Also in our test labs, some small tests do not always need the capabilities of the full data system, so operating with only a data logger can be more cost effective.

Because of the system design and modularity of the software that controls the input devices, just about any type of data logger or data scanning unit could be added to the system with only a minimum amount of reprogramming. The only programming required would be the addition of a new software module to support the new device.

Output Peripherals

There are numerous types of data output formats available with S³. There are various data display screens for the workstation monitors and several formats of hard copy reports and plots from printers and multi-color plotters.

The system uses laser printers, equipped with extended font cartridges for all hard copy reports. The laser printers are connected to the system via the parallel output port of a workstation but are accessible from any workstation on the network.

The plotted output is produced by multi-pen graphics plotters which are connected to the system through the workstation serial output port. These plotters have eight different color pens and provide good quality plots on either paper or transparency film.

Network Hardware

The Local Area Network (LAN) connects all the PCs of the data acquisition system together. The network is a thick ethernet consisting of a single coaxial cable which interconnects the three buildings of the Environmental Test Laboratory and Space Simulators. Attached to the coax cable are network transceiver units which act as part of the interface between a PC and the network cable.

Each PC has a network interface card installed in an expansion slot which completes the connection to the network. The network interface cards are either a NE2000 from *Novell Inc.* or a PCNIU card from *Ungerma-Bass Inc.* The two cards are essentially the same and can be used interchangeably with minor software modifications.

Also used in the system are eight-channel multi-port adapters which allow the connection of up to eight PCs to a single network cable transceiver.

In its present configuration, (see Figure 1) the LAN can support up to 38 PCs, however it would be possible to support up to 250 PCs by adding more transceivers. Conversely, a minimum system of only three PCs could be operated on a network to support one test.

Major Software Components

Network Management Software

All of the system hardware is networked under *Netware/386* from *Novell Inc.* The network management software controls the communications between all of the computers on the network. When a workstation or control PC needs information or requires data to update a display, the file server handles the request under the direction of *Netware*. This software functions similarly to an air traffic controller who is directing airliners on a very busy route, preventing collisions between all the airplanes on that route, and making sure every plane gets to its assigned destination. Another major function of the network software is its fault tolerant feature which automatically routes incoming test data to each of the file server hard disks. By this process, called "mirroring", duplicate copies of test data is saved on both 1300 MB disks, and should one drive fail, there would be no loss of data.

Other features of the *Novell Netware* are the print queue and tape backup utilities. The print queue manages all of the printed output of the system. Whenever a hard copy printout is called for or a graph is to be plotted, the job is spooled by the print queue and routed to the proper printer or plotter. The tape backup utility is used to backup system programs and to archive test data to tape for permanent storage.

Database Management Software

The database management software is the power behind the S³ data acquisition system. The total system is built around *FoxPro/LAN, 1.02*, Fox Software Company's dBase-compatible network database management software. *FoxPro*, a multiuser, relational database development environment, was used to develop all of the application programs used by the system. It was chosen primarily for its speed and advanced features for data storage, manipulation and presentation. The application programs to perform most of the system tasks are written in the *FoxPro* language.

Databases are used for everything from keeping track of test setups to storing test data. The system uses 34 different databases for test setup, and 6 databases for test data for each active test on the system. The system also creates numerous temporary databases each time a test is run for things such as plot files and limit reports.

Operating System

The operating system used by the PCs of S³ is *MS-DOS, version 3.31*. This was the latest version available when the system development began and the only operating system supported by both *FoxPro* and *Novell* at that time.

Communications Software

The software that is used to communicate between the datalogger and its control PC is *SilverComm* from *SilverWare, Inc.* This software package is a database compatible communications program that takes full advantage of the speed of *FoxPro* and the high baud rates of data transfer available with the *Fluke 2286A*. Through *SilverComm*, the system downloads channel programming to the datalogger and provides a path for data transfer from the datalogger to the control PC.

Graphics Software

The graphics and plotting software within the data acquisition system is *dGE*, produced by *Pinnacle Publishing Company*. This software package is specifically designed to create graphics from within a database program. The software provides for automatic scaling of both the X and Y axis, and produces high resolution plots of test data which can be sent from the workstation to both plotters and printers.

Memory Management Software

The memory utilization in the workstations and control PCs is managed by *Quarterdeck Extended Memory Management (QEMM 386 5.0)* software from *Quarterdeck Office Systems*. This software package is used to access high-memory addresses and to optimize the computer memory resources for *FoxPro*.

Custom Software

Over 45,000 lines of custom software code were written by the Software and Systems Engineers from the Institutional Data Systems section at JPL. This software code integrates the third-party software packages into a functioning system. Most of this code was written in the *FoxPro* language; however, some was written in assembly language. Over 260 individual program modules were written during the development of S³. The modularity of the custom software makes system enhancements and maintenance a relatively easy task for the software maintenance personnel.

Included in this custom software are 98 individual display screens and user interface screens that were designed for the system. These screens are used for data presentation, test setup, system operations and system maintenance. The system operates on a menu-driven format and makes use of numerous pop-up, choice-box and pull-down menus. Each screen has an associated help screen for user assistance.

The custom software development also made provisions for the numerous types of computed channel calculations required for the data system. Software for averaging data channels, computing deltas, determining maximum/minimum values from a group of channels and the conversion of ion gage output voltage to exponential Torr values required a considerable amount of programming effort.

PERFORMANCE RESULTS OF THE NEW SYSTEM

The new system has met or exceeded all of our initial design requirements and has proven to be an excellent choice for a data acquisition system. Once the capabilities of personal computers, database management and networking was fully understood by our instrumentation personnel, it became apparent that the applications were limitless. The cost savings in maintenance, reduced user training time and reduced test setup times have partially offset the cost for the system development.

The hardware has proven to be very reliable with only a few infant mortality-type failures during the first months of operation. The software has had some "bugs", as is expected with a new system, but because of its modularity and the advanced engineering put into the software design prior to actual coding, repairs have been made quickly with no test down time and no loss of data.

The criteria of flexibility and expandability have been met by the design of the hardware and software. We have recently added three PCs to the network to supplement the original 14 computers and have supported more tests running concurrently than we had ever anticipated. The software modularity has proven to be very beneficial as we have been requested to add several functions to the data processing and mathematical computations that were not part of the original design.

Operationally, the new system has proven to be a vast improvement over the old system. Because of the careful design of the graphic user interface, it takes only 2 or 3 hours to completely train an entry-level technician on basic system operations. A test setup which took 3 or 4 days to perform on the old system can now be completed in less than 8 hours with S³. Small tests of approximately 20 channels need less than 30 minutes for complete test setup and checkout.

Other major benefits obtained from the new system are the data processing speed which is considerably faster than with the old system and data is now displayed in "real time", not 2 or 3 minutes after the data scan. System security is a major improvement in S³ with various levels of entry permission granted to users based on their need to access system features. Without proper permission, it is almost impossible to access the DOS operating system or to operate the floppy disk drive; thereby almost completely eliminating the possibility of a virus entering the system. All system databases are protected to eliminate the inadvertent deletion or corruption of test data.

Another important feature is that the system maintains a continuous history of test events in an event log database as part of the permanent test data. This event log lets the system operators and test users log significant events manually and the system automatically logs all limit changes, limits exceeded and other test related information. This feature has already proven to be useful in reviewing historical events after test completion.

TESTS COMPLETED WITH S³ TO DATE

To date over 180 tests have been completed using S³ for data acquisition. These tests have ranged in size from small tests with only 4 thermocouples to large spacecraft subsystem tests with more than 200 channels of data. Numerous tests have been performed on *Wide Field/Planetary Camera II* hardware in preparation for the replacement of the original camera in the *Hubble Space Telescope*. Other space flight programs which have been supported with data acquisition during thermal vacuum tests are: *Mars Observer*, *Topex*, *Lambda Point Experiment*, *MSTI*, *NSCAT*, *Galileo* and the *CRAF/Cassini* projects.

PLANS FOR THE FUTURE

Because of the success of the S³ data acquisition system and the fact that the system is meeting and/or exceeding all of our operational requirements, no plans exist at present, for any major changes to the software or hardware.

Upgrades and new releases to the various software components will be installed only when it can be shown that the upgrade will significantly improve the performance of the system. Both *Fox Software* and *Novell* plan to release major software updates in the near future and these updates will be evaluated prior to installation into the system.

CONCLUSION

The personal computer based data acquisition system which was designed and built by JPL has met or exceeded all of the requirements for the intended application of acquiring, recording and processing thermal-vacuum test data.

The success of the system design can be attributed to careful up-front planning, development of specific detailed requirements, the implementation of design ideas from a broad range of users, developers and system operators and the attention to detail by the software development engineering staff during both the system design phase and the software coding phase.

The hardware has proven to be very reliable and the use of commercial off-the-shelf software packages and a fault tolerant networking system has also contributed to system reliability.

Finally, the simplicity of operations and the easy to comprehend graphic user interface has provided a significant cost savings in both user training and test setup times.