

11-31

NASA Technical Memorandum 107701

(NASA-TM-107701) SPACE STATION
FREEDOM TECHNOLOGY PAYLOAD USER
OPERATIONS FACILITY CONCEPT (NASA)
14 p

N93-16373

P.14

Unclas

G3/81 0139893

Space Station Freedom Technology Payload User Operations Facility Concept

Gary N. Henning
Lockheed Engineering and Sciences Company
Hampton, Virginia

Don E. Avery
NASA Langley Research Center
Hampton, Virginia

December 1992

National Aeronautics and
Space Administration

Langley Research Center
Hampton, Virginia 23665-5225



Space Station Freedom Technology Payload User Operations Facility Concept

Gary N. Henning
Lockheed Engineering and Sciences Company
Hampton, Virginia

Don E. Avery
NASA Langley Research Center
Hampton, Virginia

Abstract

This report presents a concept for a User Operations Facility (UOF) for payloads sponsored by the NASA Office of Aeronautics and Space Technology (OAST). The UOF can be located at any OAST sponsored center; however, for planning purposes, it is assumed that the center will be located at Langley Research Center (LaRC).

Introduction

Payload operations on Space Station Freedom will be supported on the ground by the Huntsville Operations Support Center (HOSC) at Marshall Space Flight Center (MSFC). This responsibility includes support for the International Partners as well as NASA users. The responsibility encompasses operations planning, on-orbit operations, real-time replanning, and post mission review.

The HOSC will also include an operations facility to accommodate Principle Investigators (PIs) who wish to view their data and conduct command and control during their experiment. However, this may result in long stay times in Huntsville, Alabama, that will be difficult and costly for the PIs. Because of this and a need for operations continuity, the HOSC is encouraging the NASA user community to support experiments from remote User Operations Facilities (UOF) and utilize the nationwide communications network for data distribution and operations support. In response, the OAST has

developed a concept that will provide services apropos for technology payloads. The facility could be located at any OAST sponsored center; however, for planning purposes it is assumed that the center will be located at LaRC.

Purpose

The conceptual design of an OAST UOF that resulted from two meetings with MSFC/Mission Operations Lab personnel is presented in figures 1 thru 8. The purpose of this paper is to document the meeting results and the associated discussions both for the visibility of HOSC personnel and for review by the OAST user community.

Design Drivers

For most technology payloads, the data gathered might be characterized as data that can be analyzed to understand how something acts or how something works. This provides the following design drivers:

1. Payload data must be delivered to the PIs in a timely manner and in a useful format.
2. Ancillary data must be sufficient to enable the analyst to identify and eliminate false results.
3. Archival data must be stored to support future research.

With a few exceptions Technology payloads will not require that data be observed in real-time (seconds). However, to allow rescheduling or replanning in response to data quality or unexpected results, the payloads will need to receive data in near-real time (up to 1-day). Distributing data in near-real-time rather than real-time enables two design drivers:

4. Around-the-clock operations to support technology payloads is not a requirement.
5. Payloads that require real-time data can be supported by exception at the US Operations Center (USOC located at MSFC), or at the UOF located at LaRC, or if the data window is short term, by NASCOM transmission to the PI at a remote site.

A requirement for the UOF to provide experiment analysis for an individual payload has not been identified. This enables the following two drivers:

6. Analysis services by the UOF can be limited to evaluation of communication system quality and the payload environment on-board.
7. The UOF will participate in problem analysis (and solution) on a "System" level and depend upon the payload for analysis of payload performance.

Discussion of UOF Concept

Figures 1 through 8 present a concept for a UOF to support technology payloads sponsored by OAST. The figures have been discussed with MSFC personnel. The concept characterizes a UOF which is an extension of the HOSC at MSFC and thereby facilitates plans by the Program to support payloads.

The first figure shows the path of mission planning data and mission operations data to the UOF. Payload data and video (and ancillary data) from the SSF will be down linked by way of the TDRSS Ku band and received at both the HOSC at MSFC and the SSCC at JSC. The UOF will receive operations data via the HOSC and video via the SSCC. The HOSC will also host a database for all user related mission planning. In summary, the HOSC and the SSCC will act as the operations interface between the SSF Program and the users (Payloads). This plan has been incorporated into the concept presented herein without any exceptions. Also, since the data will be delivered from the SSF unaltered, even encrypted data, if needed, will not present an issue.

Figure 2 illustrates how the UOF will work with the Payload Operations Integration Center (POIC). The POIC is a facility within the HOSC which will be the management and information center for mission planning and mission operations. To plan the mission, to change mission plans, or to support activities on-board the SSF, the UOF will work directly with the POIC.

Mission planning will include mission development activities such as payload initialization procedures, payload operations procedures,

crew procedures, and simulation exercises. The UOF will also develop changes during the mission with the POIC. Such changes may include new uplink commands, revised schedules or procedures or changes to on-board software. Changes which must be transmitted to the SSF will be planned with the POIC and transferred to the SSCC for uplink, as shown in the figure, via the TDRSS S-band.

Similar to the presentation in figure 1, figure 2 describes the operations interface between the SSF Program and the user. This plan has been incorporated into the concept presented herein without any exceptions.

Figure 3 completes the effort to characterize the operations interface between SSF Program and the user community. The Program will provide one user facility, the United States Operations Center (USOC), at the HOSC for PIs who wish to support a mission from MSFC. For all other users the SSF Program perimeter is the delivery of data to the users as depicted by the gray area in the figure. The user may be a UOF as described herein, or it may be a remote terminal at a PI location (direct communication not shown), or it may be a communication Gateway which is the interface with an international partner. An issue, which will be clarified below, is whether the HOSC has the responsibility to deliver data to the communications network or to the UOF. The difference is the cost of the communications medium (lines).

Figure 4 shows the concept for a UOF that resulted from discussions with MSFC operations personnel. The UOF facility includes a network interface, a workstation, a file server and database, a terminal for visiting PIs, and a terminal to handle off-line services. The network interface will receive transmissions from MSFC over a T-1 line, and direct the data to the UOF facility. The capability of the T-1 line is 1.55 Megabit/sec. The workstation will be set up to manage data throughput and support UOF services. The workstation will be the primary terminal for housekeeping and for coordination with the HOSC. The file server will provide short-term and archival storage and be the source for retransmission of data to PI terminals, both local and remote.

A terminal will be available for PIs who wish to support a mission from the UOF. This will be particularly beneficial for payloads which require ground support during the execution of an experiment by the crew. The PI will be able to view data as it is received and be able to

respond to questions as they occur. The service desk will have a terminal to respond to questions from remote PIs and to work with remote PIs when problems or changes require attention.

PIs will access stored data either directly from the HOSC or from the UOF. It is expected that the need for real-time data will be the exception and that normal data needs will be satisfied from data storage. The HOSC will provide short term storage, the UOF will provide short-term and long term storage.

Figure 5 shows how the facility in Figure 4 will be implemented. The UOF provides a service to the SSF Program as an interface between the HOSC and the individual payload PIs. In this context the UOF is an extension of the HOSC with similar functions as the USOC, i.e., to accommodate users. Indeed, operationally, the UOF and the USOC are very similar. This was recognized early in the conceptual design effort and was a useful parameter in the development of a UOF for technology payloads.

A T-1 line to LaRC that can be available for SSF mission support is not available at this time. This will be a leased line. Whether this line will be provided by the Program or by the UOF has been identified as an issue. The network interface will utilize the NASA network at LaRC with addition of equipment as necessary (an additional deblocker). The workstation will be a copy of the user workstation designed for the USOC. By copying the USOC workstation, the UOF realizes a secondary benefit, i.e., much of the software that is designed for the USOC will be applicable for the UOF also. In addition, MSFC has offered design support to implement the workstation. Data files for short-term and long-term storage will be implemented to the extent possible in database equipment available at LaRC.

The size of the UOF facility is estimated for the following accommodations: a workstation, two desk top terminals for PIs, a services desk and terminal, a storage system to archive data, and a conference table with chairs, conference phone and vuegraph projector. The UOF is not a large facility, perhaps the space equivalent of about three offices.

Figure 6 is included to show one option of how the UOF may be managed. The figure shows OAST Sponsor functions in four categories; direct support to the Payloads, interface activities to

coordinate the Payload and the Program, activities which qualify the payload for flight, and activities which prepare for operations. Because the sponsor is an "Unofficial" function, these activities support the Payload as a friend rather than as a representative of the Program. It is in this context that a UOF is proposed which can provide services for OAST payloads. Personnel will supply skills to (1) operate the facility, (2) provide mission interface services for the payloads, and (3) support the planning, reconfiguration and mission readiness functions. Figure 6 is intended to illustrate that the UOF can be managed in such a manner that its charter will be continually justified by services provided.

Figure 7 & 8 are the short-term schedule and long-term milestones. The short-term schedule is tentative because of review of the Program schedule for the HOSC. The long-term milestones support the goal of an operational UOF in 1997.

Issues and Recommendations:

Issue 1: The key issue before all others is whether to provide a UOF for technology payloads. Certainly it is not unreasonable for PIs to retrieve data from the USOC and it may not be unacceptable for a PI to travel to the USOC when real-time support is needed. It may be more difficult to respond to experiment problems from a remote location if HOSC personnel are barely familiar with the payload and the PI. And considerable lost time and expense may result if the PI isn't familiar with the HOSC process for initiating and verifying changes during a mission. Similarly, a new group of PIs will work with the HOSC to plan operations for each mission, thus, it may require considerable expense for the HOSC to train the new PIs in the flight readiness process.

Recommendation: The advantages of having skilled personnel to help the PIs through the operations process, along with the desire to have a data archive for future research, plus the need to encourage technology research in space and "make it easy", are offered as justification for a UOF for technology payloads. It is recommended, therefore, that the development of a UOF be continued.

Issue 2: An archive of data collected by technology payloads in space should be managed as a national resource. The archive should be cataloged to enable future investigators to research an experiment

for particular information and should include sufficient ancillary data to enable a thorough understanding of experiment conditions. The archive system should be useful to the technology community to avoid the need to recreate an experiment again.

Recommendation: Develop an archive system at the UOF to ensure accessibility and usefulness of SSF technology experiment data.

Issue 3: Two design drivers (4&5) for the UOF concept are that the technology payloads will not require around-the-clock support and those payloads that do require on-line, real time support can be handled as exceptions. An issue which results is how the UOF can be operated on a normal workday schedule and coordinate operations with the HOSC which will be operated around-the-clock.

Recommendation: Plan for the UOF to support operations on an eight hour workday schedule. Identify impacts related to onboard scheduling and overtime support required by technology payload experiments.

Issue 4: Payloads will supply operations requirements in the Payload Integration Agreement (PIA) and operations data in the PIA Annexes. MSFC Operations personnel are expecting to perform initial mission planning on the basis of these documents without payload involvement. If Program personnel can perform this initial planning without involving the payloads it will realize a considerable cost savings to the payloads. The issue is the level of involvement of UOF (or OAST) necessary to effectively implement this system.

Recommendation: Continue to participate in the development of the PIA and PIA Annexes blank books to assure that the information supplied by the payloads will enable the Program to plan payload operations.

Issue 5: The program has chosen to interpret the communications perimeter as the input to the data distribution network. Thus, the Program has not accepted the cost of data communication to LaRC.

Recommendation: Continue to press for the SSF Program to deliver payload operations data to the UOFs and bear the cost of data transmission (a T-1 data line to LaRC).

Issue 6: An effort is underway by MSFC operations personnel to identify ancillary data needed by the payload community. This data will be distributed as a communications packet. An issue for the UOF is identification and storage of ancillary data that is necessary to support analysis of payload data.

Recommendation: Analyze this issue with the viewpoint that ancillary data that is necessary for the analysis of experiment results is payload data and will be related and archived as payload data.

Concluding Remarks

1. The UOF facility presented herein will provide services appropriate for technology payloads. It will facilitate planning and support PIs during experiments on-board the SSF. An effort to develop the design of a UOF for technology payloads is felt to be worthwhile.

2. The cost of a facility which reflects the concept presented will take advantage of several factors:

The network interface will add a few equipment items to the local network at LaRC.

The cost of a T-1 line is an issue.

The workstation can be the same as the workstation being designed for the USOC.

The software for the workstation can copy the software being designed for the USOC.

The UOF may be able to piggy-back data storage and data archives on equipment available at LaRC.

The UOF can be managed as an additional OAST function.

The UOF personnel can be selected for skills needed.

If the design of the UOF takes advantage of these factors, then the cost of a UOF for technology payloads will indeed be modest. With that in mind it is worthwhile to continue to pursue a UOF design within the guidelines and schedules of the concept presented herein.

FIGURE 1 - DATA DELIVERY TO UOF

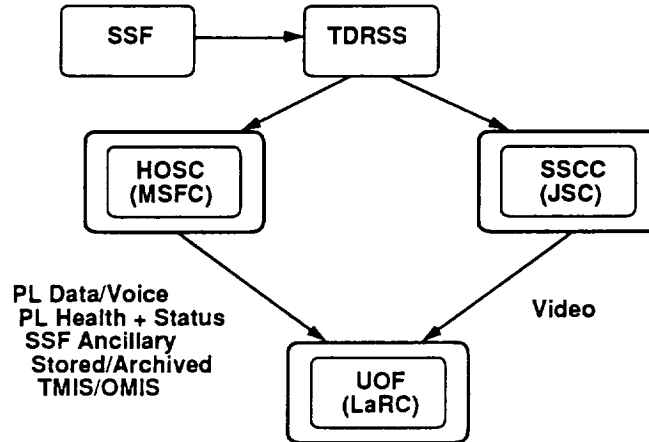

Draft, Gary Henning, June 92, LaRC SSFO

FIGURE 2 - MISSION PLANNING & COORDINATION

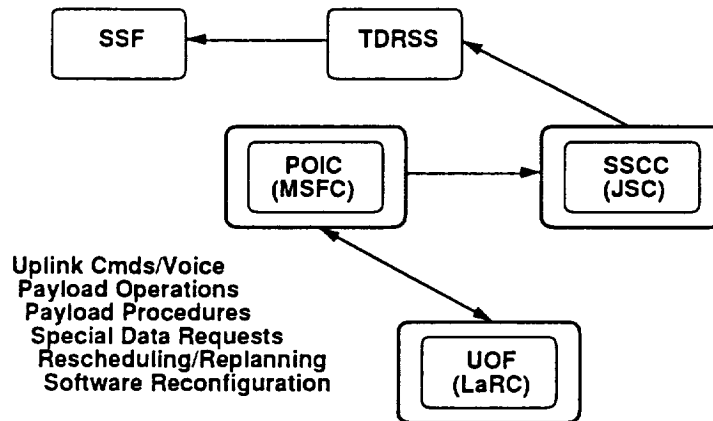

UOI-FCD - 4.1.6 - "The POIC supports all PL operations whether performed by the flight crew or by UOF personnel."

Draft, Gary Henning, June 92, LaRC SSFO

FIGURE 3 - SSFP PERIMETER OF RESPONSIBILITY

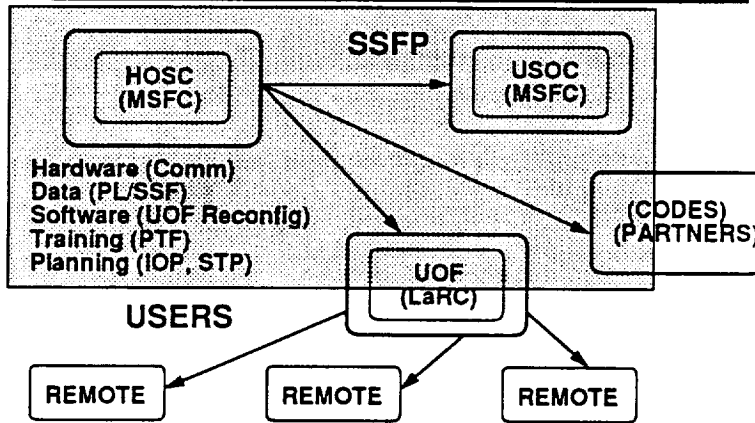

UOI-FCD Draft - 5.1.2 - "Code O shall develop and maintain the Comm capabilities between the POIC and U.S. user operations facilities, necessary to support PL operations - - - and the comm capabilities required to support mission planning."

Draft, Gary Henning, June 92, LaRC SSFO

DEAVERY 22/91

FIGURE 4 - DATA DISTRIBUTION - OVERVIEW

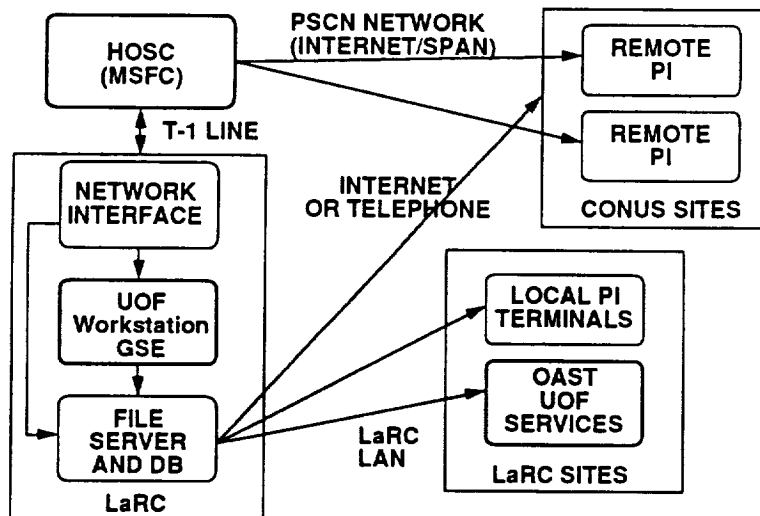

Draft, Gary Henning, June 92

LaRC SSFO

FIGURE 5 - FACILITY IMPLEMENTATION

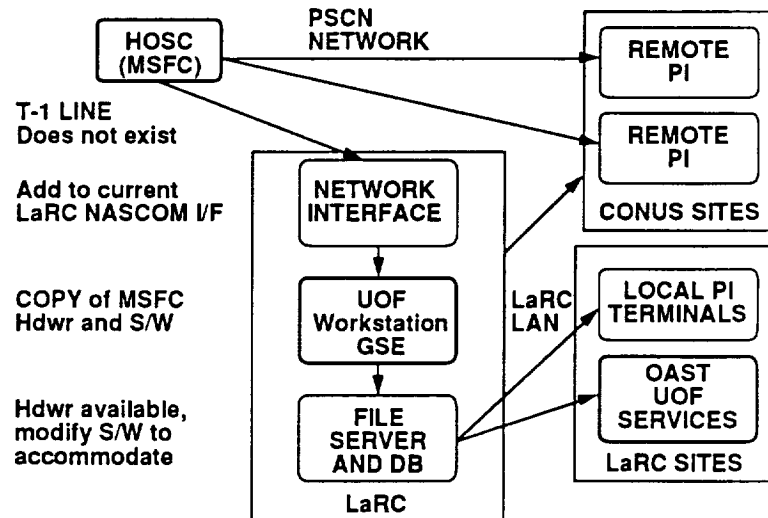

Draft, Gary Henning, June 92 LaRC SSFO

FIGURE 6 - OAST SPONSOR - SCOPE

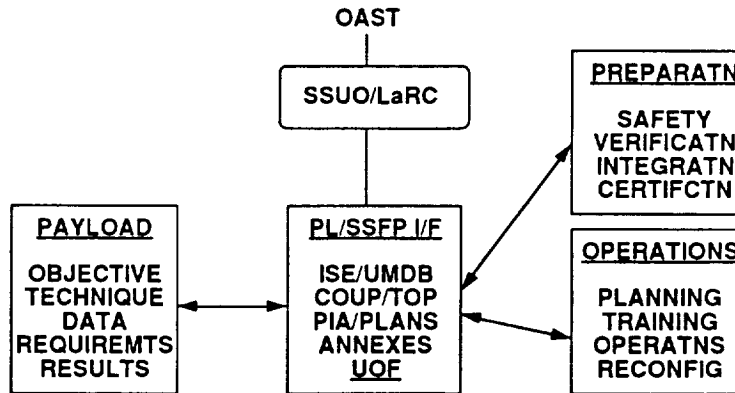

A UOF which is adequate to support OAST PLs can be managed as an added SSUO "Code R Sponsor" service.

Draft, Gary Henning, June 92 LaRC SSFO

FIGURE 7 - UOF CONCEPT DEVELOPMENT

FACILITY CONCEPT

- > June 30, 92 >> Initial Concept of UOF for LaRC
- > Aug 31, 92 >> Concept for Requirements on POIC
- > Oct 31, 92 >> Concept for User Data Processing
- > Mar 31, 93 >> Concept Cost Breakdown.

PROPOSAL DEVELOPMENT

- > Mar 31, 93 >> OAST UOF Mission Operations Plan
- > July 31, 93 >> OAST UOF Proposal

FIGURE 8 - UOF CONCEPT DEVELOPMENT

COMMENTS:

Milestones leading to fullup operations are as follows:

- > Dec 31, 93 >> OAST Approval
- > Mar 31, 94 >> OAST UOF Funding Plan
- > Oct 1, 94 >> Long Lead Funding
- > Oct 1, 95 >> Installation and Test Funding
- > Oct 1, 96 >> Initial Ops Funding
- > Oct 1, 97 >> Full Ops Funding

ISSUES:

During initial operations in 1997 the OAST UOF will be operated redundantly to the USOC. The facility will be brought on-line independently as it is proven.