

N93-17321

1992

**NASA/ASEE SUMMER FACULTY FELLOWSHIP PROGRAM**

**MARSHALL SPACE FLIGHT CENTER  
THE UNIVERSITY OF ALABAMA**

**SEDS1 MISSION SOFTWARE VERIFICATION  
USING A SIGNAL SIMULATOR**

**Prepared By:** William E. Pierson

**Academic Rank:** Professor

**Institution:** West Virginia Institute of Technology  
Department of Electrical Engineering

**NASA/MSFC:**

**Laboratory:** Program Development  
**Division:** Payload and Orbital Systems  
**Branch:** Orbital Support Systems Group

**MSFC Colleague:** Charles Rupp



# SEDS1 MISSION SOFTWARE VERIFICATION USING A SIGNAL SIMULATOR

July, 1992

## BACKGROUND

The first flight of the Small Expendable Deployer System (SEDS1) is scheduled to fly as the secondary payload of a Delta II in March, 1993. The objective of the SEDS1 mission is to collect data to validate the concept of tethered satellite systems and to verify computer simulations used to predict their behavior. SEDS1 will deploy a 50 lb. instrumented satellite as an end mass using a 20 km tether. Langley Research Center is providing the end mass instrumentation, while the Marshall Space Flight Center is designing and building the deployer. The objective of the experiment is to test the SEDS design concept by demonstrating that the system will satisfactorily deploy the full 20 km tether without stopping prematurely, come to a smooth stop on the application of a brake, and cut the tether at the proper time after it swings to the local vertical. Also, SEDS1 will collect data which will be used to test the accuracy of tether dynamics models used to simulate this type of deployment. The experiment will last about 1.5 hours and complete approximately 1.5 orbits.

Radar tracking of the Delta II and end mass is planned. In addition, the SEDS1 on-board computer will continuously record, store, and transmit mission data over the Delta II S-Band telemetry system. The Data System will count tether windings as the tether unwinds, log the times of each turn and other mission events, monitor tether tension, and record the temperature of system components. A summary of the measurements taken during the SEDS1 shown in Table 1. The Data System will also control the tether brake and cutter mechanisms.

Preliminary versions of two major sections of the flight software, the data telemetry modules and the data collection modules, were developed and tested under the 1990 NASA/ASEE Summer Faculty Fellowship Program. To facilitate the debugging of these software modules, a prototype SEDS Data System was programmed to simulate turn count signals. During the 1991 summer program, the concept of simulating signals produced by the SEDS electronics systems and circuits was expanded and more precisely defined. During the 1992 summer program, the SEDS signal simulator was programmed to test the requirements of the SEDS Mission software, and this simulator will be used in the formal verification of the SEDS Mission Software. The formal test procedures specification was written which incorporates the use of the signal simulator to test the SEDS Mission Software and which incorporates procedures for testing the other major component of the SEDS software, the Monitor Software.

## SEDS MISSION SOFTWARE VERIFICATION TEST SPECIFICATION

A series of tests will be performed to exercise the software modules which make up the Mission Software of the SEDS Data System. These tests will be performed by using a SEDS Signal Simulator to generate signals which will simulate the inputs normally produced by sensors and circuits in the SEDS system. The test configuration is depicted in Figure 1. A SEDS Data System CPU Card will be modified to construct the SEDS Signal Simulator.

Signals will be generated which simulate both nominal flight conditions and all anticipated anomalies. In addition, the tests provide a means for monitoring and analyzing outputs produced by the SEDS Mission Software for controlling the tether brake and cutter mechanisms.

**Table 1. SEDS Measurements**

<u>MEASUREMENT</u>	<u>RANGE</u>	<u>SAMPLE RATE</u>
T1 - Tether Temperature	-30 <sup>0</sup> to +80 <sup>0</sup> F	1 per 10 seconds
T2 - Brake Temperature	-30 <sup>0</sup> to +80 <sup>0</sup> F	1 per 10 seconds
T3 - Canister Temperature	-30 <sup>0</sup> to +80 <sup>0</sup> F	1 per 10 seconds
T4 - Electronics Temperature	-30 <sup>0</sup> to +80 <sup>0</sup> F	1 per 10 seconds
B1 - Turn Counter Beam #1	Discrete	Asynchronous
B2 - Turn Counter Beam #2	Discrete	Asynchronous
B3 - Turn Counter Beam #3	Discrete	Asynchronous
F1 - Tether Tension #1	-0.25 to +0.25 N.	500 per second
F2 - Tether Tension #2	-2.5 to +7.5 N.	500 per second
IN1/IN2- Satellite Deployment	Discrete	Asynchronous

**FIGURE 1. SEDS MISSION SOFTWARE TESTING USING A SIGNAL SIMULATOR**

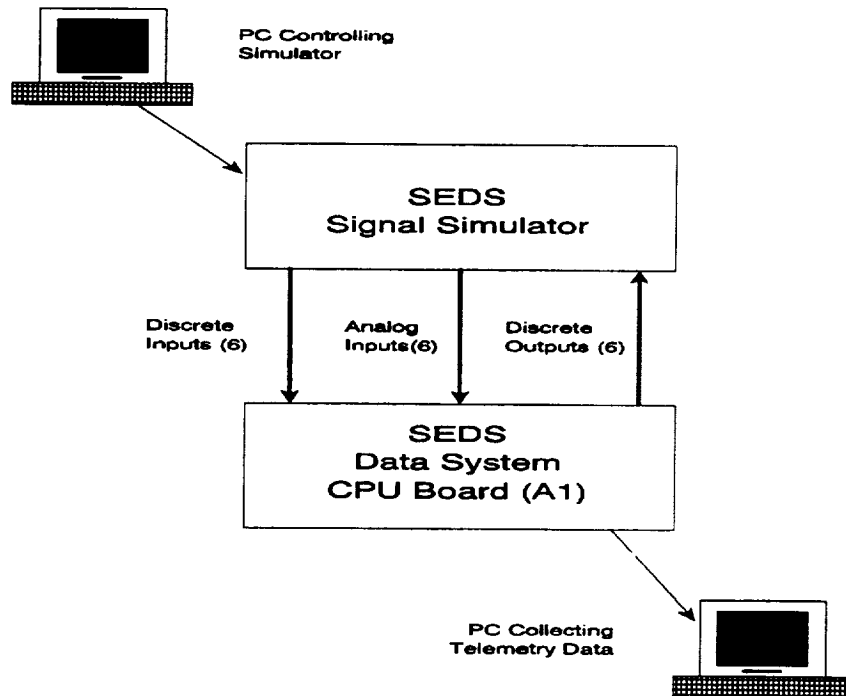

With the exception of control signals for the tether brake and cutter, correct operation of the Mission Software can be verified by examining the telemetry data collected and transmitted by the Mission Software over the serial port of the SEDS Data System. An IBM-compatible PC will be

connected to this serial port to collect the mission data. The PC will execute software to display summary data contained in the Master Frames sent by the SEDS Data System. In addition, this software will store the serial data in a disk file to be used in post-test analysis and documentation. The signals generated by the SEDS Data System to control the tether brake and the tether cutter cannot be analyzed by monitoring the serial data stream. Therefore, the PC controlling the SEDS Signal Simulator will monitor, display and store these control signals levels. Specifically, the brake motor and tether cutter signals are sampled once every 1ms and their state is displayed by the PC anytime a change is detected in any one of the signals. The time that the change was detected is also displayed.

Three tests are performed on the SEDS Mission Software using simulated input signals. The first test generates turn count signals at three different rates: fast, nominal, and slow. In addition, signals are generated which simulate false signals which may occur during flight due to vibration of the tether. and which are eliminated by the Mission Software. No turn count failures are introduced during this first test.

The second test simulates a failure on turn count channel-B by intermittently turning signals off and on. A total of 50,000 simulated turn counts are generated on channel-A to verify that the SEDS Mission Software can withstand a failure on channel-B. The third test is similar to test #2 except that a failure is introduced on channel-A.

During each of the SEDS Mission Simulation Tests, the SEDS Simulator will generate independent signals to each analog input of the SEDS unit under test. The analog signals provided by the simulator will be one of three levels: 0v (0.2v, max), half-scale ( $2.5v \pm 10\%$ ), or full-scale ( $5.0v \pm 10\%$ ) and will be applied in regular cycles. The purpose of applying simulated analog inputs to the SEDS Data System is not to gauge the accuracy of the A/D converter circuitry but to assure that the data collection modules in the Mission Software is correctly collecting and transmitting temperature and tension information.

## CONCLUSION

The SEDS Signal Simulator will be used in the formal verification of the SEDS1 Mission Software. The Simulator will not only emulate normal flight conditions but also exercise all modules written to handle anticipated anomalous flight conditions, conditions that would be difficult to reproduce and control with actual SEDS hardware. The simulator will apply signals which test the limits of the SEDS Mission Software as defined in the requirements document, thereby increasing the confidence that the Mission Software will perform according to specifications during the actual flight of the SEDS experiment. With little modification, the Simulator can be useful in the software development of future SEDS flights.

## REFERENCES

1. "SEDS Data System Functional Requirements", Energy Sciences Laboratories, Inc. and Program Development, MSFC, May 1988.
2. "SEDS Data System Data Collection and Telemetry Software", Final Report, NASA/ASEE 1990 Summer Faculty Fellowship Program, Contract No. NGT-01-002-099, MSFC, Huntsville, AL.
3. "SEDS Mission Software Verification Test Procedures, NASA/ASEE 1991 Summer Faculty Fellowship Program, Contract No. NGT-01-008-021, MSFC, Huntsville, AL.
4. "MSFC Software Management and Development Requirements Manual", Software and Data Management Division, January 1991, MSFC, Huntsville, AL.
5. "SEDS Software Requirements Document (DM06), Vol. II., MSFC-RQMT-1967, February 1992, MSFC, Huntsville, AL.
6. "SEDS Software Verification Test Specification (DM20), MSFC-SPEC-2033, July 1992, MSFC, Huntsville, AL.

