

177070
NASW-4435 P17

FINAL REPORT

THE DESIGN OF A LONG RANGE MEGATRANSPORT AIRCRAFT

**Purdue University
School of Aeronautics and Astronautics
West Lafayette, Indiana**

Professor Terrence A. Weisshaar

June 30, 1992

(NASA-CR-192077) THE DESIGN OF A
LONG RANGE MEGATRANSPORT AIRCRAFT
Final Report, Aug. 1991 - Jun. 1992
(Purdue Univ.) 17 p

N93-17711

Unclas

G3/05 0141690

Table of contents

Executive summary and impact statement..... 1
Technical report 2
Appendix..... 12

Class syllabus - Spring 1992

Carl Allen - AIAA Student Paper

Executive Summary and Impact Statement

This final activity report covers the period from August 1991-June 1992. During this time two design classes at Purdue University participated in the design of a long range, high capacity transport aircraft, dubbed the megatransport. This design effort involved 73 students organized into 13 teams. Five teams participated during the Fall Semester while seven teams participated during the Spring semester. In addition, during this period, the School of Aeronautics continued to modify its classroom program in design, acquire resources (dedicated Sun Workstation terminals paid for by the University) and meet with and correspond with leading design educators in the United States and throughout the world.

During both semesters, guest speakers presented information to students, provided critiques on student efforts and advised their efforts. These outside participants included Mr. John Roncz, designer of the Voyager Aircraft that flew around the world unrefueled. In addition, Mr. Bud Nelson, President of Nelson Aviation in Kent, Washington, presented details of preliminary design for aircraft. Mr. Nelson is a noted designer of sport aviation aircraft and has years of actual design experience.

This year also saw the continuation of Thiokol Corporation's sponsorship of our design technical writing competition. Thiokol provided a one day seminar in September on technical writing and oral presentation skills. The materials used in this technical seminar were used during the Spring semester by the Professor Weisshaar and now constitute a major resource for future classes. Thiokol representatives also reviewed team technical reports and provided prize money and certificates for the first place teams from Fall and Spring semesters.

Mr. Carl Allen, the Graduate Teaching Assistant for the design course, researched and wrote a technical paper entitled "A Straightforward Method of Minimizing the Induced Drag of Arbitrary Airplane Configurations." He participated in the AIAA Midwest Regional Student Conference, held in Columbus, Ohio in April 1992. This paper placed second in the competition.

Future efforts will involve examination of the suitability of using TQM procedures in the class and strengthening the emphasis on team relations and decisionmaking. We are currently actively recruiting a new faculty member whose responsibility at the undergraduate level will be to teach design.

THE DESIGN OF A LONG RANGE MEGATRANSPORT AIRCRAFT

Purdue University
School of Aeronautics and Astronautics
West Lafayette, Indiana

Professor Terrence A. Weisshaar
Carl L. Allen, Graduate Teaching Assistant

Abstract

Aircraft manufacturers are examining the market and feasibility of long range passenger aircraft carrying more than 600 passengers. These aircraft would carry travelers at reduced cost and, at the same time, reduce congestion around major airports. The design of a large, long range transport involves broad issues such as: the integration of airport terminal facilities; passenger loading and unloading; trade-offs between aircraft size and the cost to reconfigure these existing facilities; and, defeating the "square-cube" law. Thirteen Purdue design teams generated RFP's that defined passenger capability and range, based upon team perception of market needs and infrastructure constraints. Turbofan engines were designed by each group to power these aircraft. This paper will review the design problem and the variety of solutions developed.

Introduction

During 1991 the operating losses of major airlines exceeded the total profits earned since the introduction of jet transportation in the 1950's. Despite this disaster and the worldwide economic recession, the demand for air travel is predicted to resume its growth within the next few years. This growth will be accelerated as the world becomes more economically and politically dependent.

The number of airline revenue passenger miles (RPM) is predicted to more than double by the year 2010. Boeing predicts that the number of available seat miles (ASM) will increase by more than 180 percent to meet air travel demands in the year 2010.¹

The increased air travel demand will be an opportunity for airlines to increase revenues and an opportunity for airframe manufacturers to sell airplanes. On the other hand, increased traffic may also place a burden on airports around the world, many of which are at or near traffic saturation levels.

To take advantage of increased traffic, while recognizing airport congestion difficulties, airlines are considering new airplanes with more than 150% the capacity of the Boeing

747-400. Predictions for the number of new large transports needed by 2010 range as high as 550 units.²

The new large capacity airliners have been referred to as "super-jumbos", "megatransports" or "megajets." We will use the term "megatransport" because it conjures up visions of large size and weights. The term "mega" refers to the projected take-off gross weight (TOGW) of these aircraft, a number expected to exceed 1,000,000 lbs.

The megatransport efficiency will place them in competition with existing Boeing 747 designs, the proposed MD-12 and possible new SST's being proposed for long range use. Although both competitors have smaller seating capacities, the SST is faster and as productive, while the subsonic 747 models are proven items.

This paper reviews the design challenge, its objectives and its constraints, and summarizes some of the solutions developed by student design teams. It begins with a discussion of the market needs and the economic risks involved in such a project. It then summarizes some of the different approaches taken to solve the problem and the difficulties faced by the design teams. Finally, some "lessons learned" are discussed at the end of the paper.

Design Problem - Markets, Needs, Constraints

Design addresses a customer need and proposes a solution. The consideration of need requires an answer to the question "Where are the markets for large capacity, megatransport airliners?" The answer to this question will determine the minimum range of the new aircraft.

Markets

First of all, domestic markets were considered, but these markets concentrate on frequent service and have nowhere near the number of passengers per flight to justify a large capacity aircraft. If a plane with large capacity is operated at low passenger load factors then economic disaster for the airline is certain.

Overseas markets with high demand but only a few flights a day appear to have the most potential for generating revenue. The fastest growing markets for North America appear to be in the Pacific Rim region. The economic growth there indicates that this trend will continue.

Table 1 shows a prediction of the ASM categories by routes for U.S., European, and Asian airlines.¹

The design teams found that most attractive city pairs could be serviced with an aircraft whose range was 7000 nautical miles (New York/Hong Kong). The fuel fraction (ratio of fuel weight to take-off gross weight) for long

Table 1. Percentage of total Available Seat Miles by airlines to and from three regions (1991 value / 2010 forecast)

Travel to/by	US Airlines	European	Asian
North America	61% / 56%	32% / 26%	28% / 28%
Europe	21% / 20%	40% / 36%	17% / 28%
Asia-Pacific	12% / 20%	12% / 27%	47% / 41%

flights is very large, even if the aerodynamic efficiency is high and the engine thrust specific fuel consumption (TSFC) is low.

Airlines are known to favor buying aircraft with range equal to the B-747. On the other hand, the design teams felt that extreme range was an expensive objective. As a result they focused on high passenger loads at the expense of extreme range. Even then, the aircraft TOGW is in the 1,000,000 lb. weight class compared to the B-747 aircraft with 850,000 lb. at take-off.

Special problems - technology and terminals

The long range markets with high passenger demand are currently served by B-747, DC-10 and MD-11 aircraft. Boeing 747 class airplanes are very large. They are not only the competition for the megatransport, but they are the standard for designing terminal facilities and runways. Further increased size might require modifications to runway thicknesses and widths, taxiways and terminal facilities. The primary considerations are:

- **landing gear design** to prevent damage to the concrete runways and provide capability to fit on runways
- **airport gates and runways** built to accommodate wingspans less than 220-240 feet constrain the span of the megatransport wings
- **logistics of quickly loading or unloading** as many as 700 passengers. This includes terminals and emergency conditions.

Changes in the existing infrastructure would be costly and something the airlines cannot afford. If one accepts the infrastructure as a constraint, the design of a megatransport aircraft requires consideration of design drivers not normally considered in conventional aircraft design. In addition, this design effort requires careful use of the data base generated for smaller aircraft.

The large size of a transport with passenger capability exceeding the B-747 also places demands on technology, including structures, manufacturing, landing gear and passenger configuration, to name a few items.³

Unique megatransport design issues

There are other design issues related to the size of this aircraft. These issues provide a challenge and may be summarized as follows:

- **Defeating the "square-cube law"** The so-called Square-cube Law states that, for similar structures of different scale, the load - assumed to be proportional to weight, increases as the cube of linear dimensions, while the cross-sectional areas that resist the load increase as the square of the linear dimension. As a result, the stress increases as the linear dimension. For instance, doubling size doubles the weight.⁴

This law says that if structural loads depend upon vehicle weight then the load increases with the volume (cube of the scale dimension) of the object while the load carrying area increases as the square of the scale dimension. As a result, the stress increases with the scale of the object.

If we simply double the size of an object then the stresses double. Eventually there is a physical limit to size for which no material can be found. The square-cube law has been held in check by finding new materials, increasing the wing loading of aircraft and reducing the density of airplanes. In addition, the weight of some items on an aircraft are not functions of scale.

- **Fuselage design (People packaging).** Containment of passengers on a large transport requires less wetted area per unit volume. Safety and comfort require consideration of single and multiple deck configurations. Fuselage design is challenging because of aircraft maximum length constraints imposed by terminal facilities and the requirements for aerodynamic efficiency of the fuselage shape.

The passenger "packaging requirement" motivated team consideration of unconventional fuselage designs such as elliptical cross sections, double deck fuselages, and even dual fuselages.

- **Wing design.** The use of existing terminal facilities will impose wingspan constraints. This constraint

was addressed by using folding wing tips and multiple lifting surfaces, including tandem wings, canard configurations and three surface configurations.

The reader will note that the terminal and infrastructure requirements were treated as constraints. It would be interesting to understand the penalty that these constraints place on the design. However, except for examining the effect of wing span on weight and efficiency, little was done by any of the teams to address this issue.

□ Extrapolating empirical relations generated on the basis of smaller aircraft. The data base for preliminary design consists of design data from smaller aircraft. Careful use must be made of these formulas.

Engines

Large transports must have efficient propulsion units. Although newer aircraft such as the Boeing 777 are powered by twin engines, the large TOGW of the megatransport requires more than two engines. All teams chose to use four engines for power. These engines were turbofans with relatively high bypass ratios so that they could meet noise constraints and have TSFC's of about 0.5 at cruise.

The team design take-off gross weights (TOGW) for the aircraft designs range from just slightly below one-million pounds to about 1.2 million pounds. The propulsion requirements for the size airplane being considered are not met by an "off the shelf" engine. The engines used on the Purdue designs were designed to meet the requirements of their airplane. The cycle analysis programs ONX and OFFX, developed by Mattingly and Heiser,⁵ were used for engine design and performance predictions.

Large engines create design problems over and above the usual problems of finding an efficient design cycle. The large intakes require severe restrictions on ground clearance. This leaves the designer with a choice of lengthening the landing gear, adopting a high wing design or mounting the engines on top of the wing.

To achieve the typical take-off thrust to TOGW values of 0.30, four engines generating over 80,000 pounds of thrust each are required. Since the FAR 36 noise requirements do not account for growth above 900,000 pounds, the noise requirements for the engines will be much more restrictive than those in force now.

Inherent advantages of the megatransport

In addition to being more efficient economically, the dimensions and size of the megatransport allow for:

- more efficient use of high strength materials in the structure and more dramatic weight savings if advanced composite materials are used
- increases in aerodynamic efficiency due to the large Reynolds number at which the aircraft operates.

Cost estimation

To meet the world air traffic needs while remaining economical, the megatransport must have low operating expenses compared to existing aircraft such as the B-747 aircraft. These operating expenses translate into cost per block hour of operation and direct operating costs (DOC) given in terms of cost per available seat mile. The requirement of low DOC for a long range transport will dictate a design that is efficient in long range markets as well as for multiple medium range hops.

The estimation of direct operating costs requires an estimate of airplane cost and fuel requirements. The production costs to build the aircraft were estimated using the DAPCA IV model discussed by Raymer⁶ This model estimates cost on the basis of empty weight, production quantity, maximum airspeed and engine and avionics cost. The production quantity and schedule was set by the teams based on what the market would support, the profit margin and the estimated cost of capital.

The price of the aircraft was calculated using a cash flow analysis. This calculation considers production cost, quantity and schedule, and the cost of raising capital (interest on borrowed money) to initiate the program. The cost of capital is very important to the success or failure of a commercial venture.

Direct operating costs (DOC) were estimated using a model suggested by the Association of European Airlines. These costs were calculated, using a computer model supplied by Professor J.W. Drake⁷, as cost per block hour, where the total block time is the time required to travel from gate to gate. The input to this model includes mission data such as block time, fuel requirements, cost data for labor rates, fuel prices, engine prices aircraft purchase price, maximum weight, stage length, payload and number of crew members.

Design Resources and organization

Teams were composed of from 5 to 6 members, each with a primary responsibility. There were 5 such teams during the Fall semester and 8 teams the Spring Semester. To address this design problem in the few weeks allotted to each team was a challenge.

The design course at Purdue is one semester long. This allows about ten weeks of group effort to produce a pre-

liminary design after all the basic areas of effort are reviewed. In addition to the emphasis on technical effort, the requirements for communication in terms of writing quality and oral presentations are stressed.

During the two semesters of the academic year, the classes were presented with resources to accomplish their tasks. Resources consist of reports, papers and data obtained from the summer intern during June-August 1991. In addition, guest lecturers are invited to Purdue to share their expertise.

This year we were very fortunate to host Mr. Bud Nelson of Nelson Associates in Washington and Mr. John Roncz of Gemini Technologies. In addition, Mr. Robert Matson of the USAir Maintenance Facility in Pittsburgh lectured the class on the importance of maintainability in design.

The Thiokol Corporation developed a one day short course in technical writing and sent Mr. Alan Hanline to lecture to the Fall semester class. Thiokol also sponsored a technical writing award for the Fall and Spring semester design teams.

RFP selection and design summary

With a knowledge of the market and the effects of aircraft weight and fuel requirements on the success of various designs, the 13 Purdue design teams were free to establish their own requirements for passengers and range. On the basis of market studies and their interpretation of available data, the teams chose to design airplanes capable of carrying 650-750 passengers over ranges of 5800-7000 nautical miles.

Describing each of the 13 team designs individually and in detail is beyond the scope and purpose of this paper. Instead, a few representative aircraft have been selected for examination and highlighted in the discussion to follow.

Five of the designs generated during the two semesters will be described. Each of these designs represents a different path taken by students. The design teams produced design solutions that fell into two broad categories. These were referred to simply as "747-ish" and "different."

During the class discussions, a high premium was placed on identifying several possible solutions. Having done this, the teams were encouraged to be practical and tough in their assessment of design possibilities. They were also encouraged to take chances. So did. Some didn't.

An excellent example of the 747-like design is the Hastings 1066, shown in Figure 1. This aircraft was designed to take-off from Denver and cruise for 6830 nmi. with 740 passengers at Mach 0.87.

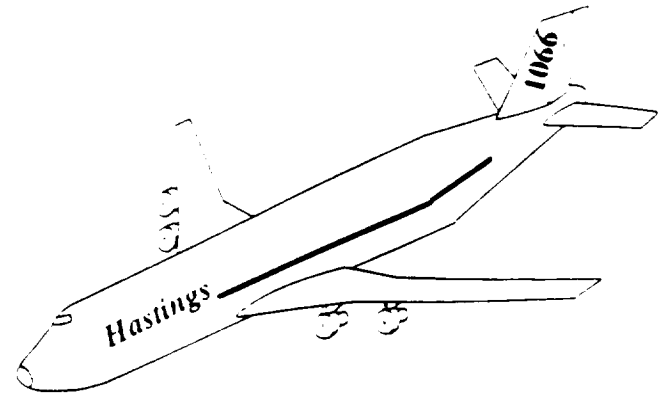
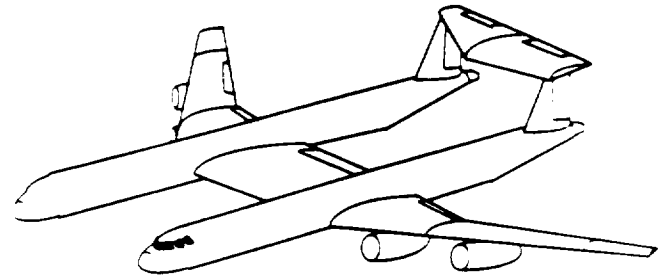

Figure 1 - Hastings 1066

An example of a different design is the WB-670, shown in Figure 2. The WB-670 airplane is a dual fuselage configuration designed to fly 6500 nautical miles with 670 passengers. The cruise Mach number is 0.87.



THE WB-670 CATAMARAN

Figure 2 - WB-670 aircraft

The dual fuselage design was chosen for two reasons. First, by using two simpler (perhaps existing) fuselages the designers believed that production costs could be reduced. Second, with the current design of airport gates, it would be more efficient to load two smaller fuselages than one large, double deck fuselage. These advantages are realized at the expense of increased wetted area and concerns for aircraft evacuation in emergencies.

The Twin 600, shown in Figure 3, was another different design. This design was generated during the Fall semester and attempted to address the issue of wingspan constraints. The Twin-600 airplane is a tandem wing configuration designed to fly 6700 nautical miles with 600 passengers at a cruise Mach number of 0.87.

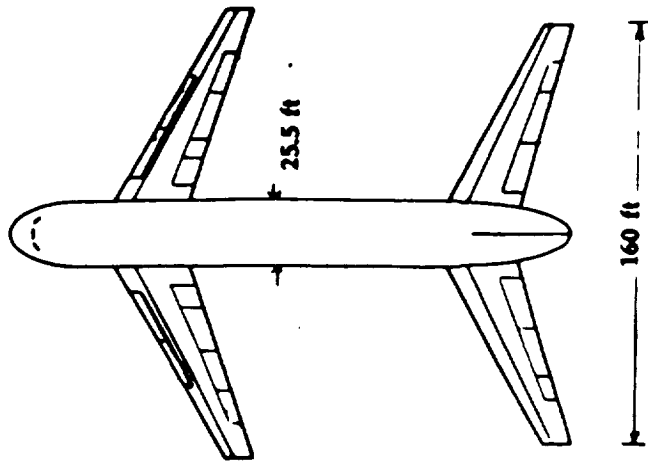

Figure 3 - The Twin 600

The tandem wing design was chosen to provide a wingspan to fit into existing airport gates without the use of folding wing tips. Folding wing tips are optional on the new Boeing 777, but no customer has selected that option. The interference between the two wings was a concern to the team, but the schedule of the class did not permit an extensive examination of this issue.

The advantages of the tandem wing go beyond airport compatibility. Since the wings are smaller, can be manufactured using proven methods. The root bending moments will be smaller, allowing a lighter wing root structure. Derivatives of this airplane are possible by inserting fuselage plugs *between* the wings.

The JM-90P took up where the Twin 600 left off. This design, shown in Figure 4, attempted to use the interference between the two lifting surfaces rather than to eliminate it. The JM-90P aircraft is a three surface configuration designed to fly 7000 nautical miles with 608 passengers at a cruise Mach number of 0.87.

The engines on the JM-90P are mounted over the wing to reduce the ground noise levels. Noise regulations are severe at many airports in the US and Europe. The limits set by FAR 36 Stage 3 do not acknowledge weight increases above 900,000 pounds.

The JM-90P design was done during the Spring semester and reflects the influence of Mr. John Roncz on the class. Mr. Roncz, the designer of the Voyager airfoils, urged the class to consider three surface airfoil solutions to the problem. The DAC-701, shown in Figure 5, was a very successful effort to use interference between the canard and the main lifting surface.

The JM-90P uses leading edge suction laminar flow control devices in addition to the use of supercritical airfoils. This is expected to increase the drag divergence Mach number and therefore allow less sweep angle. The structural weight savings in the wing is expected to be greater than the increased weight of the laminar flow control devices (including a leading edge bug shield to prevent contamination during take off and landing).

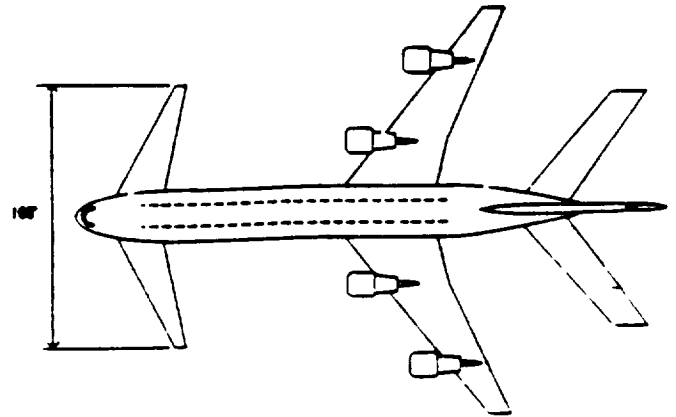

Figure 4 - JM-90P

The DAC-701 airplane, shown in Figure 5, is a three surface configuration designed to fly 7000 nautical miles, carrying 701 passengers. The cruise Mach number was chosen to be 0.85. The "high-wing" design of the canard was chosen to create wing/canard interference to provide an increased effective wingspan. This increase occurs because the biplane effect will reduce the induced drag on the main wing.

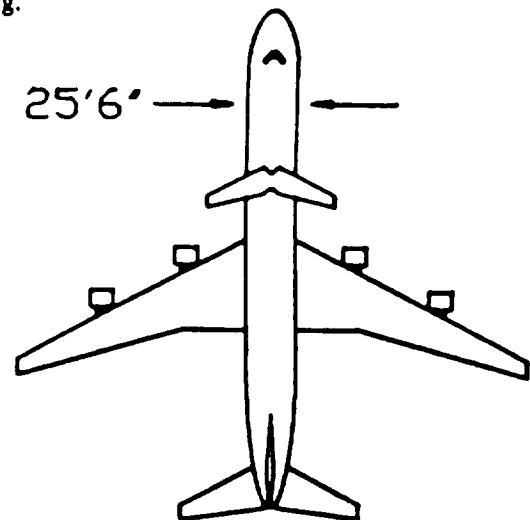

Figure 5 - the DAC-701

Finally, the LiNK-92, shown in Figure 6, represents an example of a single deck fuselage design and a three surface design. The high wing design of the Link-92 creates a problem with the carry through wing box, but is nonetheless noteworthy.

The 747-200, 300 and 400 models represent the largest passenger aircraft flying today. The Purdue designs appear to lie very close to this curve fit data. The weights used for the graph in Figure 7 were generated from component weight estimates that reflect design details such as wing geometry.

The fact that the second semester designs lie below the curve fit line in Figure 1 probably reflects a special emphasis placed on composite material use and three surface design. No one design used advanced composites extensively, but they all took special care to use composites more extensively than used at the present time.

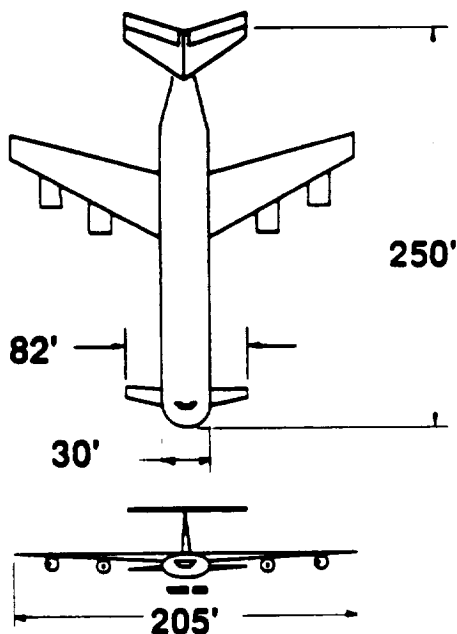

Figure 6 - The LiNK-92

Figure 7 shows operating empty weight plotted against TOGW, plotted in a log-log format. The straight line represents the curve fit for the data base chosen for this study. This data base includes medium range aircraft with large carrying capacity and long range transports such as the Boeing 747-400. Existing aircraft are shown as circles on this graph. Note that not all aircraft used for the curve-fit are shown. The aircraft TOGW are very near 1,000,000 lbs., as predicted in early studies. Note also that these designs do not have exactly the same mission. Lower TOGW is usually indicative of shorter ranges and lower passenger capacities.

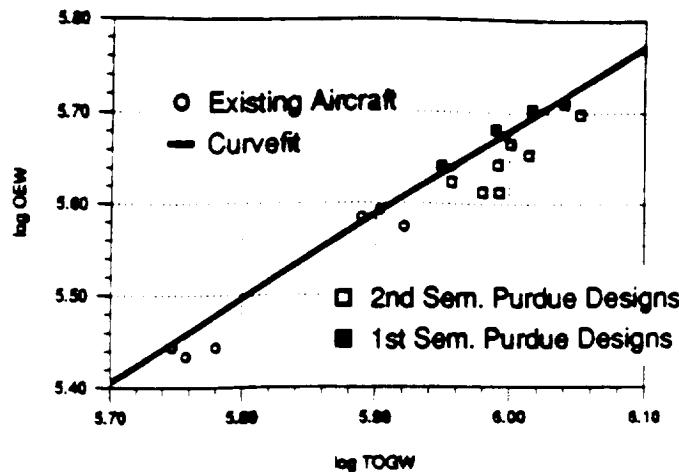

Figure 7 - OEW vs. TOGW - comparison of data base and Purdue designs

Range, payload and TOGW data for these representative configurations are presented in Table 2.

Table 2 - Range, payload and TOGW

Aircraft	range (nmi)	passengers	TOGW (lbs)
JM-90P	7000	608	1033200
LiNK-92	6000	700	904900
DAC-701	7000	701	1128700
WB-670	6500	670	976200
Twin 600	6200	600	977300

An indication of size and efficiency of each of these aircraft is provided by the data in Table 3. This table shows operating empty weight (OEW), wing span and direct operating cost per available seat mile, calculated on the basis of the ranges shown in Table 2.

Table 3 - Design OEW, wing span, DOC

Aircraft	OEW (lbs)	wing span (ft)	DOC cents/ASM
JM-90P	451200	197	2.96
LiNK-92	420800	205	2.77
DAC-701	499800	260	3.05
WB-670	480500	250	3.30
Twin 600	531200	175	2.77

Fuselage design

The heart of the design of a transport aircraft, as far as the passenger is concerned, is the fuselage. The

aerodynamic efficiency, in terms of minimizing drag, requires a slender fuselage. On the other hand, the fuselage cannot be too long so that it cannot fit in terminal areas or move unobstructed on taxiways.

One design considered by several groups was a flying wing. While aerodynamically efficient, the flying wing seats passengers in very wide rows. This makes it difficult to evacuate the aircraft in an emergency. It also makes it awkward to service the cabin in flight.

Fuselage designs finally centered on two configurations. These were the double deck configuration, such as shown in Figure 8, and the single deck configuration shown in Figure 9. In the case of the double deck, the sections considered were either circular or modified ellipses. The circular section is easy to manufacture and resists pressurization more efficiently, while the elliptical section uses material more efficiently.

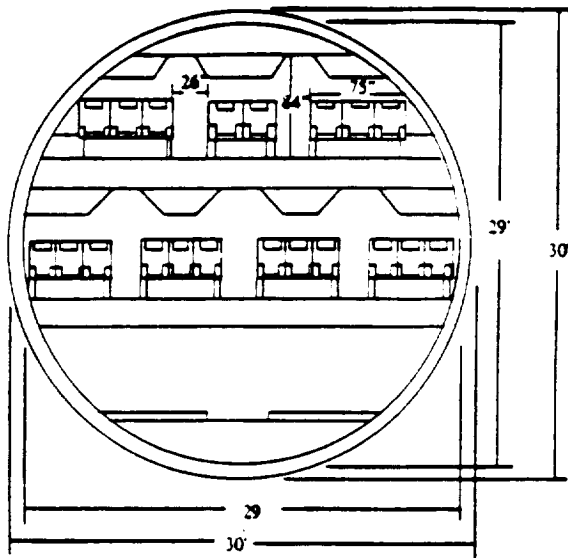

Figure 8 - Double deck fuselage design (Hastings 1066)

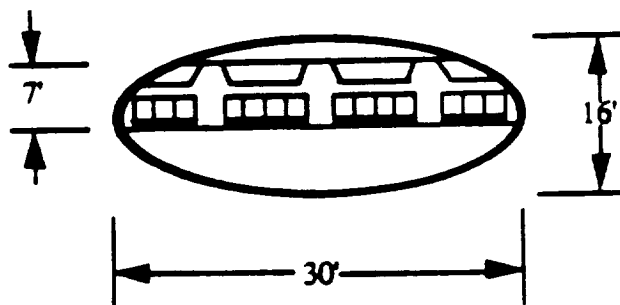

Figure 9 - Single deck fuselage design - (LINK-92)

In both cases, cargo storage is a criteria, as is the ability to provide a carry-through structure. With so many passengers on board, internal traffic patterns must be considered. Also, the requirements placed on a cargo hold to carry so much baggage are severe. The megatransport then has very little volume for other revenue producing cargo.

The issue of safety during evacuations is a concern when using the double deck configuration. The exits are high off the ground and require long chutes that weigh more than standard chutes. The issue of evacuation and creative solutions to this problem need to be addressed in the future.

Engine design

Engine design is an integral part of the senior design course at Purdue. Each group was required to design an engine around a baseline engine provided to them. Design included the design of the engine cycle and included specifying the turbine inlet temperature, compressor pressure ratio and engine bypass ratio.

Engine design efforts were supported by the ONX and OFFX analysis programs mentioned earlier. The TSFC at cruise altitudes ranged from a low of 0.495 to a high of 0.540. Bypass ratios between 8 and 10 were common.

The design groups took the take-off requirements to be from Denver on a hot day as their most severe take-off condition. This off-design condition for the engine created a conflict with the desire to cruise efficiently. As a result, the engines generated far more thrust than necessary to take-off.

An example of the size of the engine designed for this aircraft is given in Figure 10. This engine, the JG-1996-83K turbofan, was designed by Jason Gries. It is a two-shaft high bypass ratio turbofan with separate converging exhaust ducts. The single stage fan and a 3 stage low pressure compressor are driven by the same 4 stage low pressure turbine.

This engine can generate 83,500 lbs. of thrust at sea level and has a TSFC of 0.554 at cruise. The engine used a turbine inlet temperature of 3100 deg. Rankine at sea level and 2900 deg. Rankine at cruise. The bypass ratio is 8.5.

The weight of this engine is estimated to be 12,150 lbs. This includes the engine core, the nacelle, plumbing and thrust reversers. The total length of the engine is seen to be 14.4 feet with an engine diameter of 10.9 feet. This engine diameter and the fact that the engine is suspended from the wing required a landing gear length of 15 feet for the aircraft this engine was attached to.

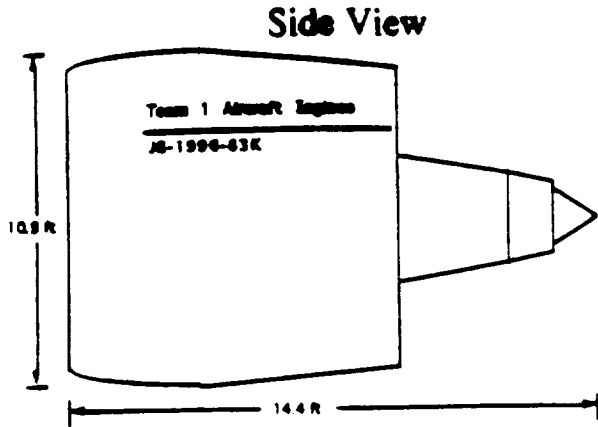

Figure 10 - JG-1996-83K Megatransport engine

Aerodynamics

For the operator and the passenger, the fuselage is the heart of the airplane. However, for the engineer, it is the wing that makes or breaks the design. The wing design is affected by considerations of performance, such as landing, take-off and cruise. On the other hand, the wing design must take into consideration added weight and the ability to house fuel and landing gear as well as carry engines.

Most of the team designs used wing loadings near 150 lb. per square ft. This wing loading allows the aircraft to operate efficiently at cruise, however, at landing and take-off leading edge and trailing edge devices must be used to operate at the airfields specified in the RFP's.

The primary trade-offs for wing design are airfoil thickness to chord ratio, wing sweep and aspect ratio. In addition, taper ratio is also a consideration.

Wing placement on the fuselage is a consideration also. In the vertical plane of the design, the wing may be placed high on the fuselage, in the middle of the fuselage or low on the fuselage. There are advantages and disadvantages to all of these choices.

The megatransport designs generated by the teams used a variety of wing mounting positions. The high wing position was popular because the engines could be mounted under the wings and still have ground clearance with relatively short gear. In some cases, the low wing position was combined with engines mounted over the wings to take care of ground clearance.

The main problem with high mounted wings is that the engines are mounted in line with the passenger cabin,

creating the possibility of noise transmission into the cabin. The teams choosing the high wing did not regard this as a serious problem.

All teams used supercritical airfoils. The cruise Mach number were all in the range of 0.87. The designer of the DAC-701 wing, Mark Manglesdorf, used the Roncz TFB-3 airfoil, shown in Figure 12. This airfoil has a drag divergence Mach number about $M=0.77$. It is 13% thick at the 50% chord position. At the design point of $M=0.75$ this supercritical airfoil is predicted to have about one-third more usable lift coefficient with about one-third less pitching moment, compared to a typical NASA supercritical airfoil.



Figure 12 - Roncz TFB-3 airfoil cross-section

To operate efficiently at the design cruise speed the wing must trade thickness and sweep. Increasing wing thickness reduces wing weight while it reduces the drag divergence Mach number. On the other hand, increasing the wing sweep will increase the drag divergence Mach number, but will increase the weight. In addition, increasing the wing sweep, all other parameters held fixed, will help the wing fit into gate areas.

Figure 13 shows the Hastings 1066 wing planform. This wing design is mounted low on the aircraft fuselage and has wing mounted engines.

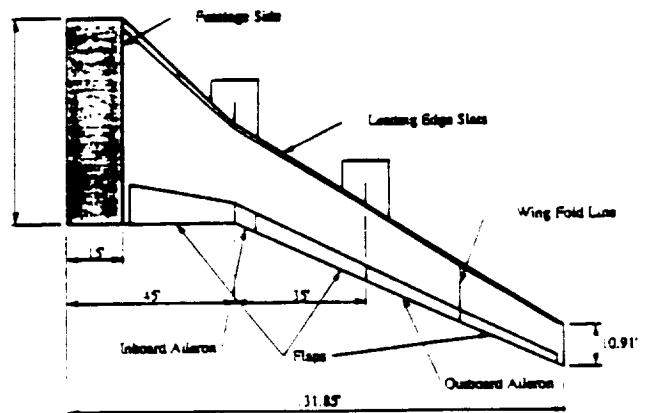

Figure 13 - Hastings 1066 wing planform

This wing has a planform reference area of 7320 sq. ft. and operates at a cruise lift coefficient of about 0.55. (This compares with the DAC-701 design wing lift

coefficient at cruise of 0.49.) The mean thickness to chord ratio of this wing is 0.11, with the wing root being 13%, the thickness at the kink is 11% and the thickness at the tip being 8%.

Cost and price data

Because the School of Aeronautics and Astronautics has an Air Transportation program, the issues of price and cost of aircraft and the cost of operations are emphasized. Cost of production and cost of operation are fed back to the RFP to make sure that what is being asked for is realistic.

The team member responsible for economic success of the project must choose a price for the aircraft based upon the number of aircraft he/she sees as a market. If the number of aircraft produced is large, then the cost per aircraft and the price per aircraft will be low. Figure 14 shows the relationship of cost per aircraft to the number produced, generated using the DAPCA IV model suggested by Raymer.⁶

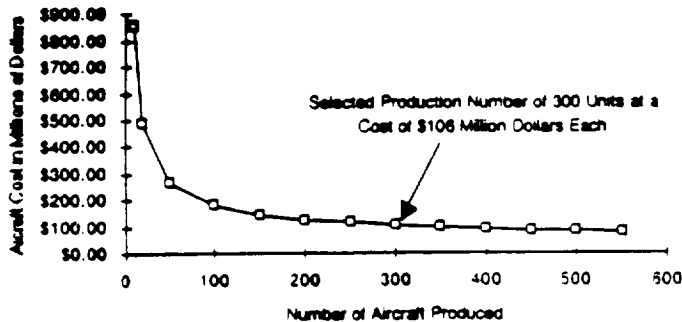

Figure 14 - Aircraft unit cost vs. number produced (JM-90P)

As noted previously, the market for this type of airplane is estimated to be about 550 units by 2010. On the other hand, a company cannot be expected to capture the entire market. Design teams estimated as few as 200 units and as many as 400 units that they could sell. As a result, the prices of the aircraft varied from \$144 million to \$179 million. This compares with a price of about \$130-\$140 million for the B-747.

Spreadsheet software has been developed, with the assistance of Professor J.W. Drake, to estimate DOC and to use a cash flow analysis to compute the price of the aircraft.⁷ This cost estimation requires a knowledge of basic operational characteristics of the aircraft.

An example of the cash flow analysis used to estimate the price of an airplane is shown below in Figure 15. This figure plots the money invested in the production program as a function of time. During this time, costs are being incurred for engineering and production, but

sales of aircraft are only beginning. As a result, the cash flow is out of the company (negative) and a "cash bucket" results.

The price of the aircraft is also sensitive to market conditions. The so-called "cost of capital" or interest rate has a strong effect on the price of the aircraft. Figure 15 shows the effect of this cost of capital on break-even price.

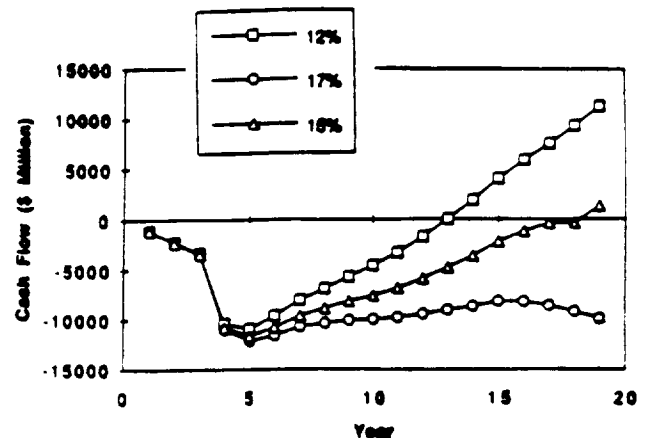

Figure 15 - The cash flow for an aircraft program, plotted against year from program start, at 3 different costs of capital (DAC-701)

The DAC-701 serves as an example of the determination of aircraft price. The selling price for the DAC-701 is \$166 million based on 15% cost of capital. Their program assumed a 19 year production run. The average production cost per aircraft was determined to be \$103.15 million based on a production run of 400 aircraft. The break-even price for their program is \$163.5 million dollars.

Conclusion

Two Purdue design classes considered the engineering and economic tasks of designing a megatransport aircraft. Market considerations drove the designs to over 600 passengers and ranges greater than 6000 nautical miles.

Due to the emphasis placed upon the use of existing airport facilities, many airplanes were of unconventional design. The use of supercritical airfoils and composite materials was considered as methods of reducing weight. The result was decreased acquisition cost and operating costs.

The megatransport design task requires more careful study of infrastructure/aircraft cost trades. For instance, the decreased operating costs and acquisition costs of the aircraft when wing span and landing gear footprint are

allowed to grow should be traded against the cost to re-configure airports.

As aircraft grow in size, the effects of the square-cube law on the structure absolutely demands a fresh look at advanced, integrated configurations. Most teams accomplished this task, but to differing degrees. The issue of interfering three surface airfoils is the most challenging and has the largest potential for payoff.

In addition, reduced weight from advanced technology, even though risky from a maintenance standpoint, requires a look at concepts such as fly-by-wire and more composite materials in the primary structure.

Acknowledgments

The opinions expressed in this paper are solely those of the authors and the students involved in this project. In addition, the authors recognize the individual and group efforts of the 73 students who participated in the project. Finally, we wish to acknowledge the support of NASA and USRA for funding provided as part of the Advanced Design Program.

References

1. "1992 Current Market Outlook - *World Market Demand and Airplane Supply Requirements*," Boeing Commercial Airplane Group, Seattle, Washington, February 1992.
2. "Outlook for Commercial Aircraft 1991-2010," Douglas Aircraft Company, Market Assessment, Long Beach, California, January 1992.
3. Cleveland, F.A., "Size Effects in Conventional Aircraft Design," *Journal of Aircraft*, Vol. 7, No. 6, Nov.-Dec. 1970.
4. Keith-Lucas, D. "Defeating the Square-Cube Law," *Flight International*, Vol. 94, No. 3106, Sept. 1968, pp.440-442.
5. Mattingly, J.D., Heiser, W.H., and Daley, D.H., *Aircraft Engine Design*, American Institute of Aeronautics and Astronautics, Washington, D.C., 1987.
6. Raymer, D.P., *Aircraft Design: A Conceptual Approach*, American Institute of Aeronautics and Astronautics, Washington, D.C., 1989.
7. Drake, J.W., Course Notes: *AAE 210 - Introduction to Air Transportation*, School of Aeronautics and Astronautics, Purdue University, West Lafayette, Indiana, 1990.

Special thanks to the following teams:

Fall 1991

Hastings 1066 - Arnold, Boddy, Lee, Muller, O'Keefe, Thomas

WB-670 - Chlystun, Lighthill, Rose, Stokman, Weissmuller

Twin-600 - Moore, Pardieck, Sandys, Scheitlin, Vaughn

Spring 1992

LiNK-92 - Mencone, Myers, Struckel, Weltzer, Winkleman

JM-90P - Gruber, Minniiti, Nebuda, Spangler, Wilson

TLS-5880 - Alcenius, Courtney, Greenwald, Halgren, Heinimann, Peters

DAC-701 - Frotton, Jankowski, Manglesdorf, Pongracic, Queiser

AAE 451
Aeronautical Design - Professor Weisshaar
Spring semester 1992

Course outline

The project this semester will involve the design of a megatransport aircraft to carry 600-750 passengers long distances. During the first few lectures we will discuss what this transport is intended to do. We will then develop an RFP (Request for Proposal) to define the design problem. The following is a preliminary course plan. Please note that we never choose exactly the same project from one year to the next so there are some uncertainties in this schedule. We will update this schedule as we go along.

The class meets on Tuesdays and Thursdays. It is particularly important that you attend class and be on time. **Tuesday morning classes will begin promptly at 8:30 a.m. Only one unexcused absence from this Tuesday morning class will be permitted.** Normally, no Tuesday afternoon lectures will be given after the fifth week of class. These times will be reserved for group meetings. Thursday afternoons will be reserved for lectures. **Only two excused or unexcused absences from the Tuesday/Thursday p.m. lectures will be permitted.**

Class final grades will be assigned on a competitive basis. One-half the final grade in the course will depend upon the combination written final report and final oral presentation. The other half will depend upon class participation, written assignments and oral presentations given during the semester.

Week One

Introduction- getting organized - student/instructor course expectations. Overview of the general design process. Introduction to sources of information. Discussion to acquaint the student with the design project definition. Weight estimation using information from Roskam design paper and textbook series.

Decision making. **Design team survey information must be completed by Thursday January 9.** First assignment distributed (weight estimation). Due next Tuesday.

Week Two

Discussion of general design requirements and objectives - history - economics - technology. Discussion of results of weight estimation assignment. Discussion of **Raymer cost estimation information.**

Estimating lift and drag. Homework assignment due next Tuesday. Estimation of program costs and aircraft costs for selected ranges and passenger loads.

Thursday : generating a drag polar from weight information.

Week Three

Lecture by Mr. John Roncz. Assignment to design teams consisting of aerodynamics (AE), performance (PE), economics and systems (EC), stability, control and balance (SC), propulsion and engine/airframe integration (PR), and structures, materials, loads and weights (ST).

Trade-offs between weight and aerodynamic performance. Discussion of the constraint diagram - why we need it - how to use it and how to generate it. Take-off, climb, cruise, landing as design issues.

Team assignment: sketch at least three different candidate configurations for this design. Include one conventional design. Be as specific as possible with dimensions and weights. At the end of the week you should be able to estimate the weight, program cost and drag polar for a given mission. You should be getting to know your team members. You should also understand how to generate a constraint diagram and understand what it is used for.

Week Four

Workshop by Mr. B.D. Nelson, Nelson Associates Tuesday morning and afternoon. Evaluation of preliminary designs. Thursday: Lecture on Russian Space Program.

Week Five

Technical writing and oral presentations. Weight calculation. Sources of information. Beginning a weights and balance sheet and its relationship to stability and control.

Week Six

Stability and control. Weight distribution and balance. Thursday - Use of PANDA and LINAIR to compute wing performance.

Week Seven

Tuesday morning - Team RFP presentations. Economics. Materials selection. Ethics, data presentation and other scary things.

Week Eight

Tuesday morning- Robert Matson (USAir) discussion of propulsion, operations and maintenance requirements. Oral design updates on Tuesday. Written reports on introduction and RFP plus technology and state-of-the-art. **Thiokol final reports will be due at 5 p.m. March 27. Thursday: landing gear requirements and risk taking.**

Notice - Constraint program can be accessed on gn computer by typing cp /gn2/aae251/conjet.f . The sample data that goes with the file is stored as the file condat.

Week Nine

Spring break.

Week Ten

Tuesday - Economics with Professor Drake. Written progress summaries due Wednesday March 11 at 11:30 a.m. Outline of Thiokol report is due on Friday. This outline should list sections to be included and summaries. Also include a list of Tables and Figures. A figure may not appear later if it is not on this list.

Week Eleven

Tuesday - Summary of overall design and design decisions. **Oral reports on propulsion system. Estimates of TFSC and description of engine design.** Material selection lecture. **First draft of Thiokol report is due on Friday.**

Week Twelve

Tuesday - Oral reports on wing design and aircraft predicted performance. Final Thiokol report is due 1:00 p.m. Friday.

Week Thirteen

Tuesday - Oral reports - design summary/ overview of economics, cost and price. Freeze design configuration on Friday.

Week Fourteen

Tuesday - Stability and Control and Structures/weights. Final report outline with list of tables and figures and chapter/section detail due at 8:30 a.m. in class Tuesday. A list of figures to be used in the final oral presentation is also due Thursday in class.

Week Fifteen

The first draft of the final written reports are due at 2:30 p.m. on Thursday, April 16.

Week Sixteen

Final drafts of design reports are due Friday April 24

April 27, 28, 29 Final TV taped oral presentations Potter studios !!!!