

NASW-4435

111-211

141689

P. 245

Conceptual Design of a Fleet of Autonomous Regolith Throwing Devices for Radiation Shielding of Lunar Habitats

Submitted to:

Mr. Dennis Wells
Automation and Robotics Division
Universities Space Research Association (USRA)
National Aeronautics and Space Administration (NASA)
Johnson Space Center, Houston, Texas

N93-17806

Unclass

G3/54 0141689

Prepared By:

Karem Armstrong
Daniel A. McAdams
Jeffery L. Norrell (Team Leader)

Mechanical Engineering Department
The University of Texas at Austin
Austin, Texas

Spring 1992

(NASA-CR-192078) CONCEPTUAL DESIGN OF A FLEET OF AUTONOMOUS REGOLITH THROWING DEVICES FOR RADIATION SHIELDING OF LUNAR HABITATS Final Report (Texas Univ.) 245 p

487799

ACKNOWLEDGMENTS

The design team members wish to thank the National Aeronautics and Space Administration and the Universities Space Research Association (NASA/USRA) for sponsoring this project.

We also thank Mr. Dennis Wells, our contact engineer at Johnson Space Center, for his assistance throughout the semester. Mr. Wells helped clarify our design problem and gave us much needed guidance during the research process.

A special thanks goes to Dr. Kristin Wood, our faculty advisor, for his support and advice. We thank Dr. Wood for his advice on technical matters and on controlling the scope and content of our project. Also, we thank Dr. Wood for being available to us any time that we needed assistance.

The design team thanks Mr. Barney Roberts of the Planet Surface Systems department at Johnson Space Center. We thank Mr. Roberts for providing us with documents containing vital information that was needed to complete the design.

We also thank Mr. Rich Hooper at the University of Texas at Austin for his assistance in performing a computer simulation of our design.

We also thank Mr. Hank Kleespies, Mr. Bert Herigstad, and Mr. Wendell Deen. We thank Mr. Kleespies for his constructive criticism and moral support throughout the semester. Thanks go to Mr. Bert Herigstad for providing administrative services and material. The design team thanks Mr. Deen for his assistance in producing effective and clear graphics.

Finally, we thank Dr. Steven P. Nichols for overseeing the Mechanical Engineering Design Projects Program and providing informative and entertaining lectures on the many different aspects of engineering.

EXECUTIVE SUMMARY

The National Aeronautics and Space Administration (NASA) in conjunction with Universities Space Research Association (USRA) has requested that the feasibility of a fleet of regolith tossing devices designed to cover a lunar habitat for radiation protection be demonstrated. The regolith, or lunar soil, protects the lunar habitat and its inhabitants from radiation. Ideally, the device will operate autonomously in the lunar environment.

To prove the feasibility of throwing regolith on the Moon, throwing solutions were compared to traditional, Earth-based methods for moving soil. Various throwing configurations were investigated. A linear throwing motion combined with a spring and motor energizing system proved a superior solution. Three different overall configurations for the lunar device are presented. A single configuration is chosen and critical parameters such as operating procedure, system volume, mass, and power are developed.

The report is divided into seven main sections. First, the Introduction section gives background information, defines the project requirements and the design criteria, and presents the methodology used for the completion of this design. Next, the Preliminary Analysis section presents background information on characteristics of lunar habitats and the lunar environment. Then, the Alternate Designs section presents alternate solutions to each of the critical functions of the device. Fourth, a detailed analysis of throwing the regolith is done to demonstrate its feasibility. Then, the three overall design configurations are presented.

Next, a configuration is selected and the conceptual design is expanded to include system performance characteristics, size, and mass. Finally, the Conclusions and Recommendations for Future Work section evaluates the design, outlines the next step to be taken in the design process, and suggests possible goals for future design work.

TABLE OF CONTENTS

	PAGE #
ACKNOWLEDGMENTS	ii
EXECUTIVE SUMMARY.....	iv
TABLE OF CONTENTS	vi
LIST OF FIGURES	ix
1.0 INTRODUCTION	1
1.1 Background Information.....	2
1.2 Project Requirements.....	4
1.3 Design Criteria	5
1.3.1 Physical Criteria.....	5
1.3.2 Environmental Criteria.....	5
1.3.3 Task Specific Criteria.....	6
1.4 Design Methodology	7
2.0 PRELIMINARY ANALYSIS.....	9
2.1 Habitat Characteristics	9
2.2 Characteristics of Lunar Environment.....	10
2.2.1 Radiation.....	10
2.2.2 Temperature.....	11
2.2.3 Micrometeorite Impact	12
2.2.4 Vacuum.....	12
2.2.5 Gravity.....	12
2.3 Characteristics of Lunar Soil	12
3.0 ALTERNATIVE DESIGNS.....	14
3.1 Introduction.....	14
3.2 Transportation and Placement of Regolith.....	16
3.3 Collection of Regolith.....	27
3.4 Vehicle Mobility and Locomotion	33
3.5 Vehicle Navigation and Location	38
3.5.1 Absolute Positioning	39
3.5.2 Relative Positioning	44

TABLE OF CONTENTS (CONTINUED)

	PAGE #
3.6 Determination of Finish Point.....	46
3.7 Powering of Unit.....	49
3.7.1 Power Generation.....	50
3.7.2 Power Conversion.....	53
3.7.3 Recharging of Unit.....	53
3.8 Coordination of Multiple Units.....	55
3.9 Obstacle Identification and Avoidance.....	56
3.10 Cooling and Heating of Unit.....	59
3.11 Cleaning of Lunar Dust from the Unit.....	61
3.12 Storage of Unit.....	63
4.0 DETAILED ANALYSIS OF REGOLITH PLACEMENT METHOD.....	65
4.1 Feasibility of Throwing.....	65
4.2 Comparison of Linear and Rotational Throwing.....	72
4.3 Throwing Energizing Methods.....	74
4.3.1 Chemical Propellants.....	74
4.3.2 Electric Motor.....	75
4.3.3 Flywheels.....	75
4.3.4 Magnetic Fields.....	76
4.3.5 Springs.....	76
4.3.6 Selection of Energizing Method.....	77
5.0 OVERALL DESIGN CONFIGURATIONS.....	78
5.1 Selection of Alternative Solutions.....	79
5.1.1 Powering.....	79
5.1.2 Mobility.....	80
5.1.3 Cleaning of Lunar Dust.....	80
5.1.4 Coordination of Multiple Units.....	81
5.2 Overall Design Configuration #1.....	81
5.3 Overall Design Configuration #2.....	83
5.4 Overall Design Configuration #3.....	85
5.5 Configuration Selected for Computer Simulation.....	87

LIST OF FIGURES

FIGURE #		PAGE #
1.	Schematic of lunar habitat.....	4
2.	Cross-sectional view of proposed habitat	9
3.	Conveyor belt and bucket assemblies	17
4.	Circling conveyor belt mechanism	19
5.	Dumping of regolith on top of lunar habitat.....	20
6.	Transportation and placement by hopping device.....	21
7.	Mechanical throwing arm.....	23
8.	Crossbow or slingshot configuration	24
9.	Impact mechanism.....	25
10.	Magnetically-driven arm.....	26
11.	Railgun throwing mechanism	27
12.	Standard earth-moving equipment.....	28
13.	Bulldozer modification.....	29
14.	Sweeping mechanism	30
15.	Ferris wheel arrangement for gathering of regolith.....	31
16.	Scarifier and auger mechanisms.....	32
17.	Wheel geometries.....	34
18.	Examples of half-tracks and tracks	36
19.	Angle measurements for multiple point resection calculations.....	41
20.	Azimuthal angle.....	42
21.	Beacon network configuration	44
22.	Configuration of sensors on poles.....	47
23.	Regenerative fuel cell process description.....	52
24.	Mechanical bumper.....	58
25.	Spring-loaded pole configuration	58
26.	Paths of motion of a particle thrown on the Moon as compared to the Earth	66
27.	Work comparison between throwing and carrying.....	69

LIST OF FIGURES (CONTINUED)

FIGURE #		PAGE #
28.	Overall design configuration #1.....	82
29.	Overall design configuration #2.....	84
30.	Overall design configuration #3.....	86
31.	Scaled configuration for computer simulation.....	88
32.	Volumetric rate of collection per unit vs. number of units...	90
A1.	Function structure of lunar device.....	A2
B1	Impact force vs. impact duration.....	B3
B2	Impact stress vs. impact duration.....	B3
B3	Area causing load stress on habitat.....	B5
C1	Horizontal position vs. time.....	C7
C2	Vertical position vs. time.....	C7
C3	Paths of motion of a particle thrown on the Moon as compared to the Earth.....	C4
C4	Paths of motion of a load thrown on the Moon at various launch angles.....	C10
D1	Use of conveyor belt to move regolith.....	D17
D2	Loader method for positioning regolith on the habitat.....	D16
D3	Radius of the area that must be cleared as a function of depth of dig.....	D20
D4	Work to move regolith as a function of depth of dig.....	D20
D5	Work to move regolith as a function of surface area cleared	D21
F1	Direct connection throwing solution.....	F3
F2	Spring-motor arrangement.....	F6
F3	Required torque to compress spring as a function of number of rotations.....	F8
F4	Launch geometry.....	F9
F5	Flywheel energy.....	F10
F6	Flywheel mass as a function of torque required.....	F12
F7	Motor torque as a function of flywheel diameter.....	F12
G1	Variable definition for volume of regolith calculations.....	G2
H1	Volumetric rate per unit vs. number of units.....	H3

LIST OF FIGURES (CONTINUED)

FIGURE #		PAGE #
J1	Definition of variables for wheel traction.....	J3
J2	Net traction as a function of wheel width	J5
J3	Traction as a function of wheel radius.....	J6
J4	Traction as a function of device mass	J6
J5	Width of cut on area A.....	J7
J6	Cutting force as a function of blade width.....	J9
J7	Cutting force as a function of cutting angle	J10
J8	Cutting force as a function of bucket height.....	J10
J9	Cutting force vs. depth of cut	J11
K1	Time per cycle vs. launch volume	K3

INTRODUCTION

The Universities Space Research Association (USRA) and the National Aeronautics and Space Administration (NASA) are the sponsors of this project. USRA is a private, non-profit organization created by the National Academy of Sciences in 1969. USRA consists of 58 universities, such as the University of Texas at Austin, across the United States, and promotes research in space science and technology at these universities. USRA also directs several programs for NASA. One of these programs is the Advanced Design Program. This program joins engineering students and faculty with engineers from NASA or other industry participants. Design problems, for a senior design team to address during a semester, are solicited from NASA or the other participants. The sponsoring organization provides the student team with technical expertise and consultation throughout the design project's duration. At the conclusion of the project the design team submits a written report and makes an oral presentation.

USRA has both short term and long term goals for the Advanced Design Program. The short term goals are the implementation of procedures and policies that will be the basis for future development. There are several long term goals. One of these goals is the development of the engineering design curricula at the university level. The Advanced Design Program also gives university students a chance to work on real problems in a capstone senior design course. This program benefits both the engineering community and NASA.

In 1958, NASA was commissioned by the Federal Government for the exploration of space. During their 34-year existence, NASA has landed a space vehicle on Mars, sent six manned missions to the Moon, and has placed various military and industrial satellites into orbit around the Earth. Currently, NASA is considering a manned outpost on the Moon to be established by the year 2004 [1].* This manned outpost will provide excellent research opportunities for low-gravity experiments. The Moon also provides an excellent base for space observations. On Earth, the atmosphere can interfere with telescopic space observations. A lunar base will also enable the extraction of oxygen and hydrogen from the regolith, or lunar soil [2]. The lunar oxygen (LUNOX) will facilitate future space exploration. The LUNOX is crucial for life support and fuel for propulsion. With an established lunar base, the Moon can serve as an oxygen supply station for future space missions.

1.1 Background Information

The lunar environment provides unique design challenges. The day and night cycle corresponds to 29 Earth days. The surface temperature ranges between 114 K during lunar night to 390 K during the lunar day [3]. Other concerns are the near total vacuum and the intense radiation that the Moon experiences.

The intense radiation that the lunar base will experience is a key concern in the construction and existence of a lunar base. Solar flares and galactic cosmic rays (GCRs) can provide over twice the dosage needed to kill a human. Solar flares are explosions of the sun's chromosphere

* References begin on page 101 of this report.

resulting in the expulsion of high-energy protons. GCRs are an omnidirectional flux of protons, alpha particles, and heavier nuclei which arrive from interstellar sources such as supernovae. Average radiation doses on the lunar surface are approximately 60 rem/year [4]. Any habitat placed on the Moon needs shielding from this radiation. A proposed method of shielding consists of covering the habitats with a layer of regolith (see figure 1). A 50 cm regolith shield has been predicted to reduce the unshielded radiation dose by 60% thus providing the necessary protection [5]. In addition, the use of a regolith shield removes the need for transportation of material from the Earth and protects the habitat from micrometeorite impacts.

The project of the mechanical engineering design team is to develop a method to automatically cover a lunar habitat with the needed regolith. An example of such a method is a fleet of "robots" that independently "toss" regolith on the habitat. Other possible uses for regolith gathering methods are processing and extracting LUNOX, aiding the construction of lunar roads, and excavation of exploded craters for habitat placement.

The low gravity and near vacuum lunar environment provide several advantages to using tossing as the regolith placement method. The low gravity environment allows for throwing the regolith at slower velocities than if it was thrown on Earth. By using slower velocities, less power will be consumed. The lack of atmosphere on the Moon removes drag, thus decreasing the tendency of the regolith to spread when thrown.

The feasibility of throwing over other regolith placement methods was studied. The best alternative was chosen for the final design.

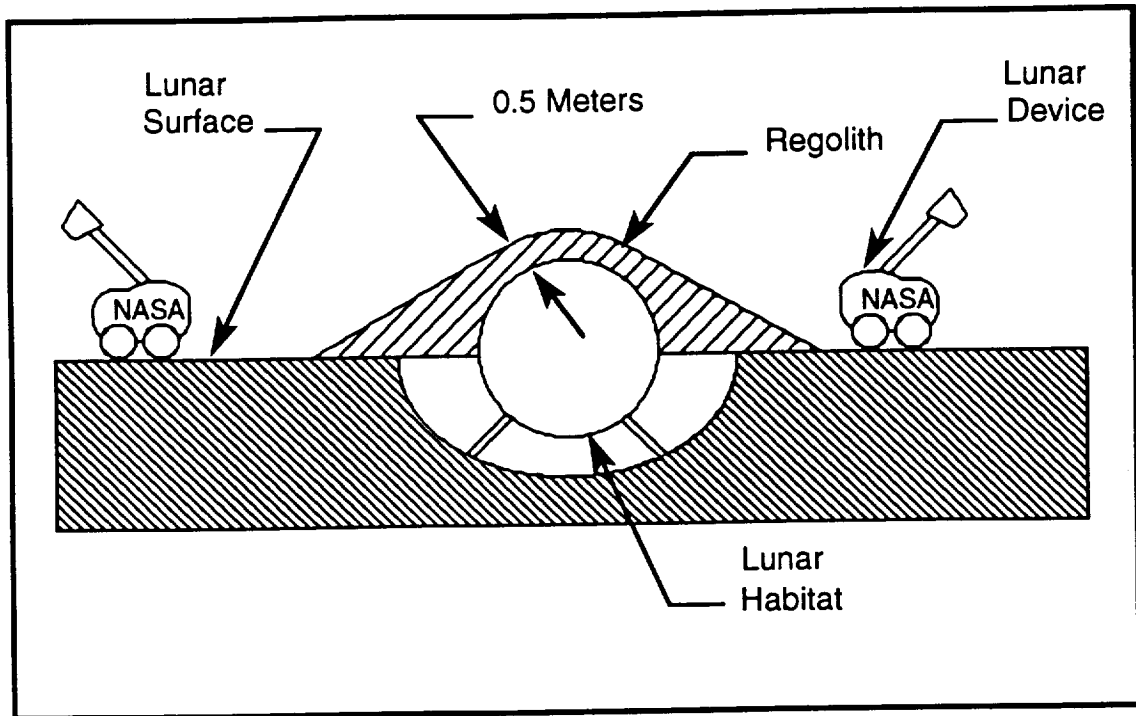

Figure 1. Schematic of Lunar Habitat.

1.2 Project Requirements

There are four main requirements particular to the project specified by NASA and the Universities Space Research Association (USRA). These requirements are:

1. Demonstrate feasibility of the concept of a fleet of small regolith tossing devices for the covering of lunar habitats.
2. Develop several conceptual designs for regolith placing devices.
3. Calculate power requirements, mass, size, and cost of the devices.
4. Construct a model demonstrating a specific design solution or use of specific technology.

1.3 Design Criteria

Design criteria are needed as a basis for rating the design solutions for these project requirements. The design criteria for this project were divided into three categories: physical, environmental, and task specific.

1.3.1 Physical Criteria

Physical criteria deal with the cost of having to transport the device to the Moon. The costs associated with launching objects into orbit are very high and must be minimized. Three criteria fit into this category. The design must have low mass. The design must have a long life. It is more economical to have an object with a long life, instead of relying on many redundant or replacement devices. The device must be storable and compact; the devices must occupy a minimal amount of cargo space during transport to the Moon. A storable, compact design potentially leaves room for other payloads.

1.3.2 Environmental Criteria

Environmental criteria deal with the device having to operate in the lunar environment. The rigors of the lunar surface include a near total vacuum, electrostatic dust, and intense radiation. The devices must be able to function and survive in this harsh environment. Several criteria fit into this category.

The lunar device needs to have a high efficiency. Fuel is difficult to obtain on the Moon. The provided fuel must be used sparingly and not wasted. A low power consumption is vital for the lunar devices. Adding

energy storage items, such as batteries, to the device will add mass. Low power consumption reduces the mass of the required energy storage devices.

The design must be robust to withstand and survive the lunar environment. The device must be stable to move around the lunar surface and fulfill its tasks without becoming inoperable, for example, by improper orientation for movement. If a device becomes momentarily inoperable, it must be able to right itself or it will no longer function.

The number of moving parts in the lunar units needs to be minimized. Lubrication of moving surfaces is a large problem on the Moon. The near total vacuum removes the water vapor that acts as a lubricant on the Earth. In addition, without perfect sealing any fluid lubricants will vaporize on the Moon. Such sealing is both difficult and expensive to obtain.

1.3.3 Task Specific Criteria

Task specific criteria deal with the device having to cover the lunar habitat with little or no human interaction. The device must have a high reliability. Initially, astronauts will not be on the Moon to repair a broken device, so the units must have a low failure rate. The units must be modular. A modular design will ease the repair of any components in the device and facilitate modifications of the device for other tasks by future lunar inhabitants. Such modifications increase the versatility of the devices. The device must be fully or partially automated. The design is to set up habitats before any humans are on the Moon. An automated device, reduces the problems seen with teleoperation from the Earth. With

automation, the time delay in communications between the Moon and the Earth is no longer a critical problem.

1.4 Design Methodology

This section outlines the solution methodology used to complete the design problem, based on the problem statement, project requirements, and design criteria discussed above. The steps included a literature search, a quantitative analysis of the design criteria, the development of alternative designs for critical functions of the device, a detailed analysis of the regolith placement method, the integration of the placement method into three overall design configurations, and the construction and demonstration of a model.

The initial phase of the design process consisted of reducing the initial problem statement to its critical design requirements and creating a functional description of the design. This abstraction revealed several essential functions that the device must perform. Appendix A presents a function structure showing each process the device must perform to achieve its objective.

With the essential problem clearly defined, a literature search and a patent search were performed. The literature search had two essential goals. The first goal was to gather information about the Moon and the lunar environment in which the unit will operate. Sources containing information about general lunar conditions and previous lunar machines were consulted. The second goal of the literature search was to gather

information about certain technologies that may be helpful to achieve a successful, robust design. Literature about autonomous devices and specific technologies that are used in autonomous devices, such as radar, light-emitting diodes (LEDs), inertial sensors, and visual sensors were consulted. A patent search was then performed. Reasons for performing a patent search were to obtain information about similar design efforts, to avoid patent infringement, and to explore options for design patentability.

The next step in the design process involved a quantitative analysis of the design requirements. Using the data found in the literature search, calculations were performed to investigate the physical necessities of the device. The lunar environment may be conducive to non-obvious design solutions and hostile to standard design solutions. Therefore, the design team performed analyses to determine what types of design solutions are preferred for lunar operations.

Due to the number of tasks that had to be done to complete this project, it was necessary to narrow the scope of the project to make it more tractable for a one semester design project. A detailed analysis was performed on the actual placement of regolith on the habitat. A qualitative analysis was performed on the other functions to select the most feasible alternative. After the most feasible alternative for each function had been selected, the regolith placement method was integrated into three overall design configurations. One of these configurations was then chosen for a demonstration model and a computer simulation, both of which will be presented in the project's final presentation.

PRELIMINARY ANALYSIS

2.1 Habitat Characteristics

The size and shape of habitat to be permanently based on the Moon has not been decided yet by NASA. A spherical habitat, 16 meters in diameter, has been proposed [6]. This habitat will be used as a base operations center, providing a living and working environment for a crew of twelve. Figure 2 shows a cross-sectional view of the habitat covered by the 0.5 m thick regolith layer. The overall dimensions of the proposed habitat are also included in the illustration.

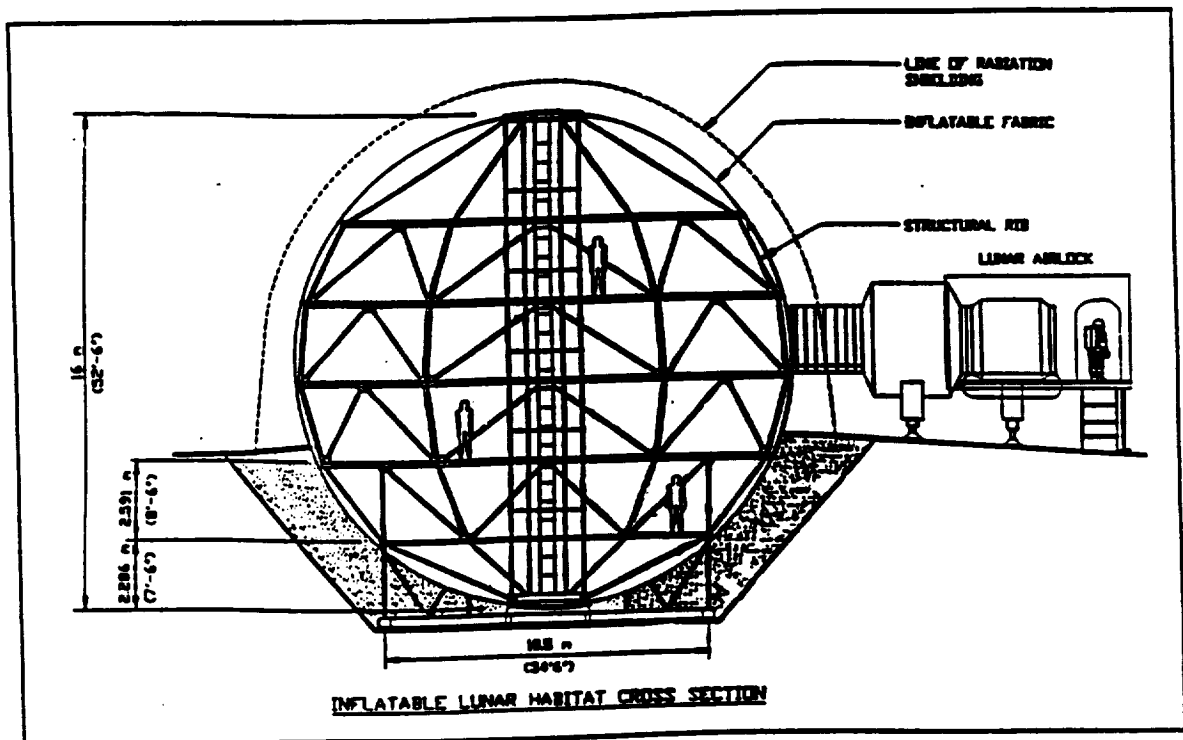

Figure 2. Cross-sectional view of proposed habitat. (Modified from [7])

The habitat is comprised of a spherical pneumatic envelope and an internal structure. A potential problem when using regolith as a radiation shield is the stress it may place on the habitat. This stress will be caused by the weight of regolith placed on the habitat and by the impact of the load when hitting the habitat. A preliminary analysis in these two areas showed that there will be no danger in penetrating the habitat with the load thrown or in the habitat collapsing due to the weight of the regolith (see Appendix B).

2.2 Characteristics of the Lunar Environment

The lunar environment provides unique design challenges. Radiation, temperature extremes, near total vacuum, micrometeorite impact, and lower gravity are the most critical factors affecting the design of lunar equipment. The following sections provide information about these factors.

2.2.1 Radiation

The radiation at the lunar surface is very different to that on the Earth because the Moon lacks both a strong magnetic field and a thick atmosphere [8]. With no atmosphere, natural radiation protection on the Moon is non-existent. Radiation hazards on the lunar surface come from two different sources: galactic cosmic rays (GCRs), which permeate the lunar environment at roughly constant levels, and solar energetic particle events that produce extremely high levels of radiation for short periods of

time. The heavy nuclei present in GCRs and the secondary particles that GCRs generate in the lunar soil require the use of shielding to protect humans and sensitive electronic equipment on the Moon. Energetic particles are generally a minor concern on the Moon. A few very large particle events generally occur each decade; However, these events are serious radiation hazards to humans and equipment [9]. The National Council on Radiation Protection has set a radiation upper limit for astronauts at 50 rem/year, and not to exceed 25 rem in a 30 day period. The average radiation dose at the lunar surface is about 60 rem/year [10].

Nucleon and heavy-ion transport codes have been used by Langley Research Center to estimate shielding requirements for lunar habitats. The effectiveness of a shielding material has been indicated by the variation of the delivered radiation dose as a function of the shield thickness required. For the predicted GCR dose, a 0.5 m thick regolith shield has been predicted to reduce the free-space dose by about 60 percent [11].

2.2.2 Temperature

The temperatures on the Moon ranges from 102 K at lunar night to 384 K at lunar noon [12]. Materials and equipment insensitive to these extreme conditions must be selected. Several problems are associated with extreme temperatures. High temperatures cause evaporation of materials and lubricants and low temperatures cause embrittlement of certain materials. Thermal gradients also cause large strains in most materials. All equipment reliant on lubrication must be carefully sealed so that the lubricant does not evaporate. To minimize thermal strains, materials with low coefficients of thermal expansion should be considered.

2.2.3 Micrometeorite Impact

The device should be protected from micrometeorite impacts. Meteorites are naturally occurring small solid bodies, traveling through space at high velocities. A rain of meteorites is constantly falling on the lunar surface. Impact frequency decreases very rapidly with increasing size. Micrometeorites between 1 to 10 mm are predicted to impact the lunar surface at a rate of 300/m² per year [12]. Micrometeorite impacts will damage exposed surfaces leading to premature equipment failure.

2.2.4 Vacuum

The absence of any significant atmosphere on the Moon causes a vacuum level of approximately 10⁻¹² torr which is near total vacuum [13]. The near total vacuum in the lunar surface may also cause several problems on the lunar equipment. Low pressures will cause evaporation of lubricants and other materials which have the problem described above.

2.2.5 Gravity

The acceleration of gravity on the Moon is about 1/6 of the gravity on Earth. This will cause objects on the Moon to weigh less than on the Earth.

2.3 Characteristics of the Lunar Soil

Lunar soil, also called regolith, is produced primarily by meteorite impacts on the lunar surface. The lunar regolith has grain size

characteristics similar to silty sand. The average particle size by weight generally varies from 0.04 mm to 0.13 mm [14]. Analogies have been made to fine-grained slag or terrestrial volcanic ash [15]. Lunar regolith has a very low electrical conductivity which permits accumulation of an electrostatic charge under ultraviolet irradiation. As a device moves around the lunar surface, clouds of electrostatically charged dust are formed. This dust accumulates and adheres to equipment affecting its performance.

The density of the regolith, or lunar soil, increases hyperbolically with depth. An average density of 1465 kg/m^3 was assumed for this analysis. This value was obtained by averaging the surface density and the density at the maximum depth of dig.

Much information about the lunar soil is not currently available. Soil properties and lunar surface characteristics at the outpost site were assumed to be similar to the Apollo 11 landing site.

ALTERNATIVE DESIGNS

3.1 Introduction

This section addresses the alternate solutions generated for each of the critical functions that need to be performed by the device. Using the design requirements and the function structure as guidelines, the main task of the device was reduced to five primary functions and six secondary functions. Primary functions are those which are critical in providing a material flow for the regolith. Secondary functions are those which are necessary to the overall success of the device, but do not enter into the material flow path. The critical path of material flow is the path between the initial collection of the regolith to the final position of the regolith on top of the habitat. The critical material flow is shown in the function structure in Appendix A.

The functions are discussed in decreasing order of importance. Primary functions are discussed first, followed by a discussion of the secondary functions. The five primary functions are gathering the regolith, transporting the regolith to the habitat and placing the regolith on the lunar habitat, mobilizing the unit, navigating and locating the unit and the habitat, and determining the endpoint for placing the regolith. The six secondary functions are powering the unit, coordinating multiple units, identifying and avoiding obstacles, cooling and heating the unit, cleaning lunar dust from the unit, and storing the unit. Although the functions addressed do not include each task the device must perform, these functions are those that are critical to the main objective of the device.

To provide a complete solution configuration for the device, alternative solutions are presented for each function. Advantages and disadvantages of each solution variant are discussed. However, a complete investigation of each alternative was not performed. Preliminary research into autonomous lunar devices showed that many of the critical functions have been addressed in previous design projects. In these projects the available technology was researched and investigated to select an optimal solution. When functions of previous lunar devices and this design are similar, solutions were chosen from previous research and analysis rather than repeating the investigation. An examination has been performed to determine functions that are particular to this device. The particular functions include transporting the regolith to the habitat and placing the regolith on the lunar habitat. Alternative solutions for transporting regolith to the habitat and placing regolith on the lunar habitat include methods that "toss" and methods that transport or carry. Because the feasibility of "tossing" devices was investigated, solution alternatives that do not "toss" are generated to serve as a comparison for the "tossing" concept.

An overall system configuration is not presented in this section. In several cases it is impractical, or unfeasible, to link certain function solutions with a specific solution to a different function. For example, using hopping for locomotion prevents the use of an axle-rotation counter for navigating and locating the unit. Another example is throwing instead of carrying the regolith. The viability of certain function solutions will change depending on whether the device throws the regolith or carries it.

3.2 Transportation and Placement of Regolith

The primary function of the device is to place the regolith on top of the habitat to provide radiation shielding. Transportation and placement of the regolith can be performed in two separate functions, by getting the regolith to the habitat and then placing it on top of the habitat; or combining both functions by throwing the regolith from the gathering location. Several alternatives were developed to perform this task in two separate functions. These methods are a conveyor belt, a bucket assembly, raising and then tilting a carrying mechanism, and hopping. These alternatives use a lunar device to collect and transport the regolith close to the habitat and then either dump the regolith onto a separate lifting mechanism, such as the conveyor belt, or place the regolith directly on top of the habitat. Dumping the regolith directly can be done with a system such as a front loader or by hopping. An advantage of carrying and dumping the regolith is that no long distance targeting or positioning system is needed. During travel back and forth from the habitat to the regolith gathering sites the device's location can be determined by using dead-reckoning (discussed in a later section). A disadvantage of carrying and dumping systems is that extra trips around the lunar surface may be needed, which can increase the power requirements of the system. The extra trips will be from the device going out to collect regolith and returning to dump the load. The device will be moving at times without a load which is a waste of energy.

The first alternative for placing the dirt on top of the habitat is dumping the regolith onto a conveyor belt or bucket assembly, both shown in Figure 3.

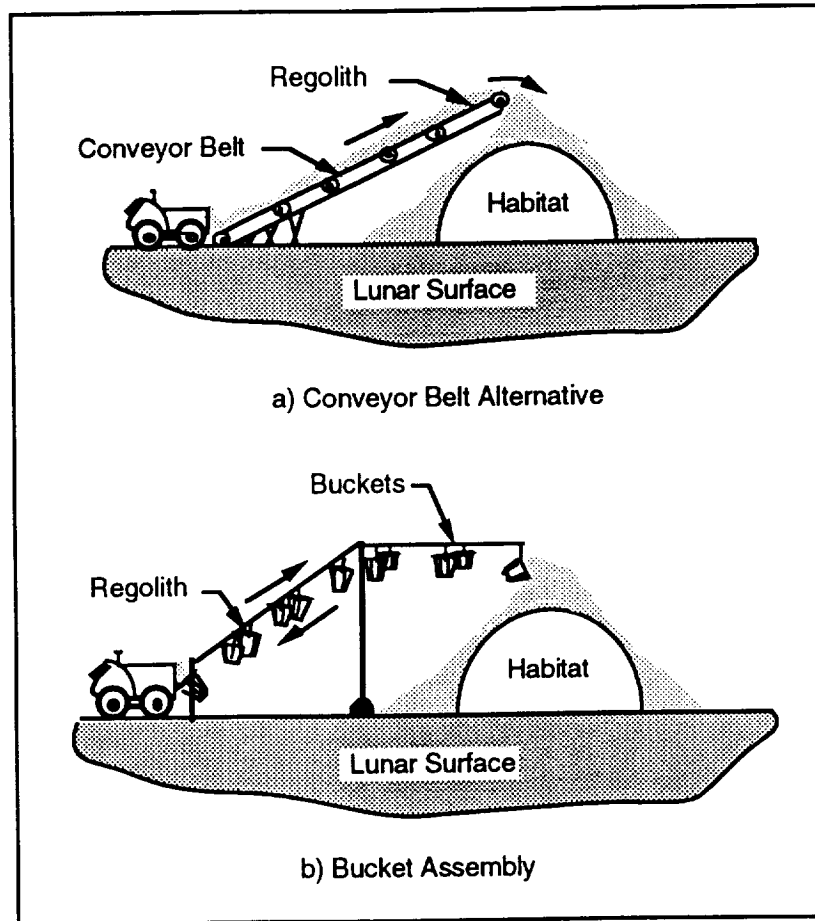

Figure 3. Conveyor belt and bucket assemblies.

The conveyor belt consists of a belt on rollers which transports the regolith from the dumping site to the top of the habitat. The belt is driven by a motor. An advantage of the conveyor belt is that it operates continuously. There are no energy losses from stopping and starting. A bucket assembly consists of buckets on a cable system suspended on poles. The bucket assembly is also powered by a motor. The mass of the bucket assembly will depend on the number of buckets used to carry the load. To avoid

coordination problems it will be convenient to have each bucket carry the same amount of regolith as the carrying mechanism, or to enable the buckets to gather the regolith from a dumped pile. There are several disadvantages of the conveyor belt and bucket systems. Two separate devices are needed to place the regolith onto the habitat. These systems must be large enough to reach the top of the habitat. This increased system mass raises the costs to transport the system to the Moon. Human interaction will also be needed to assemble the mechanisms and to initiate operations. Once the devices are in place, it will be difficult to relocate them. Also, both systems need a power source to drive the motors. Both systems also have a large number of moving parts, which increases the chance of mechanical failure.

A conveyor belt rotating on a track around the lunar habitat is another option for the regolith placement method (see Figure 4). As the assembly rotates it can sweep up the regolith around itself for collection. A separate device, connected to the conveyor belt, can then collect the regolith from the sides of the assembly. The collected regolith is then placed on the conveyor belt for placement on the habitat. A major disadvantage to this alternative is the large size and mass needed for the structure. The conveyor belt assembly needs to be large to reach the top of the habitat and will not be very modular. In addition, power is needed to rotate the belt assembly around the habitat. This alternative also contains a large number of moving parts, increasing the chances of mechanical failure.

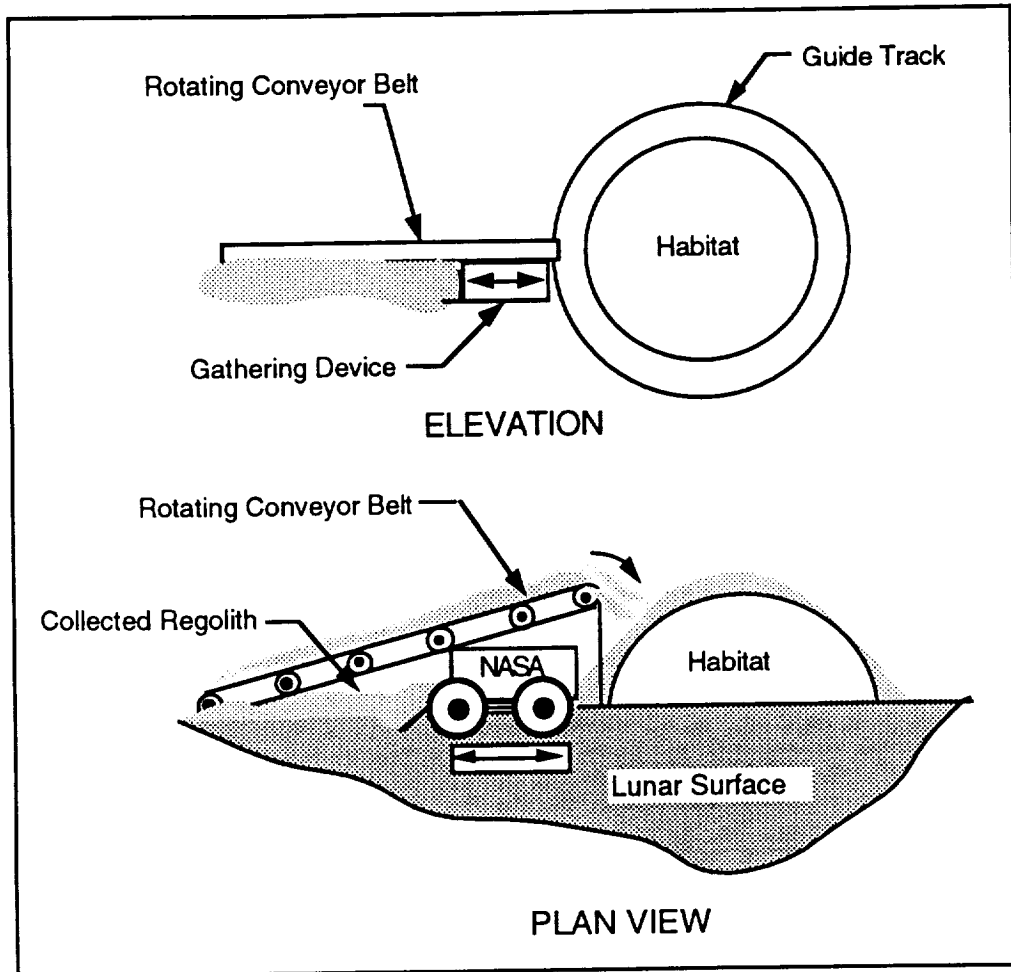

Figure 4. Circling conveyor belt mechanism.

Another alternative is a device that gathers the regolith, carries it to the habitat, and places the regolith directly on top of the habitat. The lifting mechanism is an integral part of the device. The most feasible option considered for this alternative is to have the regolith container elevate and then tilt, dumping the regolith on top of the habitat, as seen in Figure 5. A major disadvantage of this device is the size needed to reach the top of the habitat. An arm with a reach of at least 17 meters is needed to place regolith on the habitat. Such an arm will make this device unstable.

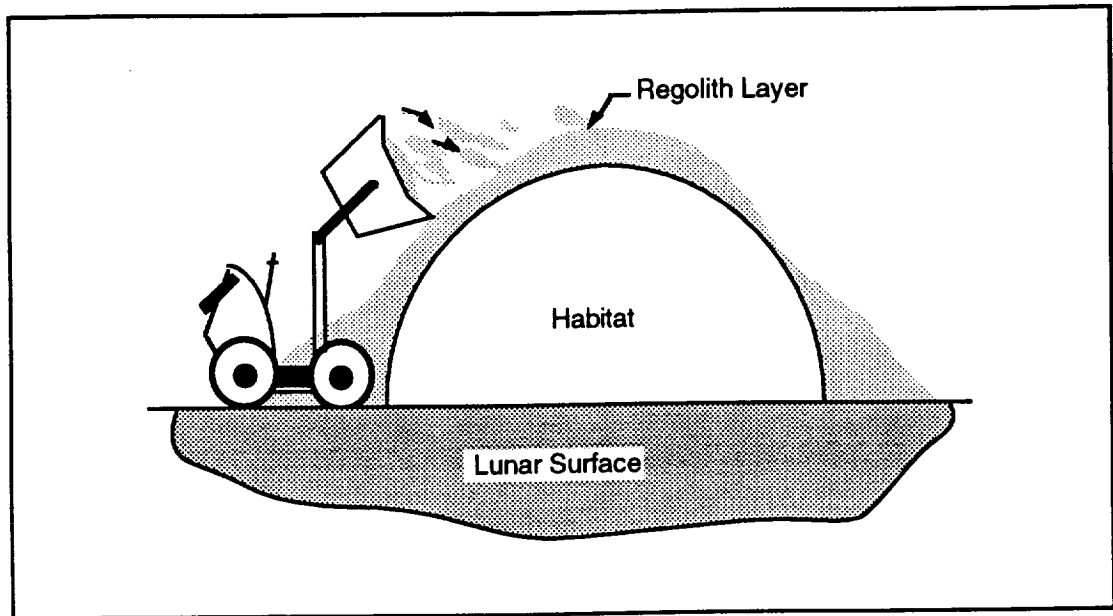

Figure 5. Dumping of regolith on top of lunar habitat.

The last carrying and dumping alternative is a device that moves by hopping. Shown in Figure 6, the device hops over the dome and then drops its regolith load while in mid-hop. An advantage to hopping is the ease of obstacle avoidance while hopping. The lunar device can hop over obstacles in its path. Hopping, however, is a very complicated method of motion. The device needs to plan its hops to ensure a safe landing. Therefore, the device will have to have prior knowledge of its landing point before a jump can be attempted. Such knowledge can only come from mapping, which has the difficulties discussed in a later section.

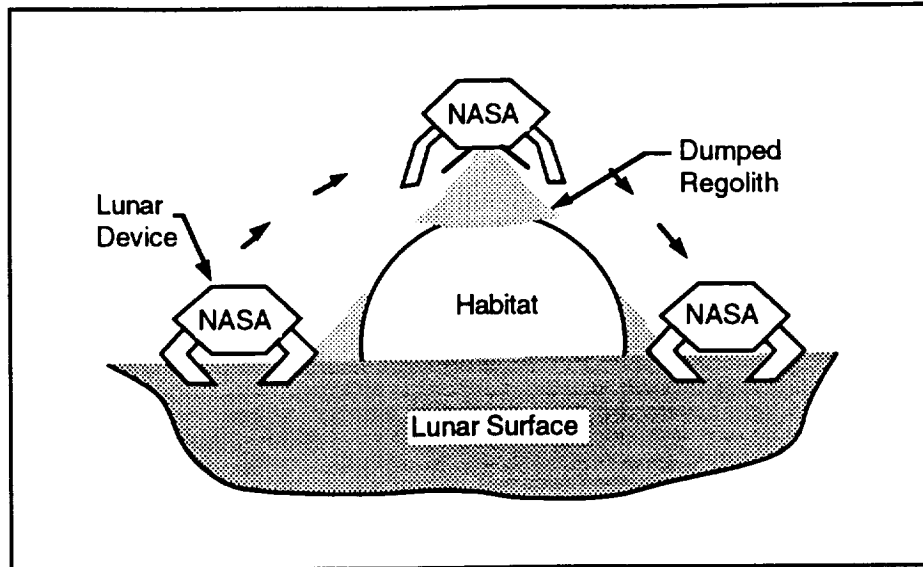

Figure 6. Transportation and placement by hopping device.

The second class of alternatives for the transportation and placement of regolith is throwing. Throwing the regolith has the advantage of accomplishing the transportation and placement of the regolith at the same time. Another advantage for throwing is that there is no wasted time or energy traveling back and forth from the habitat to the regolith collection site. There are no trips with an empty collection mechanism. The regolith is collected and then thrown directly from the collection site. The low gravity and near vacuum in the lunar environment also provide several advantages to throwing. For a given distance, the lower gravity, one-sixth of Earth's gravity, allows smaller forces for throwing. The lack of atmosphere on the Moon reduces drag, thus decreasing the tendency to spread of the thrown regolith. These factors will be discussed in more detail in Section 4.1.

Throwing the regolith has several disadvantages. A means of targeting, to find the range to and the location of the habitat, is needed if lunar dirt is to be thrown. Additionally, a launch speed or a launch angle has to be calculated when throwing. For a given distance, the speed and the angle are related to each other. The position of the device on the lunar surface will affect the launch angle. Therefore some method for the detection of level, such as a horizon sensor, is needed to enable the modification of the trajectory equation. Alternately, the device can mechanically bring itself to level, using a method such as pistons or electro-mechanical actuators. Either of these options adds to the overall complexity of the design. Also, the impact of thrown regolith may damage the habitat's material. Lastly, any throwing mechanism needs calibration before use. Compensation or repair must be made for any alterations that may have occurred during transport to the lunar surface. Misalignment during transport can cause the device to routinely miss the habitat with the thrown regolith.

Several throwing mechanisms were considered. A mechanical arm, a crossbow or slingshot, and an impact mechanism are all methods to propel the regolith onto the habitat. There are several alternatives to power these throwing mechanisms. Options are chemical propellant, an electric motor, a permanent magnet and an electromagnet combination, an elastic band or spring, and a rail gun type of device. A detailed analysis of different throwing mechanisms is presented in a later section of the report.

A mechanical arm, as shown in Figure 7, is the first alternative considered for throwing. Devices such as skeet machines and tennis ball machines are proven arm-based methods to throw objects. Possible

disadvantages are that a rotational mechanism may cause stability problems due to the rotational inertia, and the rotational motion may increase any dispersion of the thrown regolith.

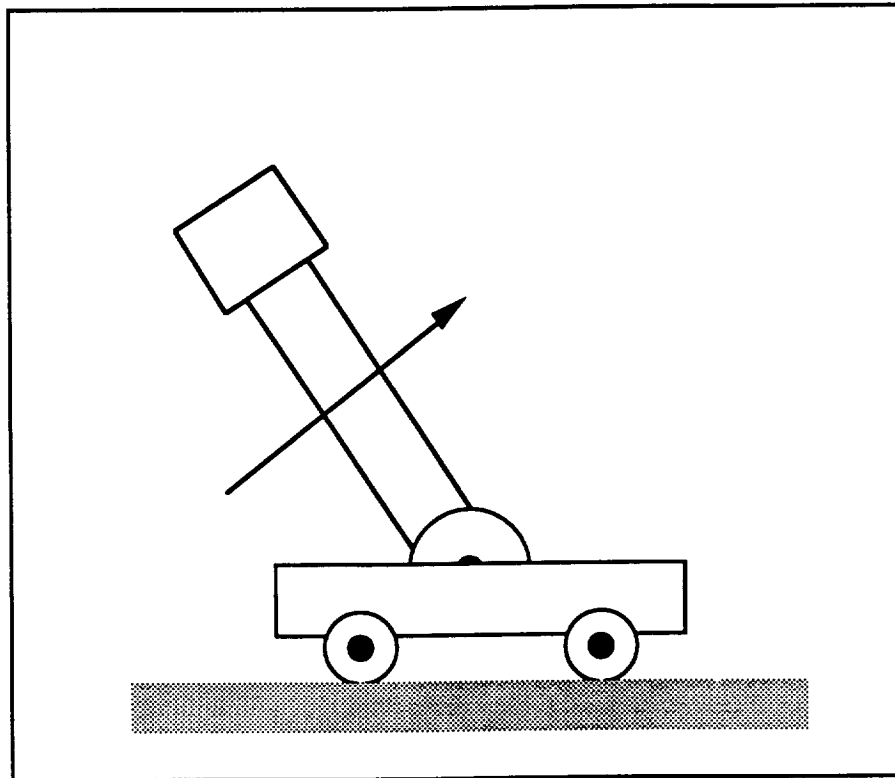

Figure 7. Mechanical throwing arm.

A crossbow or slingshot configuration, as shown in Figure 8, provides a linear path for throwing. The load chamber is moved backwards, energizing the powering device. The powering device is then released, propelling the load chamber forward. Linear motion removes the stability problems seen with a rotational mechanism. A possible problem with this configuration is the guide track that is needed. Such a track is susceptible to fouling by lunar dust.

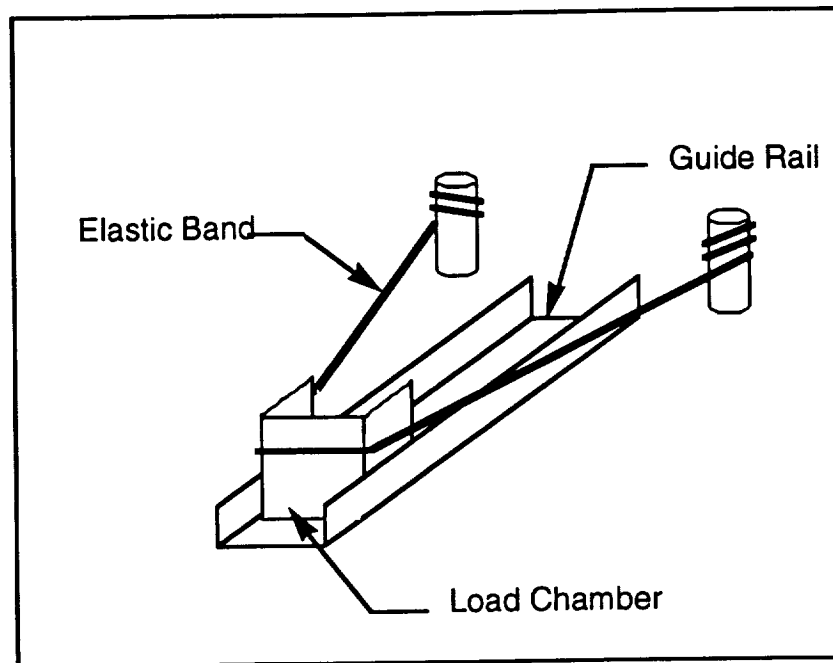

Figure 8. Crossbow or slingshot configuration.

An impact mechanism can also be used to impart the needed kinetic energy to the regolith. As shown in Figure 9, the regolith is loaded onto a thrust plate. The thrust plate is then impacted by a sledge to propel the regolith. However, a sledge large enough to achieve the desired velocity and range may be too massive to be feasible. A propellant may be needed to supply the needed energy. A propellant-based option will operate similarly to a shotgun. A disadvantage is that the propellant will have to be supplied from Earth or manufactured on the lunar surface. Either of these possibilities increases the costs of the device. The propellant also has to be reloaded after every launch of regolith.

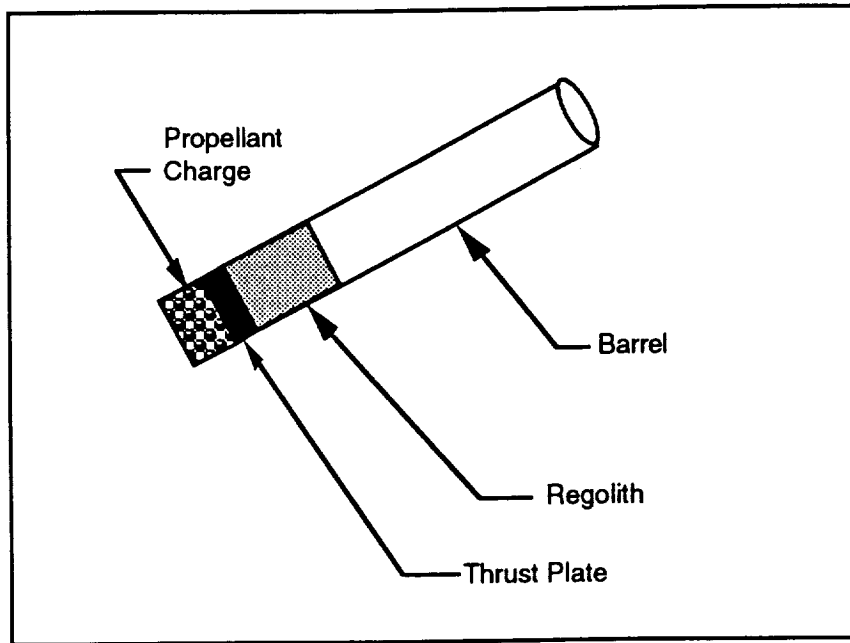

Figure 9. Impact mechanism.

Any of these throwing options need to be powered to propel the regolith to the habitat. As discussed earlier, chemical propellant is one method to propel the lunar regolith. Throwing regolith can also be done by an electric motor. Another alternative is a permanent magnet and an electromagnet combination, as seen in Figure 10. When the electromagnet is uncharged, the arm is in a rest position. The magnetic dipoles of the two magnets are initially oriented perpendicular to each other. Then, when the electromagnet is energized, the two magnet poles move to align themselves, causing the arm to rotate and propel the regolith. An advantage to this configuration is that the rotating surfaces, the magnets, are supported by the magnetic field. The two magnets do not touch so no lubricant is needed. However, the energy needed to generate the magnetic field may be prohibitive.

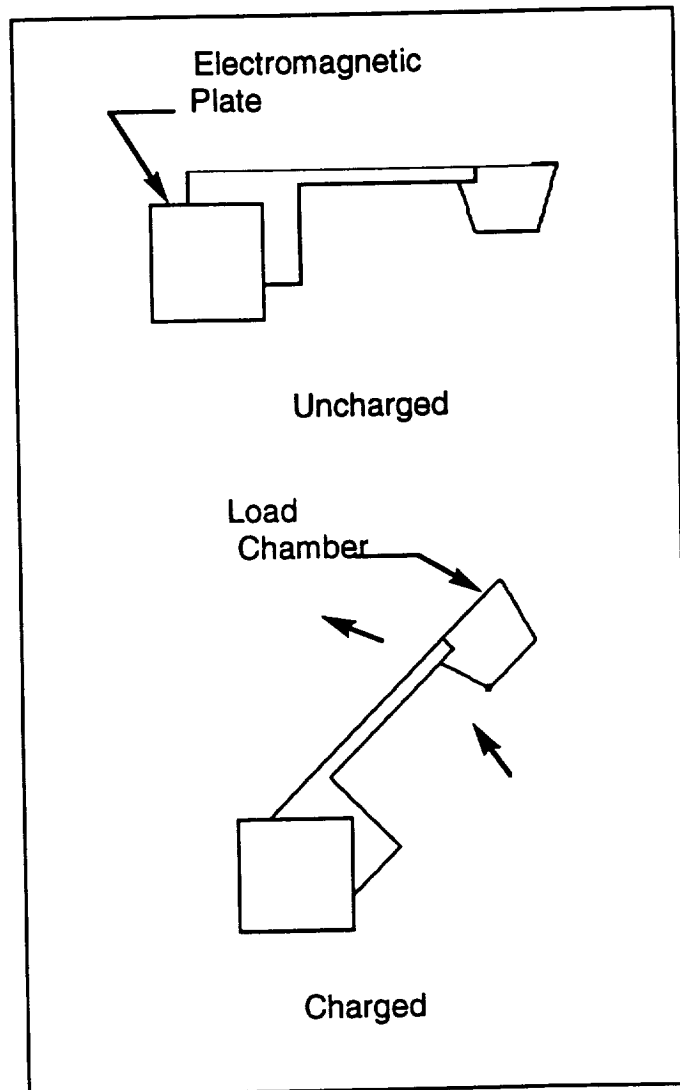

Figure 10. Magnetically-driven arm.

An elastic band or a spring are other alternatives to power the throwing device. The elastic band is energized by elongation whereas the spring is energized by compression. These two alternatives have the advantage of being able to be loaded slowly. By slowly energizing the devices, the power requirements can be lowered. The drawback of an

elastic band is the lack of durability. Elastomers have poor characteristics in the lunar environment. The high temperature fluctuations and the radiation on the lunar surface can greatly reduce the life of an elastomer.

The last alternative is the rail gun type of device (see Figure 11). By placing the device in a magnetic field, the regolith load chamber can be propelled forward, according to Faraday's Law of Induction. An advantage of this alternative is that the magnetic field can also be used to support the load chamber, by magnetic levitation. This levitation removes the need for lubrication. However, the magnetic field needed may be excessive. Any magnetic field generated may also affect electronics on the lunar device.

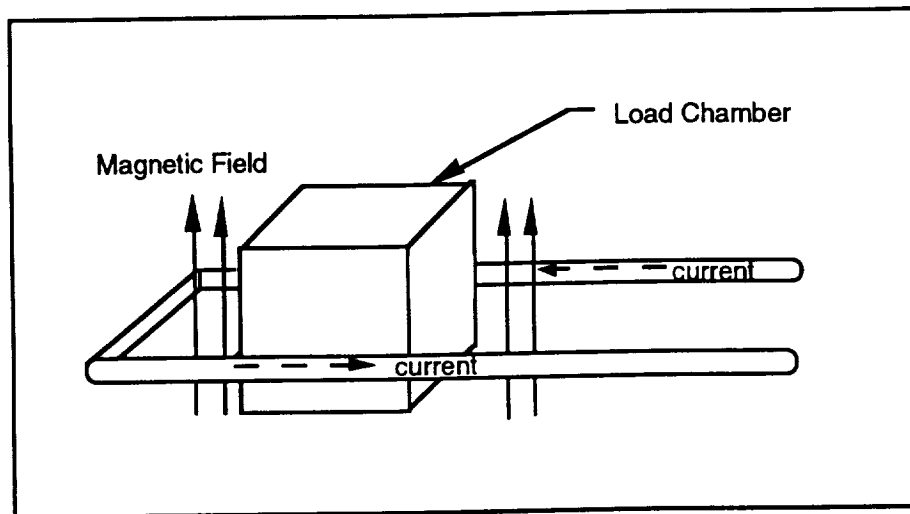

Figure 11. Railgun throwing mechanism

3.3 Collection of Regolith

Before the device can place any regolith on the habitat, the regolith has to be gathered. Several methods were considered for the collection of

regolith. These methods are a bulldozer, a back hoe, a posthole digger, a broom, and a "Ferris wheel" arrangement. A scarifier and an auger can be used to loosen the surface regolith. This initial preparation can lower the power needed for regolith collection. Methods such as a bulldozer, back hoe, and a posthole digger are proven Earth-based methods for the collection and movement of soil. These various mechanisms are shown in Figure 12. These tools can be modified or adapted for use on the lunar surface.

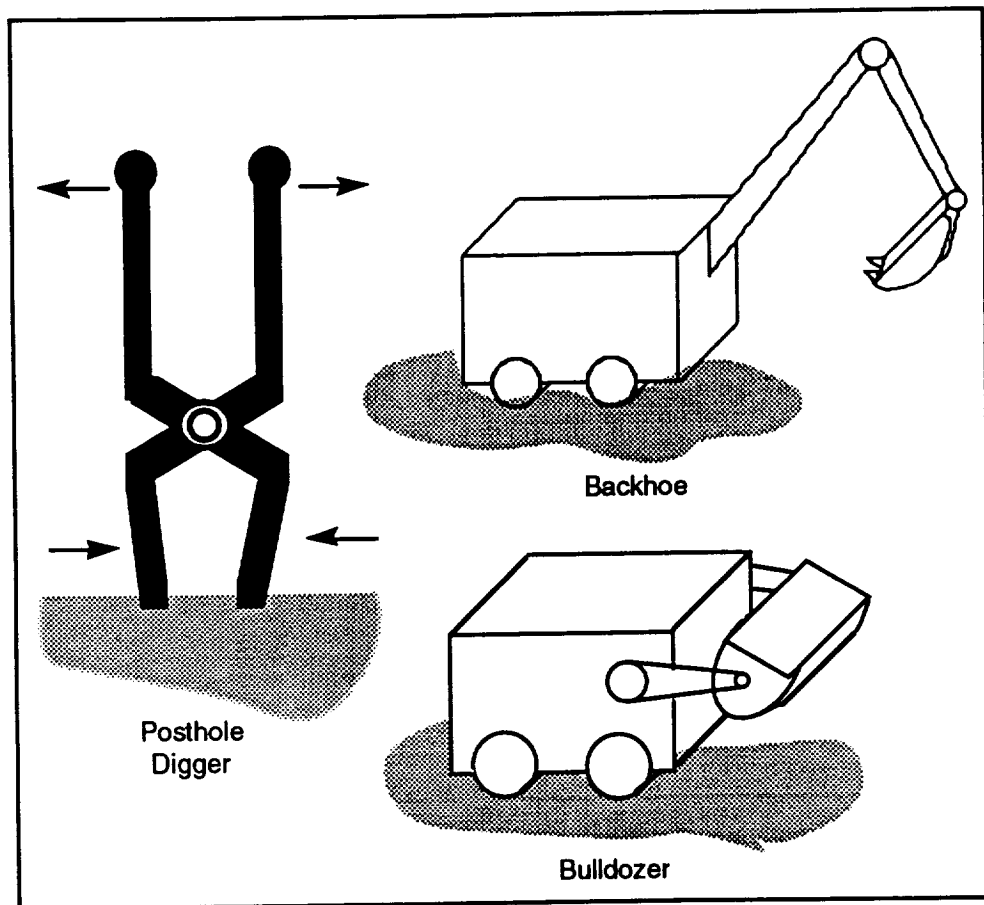

Figure 12. Standard Earth-moving equipment.

A modification of the bulldozer concept is a simple ramp angling into the lunar surface. As seen in Figure 13, the forward motion of the device causes regolith to go up and over the ramp into a collection bin. The feasibility of a ramp may be limited by the available traction on the lunar surface. This alternative is examined in greater detail in Appendix J.

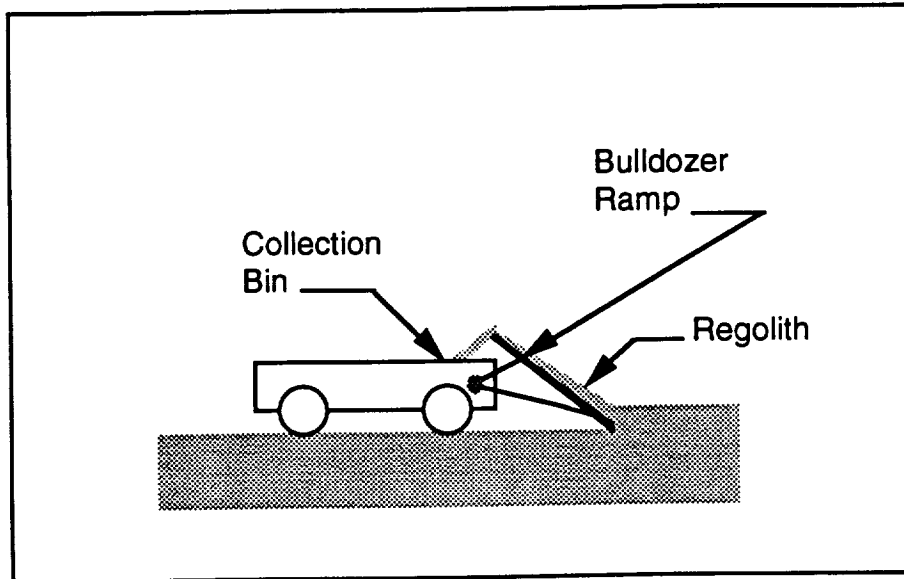

Figure 13. Bulldozer modification.

A sweeping mechanism, shown in Figure 14, can also be used for the collection of regolith. The brush rotates, sweeping regolith into a receptacle. An advantage of a sweeper is that small rocks may automatically be filtered out. The impact of small rocks on the lunar habitat during regolith placement may damage the habitat. A disadvantage of sweeping is that it will agitate the lunar surface, possibly causing dust clouds. Lunar dust will adhere to any device, accelerating mechanical wear.

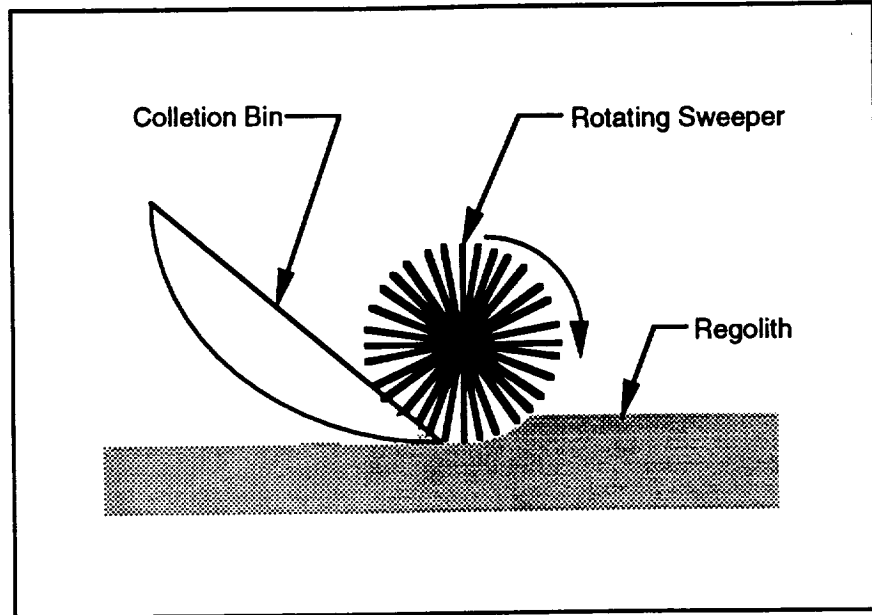

Figure 14. Sweeping mechanism.

A "Ferris wheel" arrangement, shown in Figure 15, is another rotational mechanism for regolith collection. The "Ferris wheel" rotates, scooping up regolith which is then dropped into a collection bin. Though having moving parts, the Ferris wheel might double as a means for propelling the entire device. This dual function can save mass on the final design.

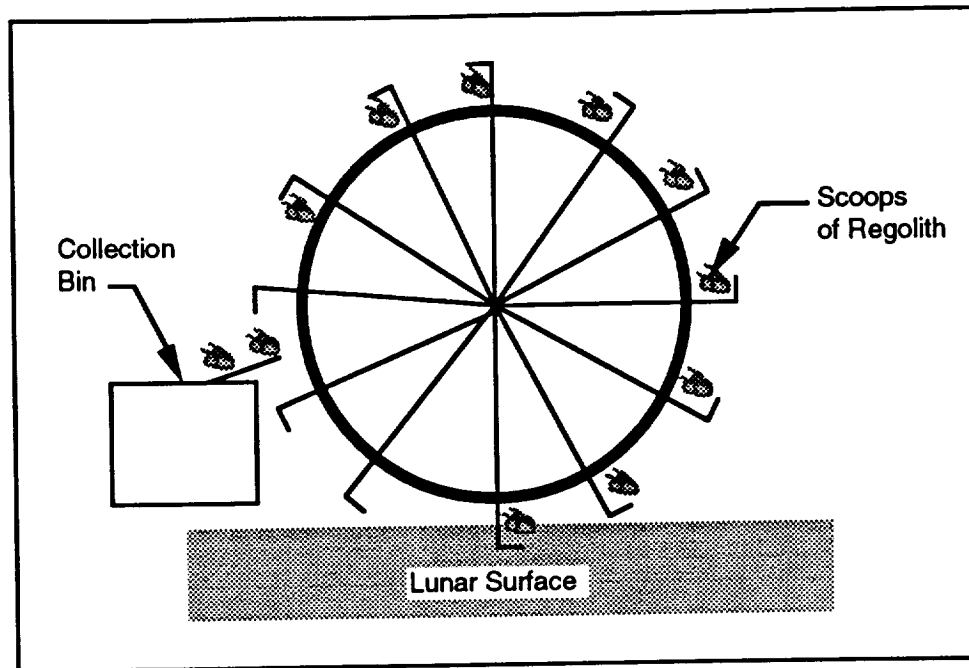

Figure 15. Ferris wheel arrangement for gathering of regolith.

Loosening the regolith prior to being collected may make the gathering of regolith easier and less power intensive. Therefore, the following alternatives need to be investigated further. A scarifier, shown in Figure 16, is a toothed platform that is dragged across the lunar surface. The scarifier teeth rake out large rocks and brake up the regolith, making it easier to collect. Another device that can be used to loosen the regolith is an auger, also shown in Figure 16. The blades of an auger rotate, breaking up the surface regolith. Either of these two devices can be coupled with the collection tools to reduce the power needed for the collection of the regolith.

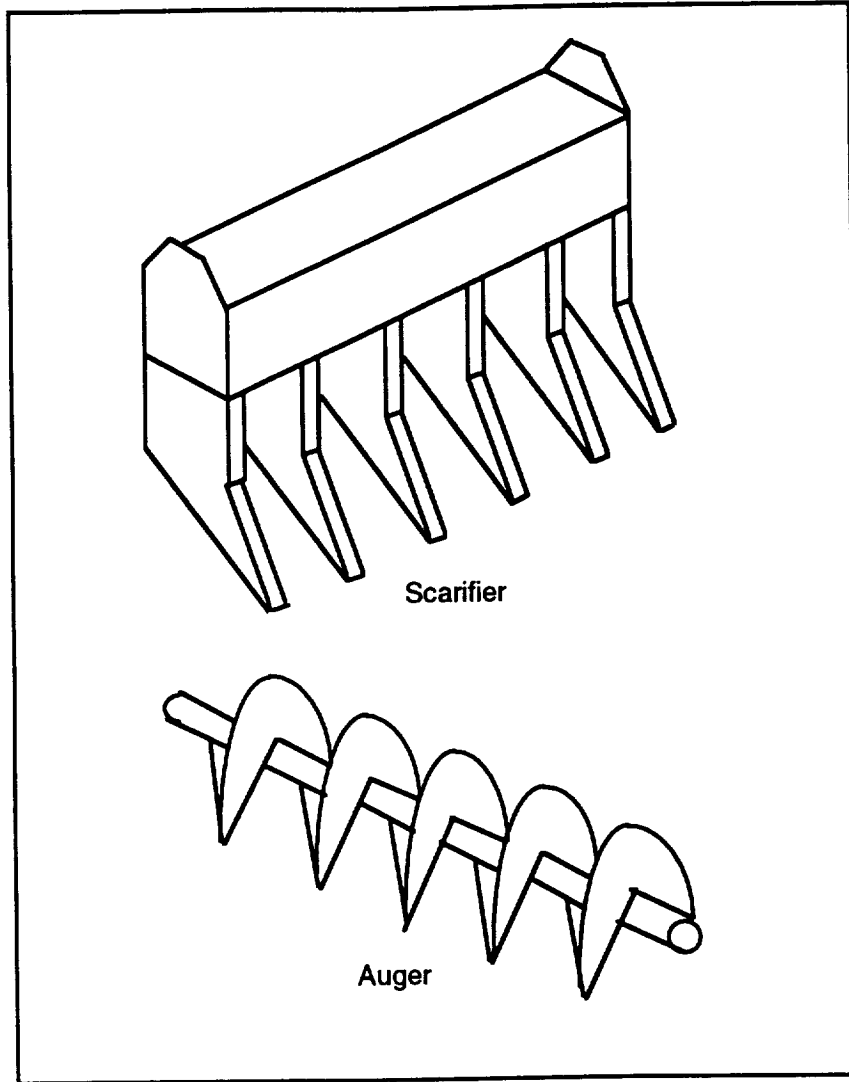

Figure 16. Scarifier and auger mechanisms.

3.4 Vehicle Mobility and Locomotion

The device needs to be able to safely traverse the lunar surface. Several driving mechanisms were considered for the vehicle's locomotion. Traditional methods, such as wheels, tracks, and half-tracks and more exotic methods, such as walking or hopping were considered. There is a trade between low complexity, low maintenance alternatives, such as wheels, and high complexity, high maintenance alternatives, such as walking. A high complexity, high maintenance device is often better suited to climbing slopes up to 45 degrees and dealing with obstacles such as large rocks and chasms [16]. Other components of a driving mechanism, such as frame, suspension, drive train, and steering are items which need to be addressed in the final design of the device. These items will not be covered in this project.

Wheels, the traditional solution, have been used on previous lunar missions and were proven successful. Four types of wheel configurations were considered for the device's drive mechanism. The wheel configurations are wire mesh wheels, inflatable tires, flexing metal wheels, and hemispherical wheels. The various wheel geometries are shown in Figure 17.

Wire mesh wheels, like the ones used on the Apollo lunar rover, are light weight and durable. However, these wheels cause problems by stirring up lunar dust and have a limited weight bearing capacity [17].

Inflatable tires, like the ones used on the Apollo equipment cart, are light weight, provide good suspension, and good traction on smooth

surfaces. A problem is the selection of wheel material. Elastomers have poor characteristics in the lunar environment.

Flexing metal wheels consist of a concentric hub and tread joined with cylindrical springs. These wheels are light weight, have good weight capacity, and provide a passive suspension [18]. The use of metal increases the wheels' durability.

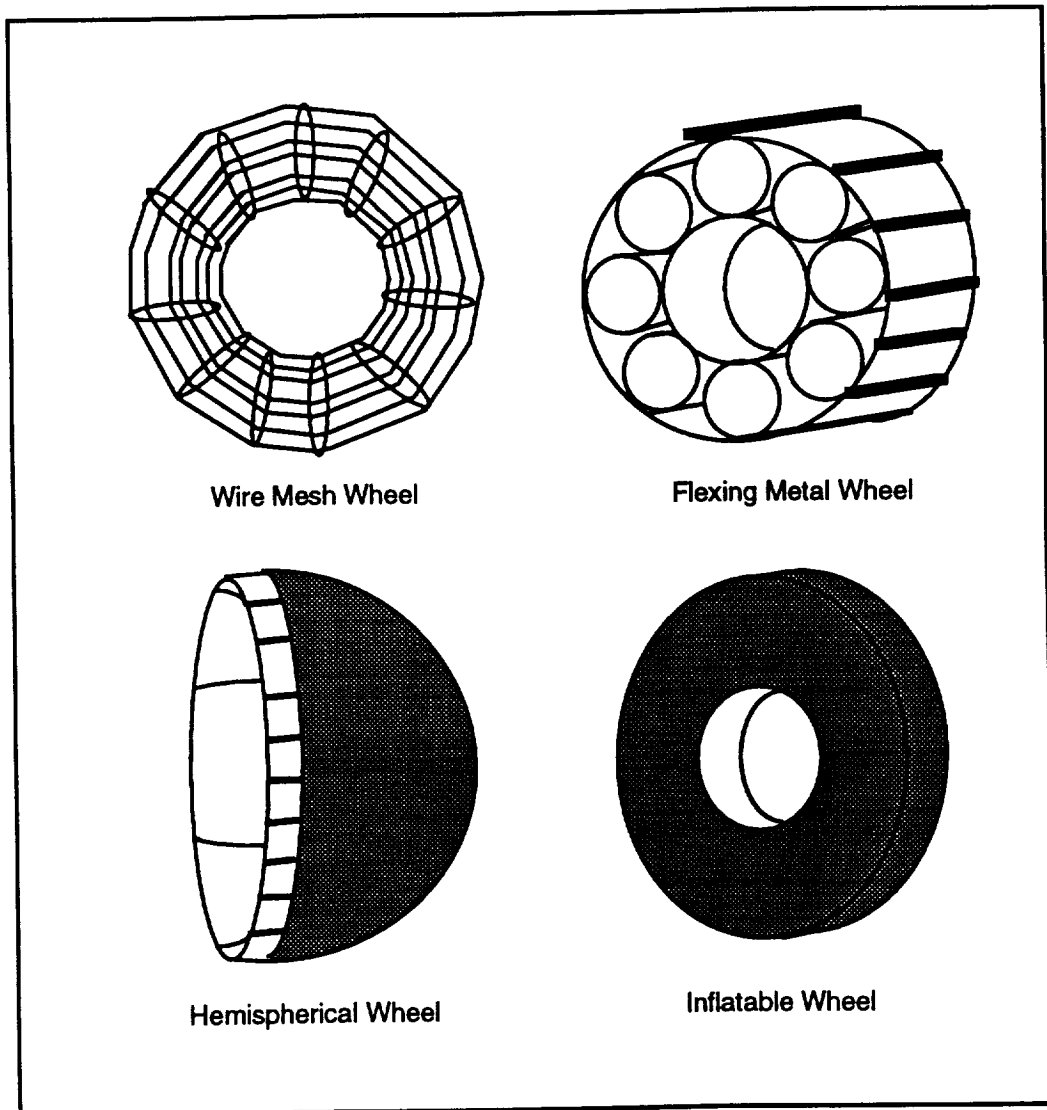

Figure 17. Wheel geometries.

Hemispherical wheels are the fourth wheel alternative. Fiberglass cone wheels were used in Vietnam and lasted 25 800 km (16 000 miles) before failure [19]. Hemispherical wheels are an improved alternative to cone wheels. Cone wheels have high stress concentrations at the point where the rim joins the body. The body of a hemispherical wheel is curved to eliminate these stress concentration points [20]. These body modifications provide the hemispherical wheel with an increased load bearing capability. Also the treads on the rim of the wheel provide for greater traction. Hemispherical wheels are also very durable [21].

Another item to be considered is the number of wheels to be used. The possible number of wheels ranges between two and six. Two-wheeled and three-wheeled vehicles have problems with stability. Four-wheeled and six-wheeled vehicles provide a more stable platform. Four and six wheels have also proven successful for surface transportation in both terrestrial and lunar applications. Six wheels require more power but offer greater stability and an increased ability to handle difficult terrain. In addition, with six wheels, it is possible to sustain the failure of one wheel and still maneuver.

Tracks, or treads, are another option for lunar mobility. Tracks, such as those of a military tank, have large surfaces in contact with the ground which produce more traction than wheels and provide exceptional handling on rough terrain. With tracks, shown in Figure 18, a vehicle effectively lays its own road wherever it goes. Tracks are the most energy-efficient option on very soft ground, such as the powdery lunar surface [22]. However, the number of moving parts for tracks is much greater than that

for wheels. The increase in moving parts increases the likelihood of mechanical failure and lowers the reliability of the system. In addition, tracks are more vulnerable than wheels to damage from the lunar surface. Small rocks, as well as an accumulation of lunar soil, can cause the tracks to stall or derail. This failure will render the vehicle completely immobile until repairs are made.

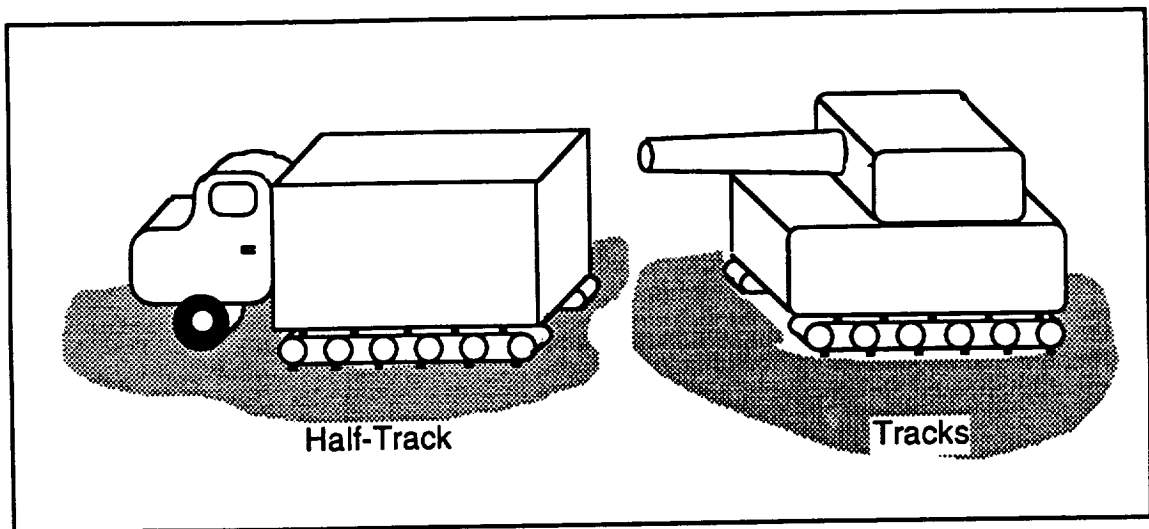

Figure 18. Examples of half-tracks and tracks.

A half-track, also shown in Figure 18, consists of two front wheels for steering and two rear treads for propulsion. This alternative combines the advantages of both wheels and tracks and provides excellent off-road capability. The front wheels make the device easier to maneuver, and the tracks give the drive mechanism better traction and handling of rough

terrain. However, a half-track still has the problems with the possible jamming and derailing of the tracks.

More exotic methods of vehicle mobility, such as walking or hopping, were also considered. A walking, or legged, device and a hopping mechanism both increase the ability to handle difficult terrain. A walking mechanism can stride over obstacles, while a hopper can hop over the obstacles. A major drawback is the immense complexity associated with these mechanisms. Controlling legs or planning a hop makes these options extremely complex.

3.5 Vehicle Navigation and Location

During operation on the lunar surface, the position of the device with respect to the habitat needs to be known. Determining the position of the device is important for a number of reasons. To deposit the regolith on the habitat, the location of the device with respect to the habitat needs to be determined. The position of the device may also be important to prevent it from repeatedly removing regolith from the same area of the lunar surface.

There are two main categories for navigation and location: absolute positioning and relative positioning. Absolute positioning uses external reference systems to estimate the position of the device with respect to its surroundings and is generally based on a fixed coordinate system. Absolute positioning systems generally use line of sight (LOS) measurements to determine distances between objects. Limited range is a shortcoming of LOS measurement systems. If the lunar surface is assumed flat, without obstructions, two devices, 2 m in height, would have a LOS of approximately 5 km. [23]. Another disadvantage of an absolute system is the need for additional equipment external from the lunar device.

Relative positioning uses internal reference systems and is characterized by self-contained mechanisms; methods that are contained entirely in the lunar device. A relative positioning system measures where the device is, compared to where it once was. A problem with relative positioning is that the cumulative error from position readings will result in drift of the device. Periodic calibration, with an absolute system, is needed to overcome this drift. In addition, preliminary calibration of any

navigation system will need to be performed before the positioning system can be used.

3.5.1 Absolute Positioning

There are several options for an absolute positioning or navigation scheme. These options include a satellite system, laser or electro-optical triangulation, radar, or a beacon network.

An expensive, yet feasible, alternative is a lunar positioning satellite (LPS) system. Such a satellite system is very similar to the satellite systems used on the Earth. An important measure of the quality of the navigation and location system is how accurately the system can determine the relative locations of the habitat and the device. To provide a location accuracy of less than one meter, the LPS uses a minimum of four satellites [24]. Three satellites provide the location while the fourth provides a temporal, or time, positioning. A problem with this system is the time needed for the actual location process.

Triangulation is another option for an absolute navigation system. Triangulation can be accomplished with lasers or precision cameras. With either method the habitat is referenced as the origin of a grid system. Distances are then measured from the habitat to several prominent terrain features. Prominent terrain features include hills, boulders, cliffs, the habitat or other clearly identifiable, fixed landmarks.

The location of the device is determined by multiple point resection calculations. These calculations require the measurement only of central angles from the location of the device with respect to the origin, as shown in Figure 19. These angles are measured with either a laser or a TV camera

tracking assembly. Also, the azimuthal angles, as shown in Figure 20, are measured to determine the heading of the unit with respect to terrain features. Currently, with a high-powered laser (50 to 100 W), an accuracy of six meters over a 10 km range is possible. NASA projects a one meter accuracy over a 100 km range to be available by the mid-1990s [25]. When using precision cameras instead of lasers, an accuracy on the order of meters is expected. However, with cameras the fragile quality of the optics presents a problem. The lunar dust can cover any optics left exposed preventing the cameras from tracking accurately. The lunar dust is adhesional and is difficult to remove without damaging the lens.

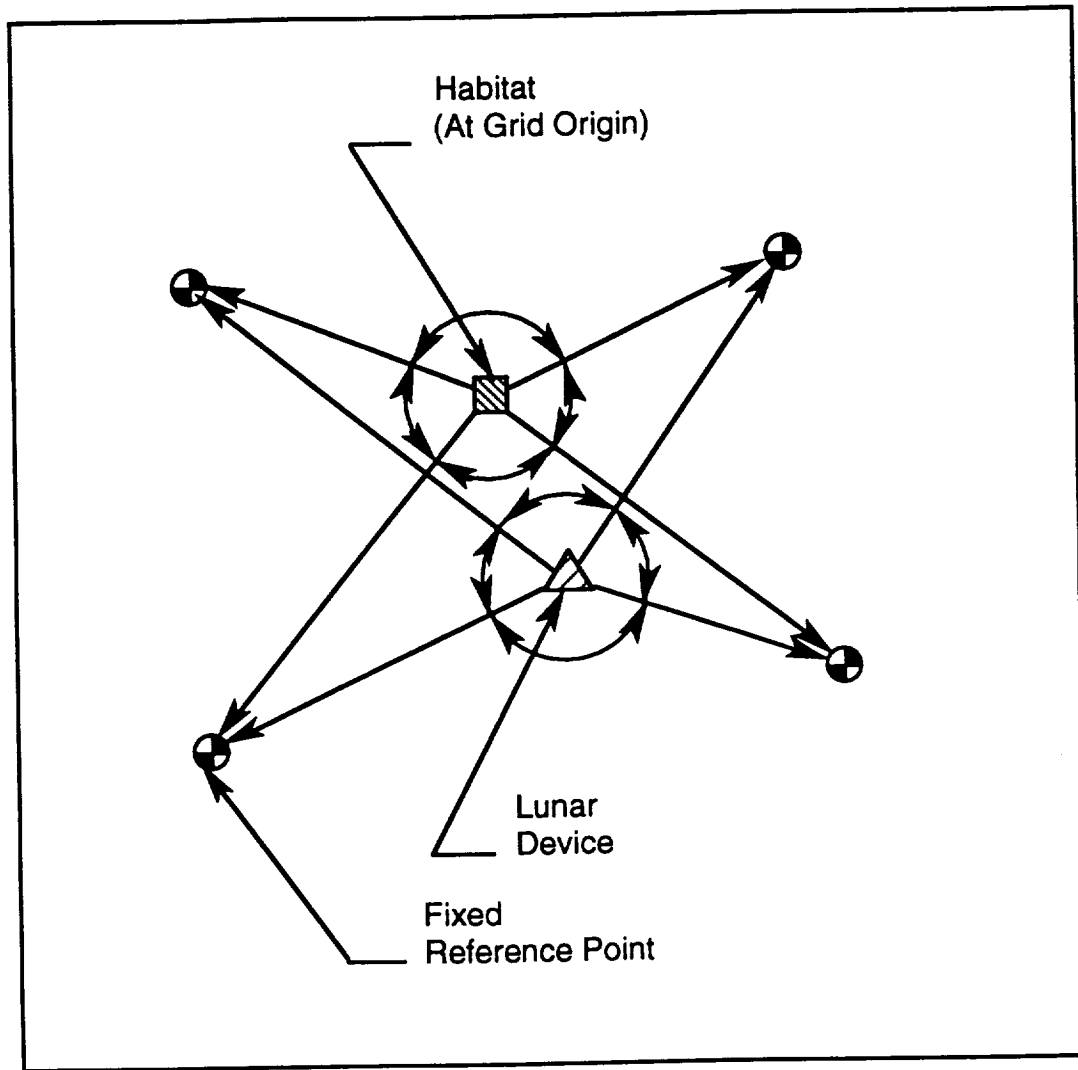

Figure 19. Angle measurements for multiple point resection calculations

[26].

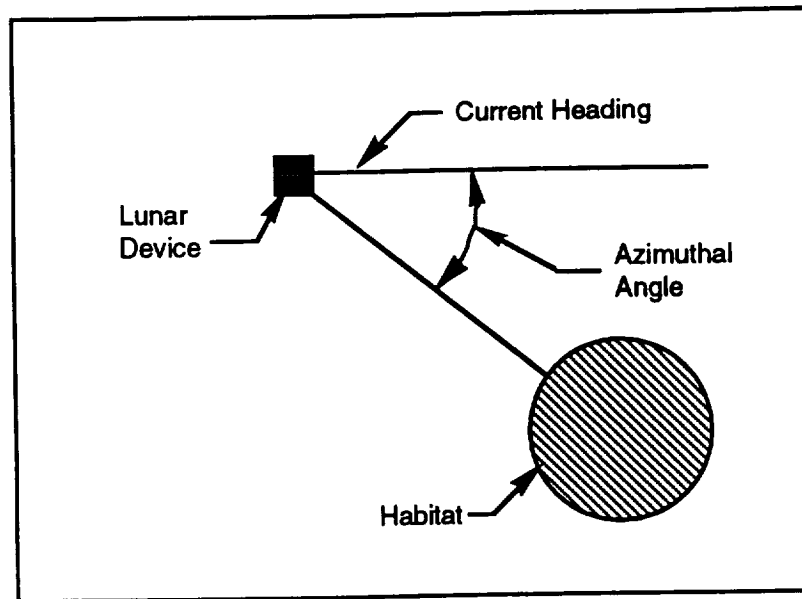

Figure 20. Azimuthal angle.

Radar is another possibility for navigation and location. Using pulsed, low frequency radio waves, the distance between the habitat and the device can be determined. Low frequency waves operate on the time delay between signal transmission and echo reception. The relative location of the device is determined with an accuracy on the order of meters [27]. A problem with low frequency waves is signal noise generated from ground interference. This interference creates false images in the system preventing the accurate location of important objects. This problem can be avoided using high frequency radar, which operates on the Doppler principle. However, the Doppler principle is better suited to measuring velocities of objects, not distances. A problem with either type of radar is that a scanning antenna is needed. This scanning can be done either mechanically, with a rotating antenna, or electronically, with a phase-shifting signal. A drawback of the mechanical option is that it requires

moving parts that can experience problems with the lunar dust. In addition, moving parts are not as reliable as solid-state options. A disadvantage of the electronic antenna is that it is more massive than the mechanical antenna. In addition, a phase-shifting antenna can be over ten times more expensive than a purely mechanical antenna [28].

The last method of absolute navigation presented is a network of beacons. A network of beacons, as shown in Figure 21, with the habitat as a central reference point, can be used to generate a grid to locate the unit. The beacons are referenced to the position of the habitat, each beacon has means for producing a coded signal which uniquely identifies that beacon. The position of the device is determined from the beacon that it is near. A major problem with this option is that the beacons need to be transported to the lunar surface from the Earth. This extra mass will increase the expense of transporting the device from Earth. Another disadvantage of this system is that the beacons need to be set in position before device deployment. Additional programming needs to be included with the device so the position of the unit is obtainable relative to each beacon.

A simple method to estimate position with a beacon array is using a proximity detection system. This type of system calibrates position from a single reference point and uses a single beacon placed on top of the habitat providing a continuous signal. This signal is detected by sensors placed on the device. An advantage of this alternative is its simplicity, low power requirement, and that no extra mass needs to be transported to the Moon. A disadvantage of this system is that if the single beacon fails or is covered by lunar dust before the habitat is covered, the device will not be able to finish its task.

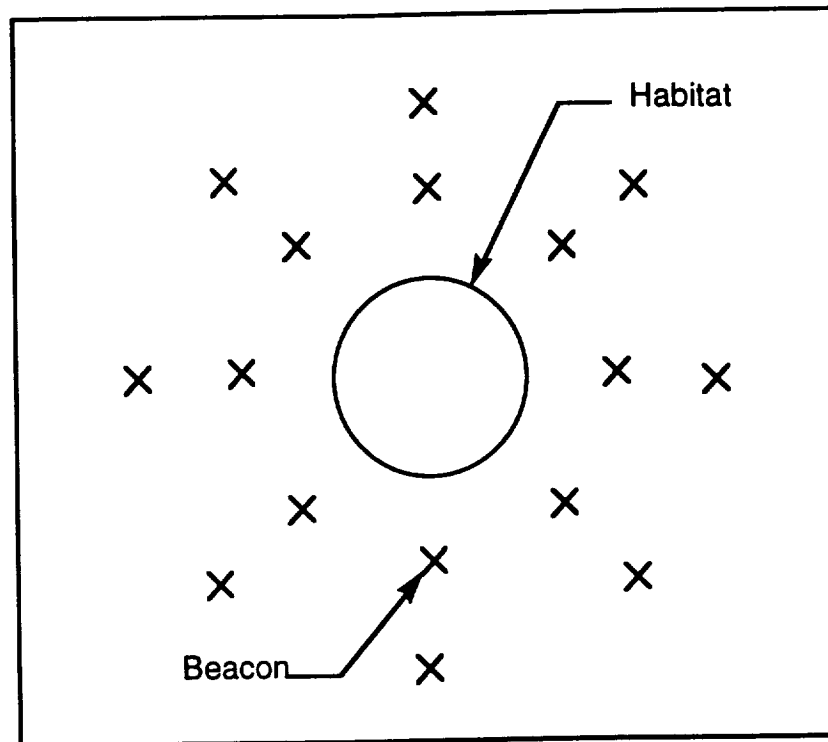

Figure 21. Beacon network configuration.

3.5.2 Relative Positioning

The second class of navigation alternatives is relative navigation systems. A relative system is calibrated to a known reference point. Then the device's position is determined by measurements relative to the calibration point. Possible alternatives are an inertial navigation system (INS), an axle-rotation counter, and terrain scene or feature matching. Relative positioning systems accumulate error as the device moves. With many of these methods, periodic global position updates are needed to maintain accurate position information. Such updates can come from any of the absolute methods mentioned earlier.

Current INS technology has positioning errors of five to ten meters for 10 km of travel. The power for such systems is on the order of 100 W. Projected INS development provides for errors of one or two meters by 1998, with a power reduction of 25 percent [29]. Inertial reference systems, such as gyroscopes, are quite expensive and relatively delicate.

Dead-reckoning is another possible method for relative positioning. An axle-rotation counter can determine the distance traveled by counting the number of axle rotations of the device's drive mechanism. However, a problem exists if the device is stationary and wheel spin occurs. Wheel spin will make the axle-rotation counter register a false movement thus reducing the accuracy of the positioning system. Dead reckoning is a low cost, self contained method for navigation and control. method is memory dependent and if distances traveled are large it has been found to be inaccurate. Dead reckoning was the method used by the Apollo lunar rover vehicle.

Another possible method of relative navigation is terrain scene or feature matching. This system requires a complete map of the area of operation and accurate optical sensors. The optical sensors match the surroundings with the information on the map to determine the position of the device. A disadvantage of a mapping system is that it requires memory capabilities for map storage and future recall. Memory will increase the expense and complexity of the device. Also, detailed knowledge of the terrain is needed to generate a map before the terrain scene or feature matching system is feasible.

With any of these methods, calibration of the location of the device, or devices, is needed before the lunar design can be deployed. Calibration will

correct for any misalignment that may have occurred during transport from Earth. Calibration can be a human-driven procedure, or some form of self-diagnostic check.

3.6 Determination of Finish Point

When placement of the dirt upon the habitat is taking place, steps must be taken to determine the stopping point for dirt placement. Enough regolith is needed on the habitat to provide the required level of radiation protection. However, too much regolith on the habitat may cause the habitat to collapse. Several methods for the determination of a finish point were considered. These methods are indicators on poles, a mechanical probe, sonar, and a rate or integral method.

As seen in Figure 22, indicators can be placed on poles either around the habitat or on the habitat itself. Since regolith's angle of repose is known, the profile of the final placed regolith was determined. The length of the poles will be equal to the needed thickness of regolith at a given point. Once the indicator is covered, the lunar device can no longer pick up the signal and will cease to place regolith on the habitat. Light emitting diodes (LEDs) can be used with optical sensors. Beacons can be used with radar sensors. Mirrors can be used with either lasers or optics. While requiring additional mass to be transported to the lunar surface, indicators on poles provide a relatively simple way to determine a stopping point. Placing the indicator poles around the habitat does not require any modifications to the actual habitat. However, by attaching the poles to the

habitat, the poles may be automatically put into place when the habitat is inflated. These options are also low power and have no moving parts. Another advantage of these options is that they can be used in a targeting system. A single pole placed on top of the habitat will be the simplest and most inexpensive way to use poles to detect the finishing point.

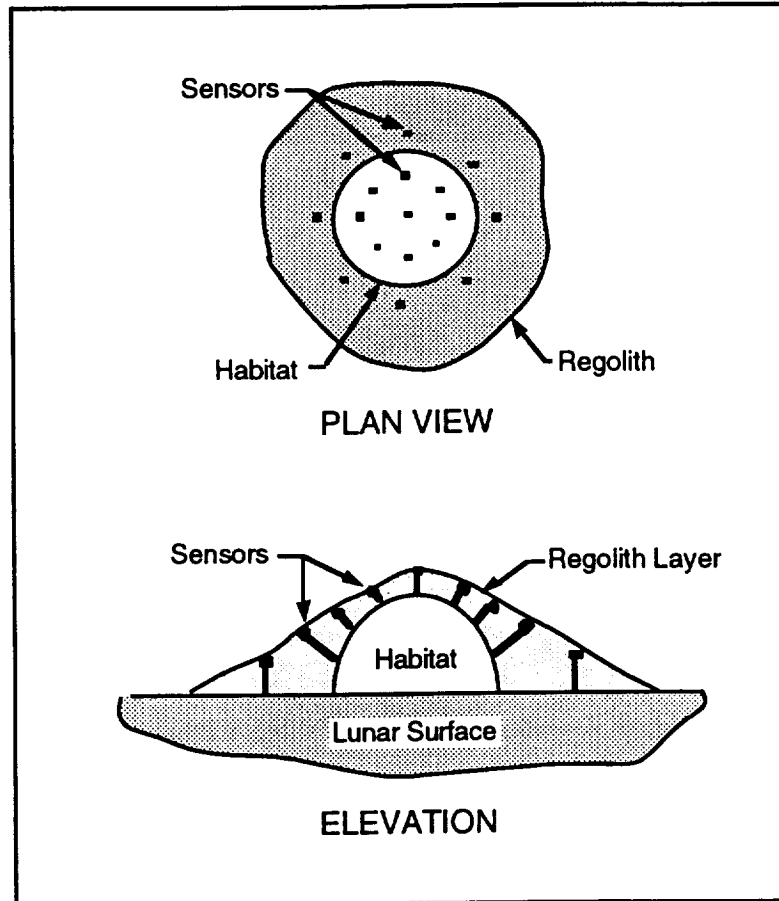

Figure 22. Configuration of sensors on poles.

A mechanical probe can also be used to test the regolith depth. The lunar device can insert a pole into the regolith and measure the depth of penetration to the habitat surface. The stopping point can be determined by

the measurement of this depth. A mechanical probe is a simple and low power method. However, it requires the lunar device to be near the habitat for testing and to know the exact location on the habitat where the depth reading is being obtained.

A sonar probe is another alternate solution for determining the finish point. The device can transmit a sonar wave through the regolith covering the habitat. By measuring the time for the echo to return, the thickness of regolith can be determined. Using a sonar probe may be a high power, expensive, and complex method to accomplish this task.

A rate-based option for determining the stopping point is another alternative. Three rate-based methods were considered. The first method consists of allowing the device to run for a predetermined period of time. After this predetermined time period the habitat will be covered. The time period necessary to completely cover the habitat can be determined by knowing the rate of dirt movement and the volume of dirt needed to cover the habitat. A safety factor will be needed to account for the regolith misplaced during the operation. The second method consists of adding up the total amount of regolith moved and comparing this value to the actual volume of regolith needed. This comparison can be done on a mass, weight, or volume basis. Lastly, by knowing the volume of regolith needed, a maximum depth of digging can be determined. This maximum depth will have a characteristic regolith density. Once this density is reached, the device will know to stop digging in this area and proceed to another site. A disadvantage of these three methods is having to account for errors in regolith placement. All of the regolith, either thrown or dumped, will not

fall onto the habitat. Therefore, a safety factor is needed to ensure that the habitat is covered with the minimum regolith thickness.

Another alternative for determining the finish point is locating a weight sensing device in a specific point in the habitat. When the required weight of regolith is reached, a signal will be sent to the device for it to stop the placement of regolith.

3.7 Powering of Unit

To perform all the necessary functions and to be an independent autonomous device, the unit must contain a power system. The power system of the device needs to supply the electrical power needed for peak power operations and adequate energy storage for the operational period on the lunar surface. Large temperature ranges, no natural fuel sources, and mass restrictions make finding a suitable power source difficult for lunar applications. There are currently several alternatives available that have characteristics that enable them to be employed in lunar applications. More power sources to be used on the Moon are currently under development and should be available before the lunar outpost is implemented.

To choose a power system, a steady average power demand is assumed, with occasional higher peak power demands. Peak demands are caused by such things as the ascent of an incline or the placement of regolith on a habitat. Throwing the regolith requires sufficient power to launch the regolith at a large enough velocity to reach the top of the habitat.

Carrying the regolith to the top of the habitat requires adequate power to lift the regolith from the ground level to the top of the habitat. Several options exist for the actual power generation, such as solar systems, chemical systems, and nuclear systems. Other items to address are the transformation of power to a usable form and the recharging of the units.

3.7.1 Power Generation

A possible solution for power generation is solar cells. A bank of solar cells directly converts the energy of the sun to electrical energy. Solar cells, such as photovoltaic cells, offer a low mass alternative for power generation, however, they have several weaknesses. The harsh lunar environment can degrade the performance of a solar cell by as much as 25 percent in seven to ten years of operation [30]. Their performance is degraded as lunar dust and micrometeorites cover and scratch the surface of the solar cell. Also, space radiation can turn the surface of the solar cell opaque, lowering its effectiveness. With a typical efficiency of ten percent for solar radiation conversion, even a modest power requirement creates a need for a large solar array for a mobile device [31]. Additionally, if the design is to operate during the lunar night, a back-up power supply is needed.

A second alternative to provide power to the unit is chemical power systems. Chemical systems can take the form of a battery or of a regenerative fuel cell. Batteries make a poor primary power supply for several reasons. Batteries need complete replacement upon failure. Replacing batteries on the Moon will be costly and difficult. Batteries are

also a mass intensive power option. Current state of the art batteries have energy densities on the order of 25 to 40 W*hr/kg. Projected development provides for energy densities on the order of 100 W*hr/kg in the mid-1990s [32]. Also, the current density, or depth of discharge, needs to be minimized for a long battery life. This long life requirement creates a need for more massive battery banks. A better use for batteries is as a power back-up, especially during peak power loads.

An option similar to a battery is the fuel cell. A fuel cell is a cell that continuously changes the chemical energy of a fuel and oxidant to electrical energy. The main difference between batteries and fuel cells is that fuel cells have their fuel and oxidizer continuously supplied from an external source. NASA is currently researching regenerative fuel cells (RFC). The process description of an RFC is shown in Figure 23. Water is a by-product of an RFC. An advantage of using an RFC is that the water can be used for other applications. In addition to the fuel cell, an RFC includes an electrolyzer. During the day, the RFC system uses an externally powered electrolysis subsystem to produce hydrogen and oxygen from the water. A potential source for this external power subsystem is a solar array. At night, the RFC generates power by reacting the hydrogen and oxygen to form water [33]. The oxygen generated can also be used for life support. RFCs are predicted to be operational in the mid-1990s. A disadvantage of RFCs is that more research is required to address issues such as maintenance and reliability.

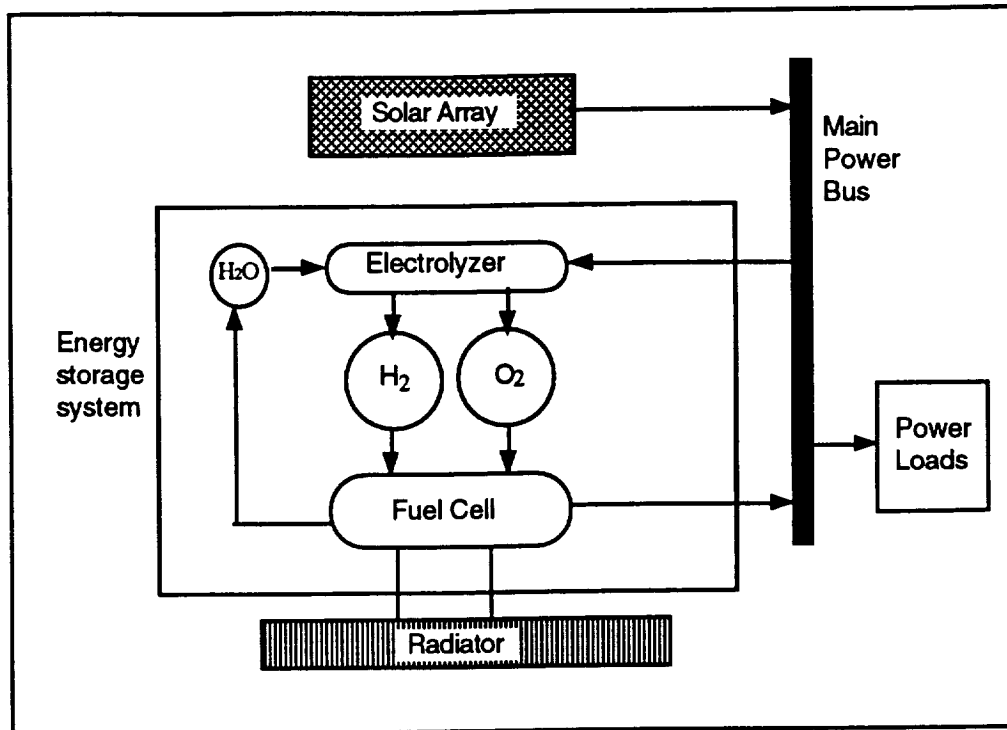

Figure 23. Regenerative fuel cell process description [34].

Another potential power source is a nuclear system. There are nuclear systems both under development and currently available that can be used to power the lunar device. One system under development is a dynamic isotope power system (DIPS) [35]. DIPS may operate on a Brayton, Sterling, or other energy cycle. A currently available system is the radioisotope thermoelectric generator (RTG). An RTG provides power by releasing thermal energy from the decay of radioisotopes. A static thermoelectric conversion system is used to convert this thermal energy into electrical energy [36]. Currently, RTG systems use a General Purpose Heat Source (GPHS). A GPHS module consists of plutonium-238 pellets in a graphite shell. The graphite shell is used to meet aerospace nuclear safety standards. A GPHS-RTG provides power in the range of 5.4 W/kg with a

thermoelectric conversion efficiency of 6.5 percent. General Electric is currently developing a modular RTG (MOD-RTG) system for the Department of Energy. A MOD-RTG can provide from 19 to 342 W depending on the number of GPHS modules used. A MOD-RTG has a projected performance of 8.4 W/kg and a conversion efficiency of 7.6 percent [37].

3.7.2 Power Conversion

The power supply can either be connected directly to the electrical system or first converted using a dynamic method of power conversion. Direct power conversion can be used with photovoltaic or thermoelectric power sources. Other types of power sources require dynamic methods of power conversion to produce electrical energy. Dynamic methods are Stirling, Brayton, or other cycles. A disadvantage of dynamic systems is that they rely on moving parts for power conversion [38]. Moving parts can cause many problems, due to dust contamination and unreliability.

3.7.3 Recharging of Unit

If the device is to have an extended life, powering is a critical issue. The power systems considered may not have enough energy storage to complete the assignment without replacement or recharging. The operational life of the device can be extended by increasing the size of the power storage units. However, increasing power storage increases the mass of the unit, thereby increasing the costs to put it on the Moon. An alternate method is to periodically recharge the device, or provide it with a

new power storage unit, such as a new fuel cell. Lastly, it may be possible to design a regenerative power source that does not need recharging.

One alternative is to recharge the lunar devices from a central power bank. This central bank can be a nuclear reactor or a large solar array. Either of these options can be connected to a bank of storage cells for energy collection during the lunar day. Then, during the lunar night, all the lunar devices can plug into the main bank and recharge. This option reduces the necessary power storage that any one lunar unit must carry. However, any external energy bank must be carried to the Moon. Additionally, if this energy bank was to fail, the lunar devices will not have a way to recharge.

The second alternative is to replace the lunar device's energy storage unit. This replacement means inserting new batteries or fuel cells into the device. A disadvantage to this alternative is that any replacements must be transported from Earth. Providing replacement power units will require regular flights for resupply. These resupply mission significantly increases the system's cost. Also, someone or something must be present to replace these energy devices. This replacement can be done by astronauts, but this entails sending people to the Moon, which is hazardous and costly. It may be feasible to perform this task autonomously. However, this will complicate the design task.

The last alternative is to design a system that does not require resupplying or recharging. As mentioned earlier, regenerative fuel cells (RFC) are one possible alternative. However, RFCs are not technologically feasible at the present time. If the device was to operate only during the lunar day, a device run purely on solar power will not need recharging.

However, solar cells may not be able to provide the amount of energy needed for operation of the device.

3.8 Coordination of Multiple Units

A proposed operational process is the use of a fleet, or team, of lunar devices. An advantage of this process is the degree of redundancy provided. If one device fails, there are others to complete the task of covering the lunar habitat with regolith. In addition, by using multiple units, the time for completion can be shortened. Two levels of control of the lunar devices are possible: overall control and local control.

Overall control entails having a central processor which coordinates all separate lunar units. This processor can double as a central locating device. However, such a processor adds to the expense of the design. It also requires equipment separate from the lunar units.

Local control can be done by several methods. Three methods were considered. The first method is enabling each device to detect its nearest neighbors. With this knowledge, a lunar device can avoid other units and prevent collisions. This alternative requires an increased level of computational power which will increase the overall cost of the design. This alternative also requires a method for each device to reliably detect its neighbors.

Another method of local control is to assign each device to a certain area of the lunar surface. The possibility of interference between units is then removed. Also, by restricting the device to a specific area the power

required for mobility may be reduced. A disadvantage is that this option requires a certain degree of computational power. Additionally, steps need to be taken to ensure that if a device fails, its sector will still be covered.

The third method of local control is for each device to operate independently of the other devices. If a device ran into another, it will treat the other device as an object to avoid, such as a boulder, and then turn and proceed on its own way. These turns can be random. However, random turns can lead the lunar device into an endless loop trying to avoid obstacles.

3.9 Obstacle Identification and Avoidance

In addition to traversing the lunar surface, the device must be able to recognize and avoid obstacles. Potential dangers such as boulders, craters or chasms, or a cliff can get in the way of the device and impede the device's progress. Some alternatives considered to perform this task are in-memory maps, sensors and on-board intelligence, mechanical systems such as a bumper or a spring-loaded pole, and teleoperation. Preliminary surface preparation is another method of obstacle avoidance.

The use of a map of the operation area ensures safe transit. By remote reconnaissance or local mapping, a lunar device can be provided with a map of all safe and dangerous areas. A map can also serve as a means for locating the device. A disadvantage of an internal map is that the map has to be generated before it can be placed in the memory of the device. This map generation requires extensive surveying, by either

human or device. The memory required to contain the map also increases the expense and complexity of the design.

Another alternative is a sensor array that allows the device to react to its surroundings. The bank of sensors can include a laser range finder, radar, and vision sensors. A sensor array will facilitate autonomous operation of the device. However, there are several problems with this option. Sensors will require extensive programming for obstacle avoidance. The device needs to be able to recognize an obstacle and then take action.

Two types of mechanical systems were considered for obstacle avoidance methods: a mechanical bumper and a spring-loaded pole. A mechanical bumper, as seen in Figure 24, can serve as an obstacle avoidance method by triggering a switch when the device comes across a boulder. The triggering of this switch will tell the device to change directions and proceed with its task. This direction change can be random or based on a map of territory previously covered. A random direction change might lead the device into repeating a path, precluding the coverage of new territory. A non-random direction change requires memory, which brings about the problems mentioned earlier. Another problem is that a bumper does not provide protection against cliffs or craters. A bumper switch will not be triggered by a cliff or a crater.

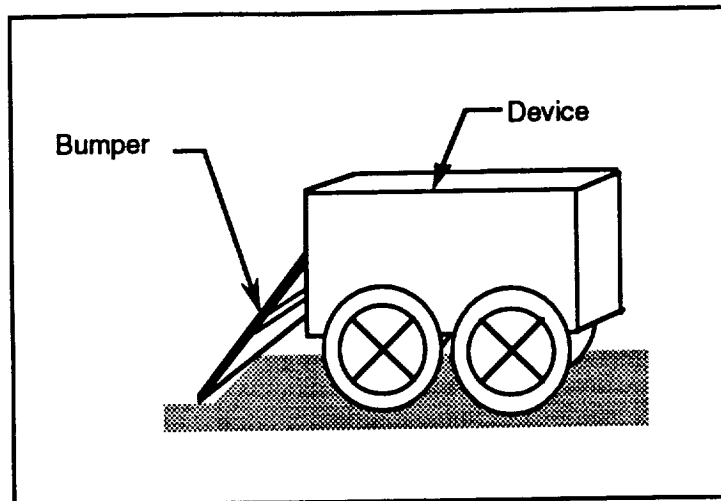

Figure 24. Mechanical bumper.

A spring-loaded pole, as shown in Figure 25, will work similarly to a blind person's cane. As the device traverses the smooth parts of the lunar surface a certain amount of deflection will be exerted on the pole. When a boulder or steep hill is encountered a higher deflection of the pole will occur. When a cliff or crater is encountered no deflection will be sensed. By sensing the change in deflection the device will know of the presence of an obstacle. A combination of a bumper and spring loaded pole will allow the device to detect all types of obstacles.

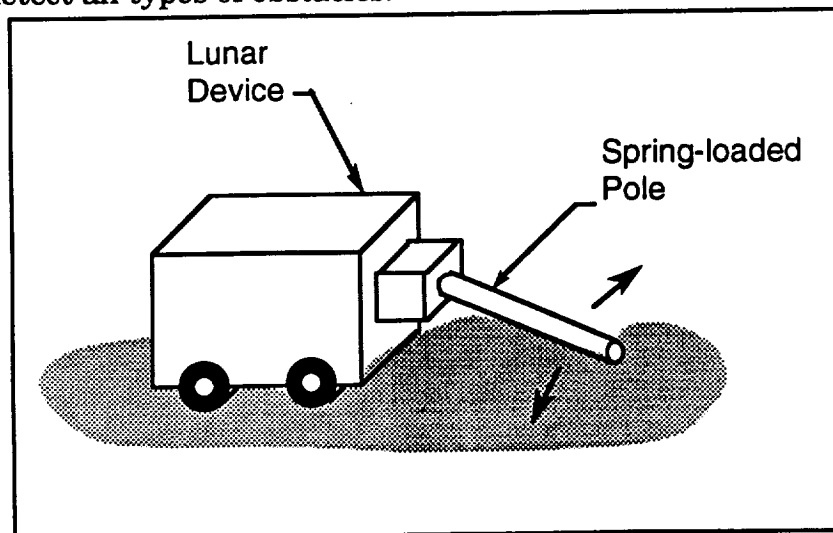

Figure 25. Spring-loaded pole configuration.

A human operator in the device's control loop can also provide hazard avoidance. By using cameras mounted on the device, a human operator can see the device's surroundings and decide on a safe path. This option requires communications capabilities between the device and the human operator. Communications raise the complexity and cost of the device. If the operator is on Earth a four second transmission delay from the Moon also needs to be considered [39].

Lastly, a suitable, although extreme, solution is preliminary surface preparation. By removing all hazards, the device can be assured of safe movement. However, such preparation can be quite extensive. Craters need to be filled, slopes need to be leveled, and rocks need to be removed. These activities require long periods of extra-vehicular activity (EVA) which is expensive and dangerous for the astronauts. Surface preparation can be done autonomously. However, autonomous surface preparation has the same problems as the other methods, such as control and obstacle avoidance.

3.10 Cooling and Heating of Unit

The temperature cycle on the Moon can lead to severe thermal shock problems. Temperatures on the lunar surface range between 120 K (-153°C) during the lunar night, to 374 K (101°C) at lunar noon [40]. Due to these extreme conditions, precautions must be taken to protect the device and any electronics it may contain from overheating or freezing. Cooling may be

needed during the lunar day and heating may be needed during the lunar night.

There are three possible modes of heat rejection: convection, conduction, and radiation. Convection is not feasible on the Moon due to the lack of atmosphere. Conduction to the ground is impractical due to the poor thermal conductivity of the regolith. The last method of heat rejection is radiation to deep space. Deep space serves as a perfect heat sink with an unlimited capability for heat absorption [41].

The cooling of the system during the lunar day must account for the internal heat generated by the device and external heating due to the extreme temperatures on the Moon. Large surface areas for radiation, such as fins, can be used to reject internal heat. A shading device, or an external radiator, can be used to cool the unit during the lunar day. A shading device, such as a mylar umbrella offers a simple, low power, and low mass method to cool the device. However, a shade may not provide the degree of cooling needed. It may be necessary to couple this shade with another cooling method.

An on-board coolant system, such as a freon-based refrigeration cycle, is another method to provide the overall cooling needed. However, there are several problems with such an alternative. Any system that uses a working fluid needs to be sealed against the near vacuum on the Moon. Without sealing, the fluid will boil away. Perfect sealing can be difficult and costly to obtain. In addition, a refrigeration cycle requires power to drive a pump and a compressor. A coolant cycle can also be a mass intensive solution.

During the lunar night, it may be desirable to heat the unit to prevent brittle fracture from the extreme cold conditions. A common solution for heating is to use a resistive heating element. A disadvantage of such a method is that it will increase the power requirements of the system.

Another solution for heating is to construct the device with materials that can withstand the extreme cold of the lunar environment. An advantage of this solution is it will add no extra equipment or mass to the device. The primary disadvantage of this solution is that cold-resistant materials will significantly increase the cost of the design.

A third alternative is to have the lunar device store itself for protection from the cold. To do this the device is simply programmed to go to a heated shelter when a certain temperature is detected. A disadvantage of this alternative is that it prevents the device from operating during the lunar night. This means that the device will sit motionless for 14 Earth days. Another drawback of this alternative is that the device will be required to transport itself to the shelter. Also, this solution requires that a heated shelter be built for the devices. Transporting the shelter materials to the Moon adds more mass to the total system. In addition, building a shelter for the devices could prove to be a challenging design task.

3.11 Cleaning of Lunar Dust from the Unit

A significant problem the device will face on the lunar surface is contamination by lunar dust. The top layer of the lunar surface is about ten centimeters thick and is composed of a very fine powder, almost like talcum

powder [42]. Lunar dust is electrostatically charged and adheres to most surfaces. Activities on the Moon disturb this dust, creating dust clouds. If not removed, the dust will cover optics or solar cells, limiting their effectiveness. The lunar dust can also abrade moving parts, causing premature erosion and failure. Several methods are considered for the removal of lunar dust. These methods consist of using electrostatics, vibrations, brushes, and fluids or compressed gas.

Due to the electrostatic charge inherent in lunar dust particles, it is possible to charge a surface and repel the dust particles. However, high voltages are needed for repelling the dust. Voltages needed are on the order of 11 kV [43]. With the power sources currently available for lunar use, it is not possible to directly create this voltage. Transformers can be used to step up the voltage. However, transporting a transformer to the Moon greatly increases expenses. Additionally, a voltage level of 11 kV is potentially hazardous to personnel.

Another alternative is to vibrate the mechanism to shake loose the lunar dust. An advantage of this alternative is that it requires low power levels. However, vibrations can damage any sensitive electronics contained in the mechanism. Also, unless the vibrating is done off the ground, vibrations will stir up even more dust.

A third alternative to remove lunar dust from the device is to use brushes to physically remove the dust from contaminated surfaces. The chief advantage of brushes is that they are a low power, low complexity alternative to dust removal. However, brushes will scratch any optical systems in the device. Scratches will seriously affect the performance of optical systems.

The fourth alternative consists of using compressed gas, fluids, or gels to wash or blow off the lunar dust. A problem with this alternative is that these fluids or gels must be periodically replaced, as they are used by the lunar device. An advantage of this alternative is that a fluid or gel will not damage any sensitive optical surfaces.

3.12 Storage of Unit

Another task that may be necessary is the storage of the lunar devices. If it proves unfeasible to operate at night, the lunar devices need to store themselves for protection from the cold. At the very least, the lunar devices need to power down for energy conservation. Also, it may be desirable to store the units upon completion of their task. Three options were considered for the storage of the devices: a storage shed, burial of the devices, and simply parking.

The unit can be programmed to go to a storage shed whenever it is necessary to shut down. The device will then wait to be reactivated if necessary. This shed can be environmentally controlled, which will protect the lunar units from the extreme cold and solar flare radiation. The primary disadvantage of this alternative is that such a shed must be transported to the Moon and assembled. This added mass and work complicate the process and increase the overall system cost.

Another possible alternative is to design the units to bury themselves upon shutdown. If buried at a sufficient depth, the regolith surrounding the lunar devices will protect them from the extreme cold and solar flare

radiation. However, self-burial may be power intensive and will increase the problems the device faces with dust contamination.

Lastly, the devices can be programmed to simply shut down and remain where they are. This method leaves the devices exposed to the harsh environment. Yet, additional materials are not needed for the construction of a shelter. The success of this method hinges upon the ability of the device to withstand the lunar environment for long periods of time at night.

DETAILED ANALYSIS OF REGOLITH PLACEMENT METHOD

This section presents a feasibility study of throwing for the regolith placement method. The section then presents an analysis of linear versus rotational throwing and a comparison of methods to energize the throwing mechanism. Based on the criteria, advantages, and disadvantages presented in the following section, a linear throwing method using a spring energized by an electrical motor was selected as the most feasible throwing alternative. Methods to lock and release the throwing mechanism were not studied in this project and need to be developed for the final design.

4.1 Feasibility of Throwing

The primary function of this design is the placement of regolith on the habitat. A possible method of placement is throwing the regolith from where it is gathered to the habitat. Throwing regolith, instead of carrying it, is a completely new concept. The lunar environment provides several advantages for throwing, as mentioned earlier in this report. The low gravity on the Moon allows for lower energy and power requirements to throw the regolith. Also, the lack of an atmosphere on the Moon eliminates aerodynamic drag and decreases the tendency for the regolith to spread when thrown. Figure 26 compares the paths of motion of a mass thrown on the Earth and a mass thrown on the Moon. A more detailed analysis of the path of motion is presented in Appendix C.

One step in determining the feasibility of throwing regolith was comparing throwing to traditional terrestrial dirt placement methods. As presented in the alternative designs section, the dirt placement methods considered were a conveyor belt configuration, a bucket system, and a front loader.

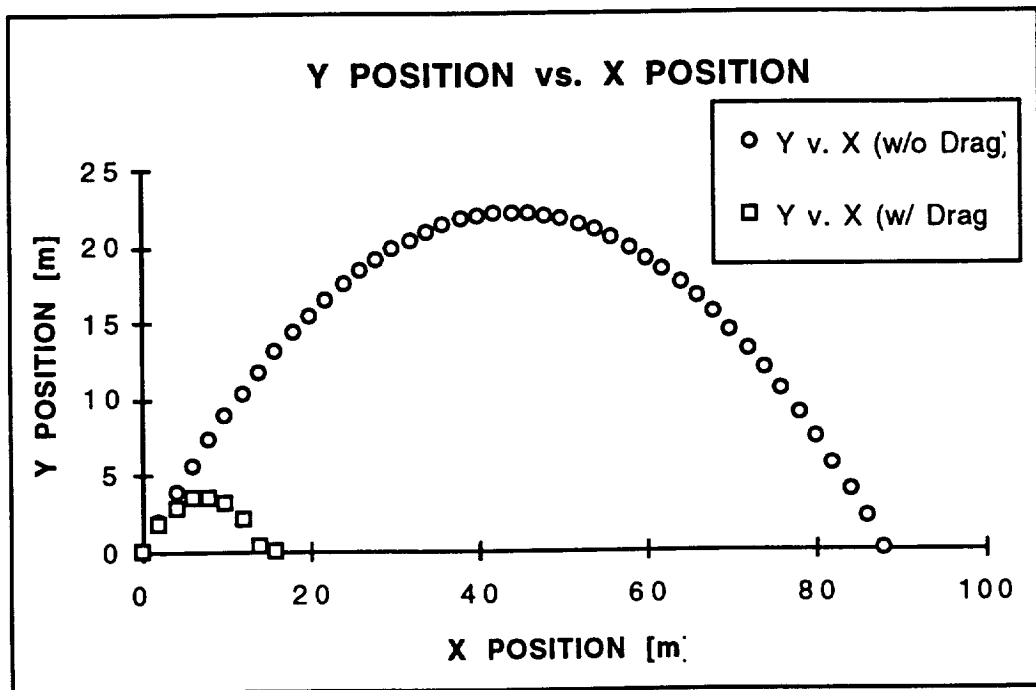

Figure 26. Paths of motion of a particle thrown on the Moon as compared to the Earth.

Five criteria were used in the comparison of these alternatives. The five criteria are system modularity, amount of work necessary for transport and placement of the regolith, total mass of the system, ease of installation and removal of the system, and level of redundancy or reliability provided.

Based on these criteria throwing was selected as the most feasible option. Appendix D presents the analysis of the feasibility of throwing.

The first criterion, modularity, is very important for any device that operates on the Moon. A modular device is simpler to repair and modify. Any broken subsystem in a modular device can be replaced by a new subsystem module. The entire device does not need to be taken apart. This aspect of modularity minimizes the downtime, or the time out of service, for a device. A modular device is also easy to modify. The expense of transporting items to the Moon is enormous. Therefore, any device that can fulfill more than one purpose eliminates the need for completely separate devices. This minimizes the overall cost of the system. The modularity of the conveyor configuration, the bucket configuration, and the front loader is limited. Although the systems can be transported to the lunar surface in pieces, modularity has two aspects, as mentioned earlier. The second aspect, ease of modification, is not easily fulfilled by any of the terrestrial methods. The configurations are limited to regolith movement and not easily adaptable to another purpose. A front loader may be used for remote surveying or hauling cargo. However, a front loader needs to be redesigned to take full advantage of modularity. An Earth-based front loader is designed solely to transport soil.

These systems must all perform a certain amount of work to cover a habitat and this work is the next decision criterion. Work done by a system is a crucial element. This work is directly related to the amount of energy storage a system must have. The lower the amount of work needed, the smaller the power storage system. A smaller power storage device translates into lower mass and lower costs. Analysis was done on the work

required to place the regolith on top of the habitat by throwing it and the work to place the regolith by carrying it. While a conveyor or bucket system does not carry regolith, regolith must still be provided. This regolith will have to be transported to the conveyor or bucket system. This regolith can either be thrown or carried.

Analysis shows that a work savings of 30% to 55% is possible if the regolith is thrown. As shown in Figure 27, the work saved by throwing regolith increases as the device moves away from the habitat. The energy required for carrying the regolith is essentially the distance the device must travel multiplied by the rolling resistance. Because the device must travel from the collection site to the habitat and back, the distance traveled increases with more than twice the radius of the area cleared. In contrast, the distance the regolith must be thrown increases with the radius of the area cleared. This analysis favors a throwing device. While it is possible to throw regolith to the conveyor or bucket systems, work is still needed to place the regolith in the system and then transport this regolith onto the habitat. The throwing device avoids this by directly placing the regolith on the habitat, gaining an energy savings.

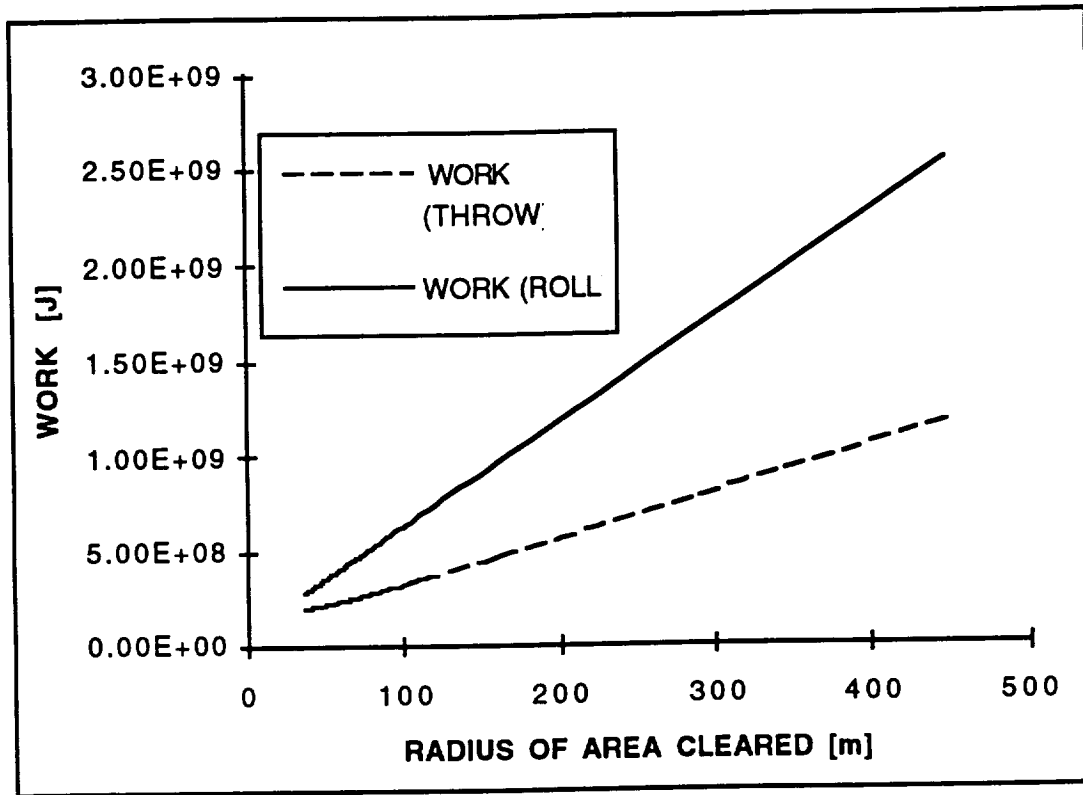

Figure 27. Work comparison between throwing and carrying

As mentioned earlier, it is expensive to transport material to the lunar surface. Therefore, the smaller and less massive the device, the lower the overall system cost. The conveyor belt and the bucket systems are both very large and massive. To reach the top of the habitat a 24 meter long conveyor belt is required (see Appendix D). A bucket assembly needs to span the habitat to enable regolith placement on the top. A structure is needed to support either of these systems. The structure is additional mass that must be transported to the lunar surface. The front loader system is also massive. A front loader designed for mining purposes on the Moon has a volume of 21 m³ and weighs 2600 kg [44]. To reach the top of the habitat in this application the front loader needs to be much larger than the

mining vehicle. The weight of the regolith load to be dumped and the large size of the arm needed to reach the top of the habitat create a large moment on the front end of the loader. This moment must be counteracted by the weight of the rest of the device or by a counterweight. If no corrections are made for this moment, then the device will be unstable and tip over. A hopper filled with regolith can be used to provide the counterweight. If the hopper is near the device, a large amount of regolith will be needed. The hopper can also be placed away from the device, increasing the moment arm. However, this option increases the overall size of the device which is undesirable. The lunar throwing device, with an estimated mass of 150 kg and a system mass of 1500 kg, is competitive with any of these terrestrial systems, with respect to mass.

The fourth criterion, system installation and removal, is important for safety reasons. Unless the system automatically or remotely deploys, astronauts are needed to install the system on the lunar surface. The astronauts will have to venture out into the harsh and dangerous lunar environment. A system with a short installation and removal time minimizes the astronauts' exposure to the extreme temperatures, near vacuum, and intense radiation on the lunar surface, which reduces the chances of a mishap occurring. The conveyor and bucket systems both require extensive initial installation time and are not easily removed from the lunar surface when the task is completed. These systems will have support structures that must be set up around the lunar habitat. The front loader, as well as a lunar throwing device, can be deployed from a lander module on the lunar surface. Deployment consists of simply driving the

mechanism out of the lander. A front loader or a lunar throwing device offers significant time savings during installation and removal.

As mentioned earlier, it is expensive to carry materials to the lunar surface. Therefore, any system which operates in the lunar environment needs to be redundant and reliable. If part of a system fails, then that system must still be able to accomplish the task. Redundancy can be achieved either through multiple redundant subsystems or through durable design. Due to the harshness of the lunar surface, it is easier to provide a system that uses multiple redundant subsystems.

The large mass and volume of the conveyor, bucket, and front loader systems, discussed earlier, prevents the use of more than one system. The use of only one system provides no degree of redundancy. However, a fleet of lunar throwing devices offers a high degree of redundancy. With more than one device present, if one fails then the others can still fulfill the task of covering a lunar habitat.

When all of the aforementioned criteria are taken into account, a device to throw regolith proves superior to a device that carries regolith. It is interesting to note that this result is the opposite of what is seen on the Earth. As mentioned earlier, the throwing of dirt is a new and novel concept. This idea is so new that it has never been addressed before. On Earth, it is easier to carry dirt. However, on the Moon, it is indeed more advantageous to throw regolith, rather than carry it.

Functions such as powering and mobility have been addressed in previous designs of lunar devices. An example of this is the LRV, the Lunar Rover Vehicle. Throwing is a major new concept in this design. For

this reason, the design team focused on the development of a throwing mechanism.

4.2 Comparison of Linear and Rotational Throwing

Once throwing was selected as the transport and placement method, the actual throwing mechanism needed to be chosen. The criteria used in the comparison of linear versus rotational throwing mechanisms were the effect on dispersion of the regolith as it is thrown, instabilities imparted to the overall design, ease of changing the release angle, and ease of reloading. This analysis can be found in Appendix E.

The first criterion is the dispersion, or spreading, of the thrown load of regolith. A rotational mechanism imparts a linear velocity gradient across the face of the regolith load. The outer portion of the load travels farther than the inner portion, dispersing the regolith as it is thrown. This effect is not present with a linear throwing mechanism. Linear motion improves the possibility of the regolith leaving the throwing mechanism as a slug, or solid mass. If the regolith leaves the device with uniform velocity and acceleration vectors, the degree of regolith dispersion will be minimized. The effect on dispersion due to friction between the load chamber walls and the regolith is unknown. The same effect should be seen by both throwing methods and was therefore assumed negligible in later analysis.

When the device throws the regolith load, it must not tip over in response to the momentum of the throw. A rotational throwing

mechanism will cause more problems with instability than a linear mechanism. A rotational arm imparts a greater momentum change to the device increasing the tendency for the device to flip over when throwing.

The next criterion is the ability to alter the release angle. Various launch angles can be attained by altering the release point of a rotational mechanism. The motion of a rotational arm acts to alter any release angle setting. This rotational motion can affect the precision of the release angle. A linear throwing mechanism, however, uses a launch platform to alter the release angle. With a launch platform, more accurate changes can be made to the release angle.

The last criterion is the ease of reloading the throwing mechanism. Regolith must be placed in the load chamber before every launch. For a rotational mechanism, the arm must physically be moved back into position for reloading if it progresses past 90 degrees. This motion will require additional power, time, and a mechanism to reset the arm. A linear throwing mechanism, with a launch platform, will be tilted for release. The load chamber will then tend to fall back into position for reloading. Additional power may be needed to reset the load chamber, depending on the system configuration.

Based upon the above considerations a linear throwing mechanism was selected for the final design. Linear motion decreases the stability problems seen with a rotational mechanism. Linear motion also minimizes dispersion.

4.3 Throwing Energizing Method

Once a linear throwing configuration is selected, a means is needed to power the mechanism. There are several alternatives for powering. The options considered are chemical propellants, electric motors, flywheels, magnetic fields, and springs. The energizing method selected needs to be reliable and efficient, provide the necessary acceleration to throw the regolith the distance required, be easily coupled to linear motion, and have a minimum number of moving parts. For reasons covered earlier, the mass, volume, and power requirements of the selected method need to be kept low, to minimize the size and cost of the device. An analysis of throwing energizing mechanisms is shown in Appendix F.

4.3.1 Chemical Propellants

The first energizing option is chemical propellants. A propellant-based option will operate similarly to a shotgun to provide the needed linear motion. By varying the release angle, or changing the volume of the firing chamber different distances of throw can be obtained. Changing the volume of the firing chamber will allow for the fuel to expand or compress a different amount, creating different launch accelerations. Explosions, however, may adversely affect the electronics and other components of the device. If people are working around the lunar devices, explosions may also be hazardous. Another disadvantage of this method is that the propellant will have to be supplied from Earth or manufactured on the lunar surface. Either of these options increases the operating costs of the

system. The propellant also has to be reloaded after every launch of regolith.

4.3.2 Electric Motor

An electric motor is another possibility for energizing a throwing mechanism. The electric motor offers a compact method to power the load chamber. A motor can be connected directly to the load chamber. An electric motor, however, will be difficult to link directly to linear motion. A separate linkage will be necessary to translate the motor's rotational motion to a linear throwing motion. A motor will also have a high starting torque and peak power requirement.

4.3.3 Flywheels

A third method to store energy for throwing is a flywheel. A flywheel is a large disk that stores potential energy obtained from the load as rotational kinetic energy. The energy is transferred to and from the flywheel through a clutch mechanism. Flywheels, however, have high rotational rates and rely on many moving parts. These factors cause reliability and maintainability problems. If low rotational rates are used, large masses and prohibitively large diameters are necessary to store significant amounts of energy. Also, flywheels are difficult to couple to linear motion. An advantage of flywheels is that the energy stored on them can be quickly transmitted from the flywheel to the system to meet peak

power requirements. Using this method, a motor does not need to generate the peak power requirements of the system.

4.3.4 Magnetic Fields

A magnetic field is the fourth energizing possibility. A magnetic field can be used to propel the regolith load chamber, according to Faraday's Law of Induction. A fluctuating magnetic field induces a current in the rail which projects the load forward. However, a long track, approximately 150 m, is needed to accelerate the regolith to the needed velocity. Any magnetic field generated may also affect the electronics of the lunar device.

4.3.5 Springs

Springs are the last option considered for throw energizing. Springs can be used as energizing methods either by themselves or by being coupled with an electric motor. Springs can be used as the only energizing method by using the weight of the gathered regolith as the compression force. This method was unfeasible for our application. The collected regolith will not provide the necessary force to compress the spring. Springs have the advantage that they can be loaded very slowly, thereby reducing power requirements. By varying the compression distance of the spring, different throwing distances can be achieved. To provide the extra force for compression, the spring will be energized by an electric motor.

4.3.6 Selection of Energizing Method

Based on the quantitative analysis of the energizing methods, presented above and shown in Appendix F, a spring energized by an electric motor was selected. The motor and spring arrangement was selected since it proved superior in a comparison of geometry, power, and torque requirements. The motor can be geared to achieve the necessary torque required to compress the spring. The power to compress the spring can be obtained by tapping power from the motor in the drive train.

OVERALL DESIGN CONFIGURATIONS

Once the linear throwing mechanism, using a spring and electric motor, was selected, the next step was integration into an overall design. This section presents the integration of the throwing mechanism into three overall system configurations.

The design team did not select an optimum alternative for each function. Three possible overall configurations are presented to illustrate various function solutions. The features of each configuration were selected based on a qualitative analysis of the alternative designs discussed earlier in this report. Specific solutions were selected for the functions for which the design team had enough information to make a qualified decision, or for features which had been proven feasible in prior lunar vehicles. The selections were based primarily on the following criteria: minimizing mass, volume, and power of the units, reliable operation in the lunar environment, and availability of technology.

Cost is another factor that needs to be addressed. However, limited information on the cost of each component prevented the design team from directly considering cost in the selection of the overall designs. By minimizing the mass and volume of the devices, the transportation cost of the system is lowered.

5.1 Selection of Alternative Solutions

The first step in overall configuration selection is to choose alternatives. As discussed earlier, a linear, spring-driven throwing mechanism is the chosen throwing solution. There are four other functions of the device that the design team had enough information on to select a superior option. These components are RTGs for powering the system, four hemispherical wheels for mobility, compressible gases for cleaning of lunar dust, and assigning each unit to a certain area of operation for coordination of multiple units. Reasons for selecting these alternatives are described in the following subsection. These four functions form the basis of the three overall configurations that follow. Other functions such as the regolith gathering method, the determination of the finishing point, and the navigation and control system are functions unique to each configuration.

5.1.1 Powering

One solution common to all three configurations is the power unit. RTGs were selected by the design team to provide the electrical power for the device. RTGs have long lifetimes, high reliability, and have successfully operated in the harsh lunar environment on five separate Apollo missions [45]. MOD-RTGs currently being developed will provide between 19 and 342 W of electrical power. RTGs offered the most mass-efficient option of the powering systems considered. A disadvantage of

RTGs is the political implications of placing a nuclear-powered device on the moon.

5.1.2 Mobility

Another common feature are the wheels. Hemispherical wheels were selected for the drive mechanism of the three configurations. These wheels have a greater weight bearing capacity and are more durable than wire mesh wheels or flexing metal wheels. The treads on the rims of the hemispherical wheels provide better traction. A wheeled vehicle was selected over a tracked vehicle. Tracks are more vulnerable than wheels to damage from the lunar surface. Rocks on the lunar surface can easily jam a track. Wheels also have fewer moving parts which will increase reliability.

A four-wheeled vehicle was selected. Previous four-wheeled lunar rovers were able to safely traverse the lunar surface. Therefore, if the soil and terrain characteristics at the operation site are similar to the Apollo 11 landing site, the four-wheeled driving mechanism will operate successfully.

5.1.3 Cleaning of Lunar Dust

A third shared solution is for the cleaning of lunar dust from the device. Previous analysis and research into methods of cleaning lunar dust from sensitive components and optics recommend the use of compressed

gases. This method was found to be the least damaging to the components when compared to brushes and vibrations [46].

5.1.4 Coordination of Multiple Units

The last common alternative is the coordination of the fleet of lunar devices. Unit coordination is a function that will depend on the technology available at the time of the mission. Assigning each unit to a certain area of operation was the method of fleet coordination selected by the design team. This method will prevent collisions between units. How the failure of one unit will affect the overall system process will depend on the method used to determine the finishing point. If a beacon network is used the failure will not prevent the task from being fulfilled. If a rate-dependent method is used, a supervisory control system is needed to inform the other devices of this failure.

5.2 Overall Design Configuration # 1

The first configuration, shown in Figure 28, uses the bulldozer, or ramp, modification to cut and transport the regolith to the load chamber. The lower end of the ramp has a blade that loosens the regolith. The regolith travels up the ramp and falls into the load chamber. The launch platform then pivots about axis AA to point towards the habitat. Small power screws are used to lift and lower the upper platform allowing it to pivot about axis BB. The load chamber is then guided back as the spring is

compressed. When the needed compression is achieved, the load is released. Advantages of this configuration are that the spring can be coupled to the motor of the drive train. Also, the throwing mechanism has a 360 degree throwing range.

Using the ramp as the gathering method is a simple method for collecting the regolith. However, a ramp option requires high tractive forces and has several geometric limitations. If the angle of the ramp is too steep, the regolith will not slide up the ramp. The regolith will simply be pushed forward. Information was unavailable for an investigation of this problem. After a preliminary analysis, the design team concluded that the ramp will work if the angle of the ramp is less than the angle of repose of the regolith.

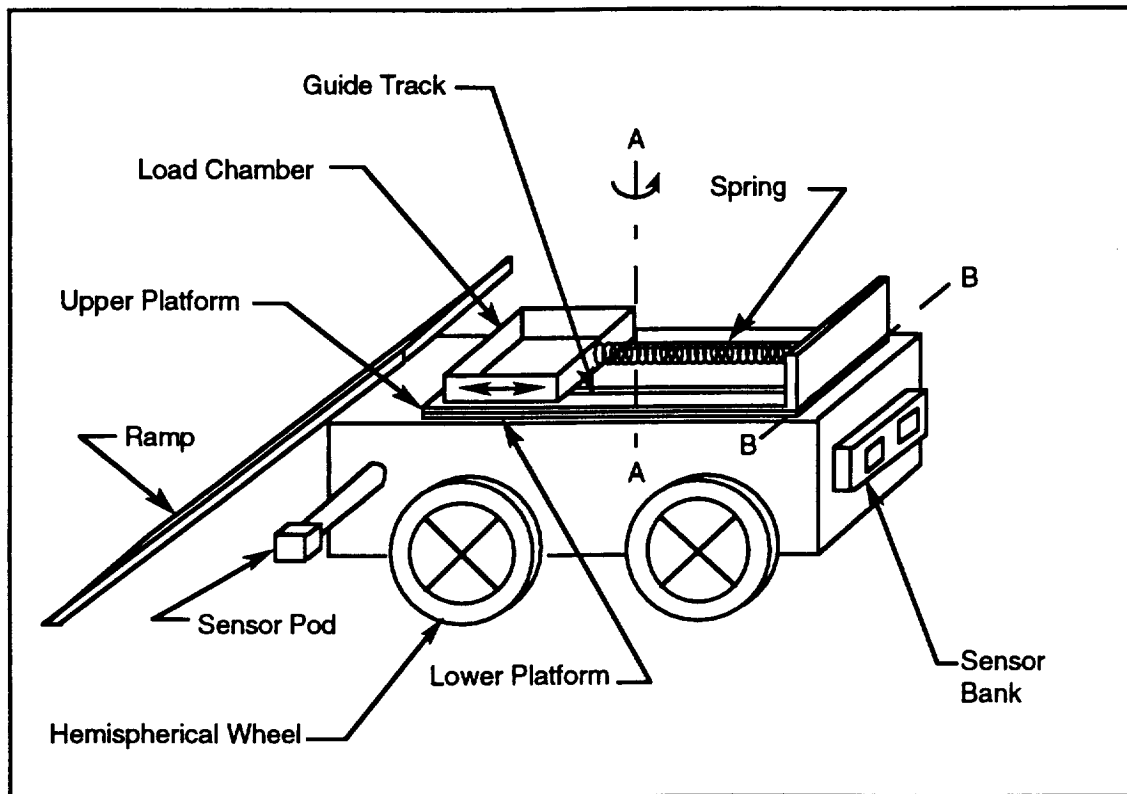

Figure 28. Overall Design Configuration #1.

To provide for redundant positioning information, a beacon network with small radar transponders coupled with an inertial navigation system (INS) was the navigation and location system selected for this configuration. The absolute system, a network of beacons, can be used for periodic updates of the INS, which is a relative positioning system. A disadvantage of this solution is that the network of beacons adds mass to the system and requires additional set-up time. Also, programming of the lunar devices is needed, as a map of the beacon network is required to enable the location of the lunar devices.

Indicators on poles, as discussed earlier, will be placed on the lunar habitat to determine the finish point for regolith placement. The indicators on the poles can also be used as part of the positioning beacon network.

5.3 Overall Design Configuration # 2

The second configuration is shown in Figure 29. The main features of this configuration include a scarifier to rake out large rocks and loosen the lunar soil prior to collection, an inclined ramp for regolith collection, and a spring-loaded bumper for obstacle avoidance. On-board sensors and a beacon-proximity detection system are used for targeting the habitat, finding the distance and angle of throw, and determining when the task has been completed.

The collection ramp is positioned high enough so that the throwing arm can rotate through its center axis (axis AA) providing a 180 degree

throwing range. To achieve the launch angle a platform attached to the throwing arm pivots about axis B. Walls are used on the sides of the ramp to guide the regolith and prevent the regolith from sliding off the sides. Figure 29 shows the stowed position and a throwing position of the throwing mechanism. An advantage of this system is the ability to load the collection bin without having to rotate the throwing mechanism back to the stowed position. If the device travels around the habitat in an arc, the throwing mechanism automatically points towards the habitat after loading. The only time the mechanism needs to move is during travel towards or away from the habitat or for calibration.

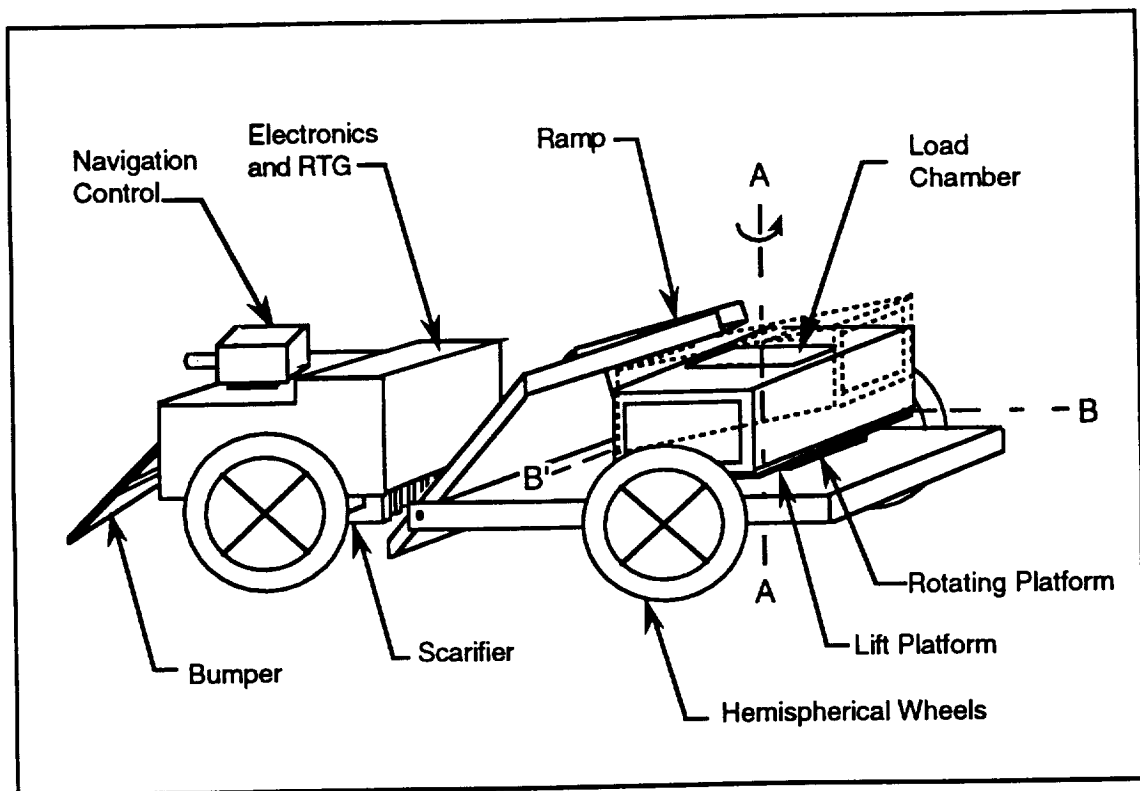

Figure 29. Overall Design Configuration #2.

A beacon-proximity detection system was selected as the absolute positioning system for this configuration due to its simplicity. Using one beacon placed on top of the habitat allows position calibration from a single reference point. The beacon emits a continuous signal which is detected by sensors mounted on the device. When the beacon is covered, no signal is sensed by the units and the covering of the habitat is complete. A disadvantage of this system is that if the single beacon fails then there is no backup system.

An on-board system for hazard identification will be used by this device. A spring-loaded mechanical bumper was selected since it provides a simple, reliable method to identify obstacles. This method identifies a hazard but does not tell the device what to do to overcome it. To solve this problem a supervisory controller is integrated into the configuration. When a hazard is encountered the mechanism will stop and wait for a teleoperator to signal what to do. By performing periodic check-ups an operator can make sure the devices are operating properly, make minor corrections, and coordinate the position of the fleet of devices. The teleoperator will also supervise the initial deployment of the units and guide the devices to their starting position. In order to use this control system, communication capabilities between the Moon and the Earth are required.

5.4 Overall Design Configuration # 3

Figure 30 shows the third configuration. This device uses a scooper to gather the regolith and throw it onto a conveyor belt. The belt then carries

and drops the regolith into the load chamber. The load chamber is then pivoted and raised to target the habitat and the regolith is launched. With this configuration the throwing range is limited to about 90 degrees.

Laser triangulation is the basis of the navigation and positioning system selected for this configuration. An advantage of laser triangulation is available laser range finders are currently achieving 0.06% percent range accuracy at 10 km [47]. For the travel distance required for this application, the accuracy of this system will be on the order of 0.05 m.

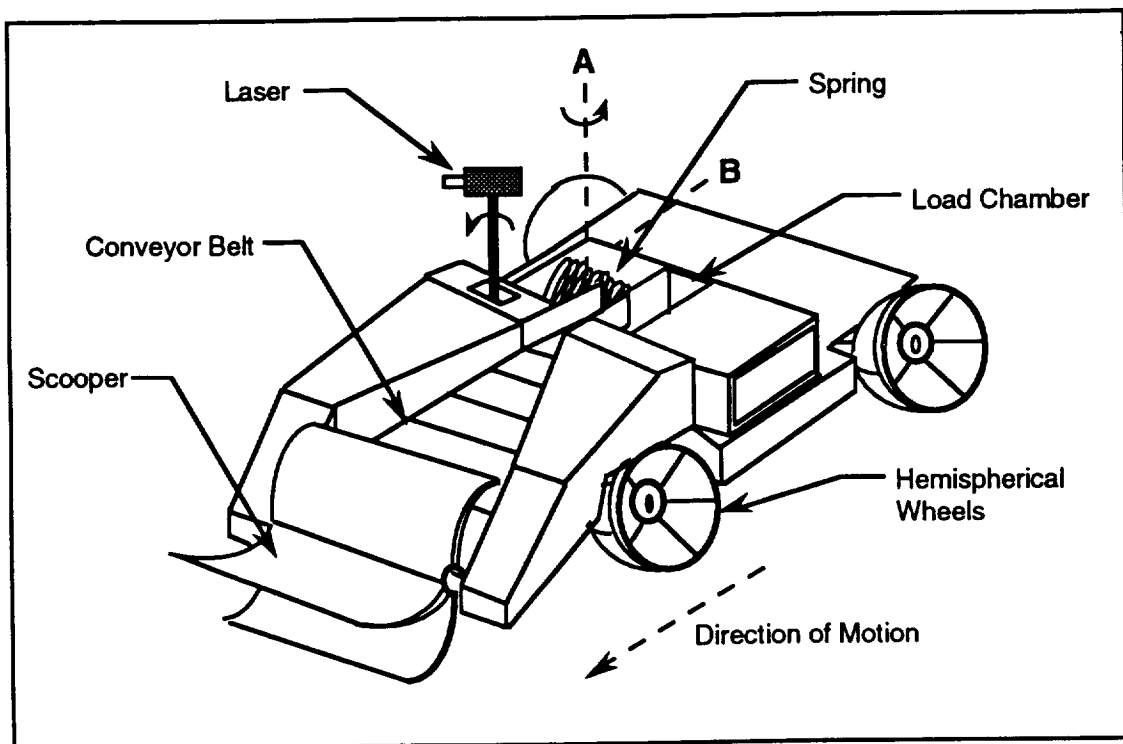

Figure 30. Overall Design Configuration #3.

To determine the finish point the number of throws performed by each unit will be counted until a certain preset number is reached. This option has the disadvantage that if a unit fails the habitat will not get

completely covered. To compensate for the failed unit, the throwing rate of the remaining units must increase. A supervisory system is needed to supply this information to the remaining units.

5.5 Configuration Selected for Computer Simulation

The first configuration was selected by the design team to perform a computer simulation displaying the dynamics of the system. This configuration was selected because of geometric and operational simplicity. The dimensions for the design, shown in Figure 31, were scaled based on information presented in the following section. The device is 0.4 m tall with a 0.2 m ground clearance. The width of the device is 0.66 m and the length of the body is 1 m. The overall length of the device including the blade is approximately 2.8 m (see Appendix L)

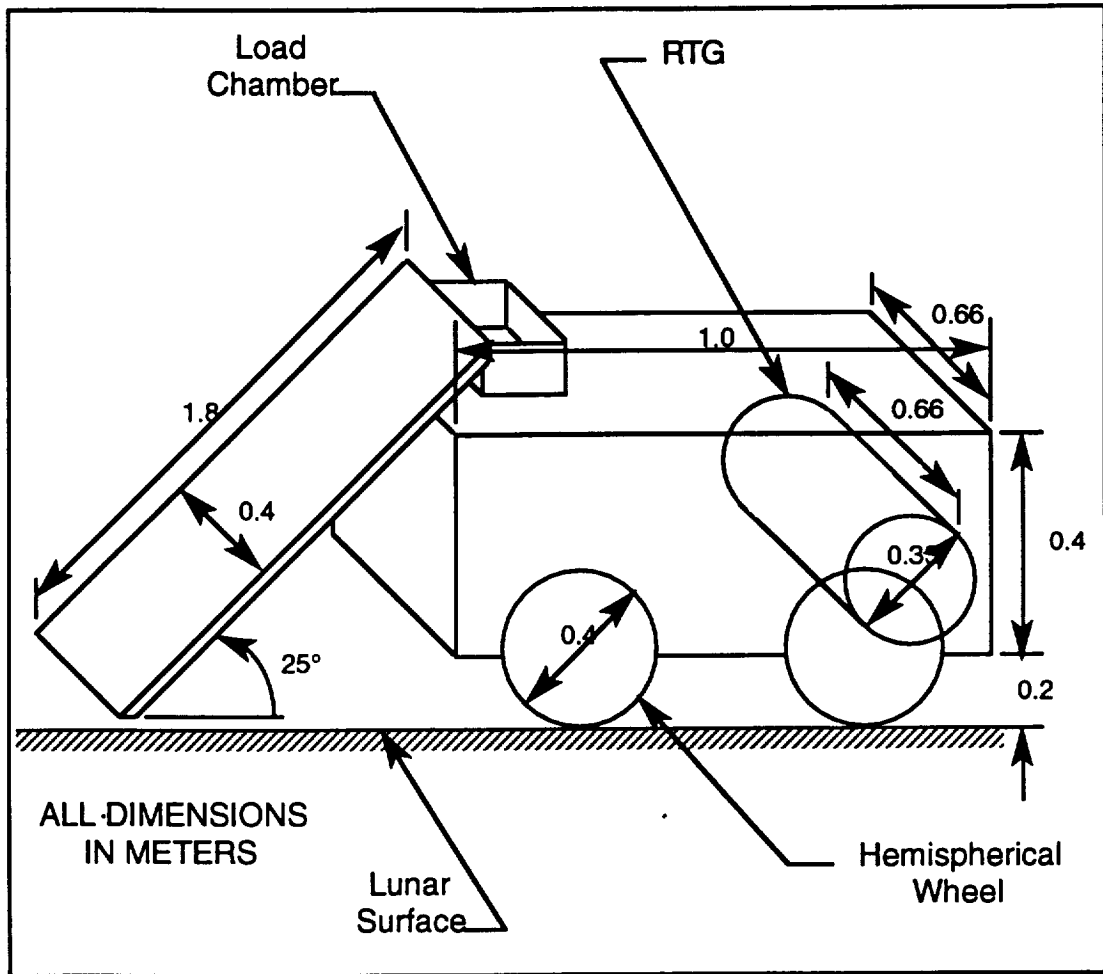

Figure 31. Scaled configuration for computer simulation

SYSTEM DESIGN

To further demonstrate feasibility, operational parameters for both the system and the lunar device were needed. Power requirements and number of units in a fleet are some examples of operation parameters. To obtain power requirements and the size of the spring needed for this application, the size of throw, number of units, time for completion of task, and the size of the habitat to be covered were needed.

The first overall configuration was selected by the design team for system refinement. This configuration was selected for the reasons mentioned above. A simple configuration was superior due to the limitations of the computer model.

6.1 System Parameters

One of the primary system parameters is the time for job completion. The time to complete the covering of the habitat was selected by the design team to be a lunar day (14 earth days). This time period was selected to prevent the devices from working during the extreme cold of the lunar night. The amount of regolith that the devices have to move in this one lunar day is 3140m^3 , as calculated in Appendix G.

Another critical parameter was the number of units required by the system. By examining a comparison of the volumetric rate of collection per unit versus the number of units needed to perform the task in a lunar day, the design team selected ten units for the system. In general, lowering the

effective volumetric rate that each unit throws lowers the frequency of movement. Figure 32 shows a plot of the volumetric rate of collection for each device as a function of the number of units. This function cannot be minimized as it continually decreases. However, the advantage gained by adding more units begins to decrease after about ten units. Also, using ten units provides a good redundancy factor. An detailed analysis of this is shown in Appendix H.

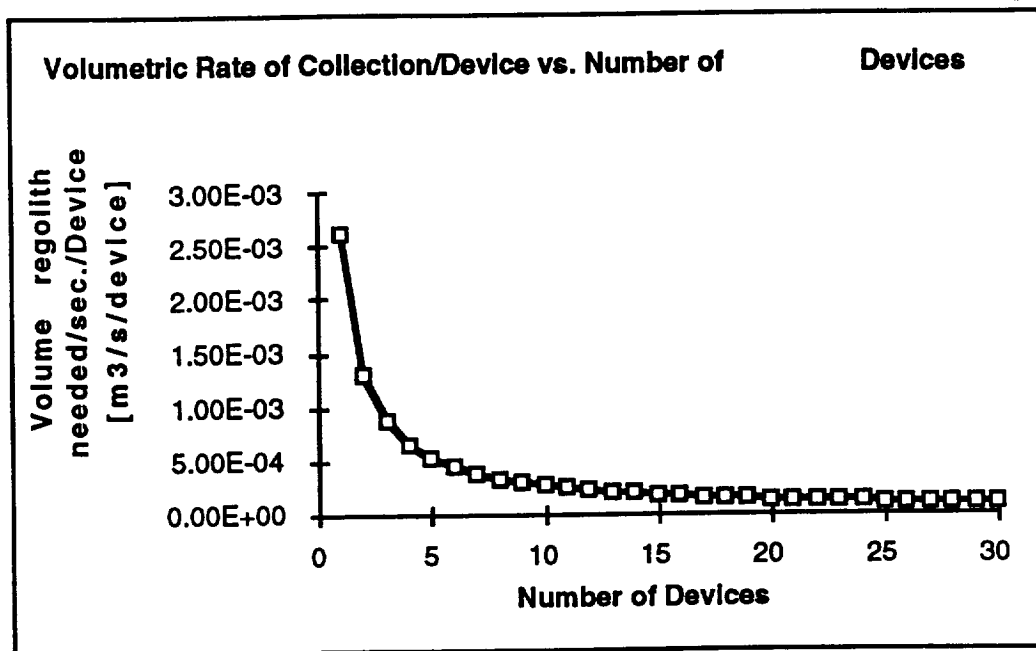

Figure 32. Volumetric rate of collection per unit vs. number of units

Another parameter which needed to be chosen was the depth of dig. Decreasing the depth of dig increases the surface area to be cleared to gather the required regolith. The energy required to throw the regolith also increases as the device moves away from the habitat. Essentially, the work necessary to throw the regolith decreases as the depth of dig increases.

However, the advantage gained by increasing the dig depth begins to reach an asymptotic value as the dig depth reaches 20 cm. Using information generated in Appendix D, the depth of dig was chosen to be 20 cm.

After determining the depth of dig, it was necessary to determine the depth of regolith the device clears per pass. For example, the device might operate more efficiently by making two passes of ten centimeters rather than one pass of twenty centimeters. A derivation of the most efficient depth of dig per pass was performed and is shown in Appendix I. Based on a minimum work analysis, the optimal depth per pass is about 50 cm. However, the force necessary to cut at a 50 cm depth greatly exceeds the traction generated by the device. Analysis done on the traction generated by the device shows that this traction limits the force available to scrape the regolith (see Appendix J). As a result of the generated traction, the depth of dig per pass was chosen to be 5 cm. A deep cut per pass is more efficient for gathering regolith. However, deep cuts require higher cutting forces, the scraper blade geometry is designed to create as little cutting force as possible.

The remaining parameters that needed to be were the number of throws per unit time and the size of each throw. These two parameters are linked together by the volume of regolith that must cover the habitat and the time allowed to complete the job. Because the first configuration gathers the regolith and throws the regolith in separate steps, it was necessary to determine the amount of time spent performing each procedure to minimize power. With these parameters determined, the velocity at which the device moves and the rate at which the spring is compressed are found.

The procedure used to determine the time for one cycle and the size of the load thrown is detailed in Appendix K. The result is each unit moves at 5 cm/sec, and collects and throws a regolith load volume of $20 \times 20 \times 20 \text{ cm}^3$ (11.72 kg) every 30 seconds. Twenty-five percent of this time will be spent by the device gathering the regolith to be thrown. The rest of the time will be used for targeting the habitat, compressing the spring, and launching the regolith.

Factors involved in these results include device geometry, required traction, generated traction, and efficient power usage. A decision was made to balance the cycle time with the volume of the regolith thrown. A large cycle time was desired to decrease the number of cycles the device had to perform as well as the rate of mechanical movement required of the device. In contrast, long cycle times require a large volume of regolith thrown. An attempt was made to minimize the volume of regolith thrown to reduce the needed compression force of the spring. Also, a large thrown volume results in a larger overall device. To launch the 11.72 kg mass at a maximum launch velocity of 12 m/sec a throwing mechanism with a spring constant of 6.75 kN/m and a maximum compression distance of 0.5 m is needed. The continuous power required by this device is approximately 200 watts. The power analysis is detailed in Appendix L. With these specifications the device has a maximum throw of about 80 meters.

6.2 System Mass

One of the key parameters of the lunar device is the mass of the total system. The mass of the vehicle needs to take into account the power, navigation and control, and communications systems in addition to the vehicle's structure and drive mechanisms. A first order approximation of the vehicle's mass was obtained by assuming that a typical vehicle structure and drive mechanism will carry its own weight on payload [48]. The mass of the blade, power system, and targeting system were first obtained. This amount was then doubled to account for the structure and drive mechanism. The mass of each device was found to be approximately 150 kg. This mass compares to the 218 kg mass of the Lunar Rover Vehicle [49]. With ten devices, an approximate system mass is 1500 kg. This mass does not take into account the sensors and poles required if the sensor array is used for targeting. A more detailed explanation of the mass analysis can be found in Appendix L.

6.3 Power Requirements

Another crucial parameter is the power system of the lunar device. The power system will supply the power necessary for overall vehicle operation. Power requirements include navigation and control system, mechanical systems, mobility, and all data systems.

The significant energy consumption of the device is for the gathering of the regolith, the compression of the spring, and the movement of the

unit. The nominal power required to perform these functions is 98 W (see Appendix I). This value was obtained by assuming a vehicle mass of 150 kg. To account for the power required by the targeting system, electronics, obstacle avoidance, and handling non-leveled terrain, the power requirement was doubled. Therefore overall device power was estimated to be 200 W.

6.4 System Design Summary

Table 1 presents a summary of the system parameters for the design of the regolith throwing device. The system designed consists of 10 units, each weighing approximately 150 kg. Each unit throws a cube of regolith 20 cm per side every 30 seconds. This allows for the task to be completed in a lunar day. Each unit moves at a velocity of 5 cm/sec gathering regolith at a depth of 5 cm per pass. The maximum throwing distance is 80 m. To obtain a maximum launch velocity of 12 m/s a spring with a maximum compression of 50 cm and a 6.75 kN/m spring constant is used.

Table 1
Summary of the System's Design Parameters

Number of Units	10
Mass of device	150 kg
System Mass	1500 kg
Volume of device	1 m ³
Device power requirements	200 W
Time to complete task	14 Earth-days
Habitat's Diameter	16 m
Total volume of regolith required	3140 m ³
Total Depth of Dig	0.2 m
No. of passes	4
Depth of regolith cleared per pass	0.05m
Volume of regolith per throw	20x20x20 cm ³
Cycle time	1 throw/30 sec
Launch velocity	12 m/sec
Rolling velocity	0.05 m/sec
Maximum throwing distance	80 m
Spring constant	6.75 kN/m
Maximum spring compression	0.5 m

CONCLUSIONS AND RECOMMENDATIONS FOR FUTURE WORK

The purpose of this project was to prove the feasibility of throwing as the regolith placement method for radiation shielding of lunar habitats and to conceptually design a mechanism to perform this task. Though this was accomplished, more work and analysis needs to be done in order to have a complete and thorough design. This section presents an evaluation of the design solution, outlines the next steps to be taken in the design process, and presents recommendations for other potential uses of this device.

7.1 Design Evaluation

The evaluation of the design chosen for the computer simulation shows two critical problems. The first problem is that the scraping method requires a high cutting force. Because the device is lightweight, the traction generated by the devices is small. The small traction makes effective scraping difficult to achieve.

The second problem with this configuration is that it has a tendency to tip. Appendix M contains the analysis of the stability of the device. The tendency to tip is caused by a number of factors including the high acceleration used to launch the regolith, the low device mass and the high launch position of the regolith with respect to the center of mass of the device. A supplemental report will be prepared to address the weaknesses of this device in a comprehensive manner.

7.2 Future Work

One of the next steps to be performed is to increase the detail of the design. Within each of the functions addressed, there are sets of subfunctions. For example, the linear throwing mechanism contains subsystems which were not addressed. One component of the throwing mechanism is a bin that holds and releases the volume of regolith. Other components are the track on which the regolith bin moves, the locking and release mechanisms for the bin, and the methods for changing the azimuthal and launch angles. Before beginning embodiment design, there are a number of potential areas that need to be researched more thoroughly to provide guidelines for design.

One of the problems encountered in the design of this device was in the investigation of regolith dispersion as it is thrown. Appendix E investigates the effects of dispersion caused by a rotational throwing motion. However, this analysis does not consider the effects of regolith adhesion to the throwing bin wall or potential problems from the non-homogeneity or looseness of the regolith. A volume of dirt disperses when it is thrown on the Earth, but it is unknown how regolith will behave when thrown on the Moon. The mechanics of throwing dirt were researched. No information was found about dirt throwing because throwing dirt has rarely been of interest on Earth. The design team believes that spreading of a thrown volume of dirt is essentially a function of atmosphere density, viscosity, cross-sectional area, and relative velocity between the atmosphere and the thrown volume. The Moon has no atmosphere and thus avoids

these problems. If the spreading of a thrown volume is significantly affected by other factors, such as the type of material thrown, throwing feasibility may be limited on the Moon. Before finalizing the design and constructing a regolith throwing device, the spreading mechanics of a thrown, particulate, non-solid volume need to be researched.

One of the initial design requests for this device was that it operate in an autonomous fashion. To achieve this, a critical function is obstacle identification and avoidance. A system was chosen to perform this function for each of the configurations presented. However, the chosen systems have several problems. An investigation into obstacle detection and avoidance systems for autonomous devices showed that this is an ongoing research area that has not yet achieved complete success. Optical identification systems have problems correctly identifying objects as significant hazards. Also, most successful systems use an ultrasonic sensor. Because the moon has no atmosphere an ultrasonic sensor will not work.

Even when using an accurate sensor, such as a mechanical bumper, problems remain with obstacle avoidance. The algorithms required to determine what to do when an obstacle is encountered are not effective in an unknown environment. Most research currently being done in obstacle detection and avoidance is for devices in a known world volume. A world volume is the space in which the device operates. The lunar surface presents an unknown world environment. Research needs to be done to provide an effective method of obstacle identification and avoidance for an autonomous lunar regolith throwing device.

7.3 Potential Device Applications

An impetus for furthering this design project is the versatility this device. A manned lunar base will require a number of operations which could be performed by this device. An effort must be made throughout the design process to achieve modularity and versatility. A fleet of autonomous devices could perform tasks before the lunar base is established and continue to be of use after astronauts occupy the base.

Incorporated into the design of this device must be an attempt to make it modular so that it may be used for other tasks. One potential use for these devices is to gather regolith for mineral extraction. Regolith contains oxygen and hydrogen. NASA intends to extract the oxygen and hydrogen from the regolith for lunar base use [50]. The regolith throwing devices could be easily modified to gather regolith and throw it into a bin for processing later. Although other methods have been proposed to gather and mine regolith for mineral extraction, modifying the regolith throwing device for this operation prevents the need of constructing and transporting another device to the Moon.

These devices could also be used for remote surveying of the lunar surface. Because of the automatic operation of these devices, little human operation will be required for this function. This will be of special advantage as it reduces expensive and dangerous EVA . In addition to remote sensing, these devices could be used as transportation modules to carry small items around the lunar base.

These devices could also be used to clear areas for lunar roadways. A previous study recommended that lunar roadways be constructed by

clearing the top surface of the lunar regolith and compacting the remaining surface [51]. These devices could be used to clear the roadway rather than transporting a specific device to the Moon for this purpose.

Although not addressed in this report, these devices could be modified to excavate craters. Craters will be dug on the lunar surface for the partial burial of lunar habitats and other lunar base buildings. These devices could be programmed to repeatedly clear a certain area of regolith, thus excavating a crater.

The regolith throwing devices could also be used to tow around large objects. The devices could be linked together in series, similar to locomotives towing railroad cars. This arrangement would allow the devices to haul an object too heavy for one device to haul by itself. This is an efficient method for towing loads. Because only the number of units necessary to haul a device will be used, no energy is wasted by having a large device haul a small load. If a modular arrangement is retained, a manipulator could be attached to the devices. This manipulator will allow the devices to load the bin before towing it and unload it once the bin has been towed to the desired location.

REFERENCES

1. Exploration Studies Technical Report, Volume III: Planetary Surface Systems, (The Office of Exploration, Johnson Space Center, Houston, TX: 1989), p. 2-4.
2. Exploration Studies Technical Report, Volume III: Planetary Surface Systems, (The Office of Exploration, Johnson Space Center, Houston, TX: 1989), p. 2-12.
3. Lunar Engineering Models: General and Site-Specific Data, (Lunar and Mars Exploration Program Office, Johnson Space Center, Houston, TX: 1991), p. 75.
4. Exploration Studies Technical Report, Volume III: Planetary Surface Systems, (The Office of Exploration, Johnson Space Center, Houston, TX: 1989), p. 5-42.
5. Exploration Studies Technical Report, Volume III: Planetary Surface Systems, (The Office of Exploration, Johnson Space Center, Houston, TX: 1989), p. 5-44.
6. Exploration Studies Technical Report, Volume III: Planetary Surface Systems, (The Office of Exploration, Johnson Space Center, Houston, TX: 1989), p. xviii
7. Exploration Studies Technical Report, Volume III: Planetary Surface Systems, (The Office of Exploration, Johnson Space Center, Houston, TX: 1989), p. 5-6
8. Heiken, G., Vaniman, D., French, B., Lunar Sourcebook, first edition (New York: Cambridge University Press, 1991). p56

9. Heiken, G., Vaniman, D., French, B., Lunar Sourcebook, first edition (New York: Cambridge University Press, 1991). p 56
10. Exploration Studies Technical Report, Volume III: Planetary Surface Systems, (The Office of Exploration, Johnson Space Center, Houston, TX: 1989), p.5-42
11. Exploration Studies Technical Report, Volume III: Planetary Surface Systems, (The Office of Exploration, Johnson Space Center, Houston, TX: 1989), p 5-43
12. Buoni, C., McCauley, L., Easler, D., Strohl, R., "Conceptual Design of a Vehicle to Construct a Lunar Very Low Frequency Array," (Battelle, Columbus, OH:1989), p. 15
13. Buoni, C., McCauley, L., Easler, D., Strohl, R., "Conceptual Design of a Vehicle to Construct a Lunar Very Low Frequency Array," (Battelle, Columbus, OH:1989), p. 15
14. Carrier, W., Mitchell, J., Mahmood, A., "The Nature of Lunar Soil", Journal of Soil Mechanics, (October 1973),p829
15. Heiken, G., Vaniman, D., French, B., Lunar Sourcebook, first edition (New York: Cambridge University Press, 1991). p34
16. Exploration Studies Technical Report, Volume III: Planetary Surface Systems, (The Office of Exploration, Johnson Space Center, Houston, TX: 1989), p.5-68.
17. Exploration Studies Technical Report, Volume III: Planetary Surface Systems, (The Office of Exploration, Johnson Space Center, Houston, TX: 1989), p. 5-68.

18. Banks, J., Efatpenah, K., Sines J. L., "Conceptual Design and Analysis of Road Construction Machinery for Initial Lunar Base Operations," (University of Texas at Austin: Austin, TX, 1990), p. 32.
19. Exploration Studies Technical Report, Volume III: Planetary Surface Systems, (The Office of Exploration, Johnson Space Center, Houston, TX: 1989), p. 5-69.
20. Banks, J., Efatpenah, K., Sines J. L., "Conceptual Design and Analysis of road Construction Machinery for Initial Lunar Base Operations," (University of Texas at Austin: Austin, TX, 1990), p. 33.
21. Banks, J., Efatpenah, K., Sines J. L., "Conceptual Design and Analysis of road Construction Machinery for Initial Lunar Base Operations," (University of Texas at Austin: Austin, TX, 1990), p. 38
22. Buoni, C., McCauley, L., Easler, D., Strohl, R., "Conceptual Design of a Vehicle to Construct a Lunar Very Low Frequency Array," (Battelle, Columbus, OH:1989), p. 64.
23. Buoni, C., McCauley, L., Easler, D., Strohl, R., "Conceptual Design of a Vehicle to Construct a Lunar Very Low Frequency Array," (Battelle, Columbus, OH:1989), p. 32.
24. Buoni, C., McCauley, L., Easler, D., Strohl, R., "Conceptual Design of a Vehicle to Construct a Lunar Very Low Frequency Array," (Battelle, Columbus, OH:1989), p. 40.
25. Buoni, C., McCauley, L., Easler, D., Strohl, R., "Conceptual Design of a Vehicle to Construct a Lunar Very Low Frequency Array," (Battelle, Columbus, OH:1989), pp. 36-37.
26. Buoni, C., McCauley, L., Easler, D., Strohl, R., "Conceptual Design of a Vehicle to Construct a Lunar Very Low Frequency Array," (Battelle, Columbus, OH:1989), p 37

27. Hovanessian, S.A., Radar System Design and Analysis, (Artech House, Inc.,Dedham, MA:1984), p. 133.
28. Buoni, C., McCauley, L., Easler, D., Strohl, R., "Conceptual Design of a Vehicle to Construct a Lunar Very Low Frequency Array," (Battelle, Columbus, OH:1989), p. 31.
29. Buoni, C., McCauley, L., Easler, D., Strohl, R., "Conceptual Design of a Vehicle to Construct a Lunar Very Low Frequency Array," (Battelle, Columbus, OH:1989), p. 36.
30. Buoni, C., McCauley, L., Easler, D., Strohl, R., "Conceptual Design of a Vehicle to Construct a Lunar Very Low Frequency Array," (Battelle, Columbus, OH:1989), p. 82.
31. Avallone, E. A., Baumeister III, T., Mark's Standard Handbook for Mechanical Engineers: Ninth Edition, (McGraw-Hill, New York: 1987), p. 9-164.
32. Buoni, C., McCauley, L., Easler, D., Strohl, R., "Conceptual Design of a Vehicle to Construct a Lunar Very Low Frequency Array," (Battelle, Columbus, OH:1989), p. 85.
33. Buoni, C., McCauley, L., Easler, D., Strohl, R., "Conceptual Design of a Vehicle to Construct a Lunar Very Low Frequency Array," (Battelle, Columbus, OH:1989), p. 83.
34. Buoni, C., McCauley, L., Easler, D., Strohl, R., "Conceptual Design of a Vehicle to Construct a Lunar Very Low Frequency Array," (Battelle, Columbus, OH:1989), p. 83.
35. Exploration Studies Technical Report, Volume III: Planetary Surface Systems, (The Office of Exploration, Johnson Space Center, Houston, TX: 1989), p. 5-48.

36. Buoni, C., McCauley, L., Easler, D., Strohl, R., "Conceptual Design of a Vehicle to Construct a Lunar Very Low Frequency Array," (Battelle, Columbus, OH:1989), p. 79.
37. Buoni, C., McCauley, L., Easler, D., Strohl, R., "Conceptual Design of a Vehicle to Construct a Lunar Very Low Frequency Array," (Battelle, Columbus, OH:1989), pp. 79-81.
38. Buoni, C., McCauley, L., Easler, D., Strohl, R., "Conceptual Design of a Vehicle to Construct a Lunar Very Low Frequency Array," (Battelle, Columbus, OH:1989), p. 77.
39. Buoni, C., McCauley, L., Easler, D., Strohl, R., "Conceptual Design of a Vehicle to Construct a Lunar Very Low Frequency Array," (Battelle, Columbus, OH:1989), p. 46.
40. Exploration Studies Technical Report, Volume III: Planetary Surface Systems, (The Office of Exploration, Johnson Space Center, Houston, TX: 1989), p. 5-38.
41. Detwiler, M., Foong, C.S., Stocklin, C., "Conceptual Design of Equipment to Excavate and Transport Regolith From the Lunar Maria Final Design Report," (University of Texas at Austin, Austin, TX: 1990), p. 57-58.
42. Exploration Studies Technical Report, Volume III: Planetary Surface Systems, (The Office of Exploration, Johnson Space Center, Houston, TX: 1989), p. 5-105.
43. Belden, L., et. al., "Design of Equipment for Lunar Dust Removal," (University of Texas at Austin, Austin, TX: 1991), p. 23.

44. Exploration Studies Technical Report, Volume III: Planetary Surface Systems, (The Office of Exploration, Johnson Space Center, Houston, TX: 1989), p. 5-92
45. Buoni, C., McCauley, L., Easler, D., Strohl, R., "Conceptual Design of a Vehicle to Construct a Lunar Very Low Frequency Array," (Battelle, Columbus, OH:1989), p. 79
46. Belden, L., et. al., "Design of Equipment for Lunar Dust Removal," (University of Texas at Austin, Austin, TX: 1991), p. 23.
47. Buoni, C., McCauley, L., Easler, D., Strohl, R., "Conceptual Design of a Vehicle to Construct a Lunar Very Low Frequency Array," (Battelle, Columbus, OH:1989), p. 37
48. Buoni, C., McCauley, L., Easler, D., Strohl, R., "Conceptual Design of a Vehicle to Construct a Lunar Very Low Frequency Array," (Battelle, Columbus, OH:1989), p. 69
49. Heiken, G., Vaniman, D., French, B., Lunar Sourcebook, first edition (New York: Cambridge University Press, 1991). p26
50. Exploration Studies Technical Report, Volume III: Planetary Surface Systems, (The Office of Exploration, Johnson Space Center, Houston, TX: 1989), p. 2-12.
51. Banks, J., Efatpenah, K., Sines J. L., "Conceptual Design and Analysis of road Construction Machinery for Initial Lunar Base Operations," (University of Texas at Austin: Austin, TX, 1990)

APPENDICES

APPENDIX A

Function Structure for a Fleet of Devices to Cover Lunar Habitats

This appendix shows a process description for the functions each device will perform to complete the task it is to perform. The functional description is general: details how each process is to be performed are not presented.

The organization of the function structure is as follows. The outer dashed line represents the system boundary. The flow of materials, signals, and energy into and out of the system is shown. Included in Figure A1 is a key to differentiate between the flows of materials, signals, and energy.

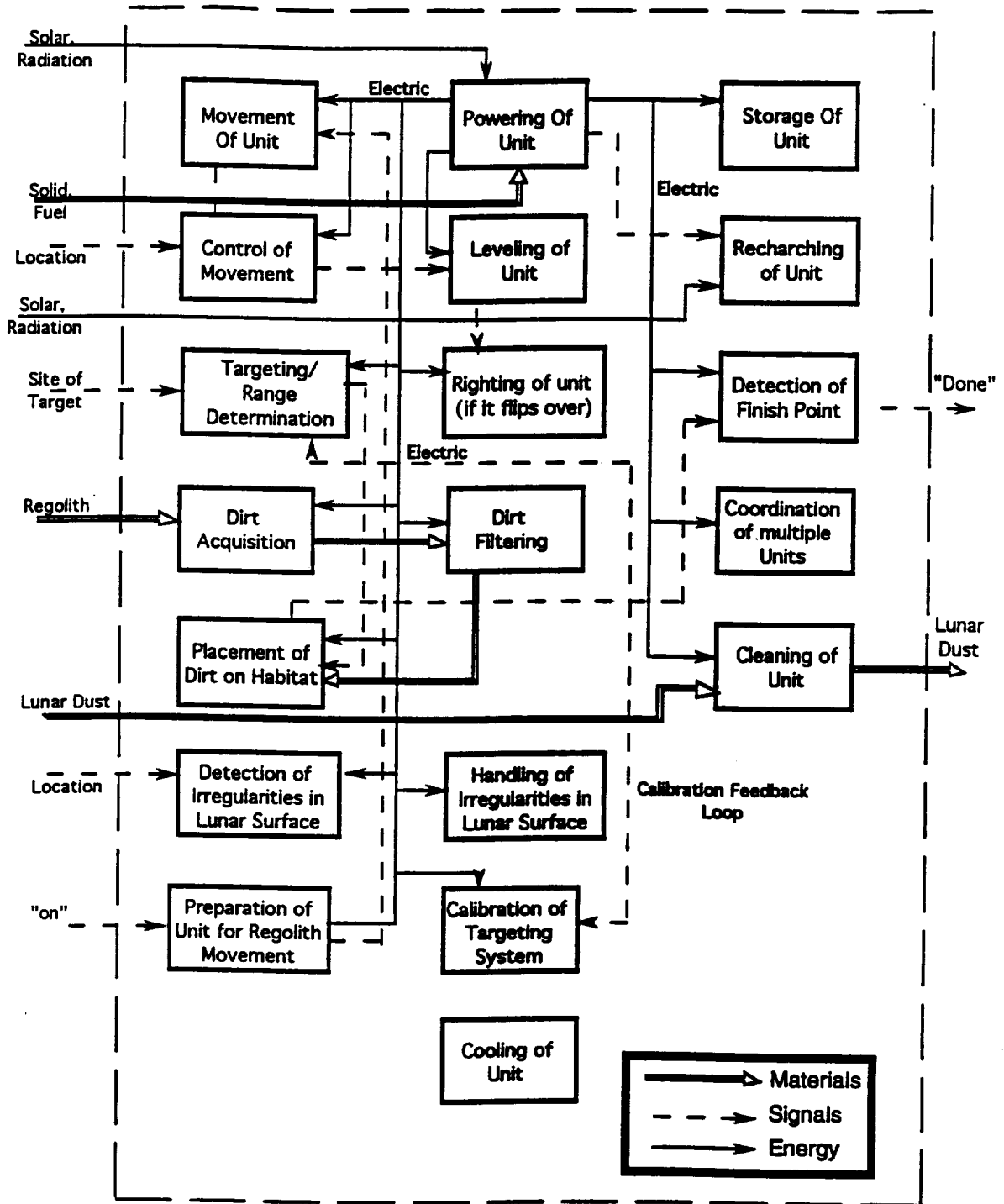

Figure A1. Function Structure of Lunar Device.

APPENDIX B

Effects of Regolith Impact and Placement on Habitat

This appendix addresses the potential effects a load of regolith will have when impacting a lunar habitat. Plots of impact force and impact stress versus impact duration were generated. Two typical impact durations are 1.2 ms for a baseball and bat, and 4 ms for a tennis racket and ball. A baseball and bat collision is fairly inelastic while a tennis racket and ball collision is fairly elastic. The regolith impact should fall easily in this range.

A proposed material for strengthening of the habitat skin is Kevlar. By comparing the yield strength of Kevlar to the impact stresses from the plot, it can be seen that there is little danger of a thrown load of regolith penetrating the habitat. Better materials information is needed for a more accurate analysis. Specifically, the exact material for the habitat skin needs to be known.

This appendix also calculates an approximate stress the habitat must support when covered by regolith. A potential problem with using regolith as radiation shielding is the stress it may put on the habitat. The calculation done presents limited accuracy, but, because the stress proved small ($P=8.44$ kPa), a more accurate analysis was not performed.

IMPACT OF REGOLITH LOAD ON HABITAT

IMPULSE-MOMENTUM THEOREM

$$\vec{J} = \vec{P}_f - \vec{P}_i \quad [\text{kg} \cdot \text{m/s}]$$

$\vec{J} \sim$ IMPULSE

$\vec{P}_f \sim$ FINAL MOMENTUM

$\vec{P}_i \sim$ INITIAL MOMENTUM

$$\therefore \vec{J} = m(\vec{U}_f - \vec{U}_i)$$

$$\vec{U}_f = 0 \quad [\text{IMPACTED HABITAT}]$$

$$\therefore \vec{J} = -m\vec{U}_i = \vec{F} \Delta t$$

$$\rightarrow \boxed{\vec{F} = \frac{mU_i}{\Delta t}} \quad [\text{N}] \quad (\text{B1})$$

$\vec{F} \sim$ AVERAGE FORCE OF IMPACT

$\Delta t \sim$ DURATION OF IMPACT

IMPACT STRESS

$$S \approx \frac{\vec{F}}{A}$$

WHERE $A = x^2$ (B2)

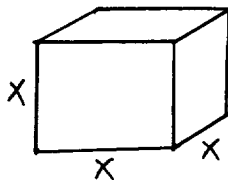

← CUBIC LOAD
OF REGOLITH

CUBE ASSUMED, FOR SIMPLICITY.

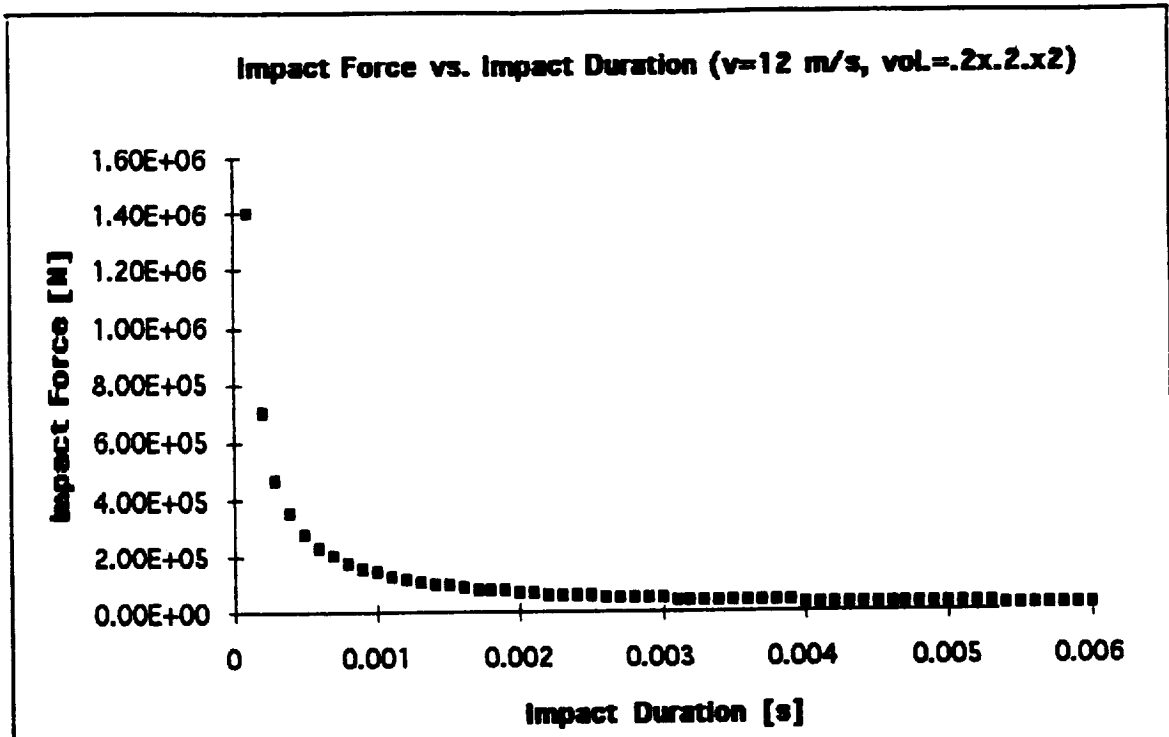

Figure B1. Impact force vs. Impact duration (Equation B1)

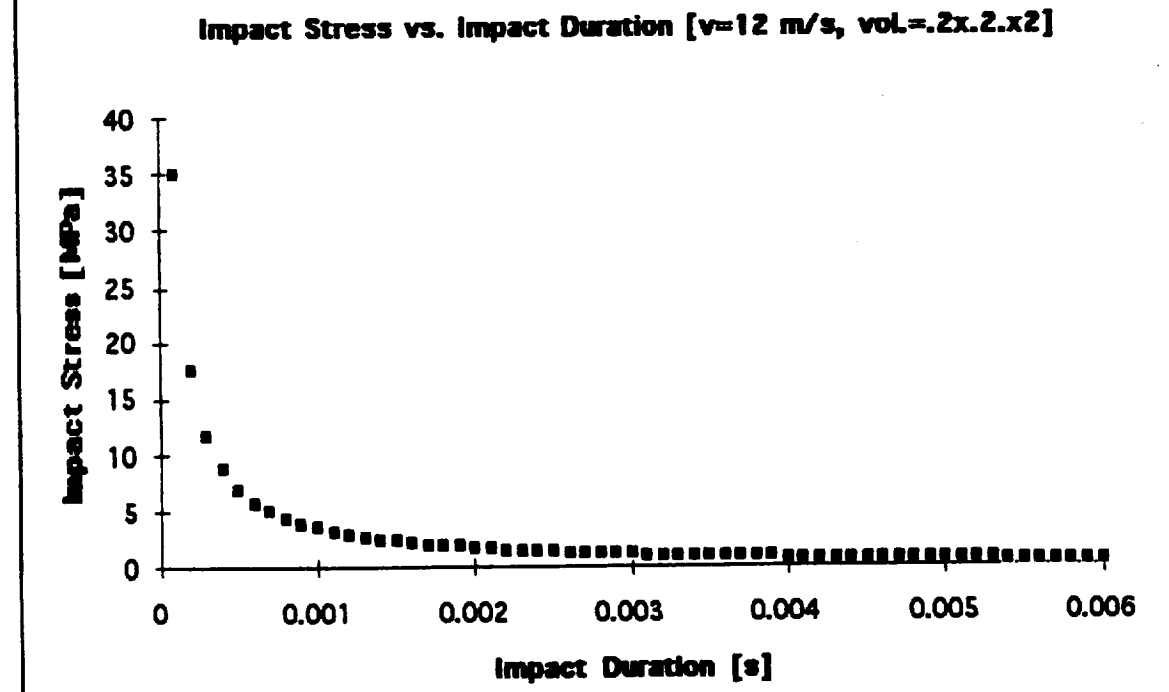

Figure B2. Impact Stress vs. Impact duration (Equation B2)

PLOTS WERE MADE WITH THESE VALUES:

VELOCITY = 12 m/s

X = 0.2 m

DENSITY OF REGOLITH = 1465 kg/m³

TYPICAL IMPACT DURATIONS:

BASEBALL AND BAT $\Delta t \sim 1.2$ ms

TENNIS RACKET & BALL $\Delta t \sim 4$ ms

THE FIRST IS FAIRLY INELASTIC, AND
THE SECOND IS A FAIRLY ELASTIC IMPACT.
THE IMPACT OF THE REGOLITH WITH THE
HABITAT SHOULD HAVE AN IMPACT DURATION
SOMEWHERE BETWEEN THE TWO ABOVE.

ONE MATERIAL PROJECTED FOR USE IN
HABITAT SKIN, FOR STRENGTH, IS KEVLAR.
KEVLAR HAS A YIELD STRENGTH OF
3617 MPa, IN TENSION. THIS VALUE
IS OFF THE SCALE ON THE PLOTS.

∴ THERE SHOULD BE NO DANGER OF
PENETRATING THE LUNAR HABITAT
WITH A LOAD OF REGOLITH.

MORE DETAILED ANALYSIS IS NEEDED
FOR A HIGHER LEVEL OF CERTAINTY
AND ACCURACY.

Assumptions:

- 1) The approximate stress put on the habitat by the regolith is F/A where A is the cross sectional area supporting the load.

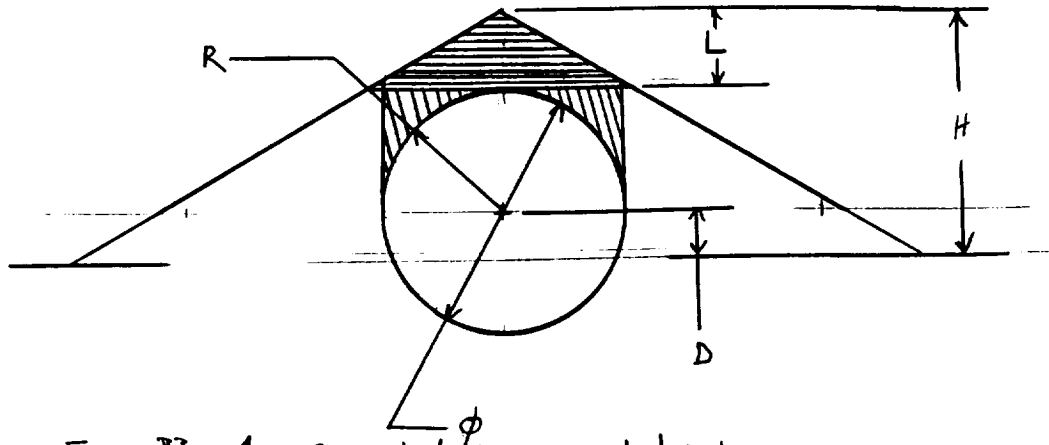

Figure B3. Area causing load stress on habitat

Nomenclature:

L = height of cone above sphere

R = radius of habitat

ϕ = diameter of habitat.

D = distance center of habitat is above ground zero

V = Volume of regolith in shaded region.

P = stress on habitat

ρ = regolith density

g = acceleration due to gravity

H = Height of cone

Methodology:

First calculate the approximate volume of regolith the habitat must support, as shown in the shaded area of Figure B3. The approximate the pressure this exerts on the habitat.

Analysis:

$$L = H - (\phi - D) \quad (B3)$$

$$V = \frac{1}{3}\pi R^3 L + \pi R^3 - (\frac{4}{3}\pi R^3)/2 \quad (B4)$$

$$A = \frac{\pi}{4} D^2 \quad (B5)$$

$$P = \rho V g / A \quad (B6)$$

Conclusions:

Using values of:

$$H = 13.8 \text{ m}$$

$$R = 8 \text{ m}$$

$$H = 3.123 \text{ m}$$

$$\rho = 1465 \text{ kg/m}^3$$

$$g = 1.624 \text{ m/s}^2$$

yields a stress of

$$P = 8.44 \text{ kPa}$$

The habitat should be able to support a stress of 8.44 kPa.

APPENDIX C

Comparison of Projectile Motion on the Earth and the Moon

A comparison of projectile motion on the Earth and on the Moon was made in this appendix. Projectile motion on the Earth includes aerodynamic drag and a higher gravity. The throwing of regolith on the Earth will also include a degree of dispersion of the load, due to the atmosphere. This dispersion will not be seen on the Moon because of the near total vacuum there. Due to lack of information on the spreading of thrown regolith, this dispersion effect was assumed to be negligible.

This analysis shows that projectile motion on the Moon provides significant energy savings. For a given launch velocity, a projectile can travel a great deal further on the Moon. For a launch velocity of 12 m/s and a regolith load of 11.72 kg, the load will travel approximately five times further on the Moon than on the Earth. In addition, this appendix presents a plot displaying the affect of launch angle on projectile trajectory.

COMPARISON OF TRAJECTORY ON MOON AND TRAJECTORY ON EARTH

LUNAR - NO AERODYNAMIC DRAG SINCE NO ATMOSPHERE. \therefore PARABOLIC MOTION.

$$y = x \tan \theta - x^2 \left(\frac{g_L}{2 (u_0 \cos \theta)^2} \right) \quad (C1)$$

$$g_L \sim \text{LUNAR GRAVITY} \\ = \frac{1}{6} g = 1.6344 \text{ m/s}^2$$

$u_0 \sim$ INITIAL LAUNCH VELOCITY

$\theta \sim$ INITIAL LAUNCH ANGLE

EARTH - APPROXIMATELY PARABOLIC, BUT DRAG (FROM ATMOSPHERE) ALSO INVOLVED.

$$\text{DRAG FORCE, } D = \frac{1}{2} C \rho A u^2 \leftarrow \text{VALID FOR LARGE } Re$$

$C \sim$ DRAG COEFFICIENT

$\rho \sim$ DENSITY OF AIR
 $\approx 1.21 \text{ kg/m}^3$

$A \sim$ CROSS-SECTIONAL AREA OF PROJECTILE.

$u \sim$ VELOCITY

IF $m =$ MASS LAUNCHED,

$$D = m a_D \rightarrow a_D = \frac{D}{m} \sim \text{DECELERATION FROM DRAG FORCE.}$$

REYNOLDS #: $Re = \frac{\rho U d}{\nu}$

ρ ~ FLUID DENSITY (AIR)

U ~ VELOCITY

d ~ CROSS-SECTIONAL AREA OF PROJECTILE

ν ~ VISCOSITY OF FLUID (AIR)

$$= 1.79 \times 10^{-5} \text{ N}\cdot\text{s}/\text{m}^2$$

ASSUMES: TURBULENCE BEHIND MOVING BODY,
i.e. BOUNDARY LAYERS ARE TRIPPED.

IF $Re \lesssim 1$ (i.e. VERY SMALL) - VISCOUS
DRAG PREDOMINATES

IF Re LARGE - FORM RESISTANCE (PRESSURE
RESISTANCE) DOMINATES.

IF LET $d = 0.3 \times 0.3 = 0.09 \text{ m}^2$
 $U = 25 \text{ m/s}$

$$\rightarrow Re = 1.52 \times 10^5$$

$\therefore Re$ LARGE ENOUGH SO EQUATION FOR
 D APPLIES.

DECELERATION FROM AIR DRAG:

$$a_D = \frac{D}{m} = \frac{C_D A U^2}{2m}$$

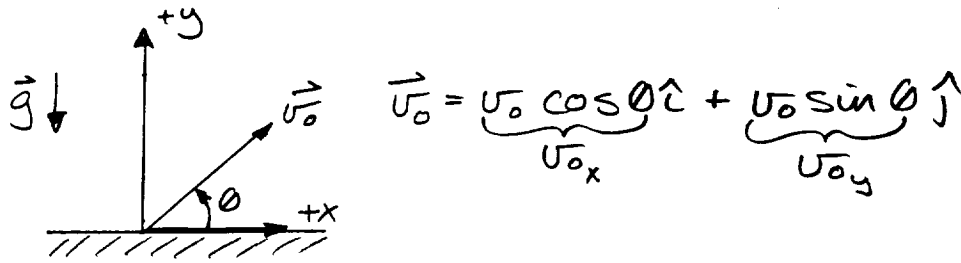

$$\vec{v}_0 = \underbrace{v_0 \cos \theta}_{v_{0x}} \hat{i} + \underbrace{v_0 \sin \theta}_{v_{0y}} \hat{j}$$

X-MOTION

IF $\vec{v}_{0x} = v_{0x} \hat{i}$; $\vec{a}_D = -a_D \hat{i}$

$v dv = a ds$ $a = -Kv^2$; $K = C\rho A/2m$
 $v_x dv_x = -Kv_x^2 ds_x$

$$\int_0^{v_x} \frac{1}{v_x'} dv_x' = \int_0^{s_x} -K ds_x'$$

$e^{(\ln v_x - \ln v_{0x} = -Ks_x)} \rightarrow e^{\ln v_x} \cdot e^{-\ln v_{0x}} = e^{-Ks_x}$

$v_x \cdot (v_{0x})^{-1} = e^{-Ks_x}$

$v_x = v_{0x} e^{-Ks_x}$

SINCE $v_x = \frac{ds_x}{dt} \rightarrow ds_x = v_{0x} e^{-Ks_x} dt$

$\int e^{Ks_x} ds_x = \int v_{0x} dt \leftarrow v_{0x} \neq v_{0x}(t)$

$\frac{1}{K} e^{Ks_x} = v_{0x} t + C$

AT $t=0, s_x=0$

$\therefore C = 1/K$

$$e^{Ks_x} = K(u_{0x} t + C)$$

$$\underline{S_x = \frac{1}{K} \ln(Ku_{0x} t + 1)} \quad \text{WHERE } K = \frac{C_p A}{2m} (C2)$$

NEED $y = y(t)$ AND THEN FIND $y = y(x)$
Y-MOTION

$$a_y = -g - a_{Dy}$$

$$a = a(v) \rightarrow t = \int_0^t dt = \int_{u_{0y}}^{u_y} \frac{du_y'}{a(u_y')}$$

$$\text{WHERE: } a(u_y') = -g - K u_y'^2$$

$$\& K = C_p A / 2m$$

$$t = - \int_{u_{0y}}^{u_y} \frac{du'}{K \left(\frac{-g + K u'^2}{K} \right)} = -\frac{1}{K} \int_{u_{0y}}^{u_y} \frac{du'}{(u')^2 + g/K}$$

FROM INTEGRAL TABLES:

$$\int \frac{dx}{a^2 + x^2} = \frac{1}{a} \tan^{-1} \frac{x}{a} ; \quad x \rightarrow u' \quad a \rightarrow \pm \sqrt{g/K} \leftarrow \text{ONLY}$$

INTERESTED IN
POSITIVE VALUE

$$\therefore t = -\frac{1}{K} \left\{ \sqrt{\frac{K}{g}} \tan^{-1} \sqrt{\frac{K}{g}} u' \right\} \Big|_{u_{0y}}^{u_y}$$

$$t = -\sqrt{\frac{1}{Kg}} \left\{ \tan^{-1} \left(\sqrt{\frac{K}{g}} u_y \right) - \underbrace{\tan^{-1} \left(\sqrt{\frac{K}{g}} u_{0y} \right)}_{\text{CONSTANT}} \right\}$$

$$\text{LET: } M = \tan^{-1} \left(\sqrt{\frac{K}{g}} u_{0y} \right)$$

$$-\sqrt{Kg}t + M = \tan^{-1}\left(\sqrt{\frac{K}{g}}u_y\right)$$

$$\sqrt{\frac{K}{g}}u_y = \tan^{-1}\left[-\sqrt{Kg}t + M\right]$$

$$u_y = \sqrt{\frac{g}{K}} \tan^{-1}\left[-\sqrt{Kg}t + M\right]$$

$$\text{WHERE } M = \tan^{-1}\left(\sqrt{\frac{K}{g}}u_{0y}\right)$$

$$\frac{ds_y}{dt} = \sqrt{\frac{g}{K}} \tan^{-1}\left[-\sqrt{Kg}t + M\right]$$

INTEGRATED W/ MATHEMATICA...

$$s_y = \frac{M \tan^{-1}(M)}{K} - \frac{(M - g^{1/2} K^{1/2} t)}{K} \tan^{-1}\left[M - g^{1/2} K^{1/2} t\right] \\ - \frac{0.5 \ln[1 + M^2]}{K} + \frac{0.5 \ln[1 + (M - g^{1/2} K^{1/2} t)^2]}{K} + C$$

$$\text{AT } t=0; s_y=0$$

$$\therefore C=0$$

$$\therefore s_y(t) = \frac{M}{K} \left(\sqrt{\frac{K}{g}}u_{0y}\right) - \frac{(M - g^{1/2} K^{1/2} t)}{K} \tan^{-1}\left[M - g^{1/2} K^{1/2} t\right] \\ - \frac{0.5}{K} \ln[1 + M^2] + \frac{0.5}{K} \ln[1 + (M - g^{1/2} K^{1/2} t)^2]$$

$$M = \tan^{-1}\left(\sqrt{\frac{K}{g}}u_{0y}\right) \quad (C3)$$

$$K = C_p A / 2m$$

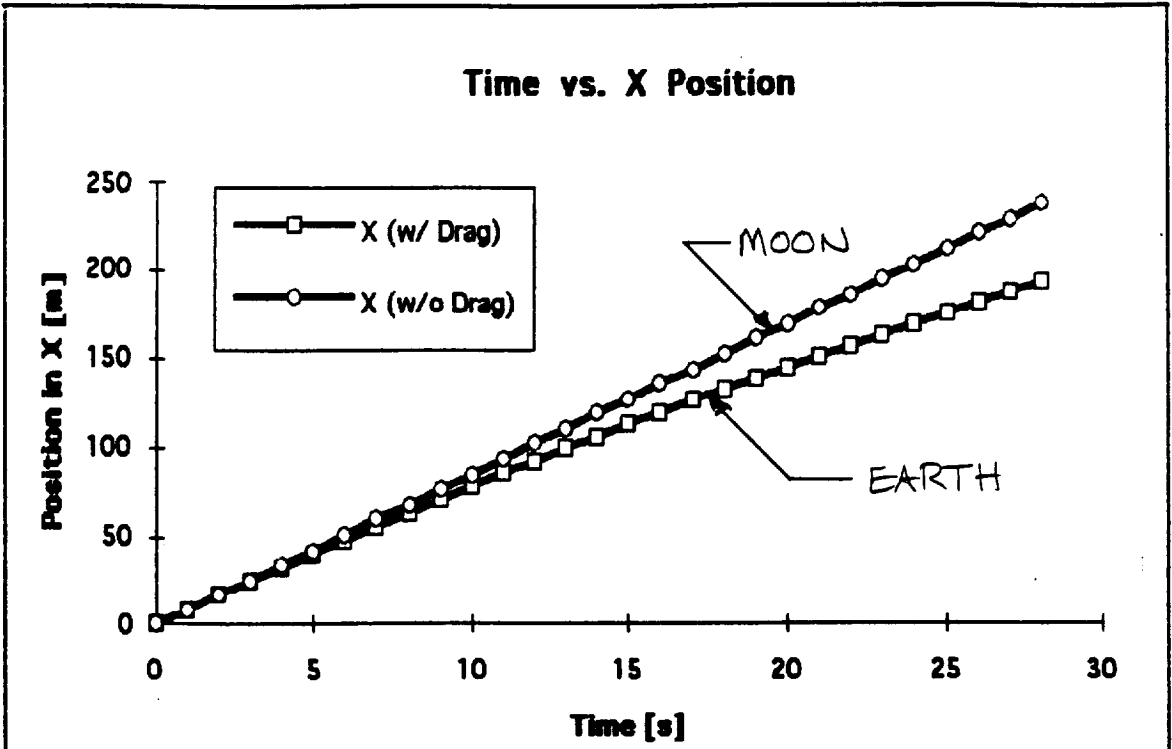

FIGURE C1. Horizontal position vs time (plot of Equation C2).

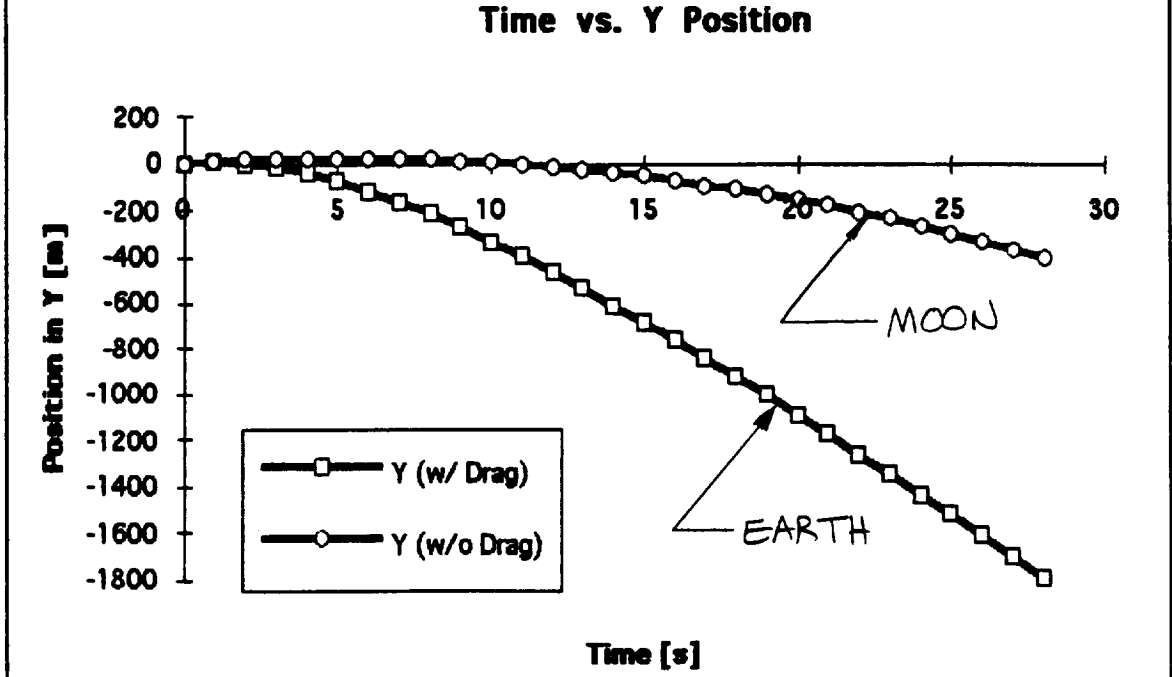

FIGURE C2. Vertical position vs. time (Equation C3)

THE ABOVE PLOTS WERE MADE ASSUMING:
 - 0.2m x 0.2m x 0.2m CUBE OF REGOLITH
 - MASS OF REGOLITH = 11.72 kg
 - LAUNCH VELOCITY = 12 m/s

NOW, NEED $y = y(x)$, FOR DRAG.
 FROM EQUATION (C2),

$$Kx = \ln(KU_{0x}t + 1) \rightarrow e^{Kx} = KU_{0x}t + 1$$

$$e^{Kx} - 1 = KU_{0x}t$$

$$t = \frac{e^{Kx} - 1}{KU_{0x}}$$

NOW SUBSTITUTE FOR t IN EQUATION (C3)

$$y = \frac{M}{K} \tan^{-1}(M) - \left[\frac{(M - g^{1/2} K^{1/2} \left(\frac{e^{Kx} - 1}{KU_{0x}} \right))}{K} \right] \downarrow$$

$$\cdot \tan^{-1} \left(M - g^{1/2} K^{1/2} \left(\frac{e^{Kx} - 1}{KU_{0x}} \right) \right) \downarrow$$

$$- \frac{0.5}{K} \ln[1 + M^2] \downarrow$$

$$+ \frac{0.5}{K} \ln \left(1 + \left(M - g^{1/2} K^{1/2} \left(\frac{e^{Kx} - 1}{KU_{0x}} \right) \right)^2 \right) \quad (C4)$$

$$M = \tan^{-1} \left\{ \sqrt{\frac{K}{g}} U_{0y} \right\}$$

$$K = C_p A / 2m$$

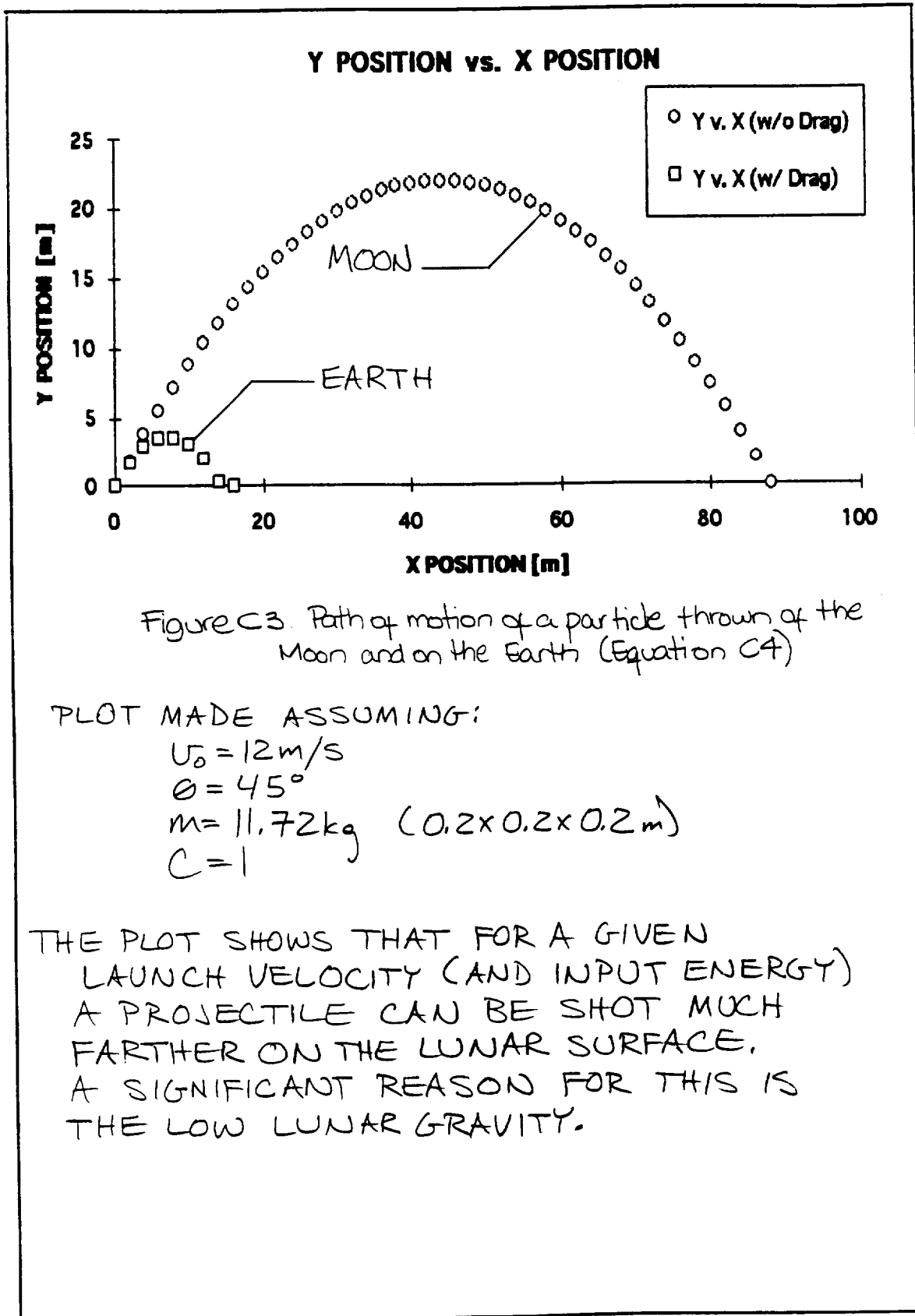

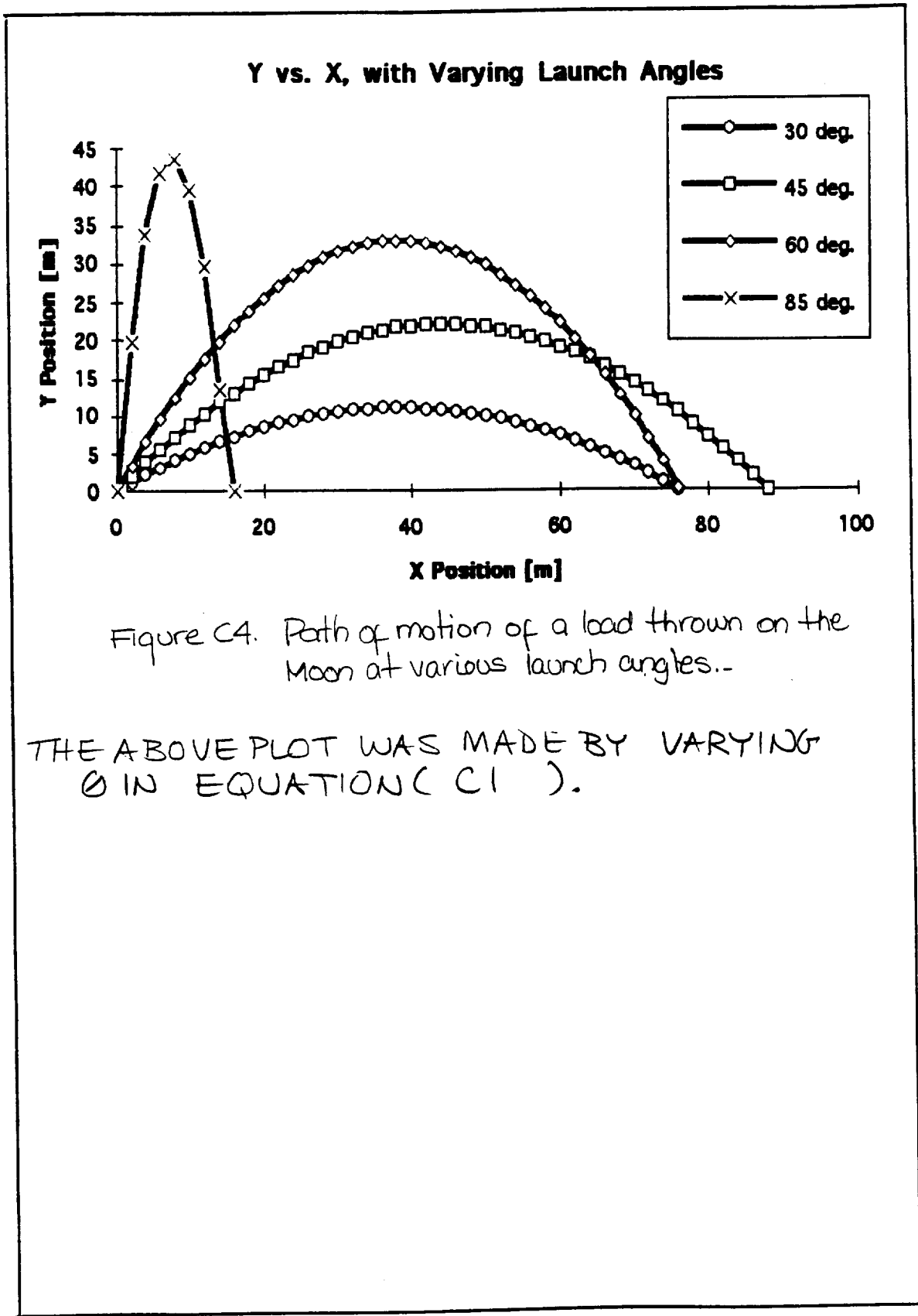

APPENDIX D

Comparison of Carrying Work and Throwing Work

This appendix presents a detailed analysis of the work comparison between the methods of carrying and throwing the regolith. Derivations of equations are presented followed by computer programs used to solve the equations for the information desired. Lastly, several graphs are presented using the results of the programs. Using the information provided by these graphs, it can be seen that throwing proves a superior solution for regolith movement on the moon. Also, based on the information in Figure D4, the dig depth was chosen to be 0.2m.

In the derivation of the energy requirements, the energy required to gather the regolith was neglected. It was assumed that the energy required to gather the regolith would be approximately the same for both methods. Therefore, knowledge of the energy required to gather the regolith is unnecessary to compare the two alternatives.

Lastly, as a means of comparison, typical Earth-based dirt moving technologies were examined. A conveyor belt and a bucket assembly are two such methods to move soil. As is seen in this appendix, a problem with these methods is their overall size. The expense of transporting large structures to the lunar surface can be enormous. Another problem with these methods is their lack of redundancy. To achieve any redundancy with these methods, often more than one system is required.

Assumptions:

- 1) The device clears the regolith in a circular area around the habitat.
- 2) The regolith is of constant density
- 3) The device gathers the regolith at a constant depth.

Nomenclature:

- V_r = velocity that regolith is launched at
 S = distance regolith must be thrown
 t_r = depth of dig
 ρ = density of regolith
 $\#$ = volume of regolith thrown
 θ_0 = angle the regolith is thrown at.

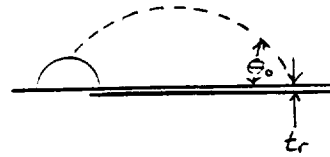
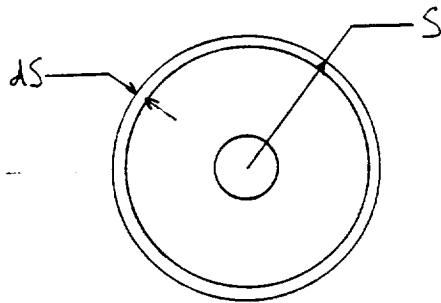

Methodology:

- Use a work energy approach.
Integrate the energy required to throw a differential volume regolith over the entire area cleared.

$$\text{Energy} = \int dE \quad (D1)$$

$$E = \frac{1}{2} \rho \dot{\theta} V_0^2; \quad dE = \frac{1}{2} \rho V_0^2 d\dot{\theta}$$

$$d\dot{\theta} = \tau r 2\pi S dS \quad (D2)$$

$$dE = \frac{1}{2} \rho V_0^2 \tau r 2\pi S dS \quad (D3)$$

V_0 is a function of S . V_0 must be derived in terms of S , $V_0(S)$, in order to perform the integral in (D1).

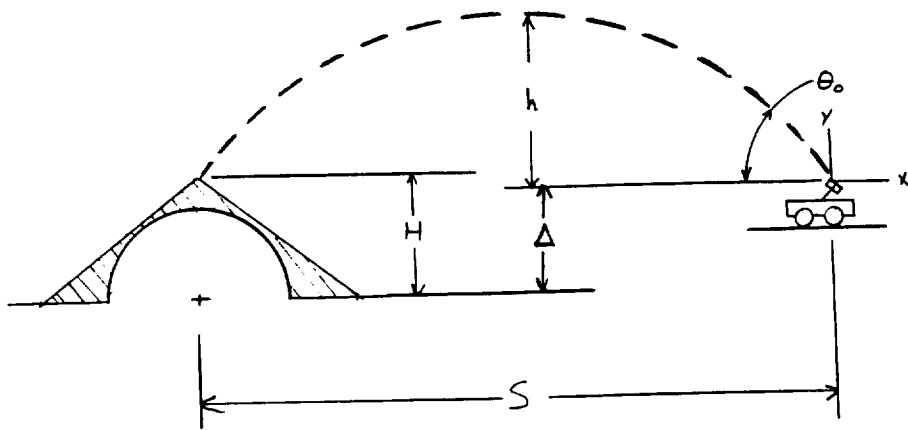

Additional Nomenclature:

H = height above ground zero at which the regolith must land

h = height regolith travels above the position it is thrown from

Δ = height above ground zero from which it is thrown.

Methodology:

First, calculate the time it spends above ground zero. Then calculate the distance it travels horizontally in that time.

Analysis:

$$\text{time up} = v_{y0}/g$$

$$\text{time down} = \sqrt{\frac{2(h+\Delta-H)}{g}}$$

$$\text{time} = \frac{v_{y0}}{g} + \sqrt{\frac{2(h+\Delta-H)}{g}}$$

$$S = v_x \cdot \text{time} = v_x \left[\frac{v_{y0}}{g} + \sqrt{\frac{2(h+\Delta-H)}{g}} \right] \quad (D4)$$

$$h = v_{y0}(\text{time up}) - \frac{1}{2}g(\text{time up})^2$$

$$h = \frac{v_{y0}^2}{g} - \frac{1}{2}g\left(\frac{v_{y0}}{g}\right)^2 = \frac{v_{y0}^2}{2g} \quad (D5)$$

also

$$v_{y0} = v_0 \sin \theta_0 \quad (D6)$$

$$v_{x0} = v_0 \cos \theta_0 \quad (D7)$$

Substitute (D5), (D6), and (D7) into (D4) gives,

$$S = v_0 \cos \theta_0 \left\{ \frac{v_0 \sin \theta_0}{g} + \left[\frac{2}{g} \left(\frac{v_0^2 \sin^2 \theta_0}{2g} + \Delta - H \right) \right]^{1/2} \right\} \quad (D8)$$

where g = acceleration due to gravity
and the rest of the variables are as defined before.

$$E = \int \frac{1}{2} \rho (V_0(s))^2 r 2\pi S ds \quad (D9)$$

where V_0 is solved using a numerical solution
to equation (D8).

The following program solves the energy integral
in equation (D9). Different parameters were
changed during the design process to process different
data. Data generated by the program integral are plot
in Figure D3, Figure D4 and Figure D5, which are found
in pages D20 & D21.

PROGRAM INTEGR1

```
C THIS PROGRAM INTEGRATES THE WORK REQUIRED TO COVER THE HABITAT
C WITH REGOLITH. THE MAIN PROGRAM WILL CALCULATE THE VOLUME AND
C OTHER INFORMATION BASED ON CRITICAL INPUT VALUES. AT THIS POINT
C CRITICAL INPUT VALUES WILL BE ENTERED MANUALLY IN THE SOURCE CODE.
C AT A LATER DATE, THE PROGRAM MAY BE MODIFIED TO ACCEPT A USER
C CREATED INPUT FILE.
C ****USER SPECIFIED VALUES
C G=GRAVITY ON THE MOON
C TR=THICKNESS OF REGOLITH SCOOPED, M
C THETA=LAUNCH ANGLE, RAD
C H=HEIGHT OF HABITAT, M
C R=RADIUS OF HABITAT, M
C T=THICKNESS OF REGOLITH ON TOP OF HABITAT, M
C ANOT=ANGLE OF REPOSE FOR REGOLITH, RAD
C N=NUMBER OF STEPS IN INTEGRATION, N MUST BE EVEN
C RHO=DENSITY OF REGOLITH, KG/M/M/M
C DELT=HEIGHT FROM WHICH DEVICE THROWS, M
C PI=3.141592654
C D=DISTANCE FROM CENTER OF HABITAT TO GROUND ZERO, M
C **** CALCULATED AND USED VARIABLES ****
C VOL=VOLUME OF REGOLITH REQUIRED TO COVER HABITAT, M^3
C STEP=STEP SIZE OF INTEGRATION
C SMAX=MAXIMUM DISTANCE FROM WHICH THE DEVICE THROWS, M
C SUM1=SUMMATION OF PART OF INTEGRAL
C SUM2=SUMMATION OF PART OF INTEGRAL
C FNOT=DWORK SOLUTION FOR FIRST STEP, S=B
C FN=DWORK SOLUTION FOR LAST STEP, S=SMAX
C I=STEP COUNTER
C **** DECLARE AND TYPE VARIABLES ****
REAL B,R,T,ANOT,D,H,VOL,PI,TR,SMAX,STEP,SUM1,SUM2,FNOT,FN,RHO
REAL DELT,THETA,INT,G
INTEGER N,I
C **** SET UP INPUT AND OUTPUT FILES ****
C INPUT FILE
C NONE
C OUTPUT FILES
C FILE FOR WORK VALUE
OPEN(UNIT=2,FILE='INTEGRW.OUT')
C FILE FOR SMAX VALUE
OPEN(UNIT=3,FILE='INTEGRS.OUT')
C FILE FOR TR VALUE
OPEN(UNIT=4,FILE='INTEGRT.OUT')
C FILE FOR VELOCITY
OPEN(UNIT=5,FILE='INTEGRV.OUT')
C FILE FOR S, DISTANCE
OPEN(UNIT=6,FILE='DIST.OUT')
OPEN(UNIT=10,FILE='VNAUGHT.OUT')
OPEN(UNIT=11,FILE='S.OUT')
C **** ENTER USER VALUES ****
PI=3.141592654
G=1.624
```

```

ANOT=37.*PI/180.
T=.5
R=8.
DELT=0.0
TR=.1
N=100
THETA=45.*PI/180.
D=8.*(2.286+2.591)
RHO=1465.
C **** SET UP AND CALCULATIONS FOR VOLUME OF REGOLITH REQUIRED
B=(R+T)/SIN(ANOT)+D/TAN(ANOT)
H=(R+T)/COS(ANOT)+D
VOL=(B**2.0*H/3.0-2.0*R**3.0/3.0-R**2*D+D**3./3.0)*PI
C **** OVERALL LOOP TO CHANGE VARIABLE OF INTERSEST
C **** AT THIS JUNCTURE, LET US CHANGE TR AND SEE HOW
C WORK AND SMAX VARY.
C **** WRITE HEADINGS TO FILE ****
WRITE(2,*)'WORK'
WRITE(3,*)'SMAX'
WRITE(4,*)'TR'
WRITE(5,*)'VMAX'
C ****INITIALIZE AND SET UP WHILE DO LOOP
TR=0.005
DOWHILE(TR.LT.1.0)
C **** SET UP AND CALCULATE MAXIMUM S AND STEP SIZE ****
SMAX=SQRT(VOL/TR/PI+B**2.)
C UPPER LIMIT OF INTEGRATION IS SMAX.
C LOWER LIMIT OF INTEGRATION IS B
STEP=(SMAX-B)/REAL(N)
SUM1=0.0
SUM2=0.0
C ****SET UP MAIN LOOP****
S=B
FNOT=DWORK(RHO,S,H,DELT,G,THETA,TR)
FN=DWORK(RHO,SMAX,H,DELT,G,THETA,TR)
S=B+STEP
DO 10 I=1,(N-1),2
SUM1=SUM1+DWORK(RHO,S,H,DELT,G,THETA,TR)
S=S+2.0*STEP
10 CONTINUE
S=B+2.0*STEP
DO 20 I=2,(N-2),2
SUM2=SUM2+DWORK(RHO,S,H,DELT,G,THETA,TR)
S=S+2.0*STEP
20 CONTINUE
INT=STEP/3.*(FNOT+FN+4.*SUM1+2.*SUM2)
WRITE(2,100)INT
WRITE(3,100)SMAX
WRITE(4,100)TR
100 FORMAT(1X,F20.3)
TR=TR+.005
ENDDO

```

```

STOP
END
C *****
C ***** FUNCTION DWORK *****
C *****
FUNCTION DWORK(RHOD,SD,HD,DELTD,GD,THETAD,TR)
C THIS FUNCTION SOLVES THE FUNCTION TO BE INTEGRATED BASED ON A
C VALUE OF SD. FROM THIS FUNCTION THE SUBROUTINE BISECT IS CALLED.
C THE OTHER VARIABLES PASSED ARE FOR THE PURPOSE OF PASSING THEM
C TO THE SUBROUTINE BISECT LATER. THIS FUNCTION IS TO BE USED
C WITH THE PROGRAM INTEGR TO SOLVE FOR THE WORK REQUIRED TO MOVE A
C CERTIAN AMOUNT OF WORK. THE "D" MAKE THE VARIABLES IDENTIFIABLE
C TO THIS FUNCTION
C
C VARIABLE IDENTIFICATION
C RHOD=DENSITY OF REGOLITH, KG/M^3
C SD=DISTANCE FROM THE CENTER OF THE HABITAT, M
C XLD=LOWER GUESS(TO BE USED BY BISECT)
C XUD=UPPER GUESS(TO BE USED BY BISECT)
C ESD=STOPPING CRITERION (%)(TO BE USED BY BISECT)
C EAD=APPROXIMATE ERROR (%)(TO BE USED BY BISECT)
C XRD=ROUTE ESTAMITE (TO BE USED BY BISECT)
C MAXIT=MAXIMUM NUMBER OF ITERATIONS (TO BE USED BY BISECT)
C ITER=NUMBER OF ITERATIONS (TO BE USED BY BISECT)
C VD=LAUNCE VELOCITY, M/S (TO BE USED BY BISECT)
C HD=HEIGHT OF HABITAT ABOVE THE GROUND, M (TO BE USED BY BISECT)
C DELTD=HEIGHT OF DEVICE ABOVE GROUND ZERO, M (TO BE USED BY BISECT)
C GD=GRAVITY, M/S/S (TO BE USED BY BISECT)
C THETAD=ANGLE OF DEPARTURE FOR LAUNCH, RADIANS (TO BE USED BY BISECT)
C TR=DEPTH OF SCOOP, M
C PI=3.14
C
C DECLARE AND TYPE VARIABLES
REAL RHOD,SD,XLD,XUD,ESD,EAD,XRD,VD,HD,DELTD,GD,THETAD,PI,TR
INTEGER MAXITD,ITERD
C
C SET UP CONSTANT VALUES AND VALUES TO BE USED AS INITIAL GUESS
C ETC. BY BISECT
PI=3.141592654
XLD=SQRT(SD*GD/SIN(2.0*THETAD))-1.
XUD=XLD+2.0
DOWHILE(VZERO(XUD,SD,HD,DELTD,GD,THETAD).LT.0.0)
  XUD=XUD+1
ENDDO
MAXITD=200
ESD=.1
C
CALL BISECT(XLD,XUD,ESD,XRD,EAD,MAXITD,ITERD,VD,SD,HD,DELTD,
+GD,THETAD)
DWORK=.5*RHOD*VD**2.*2.0*PI*TR*SD
RETURN
END

```



```

C *****
C ***** SUBROUTINE BISECT *****
C *****
C SUBROUTINE BISECT(XL,XU,ES,XR,EA,MAXIT,ITER,VB,SB,HB,DELTB,
+GB,THETAB)
C THIS PROGRAM SUBROUTINE SOLVES TO FIND THE ROUT OF AN EQUATION
C USING THE BISECTION METHOD. IT IS TO BE USED WITH THE MAIN
C PROGRAM INTEGR1. IT REQUIRES THE EQUATION TO BE SUPPLIED BY AN
C EXTERNAL FUNCTION.
C
C XL=LOWER GUESS
C XU=UPPER GUESS
C XR=ROUT ESTIMATE
C ES=STOPPING CRITERION (%)
C EA=APPROXIMATE ERROR (%)
C MAXIT=MAXIMUM NUMBER OF ITERATIONS
C ITER=NUMBER OF ITERATIONS
C TEST=TEST TO SEE HOW ACCURATE ANSWER IS
C THE FOLLOWING VARIABLES ARE USED TO PASS INFORMATION TO
C THE FUNCTION VZERO,THE "B" IS IDENTIFY THEM AS THE BISECT
C VERSION
C VB=LAUNCH VELOCITY, M/S
C SB=DISTANCE FROM CENTER OF HABITAT, M
C HB=HEIGHT OF HABITAT EXTENDING ABOVE THE GROUND, M
C DELTB=HEIGHT ABOVE GROUND ZERO FROM WHICH THE REGOLITH IS THROWN, M
C GB=GRAVITY, M/S/S
C THETAB=ANGLE OF DEPARTURE, RADIANS
C
C DECLARE AND TYPE VARIALBES
REAL XL,XU,XR,ES,EA,TEST,VB,SB,HB,DELTB,GB,THETAB
INTEGER MAXIT,ITER
C
C INTIALIZE AND BEGIN
ITER=0
EA=1.1*ES
DOWHILE(EA.GT.ES.AND.ITER.LT.MAXIT)
  XR=(XL+XU)/2.
  ITER=ITER+1
  IF(XL+XU.NE.0.0)THEN
    EA=ABS((XU-XL)/(XL+XU))*100.
  ENDIF
  TEST=VZERO(XL,SB,HB,DELTB,GB,THETAB)*
+ VZERO(XR,SB,HB,DELTB,GB,THETAB)
  IF(TEST.EQ.0.0)THEN
    EA=0.
  ELSE
    IF(TEST.LT.0.)THEN
      XU=XR
    ELSE
      XL=XR
    ENDIF
  ENDIF
ENDIF

```

```

ENDDO
VB=XR
RETURN
END
C *****
C ***** FUNCTION VZERO *****
C *****
FUNCTION VZERO(VV,SV,HV,DELTV,GV,THETA V)
C THIS FUNCTION SOLVES A FORM OF EQUATION 55.1 FROM MY NOTEBOOK
C IT IS TO BE USED WITH THE SUBROUTINE BISECT. THIS FUNCTION
C ACCEPTS A VALUE OF VV, SV, HV,GV,THETA V AND DELTV TO BE
C INDEPENDANT VARIABLES. THE CHARACTER V IS TO DIFFERENTIATE
C THESE VALUES FROM THOSE IN THE MAIN PROGRAM.
C VARIABLE IDENTIFICATION
C VV=VELOCITY OF THE REGOLITH AS IT LEAVES THE DEVICE
C SV=DISTANCE FROM THE CENTER OF THE HABITAT, M
C HV=HEIGHT OF THE HABITAT PROTRUDING FROM THE GROUND, M
C DELTV=HEIGHT FROM WHICH THE DEVICE IS THROWING, M
C GV=GRAVITY ON THE MOON, M/S/S
C THETA V=ANGLE OF DEPARTURE FOR THE THROW
C UNDER=WORKING VARIBALE USED TO CHECK FOR SQR T(-NUMBER)
C
C VARIABLE TYPE DECARATION
REAL VV,SV,HV,DELTV,GV,THETA V,UNDER
C AVOID PROBLEMS OF HAVING SQR T(-N)
UNDER=(VV*SIN(THETA V))**2/2.0/GV+DELTV
IF(UNDER.LT.HV)THEN
    UNDER=HV
ELSE
    UNDER=UNDER
ENDIF
C CALCULATE FUNCTION
VZERO=SV+VV*COS(THETA V)*(VV*SIN(THETA V)/GV
D+(2.0/GV*(UNDER-HV))**.5)
RETURN
END

```

Assumptions:

- 1.) As discussed above, a model was chosen from previous work to provide the method of regolith transportation
- 2.) The work required to turn the device around is negligible compared to the work required to transport the unit.
- 3.) The regolith gathered on each trip is a square of size A_L by A_L with a depth z_r .

Nomenclature:

- A_L = side of square area scooped up
 B = radius of cone of regolith covering habitat.
 S_{max} = outer radius of area cleared
 N_{rings} = Number of rings required to clear the area
 N_{trips} = Number of trips required to completely scoop the regolith from one ring.
 X = distance traveled to clear one ring
 R = radius of ring currently being cleared
 X = total distance traveled by device
 R_{CE} = rolling resistance of device when empty
 R_{CF} = rolling resistance of device when full.
 M = mass of device
 D = wheel diameter
 n = soil deformation factor
 k_c = coefficient of cohesive deformation modulus
 k_ϕ = coefficient of frictional deformation modulus
 b = wheel width

Methodology:

The work required is the force required to roll multiplied by the distance rolled added to the energy required to lift the regolith onto the habitat. The work required to the regolith will be analyzed later.

Analysis:

Distance Traveled

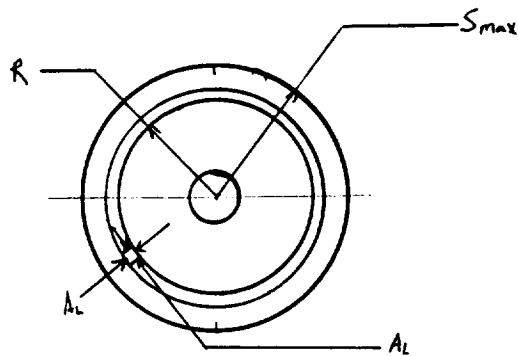

For each ring, need to make a number of trips to clear all the regolith.

$$2\pi R = N_{trips} A_L \quad \text{or}$$

$$N_{trips} = \frac{2\pi R}{A_L} \quad (D10)$$

$$N_{rings} = \left(\frac{S_{max} - B}{A_L} \right) \quad (D11)$$

The total distance traveled to scoop out one ring is

$$X = (R+B)2 N_{trips} \quad (D12)$$

$$R = N_{rings} \cdot A_L \quad (D13)$$

Substitute (D10) and (D13) into (D12) yields

$$X = 4 \pi N_{rings} (N_{rings} A_L + B) \quad (D14)$$

Rearranging (D14) and summing for each ring yields

$$X = \sum_{N=0,1,2,\dots}^{N = \frac{S_{max}-B}{A_L}} 4 \pi N (B + N A_L) \quad (D15)$$

Rolling Resistance

From [D1]

$$R_c = \frac{\left(\frac{3 M g}{\sqrt{D}} \right)^{\frac{2n+2}{2n+1}}}{3(n-1) \left(\frac{2n+2}{2n+1} \right) (n+1) (K_c + b k_f)^{\left(\frac{1}{2n+1} \right)}} \quad (D16)$$

Work

Because the device spends half of the time empty

$$W = \frac{R_{CF} X}{2} + \frac{R_{CF} X}{2}$$

Also, if the work required to fill the cone is W_c ,

$$W = \frac{R_{CE}X}{2} + \frac{R_{CF}X}{2} + W_c \quad (D17)$$

Because of the tedious procedure for calculating X , a computer program was used to solve equations (D15) and (D17). This computer program is listed on the following pages. Output from this program was combined with output from Integr1 to generate the graphs shown in Figure D4 and Figure D5.

PROGRAM ROLLWRK

```
C THIS PROGRAM INTEGRATES THE WORK REQUIRED TO COVER THE HABITAT
C WITH REGOLITH. THE MAIN PROGRAM WILL CALCULATE THE VOLUME AND
C OTHER INFORMATION BASED ON CRITICAL INPUT VALUES. AT THIS POINT
C CRITICAL INPUT VALUES WILL BE ENTERED MANUALLY IN THE SOURCE CODE.
C AT A LATER DATE, THE PROGRAM MAY BE MODIFIED TO ACCEPT A USER
C CREATED INPUT FILE.
C ****USER SPECIFIED VALUES
C G=GRAVITY ON THE MOON
C TR=THICKNESS OF REGOLITH SCOOPED, M
C R=RADIUS OF HABITAT, M
C T=THICKNESS OF REGOLITH ON TOP OF HABITAT, M
C ANOT=ANGLE OF REPOSE FOR REGOLITH, RAD
C RHO=DENSITY OF REGOLITH, KG/M/M/M
C PI=3.141592654
C D=DISTANCE FROM CENTER OF HABITAT TO GROUND ZERO, M
C **** CALCULATED AND USED VARIABLES ****
C VOL=VOLUME OF REGOLITH REQUIRED TO COVER HABITAT, M^3
C I=STEP COUNTER
C **** ENTER USER VALUES ****
C **** DELCARE AND TYPE VARIABLES
REAL G,TR,R,T,ANOT,RHO,PI,D,AL,SMAX,WORK,VOL,VOLMDU,RCEMPT
REAL RCFULL,MASSE,MASSF,WORKLFT,THETA,B,H,WHEELD,NRC,BRC,KC,KPHI
INTEGER I,N
C ***** OPEN AND SET UP PRINT FILES *****
OPEN(UNIT=2,FILE='WORKR.OUT')
OPEN(UNIT=3,FILE='SMAXR.OUT')
OPEN(UNIT=4,FILE='TRR.OUT')
OPEN(UNIT=5,FILE='XBAR.OUT')
OPEN(UNIT=6,FILE='AL.OUT')
OPEN(UNIT=7,FILE='N.OUT')
PI=3.141592654
G=1.624
ANOT=37.*PI/180.
T=.5
R=8.
TR=.1
THETA=45.*PI/180.
D=8.*(2.286+2.591)
WHEELD=1.6
RHO=1465.
VOLMDU=1.8*1.55*1.1
MASSE=1500.
MASSF=MASSE+VOLMDU*RHO
WORKLFT=103000000.
NRC=1.0
KC=1400.
KPHI=820000.
BRC=.3
C **** SET UP AND CALCULATIONS FOR VOLUME OF REGOLITH REQUIRED
B=(R+T)/SIN(ANOT)+D/TAN(ANOT)
H=(R+T)/COS(ANOT)+D
```

```

VOL=(B**2.0*H/3.0-2.0*R**3.0/3.0-R**2*D+D**3./3.0)*PI
C **** SET UP CALCULATIONS FOR ROLLING RESISTANCE
RCEMPT=((3.*MASSE*G/SQRT(WHEELD))**((2.*NRC+2.)/(2.*NRC+1.)))
D/((3.-NRC)**((2.*NRC+2.)/(2.*NRC+1.))*(NRC+1.)*((KC+BRC*KPHI)**(1.
D/(2.*NRC+1.))))
RCFULL=((3.*MASSF*G/SQRT(WHEELD))**((2.*NRC+2.)/(2.*NRC+1.)))
D/((3.-NRC)**((2.*NRC+2.)/(2.*NRC+1.))*(NRC+1.)*((KC+BRC*KPHI)**(1.
D/(2.*NRC+1.))))
WRITE(*,*)RCFULL
WRITE(*,*)RCEMPT
C **** OVERALL LOOP TO CHANGE VARIABLE OF INTERSEST
C **** AT THIS JUNCTURE, LET US CHANGE TR AND SEE HOW
C WORK AND SMAX VARY WITH TR.
C **** WRITE HEADINGS TO FILE ****
WRITE(2,*)'WORK,R'
WRITE(3,*)'SMAX'
WRITE(4,*)'TR'
WRITE(5,*)'XBAR'
WRITE(6,*)'AL'
WRITE(7,*)'N'
C ****INITIALIZE AND SET UP WHILE DO LOOP
TR=0.005
DOWHILE(TR.LT.1.0)
  SMAX=SQRT(VOL/TR/PI+B**2.0)
  AL=SQRT(VOLMDU/TR)
  N=INT((SMAX-B)/AL)+1
  XBAR=0.0
  DO 10, I=0,N,1
    XBAR=XBAR+4.0*PI*REAL(N)*(B+REAL(N)*AL)
10  CONTINUE
  WORK=RCEMPT*XBAR/2.0+RCFULL*XBAR/2.0+WORKLFT
  WRITE(5,*)XBAR
  WRITE(2,*)WORK
  WRITE(4,*)TR
  WRITE(3,*)SMAX
  WRITE(6,*)AL
  WRITE(7,*)N
  TR=TR+.005
ENDDO
STOP
END

```

Part of the work required with a standard rolling method is the work required to lift the regolith on top of the habitat. A method using a conveyor belt is shown in Figure D1. A method using a front loader is shown in Figure D2. The work derivations for each method follow their respective picture.

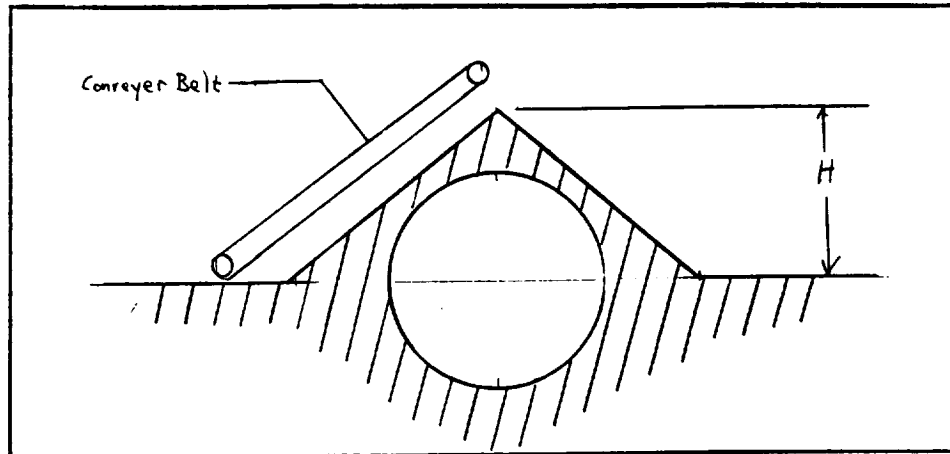

Figure D1.

Use of a conveyer belt to move regolith

$$W = F \cdot d = \rho V g H \quad (D18)$$

with

$$\rho = 1465 \text{ kg/m}^3$$

$$V = 3142 \text{ m}^3$$

$$g = 1.624 \text{ m/s}^2$$

$$H = 13.8 \text{ m}$$

$$W = 103 \text{ MJ}$$

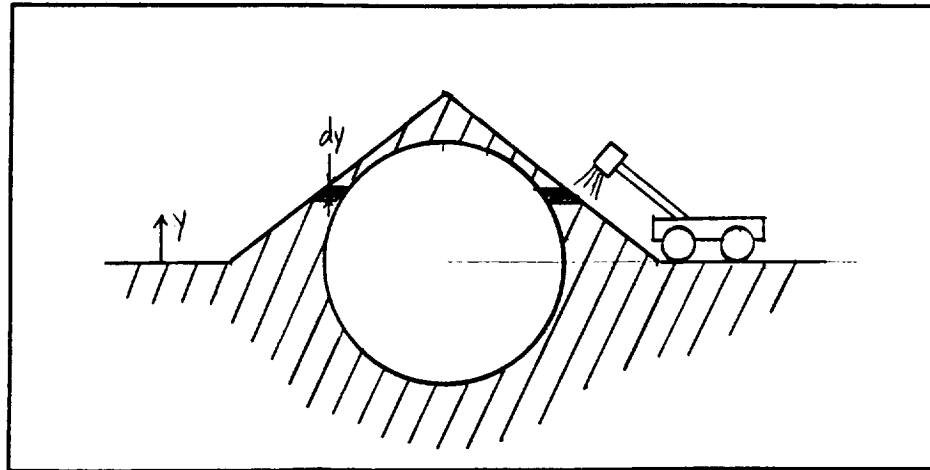

Figure D2. Method for positioning regolith on the habitat using a front loader

Methodology:

The procedure is to integrate the work required for each area $A \times dy$. The procedure is similar to the volume calculation in Appendix G. So the same nomenclature will be used.

Analysis:

$$W = \int y \rho g V(y) dy \quad (D19)$$

substitute for $V(y)$ from Appendix G

$$W = \int_0^{R+D} \pi \rho g y \left[\left(-\frac{y}{H}(y-H) \right)^2 - \left(\sqrt{R^2 - (y-D)^2} \right)^2 \right] dy + \int_{R+D}^H \pi \rho g y \left(-\frac{y}{H}(y-H) \right)^2 dy \quad (D20)$$

Integrating the definite integral in (D20) yields

$$W = \pi \rho g \left\{ \begin{aligned} & -\frac{(R+D)^2 R^2}{2} + \frac{(R+D)^4}{4} - \frac{2(R+D)^3 D}{3} \\ & + \frac{(R+D)^2 D^2}{2} + \frac{B^2}{A^2} \left(\frac{A^4}{12} \right) \end{aligned} \right\} \quad (D21)$$

where the variables are as defined in Appendix G.

Conclusion:

With values of

$$\rho = 1465 \text{ kg/m}^3$$

$$g = 1.624 \text{ m/s}^2$$

$$R = 8 \text{ m}$$

$$D = 3.123 \text{ m}$$

$$B = 18.3 \text{ m}$$

$$A = 13.8 \text{ m}$$

yields

$$W = 80.7 \text{ MJ.}$$

When performing the rolling work, either this solution or the solution to equation D18^o needs to be added to the total rolling work.

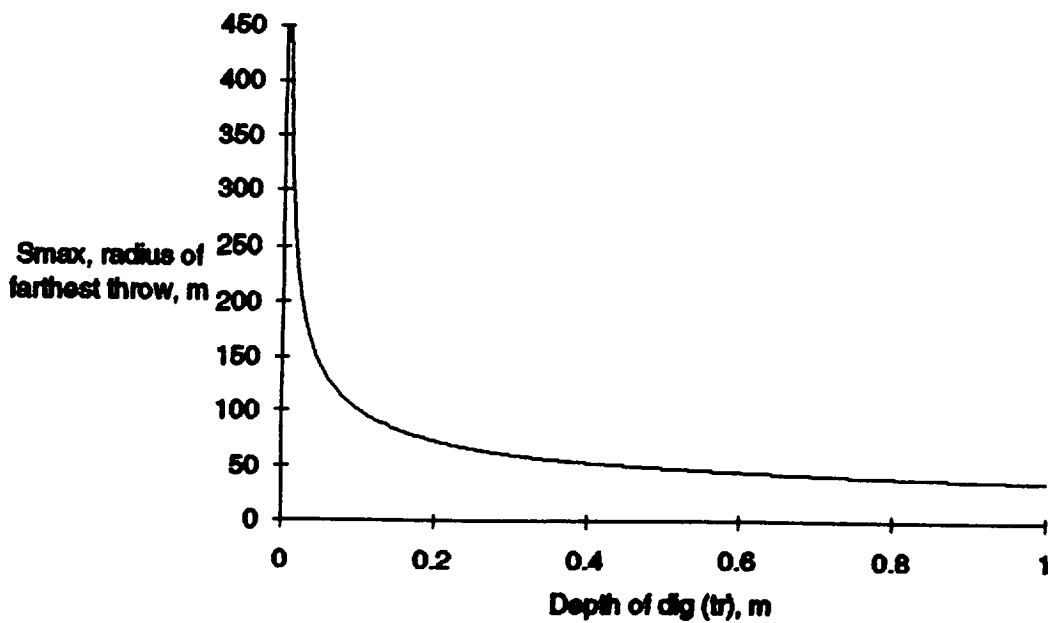

Figure D3. Radius of area that must be cleared as a function of Depth of dig.

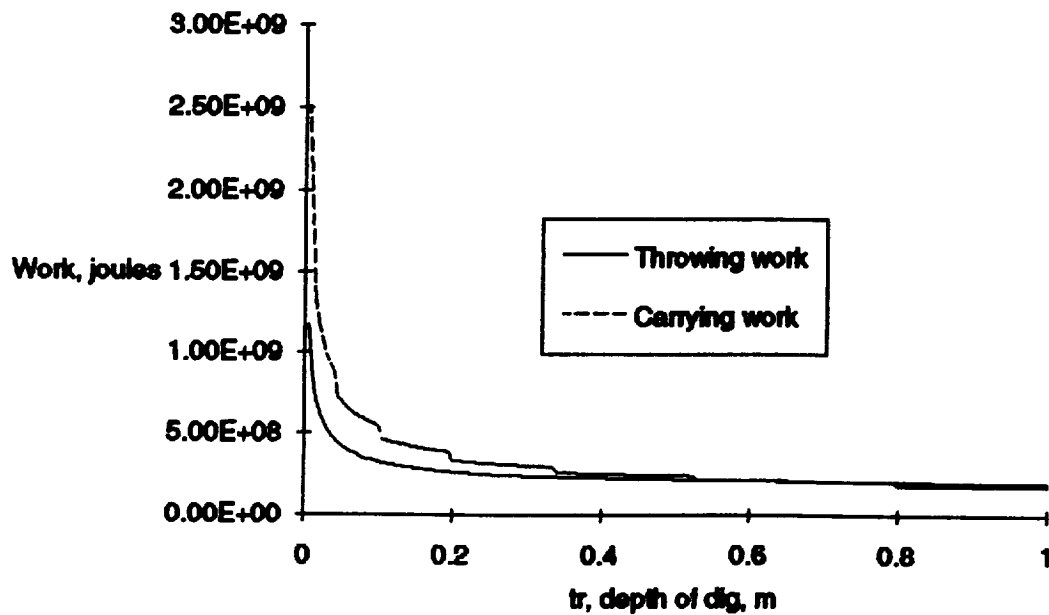

Figure D4. Work to move the regolith vs. depth of dig

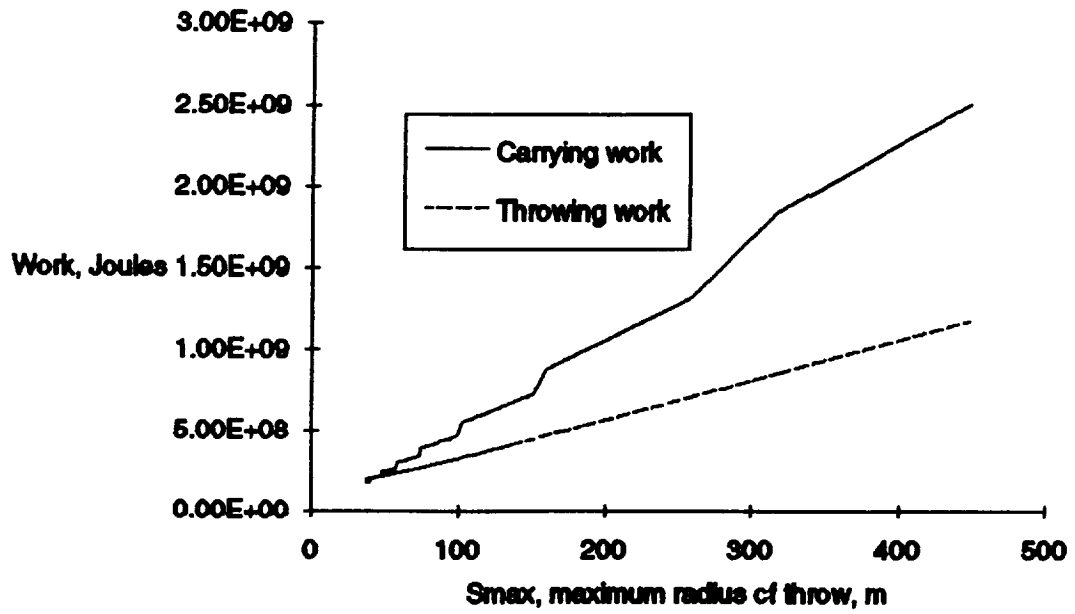
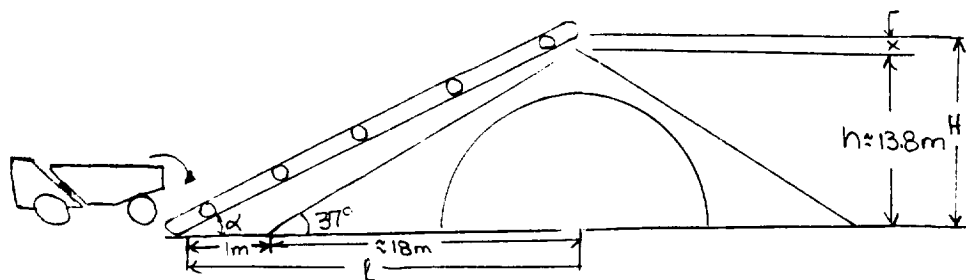

Figure D5 Work to move regolith as a function of surface area cleared

FEASIBILITY OF CONVEYOR BELT



• LENGTH OF CONVEYOR BELT NEEDED

Assuming: regolith has an angle of repose of 37°

$$H = h + x \approx 14\text{m} \quad \left. \begin{array}{l} \\ \\ \end{array} \right\} \alpha = \tan^{-1} \frac{14}{19} = 36.4^\circ \approx 36^\circ$$

$$l = 19\text{m}$$

$$L = \text{length of conveyor belt} = (19^2 + 14^2)^{1/2} = 23.6\text{m}$$

• POWER TO DRIVE CONVEYOR BELT

The total power required to drive the conveyor belt is equal to the sum of the power required to

- 1- move empty belt
- 2- move load horizontally
- 3- lift load at incline α

① Power to move empty belt

Assume: belt velocity = 0.15m/s

Distance between centers = $23.6\text{m} =$

Power required for this length of belt at different belt widths vary between $0.2 - 1\text{kW}$

For an average width ($\approx 30\text{in}$) $\bar{P} \approx 0.5\text{kW}$ [02]

② Power to move load horizontally

Power to move 100Tons/h horizontally is given by

$$hp = 0.4 + 0.00325L \quad \text{where } L = \text{distance between centers (ft)}$$

[03]

For other capacities the hp is proportional

...cont

$$L = 23.6\text{m} = 77.4\text{ft}$$

To obtain the capacity that we are moving, assume

$$V = \text{Total Volume of regolith to cover habitat} = 3140\text{m}^3$$

$$t = \text{time to complete task} = 14 \text{ earth days} = 336 \text{ hours}$$

$$\rho_{\text{regolith}} = 1465 \text{ kg/m}^3$$

$$\text{Capacity} = T = \frac{V \times \rho}{t} = \frac{(3140\text{m}^3)(1465 \text{ kg/m}^3)}{336\text{h}} = 13690.7 \frac{\text{kg}}{\text{h}}$$

$$T = 15.09 \text{ Ton/h}$$

$$hp = 0.4 + 0.00325(77.4\text{ft}) = .6516\text{hp} @ 100 \text{ Ton/h}$$

$$hp \text{ at } 15 \text{ Ton/h} = .098\text{hp} = 73.3\text{W}$$

③ Power to lift load at $\alpha = 36^\circ$

$$P_R = (0.002H + 0.001V) CT \quad [0\%]$$

where $H = \text{horizontal run (ft)} = 62.3\text{ft}$

$V = \text{Vertical lift (ft)} = 45.9\text{ft}$

$C = \text{constant} = 1.2$ for flour (composition assumed closer to dirt)

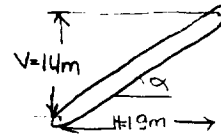

$$P_R = [0.002(62.3\text{ft}) + 0.001(45.9\text{ft})] 1.2 * 15.09 \text{ Ton/h}$$

$$P_R = 3.1 \text{ hp} = 2.3 \text{ kW}$$

So TOTAL POWER REQUIRED TO DRIVE CONVEYOR BELT =

$$P_T = 0.5 \text{ kW} + 0.073 \text{ kW} + 2.3 \text{ kW}$$

$$= 2.873 \text{ kW}$$

$$P_T \approx 2.9 \text{ kW} = 3.85 \text{ hp}$$

• WEIGHT OF CONVEYOR BELT

Length = 23.6m

Transfer rate = 15 Ton/h

The weight of the conveyor belt was estimated by obtaining the weight of belts & structures of earth machinery.

1- Conveyor Belt Structure →

a stainless steel conveyor with this dimensions will weigh around 2000 to 2500 lbs (Ballpark figure) [D7]

Komplex, conveyor structure manufacturer

Assuming same amount of material needed for lunar conveyor, and using Titanium alloy instead of stainless steel to provide a more abrasion resistant material.

$$\frac{W_{ss}}{\rho_{ss}} = \frac{W_{Ti}}{\rho_{Ti}} \quad \text{where } W_i = \text{weight of structure for material } i$$

ρ_i = density of material i

$$\rho_{ss} = 7.79/\text{cm}^3$$

$$\rho_{Ti} = 4.429/\text{cm}^3$$

$$W_{Ti} = \frac{(2500 \text{ lbs})(7.79/\text{cm}^3)}{4.429/\text{cm}^3} = 1435 \text{ lbs} \approx 650 \text{ kg}$$

2- CONVEYOR BELT

for 1m wide belt weights vary between 0.39 lb/ft² to 1 lb/ft² [D6].

since regolith is very abrasive & has high density, a strong material is needed for the belt so W of belt assumed to be 1 lb/ft²

$$W_{\text{belt}} = (1 \text{ lb/ft}^2)(77.43 \text{ f})(3.28 \text{ f}) = 254 \text{ lbs} \Rightarrow 115 \text{ kg}$$

$$W = 1 \text{ m} = 3.28 \text{ f}$$

$$L = 23.6 \text{ m} = 77.43 \text{ f}$$

3- Total weight of conveyor belt assembly =

$$W_T = (1435 + 254) \text{ lbs} = 1689 \text{ lbs} \approx \boxed{766 \text{ kg}} = W_T$$

* not including drive motor

FEASIBILITY OF FRONT LOADER

The major problems encountered with a front loader are the size of the arm necessary to reach the top of the habitat and the moment this arm creates at the connection to the rest of the device. If this moment is not counteracted the device will flip.

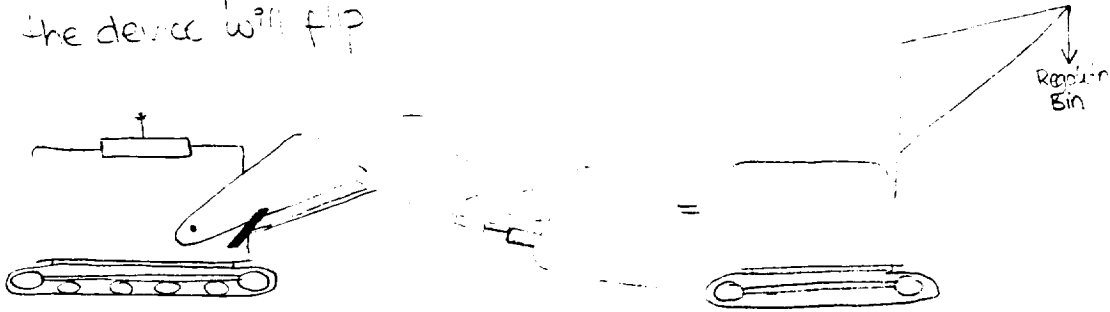

FOR FIRST ORDER APPROXIMATION ASSUME THAT THE LOADER ARM CONSISTS OF A 3 MEMBER TRUSS.

- REQUITH BIN ACTS AS POINT LOAD
- BASE SUPPORTING THE BIN ARE RIGID

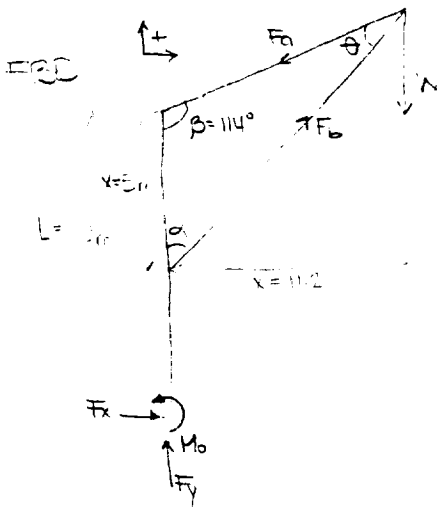

$W = \text{Weight of requith}$

$$W = \rho g V$$

$$\rho = 1404 \text{ kg/m}^3$$

$$g = 1.624 \text{ m/sec}^2$$

Assume $V = 0.5 \text{ m}^3$ (equivalent to 60 $20 \times 20 \times 20 \text{ cm}^3$ throws)

$$\text{so } W = (1.624 \text{ m/sec}^2)(1404 \text{ kg/m}^3)(0.5 \text{ m}^3)$$

$$W = 1.14 \text{ kN}$$

$$\sum F_x = 0 \quad -F_a \sin \beta + F_b \sin \alpha = 0$$

$$F_a = \frac{F_b \sin \alpha}{\sin \beta}$$

$$\sum F_y = 0 \quad F_a \cos \beta + F_b \cos \alpha - W = 0 \quad \therefore F_a = \frac{W - F_b \cos \alpha}{\cos \beta}$$

$$\sum M_o = 0 \quad (F_a \sin \beta)L - (F_b \sin \alpha)(L-x)$$

Assume $\beta = 114^\circ$
 $x = 5\text{m}$

which gives

$$\bar{F}_a = 2.47\text{N}$$

$$\bar{F}_b = 3.2\text{N}$$

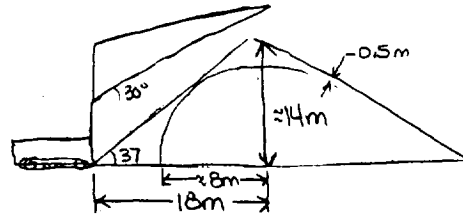

The total length of the loader's throwing arm needs to be

$$L_{\text{arm}} = \frac{18\text{m}}{\cos 30} = 21\text{m}$$

The moment created by this arm is approx. $20.5\text{ kN}\cdot\text{m}$
 which is really big & will require a heavy device to counteract it

⇒ In order to counteract the moment exerted by the throwing arm the loader needs to be really large & massive, also the length of the arm makes the front loader not feasible for covering lunar habitats

As means of Comparison; a standard front end loader designed for mining purposes on the Moon has the following characteristics: Bucket size = 0.5m^3

Vehicle mass = 2600 kg

Vehicle power = 22 kW

Vehicle Volume = 21m^3 [47]

This vehicle is much smaller than the one necessary to reach the top of a 16m diameter habitat.

FEASIBILITY OF BUCKET ASSEMBLY

The weight of the bucket configuration was obtained by comparison to a coal bucket carrier.

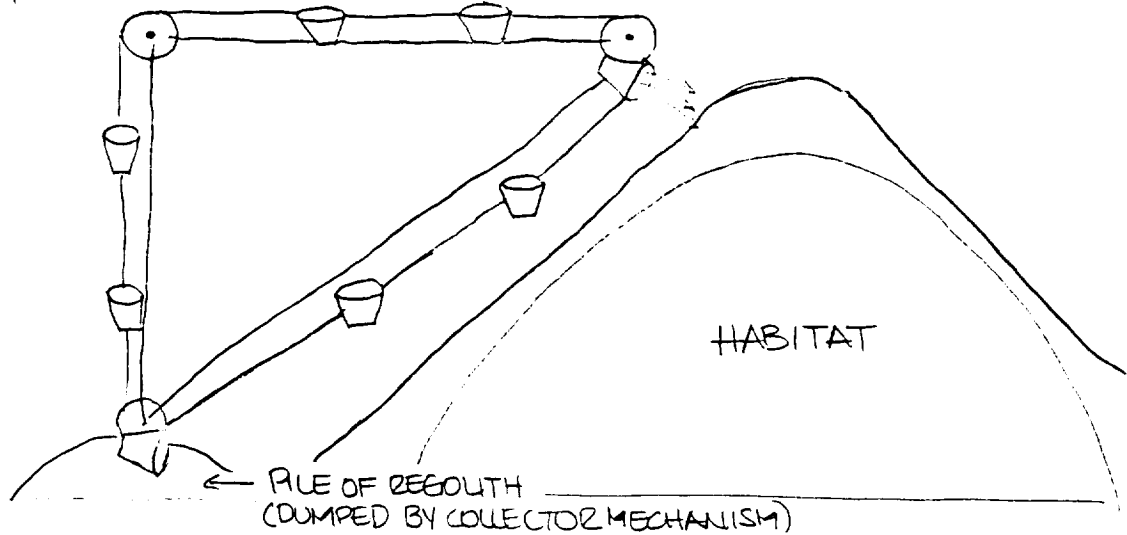

This bucket method was used to estimate the mass of the system since it reduces the need of coordination between gathering & lifting mechanisms

Bucket size assumed to be $\rightarrow L = 12 \text{ in}$

$W = 12 \text{ in}$

$D = 6 \text{ in}$

spacing between buckets = 18 in

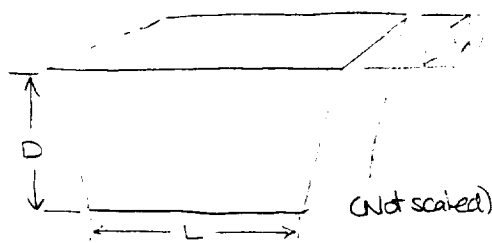

Total length of cable needed =

$$L_T = (18.3 + 14 + 23.6) \text{ m} = 55.3 \text{ m}$$

$$= 2177 \text{ in}$$

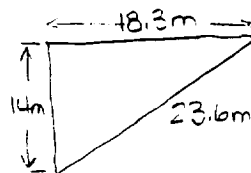

so # of buckets needed = $\frac{2177 \text{ in}}{18 \text{ in}} = 121 \text{ buckets}$

This size of bucket configuration will carry 29 Tons/h of coal at 100 ft/min. The weight of the carrier per feet of cable is 36 lbs. [18]

To modify this for a regolith carrier, with a capacity of $C = 15.09 \text{ Ton/h}$ direct proportionality was used

$$\frac{W_{\text{COAL CARRIER}}}{C_{\text{COAL}} \rho_{\text{COAL}}} = \frac{W_{\text{REGOLITH CARRIER}}}{C_{\text{REGOLITH}} \rho_{\text{REGOLITH}}}$$

$$\rho_{\text{COAL}} = 481 \text{ kg/m}^3$$

$$\rho_{\text{REGOLITH}} = 1465 \text{ kg/m}^3$$

$$W_{\text{REGOLITH CARRIER}} = \frac{(36 \text{ lbs})(15 \text{ Ton/h})(1465 \text{ kg/m}^3)}{(29 \text{ Ton/h})(481 \text{ kg/m}^3)} = 56.7 \text{ lbs} = 25 \text{ kg}$$

As seen here, the weight of a bucket assembly is very small. This value however does not include the weight of the poles or structure to keep this mechanism on place or the weight of the motor to drive the buckets

REFERENCES

- D1. Bekker, M.G., Off Road Locomotion, (The University of Michigan Press: Ann Arbor, MI, 1960), p. 28.
- D2. Avallone, E.A. Baumeister III, Mark's Standard Handbook for Mechanical Engineers: 9th Edition, (McGraw-Hill, New York 1987), p. 10-55.
- D3. Avallone, E.A. Baumeister III, Mark's Standard Handbook for Mechanical Engineers: 9th Edition, (McGraw-Hill, New York 1987), p. 10-55.
- D4. Avallone, E.A. Baumeister III, Mark's Standard Handbook for Mechanical Engineers: 9th Edition, (McGraw-Hill, New York:1987), p. 10-55.
- D5. Gongaware, Joe, Kamflex, conveyor structure manufacturer, phone interview.
- D6. Willis, Dale, Great Lakes Belting, conveyor belt manufacturer, phone interview.
- D7. Exploration Studies Technical Report, Vol. III: Planetary Surface Systems, (The Office of Exploration, JSC, Houston, TX:1989), p. 5-92.

D8. Avallone, E.A. Baumeister III, Mark's Standard Handbook for Mechanical Engineers: 9th Edition, (McGraw-Hill, New York:1987), p. 10-51.

APPENDIX E

Comparison of Rotational and Linear Throwing

This appendix presents a comparison of rotational throwing versus linear throwing. Several factors such as effect on release angle, accuracy and precision of the throwing method, and ease of recocking and reloading were addressed. This quantitative analysis indicated a linear throwing motion was superior.

Another factor to consider is that different throwing motions will have different effects on the dispersion of a thrown load of regolith. This problem is also addressed in this appendix. A rotational arm imparts a velocity gradient across a load of regolith. The outer edge of regolith will move faster than the inner edge, and therefore will travel farther. This difference in velocities disperses the regolith upon release. This dispersion is not seen with a linear throwing motion. There may be dispersion of a load of regolith due to friction between the regolith load and the load chamber walls. This frictional dispersion will be present in both linear and rotational throwing motions. The degree of this dispersion is unknown, and more work needs to be done to determine its severity. In this analysis this effect was assumed negligible.

COMPARISON OF ROTATIONAL AND LINEAR THROWING MOTIONS

ROTATIONAL

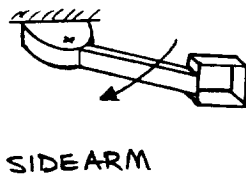

LINEAR

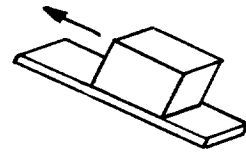

RELEASE ANGLE CONSIDERATIONS

IF USE SIDEARM MECH. THEN THE ENTIRE MECH. MUST BE TILTED TO ALTER RELEASE ANGLE. OVER-HAND MECH. - CAN JUST CHANGE STOPPING POINT OF ARM. MAY THEN HAVE PROBLEM ACHIEVING NEEDED LAUNCH VELOCITY.

MUST TILT MECHANISM TO ALTER RELEASE ANGLE OF DEVICE.

ROTATIONAL

LINEAR

AZIMUTHAL ANGLE CONSIDERATIONS

CAN PIVOT ENTIRE THROWING PLATFORM. CAN ALSO TURN ENTIRE LUNAR ROBOT. WITH SIDEARM MECH., CAN JUST ALTER RELEASE POINT.

HAVE TO PIVOT THROWING PLATFORM OR TURN THE ENTIRE LUNAR ROBOT.

RECOCKING AND RELOADING THROWING MECHANISM CONSIDERATIONS

IF OVERHAND ARM PIVOTS PAST VERTICAL (90°), MUST BE PHYSICALLY MOVED BACK INTO START POSITION. POSSIBLE TO HAVE ARM REBOUND BACK SIDE-ARM \rightarrow SAME PROBLEMS. BUT, IF TILTED SIDEARM TO VARY RELEASE ANGLE, ARM WILL TEND TO FALL BACK INTO START POSITION. EASE OF RELOADING DEPENDS ON LOAD CHAMBER AND DIRT ACQUISITION METHODS.

THROWING DEVICE TILTED TO ALTER RELEASE ANGLE. LOAD CHAMBER TENDS TO SLIDE BACKWARDS TO START POSITION. EASE OF RELOADING DEPENDS ON LOAD CHAMBER, AND DIRT ACQUISITION METHOD.

ROTATIONAL

LINEAR

DISPERSION CONSIDERATIONS

LINEAR VELOCITY PROFILE ACROSS LOAD CHAMBER. PARTICLE ON OUTER EDGE TRAVELS FARTHER THAN PARTICLE ON INNER EDGE. MAY BE FRINGE DISPERSION ON EDGES; STATIC BOUNDARY LAYER B/N LOAD CHAMBER WALL AND REGOLITH LOAD.

CONSTANT VELOCITY PROFILE ACROSS LOAD CHAMBER FACE. NO DISPERSION FROM A VELOCITY DIFFERENCE, AS IN ROTATIONAL. AGAIN, HOWEVER, MAY HAVE FRINGE DISPERSION DUE TO EDGES. THE DEGREE/SEVERITY OF THIS IS UNKNOWN.

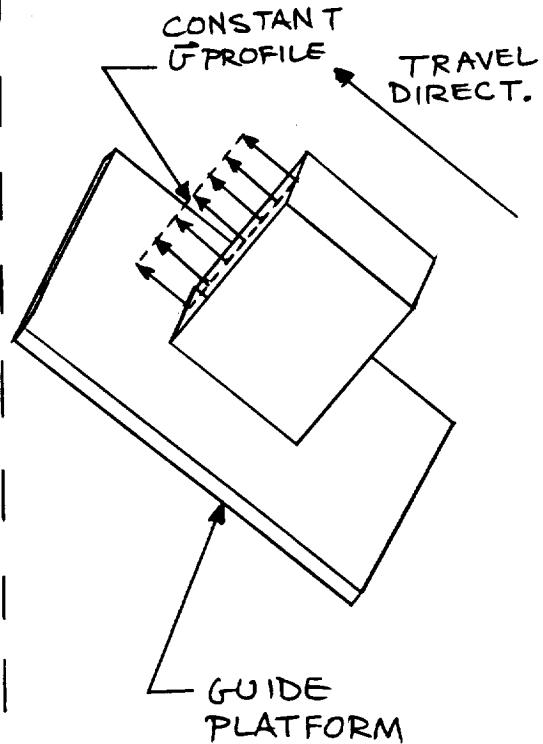
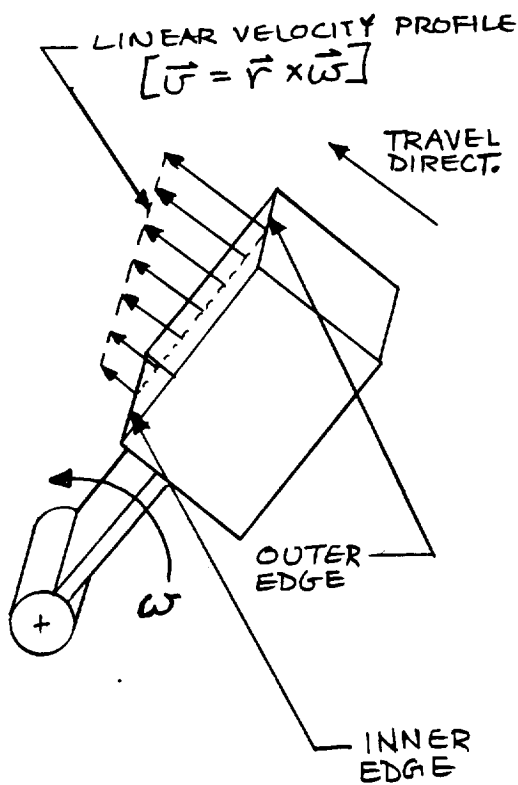

ROTATIONAL

LINEAR

ACCURACY/PRECISION CONSIDERATIONS

- ANGULAR MOMENTUM
(FROM ROTATIONAL
ARM) MAY ALTER
RELEASE ANGLE
SETTING.

- LEAST AMOUNT OF
REGOLITH DISPERSION.
- EASIER TO PRECISELY
CHANGE RELEASE ANGLE.

DISPERSION OF THROWN REGOLITH DUE TO ROTATIONAL THROWING

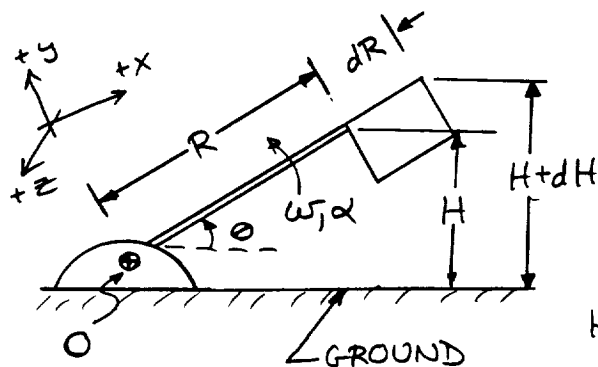

$R \sim$ ARM LENGTH
 $dR \sim$ BUCKET LENGTH
 $\omega \sim$ ANGULAR SPEED
 $\alpha \sim$ ANGULAR ACCEL.
 $\theta \sim$ LAUNCH ANGLE
 $H, H+dH \sim$ HEIGHTS OF
 PARTICLES FROM GROUND
 AT LAUNCH.

PIVOT 'O' AT $(x, y) = (0, 0)$

- PARTICLE AT $x=R$ HAS LOWER LINEAR VELOCITY THAN PARTICLE AT $x=R+dR$
- ASSUME: DISPERSION IN z NEGLECTIBLE
 (i.e. NO DISPERSION DUE TO FRICTION BETWEEN BUCKET WALLS AND REGOLITH.)
- ASSUME: $H \approx H+dH$. IF REGOLITH IS THROWN LARGE DISTANCE, THEN IT (PRACTICALLY) RETURNS TO INITIAL LAUNCH LEVEL.
- ASSUME: TRAJECTORY DESCRIBED BY PARABOLIC MOTION. GOOD ASSUMPTION SINCE THROWING IN NEAR VACUUM.

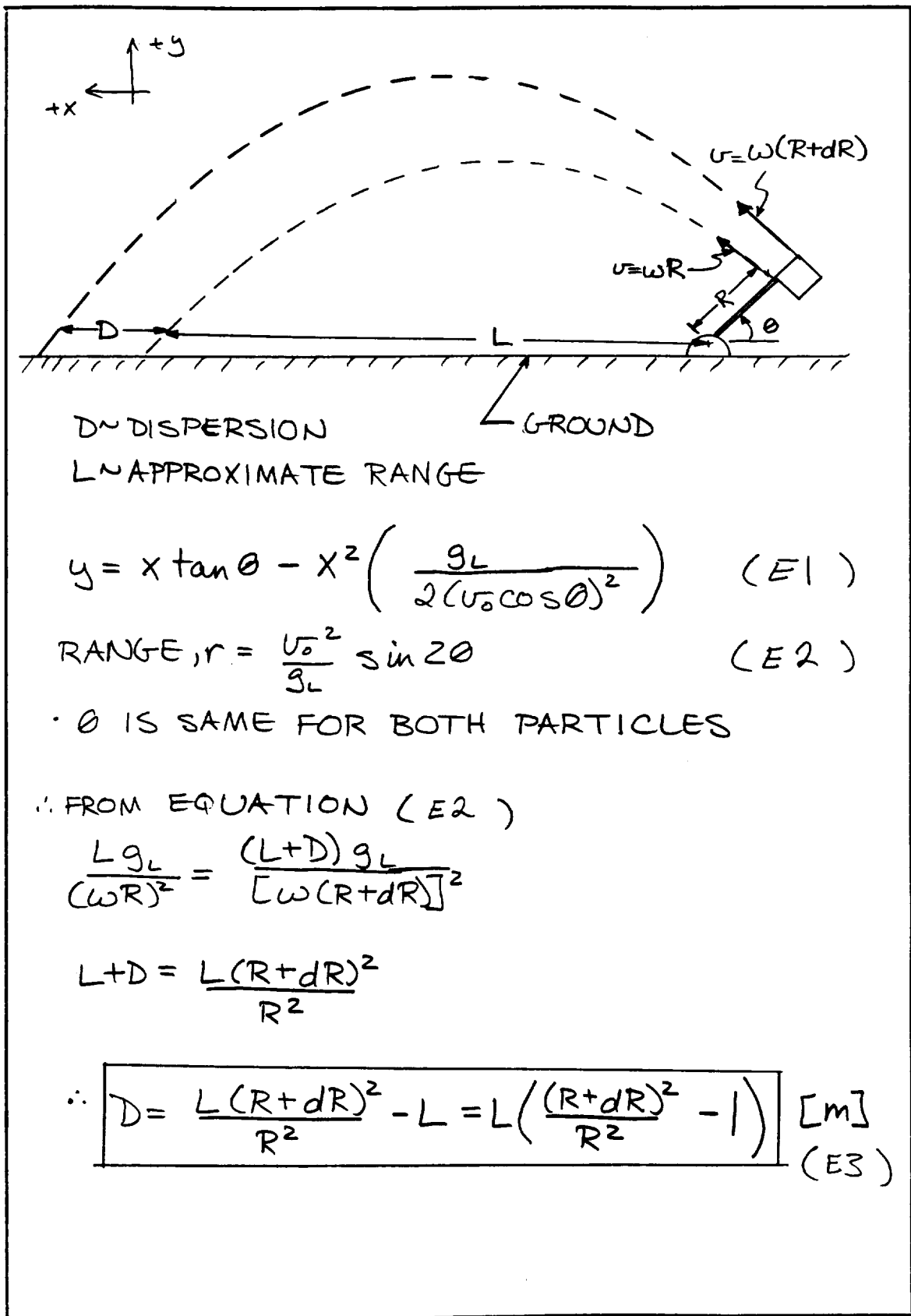

FROM EQUATION (E3)

$$D = \left(\frac{L(R^2 + 2RdR + (dR)^2)}{R^2} \right) - L$$

$$= L \left(1 + \frac{2dR}{R} + \frac{(dR)^2}{R^2} \right) - L$$

$$= L \left(\frac{2dR}{R} + \frac{(dR)^2}{R^2} \right)$$

BUT $L = \frac{\omega^2 R^2}{g_L} \sin 2\theta$

BY EQUATION (E3)

$$\therefore D = \frac{\omega^2 R^2}{g_L} \sin 2\theta \left[\frac{2(dR)}{R} + \frac{(dR)^2}{R^2} \right] \quad [m] \quad (E4)$$

TYPICAL VALUES:

$$U_0 = \omega R = 12 \text{ m/s}$$

$$g_L = \frac{1}{6} g$$

$$\theta = 45^\circ$$

$$R = 0.5 \text{ m}$$

$$dR = 0.2 \text{ m}$$

$$\therefore \underline{\underline{D = 84.579 \text{ m} \quad !!!}}$$

APPENDIX F

Comparison of Energizing Methods

The following appendix presents the analysis used to determine the energizing method that was chosen for the throwing motion. Although a linear throwing motion was chosen for reasons other than the type of torque and angular acceleration required, an analysis of a direct angular connection to a throwing arm is presented. This analysis is shown to illustrate another complication of using a rotational throwing arm. After the rotational throwing arm an arrangement using an electric motor to compress a spring is analyzed. Also, a method using a flywheel for energy storage is analyzed. Lastly, a magnetic energizing approach is investigated. This approach proved unfeasible because it required a length of over 100 meters to accelerate the regolith to the necessary velocity using reasonable magnetic fields. The motor and spring arrangement was chosen as it proved superior in a comparison of geometry, power and torque requirements, and mass.

The main advantage of the spring and motor arrangement is the controllability of the torque required. The required torque is a function of the number of the rotations made by the motor. As long as the necessary power is supplied by the motor, a gear ratio can be used to allow a motor with a wide range of torques to be used.

The feasibility of a linear spring for accelerating a load of regolith is also demonstrated in this appendix by two methods. The first is a work-energy method. The second is a dynamic model of a spring-mass system. The two methods provided results that are approximately equal. Two methods were used to provide a check on the accuracy of the results.

Analysis in this appendix shows that it is possible to create a spring from titanium or aluminum that will launch an 11.72 kg load of regolith at 12 m/s. For a spring compression distance of 0.5 m, the spring constant has to be approximately 6750 N/m to achieve the needed velocity.

Assumptions:

- 1) The motor is connected directly to a throwing arm.
- 2) The release angle is 45° , therefore there are only 45° of rotation in which to accelerate the regolith.
- 3) The throwing arm is massless.
- 4) The regolith is a point mass
- 5) The motor provides a constant torque and acceleration

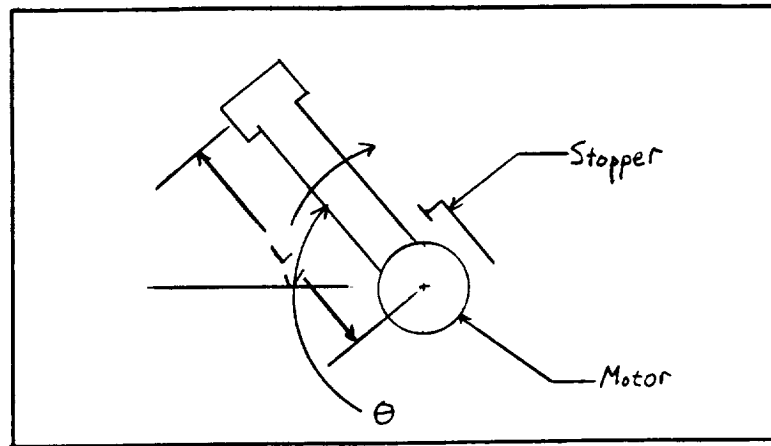

Figure F1. Direct connection throwing solution

Nomenclature:

- L = length of throwing arm
- V = required linear launch velocity
- ω = required rotational launch velocity
- I = effective moment of inertia
- ρ = density of regolith thrown
- $\#$ = volume of regolith thrown
- T = required motor torque
- θ = angle of rotation

Methodology:

Derive the torque as a function of volume thrown and launch velocity to discover the required motor torque for this arrangement.

Analysis:

$$V = L\omega \quad (F1)$$

$$T = I\alpha \quad (F2)$$

$$\omega^2 = 2\alpha\theta \quad (F3)$$

Substitute (F1) and (F2) into (F3) gives

$$V = \sqrt{\frac{L^2 2\theta T}{I}} \quad (F4)$$

$$I = \rho V L^2 \quad (F5)$$

Substitute (F5) into (F4) and rearrange for T yields

$$T = \rho V^3 / 2\theta$$

Conclusion :

For values of

$$\rho = 1465 \text{ kg/m}^3$$

$$V = 8 \times 10^{-3} \text{ m}^3$$

$$v = 12 \text{ m/s}$$

$$\theta = 45^\circ \left(\frac{\pi}{4}\right)$$

$$T = 1074 \text{ N-m}$$

Spring Motor Arrangement

Assumptions:

- 1) Spring is massless
- 2) No damping
- 3) linear spring ; $F=kx$

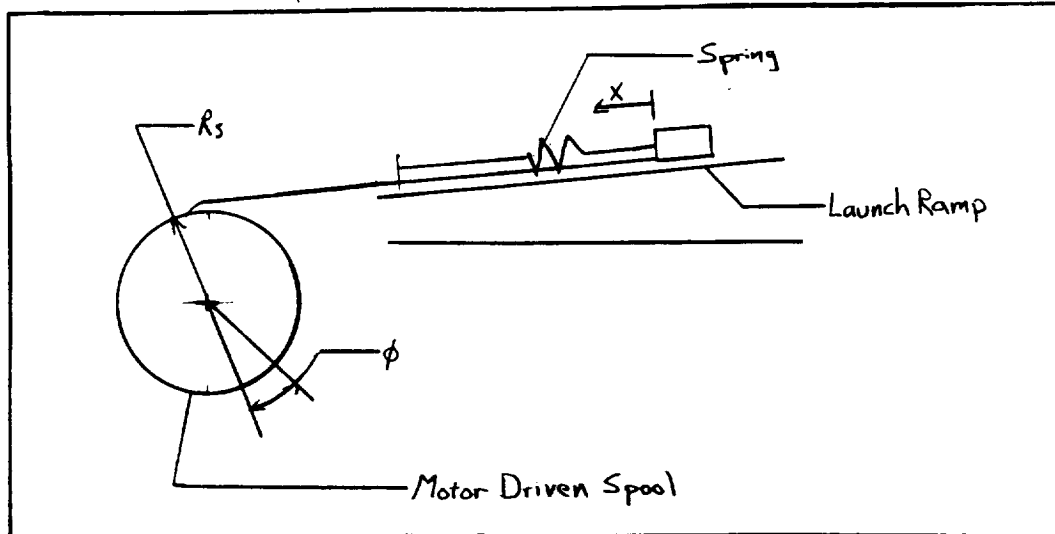

Figure F2. Spring motor arrangement.

Nomenclature:

T = motor torque

ϕ = angle spool is rotated, may be greater than 2π

k = spring constant

x = distance spring compressed.

v_0 = required launch velocity

$\#$ = volume of regolith thrown

r_s = radius of winding spool

Methodology:

Calculate the motor torque as a function of launch velocity and ϕ .

Analysis:

$$T = F \cdot R_s = kx \cdot R_s \quad (F6)$$

$$x = R_s \phi \quad (F7)$$

Substitute (F7) into (F6) and solve for T

$$T = kx^2 / \phi \quad (F8)$$

$$\text{acceleration} = kx / \rho \psi \quad (F9)$$

$$v_0^2 = 2kx^2 / \rho \psi \quad (F10)$$

Substitute (F10) into (F9) to yield

$$T = v_0^2 \rho \psi / 2\phi \quad (F11)$$

Conclusion:

Because $\phi = x/R_s$, the required torque of the motor can be decreased by decreasing R_s .

The following chart was plotted using values of

$$v_0 = 12 \text{ m/s}$$

$$\rho = 1465 \text{ kg/m}^3$$

$$\psi = 8 \times 10^{-3} \text{ m}^3$$

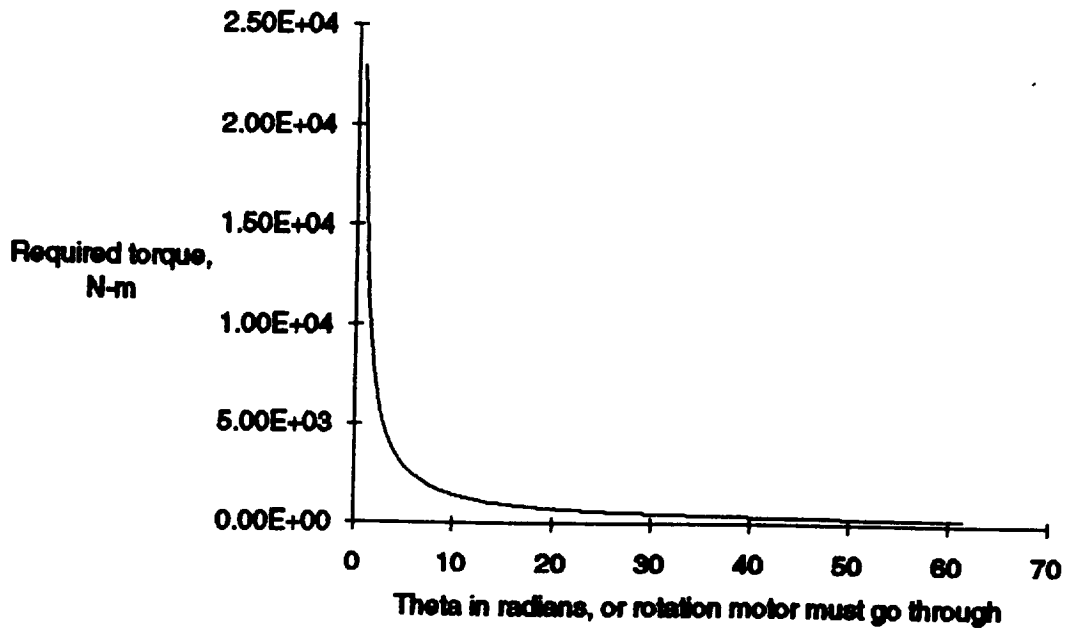

Figure F3. Required torque to compress spring as a function of the number of rotations it undergoes.

Flywheel system powered by electric motor

Assumptions:

- 1) Point mass
- 2) Some values will be chosen arbitrarily during the Analysis
- 3) geometry of the flywheel

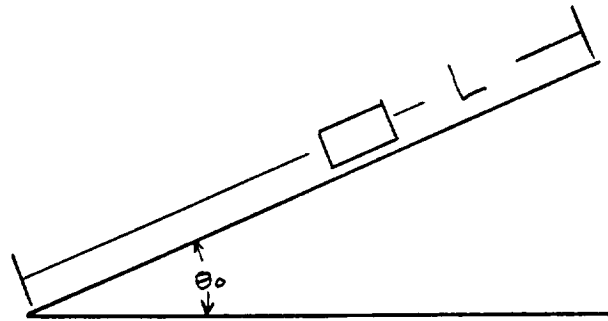

Figure F4. Launch geometry.

Nomenclature:

E = energy

KE = kinetic energy

PE = potential energy

ρ = density of regolith

V = volume of regolith thrown

L = length of throw ramp

θ_0 = launch angle

ω = rotational velocity of flywheel

Methodology:

Calculate the energy that needs to be added to the regolith and choose a flywheel that will supply that energy to reduce the power required.

Analysis:

$$E = KE + PE = p\psi \left(\frac{1}{2} v_0^2 + gL \sin \theta_0 \right) \quad (F12)$$

Need to design a flywheel that adds this much energy.

$E =$ area under $T-\phi$ curve

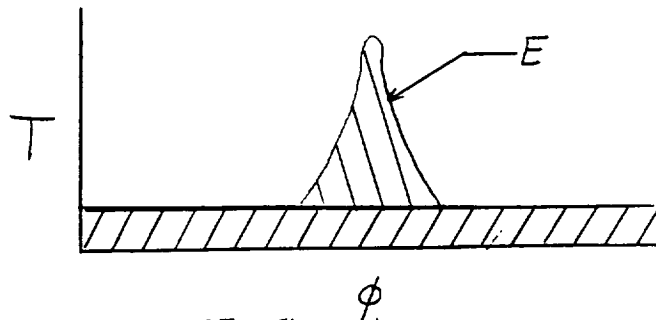

Figure F5. Flywheel energy.

Assume that the flywheel is hooked directly to the motor.

$$E = E_{\text{motor}} + E_{\text{flywheel}} \quad (F13)$$

$$E_{\text{flywheel}} = \frac{1}{2} I (\omega_{\text{max}}^2 - \omega_{\text{min}}^2) \quad (F14)$$

$$E_m = T \Delta \phi \quad (F15)$$

Substitute (F14) and (F15) into (F13) and combine with (F12) yields

$$p\psi \left(\frac{1}{2} v_0^2 + gL \sin \theta_0 \right) = T \Delta \phi + \frac{1}{2} I (\omega_{\text{max}}^2 - \omega_{\text{min}}^2) \quad (F16)$$

Arbitrary assumptions to complete analysis

$$L = .5m$$

$$\omega_{max} = 1.25\omega_{min}$$

Approximate flywheel as

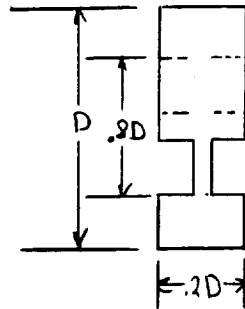
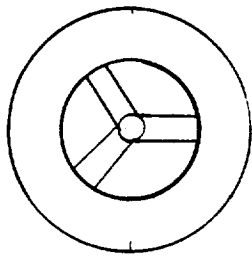

Ignore contribution of spokes

Assume Steel flywheel

$$I = \frac{\pi (d_o^4 - d_i^4) L \rho}{32} = \frac{\pi (D^4 - (.8D)^4) (.2D) \times 7700}{32}$$

$$M = \rho \frac{\pi}{4} (D^2 - (.8D)^2) (.2D)$$

Conclusions:

If the flywheel is steel $\rho = 7700 \text{ kg/m}^3$

$$\rho = 1465 \text{ kN/m}^3$$

$$V = 8E-3 \text{ m}^3$$

Figure F7 shows a plot of T vs D . Figure F6 shows a plot of the mass required as a function of torque. An investigation of these charts show that an effective flywheel must have a large mass and a prohibitively large diameter.

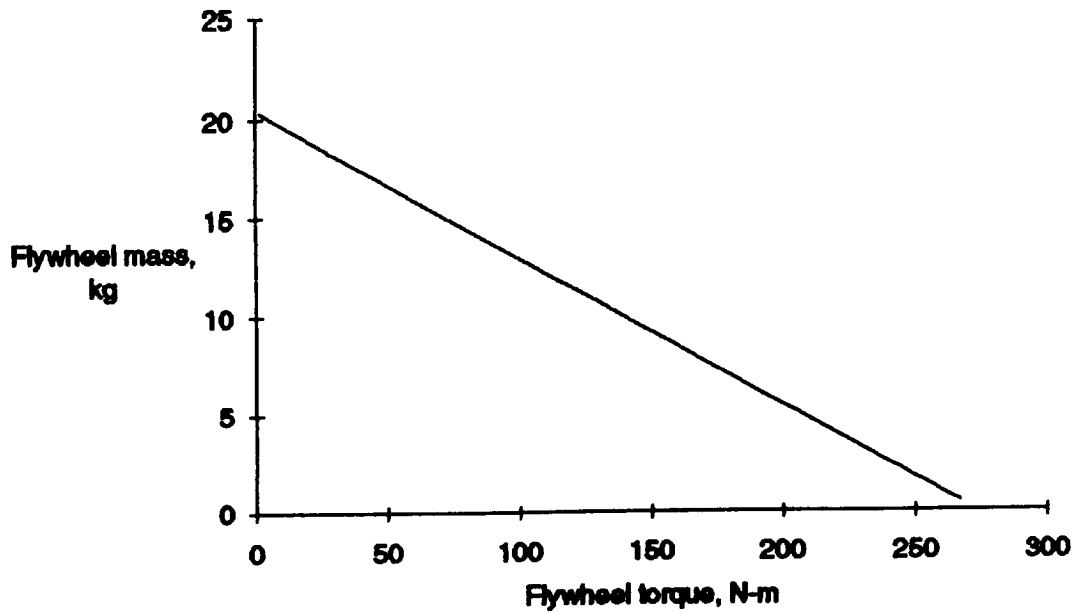

Figure F6. Flywheel mass as a function of the torque required.

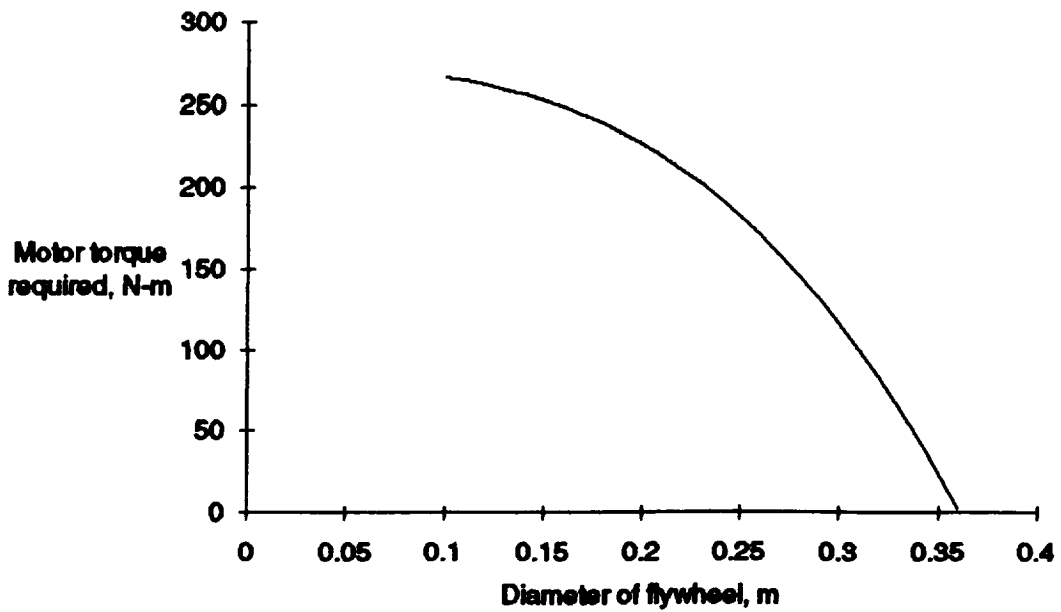
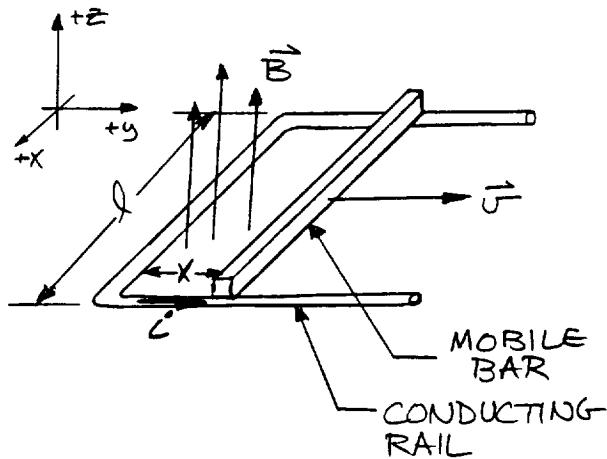

Figure F7. Motor torque as a function of flywheel diameter.

RAIL GUN (MAGNETIC ENERGIZING) FEASIBILITY STUDY

LENZ'S LAW OF INDUCTION:
AN INDUCED CURRENT IN A CLOSED
CONDUCTING LOOP WILL APPEAR
IN SUCH A DIRECTION THAT IT
OPPOSES THE CHANGE THAT
PRODUCED IT.



$\vec{v} \sim$ BAR VELOCITY
 $\vec{B} \sim$ FLUCTUATING
 MAGNETIC FIELD
 $l \sim$ RAIL SEPARATION
 $i \sim$ INDUCED CURRENT

FBD OF BAR

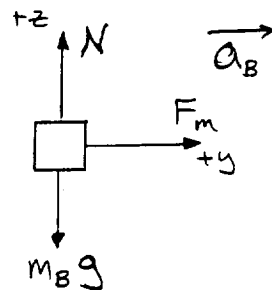

$F_m \sim$ MAGNETIC FORCE
 $M_B \sim$ BAR MASS
 $a_B \sim$ BAR ACCELERATION

$$F_m = m_B a_B = i l B = \frac{\mathcal{E}}{R} l B$$

$\mathcal{E} \sim \text{EMF}$

$R \sim \text{RAIL RESISTANCE}$

$$\mathcal{E} = \frac{d}{dt} (Blx) = Bl \frac{dx}{dt} = Blv$$

$$\therefore F_m = \frac{B^2 l^2 v}{R}$$

(F16)

NEXT : IF RAILS AT AN ANGLE AND BAR REPLACED BY REGOLITH LOAD...

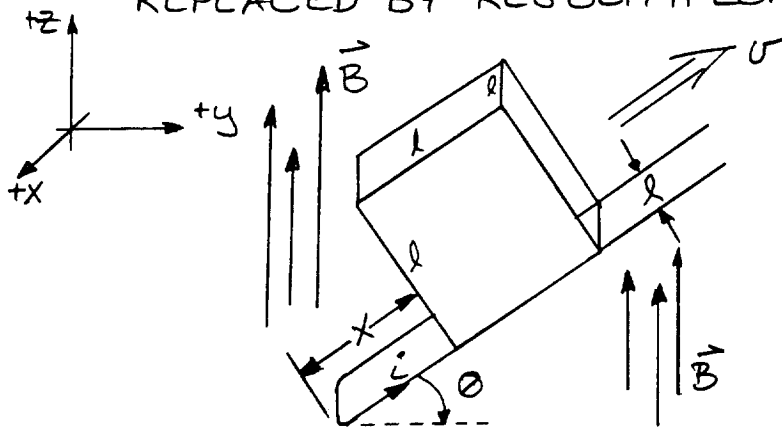

$\theta \sim \text{LAUNCH ANGLE}$

FBD

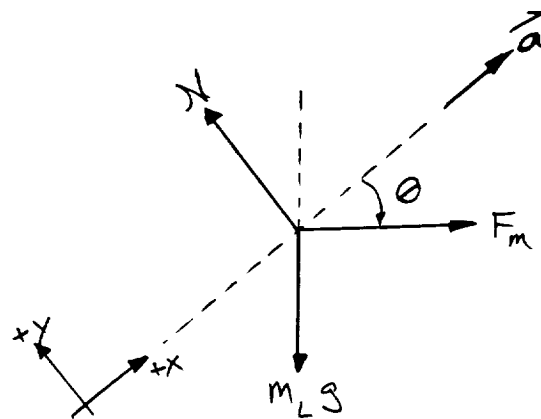

$$\Sigma F_x = ma$$

$$m_L g \sin \theta - F_m \cos \theta = m_L a$$

$$\text{BUT } F_m = \frac{B^2 l^2 v}{R} \cos \theta \quad \text{BY EQN. (F16)}$$

$$m_L g \sin \theta - \frac{B^2 l^2 v}{R} \cos^2 \theta = m_L a = m_L \frac{dv}{dt}$$

$$m_L \frac{dv}{dt} + \underbrace{\frac{B^2 l^2 \cos^2 \theta}{R}}_{=K} v = m_L g \sin \theta$$

$$v' + \underbrace{\frac{B^2 l^2 \cos^2 \theta}{R m_L}}_{K_1} v = g \sin \theta$$

$$\therefore v' + K_1 v = g \sin \theta, \quad \text{WHERE } K_1 = \frac{B^2 l^2 \cos^2 \theta}{R m_L}$$

$$\text{SOLVE HOMOGENOUS: } v' + K_1 v = 0$$

$$\text{LET } v = e^{rt}, \quad v' = r e^{rt}$$

$$\therefore r e^{rt} + K_1 e^{rt} = 0$$

$$\therefore r = -K_1$$

$$\rightarrow v = C_1 e^{-K_1 t} \quad \leftarrow v_h$$

$$\text{LET } v_p = At + B; \quad v_p' = A$$

$$A + K_1 (At + B) = g \sin \theta$$

$$K_1 At = 0 \rightarrow A = 0$$

$$A + K_1 B = g \sin \theta \rightarrow B = \frac{g \sin \theta}{K_1}$$

$$\therefore v = C_1 e^{-K_1 t} + \frac{g \sin \theta}{K_1}$$

$$\text{AT } t=0, v=0$$

$$0 = C_1 e^0 + \frac{g \sin \theta}{K_1}$$

$$\therefore C_1 = -\frac{g \sin \theta}{K_1}$$

$$\therefore v = -\frac{g \sin \theta}{K_1} e^{-K_1 t} + \frac{g \sin \theta}{K_1} \quad (\text{F17})$$

$$K_1 = \frac{B^2 l^2 \cos^2 \theta}{R m_L}$$

$$P = F_m v, \text{ WHERE } F_m \text{ FROM EQN (F16)}$$

$$P = \frac{B^2 l^2 \cos \theta}{R} v^2 = \frac{B^2 l^2 \cos \theta}{R} \cdot \frac{g^2 \sin^2 \theta}{(K_1)^2} [1 - e^{-K_1 t}]^2$$

$$P = \frac{R g^2 m_L^2 \sin^2 \theta}{B^2 l^2 \cos^3 \theta} \left[1 - e^{\left(\frac{-B^2 l^2 \cos^2 \theta}{R m_L} \right) t} \right]^2$$

→ INSTANTANEOUS POWER NEEDED TO PROPEL LOAD MAGNETICALLY.

$$\frac{dx}{dt} = \frac{ds}{dt} = v \rightarrow ds = v dt \rightarrow s = \int v dt$$

SN POSITION (i.e. DISTANCE TRAVELED ALONG RAILS)

$$s = \frac{g \sin \theta}{K_1} \int_0^t [1 - e^{-K_1 t'}] dt'$$

$$= \frac{g \sin \theta}{K_1} \left\{ t' \Big|_0^t + \frac{1}{K_1} e^{-K_1 t'} \Big|_0^t \right\}$$

$$s = \left[t + \frac{1}{K_1} (e^{-K_1 t} - 1) \right] \left(\frac{g \sin \theta}{K_1} \right)$$

WORK = $F_m \cdot s \rightarrow$ AVERAGE POWER = $W/\Delta t$

$$W = \frac{B^2 l^2 \cos \theta}{R} v \cdot s$$

$$= \frac{B^2 l^2 \cos \theta}{R} \left[\frac{g \sin \theta}{K_1} (1 - e^{-K_1 t}) \right] \left[t + \frac{1}{K_1} (e^{-K_1 t} - 1) \right] \cdot \left(\frac{g \sin \theta}{K_1} \right)$$

$$\therefore W = \frac{B^2 l^2 \cos \theta g^2 \sin^2 \theta}{R K_1} (1 - e^{-K_1 t}) \left[t + \frac{1}{K_1} (e^{-K_1 t} - 1) \right]$$

WHERE $K_1 = B^2 l^2 \cos^2 \theta / R m_L$

IF $B = 0.1 \text{ T}$, $t = 15 \text{ s} \rightarrow v = 20.86 \text{ m/s}$, $s = \underline{\underline{141.76 \text{ m}}}$

FEASIBILITY OF A LINEAR SPRING AS THROWING METHOD

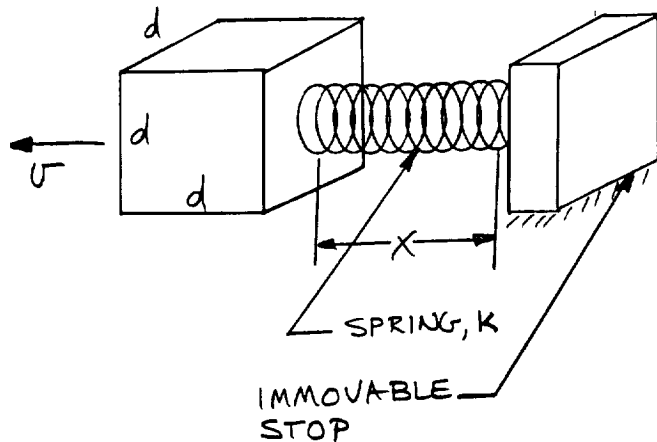

d ~ SIDE DIMENSION
 OF REGOLITH LOAD
 v ~ LAUNCH VELOCITY
 x ~ SPRING
 COMPRESSION
 DISTANCE
 K ~ SPRING CONSTANT
 (ASSUME LINEAR
 SPRING)

CONSERVATION OF ENERGY

$$\frac{1}{2} m v^2 = \frac{1}{2} k x^2$$

$$m = \rho d^3$$

$$k = m \left(\frac{v}{x} \right)^2 ; \quad x = \sqrt{\frac{m}{k}} v$$

(F18)

WORK TO ENERGIZE SPRING:

$$W = \Delta KE = \frac{1}{2} m v^2 = \frac{1}{2} k x^2$$

→ REDUCE POWER TO ENERGIZE SPRING BY
LOADING SLOWLY.

EXAMPLE, WITH TYPICAL NUMBERS:

LET: $d = 0.3 \text{ m}$

$\rho = 3.1 \text{ g/cm}^3 = 3100 \text{ kg/m}^3$

$m = 83.7 \text{ kg}$

$v = 25 \text{ m/s}$

$x \text{ [m]}$	$k \text{ [N/m]}$	$W \text{ [J]}$
0.1	5.23×10^6	26150
0.25	8.37×10^5	26156.25
0.5	2.09×10^5	26125
0.75	9.3×10^4	26156.25
1.00	5.23×10^4	26150

CYLINDRICAL HELICAL SPRING, CIRCULAR CROSS-SECTION:

$$P_m = \frac{\pi d^3 S_s}{16 r k_m}$$

$P_m \sim$ SAFE LOAD

$d \sim$ WIRE DIAMETER

$S_s \sim$ SAFE SHEARING STRESS

$r \sim$ MEAN COIL RADIUS

$$U = \frac{P_m f}{2} = \frac{S_s^2 V}{4 G k_m^2}$$

$U \sim$ RESILIENCE [N·m]

$V \sim$ SPRING VOLUME

$G \sim$ SHEAR MODULUS (MODULUS OF RIGIDITY)

$$f = \frac{64 n r^3 P}{d^4 G} = \frac{4 \pi n r^2 S_s}{d G k_m} \quad f \sim \text{DEFLECTION AT LOAD } P$$

$$k = \frac{Gd^4}{64nr^3}$$

$k \sim$ SPRING CONSTANT
 $n \sim$ NUMBER OF COILS

N.B. THIS EQUATION ASSUMES
 A LINEAR SPRING.

WAHL FACTOR, K_w

$$K_w = K_m \approx 1; \text{ FOR "LIGHT" SPRINGS}$$

$$= \left[\frac{(4C-1)}{(4C-4)} \right] + \frac{0.615}{C}; \quad C = \frac{2r}{d};$$

FOR HEAVY, CLOSELY COILED.

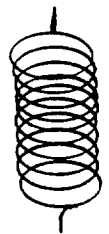

SIDE

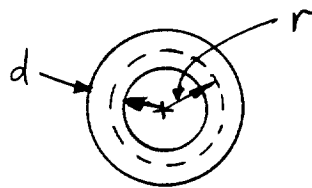

END

TORSIONAL (SHEAR STRESS)

$$\tau = \frac{8P(2r)}{\pi d^3} = \frac{16Pr}{\pi d^3}$$

* MULTIPLIED BY $K_m = K_w$ TO GIVE TOTAL
 RESULTANT SHEAR STRESS (ON
 INSIDE OF COIL).

IF LET $\tau' = \tau / (\text{S.F.}) = S_v \approx$ ALLOWABLE SHEAR STRESS

$$\therefore P_{\text{MAX}} = \frac{\tau' \pi d^3}{16r} = \frac{\tau \pi d^3}{16r (\text{S.F.})}; \quad \text{S.F.} \sim \text{SAFETY FACTOR}$$

$\tau \sim$ ULTIMATE SHEAR

$$\tau \approx 0.43 \times S_{UT}$$

[MARK'S HANDBOOK, p 8-79]

WHERE S_{UT} ~ ULTIMATE TENSILE STRENGTH

LOOK AT Al AND Ti ALLOYS AS POSSIBLE MATERIALS FOR LUNAR USE.

	<u>Al ALLOYS</u>	<u>Ti ALLOYS</u>
G	$3.76 \times 10^6 - 3.9 \times 10^6$ psi (25.51 - 26.89 GPa)	6.5×10^6 psi (44.82 GPa)
E	$9.9 \times 10^6 - 10.3 \times 10^6$ psi (68.3 - 71.0 GPa)	$15.0 \times 10^6 - 16.0 \times 10^6$ psi (103 - 110 GPa)

Ti \rightarrow OFFERS HIGHER SPRING CONSTANT, K, FOR SPRING OF GIVEN SIZE.

EXAMPLES: $\frac{64k}{G} = \frac{d^4}{nr^3}$; $n = \frac{d^4}{r^3} \times \frac{G}{64k}$; $d = \left(\frac{64knr^3}{G} \right)^{1/4}$

IF: USE Ti, $k = 2 \times 10^5$ N/m, $G = 44.8$ GPa,
 $d = 0.01$ m, $r = 0.05$ m
 $\rightarrow n = 0.28$ COILS

IF: USE Ti, $n = 20$ COILS, $k = 2 \times 10^5$ N/m, $G = 44.8$ GPa,
 $r = 0.05$ m
 $\rightarrow d = 0.029$ m = 2.9 cm

DYNAMICS ANALYSIS

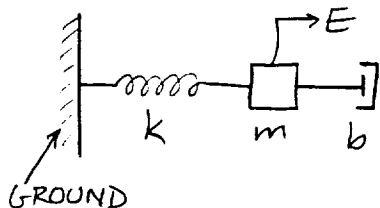

$k \sim$ SPRING CONSTANT
 $m \sim$ MASS
 $b \sim$ DAMPING COEFF.
 $E \sim$ INPUT FORCE

BOND GRAPH

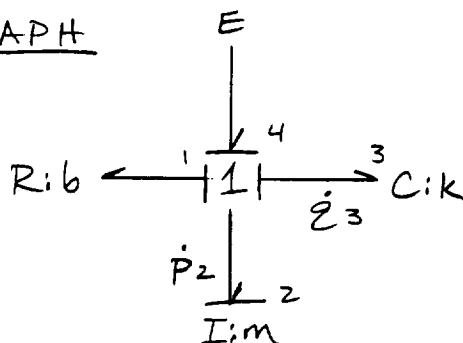

STATE VARIABLES: p_2, q_3

CONSTITUTIVE EQNS.

$$\begin{aligned}
 e_1 &= R f_1 \\
 f_2 &= \frac{1}{I_2} p_2 \\
 e_3 &= \frac{1}{C_3} q_3 \\
 e_4 &= E
 \end{aligned}$$

JUNCTION EQN.

$$\begin{aligned}
 e_1 + e_3 + e_2 &= E \\
 f_2 = f_1 = f_3 = f_4
 \end{aligned}$$

$$\dot{p}_2 = e_2 = E - e_1 - e_3 = E - R f_1 - \frac{1}{C_3} q_3$$

$$= E - R f_2 - \frac{1}{C_3} q_3 = E - \frac{R}{I_2} p_2 - \frac{1}{C_3} q_3$$

$$\dot{q}_3 = f_3 = f_2 = \frac{1}{I_2} p_2$$

$$R \rightarrow b, I_2 \rightarrow m, q \rightarrow x, \dot{q} \rightarrow \dot{x}, p \rightarrow m\dot{v}, \dot{p} \rightarrow m\ddot{x}, C \rightarrow \frac{1}{k}$$

$$m \ddot{x} = E - \frac{b}{m} \cdot m \dot{x} - kx \rightarrow \underline{\underline{m \ddot{x} + b \dot{x} + kx = E}} \quad (\text{F19})$$

NOTE: IF SPRING LOSSES, SUCH AS FRICTIONAL OR HYSTERIS, ARE NEGLIGIBLE, THEN $b=0$.

LET $E=0$ AND APPLY BOUNDARY CONDITIONS
 $x(t=0) = x_d \leftarrow$ INITIAL COMPRESSION OF SPRING (FOR EXAMPLE, $x_d = -0.5 \text{ m}$)

$$\dot{x}(t=0) = 0$$

FROM EQUATION (F19)

$$\ddot{x} + \frac{b}{m} \dot{x} + \frac{k}{m} x = 0$$

$$\text{LET } x = e^{rt}, \dot{x} = r e^{rt}, \ddot{x} = r^2 e^{rt}$$

$$r^2 + \frac{b}{m} r + \frac{k}{m} = 0 \rightarrow r = \frac{-\frac{b}{m} \pm \sqrt{\frac{b^2}{m^2} - \frac{4k}{m}}}{2m}$$

$$r = \frac{-\frac{b}{m} \pm \frac{1}{2} \sqrt{\frac{b^2 - 4km}{m^2}}}{2m} = \frac{-\frac{b}{m} \pm \sqrt{b^2 - 4km}}{2m}$$

$$r = \frac{-b \pm (b^2 - 4km)^{1/2}}{2m}$$

IF LET $b=0$:

$$r = \pm \frac{(-4km)^{1/2}}{2m} = \pm \left(\frac{-k}{m}\right)^{1/2} = \pm j \sqrt{\frac{k}{m}} ; j = \sqrt{-1}$$

$$\therefore x(t) = C_1 e^{j\sqrt{\frac{k}{m}}t} + C_2 e^{-j\sqrt{\frac{k}{m}}t}$$

EULER'S EQUATION: $e^{j\alpha} = \cos \alpha + j \sin \alpha$

$$\therefore x(t) = C_1 (\cos \sqrt{\frac{k}{m}} t + j \sin \sqrt{\frac{k}{m}} t) + C_2 (\cos -\sqrt{\frac{k}{m}} t + j \sin -\sqrt{\frac{k}{m}} t)$$

$$\dot{x}(t) = C_1 \left[-\sqrt{\frac{k}{m}} \sin \sqrt{\frac{k}{m}} t + j \sqrt{\frac{k}{m}} \cos \sqrt{\frac{k}{m}} t \right] + C_2 \left[\sqrt{\frac{k}{m}} \sin -\sqrt{\frac{k}{m}} t - j \sqrt{\frac{k}{m}} \cos -\sqrt{\frac{k}{m}} t \right]$$

TRIG. IDENTITIES:

$$\cos(\theta) = \cos(-\theta)$$

$$\sin(\theta) = -\sin(-\theta) \rightarrow -\sin \theta = \sin(-\theta)$$

$$\therefore x(t) = C_1 \cos \sqrt{\frac{k}{m}} t + C_1 j \sin \sqrt{\frac{k}{m}} t + C_2 \cos \sqrt{\frac{k}{m}} t - j C_2 \sin \sqrt{\frac{k}{m}} t.$$

$$\underline{\underline{x(t) = (C_1 + C_2) \cos \sqrt{\frac{k}{m}} t + j(C_1 - C_2) \sin \sqrt{\frac{k}{m}} t}}$$

$$\dot{x}(t) = -C_1 \sqrt{\frac{k}{m}} \sin \sqrt{\frac{k}{m}} t + j C_1 \sqrt{\frac{k}{m}} \cos \sqrt{\frac{k}{m}} t - C_2 \sqrt{\frac{k}{m}} \sin \sqrt{\frac{k}{m}} t - j C_2 \sqrt{\frac{k}{m}} \cos \sqrt{\frac{k}{m}} t$$

$$\underline{\underline{\dot{x}(t) = -\sqrt{\frac{k}{m}}(C_1 + C_2) \sin \sqrt{\frac{k}{m}} t + j \sqrt{\frac{k}{m}}(C_1 - C_2) \cos \sqrt{\frac{k}{m}} t}}$$

$$\underline{\underline{\ddot{x}(t) = -\left(\frac{k}{m}\right)(C_1 + C_2) \cos \sqrt{\frac{k}{m}} t - j \left(\frac{k}{m}\right)(C_1 - C_2) \sin \sqrt{\frac{k}{m}} t}}$$

NOW APPLY BOUNDARY CONDITIONS

$$x(t=0) = x_d$$

$$\dot{x}(t=0) = 0$$

$$x(t=0) = x_d = (C_1 + C_2) \cos(0) + j(C_1 - C_2) \sin(0)$$

$$\Rightarrow x_d = C_1 + C_2$$

$$\dot{x}(t=0) = 0 = -\sqrt{\frac{k}{m}}(C_1 + C_2) \sin(0) + j\sqrt{\frac{k}{m}}(C_1 - C_2) \cos(0)$$

$$\Rightarrow 0 = j\sqrt{\frac{k}{m}}(C_1 - C_2) \rightarrow \underline{C_1 = C_2}$$

$$\therefore \underline{C_1 = C_2 = \frac{1}{2} x_d}$$

$$x(t) = x_d \cdot \cos\left(\sqrt{\frac{k}{m}} t\right) \quad [m]$$

$$v(t) = -x_d \cdot \sqrt{\frac{k}{m}} \cdot \sin\left(\sqrt{\frac{k}{m}} t\right) \quad [m/s]$$

$$a(t) = -x_d \cdot \left(\frac{k}{m}\right) \cdot \cos\left(\sqrt{\frac{k}{m}} t\right) \quad [m/s^2]$$

m ~ LAUNCH MASS

k ~ SPRING CONSTANT

x_d ~ SPRING COMPRESSION DISTANCE

N.B. DYNAMIC RESULTS MATCH-UP NEARLY IDENTICALLY TO WORK-ENERGY RESULTS.

SPRING PROPERTIES FOR LUNAR SYSTEM

KNOWN:

LAUNCH VOLUME = $0.2\text{m} \times 0.2\text{m} \times 0.2\text{m}$
AT 11.72kg (SEE APPENDIX K)

COMPRESSION DISTANCE = 0.5m
DUE TO GEOMETRICAL CONSTRAINTS

LAUNCH VELOCITY = 12m/s (MAXIMUM)

BY EQUATION (F18)

$$k = m_L \left(\frac{v}{x} \right)^2 = 11.72 \left(\frac{12}{0.5} \right)^2$$

$k \approx 6750 \text{ N/m}$

APPENDIX G

Volume of Regolith Needed to Cover Habitat

One of the early steps in the quantitative analysis was calculating the volume of regolith required to cover the habitat. The volume required is dependent on a number of factors based on the geometry and positioning of the habitat and the angle of repose of regolith. The volume of regolith was important both for discovering how much regolith had to be moved as well as investigating the amount of regolith that will be on the habitat. This appendix contains an analysis and calculation of the volume of regolith required. The volume required to cover the habitat is 3142 m³ of regolith.

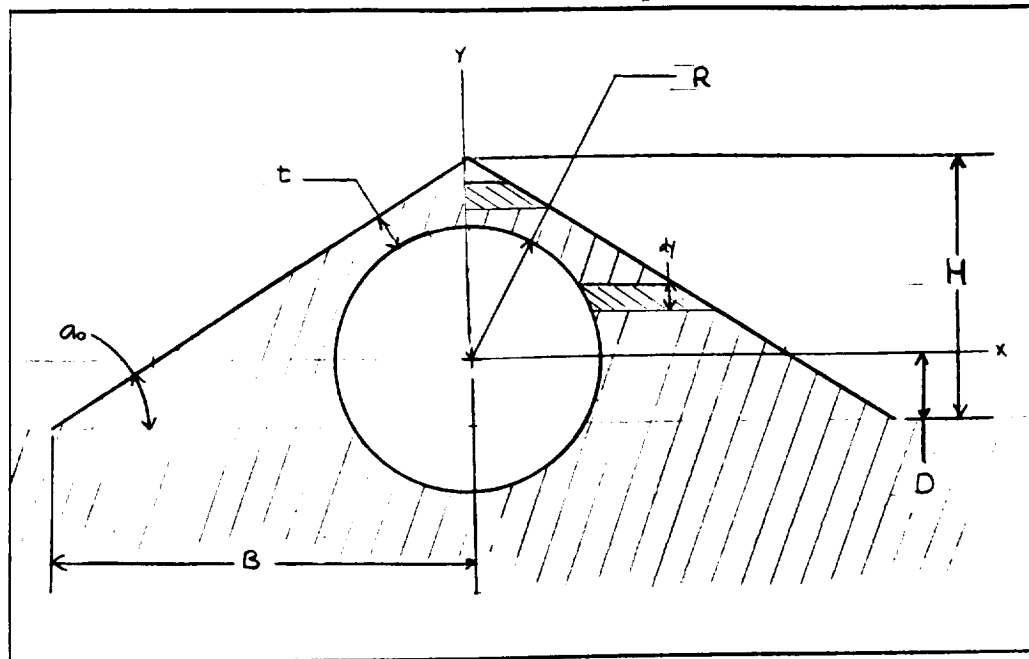

Figure G1. Variable definition for volume of regolith

Assumptions: calculation

- 1) The habitat is more than half exposed.
- 2) The regolith covers the sphere in a cone that rises at the angle of repose.

Nomenclature:

a_0 = angle of repose

t = required thickness of regolith to provide adequate radiation protection

B = radius of cone; distance from center of habitat to edge of regolith.

R = radius of habitat

H = height of cone

D = distance center of habitat above the ground.

V = Volume of regolith

Methodology:

Integrate volume using method of washers.

Analysis:

$$V = \int_a^b \pi [f(y)^2 - g(y)^2] dy \quad (G1)$$

from $-D$ to R

$$f(y) = \frac{B}{H}(H-y-D)$$

$$g(y) = \sqrt{R^2 - y^2}$$

from R to $H-D$

$$f(y) = \frac{B}{H}(H-y-D)$$

$$g(y) = 0$$

$$V = \int_{-D}^R \pi \left[\left(\frac{B}{H}(H-y-D) \right)^2 - \left(\sqrt{R^2 - y^2} \right)^2 \right] dy \\ + \int_R^{H-D} \pi \left[\left(\frac{B}{H}(H-y-D) \right)^2 \right] dy$$

$$V = \pi \left(\frac{B^2 H}{3} - \frac{2R^3}{3} - R^2 D + \frac{D^3}{3} \right) \quad (G2)$$

B and H are geometrical properties which depend on the configuration of the habitat and the angle of repose.

$$B = (R+t)/\sin a_0 + D/\tan a_0 \quad (63)$$

$$H = (R+t)/\cos a_0 + D \quad (64)$$

Values used.

$$a_0 = 37^\circ$$

$$t = .5m$$

$$R = 8m$$

$$D = 3.123m$$

Using equations (62), (63) and (64) gives

$$B = 18.3m$$

$$H = 13.8m$$

$$V = 3142 m^3$$

APPENDIX H

Determination of Size of Lunar Device Fleet

This appendix contains the analysis to determine the number of lunar devices in a fleet. A plot was made of volumetric rate of regolith collection per device. This plot shows that above ten lunar devices there is not a very large gain in lower rates of collection. Below ten lunar devices, the collection rate increases and a degree of redundancy is lost. If one of the ten devices fails, then the regolith collection rate will not have to increase much to ensure coverage of the lunar habitat in one lunar day. If one out of two lunar devices failed then the collection rate will have to greatly increase. Ten units provides a reasonable collection rate and a high degree of redundancy.

ANALYSIS TO DETERMINE NUMBER OF LUNAR DEVICES

KNOWN:

- NEED 3142 m^3 OF REGOLITH TO SUFFICIENTLY COVER HABITAT.
- DO COVERAGE IN ONE LUNAR DAY (14 EARTH DAYS). WITH THIS TIME PERIOD THERE IS NO NEED TO WORRY ABOUT NIGHT STORAGE OR OPERATION.

LET T = TIME FOR COMPLETION
= 1 LUNAR DAY = 1209600 SECONDS
 V_T = TOTAL VOLUME OF REGOLITH NEEDED FOR COVERAGE.
= 3142 m^3
 X = NUMBER OF DEVICES.

REGOLITH NEEDED/SECOND/DEVICE

$$\frac{V_T}{T \cdot X} = \frac{2.598 \times 10^{-3} \text{ m}^3}{\text{S. DEVICE}} \quad (H1)$$

Volumetric Rate of Collection/Device vs. # of Devices

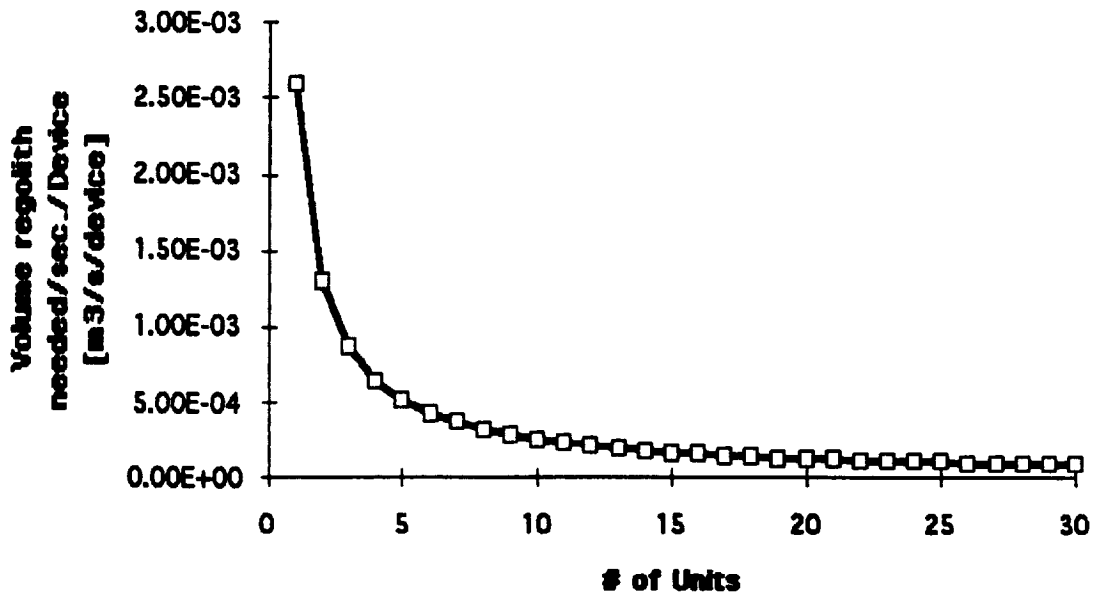

PLOT OF EQUATION (H 1) .

ABOVE PLOT SHOWS :

(i) PAST 10 DEVICES, NOT MUCH GAIN IN A LOWER RATE OF REGOLITH COLLECTION.

(ii) IF ONE DEVICE FAILS, THE INCREASE IN REGOLITH COLLECTION RATE IS NOT TOO GREAT.

[FOR EXAMPLE ; IF USED TWO UNITS AND ONE FAILED, COLLECTION RATE WILL HAVE TO DRASTICALLY INCREASE.

$$\text{AT } X=10 \text{ , } \frac{V_T}{T \cdot X} = 2.598 \times 10^{-4} \text{ m}^3/\text{s}/\text{DEVICE}$$

APPENDIX I

Nominal Power of Single Lunar Device

This appendix presents an analysis of the nominal power required for a single device. The model chosen for this analysis is configuration 1 as shown in the text of the report. Because this configuration requires that the device gather and throw at separate intervals it was important to discover the optimal amount of time spent gathering soil and compacting the spring. This optimal time arrangement provides for a minimal power requirement. In addition to being based on configuration 1, this analysis also assumes ten units and that the job is to be completed in one lunar day.

Assumptions:

- 1) The amount of time spent "throwing" the regolith is small when compared to the amount of time spent gathering the regolith and compressing the spring.
- 2) This derivation is based on design solution 1. Therefore, the device does not gather regolith and compress the spring at the same time.

Nomenclature:

- P = total continuous power required, per cycle
 P_c = Power needed to compress the spring
 P_r = Power needed to move the device and gather the regolith.
 F = Force required to move the device
 F_d = Force required to gather the regolith
 F_R = Force required to overcome rolling resistance
 \dot{V} = Volumetric rate that the device must move regolith at.
 B = scraper blade width
 h = depth of cut that scraper makes
 t = time of one cycle, gather and throw.
 ρ = regolith density
 n = inverse of the fraction of time, t , spent gathering
 v_0 = launch velocity required of regolith
 k = spring constant
 x = distance spring is compacted.
 V = Volume of regolith thrown
 v_{el} = Velocity device moves at.
 D = distance traveled by device

Methodology:

The goal is to find the ratio of time spent collecting to the time spent throwing to minimize the power required.

Analysis:

$$P = P_c + P_r \quad (I1)$$

$$P_r = F \cdot v_{el} \quad (I2)$$

$$\Psi = B \cdot D \cdot h \quad (I3)$$

$$D = \Psi / Bh \quad (I4)$$

$$v_{el} = D/t = \Psi / Bht \quad (I5)$$

$$\dot{\Psi} = \Psi/t \quad (I6)$$

$$P_r = F \cdot \Psi / Bht \quad (I7)$$

But, only a fraction of t , $\frac{1}{n}t$ is available to gather
so

$$P_r = F \cdot \frac{\Psi}{Bht} \quad (I8)$$

Substituting (I6) into (I8) gives

$$P_r = \frac{F \dot{\Psi}}{Bh} \quad (I9)$$

From analysis in Appendix F

$$P_c = \frac{kx^2}{t} \quad (I10)$$

and

$$k = \rho \dot{V} \left(\frac{V_0}{x} \right)^2 \quad (I11)$$

Substituting (I11) into (I10) yields

$$P_c = \frac{\rho \dot{V} V_0^2}{t} \quad (I12)$$

noting that only the fraction of t , $\left(\frac{n-1}{n}\right)t$, is still available to compress and substituting (I6) yields

$$P_c = \frac{\rho \dot{V} V_0^2 n}{n-1} \quad (I13)$$

$$P = \frac{F \dot{V} n}{Bh} + \frac{\rho \dot{V} V_0^2 n}{n-1} \quad (I14)$$

to minimize P and find n ;

$$\frac{\partial P}{\partial n} = \frac{F \dot{V}}{Bh} + \frac{\rho \dot{V} V_0^2}{n-1} - \frac{n \rho \dot{V} V_0^2}{(n-1)^2} = 0 \quad (I15)$$

Equation (I15) requires a numerical solution. Using previous analysis and the model as it is designed gives

$$B = .4 \text{ m}$$

$$h = .05 \text{ m}$$

$$F = F_d + F_R = 60.8 + 422.12 = 483 \text{ N}$$

$$\dot{V} = 2.598 \times 10^{-4} \text{ m}^3/\text{s}$$

$$\rho = 1465 \text{ kg/m}^3$$

$$V_0 = 12 \text{ m/s}$$

yields $n = 3.9$

therefore

time spent gathering = .25 (time of cycle)

time spent compacting the spring = .75 (time of cycle)

Substituting $n = 3.9$ into equation (I14) yields a nominal power of

$$P = 98.16 \text{ Watts.}$$

APPENDIX J

Traction Analysis and Blade Selection

This appendix presents a detailed analysis of the traction generated and required by the device. It is based on configuration 1 as presented in the text. A derivation of the optimal depth of dig is presented with respect to energy savings. The force required to make this cut proved greater than the device can generate. To allow an efficient cut, analysis was performed to optimize the blade geometry. Comparing the traction generated with the traction required, a feasible blade geometry was chosen. The scraper blade chosen allows for the regolith to be gathered at a reasonable rate without overcoming the traction generated.

The results of this analysis allows the device essentially no extra traction. In order for the device to climb inclines and handle unexpected terrain, extra traction will be required. The traction analysis performed does not include an allowance for the tread pattern of the wheel. A high traction tread pattern can be used to provide enough extra traction to handle inclines and unexpected terrain.

Assumptions:

- 1) The scraper behaves similarly to a large earth moving scraper.
- 2.) The device load is evenly distributed between the wheels.
- 3.) The device is moving along level ground.

Nomenclature:

α_c = cutting angle

B = blade width

γ = Specific weight of the unbroken structure (N/m^3)

C = cohesion

γ_1 = Specific weight of the broken structure

H = bucket height

$k_4 = (\tan \alpha_c + \tan \phi) / (\tan \alpha_c \tan \phi)$

$\phi = \pi/4 - \rho/2$

ρ = internal angle of friction

$k_f = 1 + k_4 (h/B)$

S = angle of friction for scraper plate

D = wheel diameter

b_w = wheel width

M = mass of vehicle

R_c = resistance to rolling

n = soil deformation factor

k_c = coefficient of cohesive deformation modulus (N/m^2)

k_ϕ = coefficient of frictional deformation modulus (N/m^3)

g = gravity

h = height of dig

P_d = cutting force

P_d = Cutting force

H = generated traction

C_b = soil coefficient of friction (Trafficability)

R = wheel radius

L = chord length

θ = angle that depends on the contact area of the wheel.

Methodology:

Determine the net traction generated by the device. Using the available parameters, determine cutting blade geometry to reduce cutting force. The critical issue is that the cutting force needs to be less than the traction

Analysis:

$$H = AC_b + Mg \tan \phi - Rc \quad [J1] \quad (J1)$$

$$A = bL = bR^2 \theta \quad [J2] \quad (J2)$$

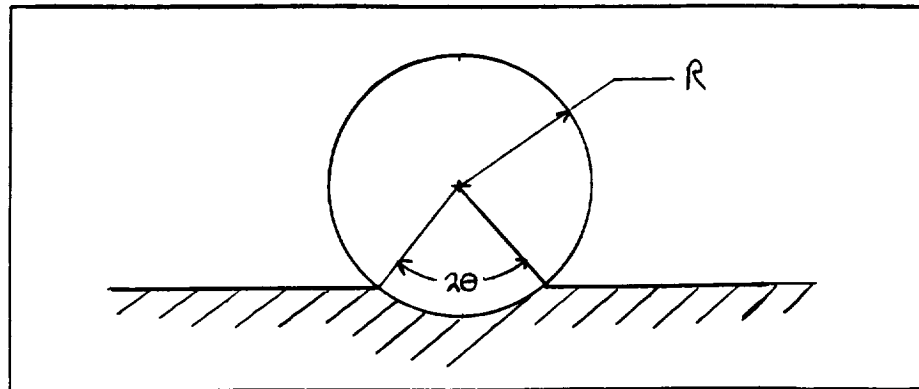

Figure J1. Description of equation (J2)

$$\theta \left(\frac{\sin \theta}{\theta} - \cos \theta \right) = \frac{Mg}{2bR^2(k_c/b + k_\phi)} \quad [J3] \quad (J3)$$

Note: a numerical solution must be used to solve for θ

$$R_c = \frac{\left(\frac{3Mg}{\sqrt{2R}} \right)^{\left(\frac{2n+2}{2n+1} \right)}}{(3-n)^{\left(\frac{2n+2}{2n+1} \right)} (n+1)(k_c + bk_\phi)^{\left(\frac{1}{2n+1} \right)}} \quad [J4] \quad (J4)$$

Conclusion:

Using a spreadsheet to solve for θ in equation (J3) plots were made of traction vs wheel width, traction vs mass and traction vs wheel radius. This was done to determine at which point changing these parameters had little effect on the generated traction. The traction advantage gained begin to decrease in small amounts after $b_w >$ about .15m. Therefore the wheel width chosen is 15cm. As shown in Figure J4, traction proved to be linear with mass over the range investigated. Because of other limitations, mass will not be arbitrarily increased to increase traction. An investigation of Figure J3 shows that the advantage gained by increasing the wheel radius begins to taper off at about $R = .40m$. The wheel radius is chosen to be 40cm. Values used to perform this analysis are.

$$M = 1500 \text{ kg}$$

$$g = 1.624 \text{ m/s}^2$$

$$b = .15 \text{ m}$$

$$R = .5m$$

$$k_c = 1400 \text{ N/m}^2$$

$$k_\phi = 820000 \text{ N/m}^2$$

$$n = 1$$

$$\phi = -.61 \text{ rad}$$

$$C_b = 170 \text{ N/m}^2$$

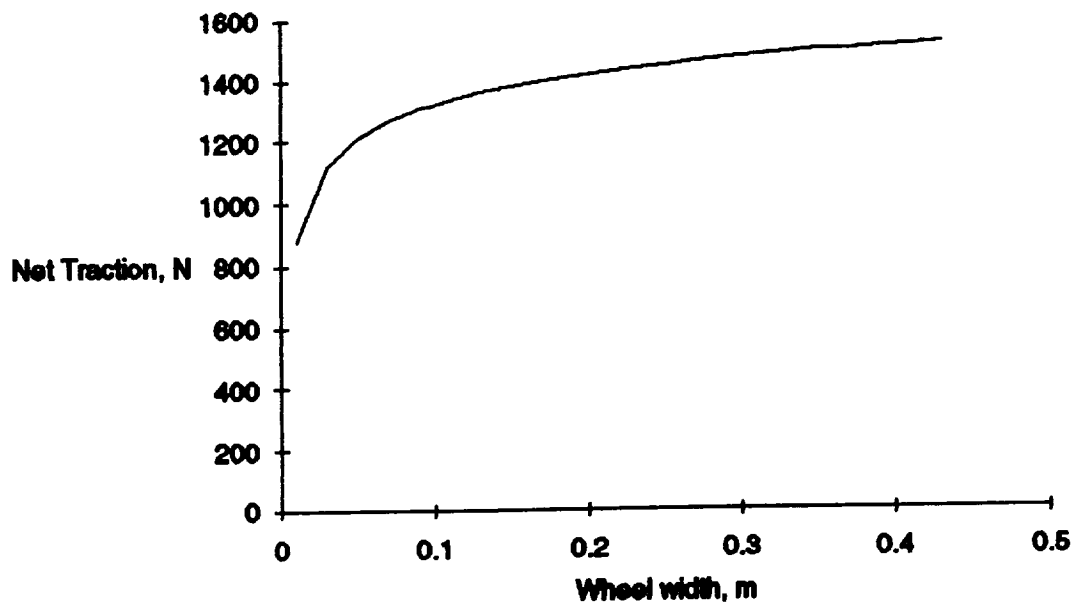

Figure J2. Net traction as function of wheel width.

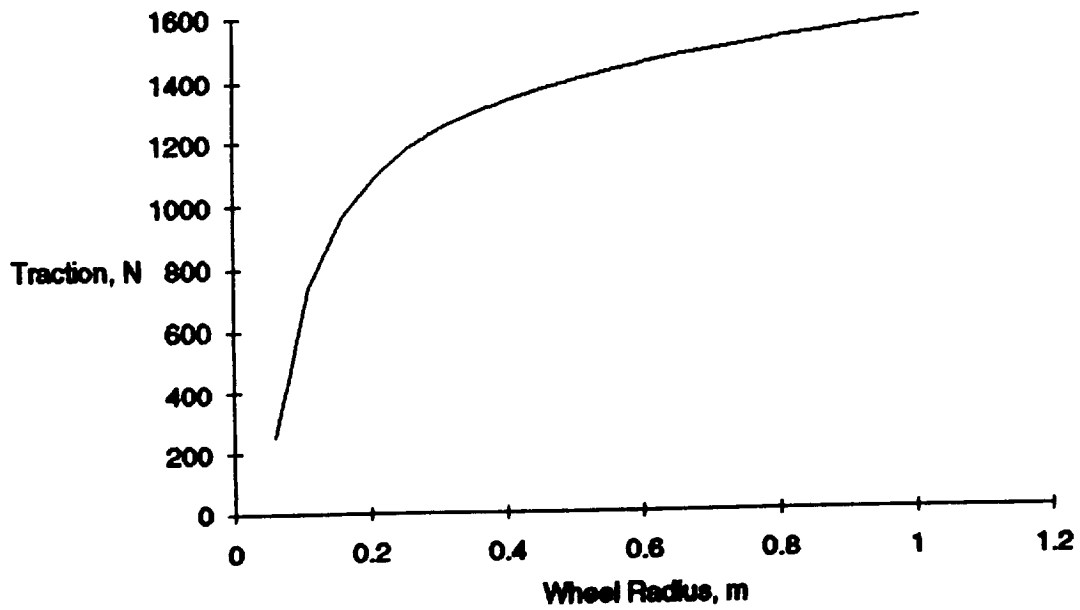

Figure J3. Traction as a function of wheel radius.

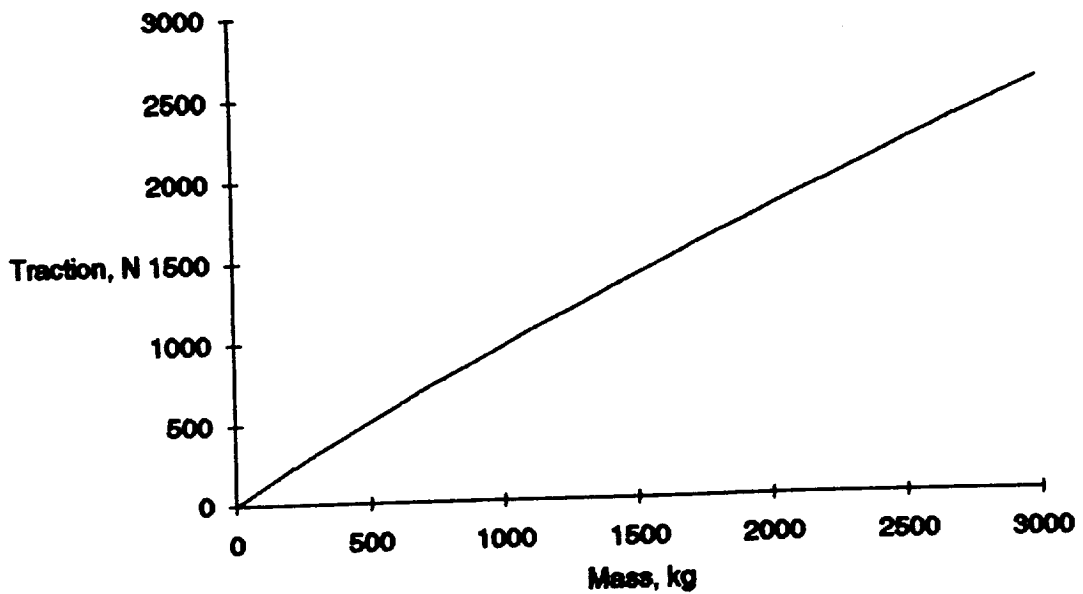

Figure J4. Traction as a function of device mass.

Cutting Force

Analysis:

The cutting force, P_d , can be expressed as,

$$P_d = Q_1 h (Q_2 h + (1 + Q_3 h) Q_4 / h + Q_5) \quad [J5] \quad (J5)$$

Where

$$Q_1 = (1 + \cot \alpha_c \tan \delta) A_1 B \quad (J6)$$

$$Q_2 = \gamma / 2 \quad (J7)$$

$$Q_3 = k_4 / B \quad (J8)$$

$$Q_4 = (\gamma_1 \cos^2 \rho \tan \phi H^2) / k_4 \quad (J9)$$

$$Q_5 = \gamma_1 H + c \cot \rho \quad (J10)$$

and

$$A_1 = (1 - \sin \rho \cos 2\alpha_c) / (1 - \sin \rho) \quad (J11)$$

The total work of gathering is the work to gather added to the work to roll around. The following analysis minimizes the work required given that a required volume of regolith needs to be gathered from a specified area.

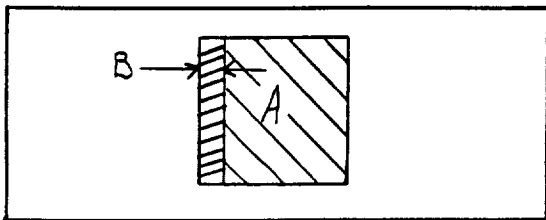

Figure J5. Width of cut, B , on Area, A .

$$W_{total} = FD = (Pd + R_c)D \quad (J12)$$

From geometrical properties

$$\text{Volume gathered} = A \cdot h \quad (J13)$$

$$B \cdot D = A \quad (J14)$$

Substitute (J13) into (J14) and rearrange for D gives

$$D = \text{Volume} / Bh \quad (J15)$$

Substitute into (J12) yields

$$W_{total} = \frac{(Pd + R)}{Bh} \quad (J16)$$

Substituting (J5) into (J16) yields

$$W = \left(\frac{\#}{B}\right) h^{-1} \left[Q_1 h (Q_2 h + \frac{(1 + Q_3 h) Q_4}{h} + Q_5) + R \right] \quad (J17)$$

$$\frac{dW}{dh} = \frac{\#}{B} \left[Q_1 Q_2 - \frac{(Q_1 Q_4 + R)}{h^2} \right] = 0 \quad (J18)$$

solving for h yields

$$h = \sqrt{\frac{Q_1 Q_4 + R}{Q_1 Q_2}} \quad (J19)$$

Conclusions:

Using values of $\alpha_c = .44 \text{ rad}$, $B = .4 \text{ m}$, $\gamma = 2351 \text{ N/m}^2$, $c = 520 \text{ N/m}^2$, $\gamma_1 = 1763 \text{ N/m}^2$, $H = .6 \text{ m}$, $\rho = .61 \text{ rad}$, $\delta = .44 \text{ rad}$, $D = .75 \text{ m}$, $b_w = .15 \text{ m}$, $M = 1500 \text{ kg}$, $n = 1$, $k_c = 1400 \text{ N/m}^2$, $k_p = 820000 \text{ N/m}^2$ and $g = 1.624 \text{ m/s}^2$ gives an optimal value for h of $.6 \text{ m}$. The cutting force required to make this depth of cut is over 4000 N . This cutting force is unacceptable as it exceeds the traction by an order of magnitude. Therefore, it was necessary to construct the blade geometry to minimize the cutting force. Using the above values as the nominal values, graphs of cutting force vs various geometrical properties were generated to investigate the effect each parameter had on the cutting force P_d .

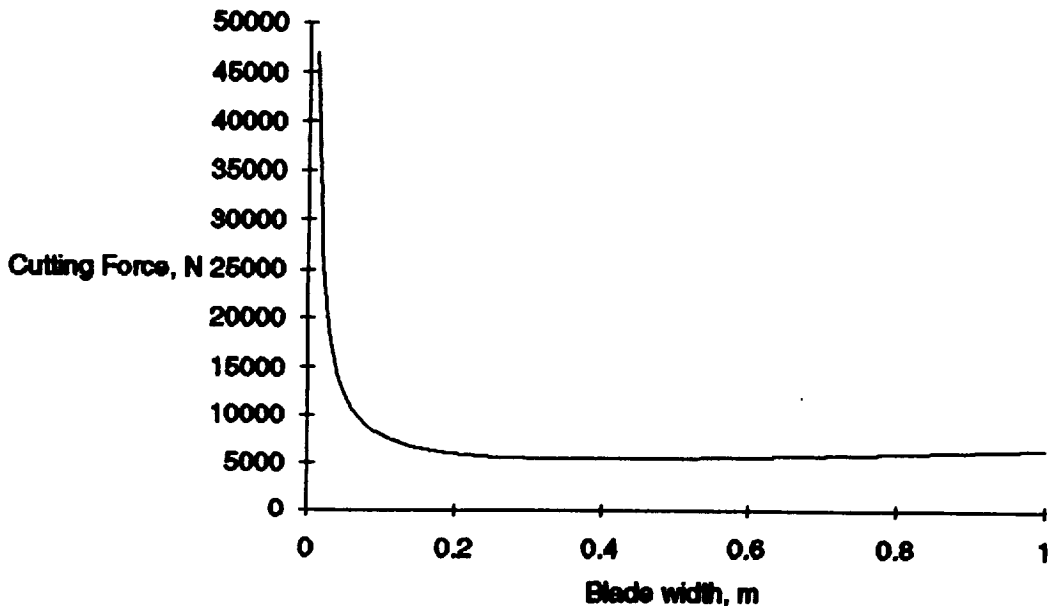

Figure J6. Cutting force as a function of blade width.

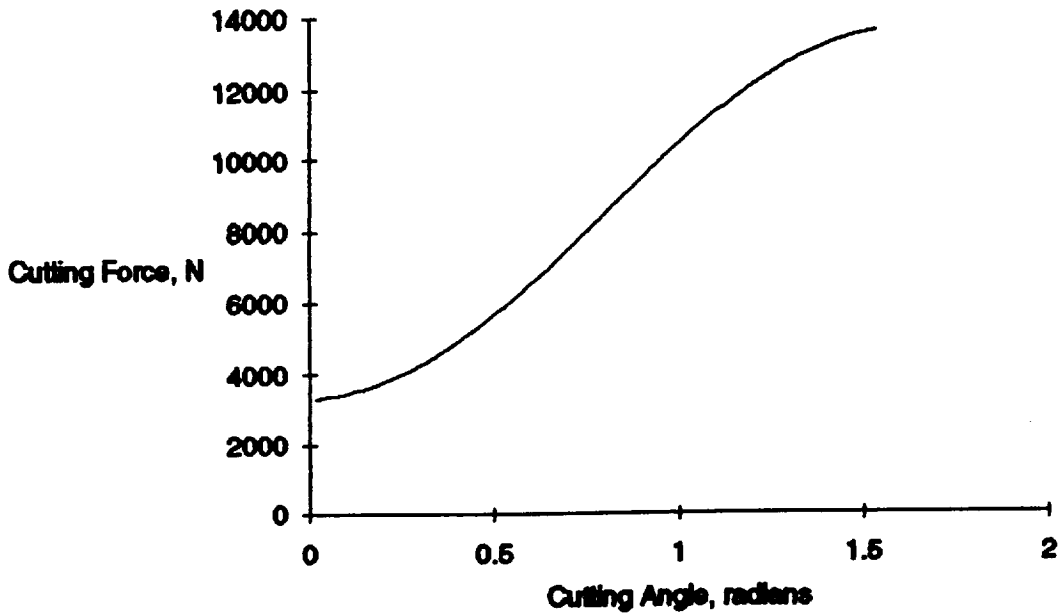

Figure J7. Cutting force as a function of cutting angle.

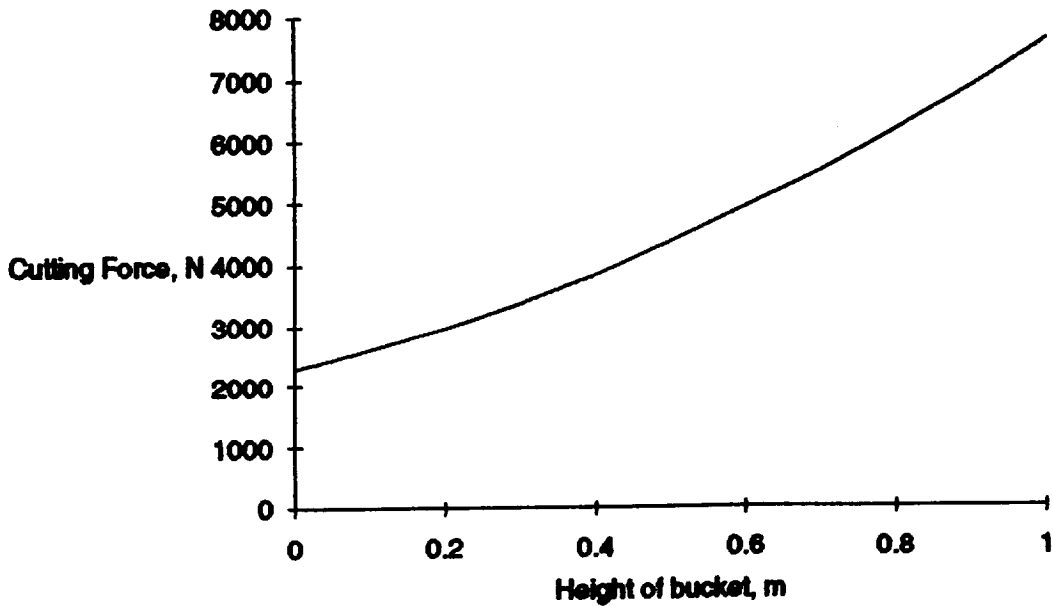

Figure J8. Cutting force as a function of bucket height.

Using Figure J7, Figure J8 and Figure J9 as guides, the blade geometry was chosen as follows.

$$B = .4\text{m}$$

$$H = .6\text{m}$$

$$\alpha_c = 25^\circ$$

Shown below is a new plot of cutting force as a function of the depth of dig.

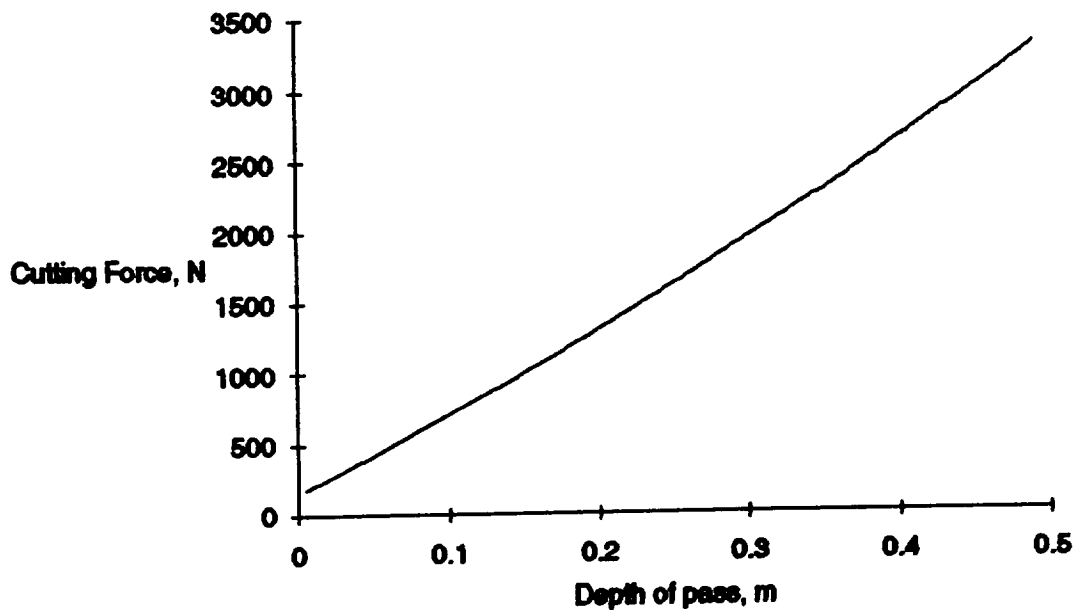

Figure J9. Cutting force versus depth of cut

Choosing a depth of pass, h , of about 5cm gives a cutting force, P_d , of 400N. The device, depending on its mass, will generate approximately 400N of traction. This prevents the device from overcoming inclines and obstacles. The traction equation does not take into consideration the tread of the wheels. It is believed that a high traction tread pattern will prevent any loss of traction.

REFERENCES

- J1. Banks, J., Efatpenah, K., Sines J. L., "Conceptual Design and Analysis of Road Construction Machinery for Initial Lunar Base Operations," (University of Texas as Austin: Austin, TX, 1990), p. C2.
- J2. Banks, J., Efatpenah, K., Sines J. L., "Conceptual Design and Analysis of Road Construction Machinery for Initial Lunar Base Operations," (University of Texas as Austin: Austin, TX, 1990), p. C6.
- J3. Banks, J., Efatpenah, K., Sines J. L., "Conceptual Design and Analysis of Road Construction Machinery for Initial Lunar Base Operations," (University of Texas as Austin: Austin, TX, 1990), p. C7.
- J4. Bekker, M.G., Off Road Locomotion, (The University of Michigan Press: Ann Arbor, MI, 1960), p. 28.
- J5. Balovnev, V. I., New Methods for Calculating Resistance to Cutting of Soil, (Rusvuzizdat Publishers, 1963), p. 75.

APPENDIX K

Determination of Launch Load Size and Device Velocity

The determination of a launch load size and a velocity of the lunar device are addressed in this appendix. A plot of the volumetric collection rate of regolith for each device was plotted against the side dimension of a launch volume of regolith. A cube of regolith was assumed as the launch mass. The practical lower limit was seen as a cube of regolith 0.2 m on a side. Larger sizes create geometrical and technical problems.

By assuming a bulldozer modification, or ramp, for regolith collection a necessary device velocity was calculated. A necessary velocity is that velocity which assures the collection of enough regolith to cover the habitat in one lunar day. A volume of collected regolith was approximated by a box. By setting this volume equal to the known volumetric rate, determined in the first part of this appendix, the device velocity was then calculated. The velocity of the device must be approximately 0.187 km/hr (0.116 mph). This extremely low velocity is desirable, as it is easier and safer if the lunar device travels slowly.

DETERMINATION OF LAUNCH LOAD
SIZE AND LUNAR DEVICE VELOCITY

% OF CYCLE TIME COLLECTING REGOLITH
= 25%

% OF CYCLE TIME ENERGIZING SPRING
AND THROWING REGOLITH = 75%
[THESE NUMBERS DERIVED IN
APPENDIX (I)]

1 CYCLE \equiv PERIOD TO COLLECT ONE
LAUNCH LOAD, COMPRESS SPRING,
AND THROW LOAD

NEED TO COLLECT 314.2 m^3 OF REGOLITH
IN $\frac{1}{4}$ LUNAR DAY (PER UNIT).
[ASSUMES 10 UNITS].

NUMBER OF CYCLES (= NUMBER OF THROWS)
{PER DEVICE}
 $= 314.2 / \text{VOL. OF LAUNCH LOAD}$

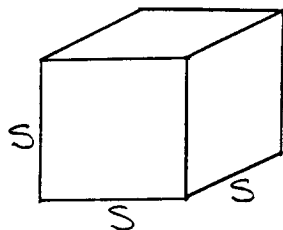

VOLUME OF
LAUNCH LOAD
 $= S^3$
 $= V_{\text{LAUNCH}}$

NUMBER OF CYCLES / SECOND

$$= \frac{314.2}{V_{\text{LAUNCH}}} \cdot \frac{1}{T_{\text{JOB}}}$$

$$T_{\text{JOB}} = 1 \text{ LUNAR DAY} \\ = 14 \text{ EARTH DAYS}$$

TIME / CYCLE

$$= \frac{T_{\text{JOB}} \cdot V_{\text{LAUNCH}}}{314.2}$$

(K1)

Time/Cycle vs. Launch Vol. Side Dim.

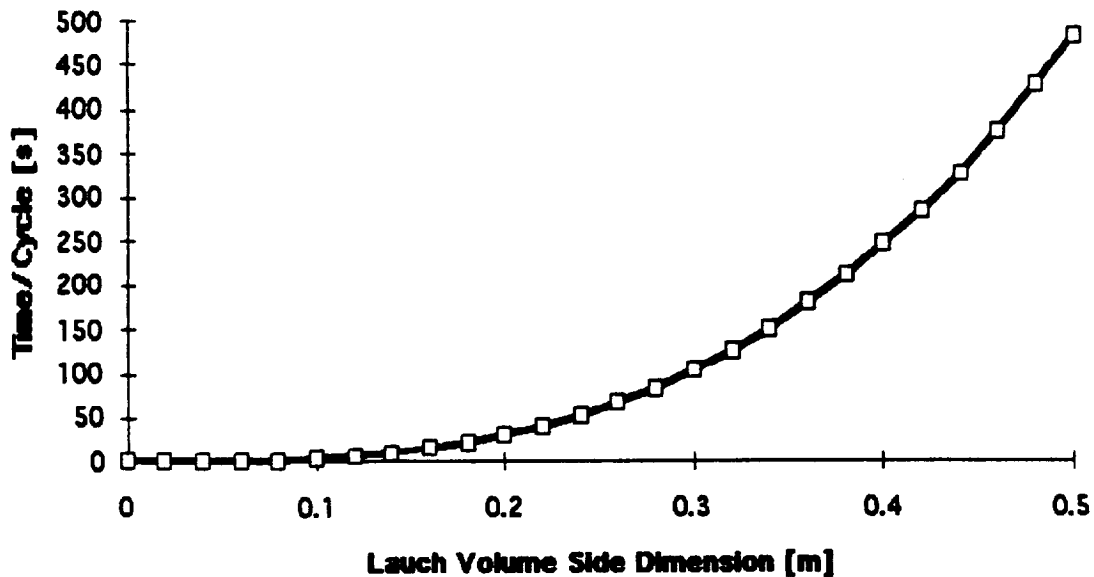

PLOT OF EQUATION (K1).

0.2 m x 0.2 m x 0.2 m LAUNCH LOAD

- LOWER LIMIT WITH RESPECT TO
TIME PER CYCLE

- BIGGER LOADS CAUSE GEOMETRICAL
AND TECHNICAL PROBLEMS (DUE
TO LARGE SIZE AND MASS)

FOR LAUNCH LOAD OF $0.2 \times 0.2 \times 0.2 \text{ m}^3$
TIME/CYCLE = 30.79 SECONDS

IF DEVICE USES BULLDOZER MODIFICATION (i.e. RAMP) TO COLLECT REGOLITH, THEN VEHICLE SPEED CAN BE DETERMINED. THERE IS A MINIMUM VOLUMETRIC RATE OF REGOLITH COLLECTION TO BE MET. THE DEVICE MUST MOVE FAST ENOUGH TO MEET THIS.

$$\dot{V}_{\text{DEVICE}} = \frac{\dot{V}_{\text{JOB}}}{X \cdot \left(\frac{25}{100} T_{\text{JOB}} \right)}$$

$$\begin{aligned} \dot{V}_{\text{JOB}} &= \text{VOLUME OF REGOLITH NEEDED TO COVER HABITAT.} \\ &= 3142 \text{ m}^3 \end{aligned}$$

$$\begin{aligned} X &= \text{NUMBER OF DEVICES} \\ &= 10 \text{ (SEE APPENDIX H)} \end{aligned}$$

$$\begin{aligned} T_{\text{JOB}} &= \text{TIME TO COMPLETE COVERAGE} \\ &= 1 \text{ LUNAR DAY} \end{aligned}$$

$$\dot{V}_{\text{DEVICE}} = 1.039 \times 10^{-3} \text{ m}^3/\text{s}$$

THIS IS THE VOLUME OF REGOLITH EACH DEVICE MUST COLLECT PER SECOND.

- APPROXIMATE REGOLITH VOLUME COLLECTED AS BOX...

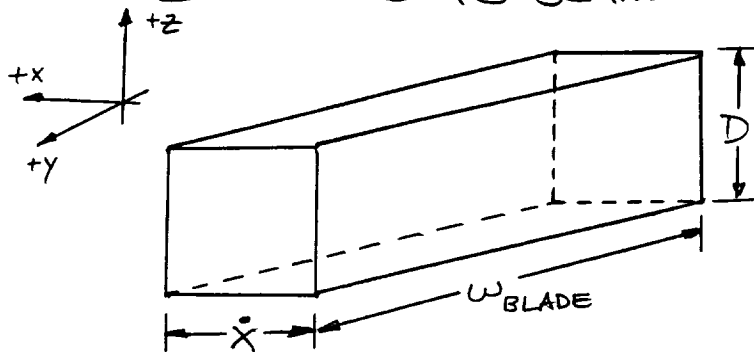

\dot{x} ~ DEVICE'S FORWARD VELOCITY

w_{BLADE} ~ WIDTH OF BLADE

$$= 0.4 \text{ m}$$

D = DEPTH OF DIG (PER PASS)

$$= 0.05 \text{ m}$$

(SEE APPENDIX
NUMBERS)

FOR THESE

$$\dot{V}_{\text{DEVICE}} = \dot{x} \cdot w_{\text{BLADE}} \cdot D = 1.039 \times 10^{-3} \text{ m}^3/\text{s}$$

$$\begin{aligned} \therefore \dot{x} &= 0.052 \text{ m/s} \\ &= 0.187 \text{ km/hr} \\ &= \underline{\underline{0.116 \text{ mph}}} \end{aligned}$$

THIS IS A VERY SLOW VELOCITY, WHICH IS DESIRABLE. IT IS BOTH EASIER AND SAFER IF THE LUNAR DEVICE TRAVELS THE LUNAR SURFACE SLOWLY.

APPENDIX L

Dimensioned Sketch of Lunar Device

This appendix presents the analysis done to generate a dimensioned sketch of configuration #1, which is the configuration to be computer simulated. The basis for the dimensions was the RTG power source. The size of the RTG was determined from the power requirements of the lunar device. Additionally, the blade requirements were known beforehand. The lunar device was then scaled from these known dimensions.

The results are a device 0.4 m tall with 0.2 m ground clearance. The width of the device is 0.66 m. The length of the body of the device is 1.0 m. The overall length of the device, including the blade, is approximately 2.8 meters. The estimated mass of the lunar device is 150 kg.

DIMENSIONED CONFIGURATION OF SYSTEM
FOR COMPUTER SIMULATION

FROM APPENDIX J :

40 cm WIDE BLADE

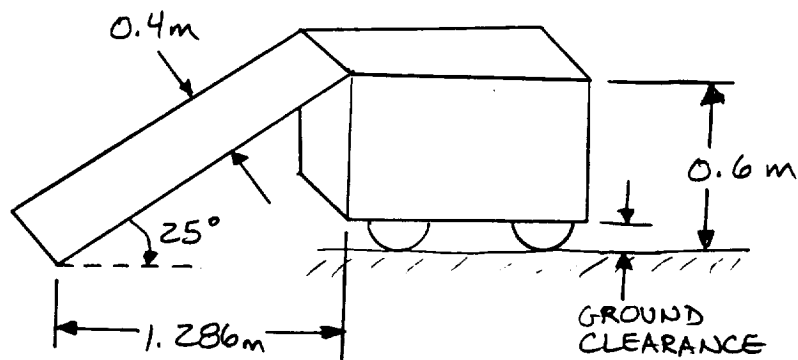

100 W AVERAGE POWER TO
ROLL, GATHER, AND THROW.

USE RTG TO POWER DEVICE...
DOUBLE POWER REQUIREMENT FOR
PEAK POWER, ELECTRICAL SYSTEMS,
SAFETY FACTOR.

MOD-RTG : 1 MODULE : 19 W_e
9.7 cm x 9.4 cm x 5.3 cm
2.262 kg

18 MODULE UNIT : 342 W_e
41.1 kg
0.09237 m³ VOLUME

- 90.6% VOLUME NOT MODULES
(FINS, CONVERSION SYSTEMS, ETC.)
- 0.93% MASS NOT MODULES

SCALE NEEDED RTG FROM THESE NUMBERS.
-200 W_e RTG SYSTEM NEEDED

11 MODULES : 209 W_e
24.882 kg
5.3158 x 10⁻³ m³ } MODULES MASS, VOL.

$$\text{TOTAL MASS: } \frac{41.1}{18} \times 11 = \underline{\underline{25.117 \text{ kg}}}$$

$$\text{TOTAL VOLUME: } \frac{0.09237}{18} \times 11 = \underline{\underline{0.05645 \text{ m}^3}}$$

N.B. : ASSUMES MASS AND VOLUME VARY
LINEARLY FOR RTGs.

* 342 W_e RTG : CYLINDRICAL
0.33 m IN DIAMETER

IF OUR RTG NEEDS TO BE CYLINDRICAL:

$$\frac{\pi}{4} d^2 l = 0.05645 \text{ m}^3 \text{ WHERE } d = 0.33 \text{ m}$$

$$\therefore l = 0.66 \text{ m}$$

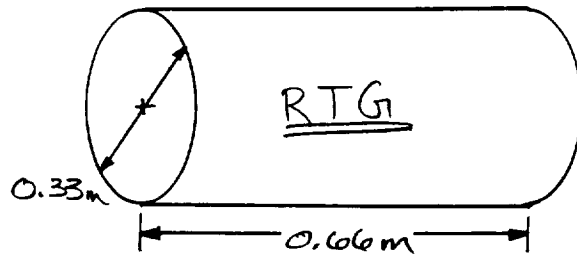

$$m = 25.117 \text{ kg}$$

$$V = 0.05645 \text{ m}^3$$

- ASSUME GROUND CLEARANCE OF 0.2 m
- MOUNT RTG SO LONG AXIS IS \perp TO DIRECTION OF MOTION.
- PLACE RTG NEAR BACK TO BALANCE WEIGHT OF RAMP.

NAVIGATIONAL UNIT (EXAMPLE)

HONEYWELL; LIGHTWEIGHT INERTIAL
MEASUREMENT UNIT (LIMU)

POWER $< 11 \text{ W}$

MASS $< 0.35 \text{ kg}$

VOLUME $\approx 434 \text{ cm}^3$

[FROM SALES BROCHURE]

- THESE LOW NUMBERS INDICATE THAT INCORPORATING A LIMU SYSTEM INTO LUNAR DEVICE WILL NOT CREATE ANY MAJOR POWER OR VOLUME PROBLEMS.

MASS OF RAMP:

ASSUME -Ti ($\rho = 4500 \text{ kg/m}^3$)

- THICKNESS = 0.01 m

- WIDTH = 0.4 m

LENGTH, l

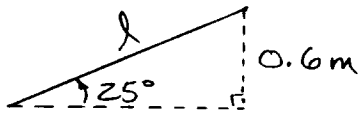

$$\sin 25^\circ = \frac{0.6}{l} \quad \therefore l = 1.419 \text{ m}$$

ADD 0.4 m FOR OVERHANG OVER DEVICE,

$$l_{\text{BLADE}} = 1.82 \text{ m}$$

$$\begin{aligned} m_{\text{BLADE}} &= (0.01)(1.82)(0.4)(4500) \\ &= \underline{\underline{32.76 \text{ kg}}} \end{aligned}$$

BASE SCALING OF SKETCH
OFF OF DIMENSIONS
OF RTG, SHOWN EARLIER.

DEVICE MUST :

- BE AT LEAST AS WIDE AS RTG IS LONG
= 0.66 m [SEE PREVIOUS PAGE]
- HAVE TOP AT LEAST 0.6 m OFF GROUND
→ SPECIFIED BY RAMP
- HAVE 0.2 m GROUND CLEARANCE;
ASSUMED, BASED ON DATA ON LUNAR
SURFACE.

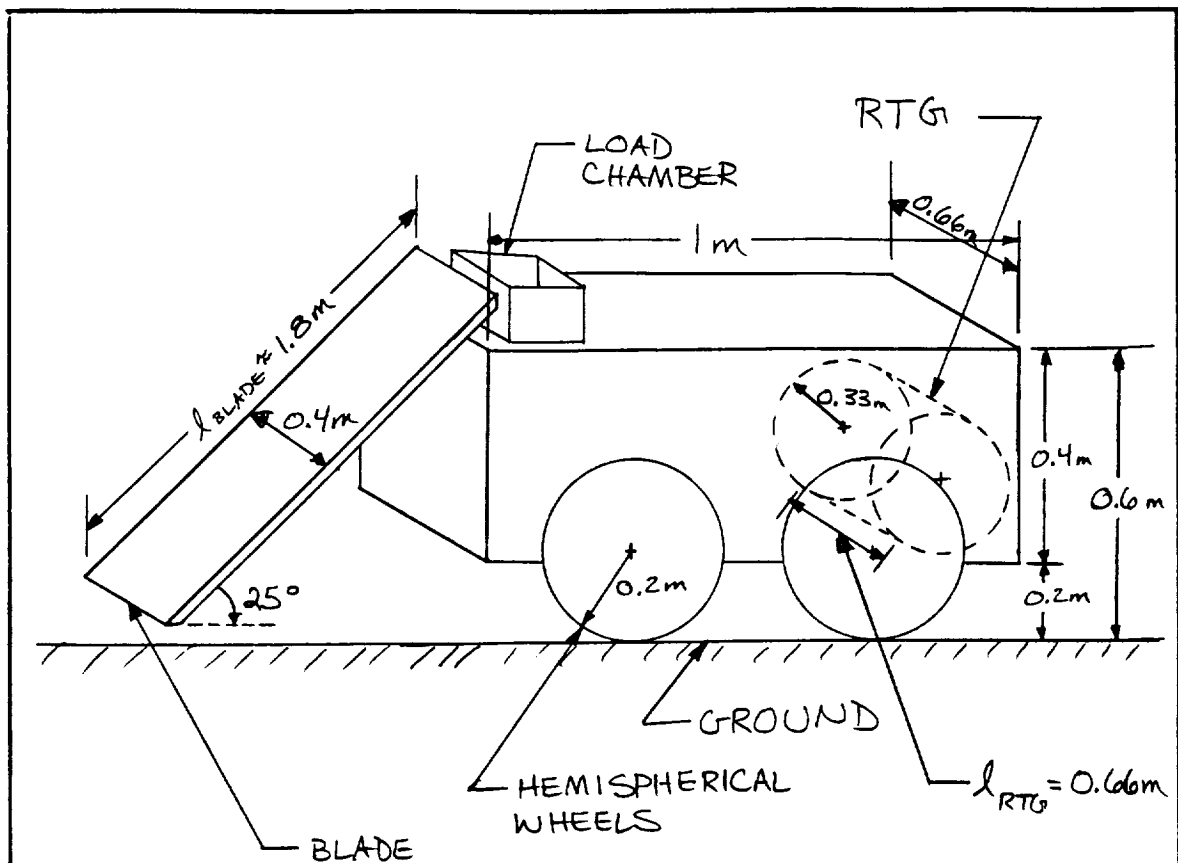

MASS ESTIMATE:

INS / SENSORS ≈ 20
 BLADE / RAMP $\approx 33 \text{ kg}$
 RTG $\approx +25 \text{ kg}$
 $= 75 \text{ kg}$

MULTIPLY BY TWO TO ACCOUNT FOR
 DRIVE TRAIN SYSTEM, WHEELS, FRAMEWORK,
 ETC.

MASS OF DEVICE $\approx \underline{\underline{150 \text{ kg}}}$ [ESTIMATED]

EARLIER, BLADE OVERHANG MENTIONED.
 QUANTIFICATION:

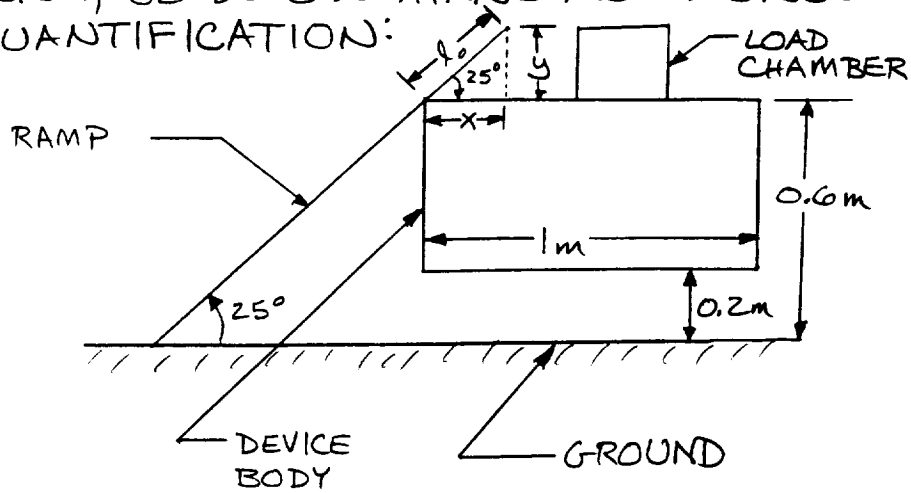

SIDE VIEW

$l_0 \sim$ LENGTH OF OVERHANG

y MUST BE HEIGHT OF LOAD CHAMBER AT MINIMUM

$$l_0 = \frac{y}{\sin 25^\circ} \quad x = \frac{y}{\tan 25^\circ}$$

$y(m)$	$x(m)$	$l_0(m)$
0.1	0.22	0.24
0.2	0.425	0.47
0.3	0.64	0.71

$y=0.3m$ WILL PROBABLY NOT WORK. LOAD CHAMBER HAS TO BE TOWARDS BACK OF DEVICE FOR FILLING. ALSO, 0.71m OVERHANG MAY INTERFERE WITH THROWING.

APPENDIX M

Instability of Lunar Device Upon Release of Regolith Load

This appendix addresses the tendency for the lunar device to tip when a regolith load is launched. When a load of regolith is launched from the lunar device, an acceleration is imparted to the device. This acceleration was modeled as a force input to the lunar device system. The force is equal to the launch mass times the acceleration. The highest acceleration is just after the load of regolith is released. If the lunar device tips when throwing regolith, the accuracy of a throw will be adversely affected.

Results show that there is indeed a problem with the lunar device tipping on the release of a load of regolith. A minimum device mass of 3755 kg is needed to prevent the lunar device from moving upon regolith launch. The estimated system mass is 150 kg. This difference means the lunar device will move when a load is launched. More analysis needs to be done to determine whether the lunar device actually flips over or rocks back and forth. Either of these results will have negative effects on the performance of the lunar device. Additionally, more design work is needed to remove the tipping problem.

INSTABILITY IMPARTED TO LUNAR DEVICE BY THROWING MOTION

ASSUME: 4-WHEELED VEHICLE

MASS_{THROWING MECHANISM} < MASS_{LUNAR DEVICE}

TWO EXTREME CASES FOR THROWING:
THROWING IN X-DIRECTION AND
THROWING IN Y-DIRECTION.

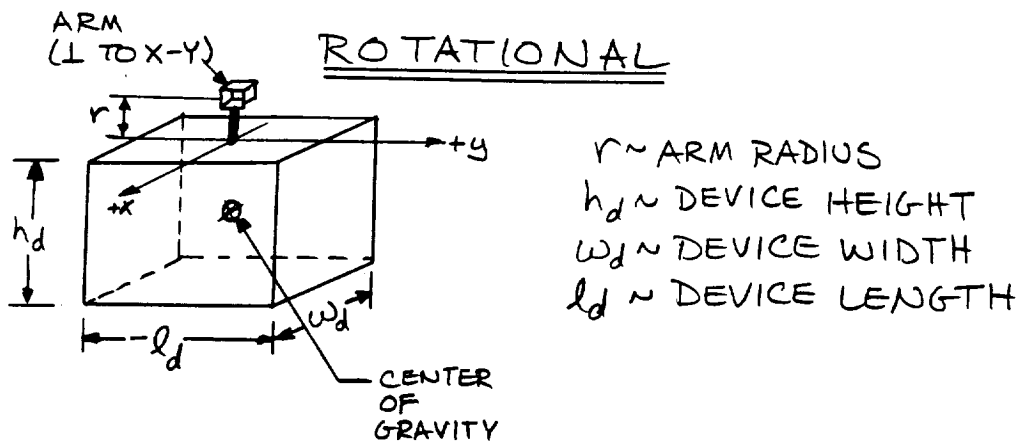

N.B.: ASSUMES CENTER OF GRAVITY IN MIDDLE OF BODY. FAIR APPROXIMATION.

APPROXIMATE REACTION FORCE ON BODY AS
MASS OF LOAD X ACCELERATION OF MASS.

FBD

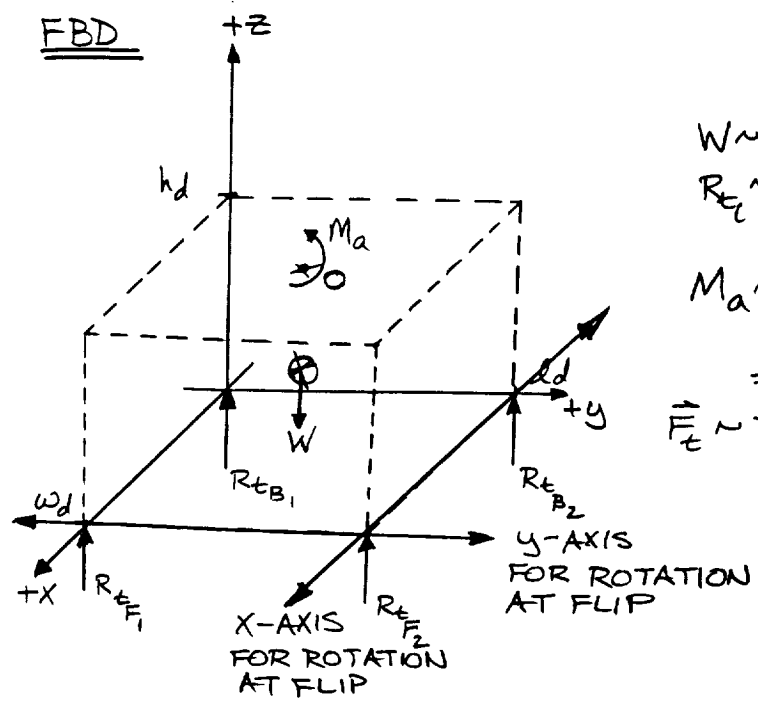

$W \sim$ DEVICE WEIGHT
 $R_{t_i} \sim$ TIRE RESULTANT FORCE
 $M_a \sim$ MOMENT FROM THROWING-ARM.
 $= \vec{F}_t \times \vec{r}$
 $\vec{F}_t \sim$ THROWING FORCE.

2) ROTATION ABOUT y-AXIS; THROWING IN +x DIRECTION

AT INSTANCE OF FLIP: $R_{tB_i} = 0$

$$\vec{M}_a = \vec{r} \times \vec{F}_t = r \hat{k} \times F_t \hat{z} = F_t r \hat{j}$$

$$\Sigma F_z = 0 = 2 R_{tF} = W$$

* \vec{M}_a MUST OVERCOME MOMENT DUE TO W FOR FLIPPING.

$$\vec{M}_a \geq -\vec{M}_W = +\frac{1}{2} \omega_d \hat{z} \times W \hat{k} = +\frac{1}{2} \omega_d W \hat{j}$$

$$\therefore \underline{\underline{F_t r \geq \frac{1}{2} \omega_d W}} \text{ FOR FLIP.}$$

ii) ROTATION ABOUT X-AXIS; THROWING IN +y DIRECTION.

N.B. ASSUME WHEELS LOCKED (i.e. BRAKES ENGAGED)

AT INSTANCE OF FLIP: $R_{t_{F_1}} = R_{t_{B_1}} = 0$

$$\therefore R_{t_{F_2}} = R_{t_{B_2}} = \frac{1}{2} W$$

$$\vec{M}_a \geq +\vec{M}_w \quad : \quad \vec{M}_a = \vec{r} \times \vec{F} = r \hat{k} \times F \hat{j} = -r F \hat{i}$$

$$\begin{aligned} \vec{M}_w &= \vec{r} \times \vec{F} = -\frac{1}{2} l_d \hat{j} \times -W \hat{k} \\ &= \frac{1}{2} l_d W \hat{i} \end{aligned}$$

$$\therefore \underline{\underline{F r \geq \frac{1}{2} l_d W}} \quad \text{FOR FLIP.}$$

LINEAR

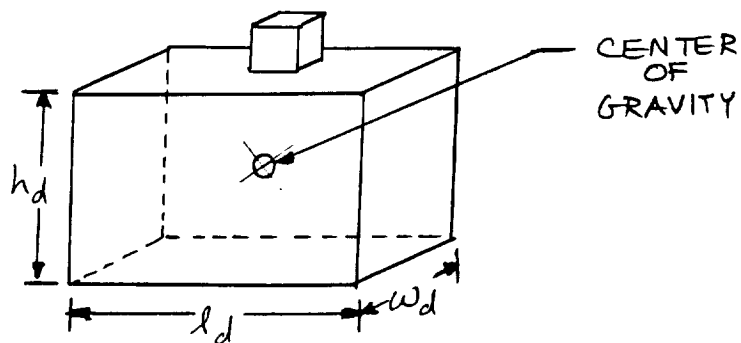

ASSUME: - LAUNCH PAD DOES NOT GO PAST EDGE OF DEVICE.

- WHEELS LOCKED (i.e. BRAKES ENGAGED)
- CENTER OF GRAVITY IN MIDDLE OF BODY.
- APPROXIMATE REACTION FORCE ON BODY AS MASS OF LOAD \times ACCEL. OF MASS

FBD

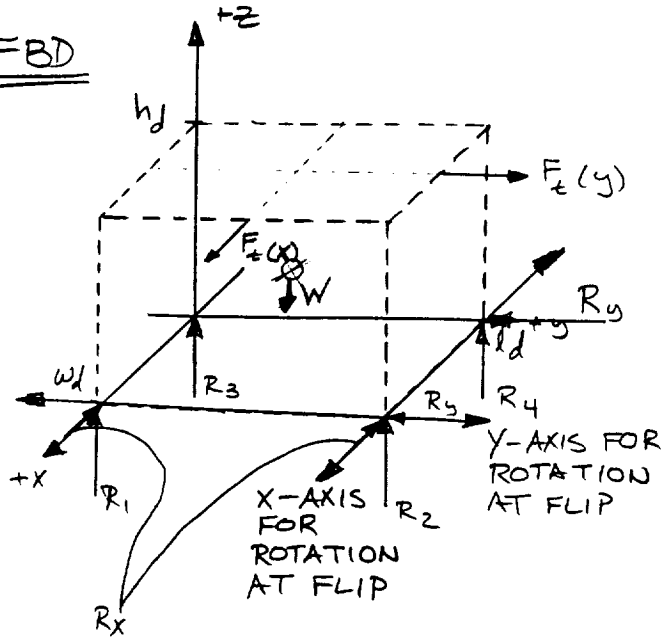

$F_{t(y)}$ ~ FORCE IMPARTED TO LUNAR DEVICE IN 'C' DIRECTION

R_i ~ RESULTANT FORCES AT TIRES

W ~ DEVICE WEIGHT

R_x AND R_y ~ FORCES ACTING AT WHEELS, ON LINE OF TIPPING, TO PREVENT LINEAR ACCELERATION IN FORCE APPLICATION DIRECTION.

2) ROTATION ABOUT X-AXIS; THROWING IN +Y-DIRECTION. → USE $F_{t(y)}$

AT TIPPING: $R_1 = R_3 = 0$
 $R_y = \frac{1}{2} F_{t(y)}$
 $R_2 = R_4 = \frac{1}{2} W$

MOMENTS ABOUT X-AXIS Σ TO 0;
 $\uparrow W (\frac{1}{2} l_d) = F_{t(y)} h_d$

$\therefore \underline{\underline{F_{t(y)} > \frac{1}{2} W \frac{l_d}{h_d}}}$ FOR FLIP.

ii) ROTATION ABOUT Y-AXIS; THROWING IN
+ X-DIRECTION \rightarrow USE $F_{t(x)}$

AT TIPPING: $R_3 = R_4 = 0$
 $R_x = \frac{1}{2} F_{t(x)}$
 $R_1 = R_2 = \frac{1}{2} W$

MOMENTS ABOUT Y-AXIS Σ TO 0;
 $\hookrightarrow F_{t(x)}(h_d) = W_d(\frac{1}{2}w_d)$

$\therefore \underline{\underline{F_{t(x)} > \frac{1}{2} W \left(\frac{w_d}{h_d} \right) \text{ FOR FLIP.}}}$

N.B. IF LINEAR THROWING DEVICE ANGLED,
FORCE ACTING TO FLIP IS REDUCED.

$$F_t' = F_t \cos \theta$$

PART OF FORCE ACTS UP, TRYING TO
LIFT DEVICE OFF OF LUNAR SURFACE.

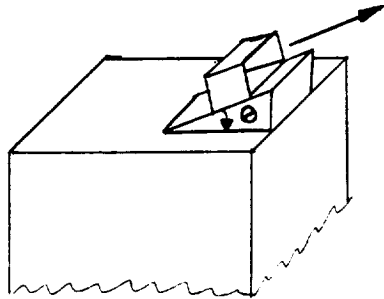

N.B.: DYNAMIC ANALYSIS, ACCOUNTING FOR
INERTIA OF DEVICE NEEDS TO BE
DONE.

CHECK OF TIPPING AS APPLIED TO DEVICE,
USING ABOVE EQUATIONS.

$U_0 = 12 \text{ m/s}$ LAUNCH VELOCITY

$h_d = 0.6 \text{ m}$ HEIGHT OF DEVICE (INCLUDES
GROUND CLEARANCE)

$w_d = 0.66 \text{ m}$ WIDTH OF DEVICE

$$\begin{aligned} F_t &\geq \frac{1}{2} W_{\text{TOTAL}} \frac{w_d}{h_d} \\ &\geq \frac{1}{2} \left(\frac{1}{6} g m_{\text{TOTAL}} \right) \left(\frac{w_d}{h_d} \right) \\ &\geq \frac{g}{12} \left(\frac{0.66}{0.6} \right) m_{\text{TOTAL}} ; \text{ TO TIP} \end{aligned}$$

$$F_t \geq 0.8989 m_{\text{TOTAL}} \quad [\text{N}]$$

APPROXIMATE F_t AS MASS OF LAUNCH
TIMES ACCELERATION...

$$m_{\text{LAUNCH}} = \rho_R (0.2)^3$$

$$\rho_R = 1465 \text{ kg/m}^3$$

LAUNCH VOLUME ASSUMED CUBE

0.2 m ON A SIDE

(SEE APPENDIX K)

$$m_{\text{LAUNCH}} = \underline{\underline{11.72 \text{ kg}}}$$

$$a(t) = x_d \frac{k}{m_L} \cos\left(\sqrt{\frac{k}{m_L}} t\right) \quad \text{ACCELERATION}$$

(SEE APPENDIX)

$a(t) \Rightarrow$ MAXIMUM WHEN $t=0$

IF $k = 6.75 \text{ kN/m}$

$m_L = 11.72 \text{ kg}$

$x_d = 0.5 \text{ m}$

$$a(t=0) = 287.969 \text{ m/s}^2$$

$$\text{NOW: } F_t \geq 0.8989 m_{\text{TOTAL}}$$

$$m_L a \geq 0.8989 m_{\text{TOTAL}}$$

$$m_{\text{TOTAL}} \leq \frac{m_L a}{0.8989} \quad \text{TO TIP}$$

$$\leq \underline{\underline{3754.59 \text{ kg}}}$$

THIS SAYS THAT DEVICE HAS TO BE OVER
3 METRIC TONS NOT TO TIP WHEN
A LOAD IS LAUNCHED !!!

THE DEVICE WILL DEFINITELY HAVE
A TIPPING PROBLEM.

SYSTEM MASS IS ESTIMATED AT
150 kg !!!

ERRATA SHEET

Errata sheet for the report “Conceptual Design of a Fleet of Autonomous Regolith Throwing Devices for Radiation Shielding of Lunar Habitats.”

- 1) Page 3 line 7. “(see figure 1)” should say “(see Figure 1).”
- 2) Page 28 Caption on Figure 12. “Standard Earth-moving equipment” should say “Standard earth-moving equipment.”
- 3) Page 38 line 14. There should be one fewer space between “shortcoming” and “of LOS.”
- 4) Page 42 line 7. There should be one fewer space between “the” and “system.”
- 5) Page 45 line 7. “This” should appear before “method is memory dependent.”
- 6) Page 46 line 9. “may cause the habitat too collapse” should say “may cause the habitat to collapse.”
- 7) Page 75 line 20. “energy stored on them” should say “energy stored in them.”
- 8) Page 87 last line. There should be a period after “(see Appendix L).”
- 9) Page 90 line 6. “An detailed analysis” should say “A detailed analysis.”
- 10) Page 91 line 18. “parameters that needed to be were” should say “parameters that needed to be determined were.”
- 11) Page 98 line 15. There should be a comma after atmosphere.
- 12) Page 99 line 2. “versatility this device” should say “versatility of this device.”