

NASW-4435

IN 37-R
141656
P.110

ME 4182 - Spring 1992

**GROUP #1
BOOM AND CHASSIS**

Members:

- Jason S. Dell**
- T. Bayne Meeks**
- Kelly Merkel**
- Brent Nelson**
- Tom Winchell**

(NASA-CR-192028) [ACTIVITIES OF
THE BOOM AND CHASSIS GROUP]
(Georgia Inst. of Tech.) 116 p

N93-17975

Unclass

G3/37 0141656

TABLE OF CONTENTS

I.	Abstract.....	1
II.	Problem Statement.....	2
III.	End Sections.....	4
	III.1 Introduction.....	4
	III.2 Constraints on Design	4
	III.3 Other Factors.....	4
	III.4 Analysis and Design.....	5
	III.5 ACHIEVEMENTS	6
IV.	V-Clamps.....	9
	IV.1 Introduction.....	9
	IV.2 Constraints on Design.....	10
	IV.3 Other Factors.....	10
	IV.4 Analysis and Design.....	10
	IV.5 ACHIEVEMENTS	13
V.	Center Section.....	7
	V.1 Introduction.....	7
	V.2 Constraints on Design.....	7
	V.3 Other Factors.....	7
	V.4 Analysis and Design.....	8
	V.5 ACHIEVEMENTS	9
VI.	Boom Structures.....	13
	VI.1 Introduction.....	13
	VI.2 Upper Boom Design.....	14
	VI.2.1 Introduction for Upper Boom Design.....	14
	VI.2.2 Constraints on Design.....	14
	VI.2.3 Analysis and Design.....	15
	VI.2.4 Achievements.....	17
	VI.3 Lower Boom Design.....	17
	VI.3.1 Introduction for Lower Boom Design.....	17
	VI.3.2 Constraints on Designs.....	18
	VI.3.3 Analysis and Design.....	18
	VI.3.4 Achievements.....	19
	VI.4 ELBOWS	20
VII.	Material Selection.....	21
VIII.	Weight Analysis.....	22
IX.	Computer Analysis.....	

X. Summary.....	25
X.1 Achievements.....	25
X.2 Suggestions.....	25
XI. Appendices.....	
XI.1 Drawings.....	
XI.2 Hand-Done Calculations.....	
Manufacturers'	
References.....	27
References.....	28
Acknowledgments.....	29

I. ABSTRACT

Group One of the NASA Lunar Enabler Project has designed the primary chassis and boom structures for the lunar vehicle. Both components also feature V-clamps that were adapted to interface connections within the structure. The chassis features a front end, rear end section, middle cross-section and face plate. The rear section contains an extra compartment for the engine, hydraulic pump, fuel bottles and oil reservoir necessary for the wheel drives. Each section consists of tubular Aluminum 6061-T6. The boom features four degrees of freedom system, where the minimum factor of safety of any part is 1.5 (but, normally much higher). It consists of a tapered upper boom, lower boom, and three elbows that complement the articulation joints. Each section of the boom has been constructed from Aluminum 6061-T6. There are four joints and eight V-clamps in the boom assembly. The V-clamps feature support rings that prevent axial rotation. They provide easy adaptability and assembly.

II. PROBLEM STATEMENT:

Group One was assigned to design and optimize the primary chassis and boom structure for use on the lunar enabler vehicle. Working conditions, loading and the accommodation of other components (i.e. the engine) placed several constraints on both the chassis and boom sections.

The chassis design is largely dependent upon the loading conditions placed upon the boom structure. The chassis should support worst-case loading conditions with a minimum factor of safety of 2. Also, the usable area inside the structure must contain the motor components and controls necessary for operation. Therefore, the area inside the chassis should be maximized, and space should be provided in the rear section for the engine and hydraulic pump. The vertical drop of the engine extension (measured from the center of the wheel) should not be more than 18.2" in the worse case position (see Engine Extension Calculations in Hand Calculations section). Also, the engine dimensions require that the length of the engine extension be a minimum of 20" (measured from the center of the wheel to the end of the extension). In addition, weight should be minimized for maximum performance.

The upper boom must sustain a minimum load of 10 lb.. in a variety of boom positions. Loading characteristics will affect the deflection of the boom in any direction. Therefore, the deflected boom must support itself and the load without tipping or buckling. The boom should sustain worst-case loading conditions with a factor of safety between 1.5 and 2. In the optimization procedure, the upper boom weight should be minimized. Therefore, the weight of the upper boom must be less than 83 lb., the value determined in the previous design iteration.

The lower boom must sustain loading on the upper boom in the worst-case conditions. It must also be geometrically consistent with the motor apparatus. Weight should be minimized to reduce the loading effects on the chassis and prevent tipping or buckling of the boom structure.

In addition, the V-clamps used at the wheel and articulation joint interfaces are constrained by geometry and rotation. The clamps must be easily assembled and disassembled and cannot extend beyond the outer diameter of the connecting sections. In addition, the clamps should prevent axial rotation at the interfaces.

III. END SECTION DESIGN

III.1 INTRODUCTION

The end sections are located at the front and rear ends of the vehicle. The front end section will be used to house the controls of the vehicle, and the rear end section (along with the engine extension) will be used to house the engine and hydraulic system. The end sections must interface with the wheel assembly, either the engine module or face plate, and the articulation joint.

III.2 CONSTRAINTS ON DESIGN

- 1.) Tubing used must have an 18" O.D.
- 2.) Must not contain internal structures (skin must support load). The space inside will be used to house controls and engine.
- 3.) Must be able to interface with the wheel assembly, either the engine extension or the face plate, and the articulation joint.
- 4.) The weight of the sections to should be as light as possible.
- 5.) Section that is to house the engine must not contact the ground when in worst position (18.2 " vertical distance from center of wheel diameter).

(See Engine Extension Calculation in Appendix XI.1, Hand-Done Calculations.)

III.3 OTHER FACTORS

- 1.) The end sections to be modular with the middle cross section.
- 2.) The material at stated dimensions should be easily obtainable.

III.4 ANALYSIS AND DESIGN

Material:

The material to be used was previously chosen to be Aluminum 6061-T6. Although, when calculations were performed on the piece, the material characteristics of Aluminum 6061-T0 were used. The reasoning behind the switch was due to the fact that when Aluminum 6061-T6 is welded, it gets annealed and behaves like Aluminum 6061-T0.

Tube Thickness:

Three criteria determined the thickness of the tubing. One, the dimension of the tubing should be a standard thickness that can easily be purchased. Two, the tube must not fail when the vehicle or the boom is in any position. Three, the end sections should not weigh much relative to the overall weight of the engine and control system. The first criterion was used to pick the thickness of 1/8". The computer analysis done on the piece showed that the second criterion was also satisfied (see Analysis section). The total weight of all three chassis sections at 1/8" thick would be 101 lbs. Relative to the overall weight of the engine and control system (over a hundred pounds), the chassis weight is very small. The worst factor of safety found for any chassis section is 21.33 (see computer analysis).

Interfaces:

Each face of the end section will be riveted to male part of the V-clamp (see V-Clamp Design section). Having V-clamp attachments on all faces

enables the end section to be modular with the middle cross section, and allows easy access to components placed inside the structure.

Engine Extension:

The engine housing extension will not contact the ground at the worst case position. The extension is allowed to hang down 18.2" from the center of the wheel. This distance was determined by the amount the articulation joints will hang down when in the bent position. The calculations showed that the extension could be 20" long from center of the wheel to the end and still meet the clearance criterion. The 12" diameter cylinder that crosses the extension will be used to house the needed propane tanks.

Manufacture:

As stated before, the material to be used for the manufacture of the end sections is Aluminum 6061 - T6. The end sections will be manufactured on site with 1/8" sheets of Aluminum.

III.5 ACHIEVEMENTS

1. Bulkheads (from last quarter) were removed.
2. End section designed to be modular.
3. Tube thickness determined to be 1/8".
4. Interfaces were designed.
5. Engine extension designed.

IV. CENTER SECTION

IV.1 INTRODUCTION

The center section is located between the front and rear articulation joints. It must interface with both of these joints, two wheel assemblies, and the boom. These interfaces consist of two mating rings and a v-clamp. The center section must contain one v-clamp supporting ring for each interface.

IV.2 CONSTRAINTS ON DESIGN

- 1.) Chassis tubing must have an 18" O.D.
- 2.) Chassis sections must not include internal load carrying structures (the skin must sustain all loads)
- 3.) Must be able to interface with wheel assembly, articulation joint, and boom
- 4.) The weight of the structure should be minimized
- 5.) The structure must be able to support worst case loading conditions

IV.3 OTHER FACTORS

- 1.) The center section should be modular with the end sections
- 2.) The materials specified should be easily obtainable in the specified dimensions and must be weldable

IV.4 ANALYSIS AND DESIGN

Material:

The material selected for the center section is aluminum 6061 T-6. This material is easily obtained and is weldable. This means that all components of the center section can be fabricated on location. For calculations, the properties for aluminum 6061 T-0 were used to reflected the annealing which will occur during welding.

Tube Thickness:

The tube thickness was selected on the basis of three criteria. These were availability at that thickness, stresses in worst case loading conditions, and the weight of the section when constructed from the thickness. A thickness of 1/8" was selected. This thickness is widely available. Computer analysis of the stresses show that it will provide a minimum factor of safety of 25. The center section when constructed at this thickness weighs 28 pounds. This weight is small compared to the weight of the boom, wheels, and articulation joints.

Interfaces:

At each face of the center section, there will be a male v-clamp support ring. The v-clamp interfaces make the vehicle very modular and provide easy access to virtually all of the vehicle's interior. The design of the connection to the wheels, articulation joints, and boom differ only in scale. The articulation joints and wheels use 18" diameter interfaces, and the boom uses a 12" diameter interface.

IV.5 ACHIEVEMENTS

- 1.) All internal load carrying structures were removed
- 2.) The center section design is modular
- 3.) The skin thickness was determined to be 1/8"
- 4.) Interfaces to wheels, articulation joints, and boom were designed

V. V-CLAMP ASSEMBLY DESIGN

V.1 INTRODUCTION

The V-clamp assembly is designed to provide a simple connection for the main components of the vehicle (see drawings VC-1 and VC-2). The purpose behind the V-clamp is to eliminate the need for bolts. The advantage from this is that the main components of the vehicle can be easily replaced by hand without the use of tools. There are two different sizes of V-clamps that will be used on the vehicle. The largest V-clamp is 18 inches in diameter and will be used on the chassis (see drawing VC-5 and VC-7). Its main function is to connect the front, center, and rear sections of the vehicle to the wheels and articulation joints. A V-clamp is also used to attach the face plate onto the front chassis section. The smaller V-clamp is 12 inches in diameter and is used on the boom structure (see drawing VC-6 and VC-8). Its main function is to connect the boom to the chassis, and provide an interface between the articulation joints and elbow joints of the boom.

V.2 CONSTRAINTS ON DESIGN

- 1.) V-clamp must be recessed so that its maximum diameter does not extend beyond the maximum diameter of the tube to which it is connected.
- 2.) The V-clamp support rings must be designed so that torque in the axial direction will not cause the adjoining sections to rotate with respect to one another.
- 3.) The V-clamp support rings must be designed to be as light as possible.
- 4.) The support rings must be able to interface with the articulation joint bearing, chassis sections and the wheel assembly.
- 5.) The support rings must be designed so that they will interface properly with the V-clamp part numbers V0916300N-1800-S4 (18 inch diameter clamp) and V0916300N-1200-S4 (12 inch diameter clamp).
- 6.) The mating supporting rings must be designed to be interlocking with an internal shoulder so that the support rings and not the V-clamp support the transmitted shear load.

V.3 ANALYSIS AND DESIGN

Material:

The material to be used for the support rings is Aluminum 6061-T6. The reason for this is due to its strength to weight ratio. It is lighter than steel, and can also be welded. Aluminum 6061-T6 is also easily machined which is a great advantage since the support rings will be machined from stock aluminum. The V-clamp will be stainless steel.

Female Support Ring:

The female support ring is designed with an internal shoulder so that when the male support ring is mated against it, the shoulder will support the transmitted shear stress and not the V-clamp. The female support ring contains eight bolt holes so that it can be connected to the articulation joint bearing. A 3/4 inch flange with 1/8 inch rivet holes is also designed as part of the ring so that it can be inserted into the end of the chassis sections. This part is to be machined according to drawing specifications. (see drawings VC-3, VC-4, VC-5, and VC-6)

Male Support Ring:

The male support ring is designed so that it can mate up flush against the female support ring. The male support ring has a 1/4 inch stud that inserts into one of the eight bolt holes of the female ring. The purpose of this stud is to prevent axial rotation when a torque is placed on one half of the assembly. The male support ring is designed with a 3/4 inch flange containing 1/8 inch rivet holes. This flange can be inserted into the wheel assembly or boom elbow sections depending upon the application. This part is to be machined according to drawing specifications. (see drawings VC-3, VC-4, VC-7 and VC-8)

V-clamp:

The V-clamps will be purchased from Clampco Products, Inc. The V-clamps will come in two separate sizes. The 12 inch diameter V-clamp will be used for the boom assembly, and the 18 inch diameter V-clamp will be used for the chassis assembly. The purpose of the V-clamp is to connect

the male and female support rings. Due to the design of the support rings, the V-clamp will not support any of the shear load, but it will be responsible for resisting bending and tension stresses. The 18 inch V-clamp is capable of supporting 110 psi whereas the 12 inch V-clamp is capable of supporting 180 psi. This V-clamp selection provides a minimum factor of safety of 4.62.

The V-clamp part numbers are as follows:

18 inch V-clamp V0916300N-1800-S4

12 inch V-clamp V0916300N-1800-S4

These V-clamps are composed of the following components and specifications:

- 1.) Medium duty over center latch
- 2.) One retainer segment
- 3.) 63 retainer series cross section
- 4.) Standard design
- 5.) 18-8 stainless steel bolt
- 6.) 18-8 stainless steel nut/self locking
- 7.) .062 stainless steel V-band

Each assembly of V-clamp, male support ring, and female support ring has a total weight of 12 pounds for the 18 inch diameter, 10 pounds for the 12 inch diameter and axial exposed length of 3 inches for both diameters.

(see drawings VC-1 and VC-2)

V.4 ACHIEVEMENTS

- 1.) The female support ring is capable of attaching to both the articulation bearing and the chassis skin. The male support ring is capable of attaching to the wheel assembly skin and boom elbows.
- 2.) The support rings prevent axial rotation of adjoining sections due to slip caused by external torque's.
- 3.) The V-clamp does not extend beyond the maximum diameter of the adjoining sections.
- 4.) The support rings carry the shear load and the V-clamp resists the bending and tension stresses.
- 5.) The support rings provide the necessary interface to accommodate the V-clamp.

VI. BOOM STRUCTURE

VI.1 INTRODUCTION

When designing a system, the design of each component becomes dependent upon the operation and configuration of the other parts. The design of the boom is especially difficult since loading on the boom will not only affect the boom itself, but also the chassis. The goal of this project was to produce a practical design for future use by Georgia Tech students and researchers.

For boom design, it was necessary to first determine which boom positions give the worst-case loading. From these characteristics, a composite was initially analyzed for its high strength-to-weight ratio.

Following an extensive design analysis, aluminum-6061 was chosen to provide similar characteristics to a composite with similar weight and easier fabrication.

VI.2 UPPER BOOM DESIGN

VI.2.1 INTRODUCTION

The upper boom is the largest portion of the boom apparatus attached to the enabler vehicle. The design was governed primarily by strength, weight, compatibility with articulation joints. The upper boom is in the shape of a hollow, tapered cylinder so that loads applied to it are distributed throughout a circular cross-section. Members with circular cross-sections possess strength and stiffness characteristics which are distributed in all directions throughout the cross-section. The torsional characteristics of circular members are also desirable. This is very advantageous due to the boom's four-degree-of-freedom movement.

VI.2.2. CONSTRAINTS ON DESIGN

- 1.) Be able to support a minimum 10-lb load in the most critical position
- 2.) Maximize structural strength with minimal weight
- 3.) Maintain balance of vehicle
- 4.) Maintain geometric compatibility of elbows with articulation joints
- 5.) Ensure length of entire boom assembly in stowed position does not exceed 2/3 of the entire length of the vehicle.

VI.2.3 ANALYSIS AND DESIGN

The upper boom was analyzed using two methods: manual calculations and finite element analysis. The finite element analysis is described in Section VIII, Computer Analysis.

The manual calculations began initially with a force and moment analysis on the boom as it was fixed at critical positions. The most critical position consisted of the entire boom assembly outstretched perpendicular to the chassis (see drawing SM-6). Due to concern for vehicle tipping, the entire boom assembly was restricted to $2/3$ the length of the entire chassis, or 12'. This then dictated the length of the upper boom, which is 10.7'. The large diameter of the tapered portion was fixed at 12" so that the upper boom would mate with the articulation joints and elbows. The small diameter of 4" established a uniform taper along the length of the boom.

The material selected to construct the boom is aluminum-6061-T6. The criteria for selecting this material is discussed in Section VI, Materials Selection. A yield stress of 8000 psi was used in the stress analysis of the upper boom. This is the yield stress used when the material is welded. The decision was made to use that value because the boom will more than likely be constructed from aluminum sheet metal and will have to be welded or riveted along its length to hold the tapered cylindrical shape. The taper can be constructed by a flagpole company that specializes in fabricating nonstandard designs.

A stress analysis was performed to find an acceptable thickness for the upper boom. In order to perform this analysis, the upper boom was modeled as a cantilever beam with an applied load at the free end and a rectangular weight distribution. Using results from the force and moment

analysis and relations for shear and normal stress, it was found that a thickness of 1/16" would satisfy the objectives. A tapered boom, 1/16" thick and 10.7' long supported the 10-lb minimum load with a weight of 20-lb.. Stress calculations were performed at several points along the boom to ensure that there was no risk of failure and that a safety factor of 1.5 was preserved. Shear stress analysis revealed that the shear stress in the boom was small in comparison to the bending stresses and therefore could be given less consideration. (See Appendix XI.2 , Hand-Done Calculations).

A dead load analysis was performed to make sure that the upper boom would not fail under its own weight. The weight distribution of the upper boom is not linear. Therefore, after advisement from Dr. Lawrence Jacobs, the upper boom was modeled as a combination of a rectangular and triangular load distribution. The boom was modeled as a cylindrical boom with a constant circular cross section of outer diameter equal to 4 in. and thickness equal to 1/16 in. This is a worst case assumption because a wider beam would not deflect as much. The total dead load deflection was found to be 1.04 in. This was found using the principle of superposition and adding the deflections due to each of the load distributions. Modeling the boom as a cantilever beam with an applied load of 10 lb on the end revealed a deflection of .91 in. The same cross section was used. This is a tolerable deflection. The maximum load capability was found to be 29 lb. This was calculated by modeling the boom as a cylinder with constant outer diameter equal to 6 in. and a thickness of 1/16 in. This was chosen as a medium between the 4 in and the 12 in outer diameters in order to give a reasonable estimate. (See Appendix XI.2, Hand-Done Calculations)

VI.2.4 ACHIEVEMENTS

- 1.) Finalized dimensions of upper boom including a manufactured material thickness of 1/16" (See Figure BM-1)
- 2.) Chose material for construction
- 3.) Minimized weight of upper boom to 20 lb.
- 4.) Achieved a factor of safety of 1.5
- 5.) Determined that the upper boom will support a load of 29 lb.
- 6.) Contacted possible sources for fabrication (particularly, Eder Flagpole Company, which will manufacture a tapered beam to specifications)
- 7.) Ensured compatibility with entire boom assembly

VI.3 LOWER BOOM DESIGN

VI.3.1 INTRODUCTION

The lower boom is the smaller of the two main boom sections in the enabler vehicle. It consists of a hollow cylinder due to the load support properties of cylindrical members (see previous section for description). The strength and stiffness characteristics of members with circular cross-sections are distributed in all directions throughout the cross-section. Circular cross-sections also possess desirable properties for torsional resistance and strength. This serves the purpose well since the boom assembly moves with four degrees-of-freedom. The cylindrical design also makes the boom compatible with the elbows and articulation joints. The design for the lower boom was influenced by the design of the upper boom, the articulation joint between the two boom sections and the elbows.

The design for the lower boom was governed by strength, weight, vehicle tipping and practical construction considerations.

VI.3.2 CONSTRAINTS ON DESIGN

- 1.) Be able to support upper boom, elbows, articulation joint, and a 10-lb applied load in the most critical position.
- 2.) Maximize structural strength with minimal weight
- 3.) Maintain balance of vehicle
- 4.) Ensure compatibility with elbows and articulation joints
- 5.) Ensure length of entire boom assembly in stowed position should not exceed $2/3$ of the entire length of vehicle.

VI.3.3 ANALYSIS AND DESIGN

The lower boom was analyzed using two methods: manual calculations and finite element analysis. The finite element analysis is discussed in Section VIII, Computer Analysis.

The first step in the hand calculation method for the lower boom was a static analysis to determine the forces and moments on the boom as a result of the weights of the upper boom, the elbows, the articulation joint and the 10-lb applied load. The critical position for the lower boom consists of the following:

- 1.) The boom assembly fully extended perpendicular to the vehicle;
and
- 2.) For torsional analysis, the upper boom is rotated 90 degrees relative to lower boom.

(See Appendix XI.1 for graphical representation).

Due to the restriction of the boom assembly's length to $2/3$ the length of the vehicle, the length of the lower boom was determined to be 4.5'. The material selected to construct the boom was aluminum-6061-T6. The basis for this selection is discussed in Section VII, Materials Selection.

Stress and torsional analyses were performed to determine the thickness for the lower boom. The boom was modeled as a cantilever beam with the weights of the upper boom, elbows, articulation joint and a 10-lb applied load acting on the beam. The resulting analysis gave a thickness of $1/8$ " to satisfy the objectives. The weight of the lower boom was calculated to be 25 lb. Since the lower boom is of a constant cross-section, the point of greatest stress is located at the point of largest moment. This point is located at the end of the lower boom where it connects to the articulation joint. Shear and torsional analysis showed that those stresses were small compared to the bending stress and could be considered subordinate. A factor of safety of 1.5 was used in the design of the lower boom. (See Appendix XI.2, Hand-Done Calculations)

A dead load analysis was performed on the lower boom to ensure that it would not fail under its own weight. The boom was modeled as a cantilever beam with a rectangularly-distributed weight applied along the length of the boom. The deflection of the lower boom with the entire assembly and applied load was determined to be acceptable. (See Appendix XI.2, Hand-Done Calculations)

VI.3.4 ACHIEVEMENTS

- 1.) Finalized dimensions of lower boom including a standard manufactured material thickness. (See Figures BM-2, BM-3)
- 2.) Chose material for construction
- 3.) Minimized weight of lower boom to 25 lb.

- 4.) Achieved a factor of safety of 1.5
- 5.) Determined that the lower boom will support the entire load assembly with maximum applied load to upper boom
- 6.) Ensured compatibility with entire boom assembly

VI.4 ELBOWS

The elbows were designed to connect the upper and lower boom to the articulation joint between them and to connect the lower boom to the lower articulation joints and the chassis. The elbows will be fabricated from 1/8 in. thick 6061 T6 Aluminum so that they will connect to the articulation joints using the V clamp design conceived this quarter. Two possible methods to construct the 90 degree elbows were considered. The basic construction consist of a hollow cylinder with a thickness of 1/8 in. The two options are to either cut the cylinder at 45 degree angles and weld them together to form a 90 degree turn or to bend the cylinder 90 degrees with a fillet. The deciding factors will probably be ease of fabrication and cost. The dimensions of the elbows are shown on drawings of the individual parts. (See Figures BM-4, BM-5) Drawings of the bent elbows can be seen by referencing the Winter '92 Boom and Tool Interface Design report. A special consideration in the design of the 45 degree elbows was to achieve a certain clearance between the bottom of the lower boom and the top of the chassis. This clearance was dictated by wheel height, height of the rear T section when the rear articulation joint is rotated into the up position, and the deflection of the boom in the stowed position. The same two options for fabrication apply to the 45 degree elbows as do the 90 degree elbows. The difference is that the cuts would be at 22.5 degree angles and the bend would be a 45 degree bend.

VII. MATERIAL SELECTION

The main concern with selecting a material for the enabler is that it must have a high strength to weight ratio. Other factors to consider is that the material must be weldable, readily available, easily machined and reasonably priced in comparison to materials with similar properties. The construction material previously selected for the enabler was AISI 1020 steel. Although this steel meets the outlined requirements, its major drawback is weight.

Due to this factor, other materials were investigated to find a material more suitable for the enabler. The other materials looked at were composites and aluminum alloy including honeycomb aluminum. Of these materials, the composites and honeycomb aluminum were eliminated due to the cost. Further investigation revealed that 6061-T6 aluminum alloy was the best choice. Its density is $.098 \text{ lb/cu}^3$ which is a great advantage over the $.283 \text{ lb/cu}^3$ of AISI 1020 steel. For an equal volume of material the aluminum is only one-third the weight of steel. Another amazing factor is that the yield strength of 6061-T6 aluminum is greater than the yield strength of AISI 1020 steel. The yield strength of the aluminum is 35 kpsi versus only 30 kpsi of the steel. This data makes it very apparent that the strength to weight ratio of the aluminum is much greater than that of steel. The other advantage of the 6061-T6 aluminum is that it can be welded and is readily available at a competitive cost. The only major drawback of using the 6061-T6 aluminum is that its yield strength is cut in half after welding. During the welding process, the aluminum is annealed at the joints and assumes the characteristics of 6061-O aluminum in these welded regions. This aluminum still maintains its same density,

but the yield stress is reduced from 35 kpsi to 8 kpsi. For this reason 8 kpsi was used as the yield stress for all calculations.

VIII. WEIGHT COMPUTATIONS

The weights of the Enabler chassis and boom structures are maximums based on geometrical estimates of the volume. Since the density of aluminum 6061 is 0.098 lb/in³, most cut away material was assumed to be part of the structure for weight computations. A table of weights is shown below.

Part	Quantity	Weight (each)	Weight (total)
Front cross section	1	28 lb	28 lb
Center cross section	1	28 lb	28 lb
Rear cross section	1	45 lb	45 lb
Chassis V-clamp assy.	11	15 lb	165 lb
Lower boom	1	25 lb	25 lb
Upper boom	1	20 lb	20 lb
45° elbows	2	8 lb	16 lb
90° elbows	2	11 lb	22 lb
Boom v-clamp assy.	8	10 lb	80 lb
Total weight			429 lb

Chassis Weights

For the chassis sections, the component cylinders were assumed to be complete cylinders made from 1/8" thick aluminum 6061. For the front and center section of the vehicle, these cylinders were 10.25" long. The volume and weight of four of these cylinders was used to determine a

maximum weight for the section of the chassis. For the rear section, three of the 10.25" long cylinders were used with a cylinder 20.25" long and box (12" x 12" x 26") to compute the volume and weight of the section. The calculations for these weights are shown in figure WC-1.

V-clamp Weights

The weights of the v-clamp assemblies were computed by taking the area of the cross-section of the support ring and multiplying by the circumference at the centroid of the cross-section and the density of aluminum. The cross-sectional area, obtained from AutoCAD, was 2.4582 square inches. For the rings in the chassis, the circumference used was 50.25"(based on the centroid being 8" from the center of the ring). This yielded a weight of 12 pounds (as shown in figure WC-2). The circumference used for the boom was 31.4" (based on the centroid being 5" from the center of the ring). This yield a weight of 7.6 pounds (as shown in figure WC-3).

Weight of elbow sections

Each elbow section of the boom consists of two cylinders with one end cut at an angle. The material removed by the cut in each cylinder was ignored to compute the weight. A total length for the cylinders which form the elbow was found. In the 90° elbows, the total length was 24 inches. For the 45° elbows, the total length was 17 inches. The weight of each type of elbow was calculated as shown in figures WC-4, and WC-5.

Weight of the upper boom

The weight of the upper boom was calculated by finding the surface area of the boom using a standard formula for tapered cylinders. The surface area of the upper boom was then multiplied by the thickness of the skin to get the volume of the boom. Multiplying the volume by the density of aluminum yielded a weight of 20 pounds (as shown in figure WC-6).

Weight of the lower boom

The volume of the lower boom was computed using the formulas for hollow cylinders. The volume of the lower boom was multiplied by the density of aluminum. A weight of 25 pounds was arrived at as shown in figure WC-7.

Figure WC-1

Weight of chassis end section

$$\text{Diameter} := 18 \cdot \text{in} \qquad \text{Thickness} := 0.125 \cdot \text{in}$$

$$\text{Area} := \pi \cdot \left[\left[\frac{\text{Diameter}}{2} \right]^2 - \left[\frac{\text{Diameter} - 2 \cdot \text{Thickness}}{2} \right]^2 \right]$$

$$\text{Volume} := \text{Area} \cdot (20.25 \cdot \text{in} + 20.25 \cdot \text{in})$$

$$\text{Wchassis} := \text{Volume} \cdot \text{Density}$$

$$\text{Wchassis} = 27.86 \cdot \text{lb}$$

Figure WC-2

Weight of chassis V-clamp support rings

$$\text{Area} := 2.4582 \cdot \text{in}^2 \qquad \text{From AutoCAD}$$

$$\text{Diameter} := 15.99 \cdot \text{in}$$

$$\text{Volume} := \pi \cdot \text{Diameter} \cdot \text{Area}$$

$$\text{Weight} := \text{Density} \cdot \text{Volume}$$

$$\text{Weight} = 12.102 \cdot \text{lb}$$

Weight of boom V-clamp support rings

$$\text{Area} := 2.4582 \cdot \text{in}^2 \qquad \text{From AutoCAD}$$

$$\text{Diameter} := 9.998 \cdot \text{in}$$

$$\text{Volume} := \pi \cdot \text{Area} \cdot \text{Diameter}$$

$$\text{Weight} := \text{Density} \cdot \text{Volume}$$

$$\text{Weight} = 7.567 \cdot \text{lb}$$

Figure WC-4

Weight of 90 elbow segment

$$OR := 6 \cdot \text{in}$$

$$IR := 5.875 \cdot \text{in}$$

$$\text{Area} := \pi \cdot [OR^2 - IR^2]$$

$$\text{Volume} := \text{Area} \cdot 24 \cdot \text{in}$$

$$\text{Weight} := \text{Density} \cdot \text{Volume}$$

$$\text{Weight} = 10.968 \cdot \text{lb}$$

Figure WC-5

Weight of 45 elbow segment

$$OR := 6 \cdot \text{in}$$

$$IR := 5.875 \cdot \text{in}$$

$$\text{Area} := \pi \cdot [OR^2 - IR^2]$$

$$\text{Volume} := \text{Area} \cdot 14.5 \cdot \text{in}$$

$$\text{Weight} := \text{Density} \cdot \text{Volume}$$

$$\text{Weight} = 6.627 \cdot \text{lb}$$

Figure WC-6

Weight of the Upper Boom

$$\text{Tipdiameter} := 4 \cdot \text{in}$$

$$\text{Basediameter} := 12 \cdot \text{in}$$

$$l := 126 \cdot \text{in}$$

$$\text{Thickness} := 0.0625 \cdot \text{in}$$

$$\text{Surfacearea} := \pi \cdot \left[\frac{\text{Tipdiameter} + \text{Basediameter}}{2} \right] \cdot l$$

$$\text{Volume} := \text{Surfacearea} \cdot \text{Thickness}$$

$$\text{Weight} := \text{Volume} \cdot \text{Density}$$

$$\text{Weight} = 19.396 \cdot \text{lb}$$

Figure WC-7

Weight of the Lower Boom

$$\text{Diameter} := 12 \cdot \text{in}$$

$$\text{Thickness} := 0.125 \cdot \text{in}$$

$$\text{Length} := 54 \cdot \text{in}$$

$$\text{Volume} := \frac{\pi}{4} \cdot \left[\text{Diameter}^2 - (\text{Diameter} - 2 \cdot \text{Thickness})^2 \right] \cdot \text{Length}$$

$$\text{Weight} := \text{Volume} \cdot \text{Density}$$

$$\text{Weight} = 24.678 \cdot \text{lb}$$

**XI. COMPUTER ANALYSIS
(FINITE ELEMENT)**

TABLE OF CONTENTS FOR COMPUTER ANALYSIS:

Introduction	CA - 2
Analysis Process	CA - 2
Weight Data	CA - 2
Material Data	CA - 2
Definitions of Critical Boom Positions	CA - 3
Upper Boom:	
Assumptions	CA - 4
Diagram List	CA - 4
Results	
Deflection.....	CA - 4
Beam Stress	CA - 4
Cross Sectional Stress	CA - 4
Lower Boom:	
Assumptions	CA - 5
Diagram List.....	CA - 5
Results	
Deflection	CA - 5
Beam Stress	CA - 5
Cross Sectional Stress	CA - 5
Chassis:	
Assumptions	CA - 6
Diagram List	CA - 6
Results	
Deflection	CA - 6
Beam Stress	CA - 6
Cross Sectional Stress	CA - 6

Introduction:

All of the major Boom and Chassis components were analyzed using a finite element software package. I-deas VI was the software package used in the analysis. This package can be found at the computer cluster located in Room 104 of the French Building. The chassis and boom structures were analyzed for deflections, longitudinal beam stresses, and cross sectional beam stresses.

Analysis Process:

A cross section of the object being analyzed was produced and then meshed. The mesh was then repeated every 3 inches until the end of the beam was reached. The beam was then constrained and loaded at the desired points. Once, the boundary conditions were added, the beam analysis was performed. Post-processing had to be done in order to obtain the final results.

Weight Data (Based on some assumptions - see individual sections):

Upper Boom Weight : 40 lbs.

End weight : 10 lbs.

Lower Boom Weight : 60 lbs.

Articulation Wt. : 48 lbs. (each)

Total Boom Weight : 254 lbs. (includes articulation joints)

Material Data :

Material : Aluminum 6061 - T0

$E = 10 \times 10^6 \text{ lbs./in}^2$

$S_y = 8 \times 10^3 \text{ lbs./in}^2$

Note: The material characteristics of Aluminum 6061 - T0 was used instead of Aluminum 6061 - T6 because of the annealing that occurs when the joints are welded.

Definitions Of Critical Boom Position:

While designing the boom and chassis sections, three main critical positions of the boom were considered as worse cases. Positions and descriptions are as follows:

Position 1 : (see page CA - 7)

Position 1 has both booms extended directly out to the side of the vehicle. Specified by Mr. Brazell, one of the conditions of this position is that all six wheels must be in contact with the ground. This will play a large part when defining the boundary conditions for the finite analysis.

Position 2 : (see page CA - 8)

Position 2 has the upper boom at a 90° angle to the lower boom. In position 2, the lower boom is subjected to the maximum amount of torsional stress.

Position 3 : (see page CA - 9)

Position 3 has the boom in the "stored" position. The important thing to note is that the middle wheels are not in contact with the ground. This is to simulate the vehicle bridging a crevice. Also, as stated before, the boom can not be extended with the wheels in this position, because all of the wheels are not in contact with the ground. This position will tend to put the largest amount of stress on the end sections.

Upper Boom:

Assumptions

1. The upper boom was modeled as a straight beam with a constant cross section (not a tapering boom).
2. The outside diameter of the entire beam was 4".
3. The weigh of the upper boom was modeled as 40 lbs. The 40 lbs. contains 20 lbs. for the actual weight of the boom and 20 lbs. for extras (wiring and such).
4. The force from the weight was placed half-way along the length of the beam. Although in actuality, the force will be closer to chassis.

Note: All of the assumptions made were conservative, therefore, the results of the analysis will be worse case scenarios.

Diagrams

<u>Diagram</u>	<u>Graph</u>
Cross Section Mesh	CA - 10
Beam Representation	CA - 11
Force Diagram	CA - 12
Deflection Diagram	CA -13
Longitudinal Stress Diagram	CA - 14
Cross Sectional Stress Diagrams	CA - 15

Note : Positioning does not matter for upper boom.

Results

Maximum Deflection :	1.5 "
Maximum Stress :	5375.81 psi
Factor of Safety :	1.5

Lower Boom:

Assumptions

1. The entire lower boom (including the 90° and 45° elbows) was modeled as single beam.
2. The center of gravity of the piece was assumed to be at the half-way point of the length of the beam.
3. Articulations motors are to be placed 12" from the fixed end (nearest chassis) of the beam and 6" from the free end (nearest upper boom).

Diagrams

<u>Diagram</u>	<u>Graph</u>
Cross Section Mesh	CA - 16
Beam Representation	CA - 17
Force Diagram	CA - 18,19 (P1,P2)
Deflection Diagram	CA - 20,21 (P1,P2)
Longitudinal Stress Diagram	CA - 22,23 (P1,P2)
Cross Sectional Stress Diagrams	CA - 24,25 (P1,P2)

(P1 = Position 1 , P2 = Position 2)

Results

Maximum Deflection :	.036"	(P1)
Maximum Stress :	1018.29 psi	(P1)
Factor of Safety :	7.86	

Chassis:

Assumptions

1. The entire chassis (including the cross sections and articulation joints) were modeled as a single beam.
2. The weights from the articulation joints were placed half-way between the center cross section and the end sections.
3. For Position #1, when the boom is extended, it is assumed that all six wheels will be in contact with the ground.
4. For Position #3, the middle wheels are not in contact with the ground. This positioning will simulate the maximum forces encountered when bridging a crevice.

Diagrams

<u>Diagram</u>	<u>Graph</u>
Cross Section Mesh	CA - 26
Beam Representation	CA - 27
Force Diagram	CA - 28,29 (P1,P3)
Deflection Diagram	CA - 30,31 (P1,P3)
Longitudinal Stress Diagram	CA - 32,33 (P1,P3)
Cross Sectional Stress Diagrams	CA - 34,35 (P1,P3)

(P1 = Position 1 , P3 = Position 3)

Results

Maximum Deflection :	.008"	(P3)
Maximum Stress	375.06 psi	(P3)
Factor of Safety :	21.33	

SDRC I-DEAS VI: Solid_Modeling

Database: none
View: No stored View
Task: Object
Object: I-WORK1. (VERTICAL_PLAT)

03-JUN-92 20:58:09

Units: IN
Display: No stored Option

Bin: I-WORK1
Update Level: Full

Position 1

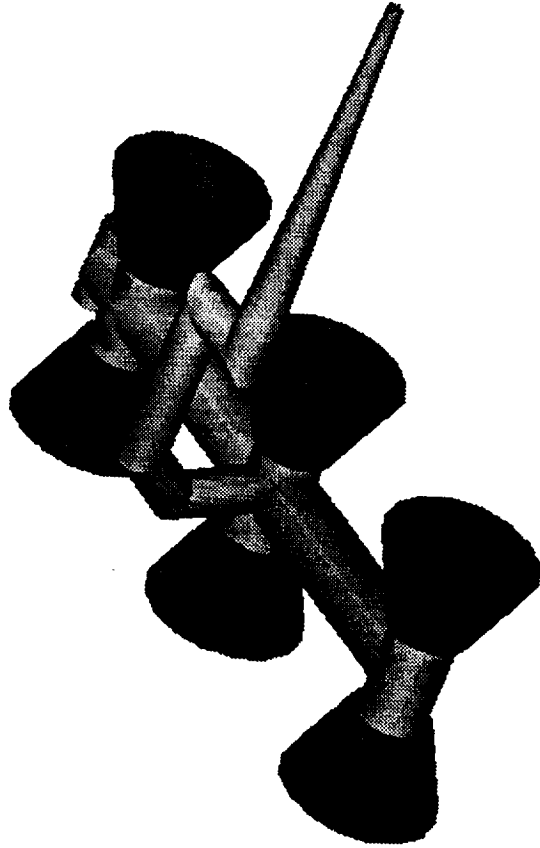

NOTES:

ALL SIX WHEEL
ARE IN CONTACT WITH
GROUND IN THIS POSITION

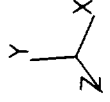

Database: none
View: No stored view
Task: Object
Object: I-MODEL. (HEAP, P14) (Mod)

SDRC I-DEAS VI: Solid_Modeling

04-JUN-92 12:55:43

Display: No stored option
Units: IN
Bin: I-MATH
Options Level: P01

Position Z

NOTES:
POSITION USED MAINLY
TO ACHIEVE TORSIONAL
EFFECT ON LOWER
BEAM.

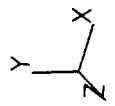
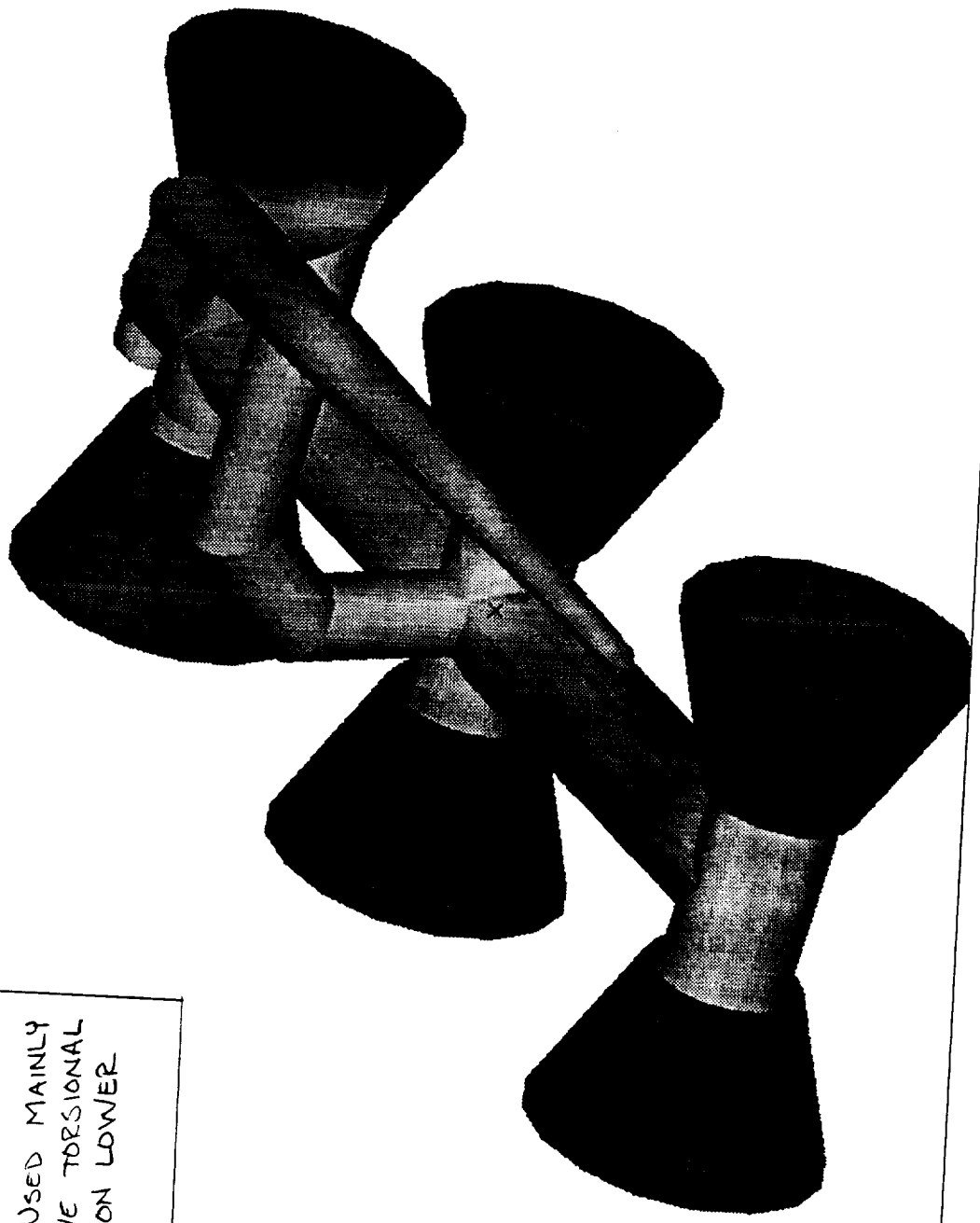

04-JUN-92 13:05:40 Units: IN

SDRC I-DEAS VI: Solid_Modeling

Database: none
View: No stored view
Task: Object
Object: F-MODEL (RT, BIAS) (MOD)

Bin: 1-3012
Update Level: Full

Display: No stored option

POSITION 3

NOTES:
MIDDLE WHEELS
ARE NOT IN CONTACT
WITH GROUND
(CREVICE BRIDGING).

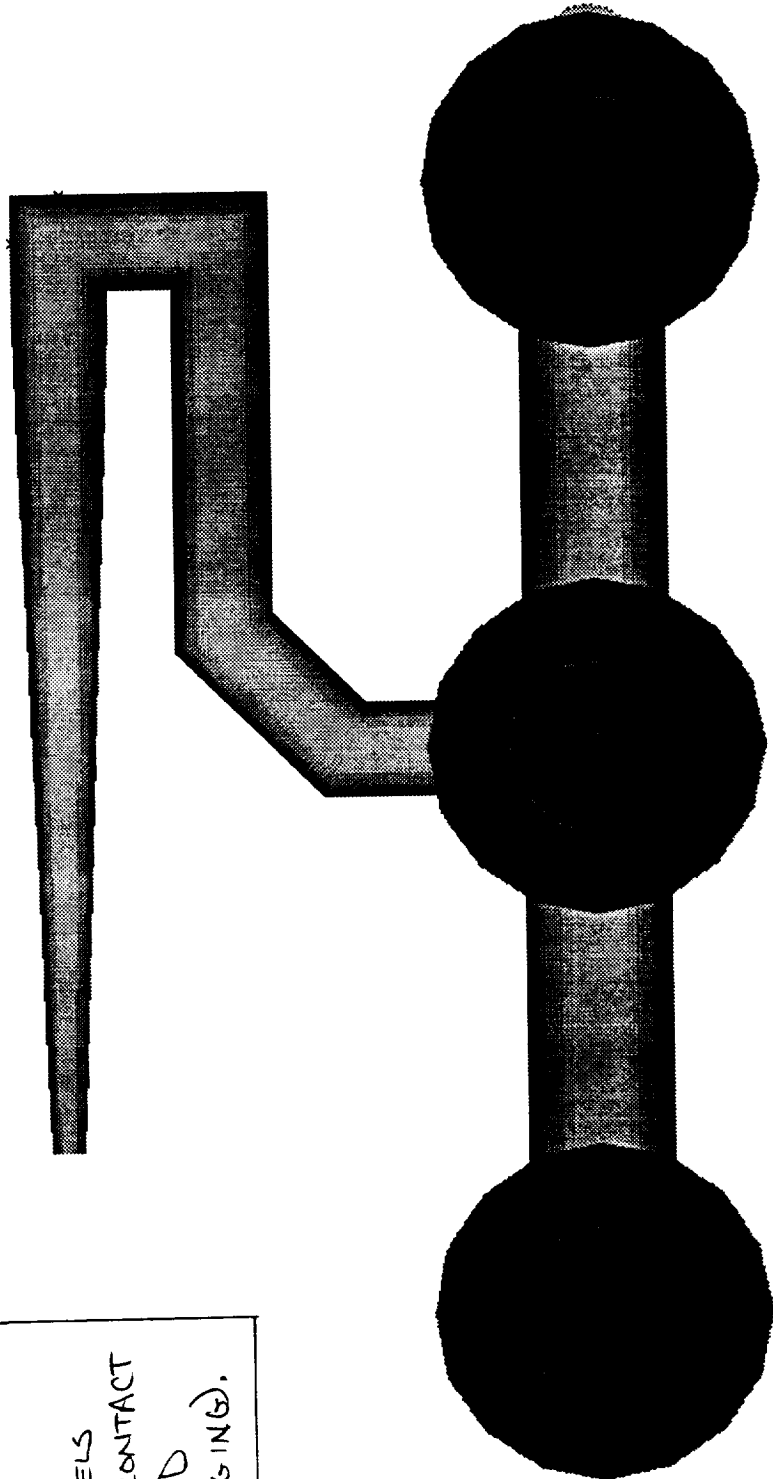

SDRC I-DEAS VI: FE_Modeling_&Analysis

Database: none
View : No stored View
Task: Beam Properties
Model: 3-FE MODEL3

10-JUN-92 10:59:11

Units : IN

Display : No stored Option

Model Bin: 1-MAIN

Associated Workset: 3-WORKING_SET3

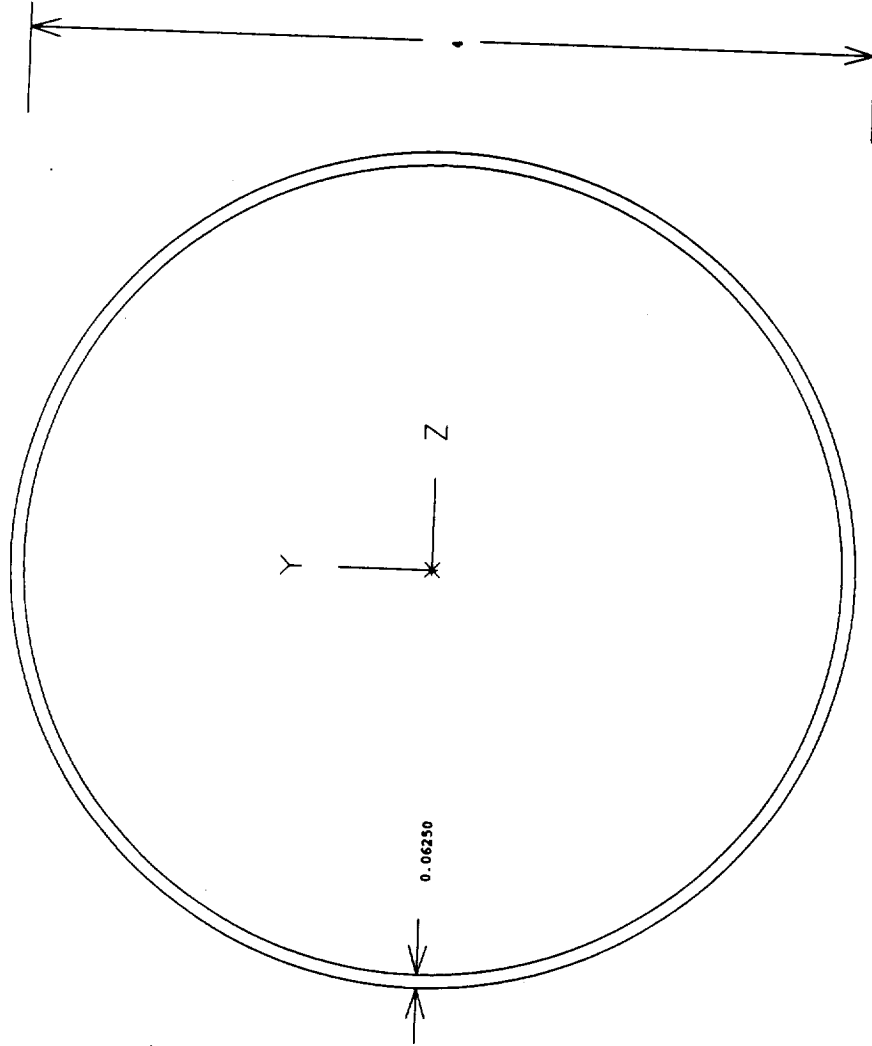

UPPER BOOM - CROSS SECTION MESH

BY: JASON S. DELL

SDRC I-DEAS VI: FE_Modeling_&Analysis

Database: none
View : No stored View
Task: Boundary Conditions
Model: I-FE MODEL1

05-JUN-92 11:25:44

Units : IN
Display : No stored Option
Model Bin: I-MAIN
Associated Worksheet: I-WORKING_SET1

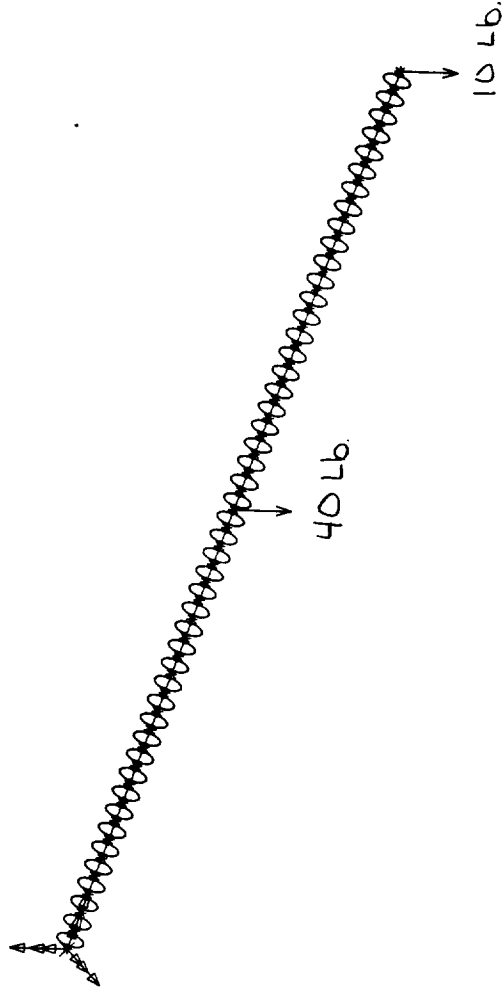

UPPER BOOM - BEAM REPRESENTATION

BY: JASON S. DELL

SDRC I-DEAS V1: FE_Modeling_4_Analysis

Database: none
View : No stored View
Task: Boundary Conditions
Model: 1-FE MODEL1

05-JUN-92 11:24:47
Units : IN
Display : No stored Option
Model Bin: 1-MAIN
Associated Worksheet: 1-WORKING_SECT1

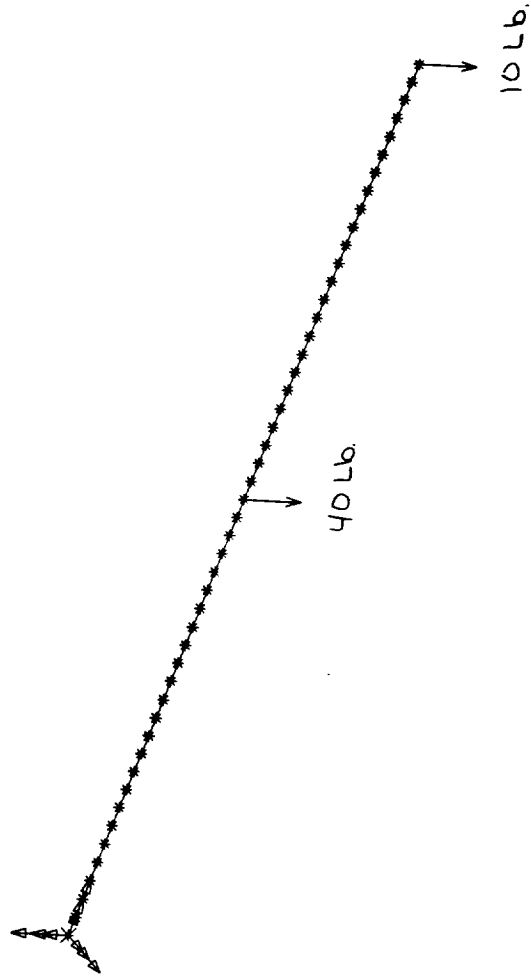

UPPER BOOM - FORCE DIAGRAM

BY: JASON S. DELL

CA-17

SDRC I-DEAS VI: FE_Modeling & Analysis

Database: none
View : No stored View

Task: Post Processing
Model: 1-FE MODEL1

04-JUN-92 19:23:12

Units : IN
Display : No stored Option
Model Bin: 1-MAIN
Associated Worksheet: 1-WORKING_SET1

LOAD SET: 1 - LOAD SET 1
DISPLACEMENT - NORMAL MIN: 0.00 MAX: 1.50

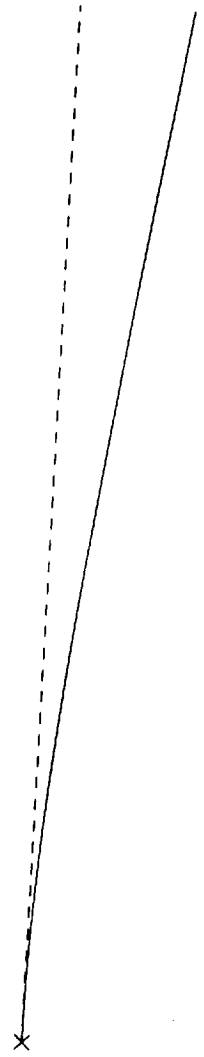

NOTE:
DRAWING IS
SCALED

UPPER BOOM - DEFLECTION

BY: JASON S. DELL

CA-13

04 JUN 92 19:26:21

SDRC I-DEAS VI: FE_Modeling_& Analysis

Database: none
View : No stored View
Task: Post Processing
Model: 1-FE MODEL1

04-JUN-92 19:26:21
Units : IN
Display : No stored Option
Model Bin: 1-MAIN
Associated Workset: 1-WORKING_SET1

LOAD SET: 1 - LOAD SET 1
FRAME OF REF: GLOBAL
STRESS - MAX PRIM MIN: 24.37 MAX: 6084.95

none

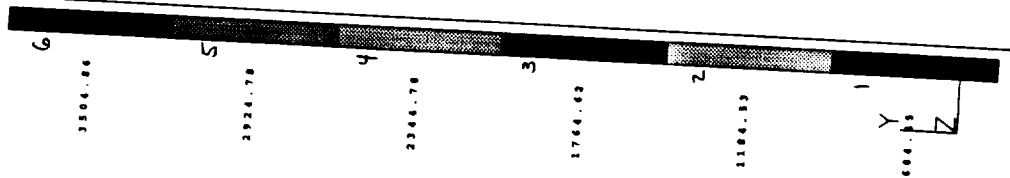

UPPER BOOM - LONGITUDINAL BEAM STRESS

BY JASON S. DELL

CA-111

SDRC I-DEAS VI: FE_Modeling_& Analysis

Database: none

View : No stored View

04-JUN-92

19:40:43

Units : IN

Display : No stored Option

LOAD SET: 1 - LOAD SET 1
BEAM 3 AT MAX POSITION STRESS
FX = 0.00 FY = -50.00 FZ = 0.00
MX = 0.00 MY = 0.00 MZ = -4020.00
BEAM 1-SECTION - VON-MISES STRESS MIN: 221.41 MAX: 5375.03

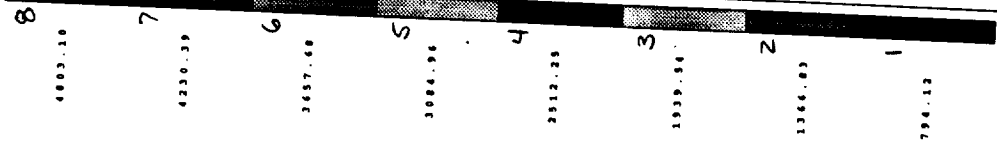
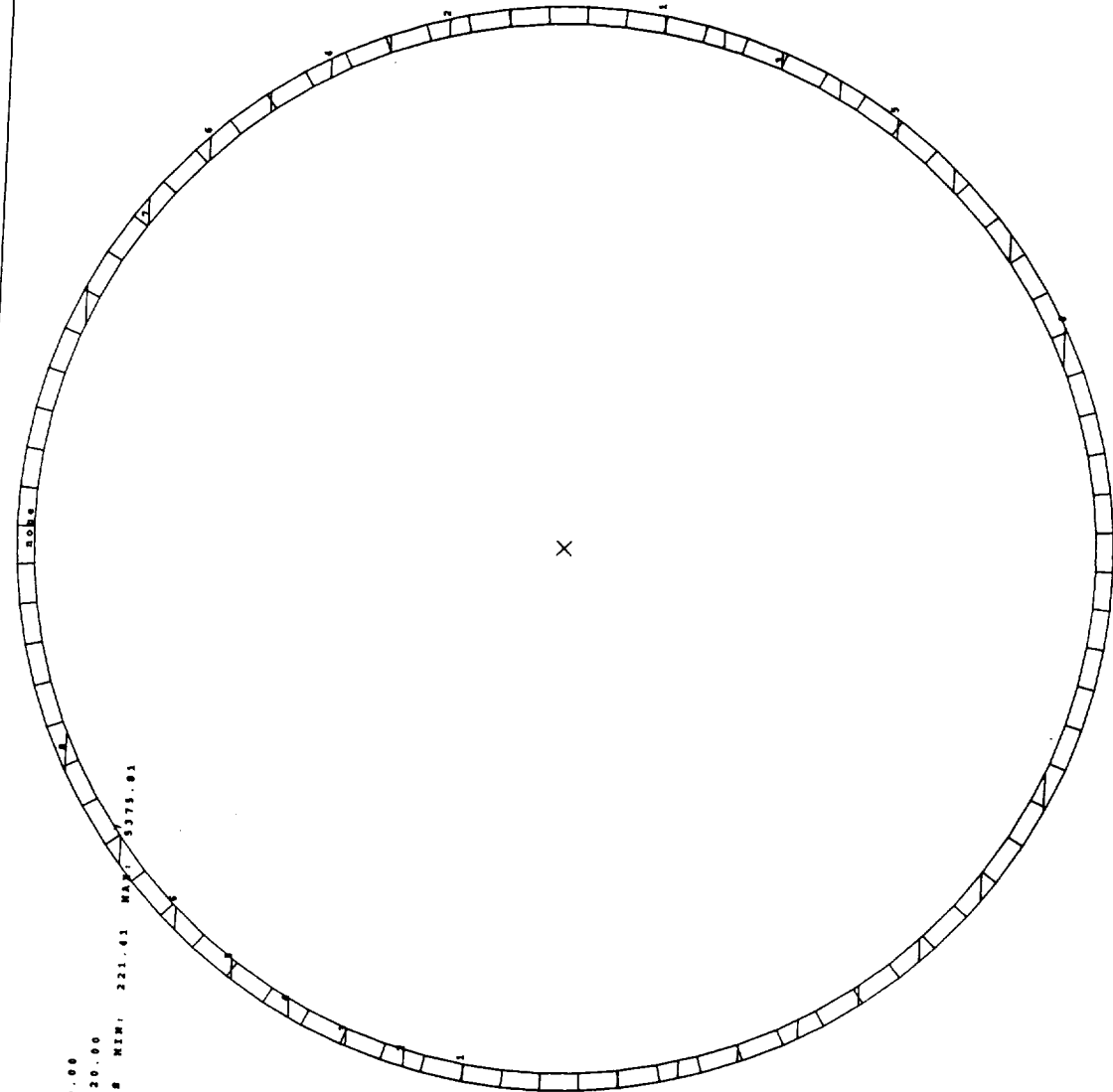

UPPER BOOM - CROSS SECTIONAL STRESS

BY: JASON S. DELL

CA-15

10-JUN-92 10:58:23

SDRC I-DEAS VI: FE_Modeling_& Analysis

Unit : IN
Display : No stored Option
Model Bin: 1-MAIN
Associated Worksheet: 3-WORKING_SET3

Database: none
View : No stored View
Task: Beam Properties
Model: 3-FE MODEL3

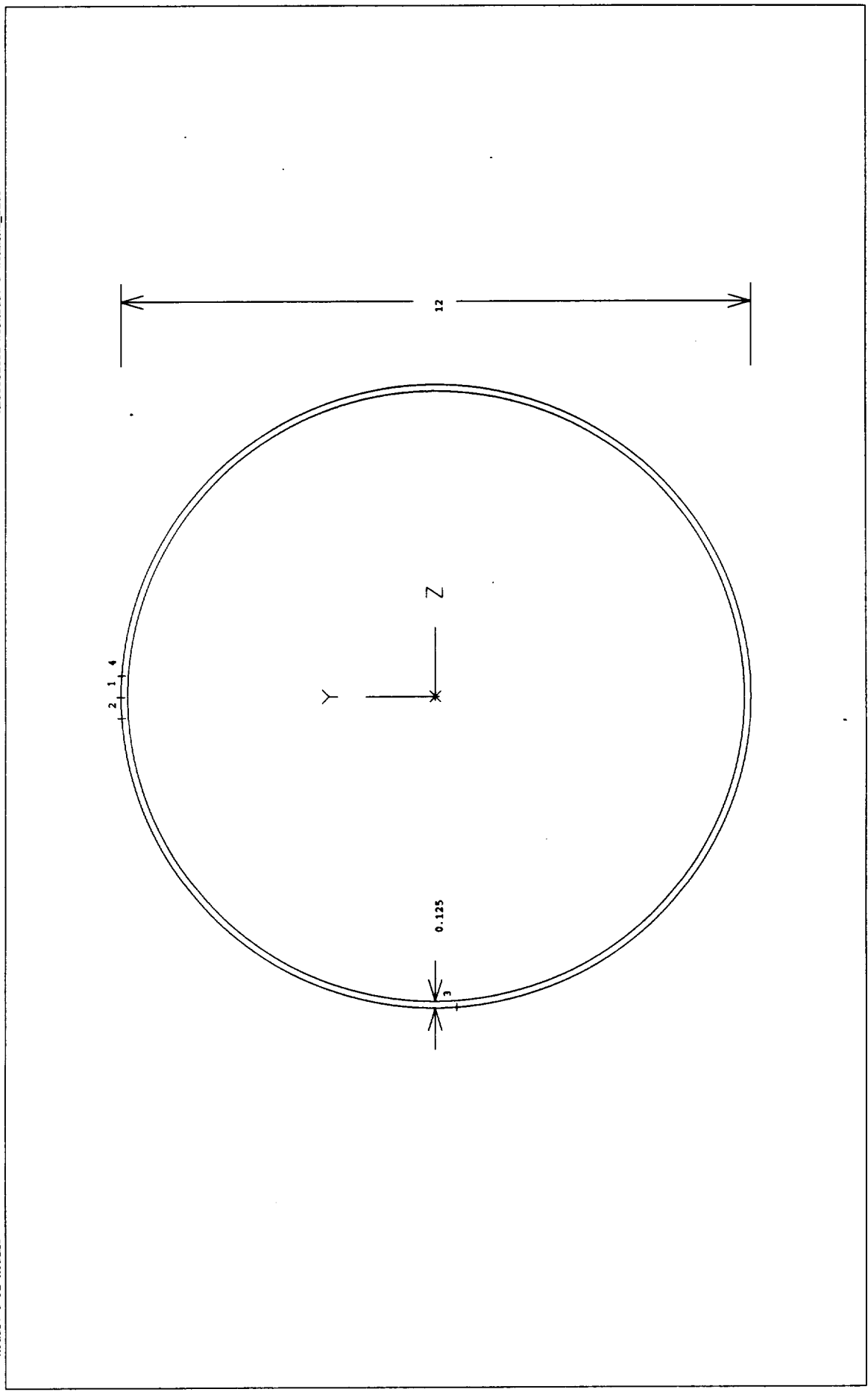

BP: JASON S. DELL

LOWER BOOM - CROSS SECTION MESH

SDRC I-DEAS VI: FE_Modeling_&Analysis

05-JUN-92 12:04:48

Database: none
View : No stored View
Task: Linear Statics
Model: 3-FE MODEL3

Units : IN
Display : No stored Option
Model Bin: 1-MAIN
Associated Worksheet: 3-WORKING_SFT3

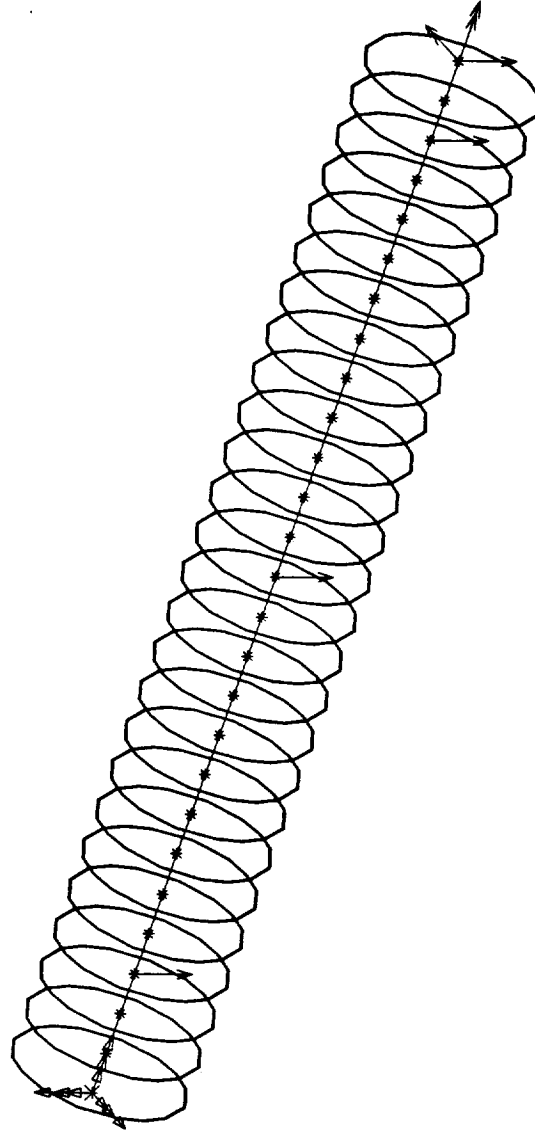

LOWER BOOM - BEAM REPRESENTATION

BY: JASON S. DELL

CA-17

SDRC I-DEAS VI: FE_Modeling_&_Analysis

05-JUN-92 12:03:37

Database: none
View : No stored View
Task: Linear Statics
Model: 3-FE MODEL3

Units : IN
Display : No stored Option
Model Bin: 1-MAIN
Associated Worksheet: 3-MORNING.SET3

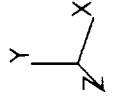
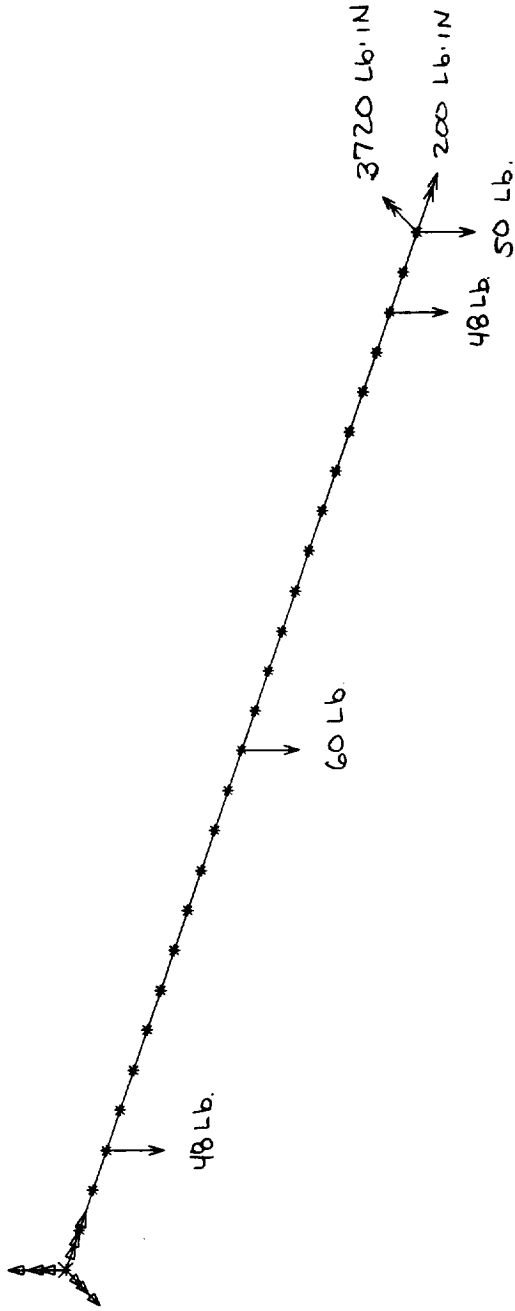

LOWER BOOM - POS 1 FORCE DIAGRAM

BY: JASON S. DELL

SDRC I-DEAS VI: FE_Modeling_&_Analysis

06-JUN-92 21:03:47

Database: none
View : No stored View
Task: Post Processing
Model: 3-FE MODEL3

Units : IN
Display : No stored Option
Model Bin: 1-MAIN
Associated Workset: 3-WORKING_SET3

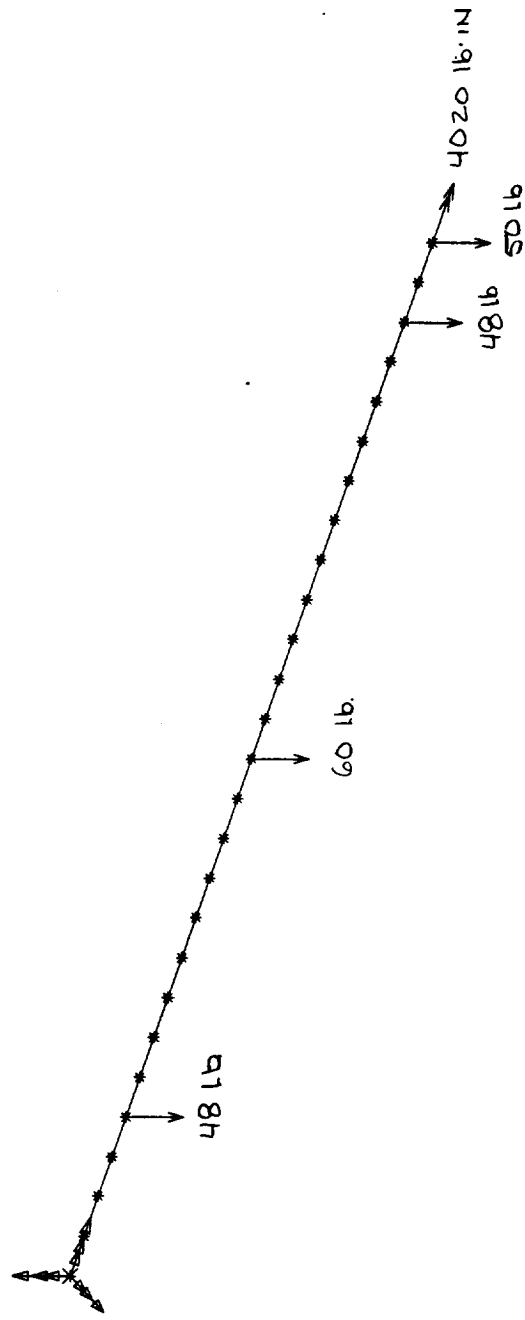

LOWER BOOM - POSITION Z - FORCE DIAGRAM

BY: JASON S. DELL

SDRC I-DEAS VI: FE_Modeling_&Analysis

Database: none

View : No stored View

Task: Post Processing

Model: 3-FE MODEL3

05-JUN-92 12:56:30

Units : IN

Display : No stored Option

Model Bin: 1-MAIN

Associated Workset: 3-WORKING_SET3

LOAD SET: 1 - LOADSET2

DISPLACEMENT - NORMAL MIN: 0.00 MAX: 0.036395

none

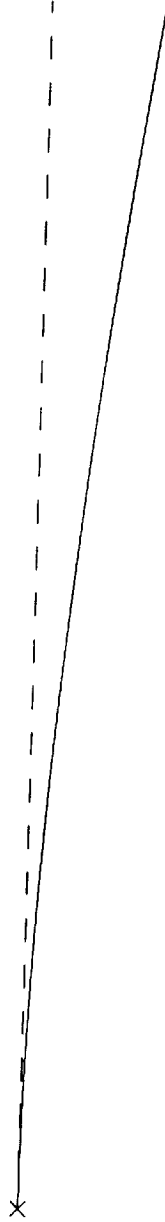

NOTE:
DRAWING IS
SCALED

LOWER BOOM - POS. 1 - DEFLECTION

BY: JASON S. DELL

SDRC I-DEAS VI: FE_Modelling_&_Analysis

06-JUN-92 21:20:35

Display : No stored Option
Model Bin: 1-MAIN
Associated Worksheet: 3-WORKING_SET3

Database: none
View : No stored View
Task: Post Processing
Model: 3-FE MODEL3

LOAD SET: 2 - POS2
DISPLACEMENT - NORMAL MIN: 0.00 MAX: 0.022772

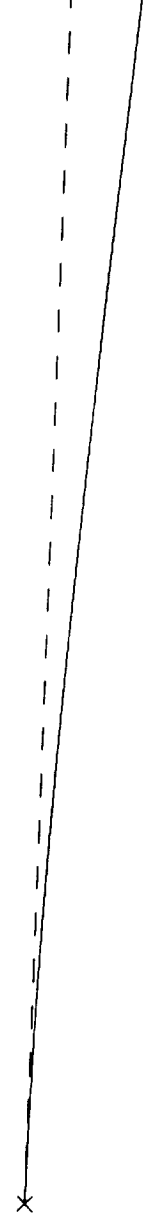

NOTE:
DRAWING IS
SCALED

LOWER BOOM - POSITION 2 - BEAM DEFLECTION

BY: JASON S. DELL

CA-71

SDRC I-DEAS VI: FE_Modeling_&Analysis

05-JUN-92 12:54:16

Database: none

View : No stored View

Task: Post Processing

Model: 3-FE MODEL3

Units : IN

Display : No stored Option

Model Bin: 1-MAIN

Associated Worksheet: 3-WORKING_SET3

LOAD SET: 1 - LOADSET3
FRAME OF REF: GLOBAL
STRESS - VON MISES MIN: 273.31 MAX: 1010.39

none

ID	Value
10	930.56
9	882.86
8	815.11
7	747.39
6	679.66
5	611.94
4	544.21
3	476.49
2	408.76
1	341.04



LOWER BOOM - POS. 1 - LONGITUDINAL BEAM STRESS

BY: JASON S. DELL

CA-27

SDRC I-DEAS VI: FE_Modeling_6_Analysis

06-JUN-92 21:22:37

Database: none
View : No stored View
Task: Post Processing
Model: 3-FE MODEL3

Units : IN
Display : No stored Option
Model Bin: 1-MAIN
Associated Worksheet: 3-WORKING_SET3

LOAD SET: 2 - POS2
FRAME OF REF: GLOBAL
STRESS - VON MISES MIN: 256.66 MAX: 802.66

none

10	733.81
9	783.38
8	653.69
7	604.66
6	594.38
5	504.72
4	453.86
3	603.41
2	353.73
1	300.2



LOWER BOOM - POSITION 2 - LONGITUDINAL BEAM STRESS

BY: JASON S. DELL

CA.22

SDRC I-DEAS VI: FE_Modeling_& Analysis

05-JUN-92 12:34:42

Database: none

View : No stored View

Units : IN
Display : No stored Option

LOAD SET: 1 - LOADSET2
 BEAM 1 AT MAX POSITION STRESS
 FX = 0.00 FY = -305.00 FZ = 0.00
 MX = 200.00 MY = 0.00 MZ = -13949.00
 BEAM X-SECTION - VON-MISES STRESS MIN: 138.78 MAX: 1010.46

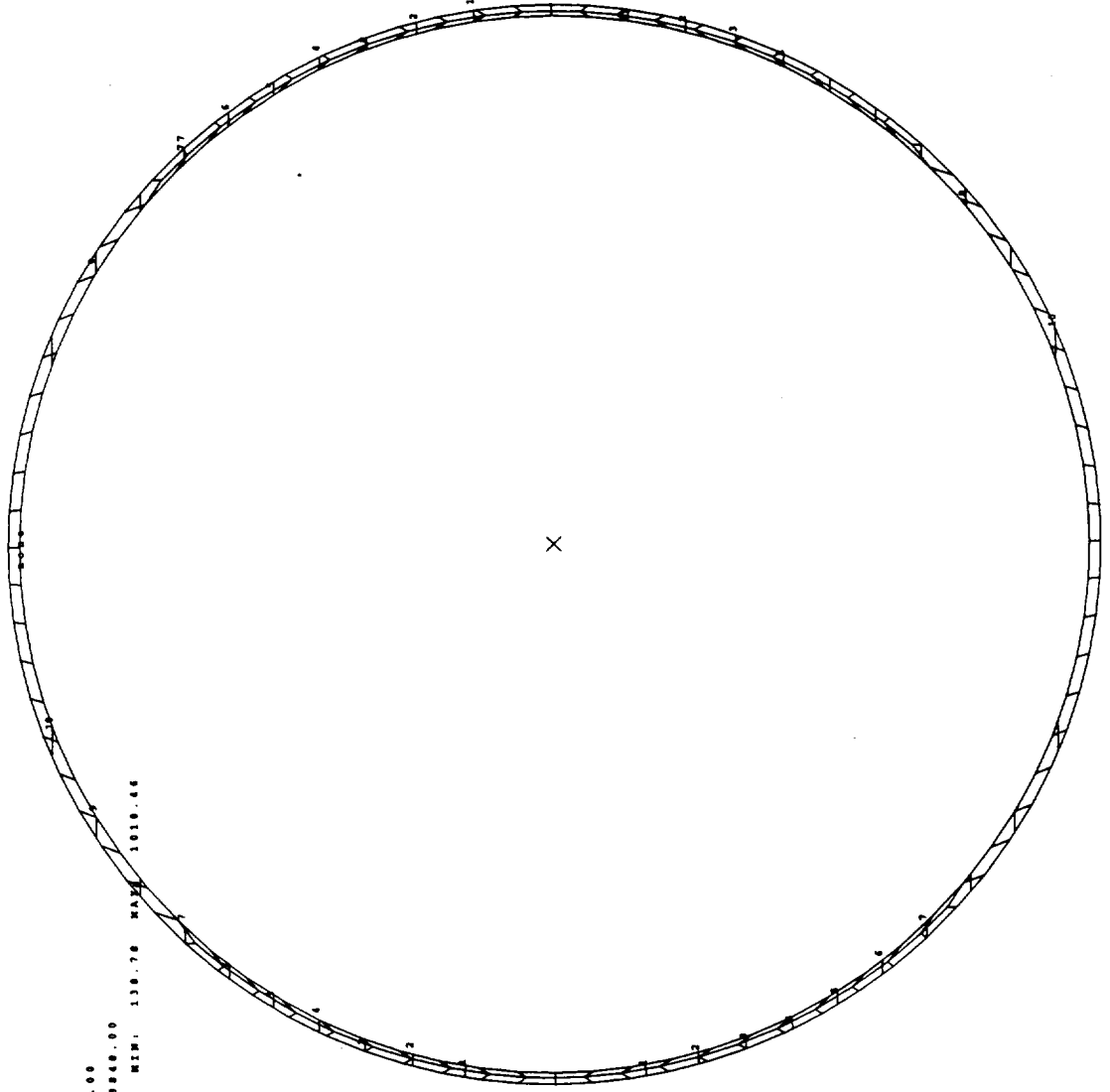

ID	Stress Value
1	210.27
2	337.37
3	376.31
4	455.76
5	535.00
6	614.24
7	693.49
8	772.73
9	851.97
10	931.22

BY: JASON S. DELL

LOWER BOOM - POS. 1 - CROSS SECTIONAL STRESS

CA 74

Database: none
View : No stored View

Units : IN
Display : No stored Option

LOAD SET: 2 - POS2
BEAM 1 AT MAX POSITION STRESS
FX = 0.00 FY = -286.00 FZ = 0.00
MX = 4820.00 MY = 0.00 MZ = -10272.00
BEAM X-SECTION - VON-MISES STRESS MIN: 54.81 MAX: 7193.13

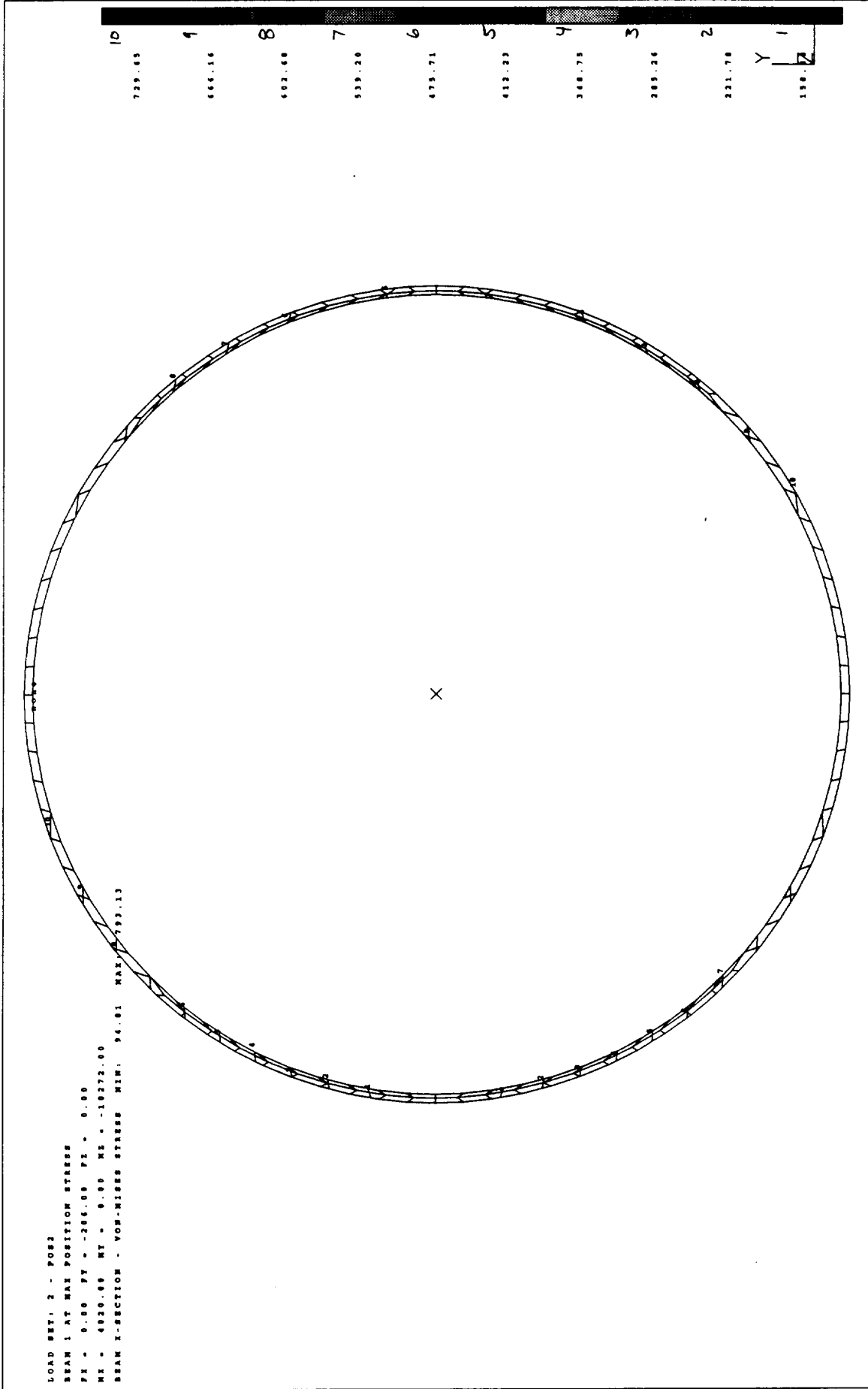

LOWER BOOM - POSITION 2 - CROSS SECTIONAL STRESS

BY: JASON S. DELL

CA-75

SDRC I-DEAS VI: FE_Modeling_& Analysis

04-JUN-92 01:15:25
Units : IN
Display : No stored Option
Model Bin: 1-MAIN
Associated Worksheet: 1-WORKING_SET1

Database: none
View : No stored View
Task: Beam Properties
Model: 3-FE MODEL3

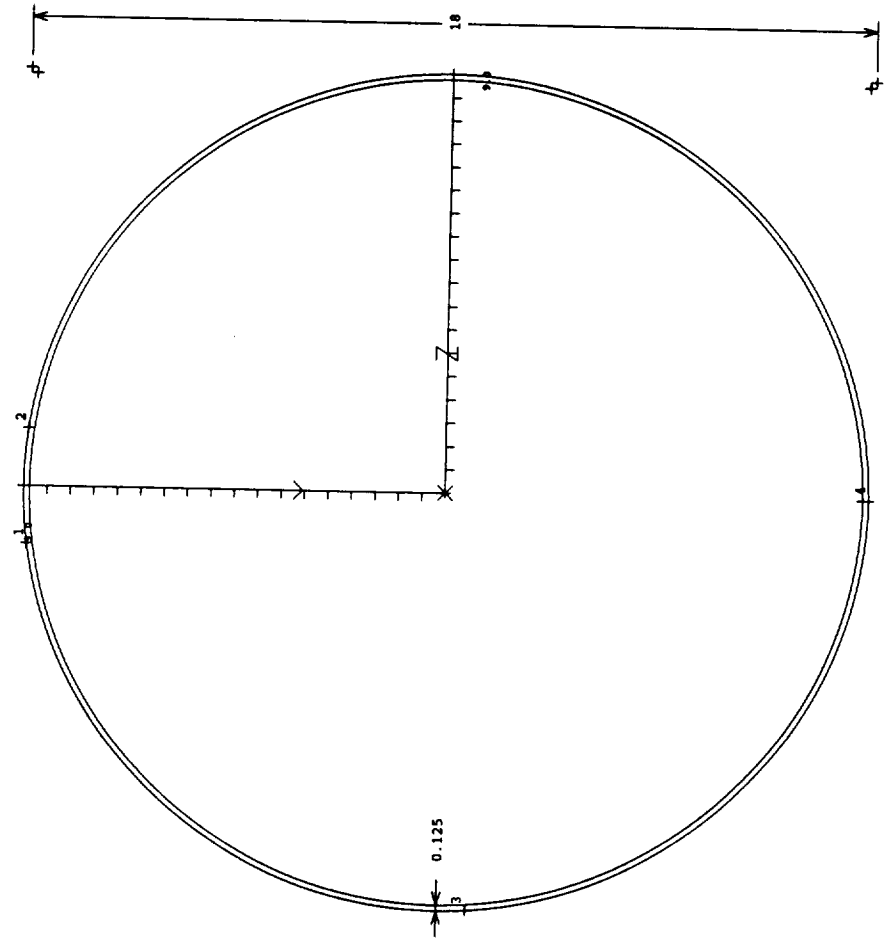

CHASSIS- CROSS SECTION MESH

BY: JASON S. DELL

SDRC I-DEAS VI: FE_Modeling_&_Analysis

Database: none
View : No stored View
Task: Boundary Conditions
Model: 3-FE MODEL3

06-JUN-92

20:51:41

Units : IN
Display : No stored Option
Model Bin: 1-MAIN
Associated Worksheet: 1-WORKING_SEF1

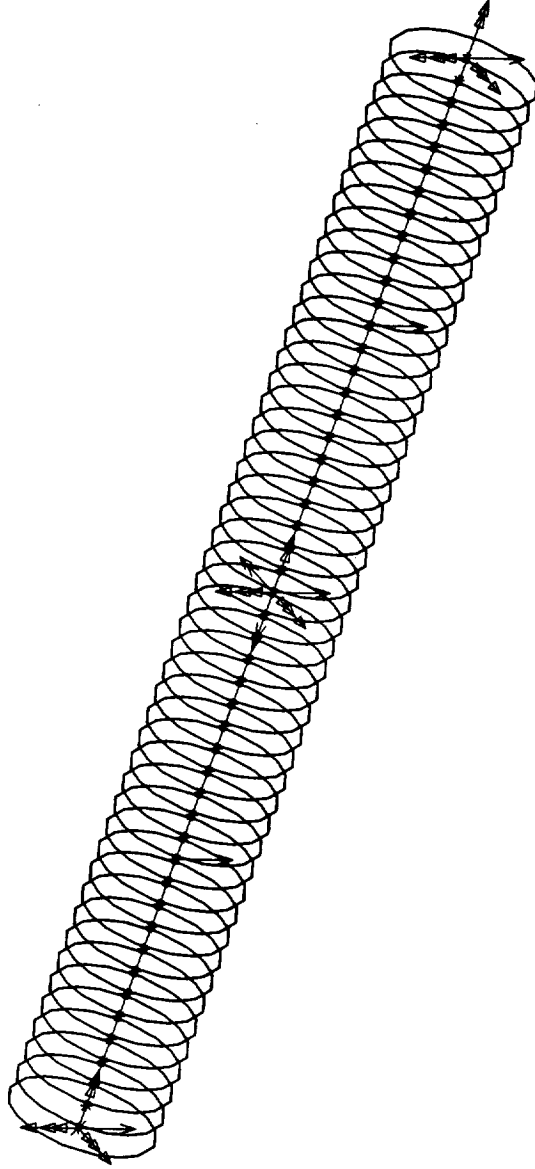

CHASSIS - BEAM REPRESENTATION

BY: JASON S. DELL

SDRC I-DEAS VI: FE_Modeling_&Analysis

Database: none
View : No stored View

Task: Boundary Conditions
Model: 4-BEAM18

10-JUN-92

13:05:33

Units : IN

Display : No stored Option

Model Bin: 1-MAIN

Associated Worksheet: 8-WORKING_SET8

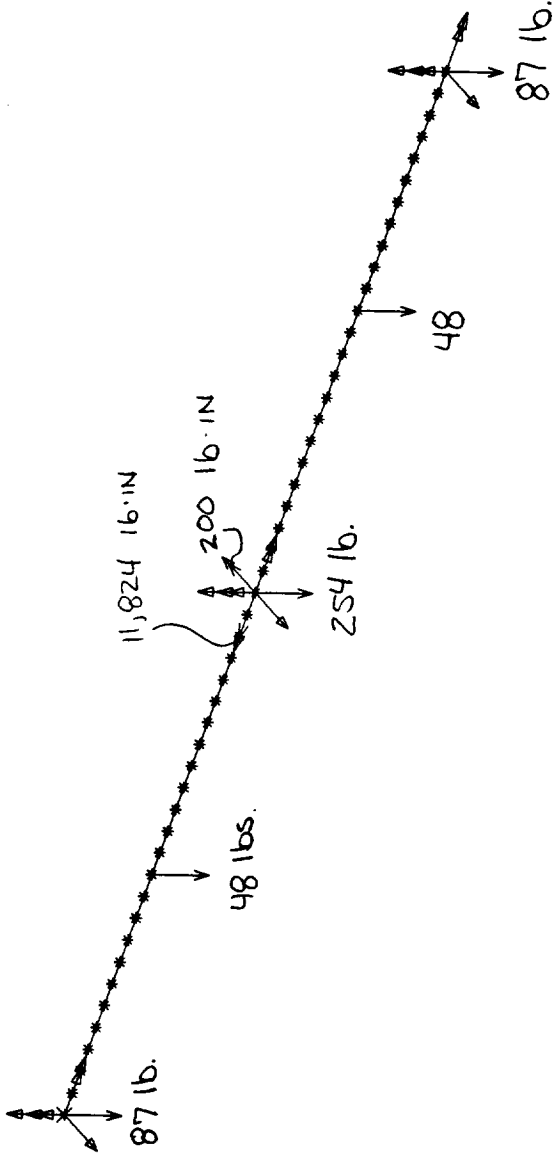

CHASSIS - POSITION 1 - FORCE DIAGRAM

CA-28

BY: JASON S. DELL

SDRC I-DEAS VI: FE_Modeling_4_Analysis
10-JUN-92 11:35:32
Units: IN
Display: No stored Option
Model Bin: 1-MAIN
Associated Worksheet: 8-WORKING_SET8

Database: none
View: No stored View
Task: Boundary Conditions
Model: 4-BEAM18

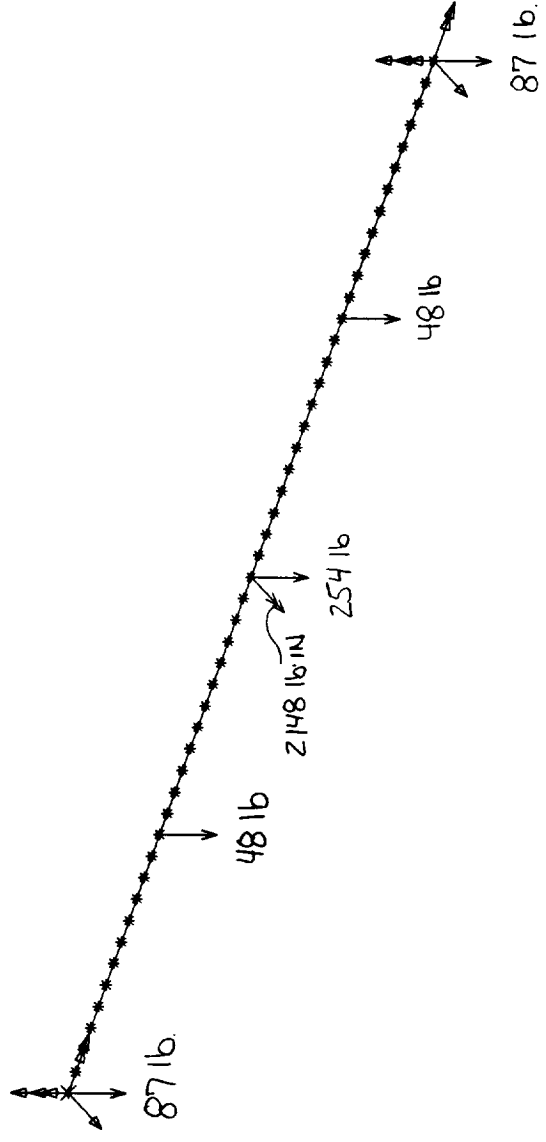

CHASSIS - POSITION 3 - FORCE DIAGRAM

BY: JASON S. DELL

CA-29

SDRC I-DEAS VI: FE_Modeling_&_Analysis

Database: none

View : No stored View

Task: Post Processing

Model: 4-BEAM18

10-JUN-92

12:50:54

Units : IN

Display : No stored Option

Model Bin: 1-MAIN

Associated Worksheet: 8-WORKING_SET8

LOAD SET: 2 - REDO
DISPLACEMENT - NORMAL MIN: 0.00 MAX: 0.0000139



NOTE:
DIAGRAM IS
SCALED

CHASSIS- POSITION 1 - BEAM DEFLECTION

BY: JASON S. DELL

SDRC I-DEAS VI: FE_Modeling_&_Analysis

06-JUN-92 21:45:53

Database: none
View : No stored View
Task: Post Processing
Model: 3-FE MODEL3
Associated Worksheet: 1-WORKING_SET1
Display: No stored Option
Model Bin: 1-MAIN
Units : IN

LOAD SET: 3 - POS3
DISPLACEMENT - NORMAL MIN. 0.00 MAX. 0.007833

none

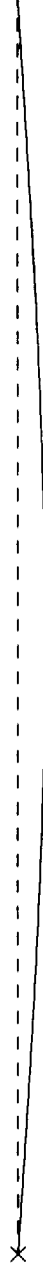

NOTE:
DIAGRAM IS
SCALED

CHASSIS - POSITION 3 - BEAM DEFLECTION

BY: JASON S. DELL

SDRC I-DEAS VI: FE_Modeling_&Analysis

10-JUN-92 12:47:56
Units : IN

Database: none
View : No stored View
Task: Post Processing
Model: 4-BEAM18

Display : No stored Option
Model Bin: 1-MAIN
Associated Workset: 8-WORKING_SET8

LOAD SET: 2 - REDO
FRAME OF REF: GLOBAL
STRESS - VON MISES MIN: 7.77 MAX: 23.26

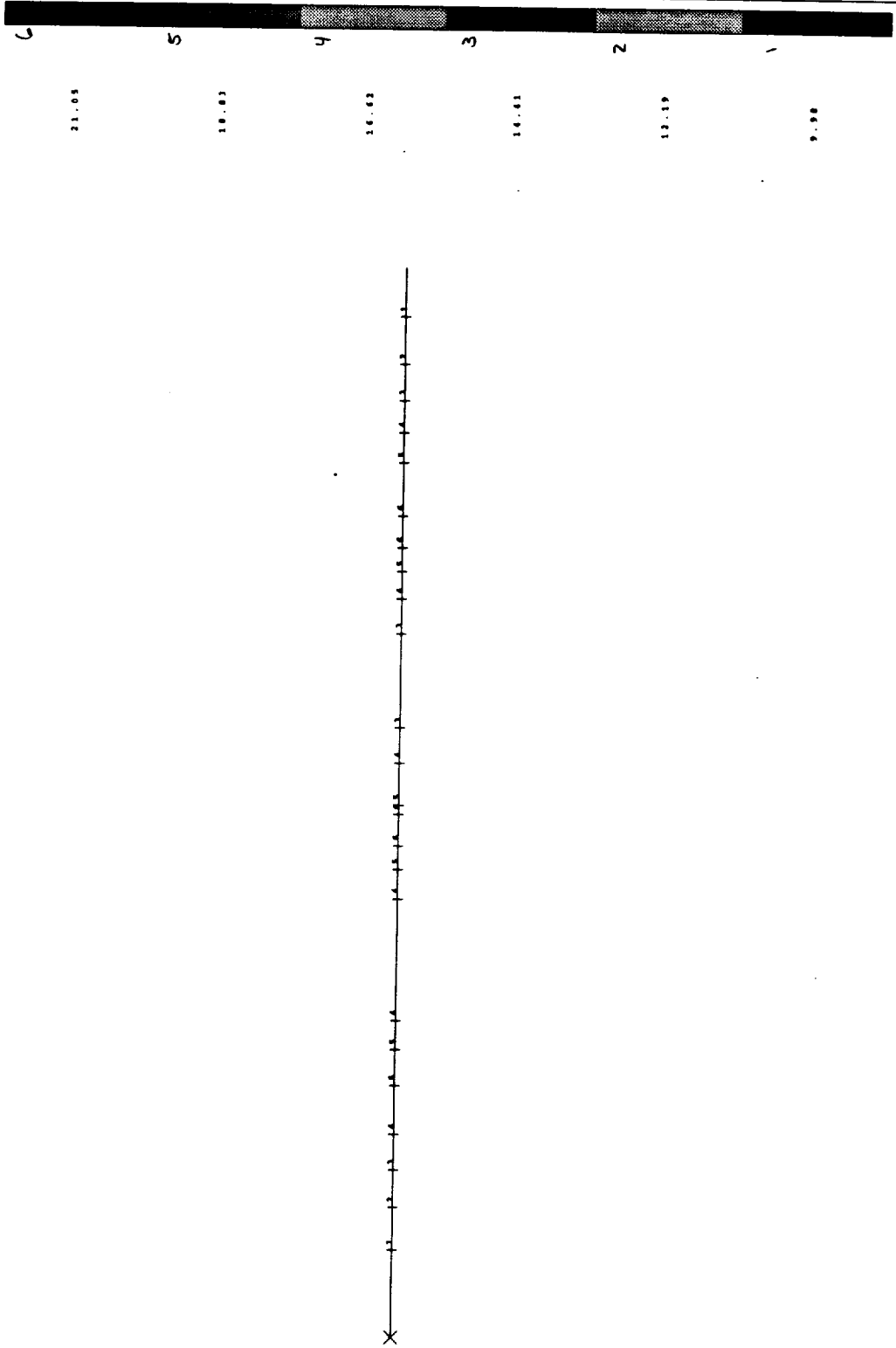

23.26

18.00

14.00

10.00

6.00

2.00

CHASSIS - POSITION 1 - LONGITUDINAL BEAM STRESS

SDRC I-DEAS VI: FE_Modeling_&_Analysis

Database: none
View : No stored View

Task: Post Processing
Model: 3-FE MODEL3

06-JUN-92

21:53:27

Units : IN

Display : No stored Option
Model Bin: 1-MAIN

Associated Worksheet: 1-WORKING_SET1

LOAD SET: 3 - POST
FRAME OF REF: GLOBAL
STRESS - VON MISES MIN. 74.64 MAX. 375.66

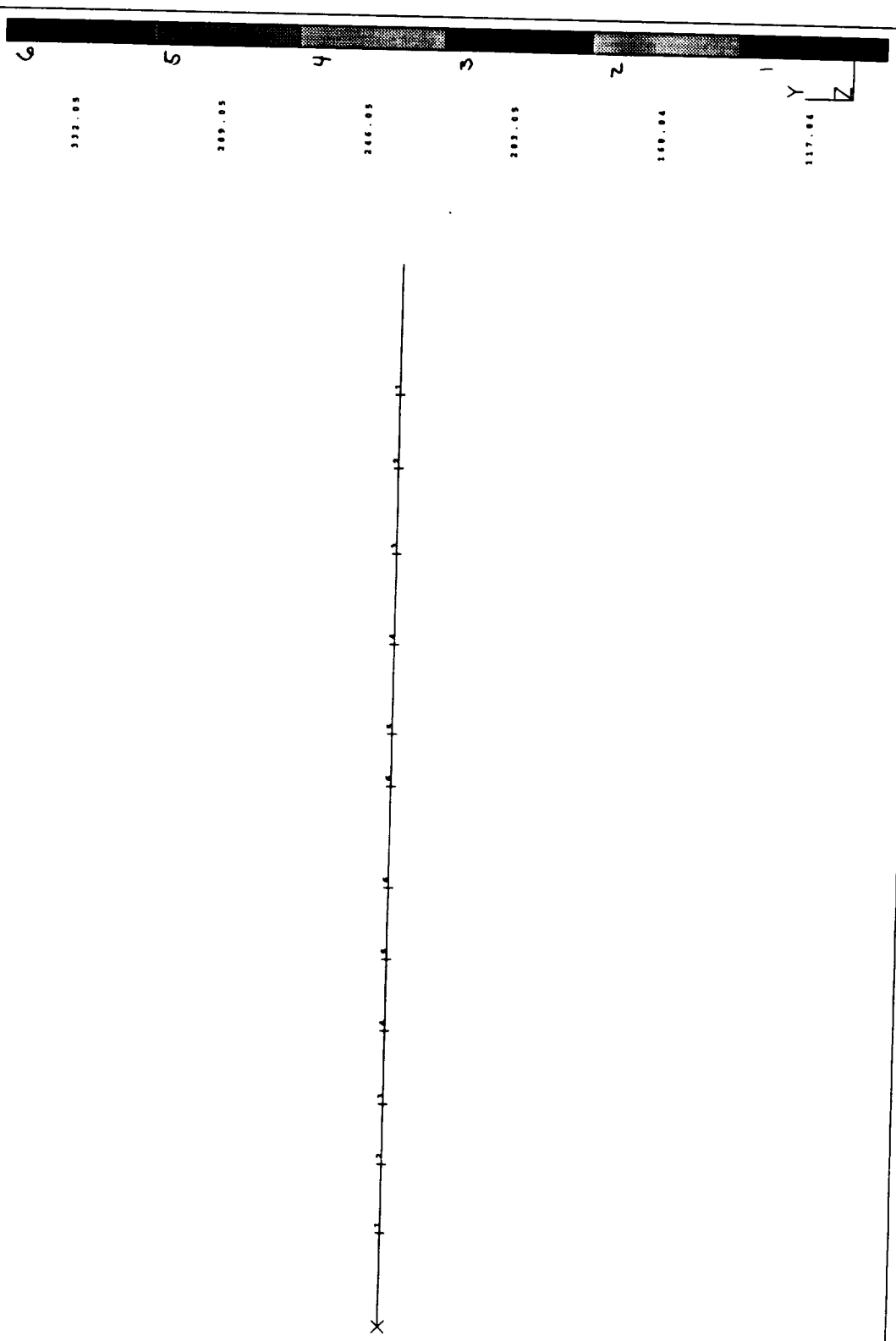

CHASSIS - POSITION 3 - LONGITUDINAL BEAM STRESS

BY: JASON S. DELL

CA-22

SDRC I-DEAS VI: FE_Modeling_&_Analysis

Database: none
View : No stored View

10-JUN-92

13:03:41

Unit: IN
Display: No stored Option

LOAD SET: 2 - REDO
BEAM J8 AT MAX POSITION STRESS
FX = 0.00 FY = 19.57 FZ = 0.00
MX = 0.00 MY = 0.00 MZ = 643.94
BEAM X-SECTION : VON-MISES STRESS MIN: 9.55 MAX: 10.71

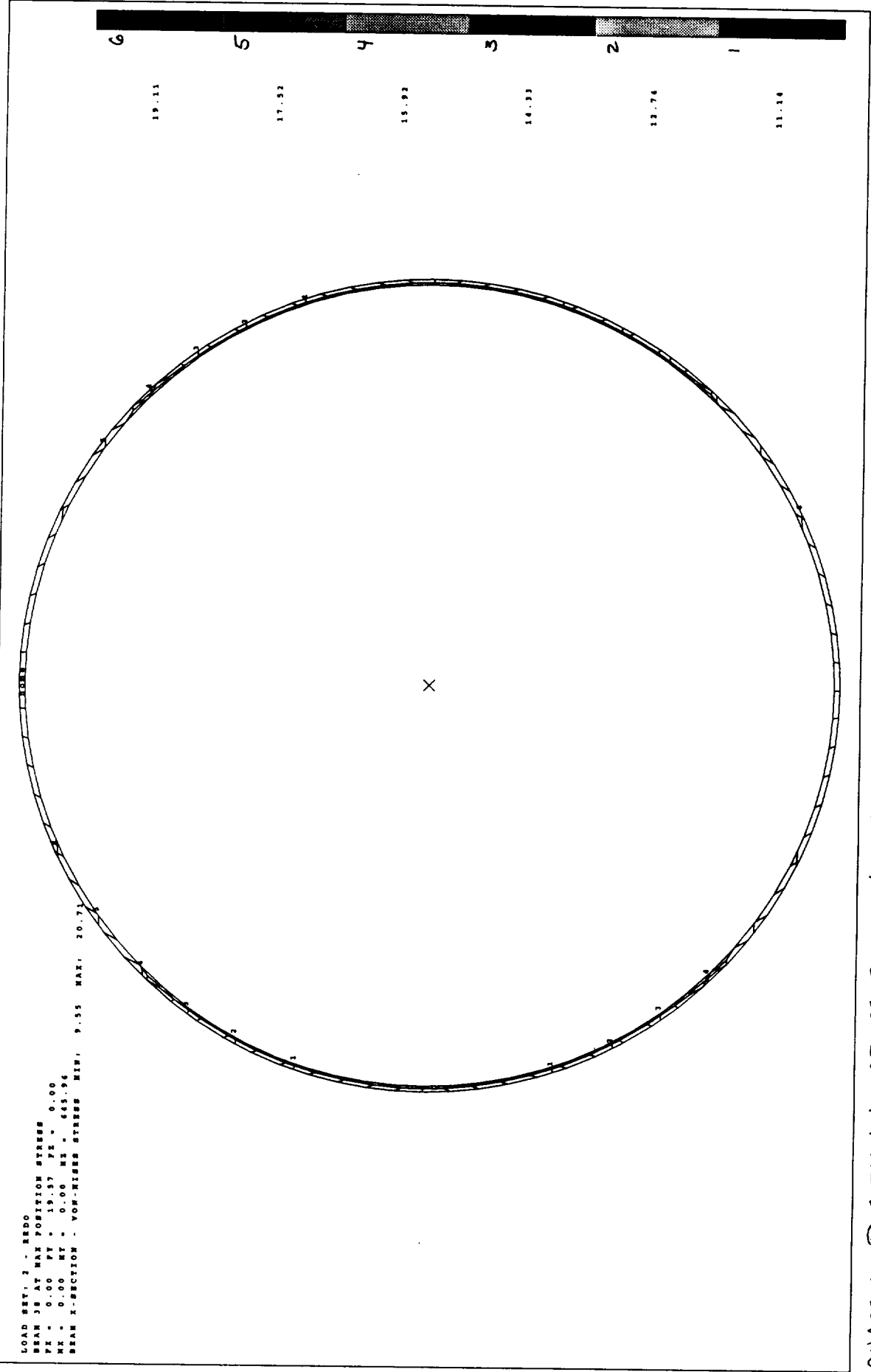

CHASSIS - POSITION 1 - CROSS SECTIONAL STRESS

BY: JASON S. DELL

CA-34

06-JUN-92 22:08:47
 Units : IN
 Display : No stored Option

SDRC I-DEAS VI: FE_Modeling_&Analysis

Database: none
 View : No stored View

LOAD SET: 3 - (POST)
 BEAK 25 AT MAX POSITION STRESS
 FX = 0.00 FY = 112.00 FZ = 0.00
 MX = 0.00 MY = 0.00 MZ = 9790.00
 BEAM 1-SECTION - VON-MISES STRESS MIN: 54.69 MAX: 312.06

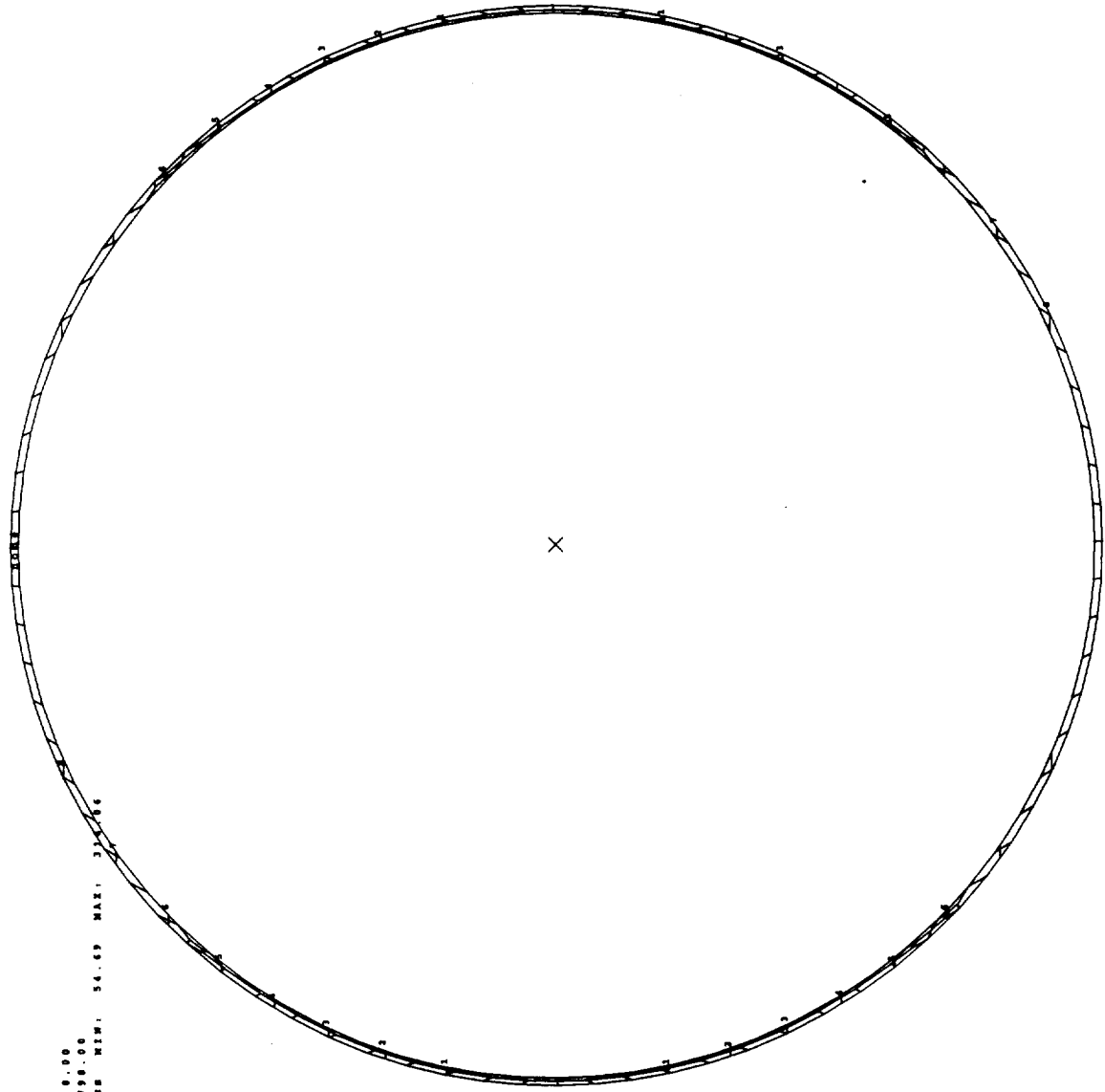

CHASSIS - POSITION 3 - CROSS SECTIONAL STRESS

BY: JASON S. DELL

CA-35

X. SUMMARY

X.1 ACHIEVEMENTS

Group One has accomplished many tasks in the design and optimization of the lunar enabler chassis and boom components. In general, material was chosen from which exact dimensions were determined. Specifically, the end section exhibits a modular design with removal of bulkheads and design of an extension for the engine. The internal structure was also removed from the center section. The V-clamp design is capable of attaching to both the articulation bearing and chassis skin. This design accomplishes the task of preventing axial rotation of adjoining sections while providing a necessary interface. The upper boom exhibits a minimized weight with a maximum loading capacity of 29 lb. and a factor of safety of 1.5. The boom can be readily ordered from a flagpole manufacturer and is readily compatible with the elbows and articulation joints. The weight of the lower boom was also minimized, yet still supported the entire boom assembly with the applied load at the tip of the upper boom.

X.2 SUGGESTIONS

It would be desirable to either increase wheel diameter or reduce articulation joint length. Doing so would prevent "bottoming out" of the articulation joint when rotated to a 30-degree angle. In addition, the engine should be placed toward the front of the vehicle so that the vehicle's center of gravity will approach the center of the chassis structure. Again, this would prevent the vehicle from dragging against the lunar surface while in transit. Finally, areas of high stress should be riveted or otherwise joined rather than welded. The yield strength of aluminum

6061-T0 is 8 kpsi, compared to 35 kpsi for aluminum 6061-T6. The factor of safety of the boom could be increased by joining, rather than welding, connection joints.

APPENDIX XI.1
FINAL DRAWINGS

Drawing NumberDescription

SM-1	Vehicle position 1 (shaded)
SM-2	Vehicle position 1 (wire)
SM-3	Vehicle position 2 (shaded)
SM-4	Vehicle position 3 (shaded)
SM-5	Vehicle position 3 (shaded, view 2)
SM-6	Vehicle position 4 (shaded)
SM-7	Boom (shaded)
SM-8	Boom (wire)
SM-9	Chassis (shaded)
SM-10	Chassis (wire)
SM-11	90° elbow (shaded)
SM-12	45° elbow assembly (shaded)
AS-1	Enabler Assembly
CH-1	Face plate
CH-2	Front end section
CH-3	Rear end section
CH-4	End section quarter panel
CH-5	Center section
CH-6	Center section quarter panel
CH-7	Chassis/boom interface cylinder
VC-1	Clamp and bearing assembly
VC-2	Clamp assembly
VC-3	Female V-clamp cross section
VC-4	Male V-clamp cross section
VC-5	Chassis female V-clamp support ring
VC-6	Boom female V-clamp support ring
VC-7	Chassis male V-clamp support ring
VC-8	Boom male V-clamp support ring
BM-1	Upper boom dimensions
BM-2	Lower boom assembly
BM-3	Lower extension
BM-4	Lower elbow
BM-5	Upper elbow

SDRC I-DEAS V1: Solid_Modeling

03-JUN-92 20:58:09

Units : IN
Display : No stored option

Min. I-HALT
Update Level: Full

Database: none
View : No stored View
Task: Object
Object: I-MODEL. (VEHICLE. B111)

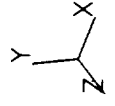
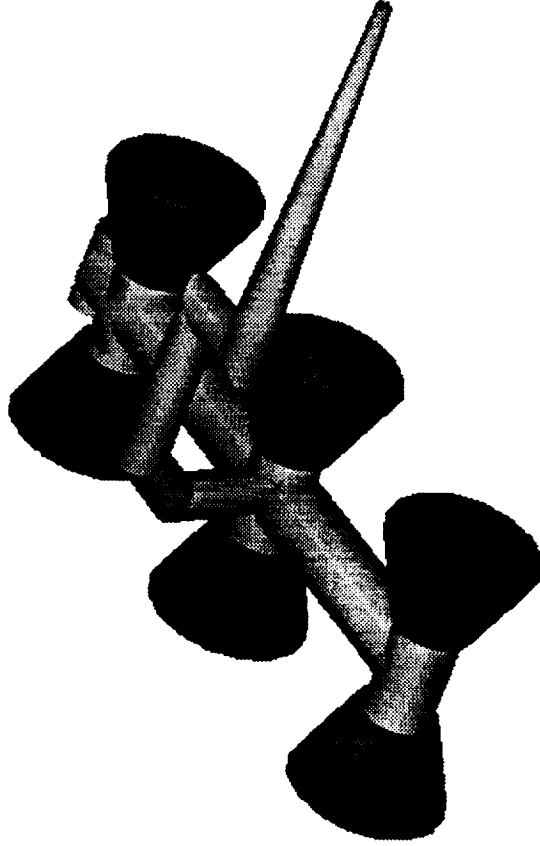

DRAWING NO. SM-1

BY: JASON S. DELL

SDRC I-DEAS VI: Solid_Modeling

03-JUN-92 20:55:12

Unit: IN

Display: No stored option

Bin: I-WORK1

Update Level: Full

Database: none

View: No stored View

Task: Object

Object: I-WORK1, (VEHICLE, Bin1)

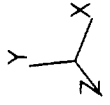
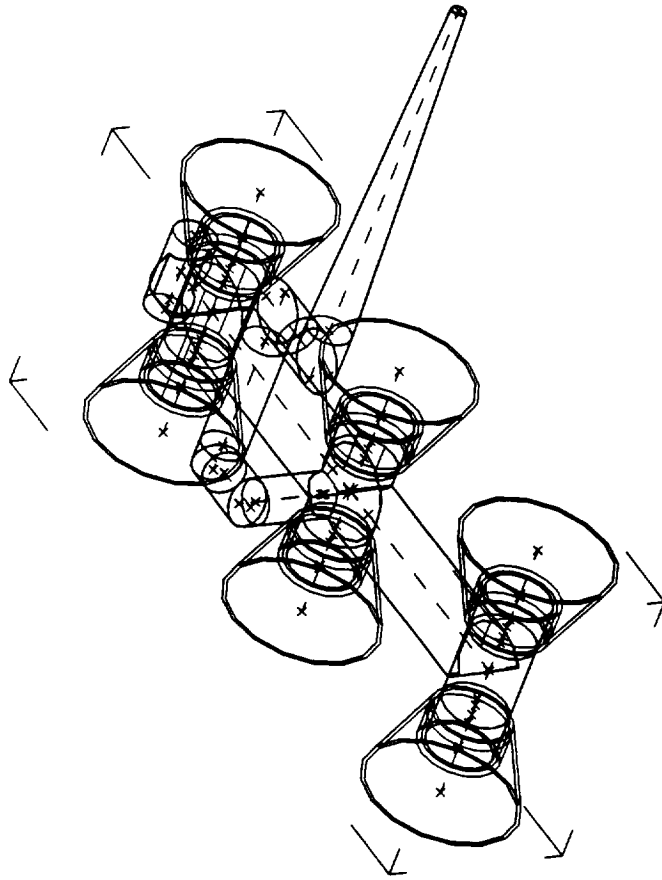

DRAWING NO. SM-2

BY JASON S. DELL

SDRC I-DEAS VI: Solid_Modeling

Database: none
View: No stored View
Task: Object
Object: I-WORK1, (I-WORK1, B1.A1) (Mod)

04-JUN-92 12:55:43

Units: IN
Display: No stored Option

Bin: I-WORK1
Update Level: Full

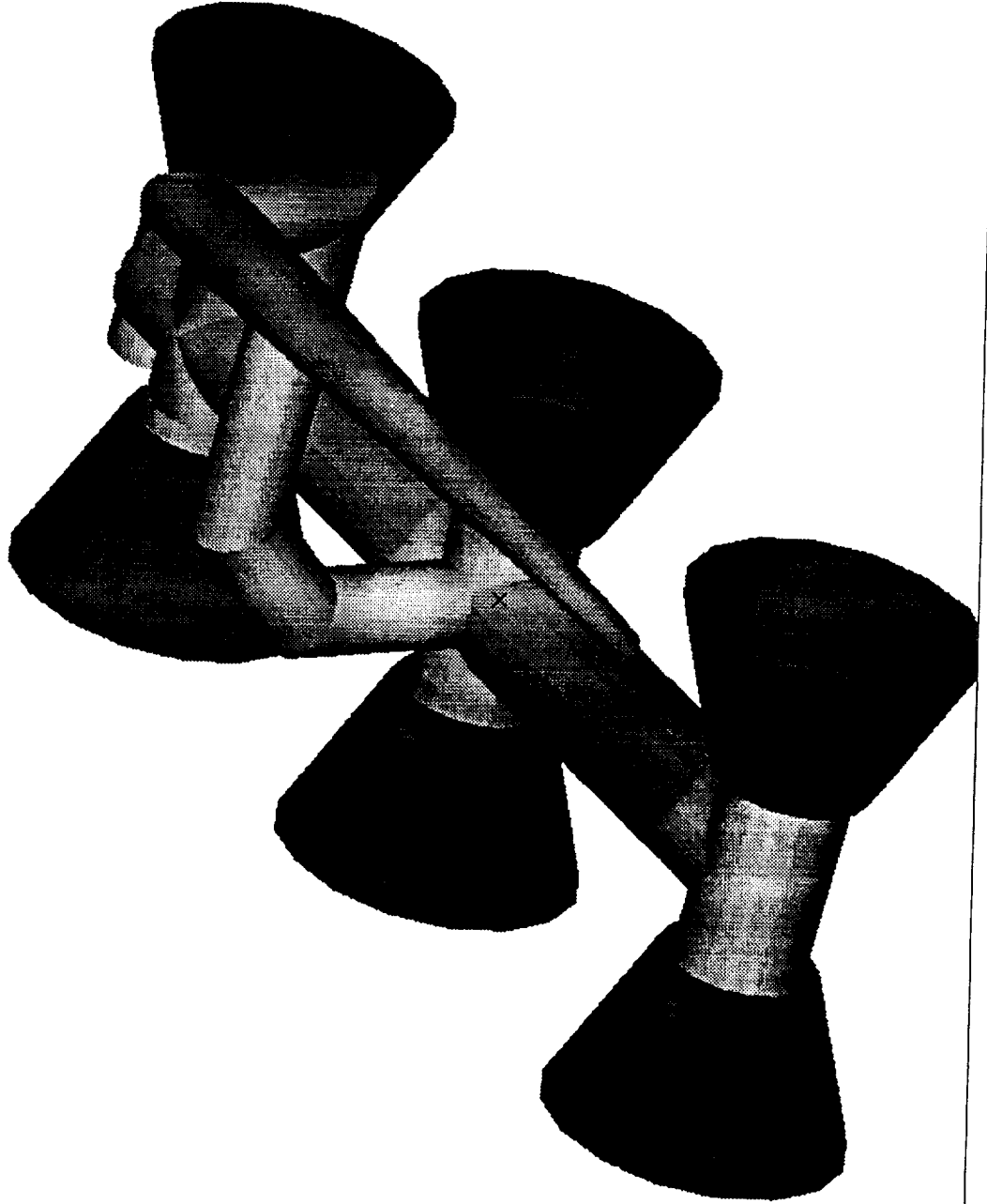

DRAWING NO. SM-3

BY: JASON S. DELL

SDRC I-DEAS VI: Solid_Modeling

Database: none
View : No stored View
Task: Object
Object: 2-MODEL (PR. Bin) (Mod)

04-JUN-92 13:11:47

Display : No stored Option
Units : IN

Bin: 1-MODEL
Update Level: Full

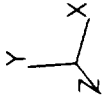
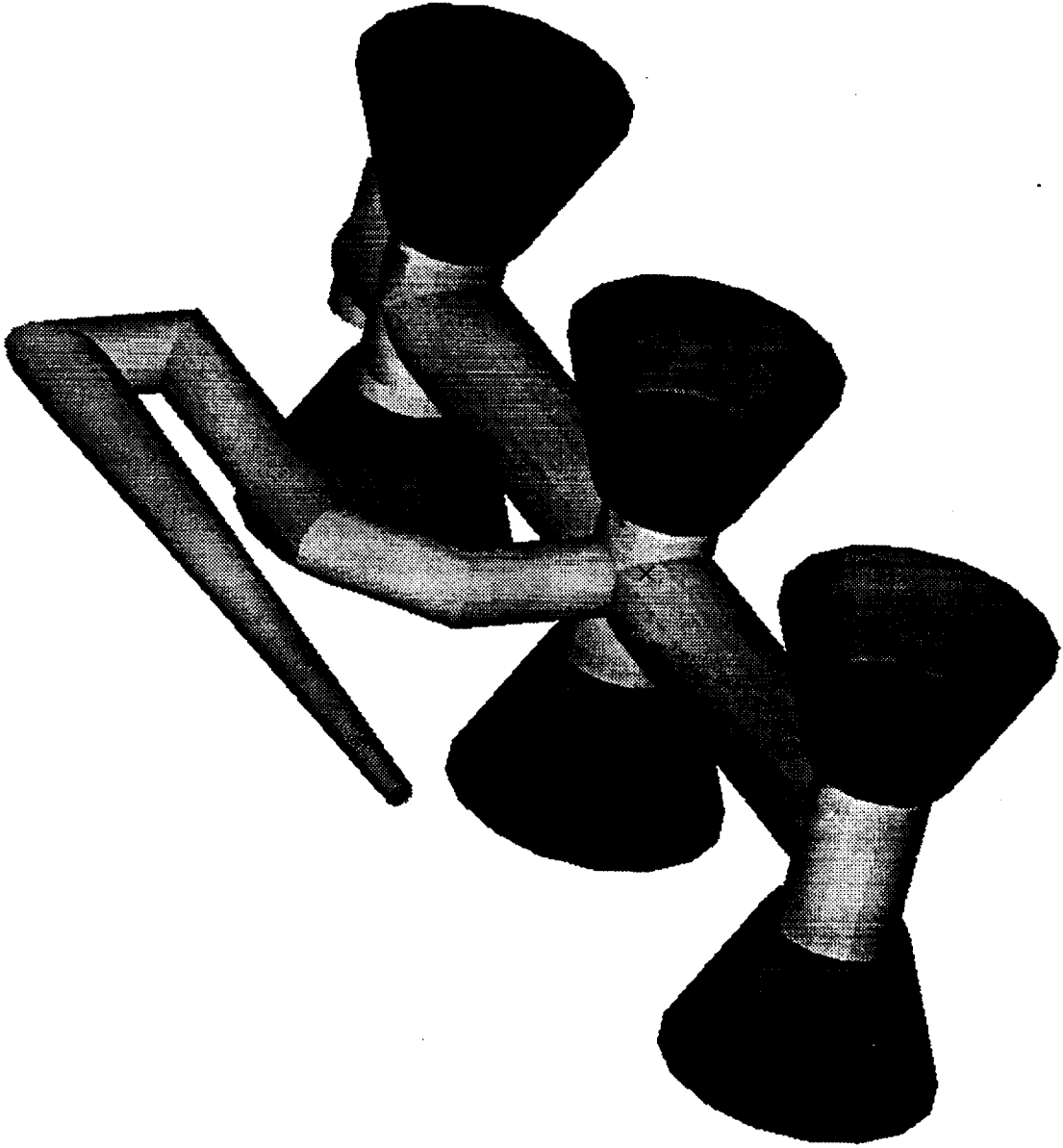

DRAWING NO. SM-4

BY: JASON S. DELL

SDRC I-DEAS VI: Solid_Modeling

04-JUN-92 13:05:40
Units : IN
Display : No stored Option
Bin: 1-MIN
Update Level: Full

Database: none
View : No stored View
Task: Object
Object: 2-MODE2, (M, Bial) (mod)

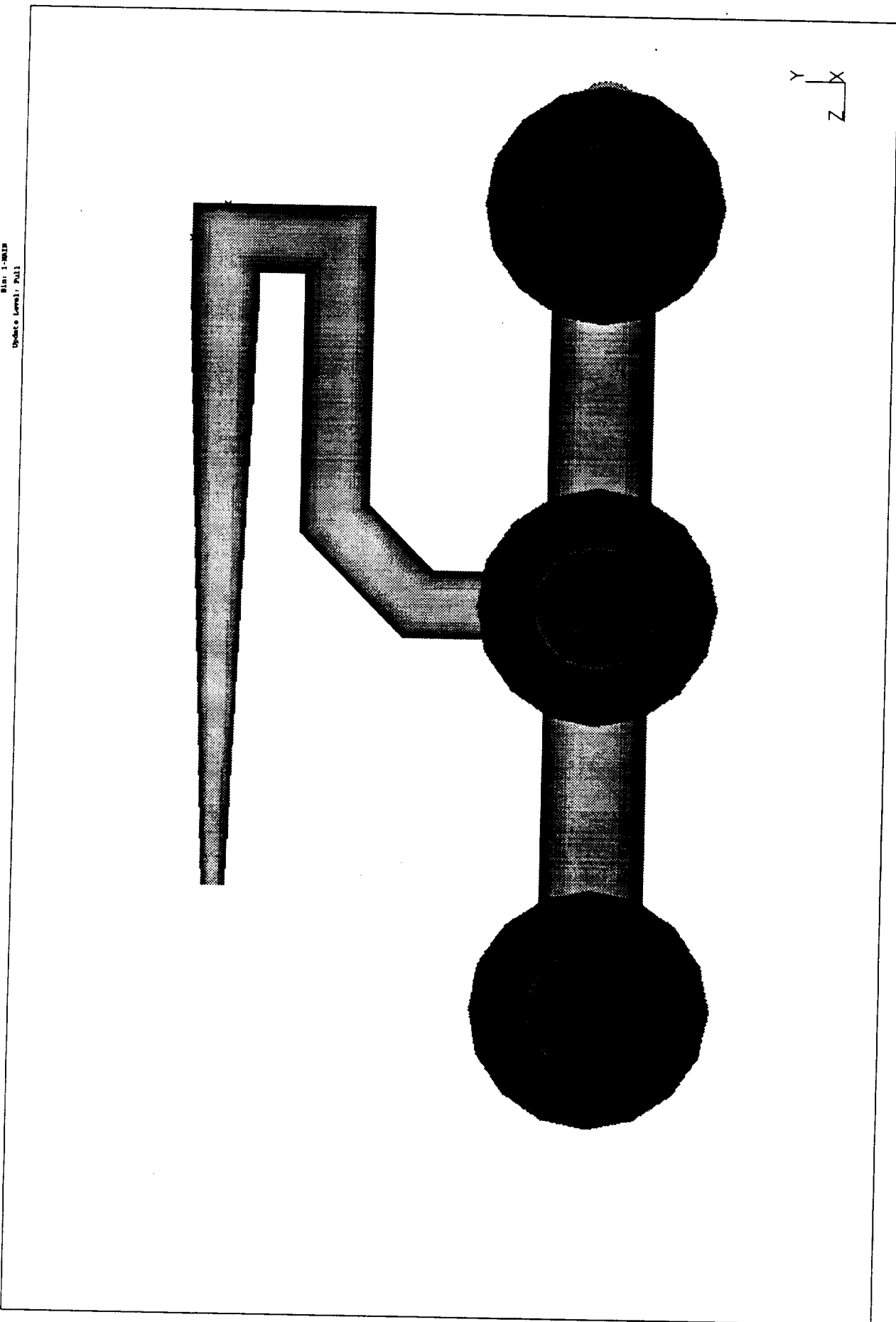

DRAWING NO. SM-5

BY: JASON S. DELL

SDRC I-DEAS VI: Solid_Modeling

Date: none
View : No stored View
Task: Object
Object: 2-BONE2, (RE, B1A1) (MOD)

04-JUN-92 13:19:07

Units : IN
Display : No stored Option

Bin: 1-MAIN
Update Level: Full

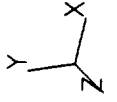
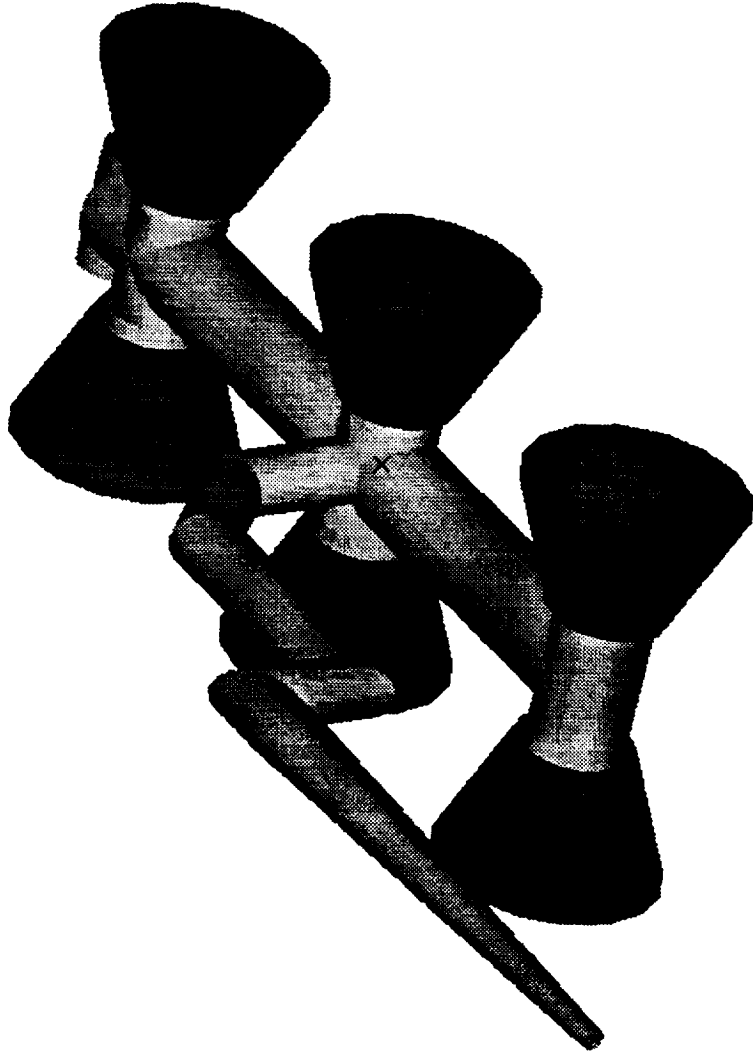

DRAWING No. SM-6

BY: JASON S. DELL

SDRC I-DEAS VI: Solid_Modeling

03-JUN-92 21:12:12

Units : IN
Display : No stored Option

Database: none
View : No stored View
Task: OBJECT
Object: I-DEAS1, (TOTAL, B1a) (Mod)

Bin: I-DEAS
Update Level: Full

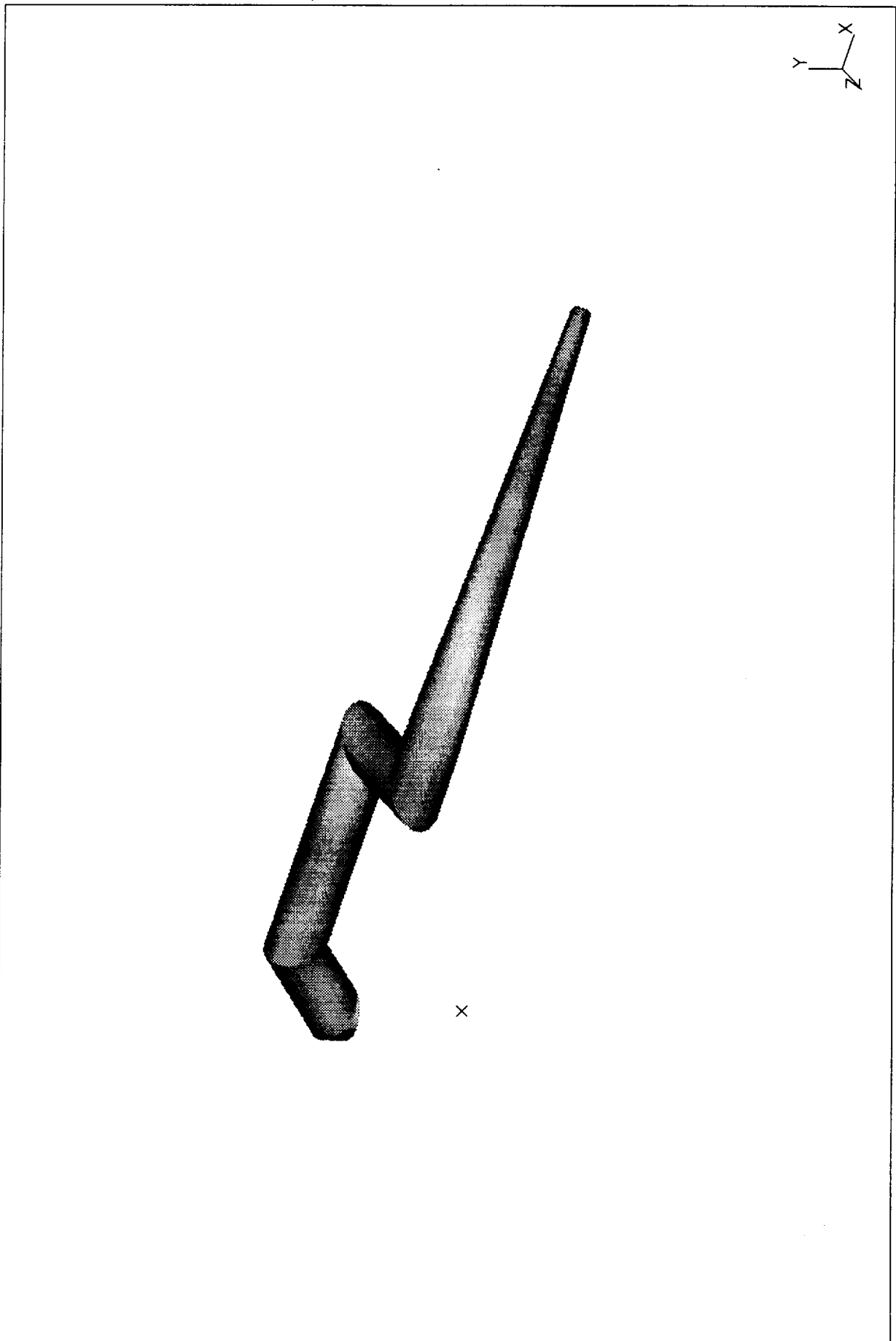

DRAWING NO. SM-7

BY: JASON S. DELL

SDRC I-DEAS VI: Solid_Modeling

Database: none
View: No stored View
Task: Object
Object: I-MODEL (TOTAL, B1A1) (Mod)

03-JUN-92 21:10:30

Units: IN

Display: No stored Option

Bin: I-MODEL

Update Level: PULL

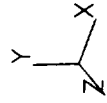
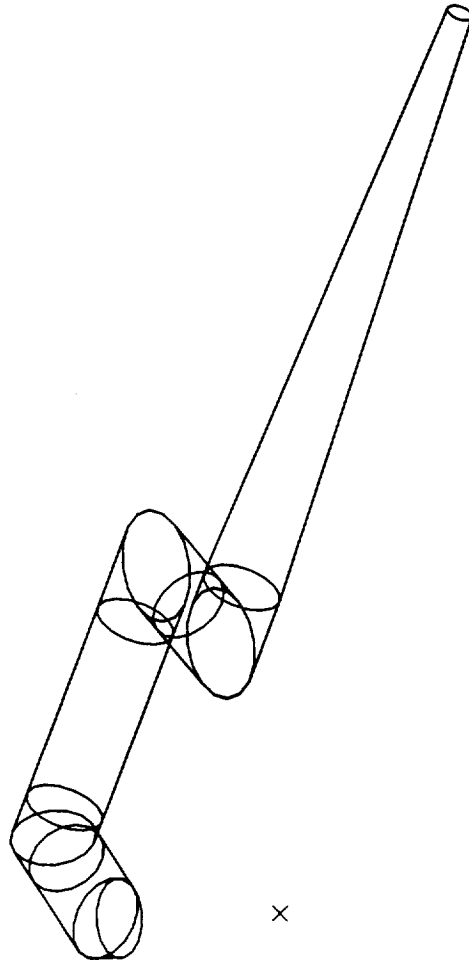

DRAWING No. SM-8

BY: JASON S. DELL

SDRC I-DEAS VI: Solid_Modeling

Database: none
View : No stored View
Task: Object
Object: 1-WORK1. (PUNCTURE_Blat)

03-JUN-92 21:17:47

Units : IN
Display : No stored Option

Bin. 1-WORK1
Update Level: Full

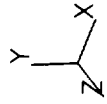
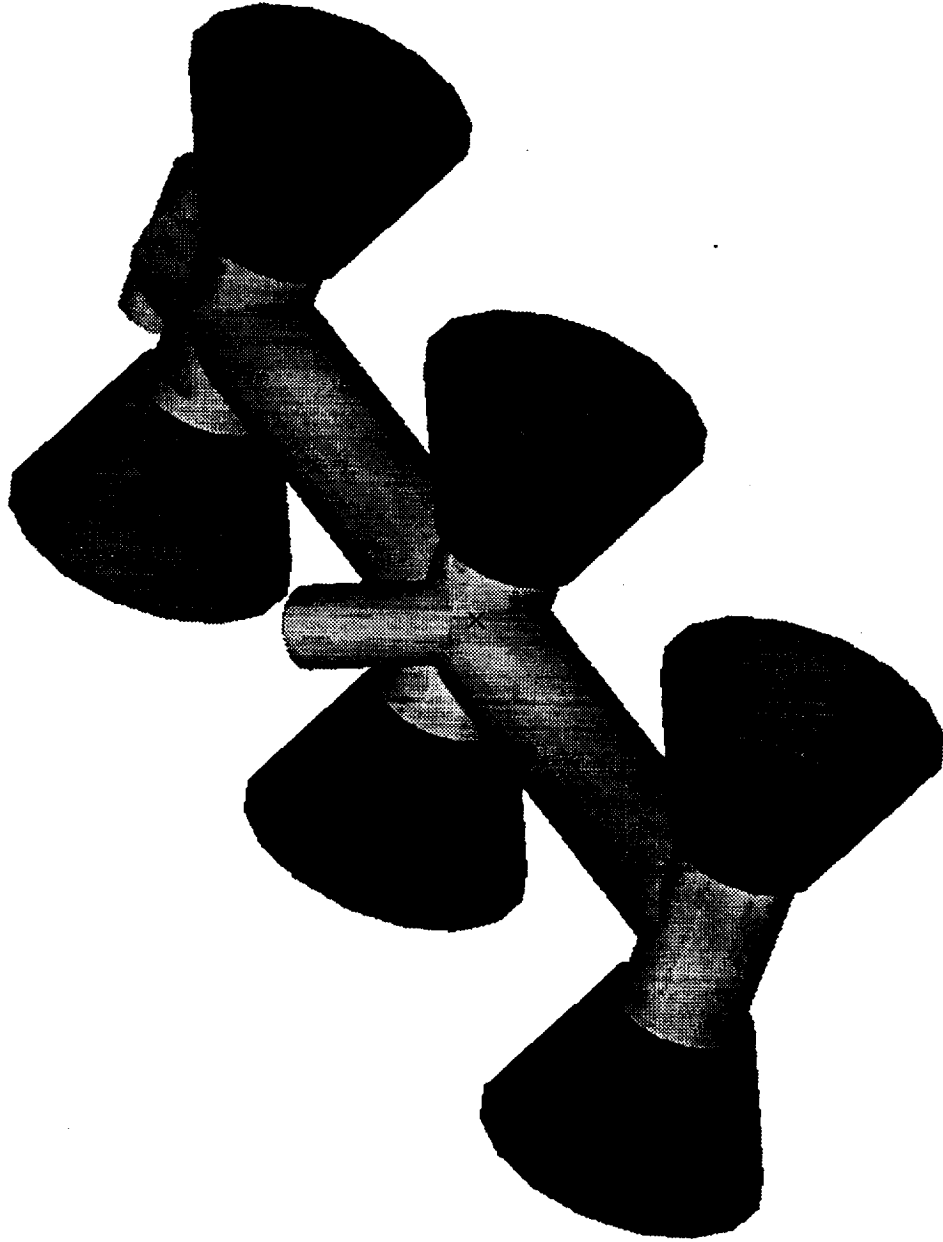

DRAWING No. SM-9

BY: JASON S. DELL

SDRC I-DEAS VI: Solid_Modeling

03-JUN-92 21:14:52

Units : IN
Display : No stored Option

Database: none
View : No stored View
Task: Object
Object: I-MORE1, (VEHICLE, Bim)

Bin: I-MORE1
Update Level: Full

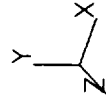
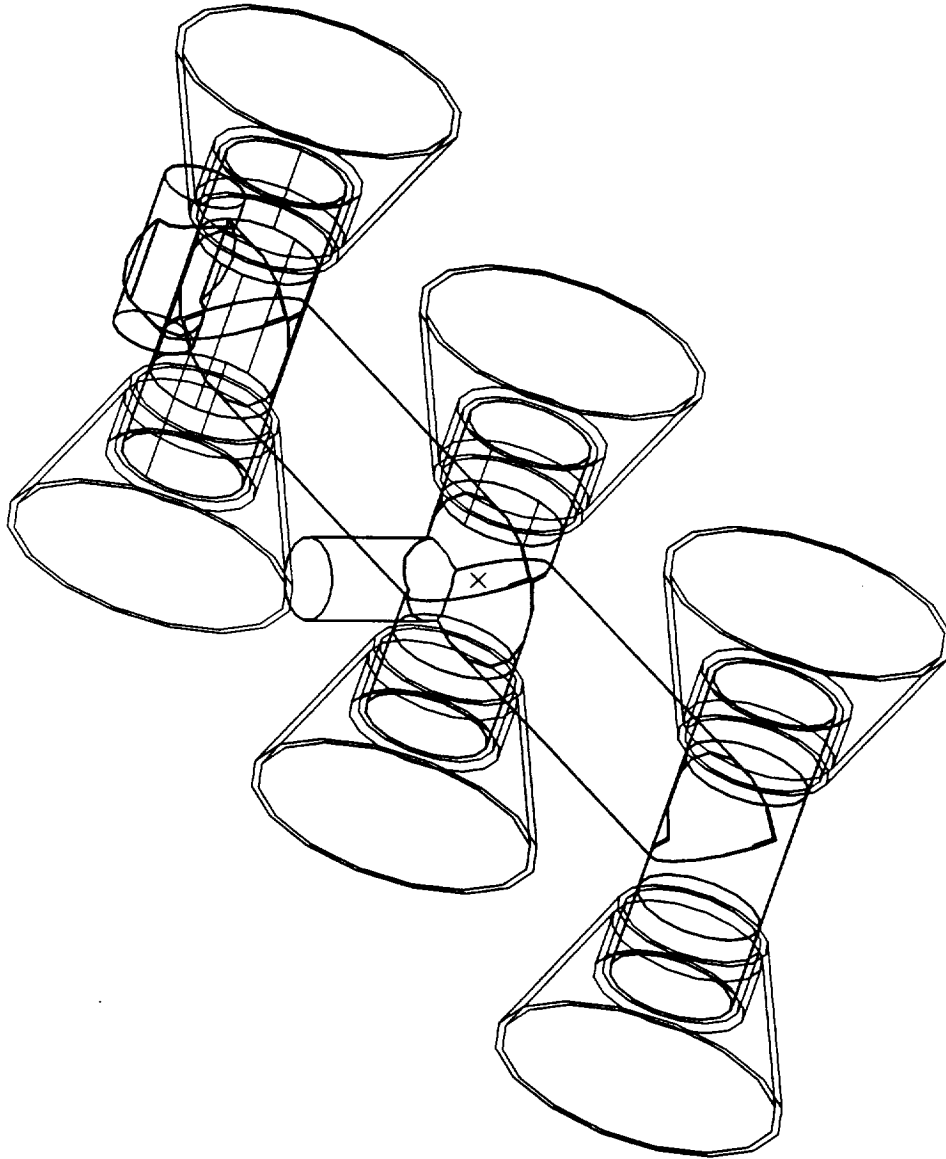

DRAWING No. SM-10

BY: JASON S. DELL

SDRC I-DEAS VI: Solid_Modeling

Database: none
View : No stored View
Task: Object
Object: I-SHELL, (M20000, N14) (Mod)

03-JUN-92 21:03:25

Units : IN
Display : No stored Option

Bin: I-WK18
Update Level: Pull

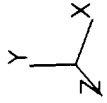
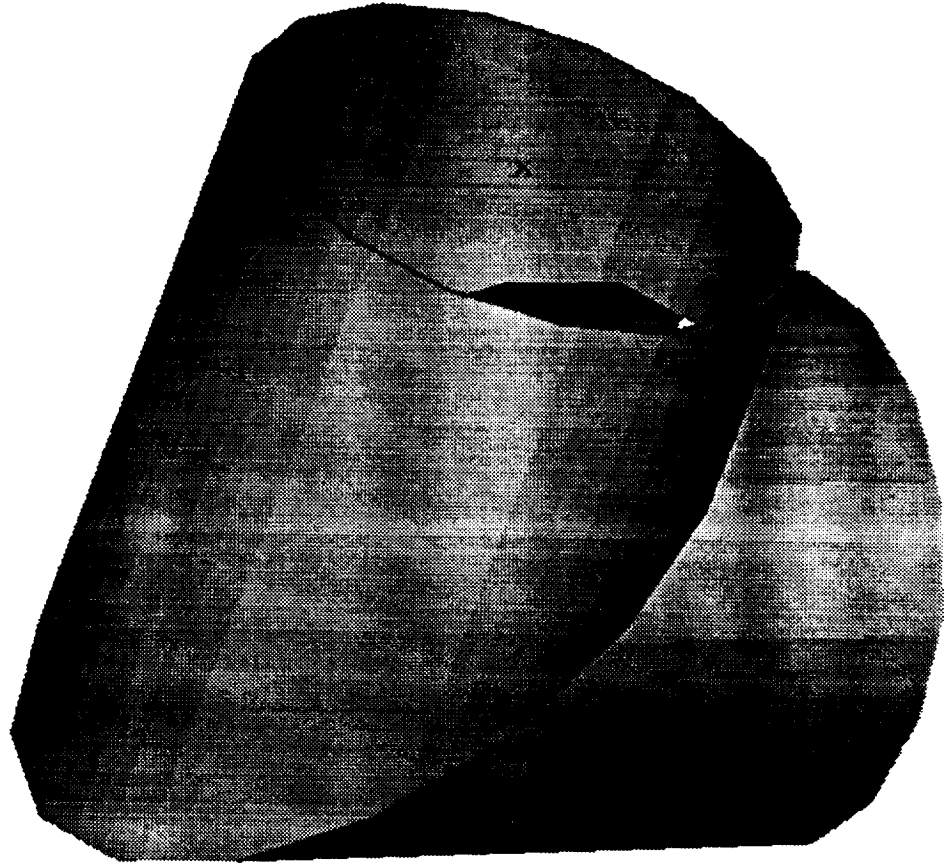

DRAWING No. SM-11

BY: JASON S. DELL

SDRC I-DEAS VI: Solid_Modeling

Database: none
View : No stored View
Task: Object
Object: 1-SHELL, (TOTAL 48 SURFAC, Blist) (Mod)

03-JUN-92 20:46:55

Units : IN
Display : No stored Option

Dir: I-DEAS
Update Level: Full

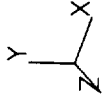
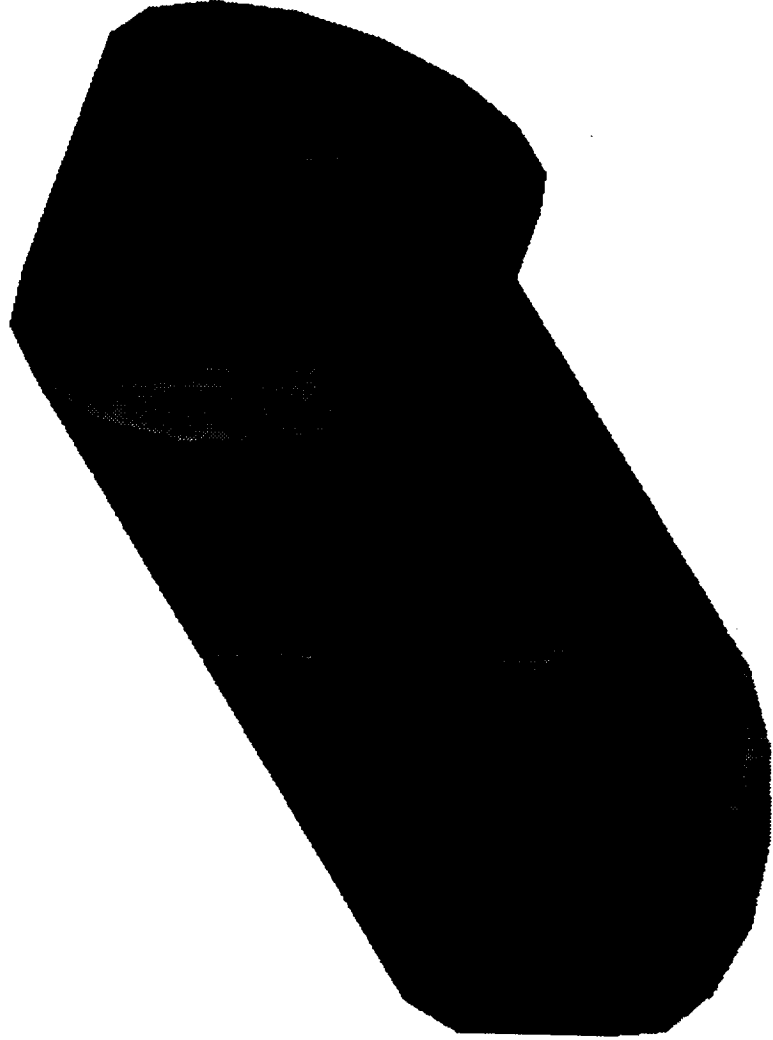

DRAWING NO. SM-12

BY: JASON S. DELL

TOP VIEW

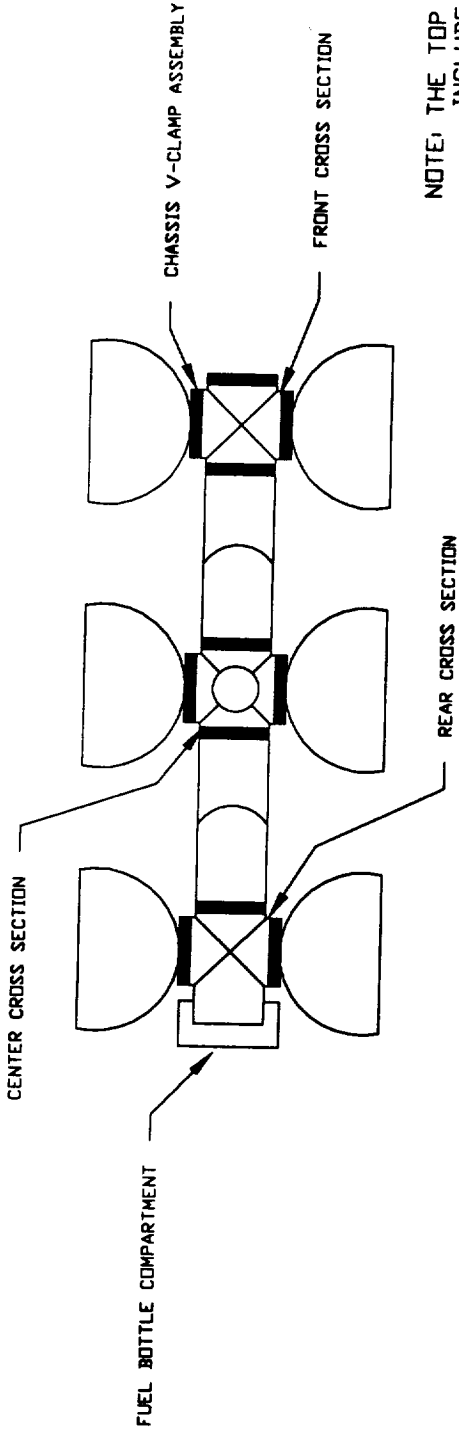

NOTE: THE TOP VIEW DOES NOT INCLUDE THE BOOM.

SIDE VIEW

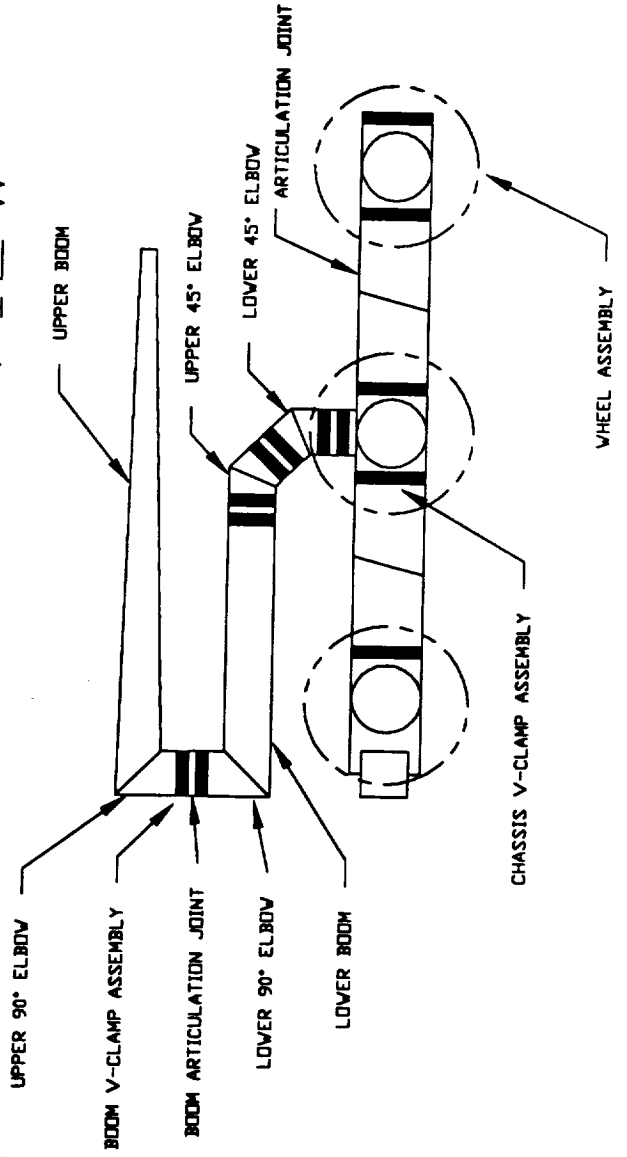

ENABLER ASSEMBLY	AS-1
CHASSIS/BOOM GROUP 1	
JUNE 9, 1992	
BRENT NELSON	

DRAWING No. AS-1

NOTES:

1. THICKNESS TO BE 1/8"
2. MATERIAL IS ALUMINUM 6061-T6

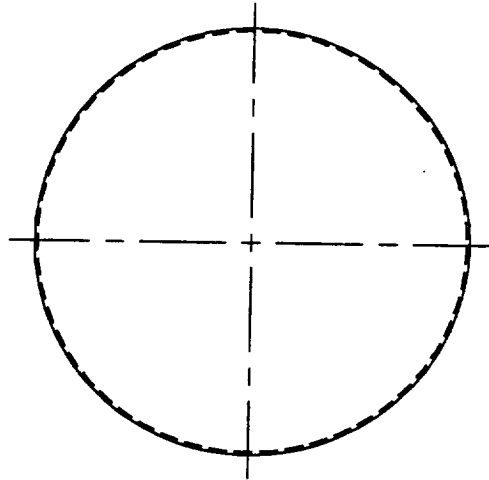
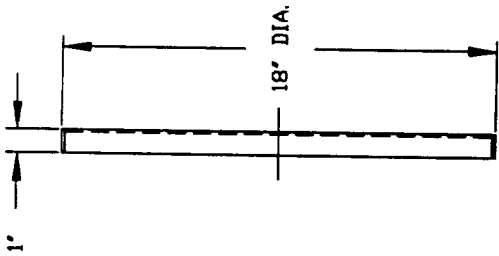

FACE PLATE	PART # CH-1
ENABLER CHASSIS/BOOM GROUP1	
JUNE 9, 1992	
JASON S. DELL	

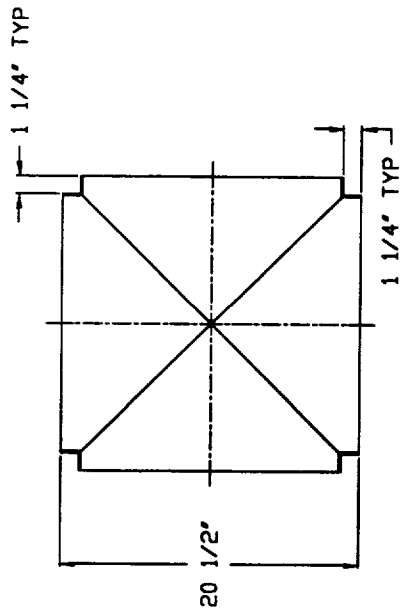

NOTES:

1. THICKNESS TO BE 1/8"
2. ALUMINUM 6061 ALLOY

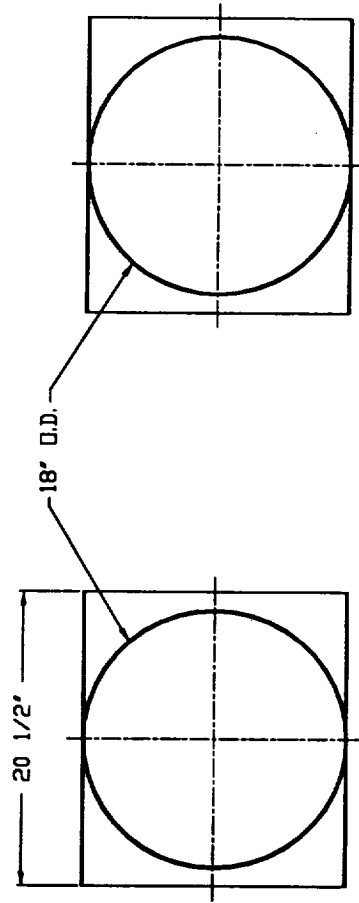

PART # CH-2
 - REVISION #2

FRONT END SECTION
 1"=1' 6/3/92
 ENABLER
 JASON S. DELL

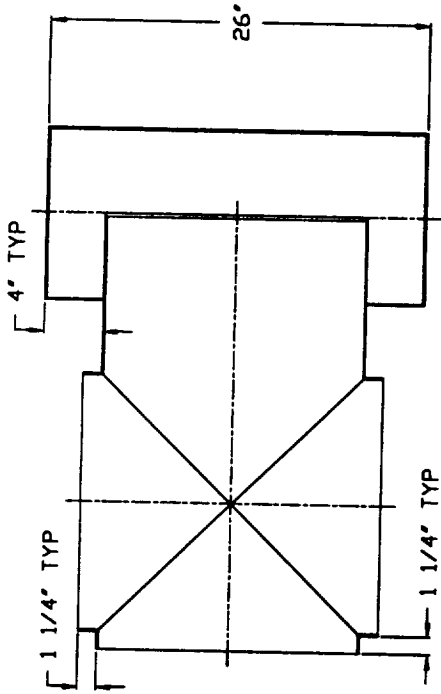

NOTES:

1. THICKNESS TO BE 1/8"
2. ALUMINUM 6061 ALLOY

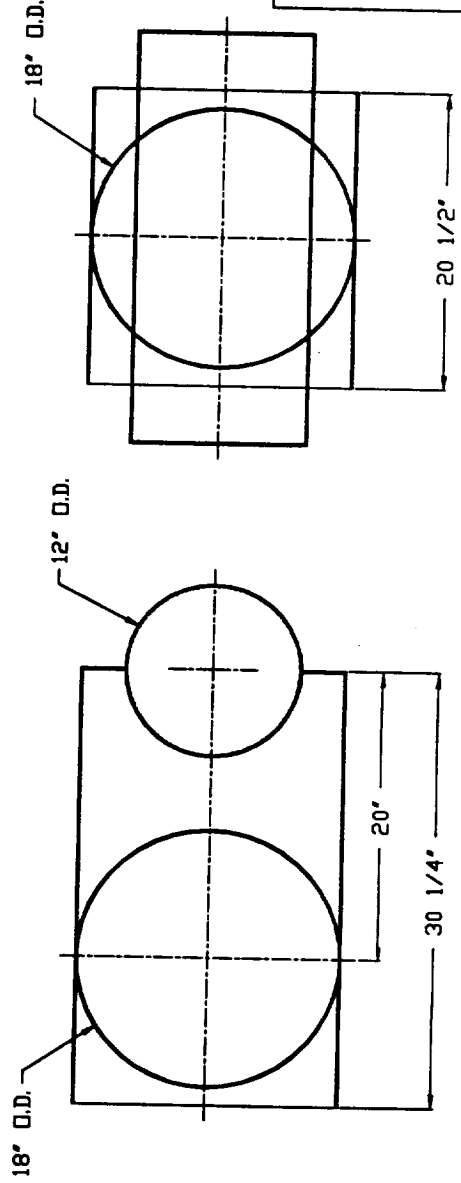

REAR END SECTION
 1"=1' 6/3/92
 ENABLER CH-3
 JASON S. DELL

NOTES:

- 1) Material is 1/8" thick 6061 Aluminum alloy

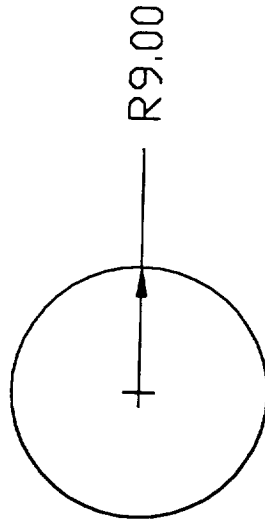
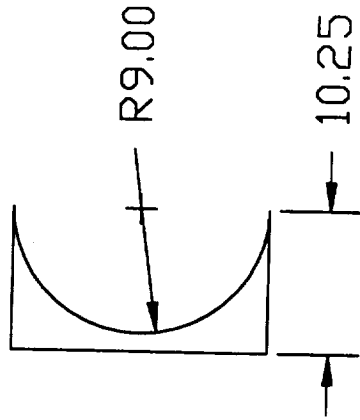
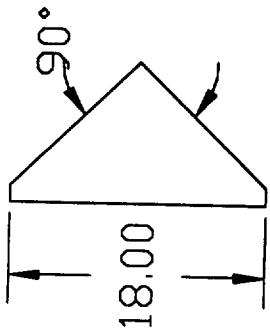

END SECTION
QUARTER PANEL
part drawing
CH-4
Tom Winchell

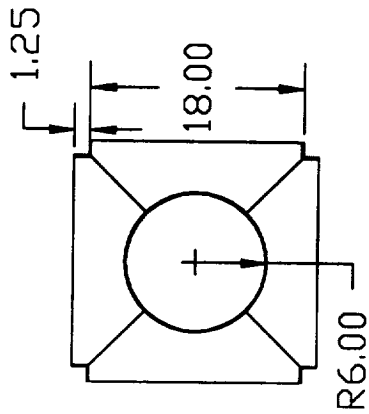

Notes:

- 1) All dimensions are in inches
- 2) All parts are 1/8" thick 6061 Aluminum alloy

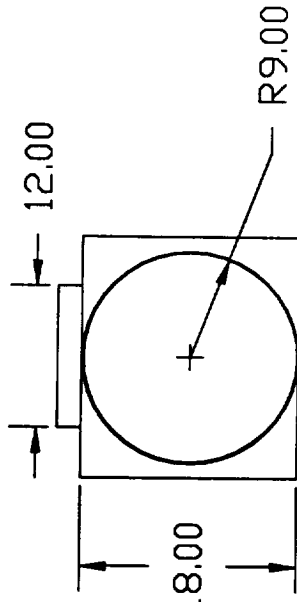
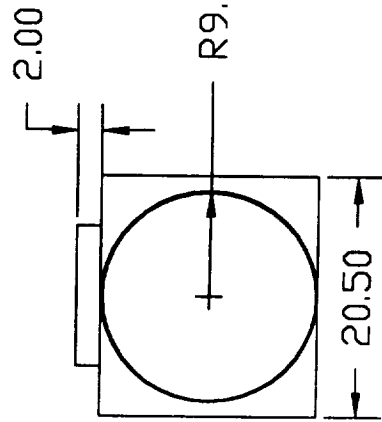

Assembly
Center Chassis
Section
CH-5
Tom Winchell
1 inch = 1 foot

NOTES:

- 1) Material is 1/8" thick 6061 Aluminum alloy

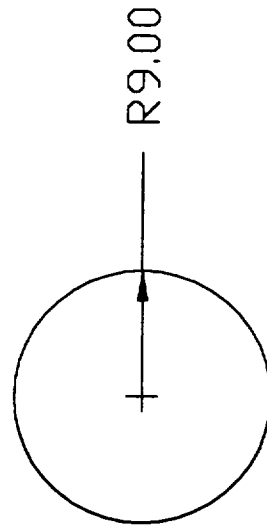
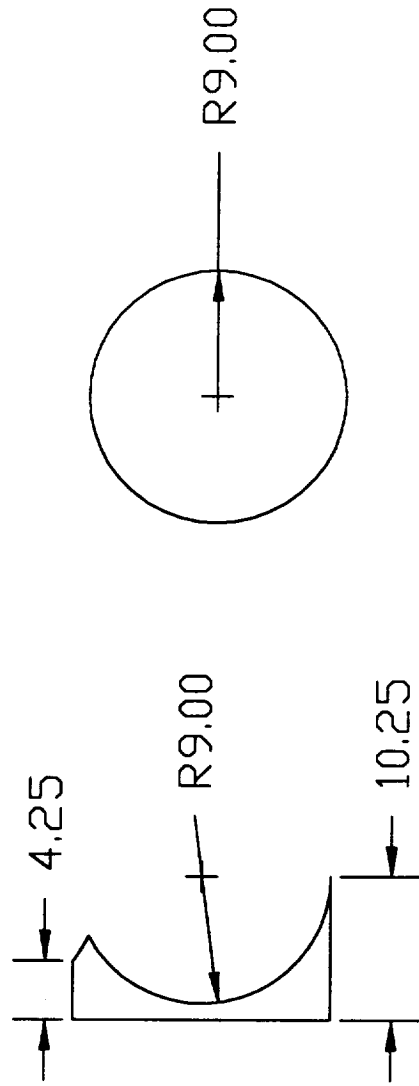
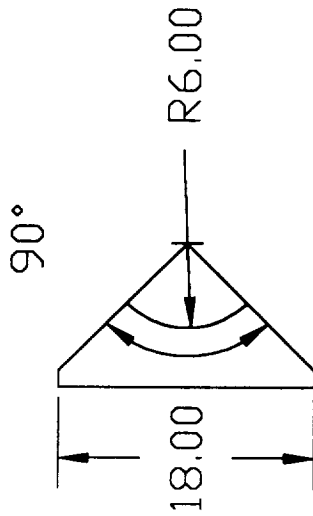

CENTER SECTION

QUARTER PANEL

part drawing

CH-6

Tom Winchell

Notes:

- 1) Material is 1/8" thick 6061 Aluminum alloy

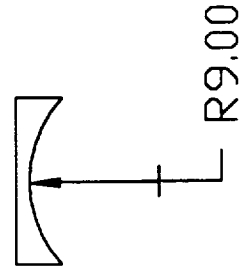
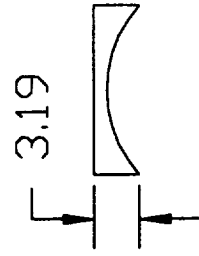
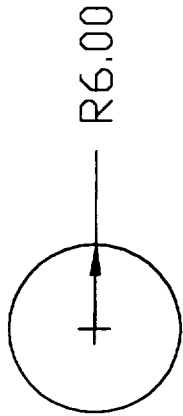

CHASSIS / BOOM
INTERFACE CYLINDER

part drawing

CH-7

Tom Winchell

SEE DETAIL DRAWING
FOR THE DIMENSIONS

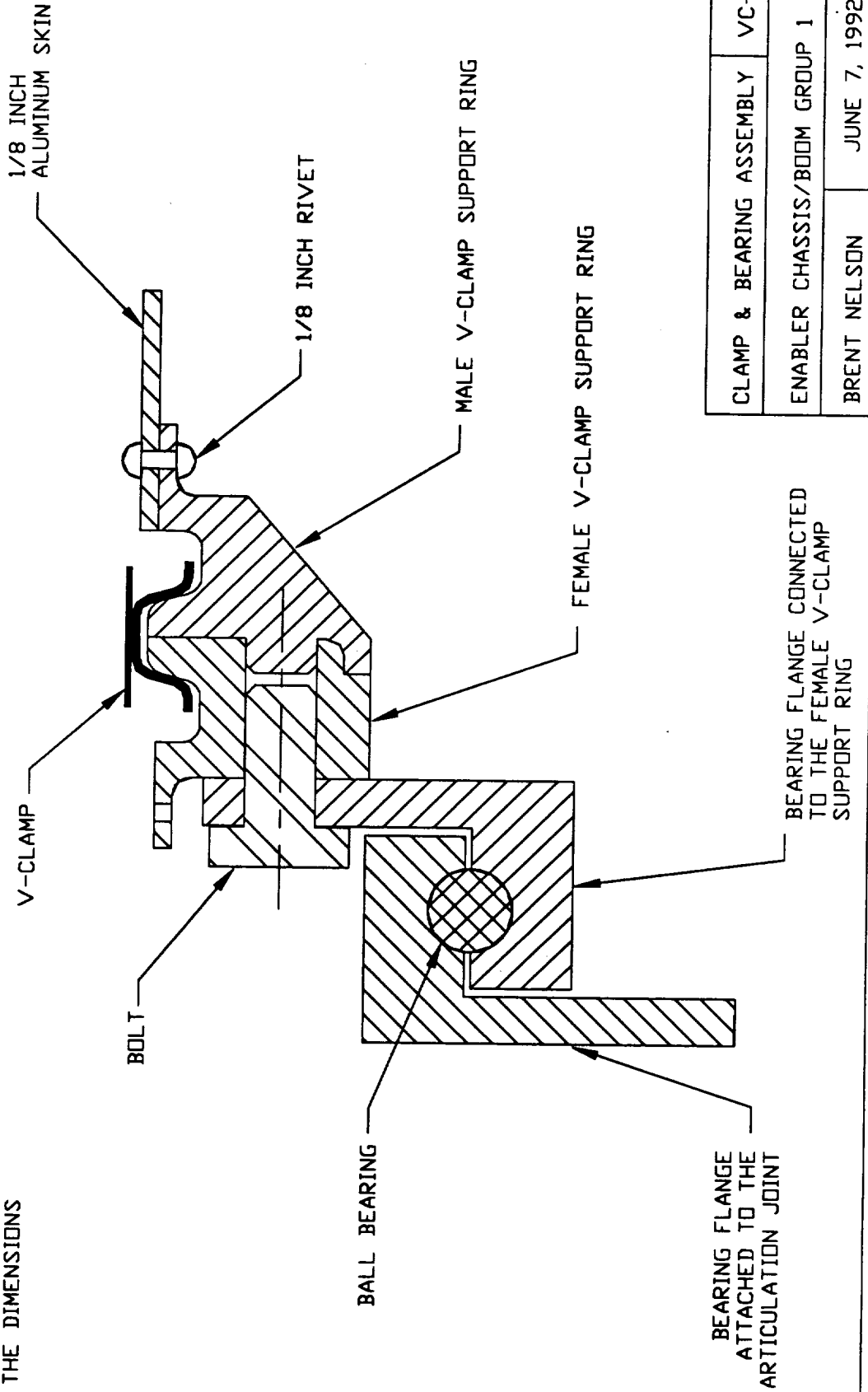

CLAMP & BEARING ASSEMBLY	VC-1
ENABLER CHASSIS/BOOM GROUP 1	
BRENT NELSON	JUNE 7, 1992

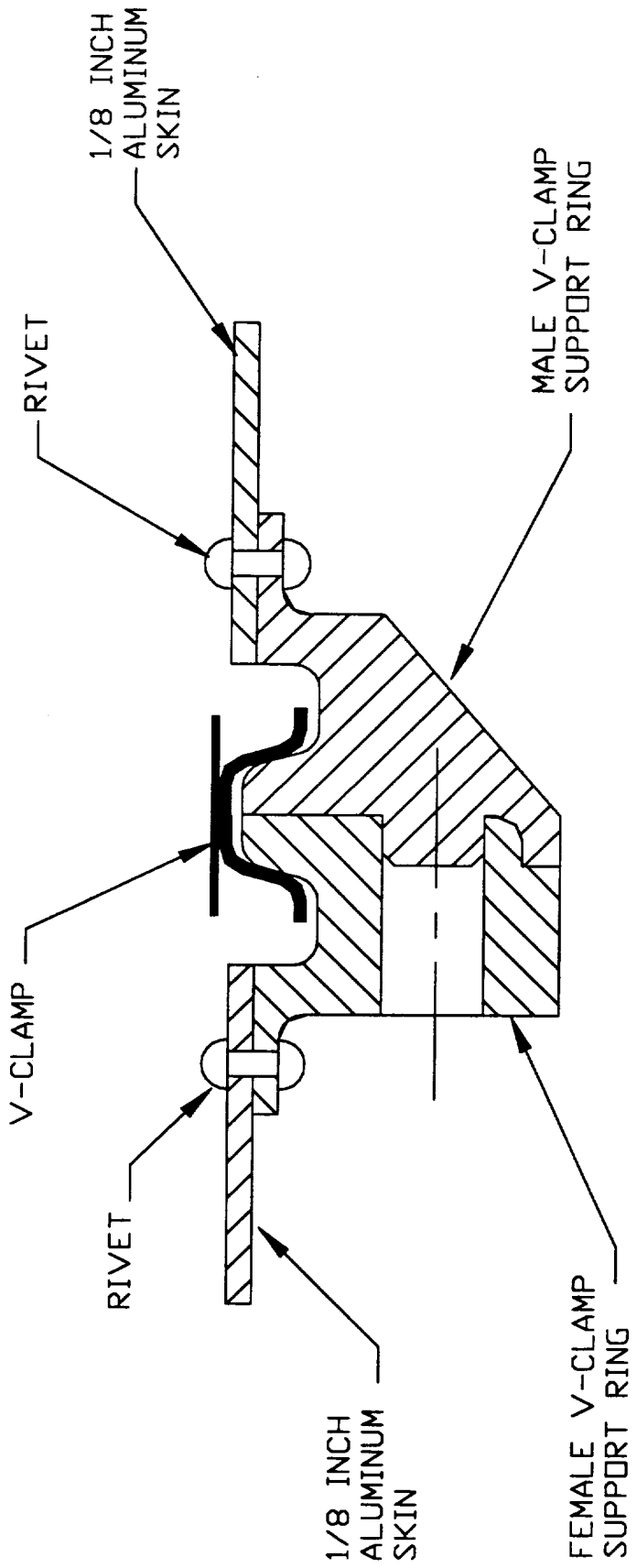

CLAMP ASSEMBLY	VC-2
ENABLER CHASSIS/BOOM GROUP 1	
BRENT NELSON	JUNE 7, 1992

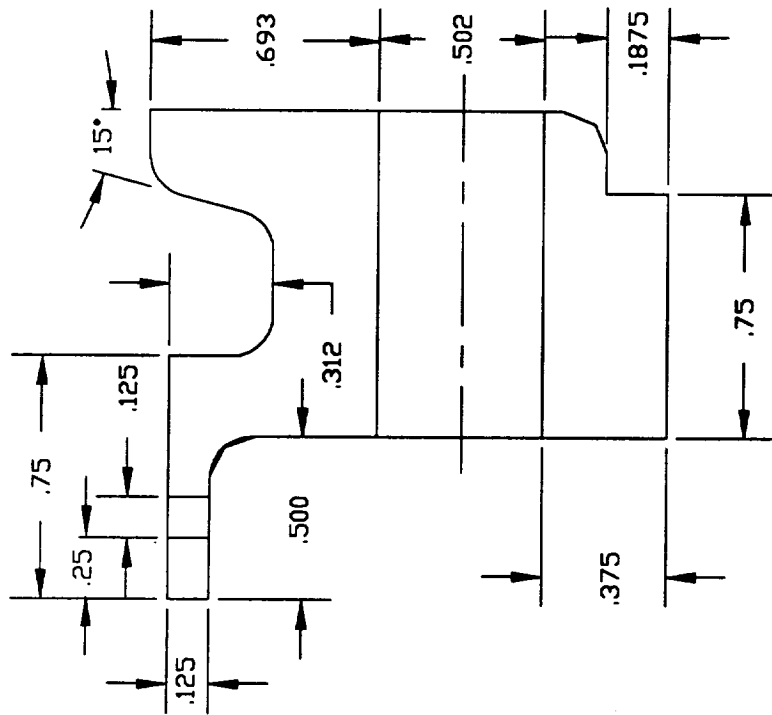

NOTE: ALL FILETS AND ROUNDS ARE .125 RADIUS.

FEMALE V-CLAMP	VC-3
ENABLER CHASSIS/BOOM GP 1	
JUNE 11, 1992	
BRENT NELSON	

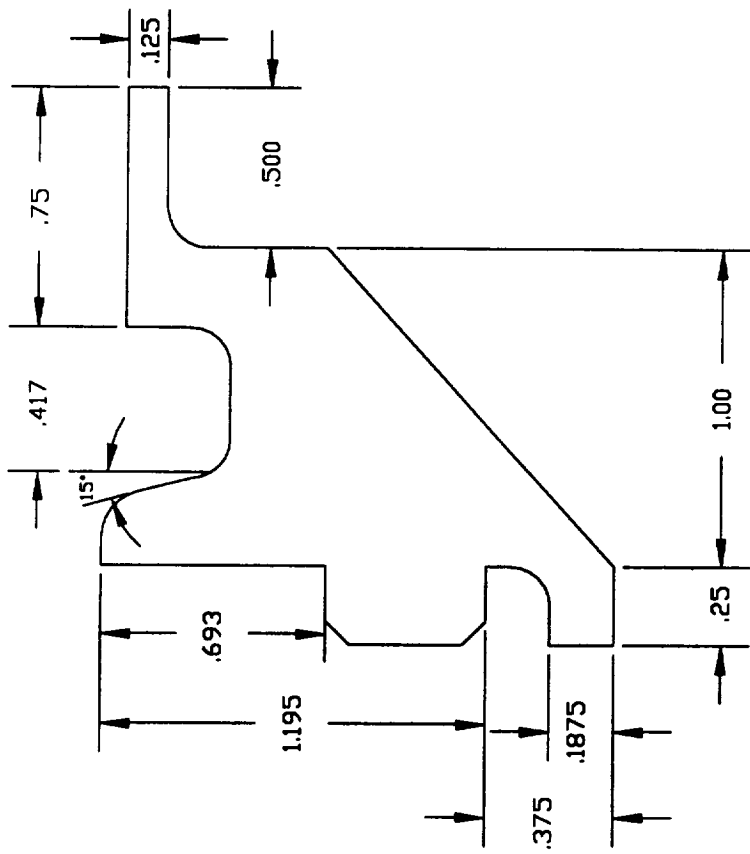

NOTE: ALL FILLETS AND ROUNDS
ARE .125 RADIUS

MALE V-CLAMP	VC-4
ENABLER CHASSIS/BOOM GROUP 1	
BRENT NELSON	JUNE 7, 1992

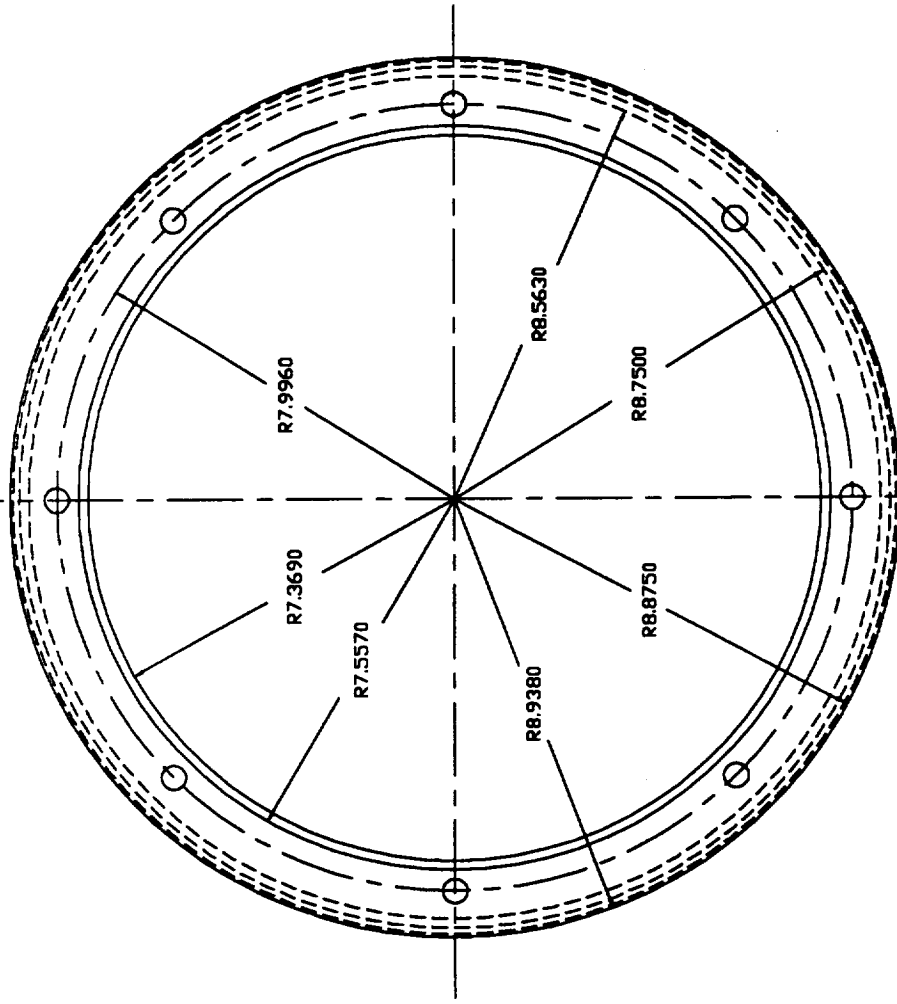

CHASSIS FEMALE V-CLAMP SUPPORT RING	
ENABLER CHASSIS/BOOM GROUP 1	
JUNE 4, 1992	VC-5
BRENT NELSON	

MATERIAL IS 6061 ALUMINIUM
 FOR DIMENSIONS OF THE CROSS SECTION SEE THE DETAIL DRAWING

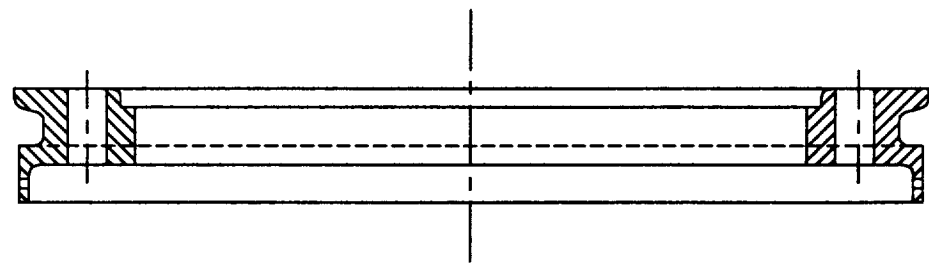
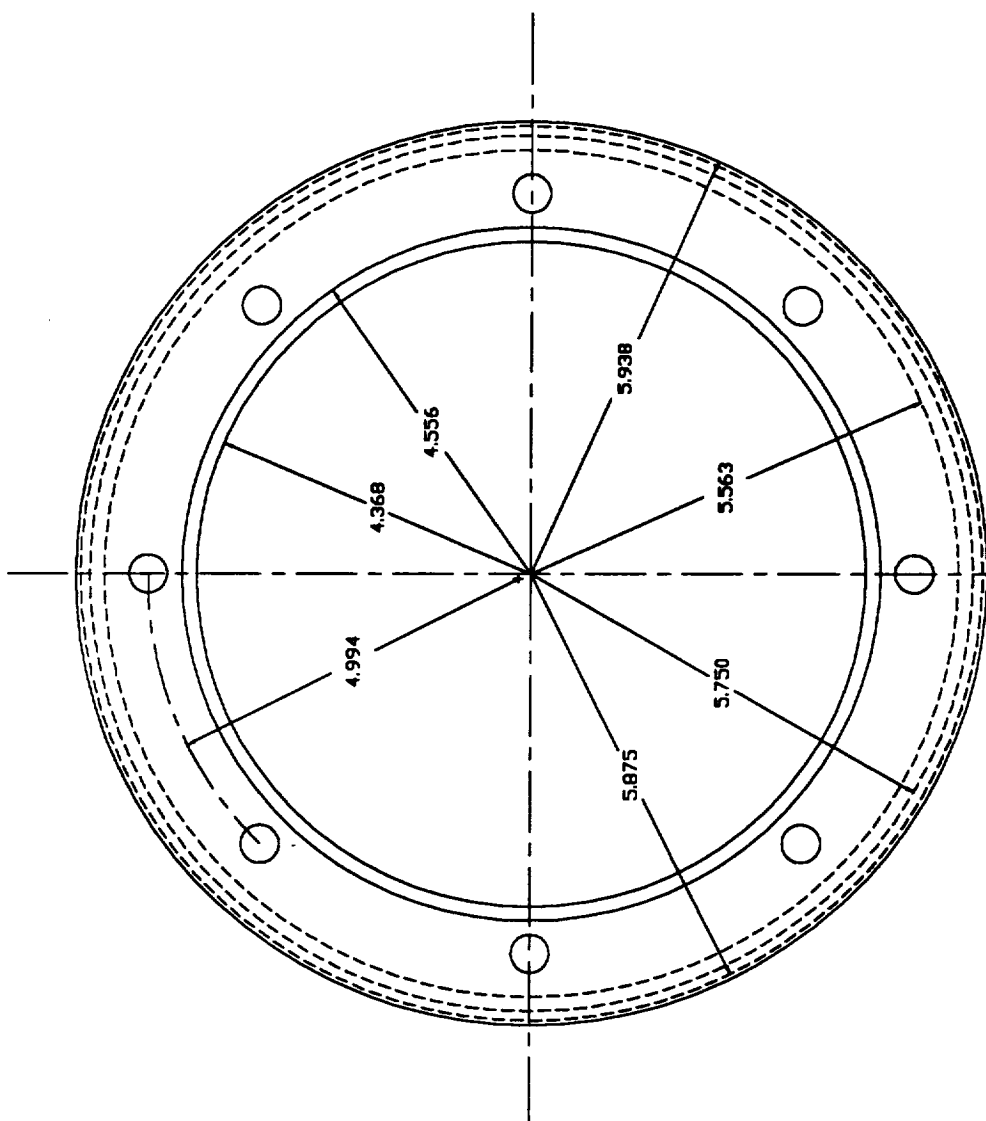

MATERIAL IS 6061 ALUMINUM
 FOR DIMENSIONS OF THE CROSS SECTION SEE THE DETAIL DRAWING

BOOM FEMALE V-CLAMP SUPPORT RING	
ENABLER CHASSIS/BOOM GROUP 1	
JUNE 4, 1992	VC-6
BRENT NELSON	

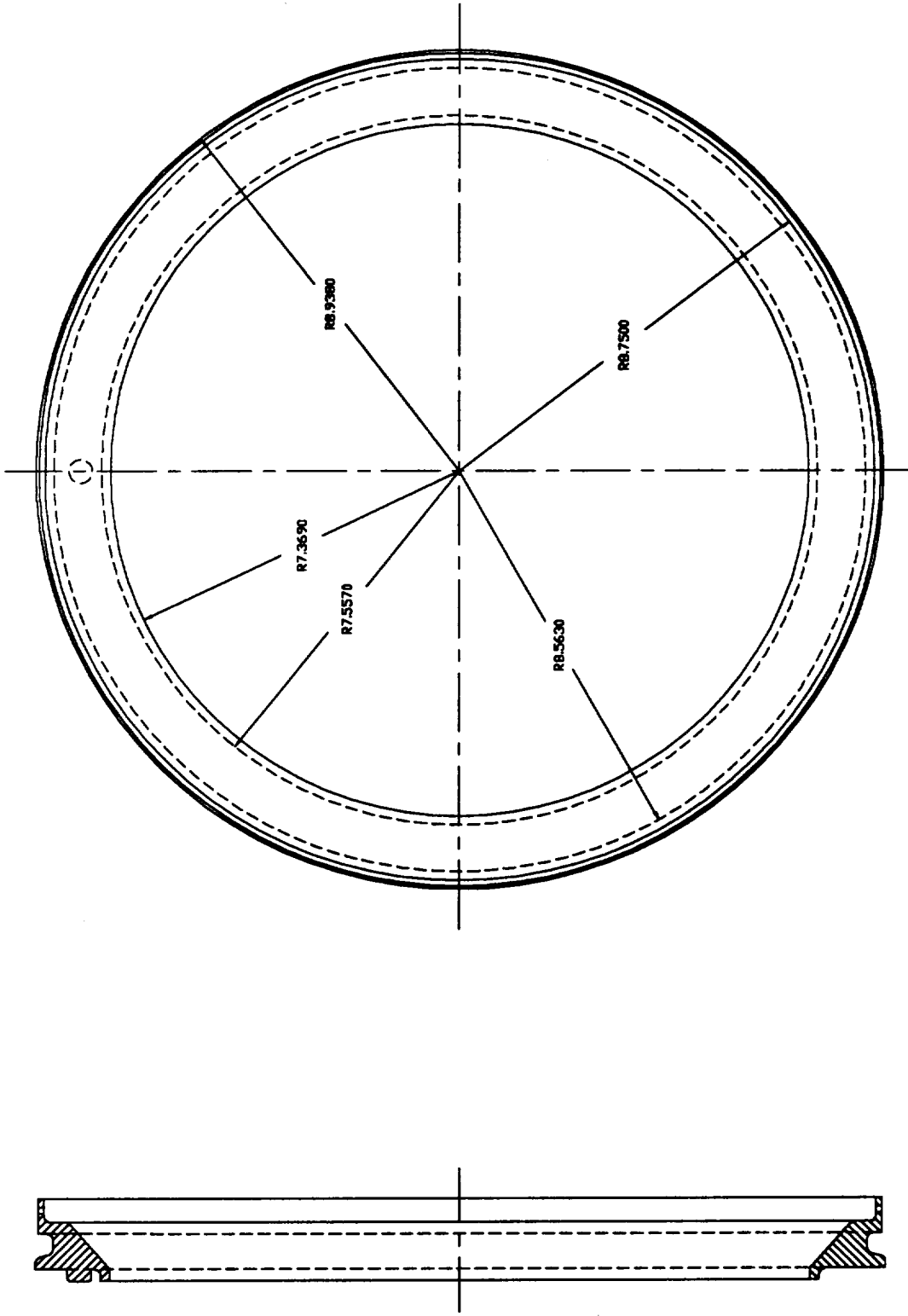

R8.9380

R8.7500

R7.3690

R7.5570

R8.5630

MATERIAL IS 6061 ALUMINUM

FOR DIMENSIONS OF THE CROSS SECTION SEE THE DETAIL DRAWING

CHASSIS MALE V-CLAMP SUPPORT RING

ENABLER CHASSIS/BOOM GROUP 1

JUNE 4, 1992

VC-7

BRENT NELSON

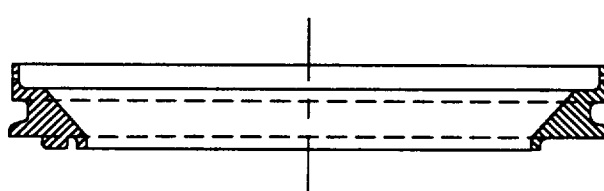
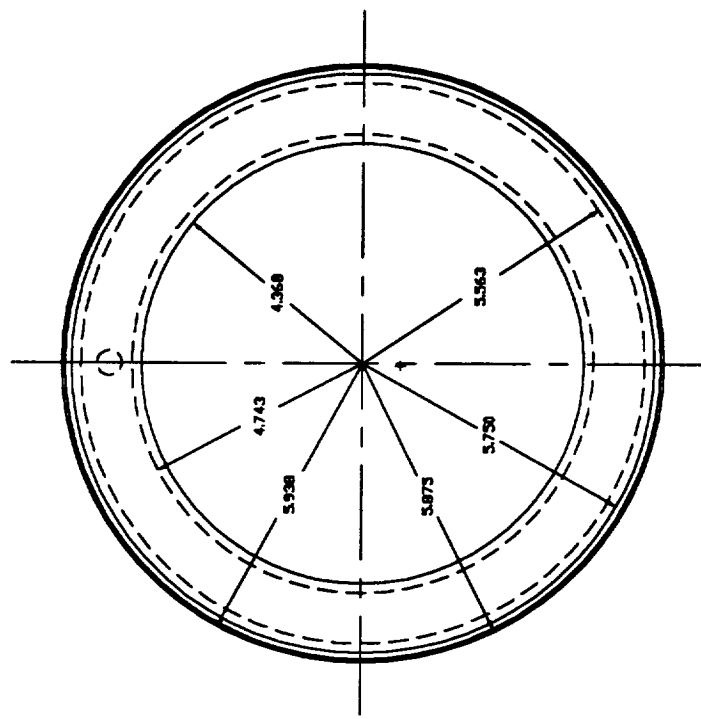

MATERIAL IS 6061 ALUMINUM

FOR DIMENSIONS OF THE CROSS SECTION SEE THE DETAIL DRAWING

BOOM MALE V-CLAMP SUPPORT RING	
ENABLER CHASSIS/BOOM GROUP 1	
JUNE 4, 1992	VC-8
BRENT NELSON	

UPPER BOOM DIMENSIONS

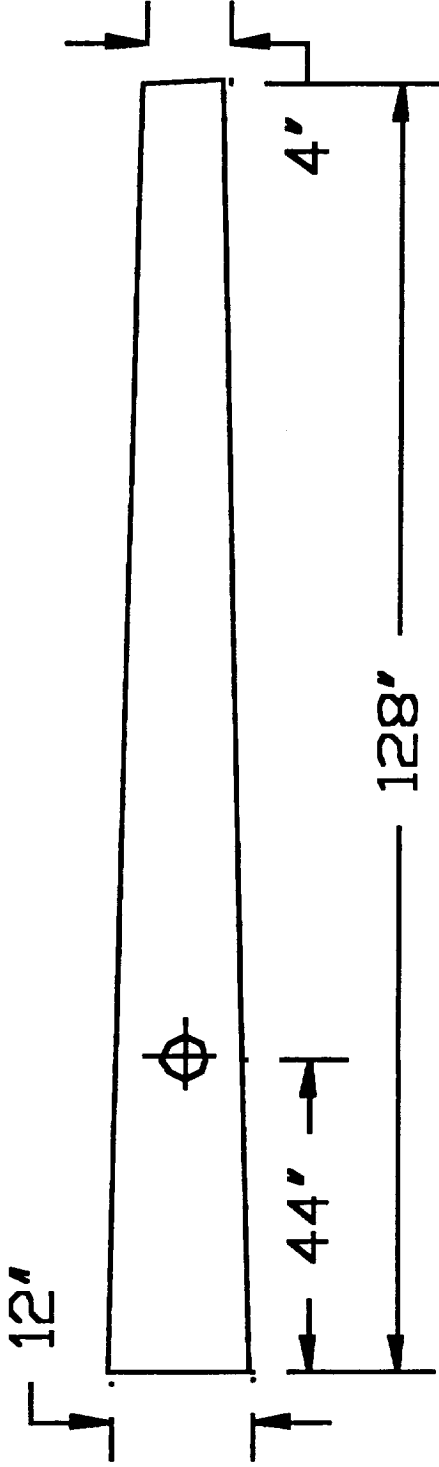

WEIGHT: 20 LB
MATERIAL: ALUMINUM 6061

Drawing No.: BM-1

TITLE	UPPER BOOM DIMENSIONS	
PROJECT	LUNAR ENABLER	
DATE	5/10/92	BY KELLY MERKEL

LOWER BOOM AND ELBOW ASSEMBLY

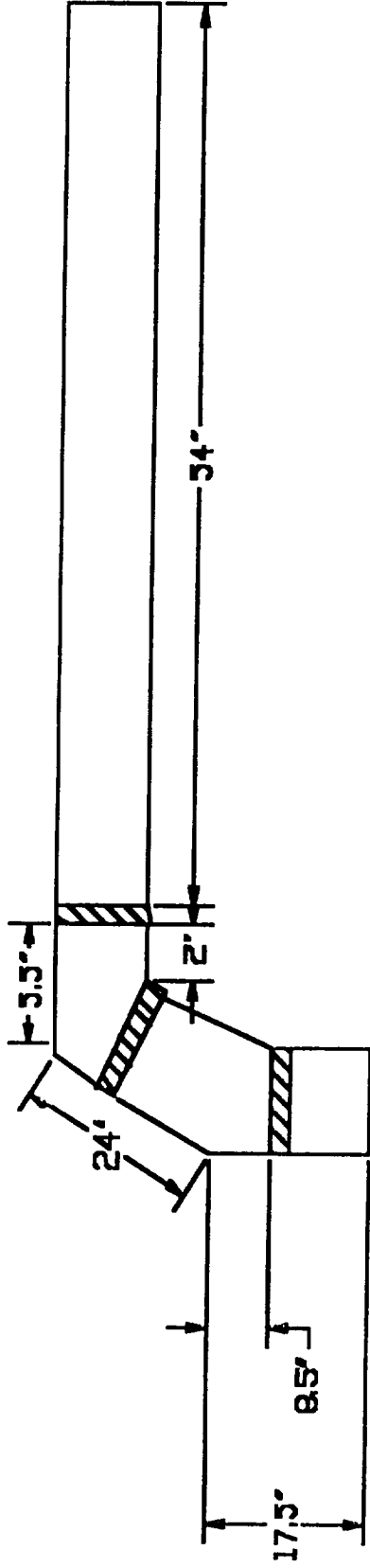

WEIGHT: 39 LBS (WITHOUT CLAMPS OR JOINTS)
MATERIAL: ALUMINUM 6061

Drawing No.: BM-2

Title:	LOWER BOOM ASSEMBLY	
Project:	LUNAR ENABLER	
Date:	6/10/92	By: KAN

LOWER BOOM EXTENSION

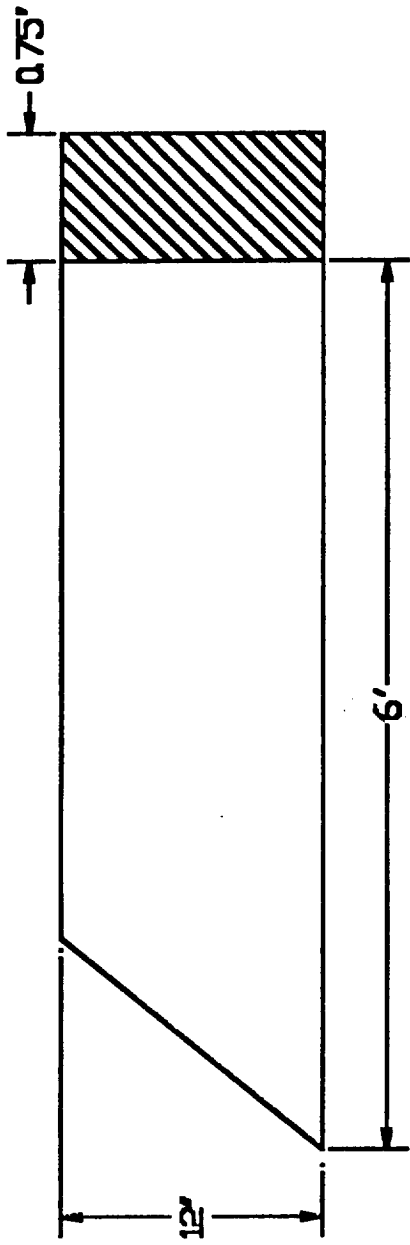

- Aluminum 6061 cylinder
- 45-degree cut on left face
- Depiction of V-clamp

Drawing No.: BM-3

Title LOWER EXTENSION	
Project: ENABLER	
Date: 6/4/92	By: KAM

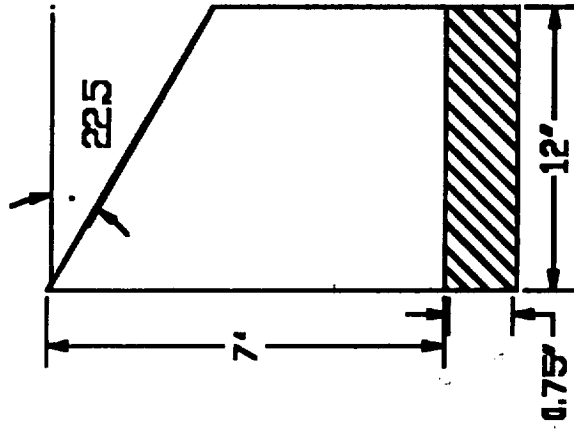
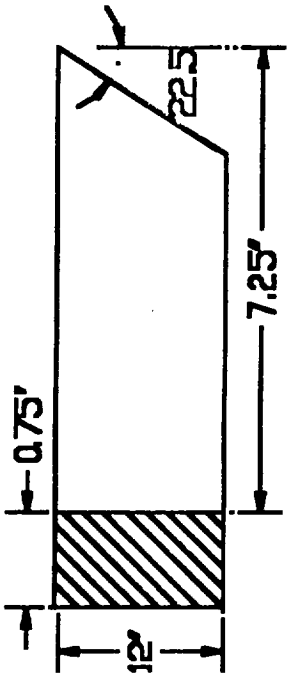

LOWER ELBOW

- Aluminum 6061 cylinders
- 1/8" thickness
- V-clamps on each side of joint
- Cuts at 22.5 degrees

Drawing No.: BM-4

Title		LOWER ELBOW	
Project		ENABLER	
Date	By	KAM	
6/4/92			

UPPER ELBOW SEGMENTS WITH V-CLAMPS

- 6061 Aluminum cylinder
- 1/8" uniform thickness
- V-clamps shown on each side of joint

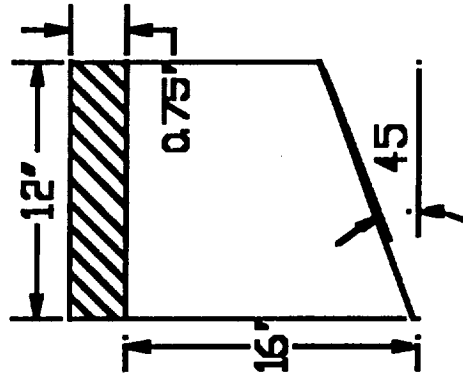
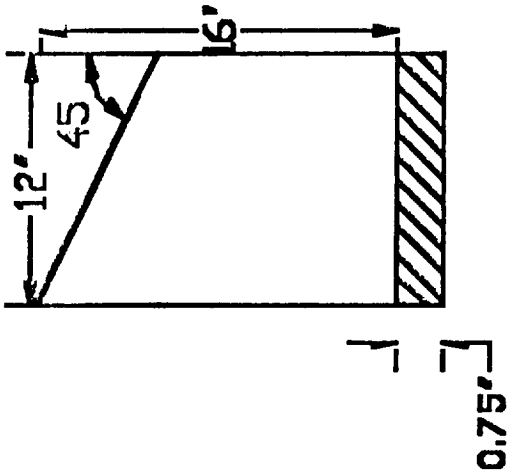

Drawing No.: BM-5

Title		UPPER ELBOW
Project		ENABLER
Date:	By:	KAM
6/4/92		

APPENDIX XI.2
HAND-DONE CALCULATIONS

LOWER BOOM CALCULATIONS

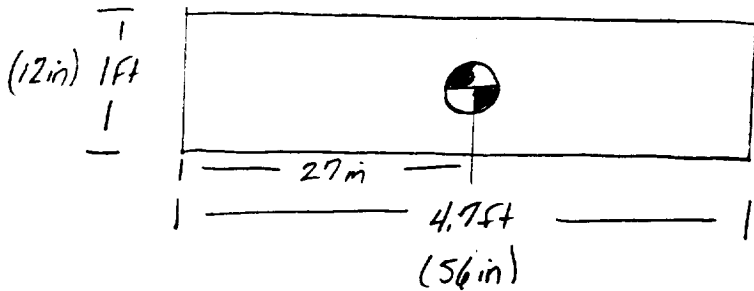

THICKNESS = 1/8 in

CENTER OF GRAVITY : 27 in

DEAD LOAD CALCULATION :

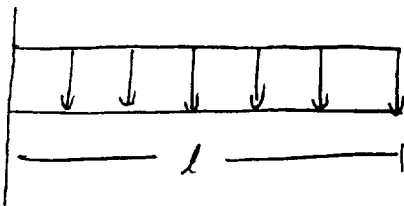

$$y_{max} = \frac{-Wl^3}{8EI}$$

$$= .0013 \text{ in}$$

$$W = 25 \text{ lbs}$$

$$l = 56$$

$$E = 10,000 \text{ ksi}$$

$$I = \frac{\pi}{64} (12^4 - 11.875^4)$$

$$= 41.75 \text{ in}^4$$

DEFLECTION WITH WEIGHTS OF UPPER BOOM, ELBOWS, ARTICULATION JOINT AND 101b LOAD APPLIED

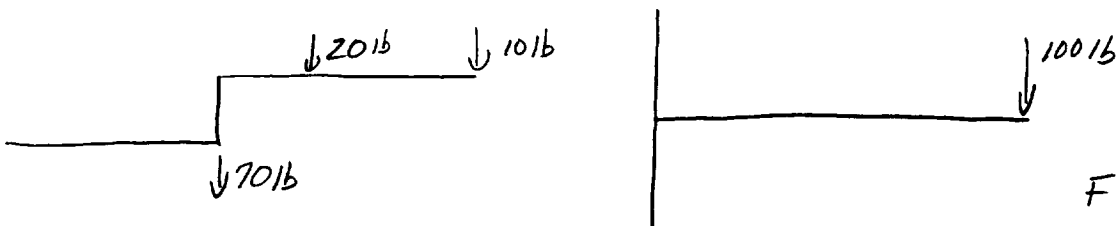

$$y_{max} = \frac{-Fl^3}{3EI} = .014 \text{ in}$$

$$F = 100 \text{ lb}$$

$$l = 56 \text{ in}$$

$$E = 10,000 \text{ ksi}$$

$$I = 41.75 \text{ in}^4$$

STRESS ANALYSIS : yield = 8000 psi

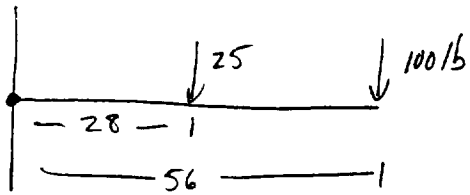

$$\sigma = \frac{Mc}{I} = \frac{6300(6)}{41.75} = 905.39 \text{ psi}$$

$$M = 25(28) + 100(56) = 6300$$

$$c = 6 \text{ in}$$

$$I = 41.75 \text{ in}^4$$

SHEAR ANALYSIS : shear yield $\approx .55S_y = 4000 \text{ psi}$

$$S_v = \frac{2V}{A}$$

$$V = 125$$

$$= \frac{2(125)}{9.38}$$

$$A = \pi(12^2 - 11.875^2) = 9.38$$

$$= 26.65 \text{ psi} \quad \text{SMALL COMPARED TO BENDING}$$

TORSION ANALYSIS

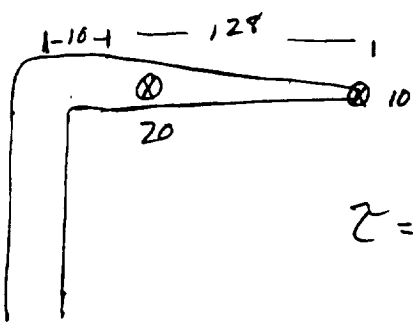

$$T = 10(138) + 20(54) = 2460$$

10 inches
From boom to
center of lower
boom

$$\tau = \frac{Tr}{J} = \frac{2460(6)}{83.50} = 176.77 \text{ psi}$$

$$J = \frac{\pi}{32} (D_o^4 - D_i^4)$$

$$= 83.50$$

SMALL COMPARED TO BENDING

CHECK TO INSURE LOWER BOOM WILL SUPPORT MAX LOAD ON UPPER BOOM. (29.23 lb)

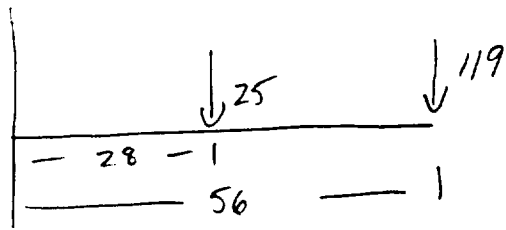

$$M = 119(56) + 25(28)$$
$$= 7364$$

$$S_y = 8000 \text{ psi}$$

$$c = 6 \text{ in}$$

$$I = 41.75 \text{ in}^4$$

$$\sigma = \frac{Mc}{I} = \frac{7364(6)}{41.75} = 1058.3 \text{ psi} \quad \text{IT WILL SUPPORT IT}$$

UPPER BOOM CALCULATIONS

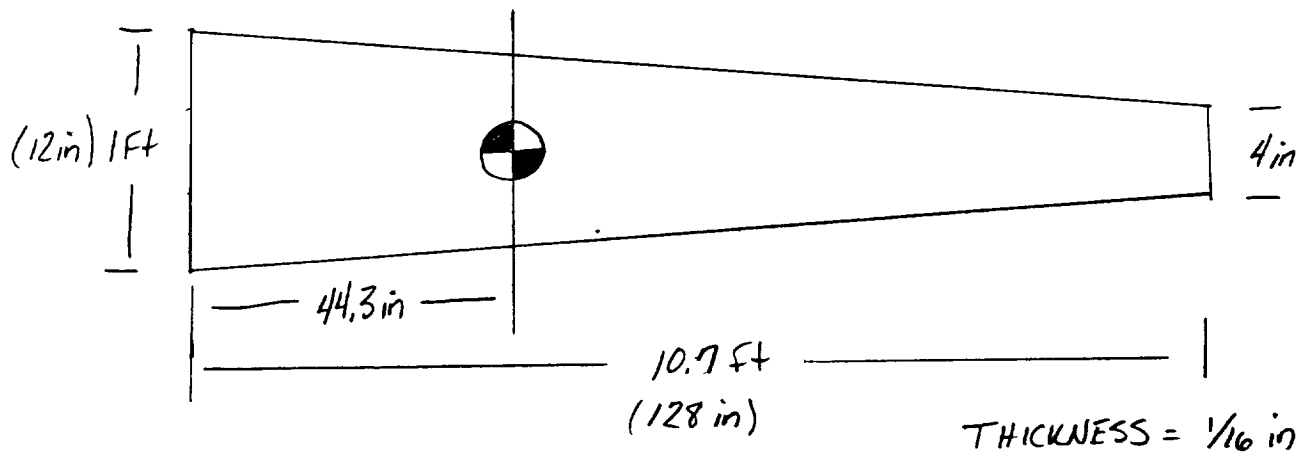

CENTER OF GRAVITY:

$$CG = \frac{h(R^2 + 2Rr + 3r^2)}{4(R^2 + Rr + r^2)}$$

$$= 44.3 \text{ in}$$

$$R = 6 \text{ in}$$

$$r = 2 \text{ in}$$

$$h = 128 \text{ in}$$

DEAD LOAD CALCULATION:

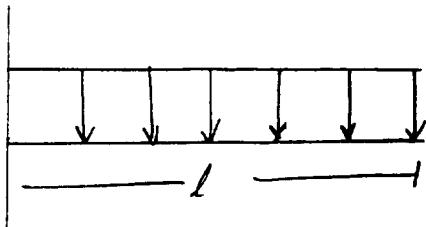

$$y_{max} = \frac{-Wl^3}{8EI}$$

$$= .68 \text{ in}$$

$$W = 20 \text{ lb}$$

$$l = 128 \text{ in}$$

$$E = 10,000 \text{ Ksi}$$

$$I = \frac{\pi}{64} (D_o^4 - D_i^4)$$

$$= .77 \text{ in}^4$$

MODELED AS BEAM WITH CONSTANT $D_o = 4 \text{ in}$
AND 1/16 in THICKNESS

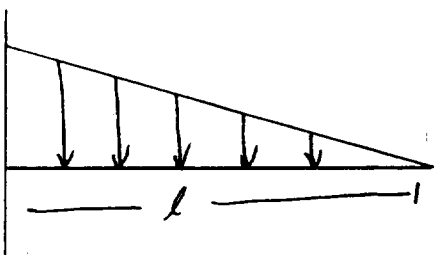

$$y_{max} = \frac{-Wl^3}{15EI} = .36 \text{ in}$$

$$\text{TOTAL DEFLECTION} = 1.04 \text{ in}$$

DEFLECTION WITH 10LB LOAD APPLIED :

MODEL AS CANTILEVER BEAM

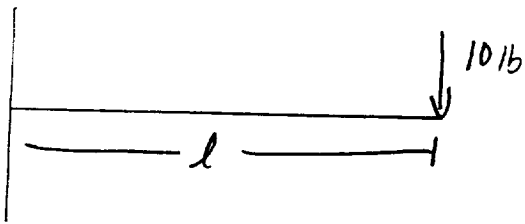

$$y_{max} = \frac{-Fl^3}{3EI}$$

$$= .91 \text{ in}$$

$$F = 10 \text{ lb}$$

$$l = 128 \text{ in}$$

$$E = 10,000 \text{ ksi}$$

$$I = .77 \text{ in}^4$$

STRESS ANALYSIS : YIELD STRENGTH = 8000 psi $C = 6 - \frac{4x}{128}$

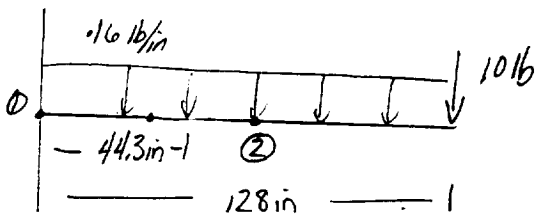

$$\sigma = \frac{Mc}{I}$$

$$I = \frac{\pi}{64} (D_o^4 - D_i^4)$$

MODEL WEIGHT AS RECTANGULAR
DISTRIBUTED LOAD $\frac{20 \text{ lb}}{128 \text{ in}} = .16 \text{ lb/in}$

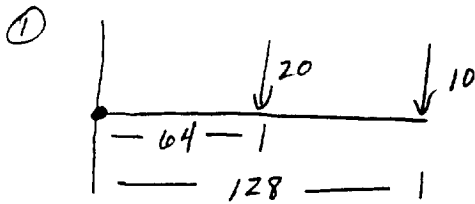

$$M = 10(128) + 20(64) = 2560$$

$$I = \frac{\pi}{64} (12^4 - 11.9375^4) = 21.04 \text{ in}^4$$

$$c = 6 \text{ in}$$

$$\sigma = \frac{2560(6)}{21.04} = 730.03 \text{ psi}$$

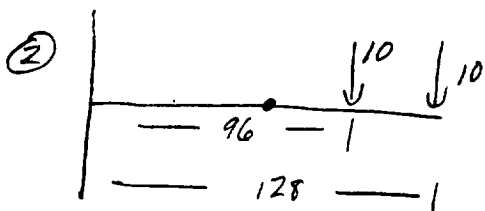

$$M = 10(64) + 10(32) = 960$$

$$I = \frac{\pi}{64} (8^4 - 7.9375^4) = 6.21 \text{ in}^4$$

$$c = 4 \text{ in}$$

$$\sigma = \frac{960(4)}{6.21} = 618.35 \text{ psi}$$

③

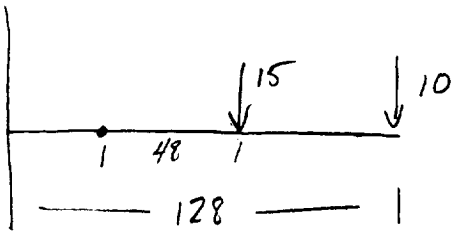

$$M = 10(96) + 15(48) = 1680$$

$$I = \frac{\pi}{64} (10^4 - 9.9375^4) = 12.16 \text{ in}^4$$

$$c = 5 \text{ in}$$

$$\sigma = \frac{1680(5)}{12.16} = 690.79 \text{ psi}$$

SHEAR ANALYSIS: shear yield $\approx .5 S_y \approx 4000 \text{ psi}$

$$S_v(\text{max}) = \frac{2V}{A}$$

$$A = \pi (R^2 - r^2) \\ = \pi (4^2 - 3.9375^2) \\ = 1.56$$

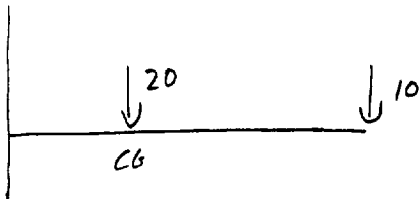

$$V = 30$$

$$S_v(\text{max}) = \frac{2(30)}{1.56} = 38.46 \text{ psi}$$

SMALL IN COMPARISON
TO BENDING STRESS

CALCULATION OF MAX APPLIED LOAD

MODEL UPPER BOOM AS CONSTANT $D_o = 6 \text{ in}$, THICKNESS = $1/16 \text{ in}$

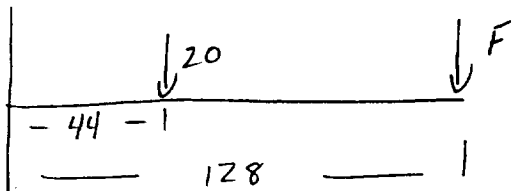

$$F.S. = 1.5 \quad S_y = 8000 \text{ psi}$$

$$\sigma = 5333 \text{ psi}$$

$$\sigma = \frac{Mc}{I}$$

$$M = 128F + 20(44) = 128F + 880$$

$$5333 = \frac{(128F + 880)3}{2.6}$$

$$c = 3 \text{ in}$$

$$I = \frac{\pi}{64} (6^4 - 5.9375^4) = 2.6$$

$$29.2316 = F$$

ENGINE EXTENSION CALCULATIONS

- REQUIREMENTS:
- 1) ENGINE EXTENSION MUST NOT CONTACT GROUND.
 - 2) LENGTH OF EXTENSION MUST BE MINIMUM OF 20" (MID-WHEEL TO END).
(GIVEN TO BY MOTOR/DRIVE GROUP)

1. FIND LOWEST POSSIBLE POINT OF ARTICULATION JOINT AND USE AS THE CONSTRAINT FOR THE END EXTENSION.

ARTICULATION WORST CASE:

X_m = CONSTRAINT DIMENSION

* = INDICATES FINAL DIMENSION (ON CAGE WALL)

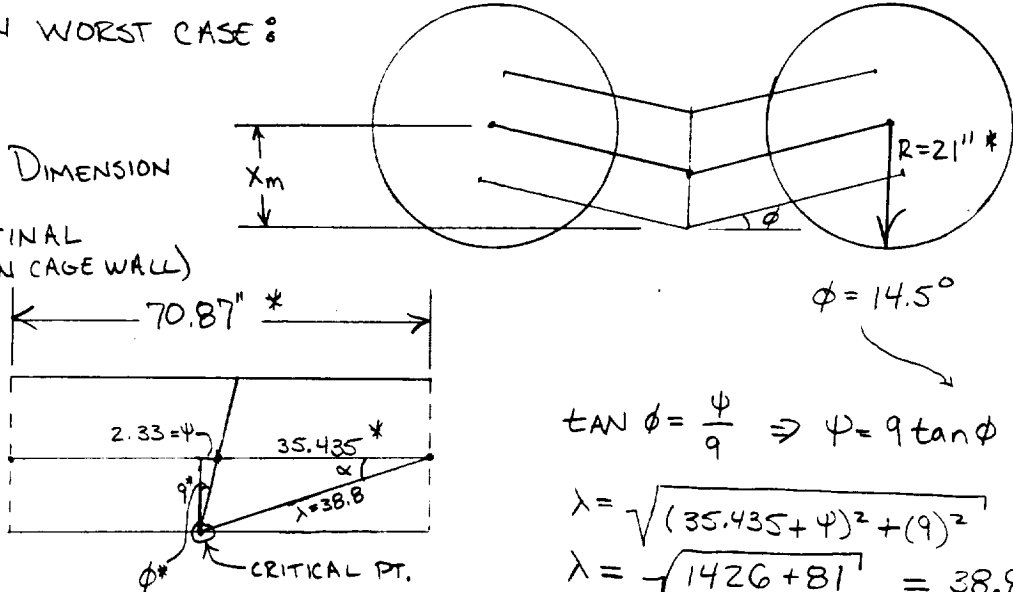

$$\tan \phi = \frac{\psi}{9} \Rightarrow \psi = 9 \tan \phi = 2.33$$

$$\lambda = \sqrt{(35.435 + \psi)^2 + (9)^2}$$

$$\lambda = \sqrt{1426 + 81} = 38.8$$

$$\tan \alpha = \left(\frac{9}{35.435 + 2.33} \right) \quad \alpha = 13.4^\circ$$

DEFLECTION OF CRITICAL PT. AT ROTATION

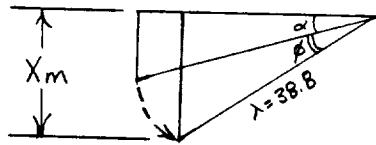

$$\sin(\alpha + \phi) = \frac{X_m}{\lambda}$$

$$\sin(27.9) = \frac{X_m}{38.8} \quad X_m = 18.2''$$

$$\underline{X_m = 18.2''}$$

NOTE: WITH THE WHEELS BEING ONLY 21" RADIUS, THERE IS ONLY 2.8" CLEARANCE BEFORE WHEEL DEFLECTION. WITH WHEEL DEFLECTION, THE ARTICULATION IS BOUND TO MAKE CONTACT WITH THE GROUND.

NEXT PAGE

2. USE X_m AS CONSTRAINT

$$X_m = 18.2''$$

WORST CASE FOR ENGINE EXTENSION:

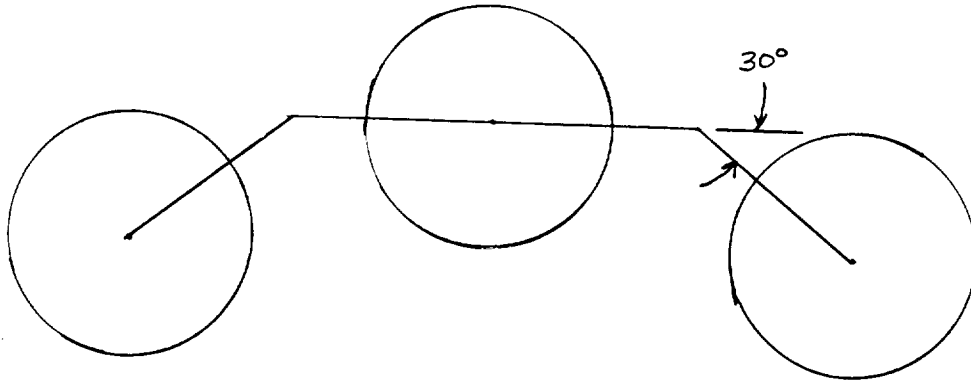

SOLVE WITH METHOD USED IN PART 1.)

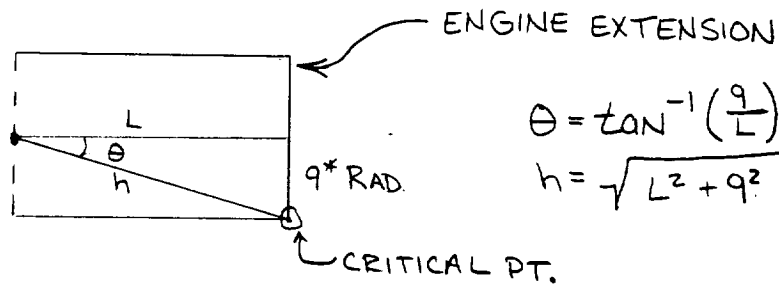

$$\theta = \tan^{-1}\left(\frac{q}{L}\right)$$

$$h = \sqrt{L^2 + q^2}$$

DEFLECTION OF CRITICAL PT.
AT ROTATION:

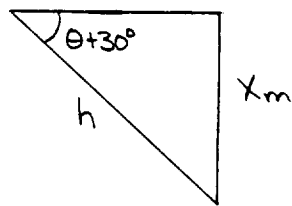

$$\sin(\theta + 30^\circ) = \frac{X_m}{h}$$

$$\sin\left[\tan^{-1}\left(\frac{q}{L}\right) + 30^\circ\right] = \frac{18.2}{\sqrt{L^2 + q^2}}$$

USE MATHCAD TO SOLVE:

$$\underline{L = 20.81''}$$

CONCLUSIONS:

- COULD USE $L = 20.81''$
FOR LENGTH OF ENGINE EXTENSION.
- DECIDED TO USE $L = 20''$ TO REDUCE WEIGHT AND MATERIAL USED. ALSO SATISFIES BOTH REQUIREMENTS.

MANUFACTURER REFERENCES

Clampco Products, Inc. (216) 336-8857
145 Rainbow Street
Wadsworth, OH 44281

Eder Flagpole Co. (800) 558-6044
Oak Creek, WI

Robert Wagner Flag Sales (800) 842-3524
Elverson, PA

REFERENCES

- Aluminum Construction Manual**. New York: The Aluminum Association, 1959.
- Chamis, C.C., ed. **Structural Design and Analysis**. New York: Academic Press, 1975.
- "Effect of Service Environment on Composite Materials", Neuilly sur Seine, France (North Atlantic Treaty Organization), 1980.
- Feuerbacher, B. et al. **Materials Sciences in Space**. New York: Springer-Verlag, Inc., 1986.
- Fuller, James. **Computer-Aided Engineering Drawing: Using AUTOCAD**. Albany: Delmar Publishers, 1989.
- McGill, David J. and King, Wilton W. **Engineering Mechanics: Solids**. Boston: PWS-KENT Publishing Company, 1989.
- Mischke, Charles R., and Shigley, Joseph Edward. **Mechanical Engineering Design**. New York: McGraw-Hill Book Company, 1989.
- Popov, Egor P. **Introduction to Mechanics of Solids**. Englewood Cliffs, NJ: Prentice-Hall, Inc., 1968.
- Vinson, J.R., ed. **Emerging Technologies in Aerospace Structural Dynamics and Materials**. New York: American Society of Mechanical Engineers, 1980.
- Vinson, J.R., ed. **Modern Developments in Materials and Structures**. New York: American Society of Mechanical Engineers, 1979.

ACKNOWLEDGMENTS

Group One acknowledges the assistance of several individuals and companies through the duration of our project. We would like to thank Dr. Georges Fadel for his assistance with the solid modeling. We would also like to thank Eder Flagpole Company for their information on aluminum pole fabrication.

Special appreciation is extended to Dr. Lawrence Jacobs of the department of Engineering Science and Mechanics and Craig Campbell. We thank Mr. James Brazell for his valuable insight and guidance. I would personally like to thank the group members who cooperated so well and worked tirelessly to assemble this presentation. .

Jason Scott Dell
Thomas Bayne Meeks
Brent Nelson
Thomas Winchell