

141628

Conceptual Design of a Fleet of Autonomous Regolith Throwing Devices for Radiation Shielding of Lunar Habitats Supplemental Report

P-41

Submitted to:

Mr. Dennis Wells
Automation and Robotics Division
Universities Space Research Association (USRA)
National Aeronautics and Space Administration (NASA)
Johnson Space Center, Houston, Texas

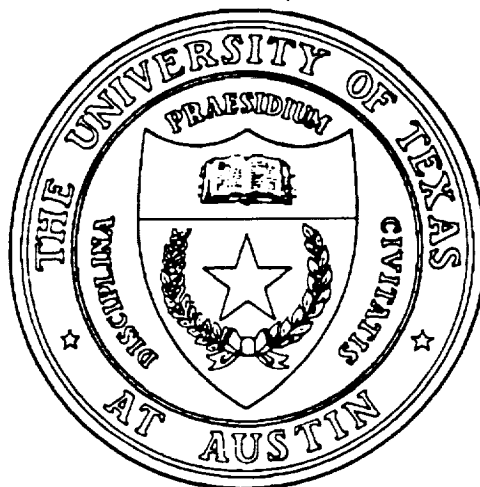

N93-18018

Unclas

G3/54 0141628

Prepared By:

Karem Armstrong
Daniel A. McAdams
Jeffery L. Norrell (Team Leader)

Mechanical Engineering Department
The University of Texas at Austin
Austin, Texas

Spring 1992

(NASA-CR-192030) CONCEPTUAL DESIGN
OF A FLEET OF AUTONOMOUS REGOLITH
THROWING DEVICES FOR RADIATION
SHIELDING OF LUNAR HABITATS
Supplemental Report (Texas Univ.)

41 p

**CONCEPTUAL DESIGN OF A FLEET OF AUTONOMOUS REGOLITH
THROWING DEVICES FOR RADIATION SHIELDING OF LUNAR HABITATS
SUPPLEMENTAL REPORT**

Submitted to:

Mr. Dennis Wells
Automation and Robotics Division
Universities Space Research Association (USRA)
National Aeronautics and Space Administration (NASA)
Johnson Space Center, Houston, Texas

Prepared By:

Karem Armstrong
Daniel A. McAdams
Jeffery L. Norrell (Team Leader)

Mechanical Engineering Department
The University of Texas at Austin
Austin, Texas

Spring 1992

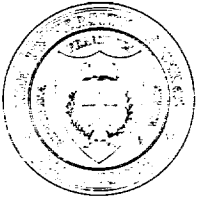

MECHANICAL ENGINEERING DESIGN PROJECTS PROGRAM

THE UNIVERSITY OF TEXAS AT AUSTIN

ETC 4.102 • Austin, Texas 78712-1063 • (512) 471-3900 • FAX (512) 471-7682

April 29, 1992

Mr. Dennis Wells
Automation and Robotics Division
LBJ Space Center / NASA
Houston, TX 77058

Dear Mr. Wells:

Attached is a copy of the supplemental report for the design project entitled "Conceptual Design of a Fleet of Autonomous Regolith Throwing Devices for Radiation Shielding of Lunar Habitats". A more thorough investigation of the design presented in our final report sent to you on April 13, showed that some refinement was needed in the traction required by the device and the stability of the device when throwing the regolith. This supplemental report addresses these issues.

The first section of the supplemental report presents an evaluation of the critical areas of the design and presents alternative solutions to refine these areas. The next section presents the selected solutions. To prevent inadequate traction, the depth of dig per pass is reduced. A method combining a dynamic counterweight and an outrigger is chosen to provide a stable device.

The team has enjoyed working on this project. We appreciate all the help and information you gave us and we look forward to seeing you at the final design presentation. This presentation will take place on Friday, May 1st, 1992, at The University Space Research Association in Houston, Texas. We currently don't know the exact time or location for the presentation. We will notify you as soon as we get more details.

Sincerely,

A handwritten signature in black ink that reads "Karem Armstrong". The signature is written in a cursive style and is enclosed in a hand-drawn oval.

Karem Armstrong

A handwritten signature in black ink that reads "Daniel A. McAdams". The signature is written in a cursive style.

Daniel A. McAdams

A handwritten signature in black ink that reads "Jeffery L. Norrell". The signature is written in a cursive style.

Jeffery L. Norrell (Team Leader)

TABLE OF CONTENTS

	PAGE #
TABLE OF CONTENTS.....	ii
LIST OF FIGURES.....	iii
1.0 INTRODUCTION.....	1
2.0 ALTERNATIVE SOLUTIONS.....	2
2.1 Traction	2
2.1.1 Alternative Traction Solutions	3
2.1.1.1 Reduced Depth of Dig Per Pass.....	3
2.1.1.2 High Traction Wheel Tread.....	3
2.2 Stability	3
2.2.1 Modifications to Configuration #1	5
2.2.1.1 Outrigger	5
2.2.1.2 Anchor.....	6
2.2.1.3 Dynamic Counterweight.....	8
2.2.1.4 Recoilless	10
2.2.1.5 Added Mass	10
2.2.2 Alternative Configurations	10
2.2.2.1 Configuration #4	11
2.2.2.2 Configuration #5	12
3.0 SELECTED SOLUTIONS.....	14
3.1 Traction Solution	14
3.2 Stability Solution	15
4.0 CONCLUSION	16
APPENDICES	
Appendix N Outrigger Solution for Stability	N1
Appendix O Anchor Solution for Stability	O1
Appendix P Dynamic Counterweight Solution for Stability...	P1
Appendix Q Alternative Configurations for Stability	Q1
Appendix R Combination Solution for Stability.....	R1

LIST OF FIGURES

FIGURE #		PAGE #
1.	Direction of instability of current design configuration.....	4
2.	Outrigger configuration	6
3.	Anchor configuration.....	7
4.	Dynamic counterweight configuration.....	8
5.	Configuration # 4.....	11
6.	Configuration # 5.....	13
01.	Diameter vs. depth of anchor.....	03
P1	Configuration of dynamic counterweight.....	P2
Q1	Outrigger length vs. launch height	Q4
R1	Required counterforce vs. outrigger length.....	R3

INTRODUCTION

This report presents refinements in two areas of the initial design presented in the report entitled "Conceptual Design of a Fleet of Autonomous Regolith Throwing Devices for Radiation Shielding of Lunar Habitats". The first section presents an evaluation of the critical areas of the design and presents alternative solutions for these areas. The areas for design refinement are the traction required by the device and the stability of the device when throwing regolith. Several alternative methods are presented to solve these problems. First, the issue of required traction is covered. Next, the design is refined to provide a more stable device. The issue of stability is addressed both by presenting solutions for the configuration chosen for the computer simulation and by presenting two more device configurations.

The next section presents the selected solutions. To prevent inadequate traction, the depth of dig per pass is reduced. A method combining a dynamic counterweight and an outrigger is chosen to provide a stable device.

ALTERNATIVE SOLUTIONS

The evaluation of the design chosen for the computer simulation shows the need for refinement in two areas. One of these issues is the traction the device requires. The scraping method for gathering regolith requires the device to generate high traction forces. The traction analysis is presented in Appendix J of the main report. The second area that requires refinement is the stability of the device. The high acceleration required to throw the regolith makes the device unstable. These aspects of the design are refined in the following sections.

2.1 Traction

One of the critical areas of the design configuration is the method of regolith collection. The scraping method chosen for the configuration used in the computer simulation generates a high cutting force of 400 N. The device must develop a traction force greater than the cutting force or the device will not be able to move forward and gather regolith. Because the device is lightweight, the traction generated by the device is small. Using the current configuration the device generates 400 N of traction. With a generated traction of 400 N and a cutting force of 400 N the net traction is zero. The current configuration provides no additional traction to permit the device to climb slopes and handle unexpected terrain.

2.1.1 Alternative Traction Solutions

2.1.1.1 Reduced Depth of Dig Per Pass. One alternative to increase the net traction is to decrease the depth of dig per pass. The cutting force required for the device can be reduced by decreasing the depth of dig made by the scraper in each pass. Decreasing the depth of dig either increases the time to complete the job or requires the device to move at a faster rate to complete the job in one lunar day. Decreasing the depth of dig per pass to 2.5 cm reduces the cutting force to 290 N thus providing adequate generated traction for inclines and other high traction requirements. However, when the depth of dig per pass is reduced to 2.5 cm, the linear velocity of the device doubles if the job is still to be completed in one lunar day.

2.1.1.2 High Traction Wheel Tread. Another possible solution to accommodate high traction requirements is the use of a high traction tread on the wheels. The calculations performed to investigate the generated traction force do not take into consideration different wheel tread patterns. A high traction tread pattern can solve traction requirements generated by the scraping method for gathering regolith.

2.2 Stability

The second critical area that needed refinement is the device stability. The current configuration is unstable when it throws the regolith. The direction of instability of the current design is in the direction opposite to the throw, as shown in Figure 1. The stability of the device is affected by a number of

factors including the large acceleration used to launch the regolith, the low device mass, and the high launch position of the regolith with respect to the center of mass of the device.

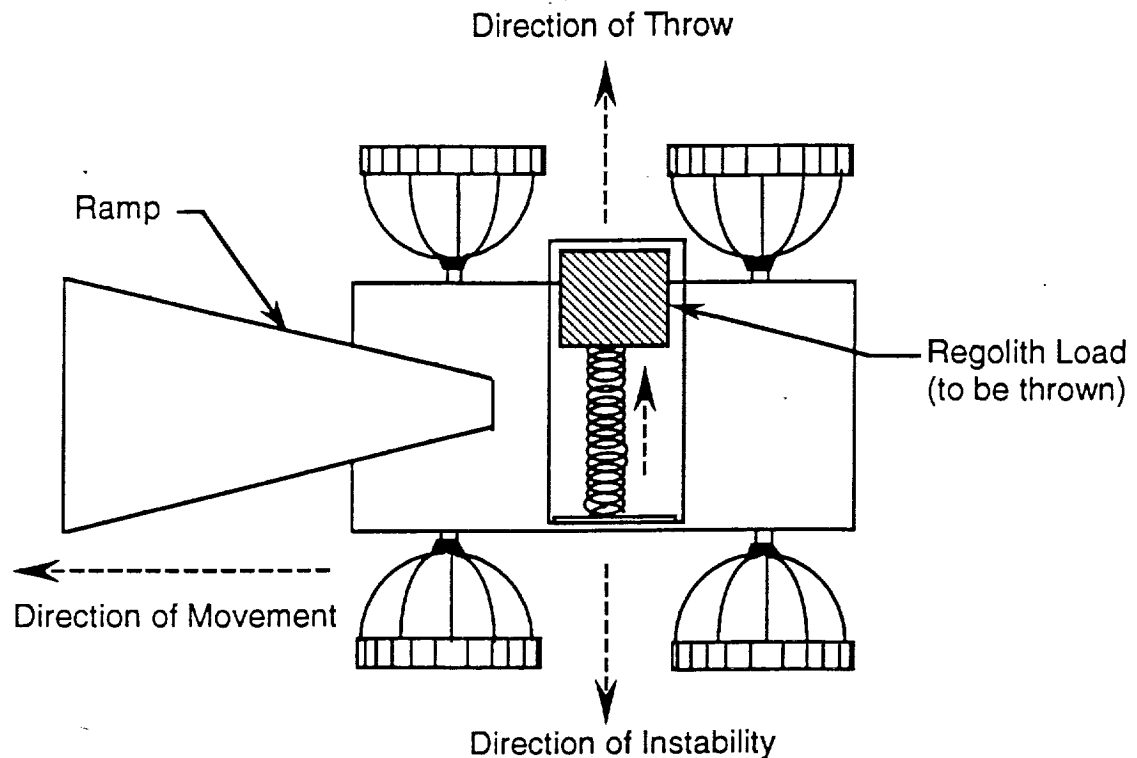

Figure 1. Direction of instability of current design configuration

There are several reasons for covering device stability in more detail than the problem of inadequate traction. One reason is that, as discussed above, the solutions to inadequate traction have little effect on the device configuration. Also, stability is a critical area. If the device falls over it will be unable to complete the task of covering the habitat. Although the device could be designed to right itself after tipping, it is more direct to design a device that is stable when throwing regolith. Another reason for a more in depth

investigation is that increased stability solutions require greater modification of the selected configuration. Also, the methods to increase device stability are less obvious than the methods to increase net traction. Because the device presented in the main report is unstable in its current configuration, stability is the more critical of the areas refined.

This section presents methods to stabilize the device when regolith is thrown. Two approaches are used. The first is to find solutions, such as supports or anchors, to stabilize the chosen configuration. The second approach is to choose a configuration that, because of device arrangement, provides a more stable device.

2.2.1 Modifications to Configuration #1

This section presents methods to stabilize configuration #1 of the main report. The solutions presented are an outrigger, an anchor, a dynamic counterweight system, a recoilless, and an increased device mass.

2.2.1.1 Outrigger. One method to provide a stable device is to equip the device with an outrigger, as shown in Figure 2. The outrigger provides the needed leverage to make the device stable. An advantage of using an outrigger is that it has little effect on the device as it is designed. The arrangement of the gathering method and the launch mechanism remain the same if an outrigger is added to the device. Also, parameters such as time per throw and size of throw will not be changed by adding an outrigger. However, using an outrigger presents several disadvantages. Analysis shown in Appendix N shows that the outrigger needs to be approximately 8.3 meters long.

Considering that the device is only one meter wide, providing it with an eight meter outrigger will be complicated. Also, an outrigger will have to be raised and lowered as the device moves around to gather the regolith. Outrigger movement will add to the general complication of operating the device. Positioning the outrigger will also be a problem if the outrigger encounters obstacles or interferes with the movement and operation of other regolith throwing devices.

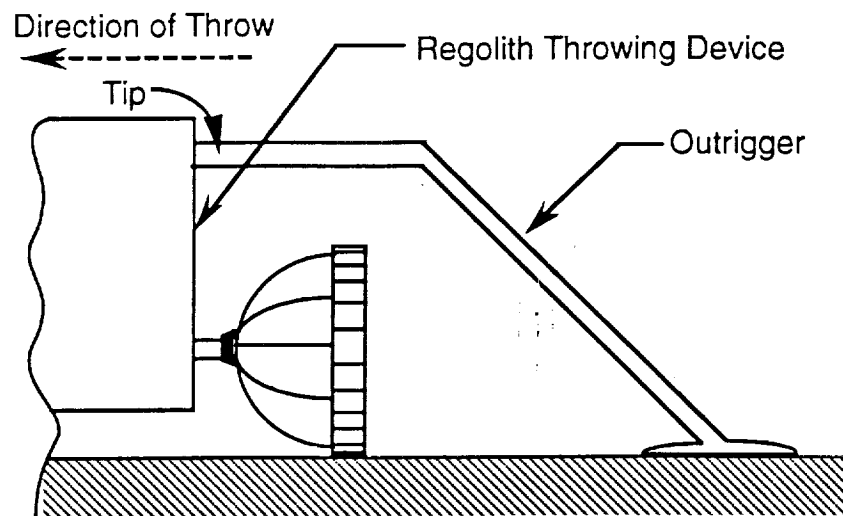

Figure 2. Outrigger configuration

2.2.1.2 Anchor. A second possible solution is to use an anchor to provide device stability. As shown in Figure 3, an anchor is attached to the device. The anchor embeds into the ground while the spring is compacting. Once firmly secured to the ground, the device releases the regolith. The anchor is attached to the side of the device that tips upward as the regolith is thrown. By securing this side to the lunar surface, the anchor provides the necessary

stability for the device. An advantage of the anchor solution is that it is secured near the device, thus occupying a small space and avoiding some of the problems encountered by the outrigger solution. One problem with the anchor solution is the limited data about the lunar surface and regolith. Using an anchor is unsuccessful if there is a high concentration of rocks in the soil.

To provide a secure anchorage, it is necessary to know how deep to sink the anchor. Appendix O presents an analysis of anchor requirements. An anchor embedded 40 cm in the ground will be approximately 1m in diameter. To decrease the anchor diameter to 1/2 m, the anchor is buried 1 m deep. Embedding an object of the required size to the necessary depth in 30 seconds is difficult. Thirty seconds is the cycle time available for each throw. In addition, the anchor must be removed during this cycle.

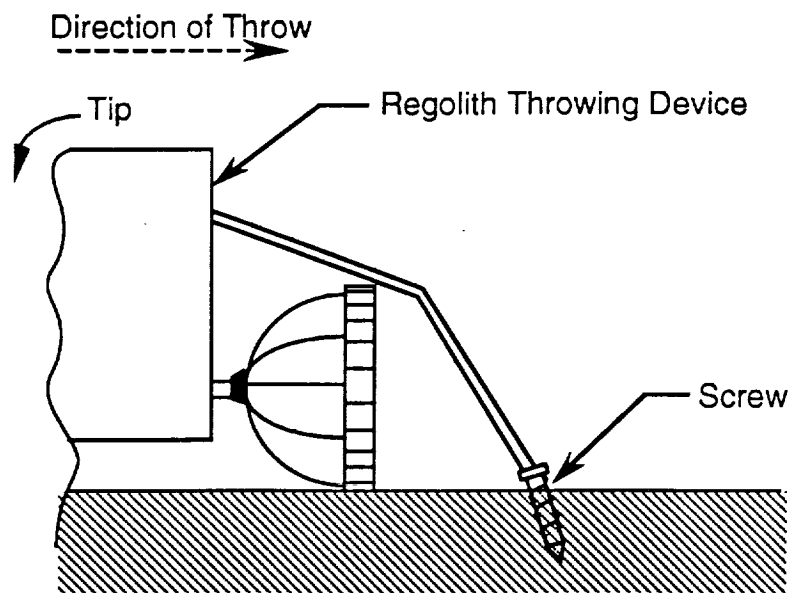

Figure 3. Anchor Configuration

2.2.1.3 Dynamic Counterweight. Another method to stabilize the device is to provide the throwing mechanism with a dynamic counterweight. A dynamic counterweight configuration is shown in Figure 4. The device is unstable because of the high change in momentum caused as the regolith is accelerated quickly and thrown from the device. To counteract the change in momentum, the device will accelerate another mass in the opposite direction.

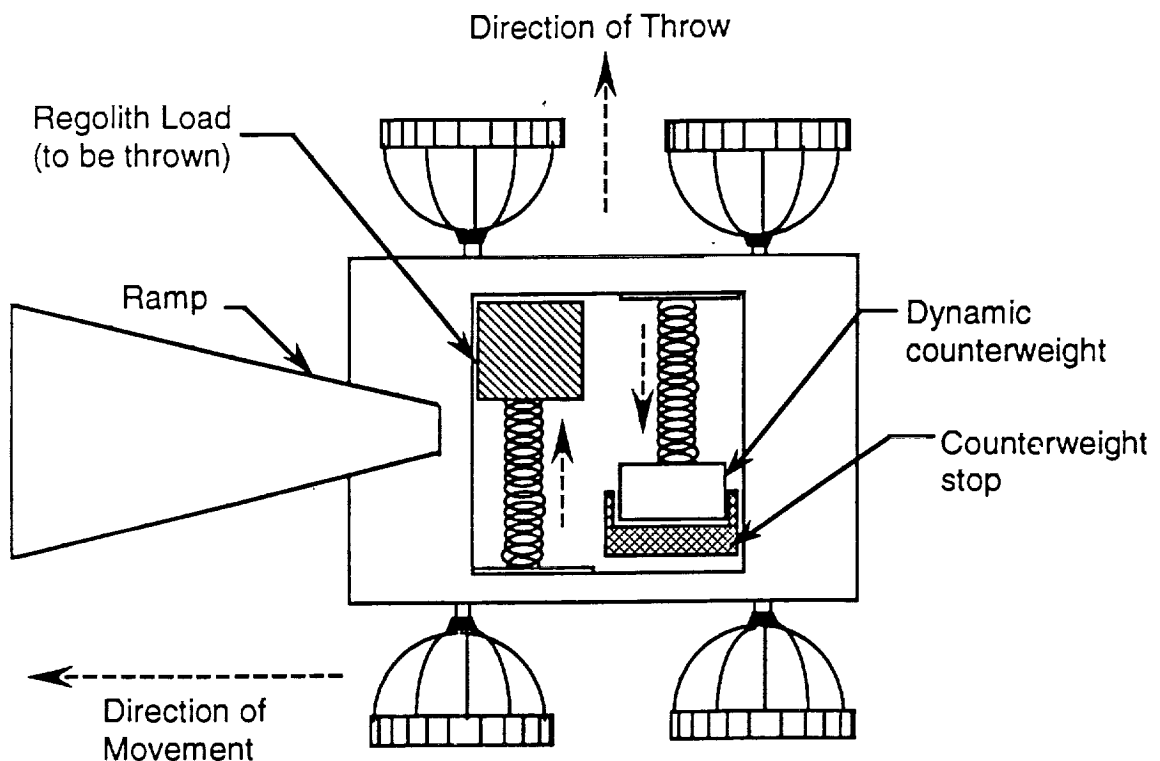

Figure 4. Dynamic counterweight configuration

One variation of the dynamic counterweight alternative is to have the device throw two loads of regolith. One load is thrown onto the habitat and the other is thrown in the opposite direction to neutralize the change in

momentum. A weakness of this solution is that the amount of work required to cover the habitat is almost doubled because the device has to gather and throw twice as much regolith. In addition to gathering and throwing twice as much regolith, the device will have to clear a larger area to gather the extra regolith. Clearing more area requires the device to throw the regolith farther to reach the habitat, thus increasing the energy the device must expend to cover the habitat. Also, covering random objects, including other regolith throwing devices, is undesirable.

Another alternative is to accelerate a dynamic counterweight on the device without releasing it. A mass is accelerated as the regolith is thrown. After the regolith is launched the dynamic counterweight is decelerated slowly to induce a small change in momentum to the device. This procedure does not completely neutralize the momentum generated but it decreases it enough to stabilize the device.

To offset the force caused by the thrown regolith, the dynamic counterweight needs to have an effective force of 3241 N. As shown in Appendix P, it is difficult to provide the required counterforce. The counterweight requires a distance to decelerate after the regolith is thrown from the device. If the deceleration distance is too short, the device will become unstable as the counterweight decelerates. Because the device is only 70 cm wide, it is difficult to accelerate a mass that counter acts the instability caused by the thrown regolith without the device becoming unstable as this mass is decelerated. Another disadvantage is the added mechanical complications of the additional accelerating mechanism and decelerating mechanism.

2.2.1.4 Recoilless. A recoilless is the method used by devices such as artillery to absorb the change in momentum of the gun as the shell is launched. Research into standard recoilless systems shows that they are not suited for lunar applications. Most recoilless system use gas or fluid filled pistons to transmit and absorb recoil energy. Some recoilless systems crush, or destroy, an object to absorb the recoil energy. Both of these solutions are unfeasible on the Moon. The absence of an atmosphere on the Moon causes the fluid or gas to evaporate thus preventing the operation of a piston recoilless. If an object is destroyed to absorb the recoil energy it must be replaced after each launch. Because the each device must make approximately 390 000 throws, providing an object to destroy for each throw is unfeasible.

2.2.1.5 Added Mass. Another method to stabilize the device is to increase the mass of the device. Adding arbitrary mass to the device is an unfeasible solution because of the cost of transporting marginally useful mass to the Moon. An alternative is to load the device down with regolith once it reaches the Moon to increase the effective mass of the device. To be stable, the device would need to carry approximately 3700 kg which is over two cubic meters of regolith. However, increasing the mass of the device is a poor solution because moving the added mass around the lunar surface increases the amount of energy required to operate the device.

2.2.2 Alternative Configurations

Another way to stabilize the device is to construct a new configuration that is inherently stable. Solutions are more stable if the mass is thrown from

a low position on the device. The configurations presented in this supplemental report will not present the layout for functions such as obstacle avoidance and powering. The configurations presented will only illustrate different layouts that increase the stability of the device.

2.2.2.1 Configuration #4. This configuration, shown in Figure 5, uses a launch position very close to the ground to provide a stable arrangement. The launch chamber is loaded by a belly-type scraper positioned close to the ground.

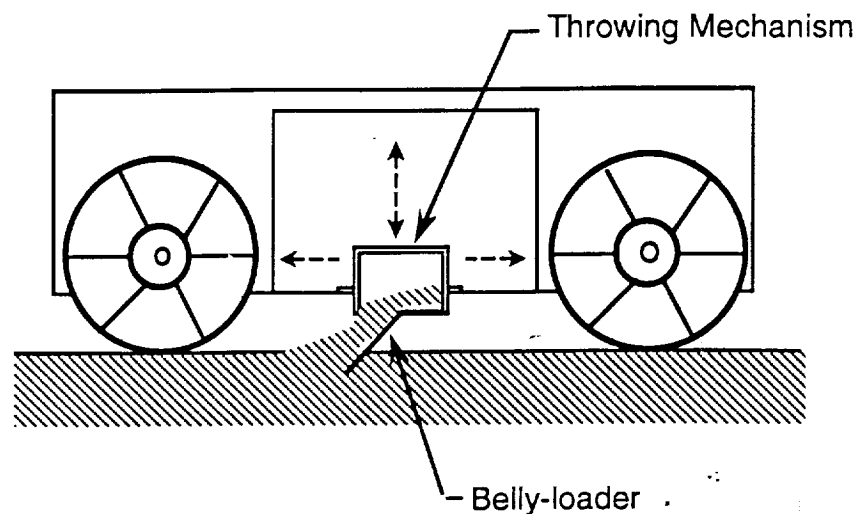

Figure 5. Configuration # 4

This configuration presents several advantages. In this configuration, the launch position is close to the ground. Having the launch position close to the ground reduces the effective lever arm of the launched mass. Reducing the lever arm reduces the tipping torque. Another advantage of this device is that it will require a smaller cutting force to gather regolith. As shown in Appendix J

of the main report, the cutting force is a function of the cutting blade angle and the height of the bucket filled. Positioning the bucket at this location allows the height of the bucket to be lowered and the cutting angle to be decreased. This bucket position reduces the cutting force and thus the required traction.

Although the configuration shown in Figure 5 has several advantages over configuration 1, it does not offer a complete design refinement. A problem with this configuration is that the location of the throwing volume prevents the throwing mechanism from having a full range of freedom. Also, as shown in Appendix Q, to maintain a stable device, the throw position is 2.1 cm above the ground. The volume of the regolith, a cube 20 cm on each side, prevents the execution of this solution.

2.2.2.2 Configuration #5. This configuration, shown in Figure 6, uses a different gathering method and a low launch position to stabilize the device. The significance of the different regolith gathering method is that it doubles as an anchor for the device. In this configuration the gathering method works like a back hoe. After filling the load chamber, the arm is positioned to provide an outrigger for the device. This configuration has several advantages over those presented previously. This regolith gathering method presents a more compact solution than the scraper ramp. Also, problems with required traction are reduced. Another advantage is that the regolith gathering is not dependent on the movement the vehicle. The device can remain in one place and make several throws. Remaining stationary for several throws has the advantage of requiring fewer starts and stops of the device.

This solution has several disadvantages. The arm used to load the device will have to operate at relatively high speeds to load the throwing

receptacle. Another disadvantage of this configuration is the increased mechanical and computational complexity of the back hoe.

Appendix Q contains an analysis of configuration #5. For the device to be stable an effective outrigger length of approximately three meters is needed for a launch height of 20 cm. Twenty centimeters is as low as the launch position can be if the thrown volume of regolith is a cube 20 cms on a side.

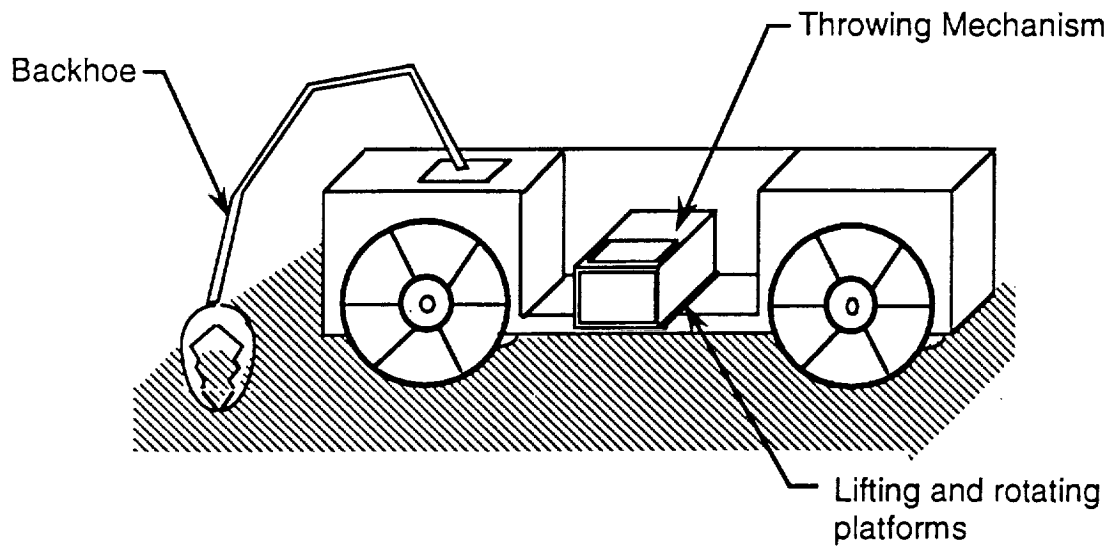

Figure 6. Configuration # 5

SELECTED SOLUTIONS

After comparing the alternative solutions presented above, solutions were selected to refine the design. To prevent inadequate traction, the depth of dig per pass is reduced. A method combining a dynamic counterweight and an outrigger is chosen to provide a stable device.

3.1 Traction Solution

The chosen method to allow for greater net traction is to reduce the depth of dig per pass to 2.5 cm. Changing the depth dig per pass is the preferred method for several reasons. One factor is that the advantage gained by a high traction tread is difficult to determine. Also, because the device moves at a low velocity, doubling the device velocity will effect the system minimally. Doubling the velocity will have no effect on the launch mechanism or cycle time. Also, changing the velocity will have little effect on the device power requirements. The power required to move the device is the force required for movement multiplied be the velocity of movement. Although the velocity is doubled, the force is decreased by a factor of approximately 2. By decreasing the depth of dig per pass, the required power is essentially the same as the configuration presented in the main report.

Because of the conceptual state of the model, the traction analysis performed is a first order approximation. If a more detailed traction analysis shows that the generated traction is acceptable, changing the depth of cut per pass and the tread pattern are done with little effect to the overall design.

Because these changes are easily made, the problem of inadequate traction is easily solved in the next stage of design development.

3.2 Stability Solution

The solution chosen to provide device stability is to use a dynamic counterweight system combined with an outrigger. The decision was based on the effectiveness of the solution, power and energy requirements, mechanical complication, and ease of adding it to configuration #1 of the main report. The analysis presented in this supplemental report and the attached appendices indicate that using one of the alternative solutions by itself is inferior to combining two. The anchor solution is rejected due to the limited information available about the lunar surface. The alternative configurations were rejected, at the present time, because they require an entire new analysis of the system parameters.

The dynamic counterweight works in the following fashion. Before throwing the first volume of regolith, the device will load a receptacle with regolith to serve as a dynamic counterweight. The same regolith will be used as a dynamic counterweight until the task of covering the habitat is completed. The dynamic counterweight has a mass of 20 kg. The dynamic counterweight is accelerated for 55 cm by a spring creating a maximum force of 2767 N. Once the regolith is thrown, the dynamic counterweight regolith will decelerate for 15 cm. An outrigger approximately 1.5 m long is used to provide the additional support to make the device stable. Calculations for the combined solution are presented in Appendix R.

CONCLUSION

The device presented in this supplemental report and the main report entitled Conceptual Design of a Fleet of Autonomous Regolith Throwing Device for Radiation shielding of lunar Habitats, is used to show the feasibility of throwing regolith on the Moon. The two areas of the main design refined in this supplemental report are the generated traction and the stability of the device. The depth of cut per pass is decreased to increase the net traction generated by the device. A dynamic counterweight combined with an outrigger is used to provide device stability. The analysis presented in Appendix R show that this is a very stable device. With the solution outlined, the device will not even rock as the mass is launched. Preventing the device from rocking back and forth is desirable to provide an accurate trajectory to throw the regolith.

APPENDICES

APPENDIX N

OUTRIGGER SOLUTION FOR STABILITY

In this appendix, an outrigger is presented as a solution to provide a stable device. To make the device stable, the outrigger must be 8.31 m long.

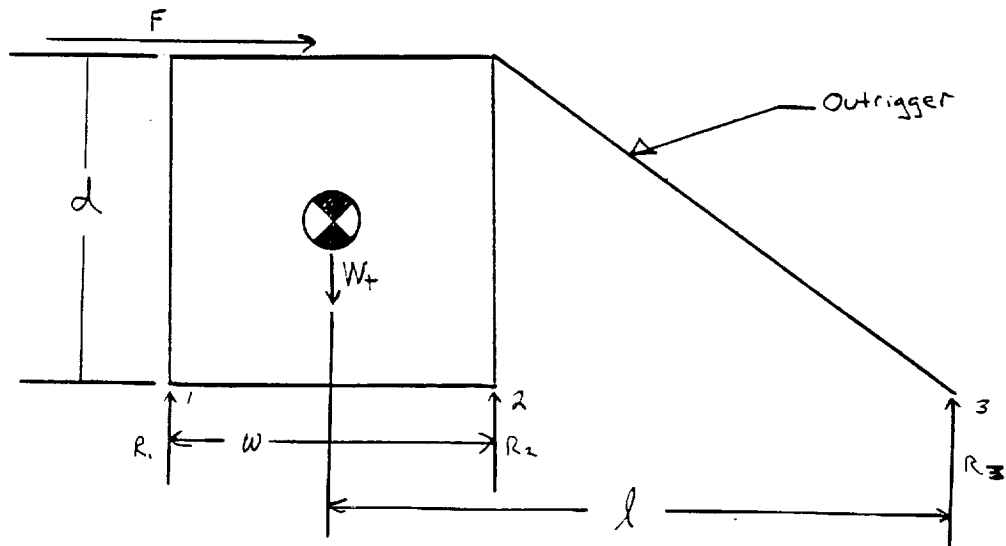

Method:

As the device becomes unstable, it rotates around point 3. Reaction forces R_1 and R_2 go to 0. Model the device as shown above.

Nomenclature:

F = effective force imposed on device by the accelerating mass

d = height of device

w = width of device

l = length of outrigger

W_t = weight of device.

at the moment the device becomes unstable
 $\Sigma M_3 = 0$

$$F d = W_+ l \quad (N1)$$

$$l = \frac{F d}{W_+} \quad (N2)$$

insert values of

$$F = ma = (11.72 \text{ kg})(288 \text{ m/s}^2) = 3375 \text{ N}$$

$$d = .6 \text{ m}$$

$$W_+ = mg = (150 \text{ kg})(1.624 \text{ m/s}^2) = 243.6 \text{ N}$$

into (N2) yields

$$\underline{l = 8.31 \text{ m}}$$

APPENDIX O

ANCHOR SOLUTION FOR STABILITY

In this appendix an anchor is presented as a solution to provide a stable device. The anchor is modeled as a circular plate. To hold the device securely the anchor must be either embedded deeply in the ground or have a large diameter.

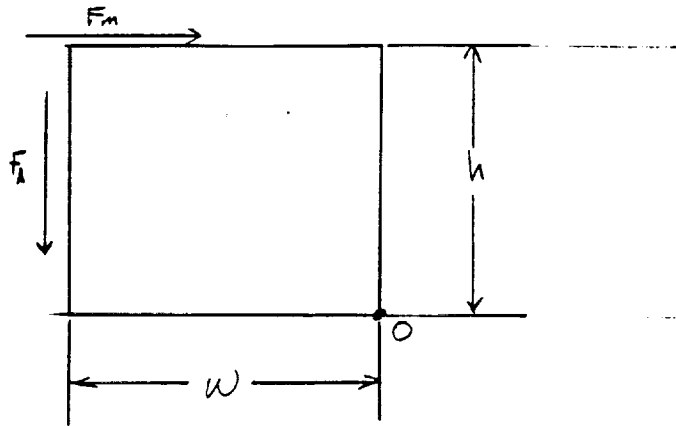
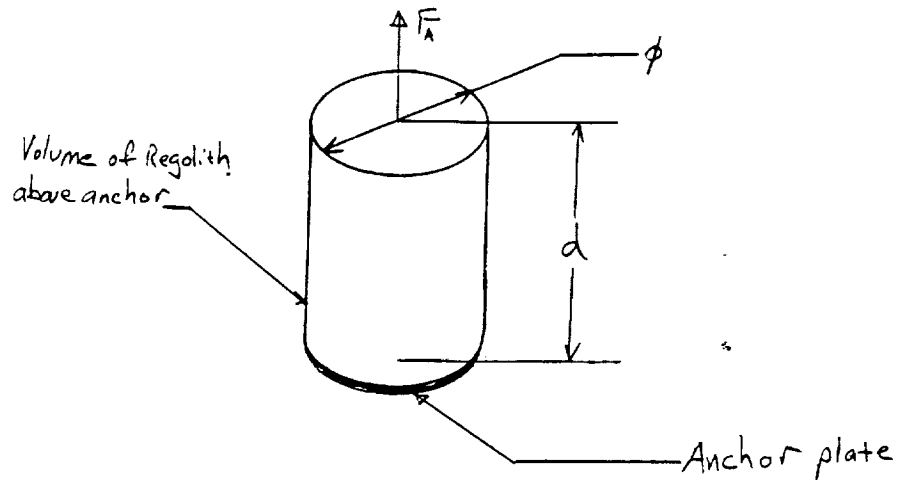

Method:

The force required to remove the anchor from the ground is the weight of the regolith above it added to the shear force required to move the cylinder of regolith. Model the regolith as a circular plate of diameter ϕ buried into the ground a depth d . The moment created by the accelerated mass is to be completely counteracted by the force supported by the anchor.

Nomenclature:

F_m = Force caused by accelerated mass

F_A = Force supported by anchor

ϕ = diameter of anchor

d = depth of anchor burial

w = width of device

h = height of device

V = Volume of regolith

$\tilde{\tau}$ = shear strength of regolith

ρ = density of regolith.

A = surface area which shear force acts on.

Analysis:

$$F_m h = F_A w \quad (01)$$

$$F_A = \frac{F_m h}{w} \quad (02)$$

$$\begin{aligned} F_A &= \tilde{\tau} A + V \rho \\ &= \tilde{\tau} \pi \phi d + \frac{\pi}{4} \phi^2 d \rho \end{aligned} \quad (03)$$

Combine (02) and (03)

$$\frac{F_m h}{w} = \tilde{\tau} \pi \phi d + \frac{\pi}{4} \phi^2 d \rho \quad (04)$$

all values are known except d and ϕ .

Using values of D

$$F_m = 3375 \text{ N}$$

$$\rho = 1465 \text{ kg/m}^3$$

$$h/w = .91$$

$$\tau = 2500 \text{ N/m}^2$$

the following plot is made

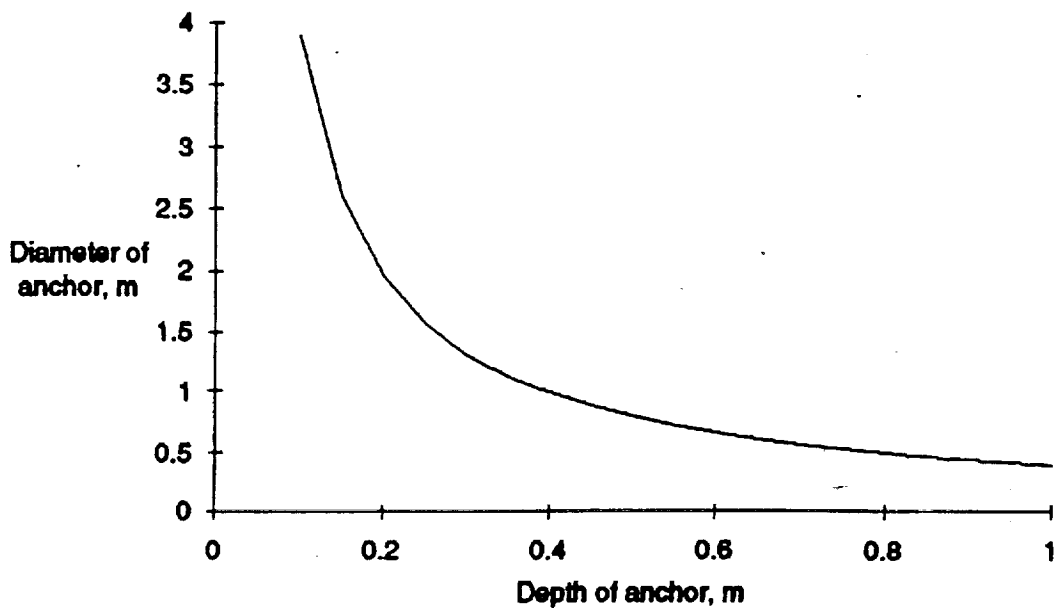

Figure 01. Diameter vs depth of anchor.

This plot shows that if the anchor is buried approximately 1 meter deep, the diameter of the anchor must still be $\frac{1}{2}$ meter in diameter. Also, an anchor depth of .4m requires an anchor diameter of 1m to provide a stable device.

APPENDIX P

DYNAMIC COUNTERWEIGHT SOLUTION FOR STABILITY

In this appendix, a dynamic counterweight is presented as a solution to provide a stable device. To make the device stable the counterweight requires a spring with a spring constant of 60 kN/m.

Dynamic Counterweight solution.

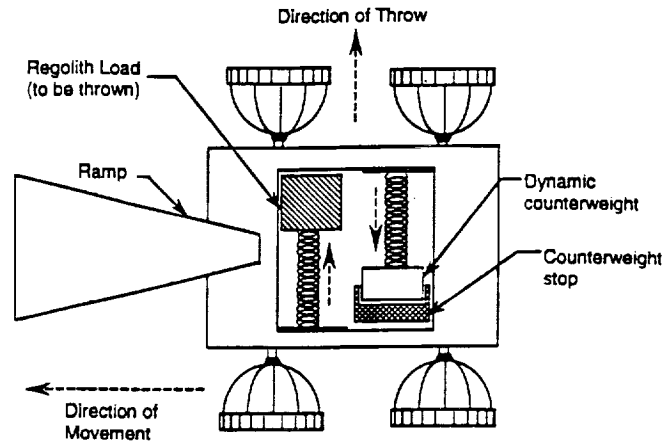

Figure P1. Configuration of dynamic counterweight

Method:

Accelerate a mass in the opposite direction of the one thrown. Decelerate this mass slowly to minimize the change in momentum the device must support.

Nomenclature

- F = maximum force the device can support
- F_m = force accelerated mass exerts on the device
- F_c = force counterweight exerts on the device
- K_c = counterweight spring constant.
- m_c = counterweight mass
- A_{ac} = counterweight acceleration
- A_{dc} = counterweight deceleration.
- X = distance to accelerate and decelerate counterweight
- X_A = distance to accelerate counterweight
- X_S = distance to decelerate counter mass.

v = velocity of counter mass
 F_s = force exerted by slowing mass

Analysis:
for stable equilibrium

$$F_c = F_m - F \quad (P1)$$

$$F_c = k_c X_A = m_c A_c \quad (P2)$$

$$\frac{1}{2} k_c X_A^2 = \frac{1}{2} m_c v^2 \quad (P3)$$

$$v^2 = 2 A_c X_S \quad (P4)$$

Comb (P3) and (P4)

$$\frac{k_c X_A^2}{m_c} = 2 A_c X_S \quad (P5)$$

$$F_s = m_c A_c \quad (P6)$$

Substitute (P2) and (P5) into (P6) yields

$$F_c X_A = 2 F_s X_S \quad (P7)$$

$$X = X_A + X_S \quad (P8)$$

$$F_s = F \quad (P9)$$

rewrite (P5)

$$m c A a c x_A = 2 m c A s c x_s \quad (P10)$$

let $x = .7$

so

$$x_A + x_s = .7$$

$$F_c x_A = 2 F_s (.7 - x_A) \quad (P11)$$

$$F_c = 3241$$

$$F_s = 134$$

yields

$x_A = .05m$ which requires a spring constant
of 50 dyn/cm.

Also - acceleration analysis is not accurate for such
small acceleration distances.

APPENDIX Q

ALTERNATIVE CONFIGURATIONS FOR STABILITY

In this appendix, two alternative configurations are presented as solutions to provide a stable device. To make the device stable the launch height must be less than 0.021 m. When combining an outrigger and a low launch position of 0.20 cm the outrigger must be three meters long.

Configuration Solution: Reduce throw height.

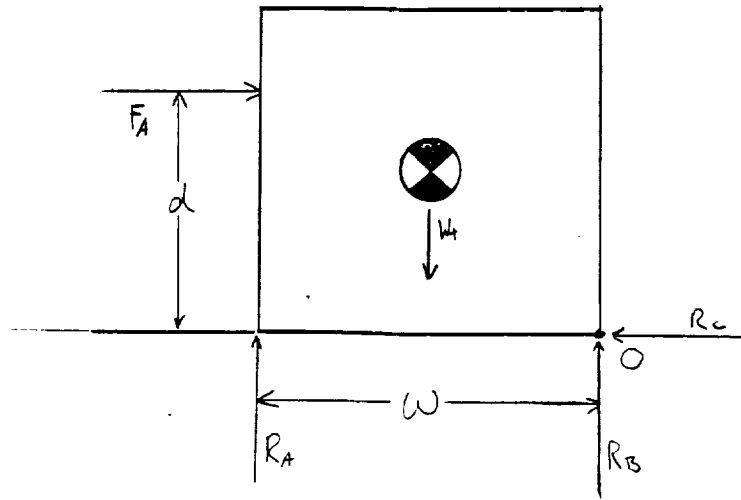

Method:

Reduce the launch position so that the lever arm, d , is short enough to not create an unstable device.

Nomenclature:

F_A = force caused by accelerated mass.

W_t = weight of device

R_n = Reaction forces

ω = width of device

d = height from which regolith is thrown.

Analysis:

$$\sum M_o = 0$$

$$\left(\frac{1}{2}\omega\right)W_t - Fd = 0$$

(Q1)

Rearrange (Q1) for d yields

$$d = \frac{(\frac{1}{2}\omega)W}{F}$$

using values of

$$F = 3375 \text{ N}$$

$$W = 150 \text{ kg} \times 1.624 \text{ m/s}^2$$

and solving for different values of d with different values of ω .

ω, m	d, m
.6	.021
1	.03
1.5	.05
2	.07

Table Q1 d as a function of ω .

Configuration which uses backhoe type gathering method. Able to use both a low launch position and then use the back hoe mechanism as an outrigger.

From equilibrium.

$$l = \frac{Fd}{Wt} \quad (Q2)$$

using values of $Wt = 243.6 N$
 $F = 3375 N$

the following plot is made to show the required geometry, to provide a stable device.

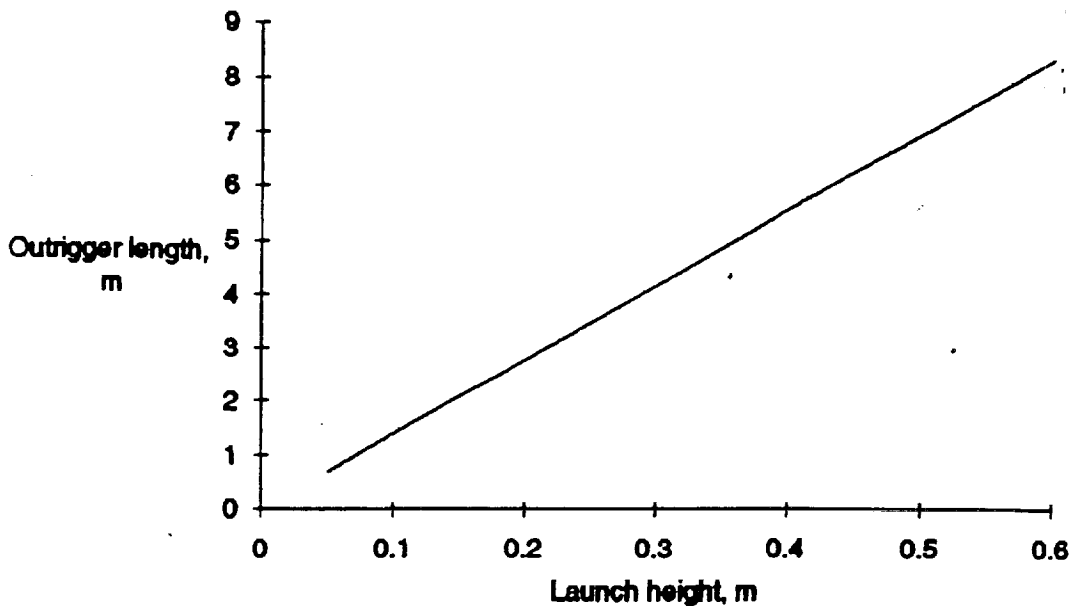

Figure Q1. Outrigger length vs launch height.

APPENDIX R

COMBINATION SOLUTION FOR STABILITY

In this appendix, an outrigger and a dynamic counterweight system are combined to provide a stable device. To make the device stable, the outrigger must be 1.5 m long when combined with a dynamic counterweight system. The dynamic counterweight system has a mass of 20 kg. The dynamic counterweight creates a counterforce of 2767 N.

Combine Solution of Outrigger and Counterweight

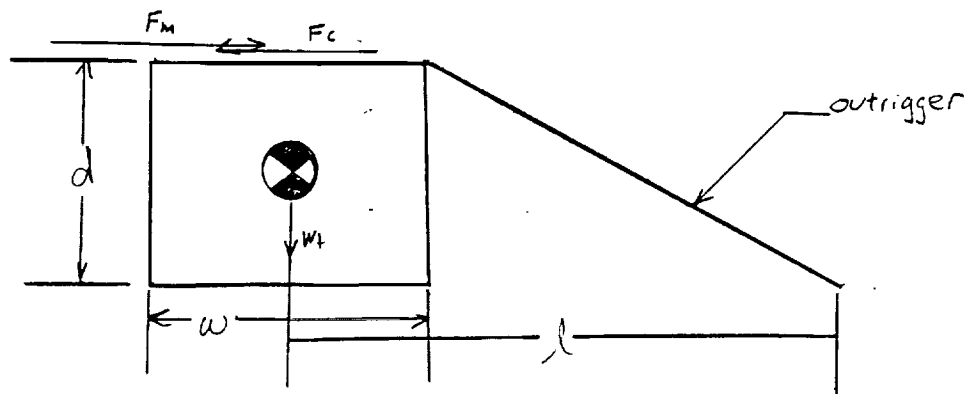

Method:

Combine the outrigger and the counterweight to make the system stable. Note that the outrigger allows the deceleration force of the counterweight to be greater.

Nomenclature:

- F = maximum force the device can support
- F_m = force accelerated mass exerts on device
- F_c = force counterweight exerts on the device
- k_c = counterweight spring constant
- m_c = counterweight mass
- A_{ac} = counterweight acceleration
- A_{dc} = counterweight deceleration
- x = distance to accelerate and decelerate counterweight
- x_A = distance to accelerate counterweight
- x_S = distance to decelerate counterweight
- v = velocity of counterweight
- F_S = Force exerted by decelerating counterweight
- l = length of outrigger.

$d =$ height from which weight is thrown

Analysis:

From equilibrium at tip around outrigger.

$$-F_m d + F_c d + W_t l = 0$$

F_m , d and W_t are known constants.

The following plot is made for what are considered reasonable outrigger lengths. Reasonable outrigger lengths are those less than twice as long as the device is wide.

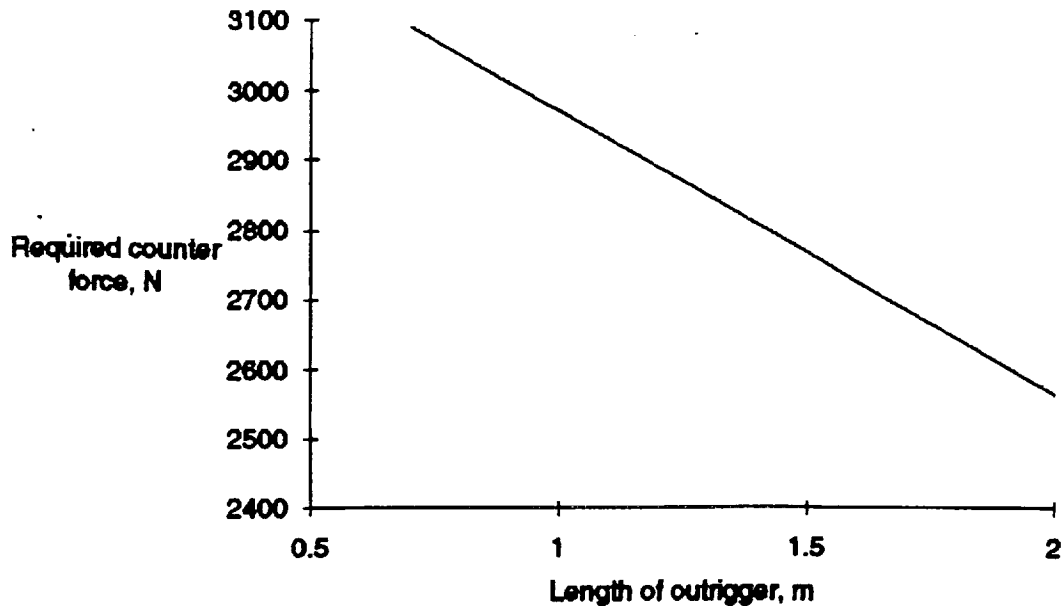

Figure R1. Required counter force vs Outrigger length

All points on the curve in Figure R1 provide for a stable device.

Using an outrigger of 1.5 m in length reduces the required counter force to 2767 N.

Using equation (P7) from appendix P.

$$F_c X_A = 2 F_s X_s \quad (R1)$$

$$F_c X_A = 2 F_s (1.7 - X_A) \quad (R2)$$

$$F_c = 2767 \text{ N}$$

$$F_s = 608 \text{ N}$$

$$X_A = 0.55 \text{ m}$$

$$X_s = 1.15 \text{ m}$$

assume $m_c = 20 \text{ kg}$

$A_H = 138.35 \text{ m/s}^2 \rightarrow$ spring induced.

$A_c = 30.4 \text{ m/s}^2 \rightarrow$ linear damper or spring.