

N93-1235  
IN-33-2R  
146047

**CHARACTERIZATION AND SNUBBING OF A BIDIRECTIONAL MCT  
IN A RESONANT AC LINK CONVERTER**

Tony Lee

Malik E. Elbuluk\* Donald S. Zinger  
Department of Electrical Engineering  
University of Akron  
Akron, OH 44325-3904  
Phone (216) 972-7649  
FAX (216) 972-6487

P-9

**ABSTRACT**

The MOS-Controlled Thyristor (MCT) is emerging as a powerful switch that combines the better characteristics of existing power devices. This paper presents a study of switching stresses on a the MCT switch under zero voltage resonant switching. The MCT is used as a bidirectional switch in an ac/ac pulse density modulated inverter for induction motor drive. Current and voltage spikes are observed and analyzed with variations in the timing of the switching. Different snubber circuit configurations are under investigation to minimize the effect of these transients. The results of this work will be extended to study and test the MCT switching in a medium power (5 hp) induction motor drive.

\* Correspondence Author

(NASA-CR-192230) CHARACTERIZATION  
AND SNUBBING OF A BIDIRECTIONAL MCT  
IN A RESONANT AC LINK CONVERTER  
(Akron Univ.) 9 p

N93-20258

Unclass

G3/33 0146047

# CHARACTERIZATION AND SNUBBING OF A BIDIRECTIONAL MCT IN A RESONANT AC LINK CONVERTER

## DIGEST

### 1. INTRODUCTION

#### A. Background

The recent development of new hybrid power semiconductor devices such as the Insulated-Gate Bipolar Transistor (IGBT) and the MOS-Controlled Thyristor (MCT) have lead to devices that combine the power handling capability of bipolar junction transistors and the fast switching characteristics of power MOSFETs. In particular the MCT, a newly emerging device that combines the high current density and ruggedness of a thyristor with the ease of control of a MOS gate promises to be the promising power switch for the next decade. Though the fabrication and development of the MCT as a bidirectional switch is slowly coming up, device when fully developed will probably dominate high power applications. Researchers continue to develop the static and dynamic characteristics of the MCT [1]-[5].

#### B. Contribution of this paper

This paper addresses the issues related to a practical application of the MCT device in a resonant ac link converter [6]. Because of the ac characteristics bidirectional switches are required. Since the presently available MCT has only forward blocking capability, a bidirectional switch is implemented with MCTs and diodes as shown in the circuit of figure 1. The circuit is an ac resonant link for 3-phase PDM converter for induction motor drive. In order to keep the devices operating in their SOA, snubber circuits are used and improvement in stresses are observed. In particular, snubber circuits different from the conventional ones are designed for these ac/ac converters. In an effort to obtain an optimum snubber, different circuits are under investigation and will be presented. The results are extended to the design and implementation of an MCT, (5 hp) 1-F to 3-F induction motor drive using PDM technique .

### 2. THE PROPOSED CIRCUITS

#### A. The snubber circuits

The 1-phase ac/ac converter of figure 2 consists of two bidirectional switches. From previous work [6], it was found that the turn-off delay of the device causes a current shoot-through which might constitute damage at higher power levels. Previously the shoot-through was avoided by delaying turn-on of the incoming switch and adding a snubber capacitor across each switch (see

figure 3(b)). In addition, the capacitor can cause large voltage spikes across the device during turn-off. As a dual of the conventional snubber, an inductor in parallel with a freewheeling diode as shown in figure 3(a) is employed. This snubber guarantees that no current shoot through the devices and the major power loss of the snubber is in the freewheeling diodes. In addition, because the turn-on signal does not have to be delayed, the gate control circuit is easier to implement. The impedance of the snubber inductor should be small compared to the load so that the voltage drop across the inductor becomes insignificant.

In most applications, loads are inductive and load current has to be continuous. The proposed snubber circuit in figure 3(a) might not be as ideal because the inductor being in series with the load would cause a reduction in the current response. By combining figures 3(a) and 3(b), the snubber circuit shown in figure 3(c) has improved characteristics because the capacitor allows continuous current at turn-on and current can not shoot through the devices.

#### **B. The gate drive circuit**

It was found from an early experiment that the device could be damaged by a gate signal a slow rise time. A safe rise time is found to be around 200ns ~ 250ns. The static capacitance measured at the gate input is about 0.9 $\mu$ F; therefore each switch has about 1.8 $\mu$ F. Theoretically, the gate drive circuit should be able to supply a high current. For a gate voltage swing from -10V to +15V the gate drive circuit needs more than what small signal devices can handle. The gate drive circuit shown in figure 4 consists of power BJTs at the output stage so that the gate current is supplied by both of the collectors of the power BJTs and the emitters of the small signal BJTs. With this circuit rise times closer to 200 ns were obtained which guarantee a safe switching of the device.

### **3. EXPERIMENTAL WORK**

To study the turn on and turn off characteristics of an MCT, a simple dc/dc converter with an inductive load and a turn-off snubber was built. The MCT ratings are 600 V and 60 A. A few MCTs were damaged during this early experiment. Later it was found that in order to switch an MCT without damage, the drive voltage should have a fast rise time. Therefore, the gate drive circuit of figure 4 is designed and built for each MCT.

The ac/ac converter of figure 2 was built using two MCT switches. A Mapham inverter [7] was used as a 20KHz voltage source for this ac/ac converter. The output voltage was modulated to 4KHz. Since the load is inductive, it is represented by a low frequency current source as compared to the 20 kHz input. figure 5 shows the idealized control timing and the output

voltage and current and figure 6 shows the experimental waveforms corresponding to the load voltage and current.

Ideally in this configuration the devices switch at zero voltage with one switch turns on the other turns off. Conventionally, to prevent shoot through, the switch turning on is often delayed and a capacitor is required to keep the current continuous during turn on. This approach has been applied to similar circuits using IGBTs [6]. At high power this could create large voltage spikes that could damage the device. Experimentally with a 20kHz source of 90v pp the turn on was delayed to about 4  $\mu$ s. Under this condition voltage spikes caused damage to the MCTs with switching currents as low as 1.5A. Although a delay of 4  $\mu$ sec seems awfully high, it is introduced here to show the potential voltage spikes that will occur with a small delay in a high power circuit.

To observe the effect of shoot through on the device, the turn-on was advanced to have up to 4 $\mu$ s period in which both switches are on. Without any snubbing on the devices, current spikes of about 12A occurred (see figure 7) but it did not constitute any damage to the devices. A simple snubber circuit consisting of a diode parallel with a 50  $\mu$ H inductor was used to prevent current shoot-through as shown in figure 3(a). It was found that the current spikes were reduced to about 1.5A as shown in figure 8 and the voltage drop across the inductor was significantly small.

The full paper will discuss details of these experimental results along with results of switching at higher power levels.

## REFERENCES

- [1] Frank Goodenough, "A New Breed of Power Switch," *Electronic Design*, November, 1988,
- [2] Harris Semiconductor Inc. "User Guide to MCTs," 1989.
- [3] T.M. Jahns, R.W. De Doncker, J.W.A Wilson, V.A.K. Temple and D.L. Watrous, "Circuit Utilization Characteristics of MOS-Controlled Thyristors," *Proceedings of the IEEE Industry Applications Society*, Oct. 1989, pp. 1-6.
- [4] R.W. De Doncker, T.M. Jahns, A.V. Radun, V.A.K. Temple and D.L. Watrous, "Characteristics of MOS-Controlled Thyristors under zero voltage soft-switching conditions," *Proceedings of the IEEE Industry Applications Society*, Oct. 1989, pp. 1-6.
- [5] C. Braun, "Circuit-Level Modeling of MOS Controlled Thyristors," *Proceedings of the 19th Power Modulator Symposium*, 1990, pp. 436-440.
- [6] S.K. Sul, F. Profumo, G.H. Cho and T.A. Lipo, "MCTS and IGBTs: A Comparison of Performance in Power Electronic Circuits," *IEEE PESC '89 Record*, June 1989, pp 163-169
- [7] N. Mapham, "An SCR Inverter with Good Regulation and Sine-Wave Output", *IEEE Trans. on Ind. Gen. Application*, Vol. IGA-3, Mar./Apr. 1967, pp. 176-187.

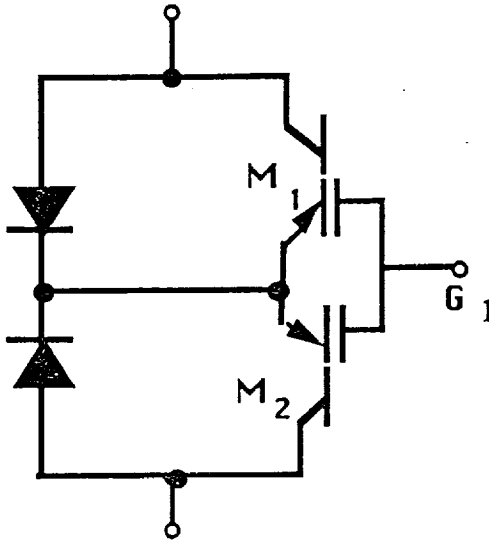

Figure 1 MCT bidirectional Switch

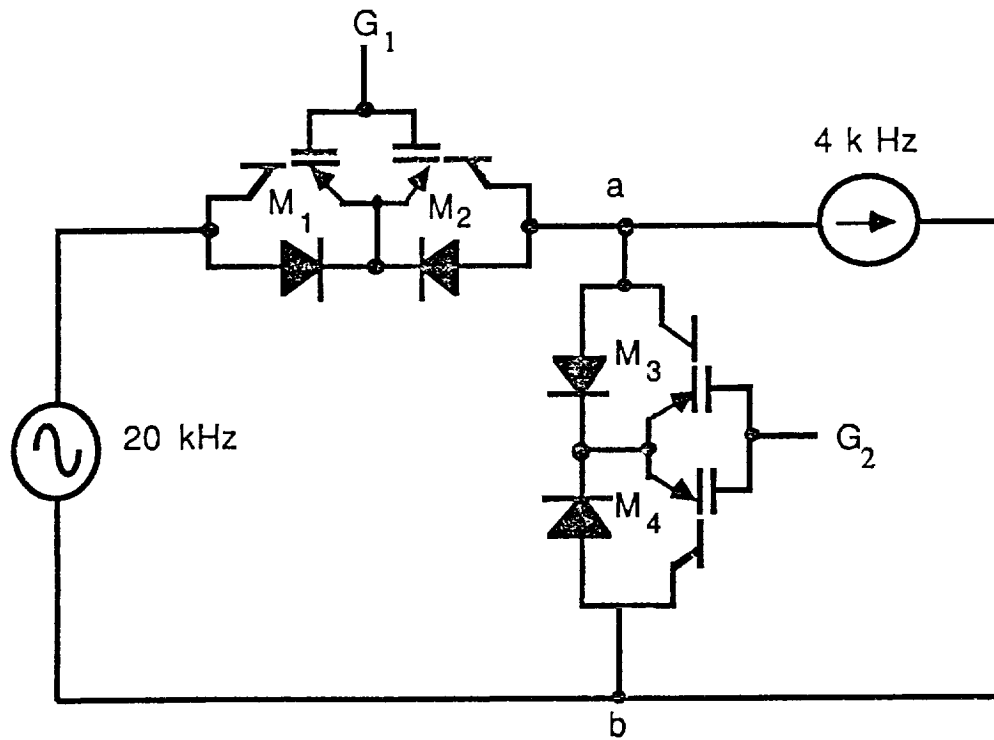

Figure 2 1-phase PDM ac resonant link converter using MCTs

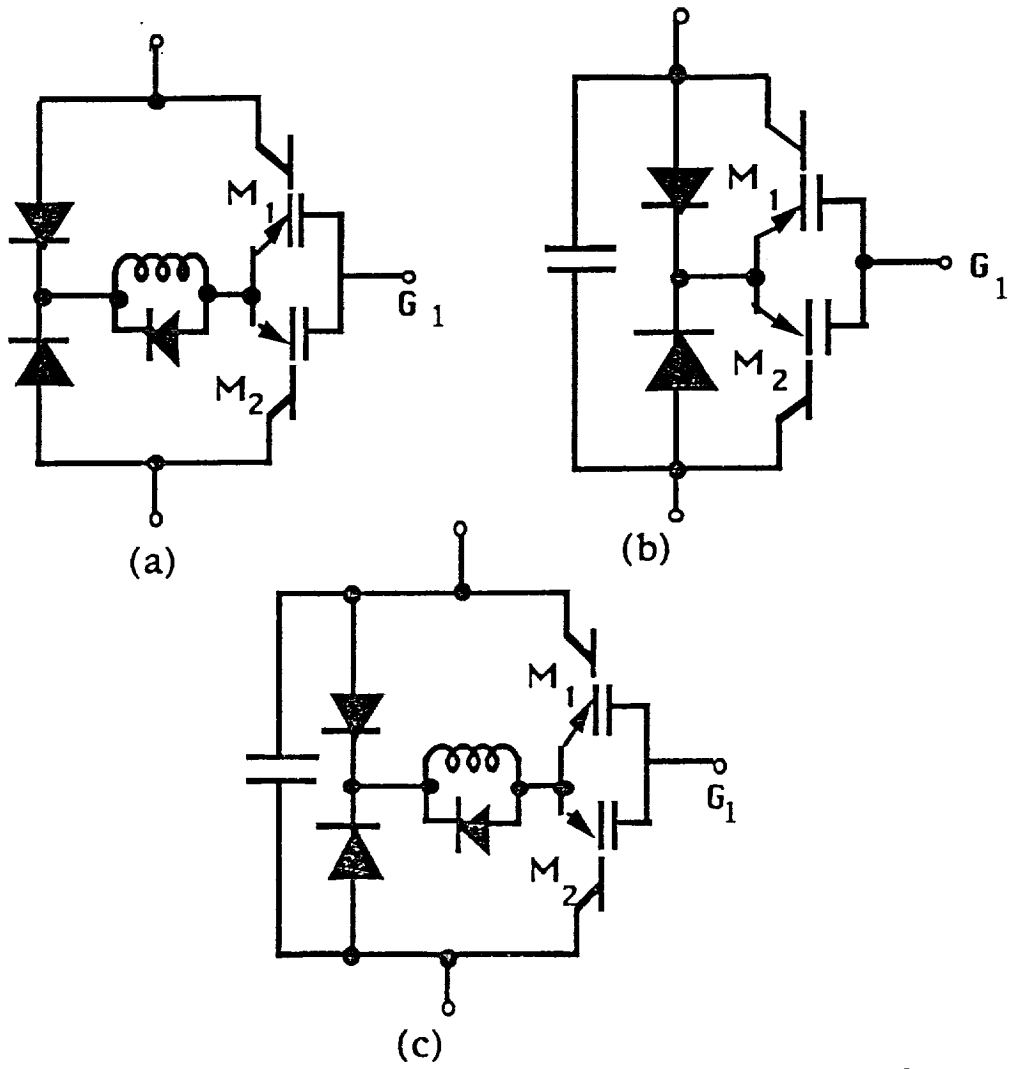

Figure 3 Different snubber circuits under investigation

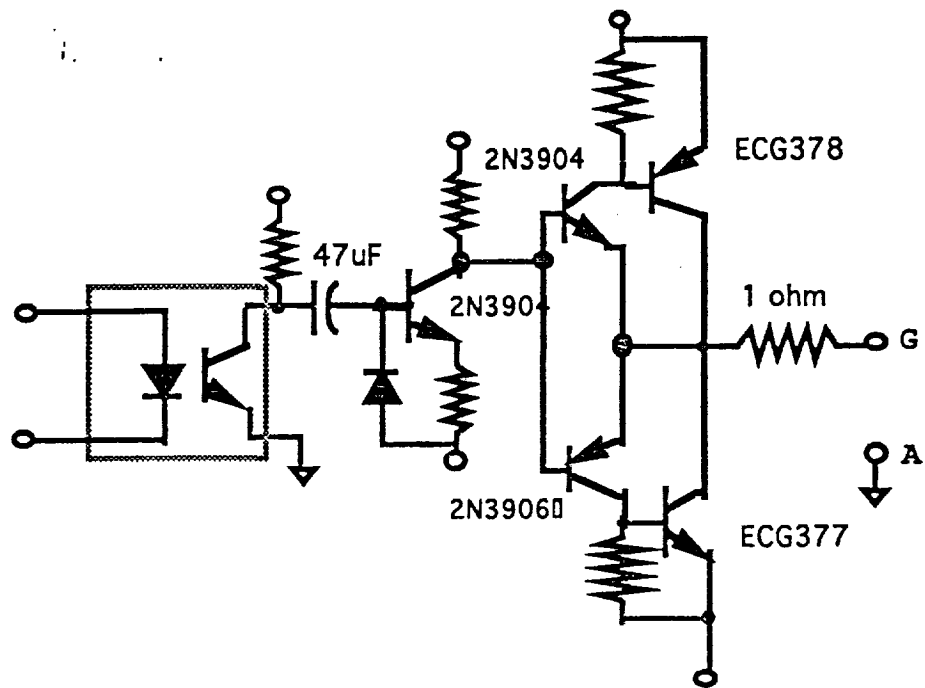

Figure 4 Improved MCT gate-drive with rise time of  $\sim 200$  nsec

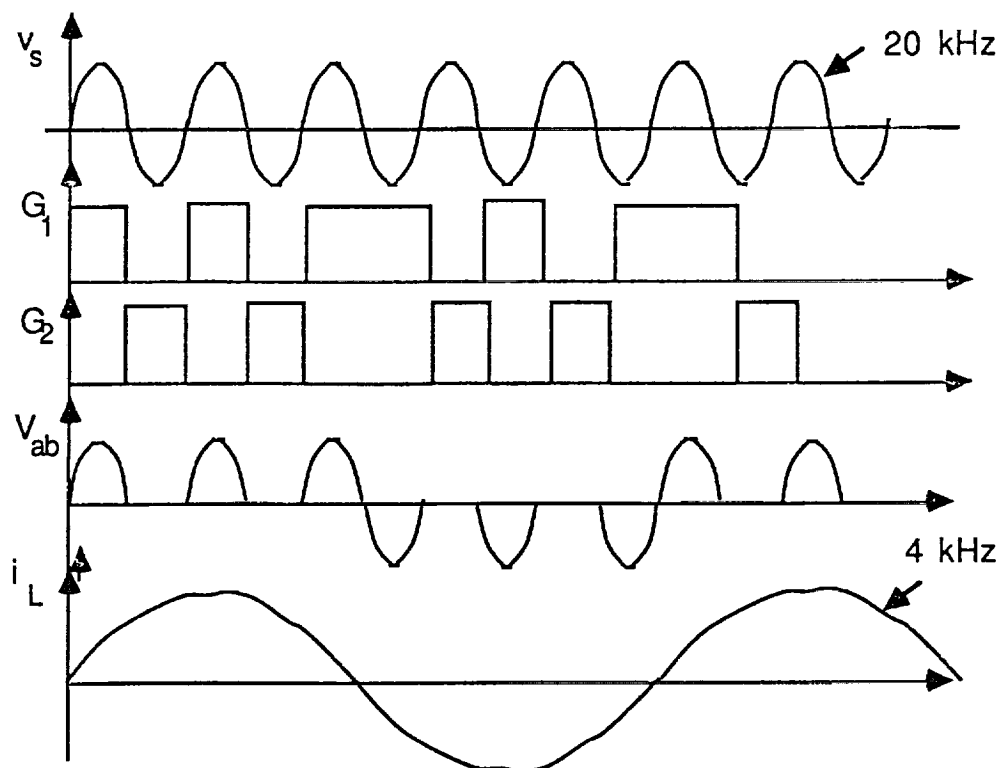

Figure 5 Timing and Control Waveforms for the Circuit of figure 2

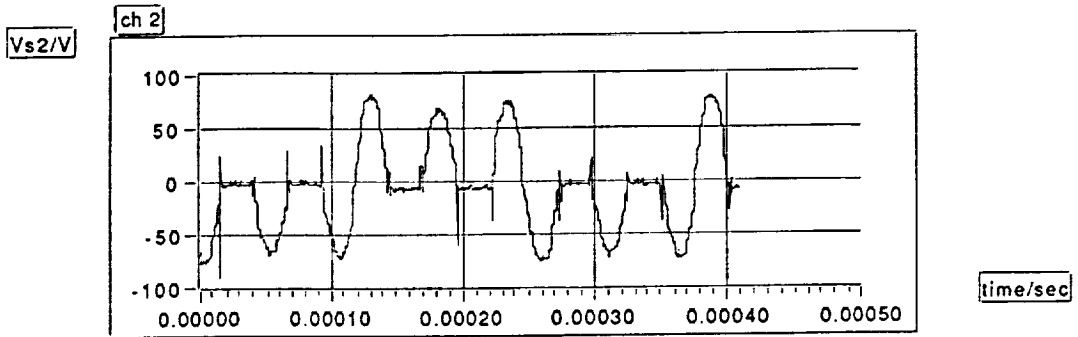
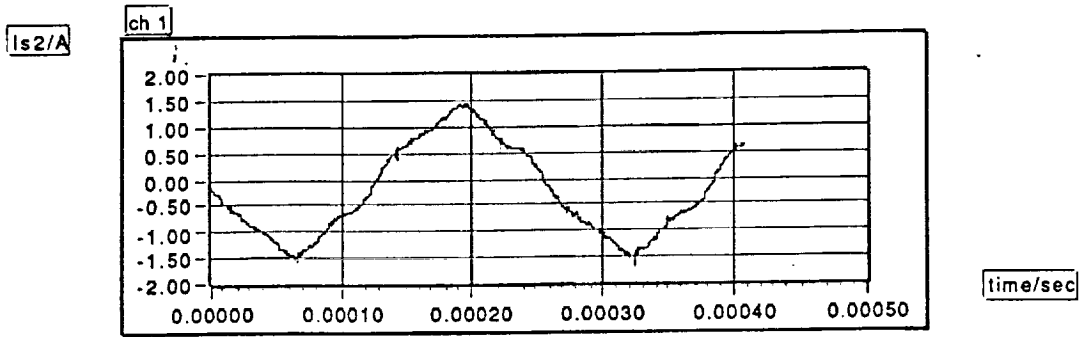

Figure 6 Experiment load current and voltage waveforms

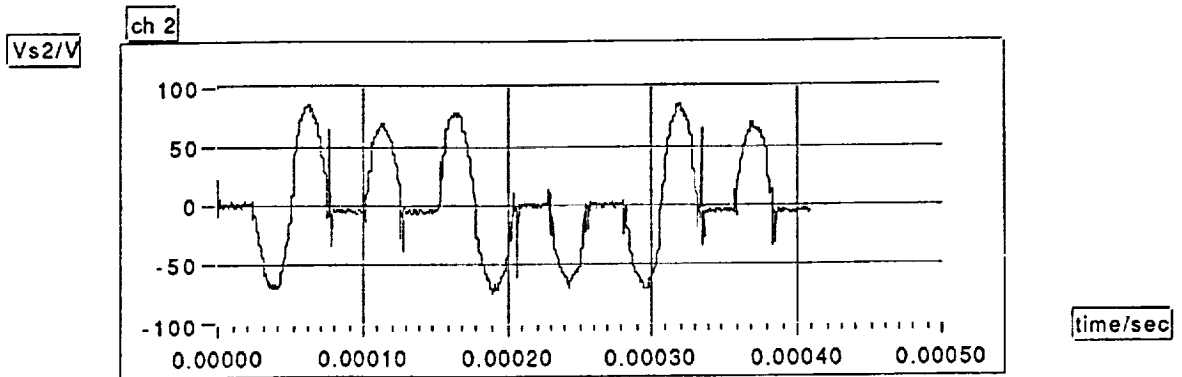
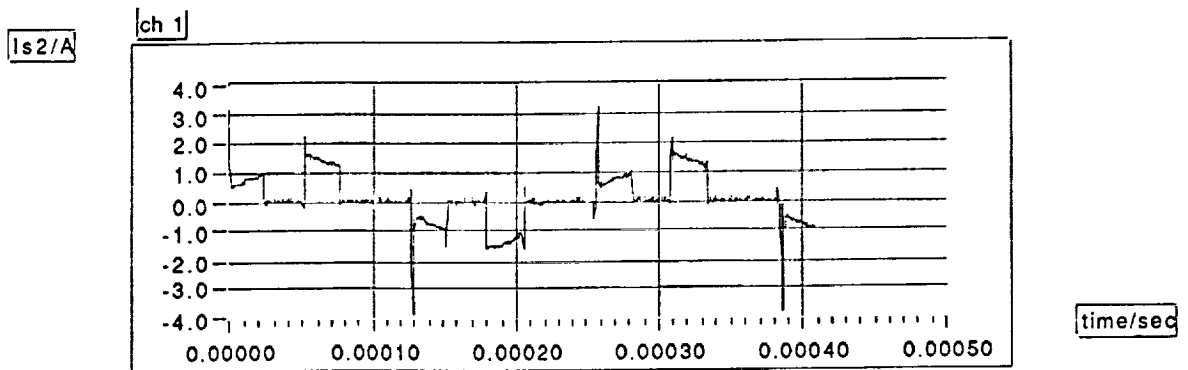
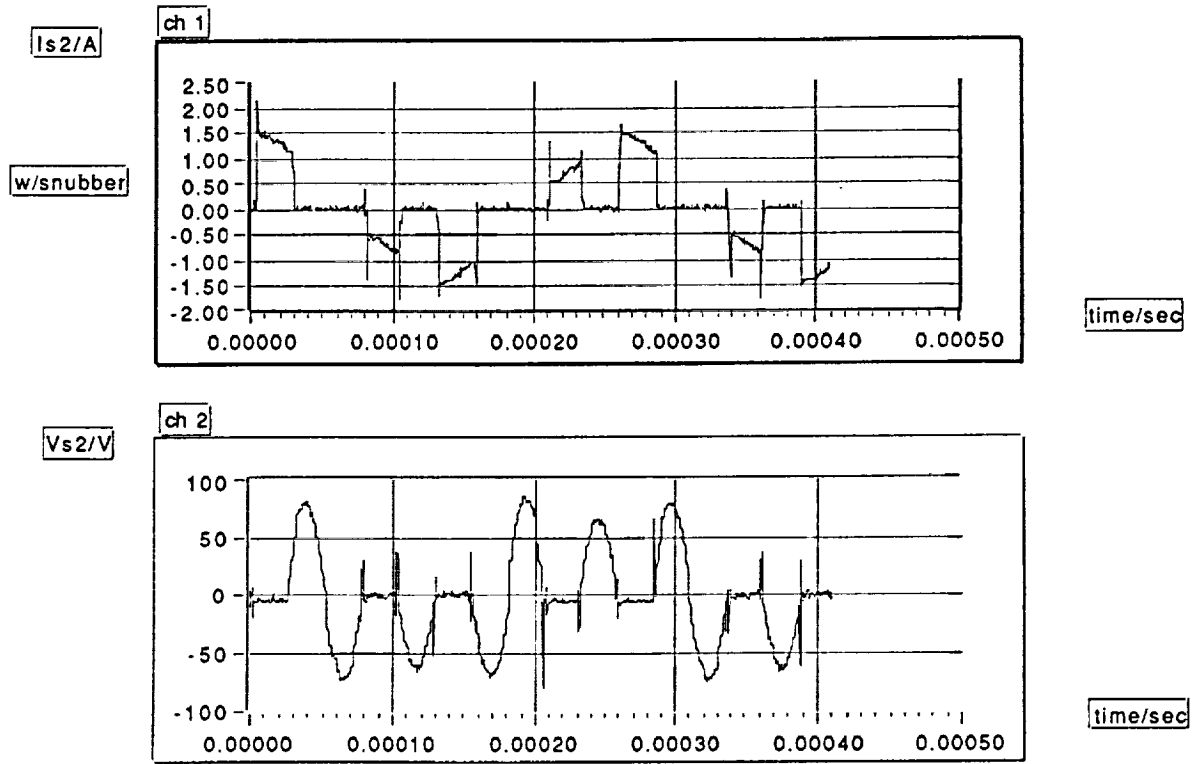

Figure 7 Current shoot-through due to turn-on advance





**Fig. 8** Current shoot-through due to turn-on advance with the snubber of figure 3(b)