

THE NASA/INDUSTRY DESIGN ANALYSIS METHODS FOR VIBRATIONS
(DAMVIBS) PROGRAM - SIKORSKY AIRCRAFT - ADVANCES TOWARD
INTERACTING WITH THE AIRFRAME DESIGN PROCESS

William J. Twomey
Sikorsky Aircraft
Stratford, Connecticut

N93-21315

ABSTRACT

A short history is traced of the work done at Sikorsky Aircraft under the NASA/industry DAMVIBS program. This includes both work directly funded by the program as well as work which was internally funded but which received its initial impetus from DAMVIBS. The development of a finite element model of the UH-60A airframe having a marked improvement in vibration-predicting ability is described. A new program, PAREDYM, developed at Sikorsky, which automatically adjusts an FEM so that its modal characteristics match test values, is described, as well as the part this program played in the improvement of the UH-60A model. Effects of the bungee suspension system on the shake test data used for model verification are described. The impetus given by the modeling improvement, as well as the recent availability of PAREDYM, has brought for the first time the introduction of low-vibration design into the design cycle at Sikorsky.

INTRODUCTION

Airframe vibration has always been a problem with helicopters. Prior to the DAMVIBS program, attempts to reduce it were usually limited to making modifications or adding vibration-control devices to an already designed and built airframe, in a trial-and-error fashion. Mathematical (finite-element) models of the airframe structure were little used as aids in this process, because they were considered to be of insufficient accuracy to reliably predict either absolute vibration levels or even relative vibration sensitivities to design changes. Analysis/test comparisons at the time did not inspire confidence.

The purpose of the DAMVIBS program was to raise the level of finite-element analysis to the point where confidence in its vibration-prediction capabilities would be possible, with the ultimate objective of encouraging its use as a means of introducing low-vibration design early into the airframe structural-design process and thus lowering the weight penalty typically paid by hardware add-ons required to bring vibration within specifications. The efforts of Sikorsky Aircraft under DAMVIBS, including the directly funded as well as the indirectly encouraged, involved both of the above aspects: (1) improving the finite-element modeling tool, and (2) finding a way to apply the tool during the airframe design process to achieve a low-vibration design with a

minimum weight penalty.

IMPROVEMENT IN FINITE-ELEMENT MODELING

It was recognized that any attempt at low-vibration design would have to rest upon a base of good predictive ability of finite-element modeling of airframes. To that end, a major effort at Sikorsky, under the DAMVIBS project, involved the re-modeling, shake testing, analysis/test comparison, and model improvement, of the UH-60A airframe (Fig. 1).

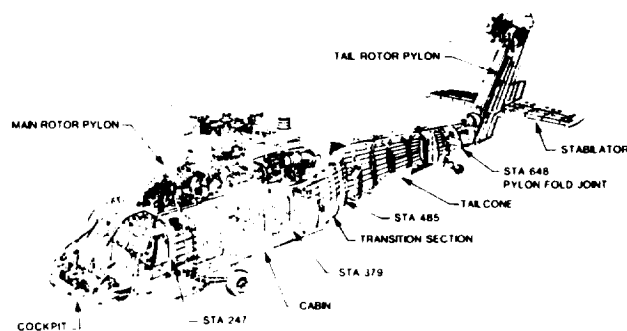

Fig. 1 UH-60A Black Hawk fuselage structure.

Re-modeling the UH-60A

Increasing the Mesh Fineness The re-modeling of the UH-60A airframe is described in detail in Ref. 1. The mesh fineness of the stiffness model was increased in many areas over the pre-DAMVIBS model. Many of the frames, beams, and longerons, which had previously been modeled as single BAR-element lines, were now modeled as double lines of BAR elements, in order to provide improved continuity at intersections of important structural components and to be better able to assess the physical parameters of the latter. This also allowed for easier input of cross-sectional properties, and a more desirable element-force output for the (static) stress analysts.

The resulting stiffness model of the DAMVIBS model has over twice the number of d.o.f. (25,000 in the g-set) as the pre-DAMVIBS model. The fineness of the mass model was increased threefold, to about 450 mass lumps.

Modeling Secondary Structure The stiffness modeling of some secondary structure, most notably the cabin floor, was included for the first

time. The complete re-modeled DAMVIBS finite element model (FEM) is shown in Fig. 2.

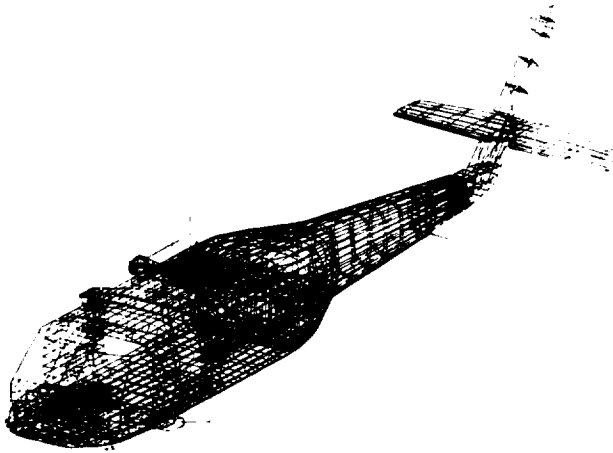

Fig. 2 UH-60A DAMVIBS finite element model.

Updating the Element Properties Prior to DAMVIBS, an FEM of a helicopter airframe would typically be created during preliminary design, and then left unchanged throughout the remaining life of the aircraft, the significant cost of updating the model not being deemed worth its uncertain rewards. Since the final airframe design would usually differ significantly from the preliminary design, it is not surprising that large discrepancies usually occurred between the FEM and the actual shake-tested airframe. An important part of the DAMVIBS re-modeling effort was the updating of all of the element properties in the FEM to match those of the final-design drawings.

Comparison of the DAMVIBS FEM with Shake Test Results

Shake Testing the UH-60A The UH-60A production airframe was rigorously shake-tested, using stepped-sine frequency-excitation sweeps with the forces applied at the main rotor hub, one direction at a time. The testing was controlled by computer software developed by Imperial College of Science and Technology. The resulting frequency response functions (FRF's) were stored on computer discs, and were subsequently curve-fitted to obtain the modal properties of the structure, using both the Imperial College and the SMS Modal 3 SE software systems. The testing and analysis of test data is described in detail in Reference 2 (for the 10,000 lb weight-empty configuration) and in Reference 3 (for the 13,500 lb minimum-flight-weight configuration).

Analysis/test Comparison Analysis/test comparisons are described in detail in References 2 and 4 (for the 10,000 lb configuration) and in Ref. 5 (for the 13,500 lb configuration). Fig. 3 shows a comparison of the natural frequencies predicted by the 13,500 lb DAMVIBS FEM compared with those extracted from the test

frequency-response functions. In general, the analytical frequencies are lower than test, with an average error of 7.5%. While this is a significant improvement over the pre-DAMVIBS model (which had an average error of 12.8%), significant differences still remained to be resolved before real confidence in the vibration-prediction ability of the model could be established.

Mode	Mode Description	Test Frequency (Hz)	NASTRAN Results			
			Pre-DAMVIBS FEM		DAMVIBS FEM	
			Freq.	% Error	Freq.	% Error
1	1st lateral bending	5.36	4.77	-11	4.96	-8
2	1st vertical bending	6.07	5.42	-11	5.83	-4
3	Stabilator roll	9.68	8.10	-16	9.13	-6
4	Stabilator yaw	10.18	9.83	-3	11.07	9
5	Transmission pitch	12.25	9.46	-23	10.63	-13
6	Transmission roll/ 2nd lateral bend	13.90	11.44	-15	12.53	-7
7	Same, opposite phase	13.94	12.71	-9	13.39	-4
8	2nd vertical bending	14.10	10.52	-25	11.63	-18
			14.63			
9	Transmission vertical	15.86	14.90	-6	14.69	-7
			14.81		15.84	
10	Cabin torsion 2nd lateral bend	17.41	15.77	-9	17.27	-1
11	Same, opposite phase	21.57	17.23		18.24	
			19.84		18.22	
			20.23		20.94	
			22.44		21.22	
					21.39	

Fig. 3 Comparison of pre-DAMVIBS and DAMVIBS FEM'S with shake test.

Improvement to the UH-60A DAMVIBS FEM

Development of PAREDYM One of the most important results of the DAMVIBS project was the change in climate in industry regarding the importance of airframe finite element modeling. This change manifested itself at Sikorsky in the decision taken about six years ago to embark, with aid of the University of Bridgeport, upon a project to develop a method which would automatically modify the element properties in an FEM so that its modal characteristics would agree with those found in test; in other words, a method which would scientifically identify the causes of the discrepancies between predicted and measured values.

Based on the method described in Ref. 6, a general method, called PAREDYM (PARAmetric REfinement of DYnamic Models), was developed and programmed in MSC/NASTRAN DMAP language (Ref. 5). In this program, FORTRAN codes are used for iterative looping control and for updating, in each loop, the NASTRAN input bulk data.

The iteration procedure of the method is as follows:

- (1) Start with an initial FEM. Set iteration counter $k=0$.
- (2) Perform modal analysis (Rigid Format 63) to determine $\{Y_a\}_k$, where $\{Y_a\}$ includes natural frequencies $\{\omega_a\}$ and mode shapes $\{\phi_a\}$.

- (3) Compute design sensitivity matrix $[T]_k$ (Rigid Format 53) and the modal differences $(\Delta Y)_k = \{Y_e\} - \{Y_a\}_k$, where $\{Y_e\}$ = modal values from test.
- (4) Set $(\Delta B)_{k+1} = ([T]^T [T])^{-1} [T]^T (\Delta Y)_k$
- (5) Update FEM
- (6) Check the convergence criterion for analysis/test agreement in modal values.
 - a. Stop procedure if it is met.
 - b. Continue procedure if it is not met.
- (7) Set $k = k+1$ and go to step (2).

This process continues until the desired agreement with test is obtained. Difficulties encountered, such as matrix ill-conditioning and mode crossing, when applying the method to real large-scale structures, are discussed in Ref. 5. Ref. 7 describes an efficient way, developed and applied in PARELYM, of accommodating ill-conditioned equations, called epsilon-decomposition.

Applying PARELYM to the UH-60A FEM
 PARELYM was applied to the UH-60A, using the FEM of Fig. 2, generated under DAMVIBS, together with the test data obtained under DAMVIBS. To keep the computer time manageable, use was made of the linking feature in NASTRAN which allows properties of more than one element to be tied to a single "design variable". The element properties were grouped into seven regions (Fig. 4), with the cabin section further subdivided into four regions (top, bottom, and two sides). In each region the element properties were linked together into four design variables, one linking all plate (QUAD4) elements in the outer shell and one linking them in the inner structure, with plate thickness as the design-variable parameter; one linking all beam (BAR) elements in the outer shell, and one linking them in the inner structure, with beam cross-sectional area as the design-variable parameter. These, together with five stabilator attachment spring parameters, gave a total of 45 design variables. Mass properties were kept constant.

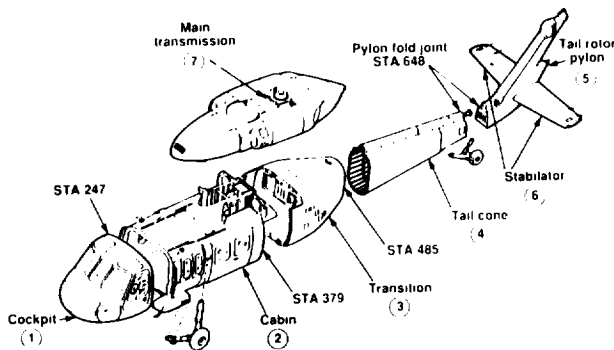

Fig. 4 UH-60A: regions within which element properties are linked for PARELYM program.

Figure 5 shows the iteration results of targeting six of the FEM's natural frequencies to their corresponding test values (The six modes chosen had the best mode-shape agreement with their test counterparts.). The frequency errors are all seen to converge to near zero in six iterations. Figure 6 shows the corresponding changes in design-variable properties which achieved this convergence.

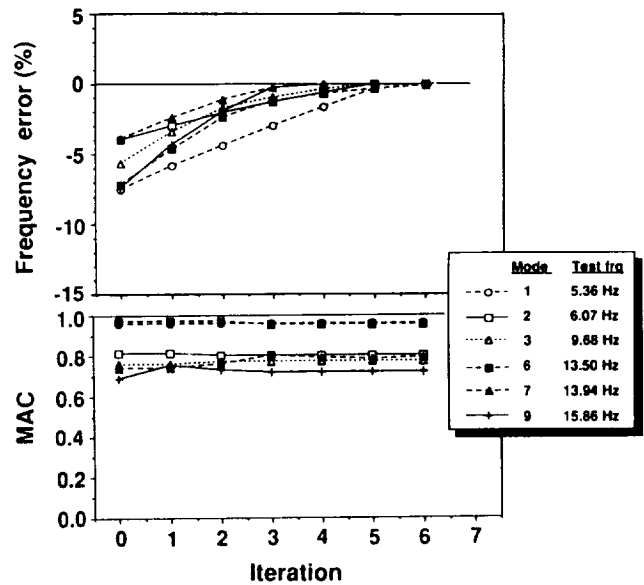

Fig. 5 UH-60A: six-mode correlation results.

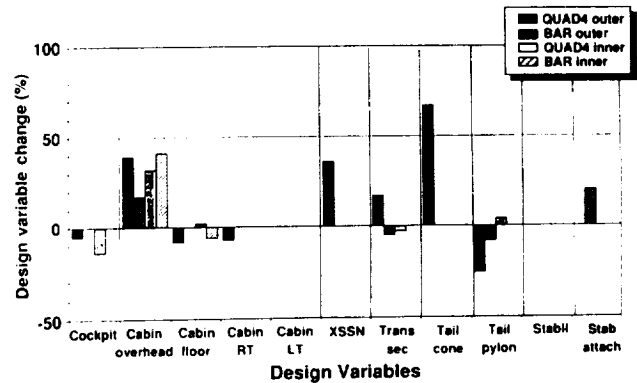

Fig. 6 UH-60A: design variable changes for six-mode correlation.

Improving the UH-60A FEM
 At this point the above-calculated element properties could have been incorporated into the FEM, with the knowledge that a good correlation of at least six of its natural frequencies was assured. However, a "mathematical fit" improvement to the model was not what was desired here, but rather a "correct" improvement, that is one based on physical modeling principles, which would result in a model capable of making trustworthy dynamic response predictions due to later structural or mass configuration modifications.

Thus the calculated updates to the element properties were examined as to what they might

be indicating regarding modeling deficiencies. The large stiffness increases called for in the cabin overhead region, for example, could be pointing to the considerable amount of unmodeled (from a stiffness standpoint) secondary structure in this region. A model of a major part of this secondary structure, the firewalls and their connecting structure, was created and added to the airframe FEM. It was surmised that the stiffness increase called for in the main transmission was due to the neglecting of the stiffeners in the connecting structure between the input modules and the main housing. To account for this, the thickness of the plate elements in this region were doubled. The large stiffness increases called for in the tail cone region were not acted upon since no physical justification for them could be thought of.

With the above modeling changes, plus the addition of a rough model of the windshield and cockpit doors, the agreement of the model with test has improved to the point where serious confidence in its predictions is now possible. As shown in Figure 7, there now exists a one-to-one correspondence between the first 10 analytical modes and the first 10 fuselage test modes, in the frequency range up through the blade passage frequency of 17.2 Hz (Two test modes which had their origin in the suspension system are not included here but will be discussed in the next section.). The average frequency error of these modes has now dropped from 7.5% to 3.2%, and the average MAC value has increased from 0.70 to 0.82 (the MAC value is an indicator of mode shape agreement, 1.0 indicating perfect agreement). Figures 8 and 9 show the improvement of a representative frequency response function (FRF) resulting from these latest modeling changes. Further details of the above are given in Ref. 6.

Mode	Mode Description	Test Frequency (Hz)	NASTRAN Results			
			DAMVIBS FEM		Impr. DAMVIBS FEM	
			Freq.	% Error MAC	Freq.	% Error MAC
1	1st lateral bending	5.36	4.96	-8.0%	4.99	-7.0%
2	1st vertical bending	6.07	5.83	-4.0%	6.02	-1.0%
3	Stabilator roll	9.68	9.13	-6.0%	9.16	-5.0%
4	Stabilator yaw	10.18	11.07	9.0%	11.04	8.0%
5	Transmission pitch	12.25	10.63	-13.0%	11.57	-6.5%
6	Transmission roll 2nd lateral bend	13.50	12.53	-7.0%	13.05	-3.0%
7	Same opposite phase	13.94	13.39	-4.0%	14.06	1.0%
8	2nd vertical bending	14.10	11.63	-16.5%	13.33	-5.0%
9	Transmission vertical	15.86	14.69	-7.0%	16.06	1.0%
10	Cabin roll 2nd lateral bend	17.41	14.81			
			15.84			
11	Same opposite phase	21.57	18.24		20.43	
			18.32		20.89	
			20.94		21.15	
			21.22		22.00	
			21.39			

Fig. 7 Comparison of DAMVIBS and improved DAMVIBS FEM's with shake test.

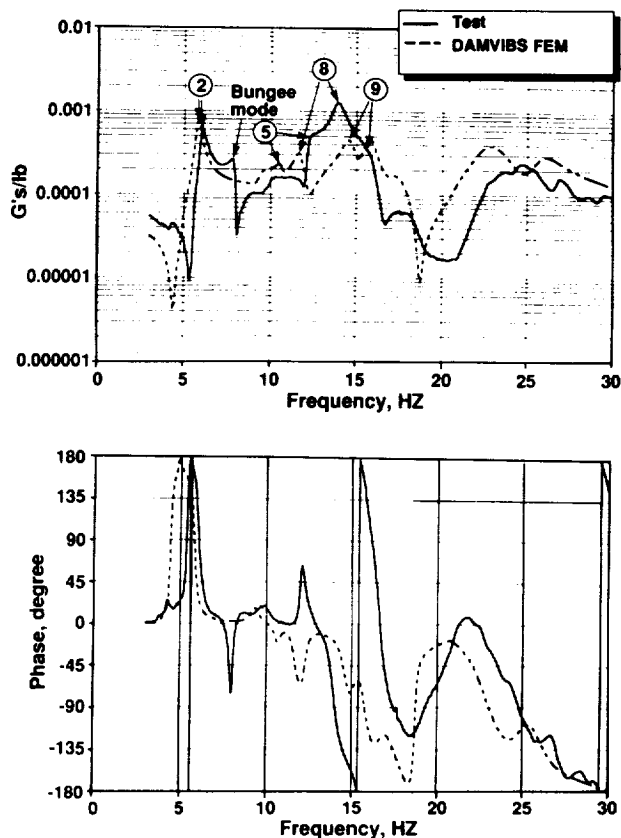

Fig. 8 Comparison of DAMVIBS FEM with test (pilot vert. response to long. excitation at main rotor head).

Effect of Bungee Suspension System

Along with the closer look given to finite element modeling, a closer look was also given to the shake test data which were being used for model verification. As an example of this closer look, the test FRF in Fig. 9 shows evidence of a test mode near 7.9 Hz for which no analytical equivalent is calculated. This test mode, and another one of similar frequency, in response to a lateral shake, were suspected of being modes originating not with the fuselage, but with transverse motions of the suspension system. A large response peak near 7.9 Hz, for an accelerometer placed on the suspension system during one frequency sweep, provided additional evidence for this.

The airframe was suspended from the ceiling, during shake testing, by a bungee system shown schematically in Figure 10. Since the bungees are made soft enough to keep the rigid body modes of the airframe low with respect to its elastic

modes, airframe analyses have traditionally been run in a free-free condition with the suspension system unmodeled. To investigate the effect of the suspension system on the test results, and thus on the analysis/test correlation, an FEM of the suspension system was formulated and added to the improved fuselage FEM. Modal analyses were done using the differential stiffness approach in NASTRAN in order to include the necessary stiffening effects of gravity on the suspension system.

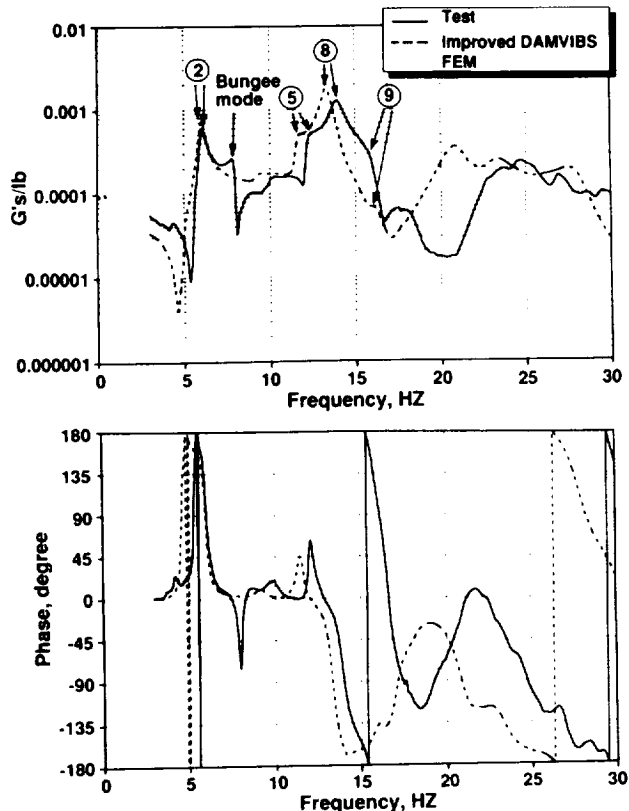

Fig. 9 Comparison of improved DAMVIBS FEM with test (pilot vert. response to long. excitation at main rotor head).

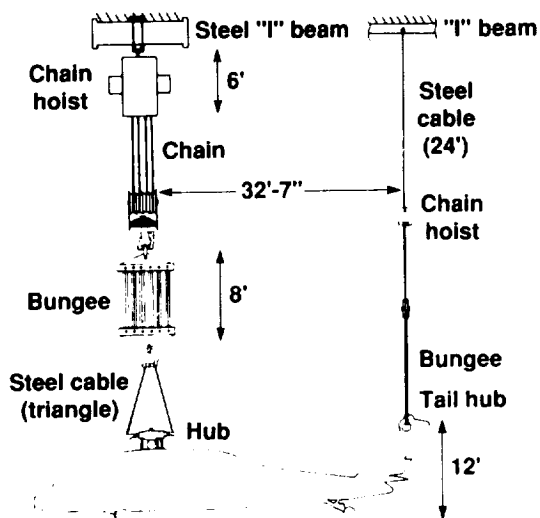

Fig. 10 Schematic of airframe suspension system in shake test.

Figure 11 shows a comparison with test of the same FRF after the addition of the model of the suspension system. It is seen that the analysis with the suspension system predicts an additional mode (at 7.37 Hz) which is close in frequency to the previously-unmatched test mode (found at 7.9 Hz). The analytical mode is basically a fore-and-aft mode of the main rotor suspension system, but, as seen in the analytical shape (Figure 12), it couples strongly with the fuselage, causing the mode to appear in test as a fuselage mode. The striking agreement between the analytical and the test mode shapes, in the fuselage region, the only region measured, adds evidence that this test mode is now being correctly predicted.

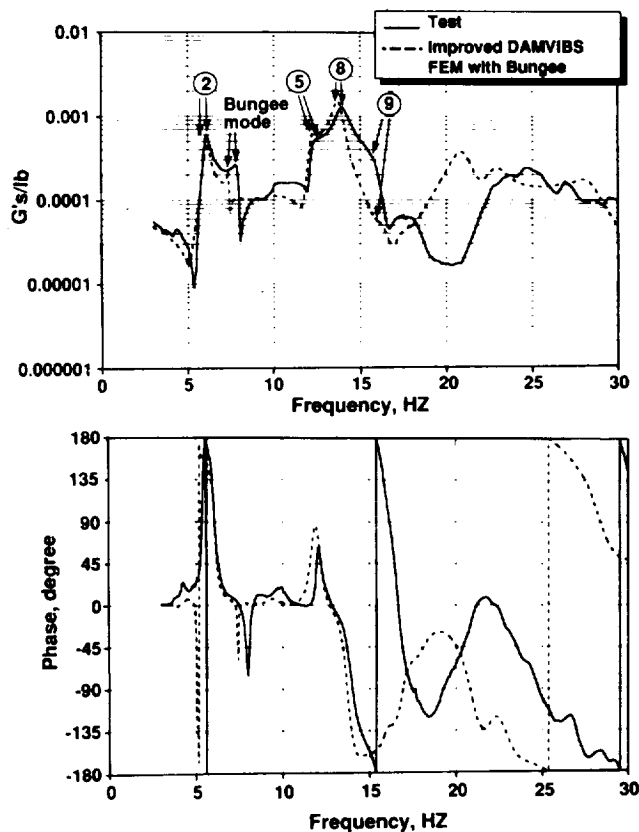

Fig. 11 Comparison of improved DAMVIBS FEM with suspension system with test (pilot vert. response to long. excitation at main rotor head).

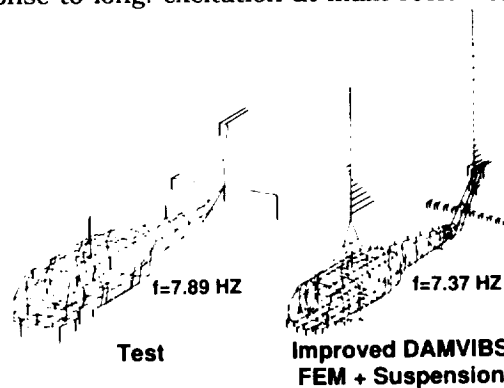

Fig. 12 Comparison of improved DAMVIBS FEM with suspension system with test (suspension-system mode shape).

DESIGNING LOW VIBRATION INTO A NEW AIRFRAME

With newly-found confidence in the ability of a FEM to predict the vibration properties of a structure, the next logical step was to move into the final area addressed by DAMVIBS, namely the introduction of low-vibration design into the airframe design process. Although the PAREDYM program was originally developed to improve a finite element model (FEM) to bring it into agreement with test, the generality of its formulation allows for its use also as a minimum-vibration design tool. In essence, the program calculates a minimum set of element property changes which cause the modal properties (natural frequencies and mode shapes) of the FEM to move in the direction of a pre-assigned set of target values. These target values can be obtained from shake test (when it is desired to bring the FEM into agreement with existing test data), or they can be a set of design goals (in the case of a structure under design) which are desired for the structure, in order for it to have low response levels, at the required critical locations, and under the expected excitation forces and frequencies.

Application to a New Design

Natural Frequency Modification With the next new helicopter design at Sikorsky, low-vibration design was attempted from the earliest preliminary-design stages. A frequency-response analysis was made of an early-design 3000-d.o.f. FEM of this aircraft, using blade-passage-frequency hub loads derived from rotor wind tunnel tests as the inflight excitation forces. Initial results are shown in Figure 13, for pilot lateral and vertical response, with the hub load frequency artificially varied over a range of frequencies, in order to better understand the nature of the response. At the blade passage frequency, the calculated responses were found to be excessive. To reduce them, six modes, all having natural frequencies near the excitation frequency, were identified as being the major contributors to the vibratory response. PAREDYM was used to move these modes away from the excitation frequency, and in Fig. 14 it can be seen that by the seventh iteration they all have moved well out of that neighborhood. The new frequency response plots reflect this shift in natural frequencies in the absence of nearby resonance peaks (Fig. 15). Pilot lateral response has accordingly been reduced by 62%. However, contrary to expectations, the pilot vertical response has actually increased.

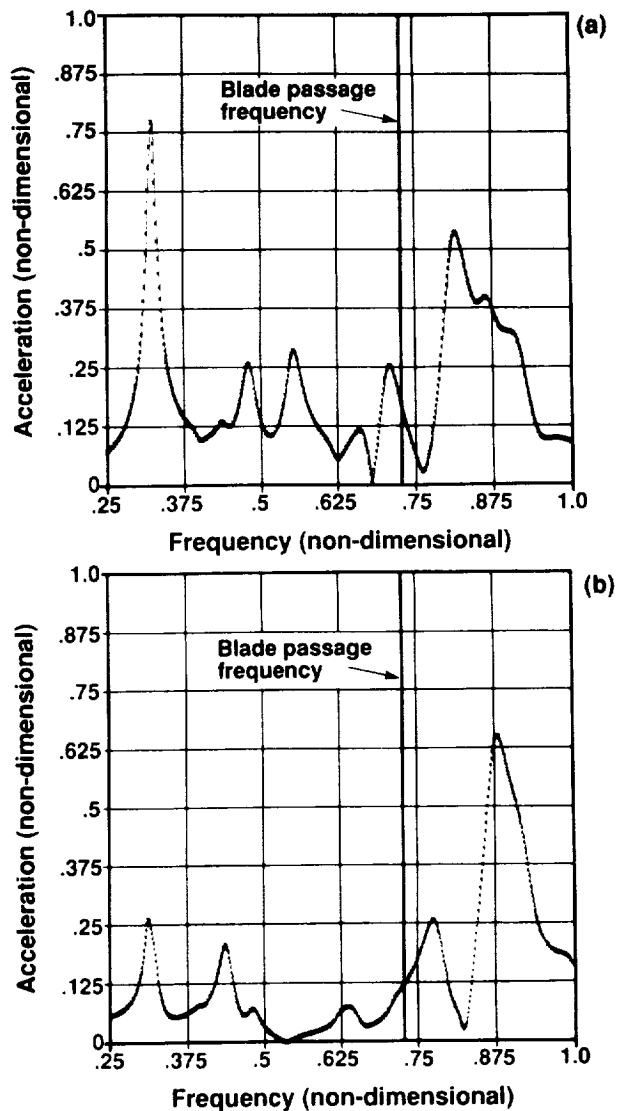

Fig. 13 Initial design: pilot (a) lateral and (b) vertical responses vs excitation frequency.

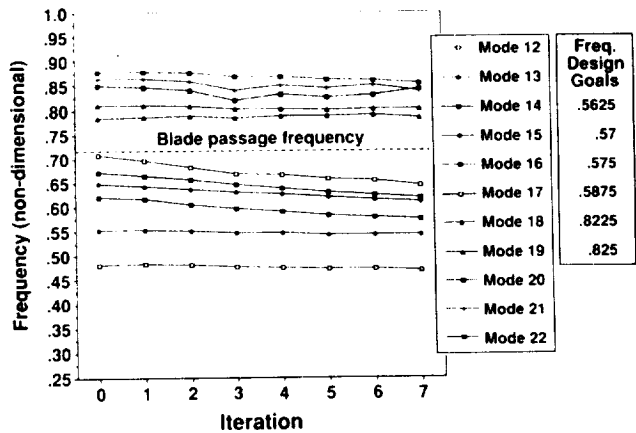

Fig. 14 Frequency optimization: natural frequencies vs solution iteration (no constraints).

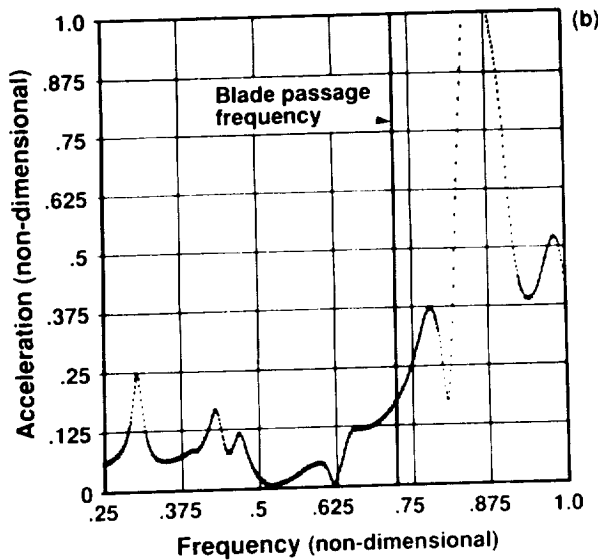
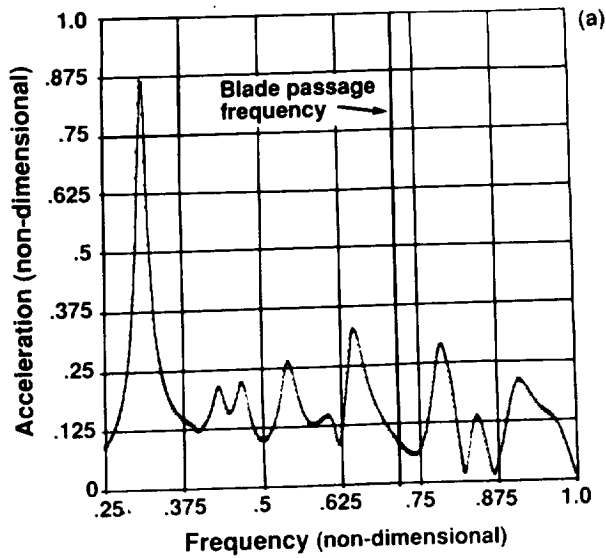

Fig. 15 Frequency optimization: pilot (a) lateral and (b) vertical responses vs excitation frequency (no constraints).

Mode Shape Modification In an effort to further reduce the responses, the critical-location components of the mode shapes contributing the most to the responses, were targeted to be reduced in PARESYM. Figure 16 shows the reduction of the mode shape components at pilot

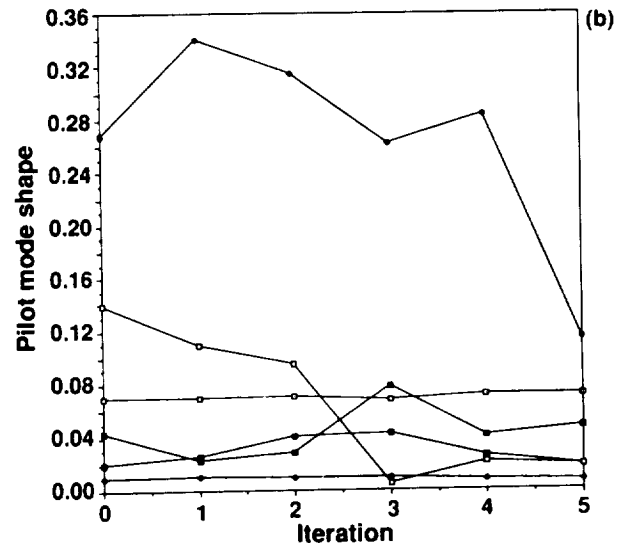
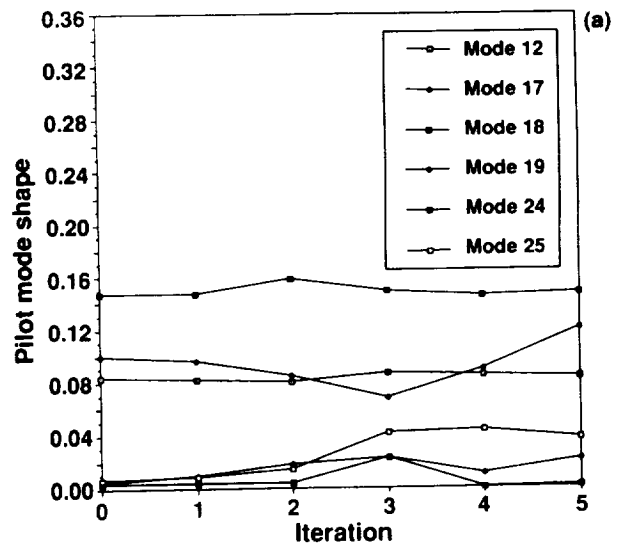

Fig. 16 Mode shape optimization: mode shape vs solution iteration, pilot (a) lateral and (b) vertical components (no constraints).

vertical after five iterations. The two largest components at pilot vertical are seen to drop by 60% and 85%. Figure 17 shows the frequency responses at the same location following the last iteration; a 67% overall reduction in pilot response has been achieved.

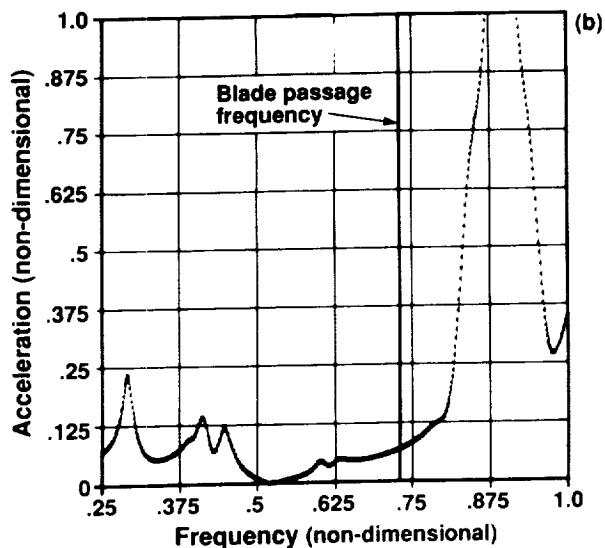
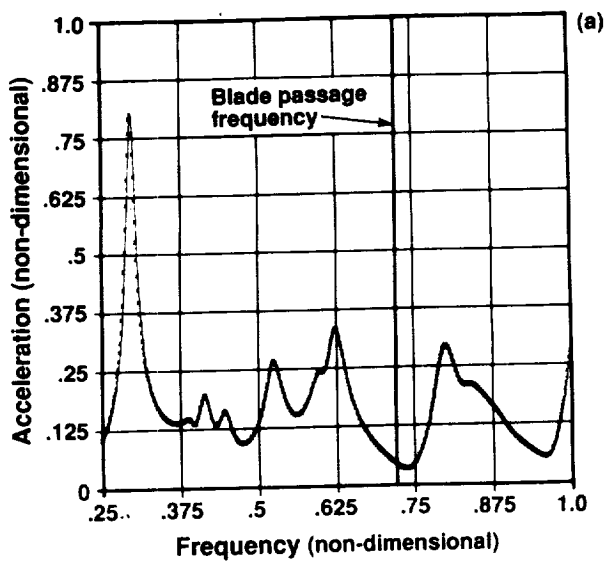

Fig. 17 Mode shape optimization: pilot (a) lateral and (b) vertical responses (no constraints).

Figure 18 shows the associated design variable changes in the cabin (beam cross-sectional areas and skin panel thicknesses), that accompanied the above vibration reduction. The changes are seen to range from a 500% increase to a 80% decrease. The extremes of these changes were not considered to be feasible, from a design standpoint. The large stiffness increases would cause a considerable weight penalty, in the present case amounting to 2% of the total weight of the helicopter. The large stiffness reductions could severely reduce the life of the structure. It was thus considered necessary to introduce into the program both the ability to minimize the total weight change, as well as the ability to put limits on the individual design variable changes.

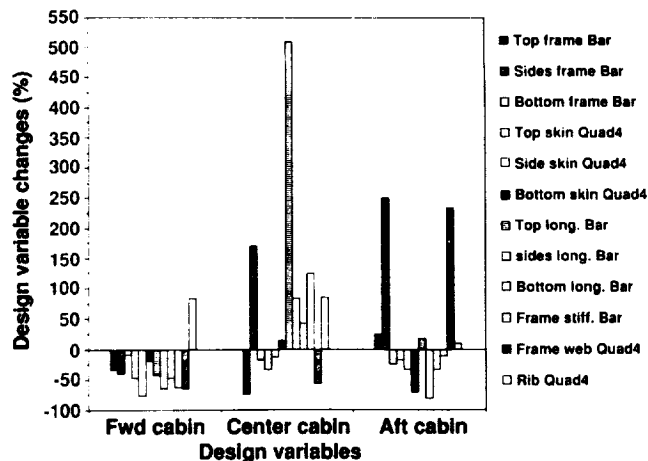

Fig. 18 Frequency and mode shape optimization: cabin design-variable changes (no constraints).

Incorporation of Total-weight-change Minimization and Design-variable Side Constraints into PARELYM To minimize the total weight increase of the structure, the sum of all the mass changes implied by the design variable stiffness changes was introduced explicitly into the objective function, for minimization, through the use of Lagrange multipliers.

For the design problem, the size of many members can only be reduced by a limited amount to ensure the structural strength and can only be increased a certain amount to maintain proper weight distribution. In order to achieve these requirements, upper and lower bounds (side constraints) on the design variable changes are imposed in each iteration. Should the design variables become higher or lower than the respective preset limits, they are set equal to those limits.

Effect of Including Minimum Weight Change and Design Variable Constraints Following the incorporation of the above two capabilities, the low-vibration design problem was re-examined. A total-mass-change minimization was introduced, as well as $\pm 30\%$ side constraints on each design variable. Figure 19 shows the resulting new frequency-modification results with the above constraints now included. Comparing with Figure 14, it is seen that the natural frequencies now have more difficulty in converging to their target frequencies. This is expected; when the most sensitive (effective) design variables reach their limits, the program has to switch to less effective design variables to continue the frequency shifting, thus slowing down the process.

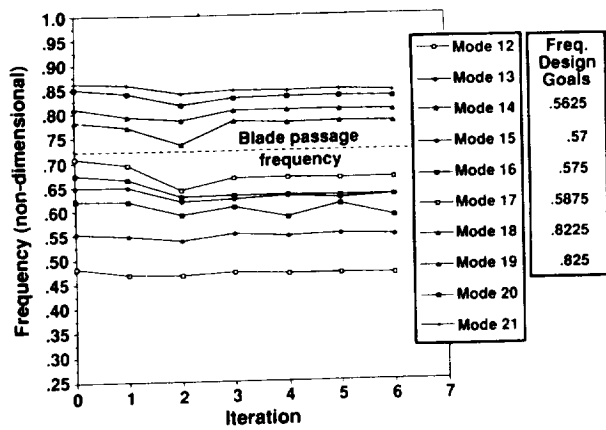

Fig. 19 Frequency optimization: natural frequencies vs solution iteration (constraints applied).

Figure 20 shows the corresponding FRF's at the pilot lateral and vertical, following these iterations, with the above constraints applied. The resulting changes in pilot response, compared to the original design, are a 54% reduction in pilot lateral, and a 1% increase in pilot vertical, giving an overall reduction of 39% in the resultant pilot response (pilot lateral was originally twice as large as pilot vertical), with the total weight increase equaling only 0.1% this time. Although this is less than the 67% overall vibration reduction achieved earlier without constraints, it now represents a more realistic goal. Further details on the methods used for low-vibration design are given in References 8 and 9.

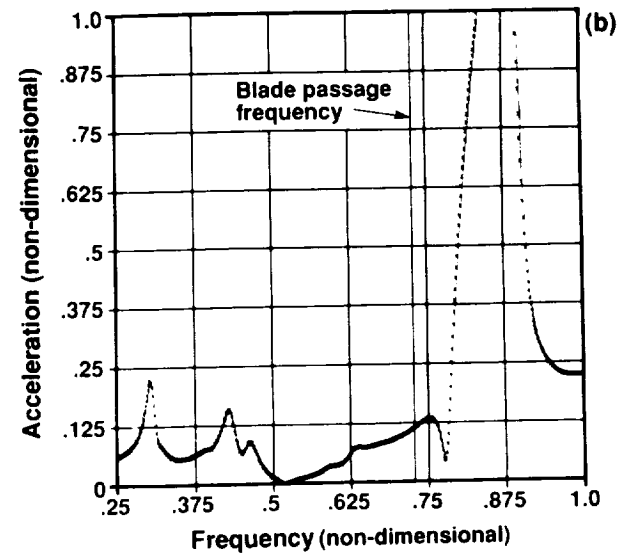
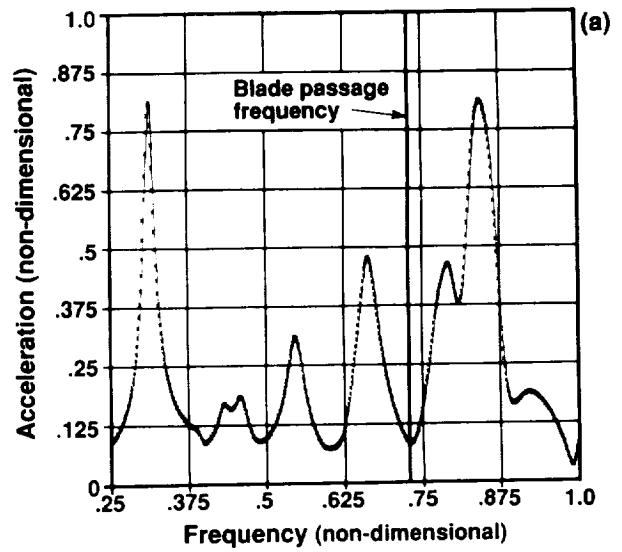

Fig. 20 Frequency optimization: pilot (a) lateral and (b) vertical responses (constraints applied).

CONCLUSIONS

A short history has been traced of the work done at Sikorsky Aircraft under the NASA/industry DAMVIBS program. This includes both work directly funded by the program as well as work which was internally funded but which received its initial impetus from DAMVIBS.

The development of a finite element model of the UH-60A airframe having a marked improvement in vibration-predicting ability has been traced. A new program, PAREDYM, which automatically adjusts an FEM so that its modal characteristics match test values, has been developed at Sikorsky. This program has shared in the improvement of the UH-60A model.

Along with the closer look at finite element modeling, which was engendered by the DAMVIBS program, came also a closer look at the shake test data which were being used for model verification. A preliminary investigation showed important effects on the airframe test data of the bungee system used to suspend the test article, effects not normally accounted for in finite element modeling.

The impetus given by the modeling improvement as well as the new availability of PAREDYM brought the introduction of low-vibration design, through the control of modal parameters, into the airframe structural design cycle at Sikorsky. A description of how PAREDYM was used to do this, along with some of the difficulties encountered, was described.

The objective of the DAMVIBS program was to raise the level of the finite-element modeling of helicopter airframes to the point where it would be taken seriously in its ability to predict vibration and in its ability to bring low vibration into the airframe design process. DAMVIBS has succeeded in doing this. Although much improvement remains to be done, it has brought respectability to the analytical prediction of inflight helicopter vibration, and its stated goal of bringing low vibration into the design process of helicopter airframes has been seriously begun.

REFERENCES

1. Dinyovszky, P. and Twomey, W. J., Plan, Formulate, and Discuss a NASTRAN Finite Element Model of the UH-60A Helicopter Airframe, NASA Contractor Report 181975, February 1990.
2. Howland, G. R., Durno, J. A., and Twomey, W. J., Ground Shake Test of the UH-60A Helicopter Airframe and Comparison with NASTRAN Finite Element Model Predictions, NASA Contractor Report 181993, March 1990.
3. Durno, J. and Goodman, R., "Examination of Dynamic Characteristics of UH-60A and EH-60A Airframe Structures," Proceedings of the 45th Annual Forum of the American Helicopter Society, Boston, MA, May, 1989.
4. Durno, J. A., Howland, G. R., and Twomey, W., "Comparison of Black Hawk Shake Test Results with NASTRAN Finite Element Analysis," Proc. of the 43rd Annual Forum and Technology Display of the American Helicopter Society, St. Louis, MO, May, 1987.
5. Twomey, W. J., Chen, T. L. C., Ojalvo, I. U., and Ting, T., "A General Method for Modifying a Finite-Element Model to Correlate with Modal Test Data," AHS Journal, Vol. 36, No. 3, July 1991.
6. Collins, J. D., Hart, G. C., Hasselman, T. K., and Kennedy, B., "Statistical Identification of Structures", AIAA Journal, 12, (2), Feb. 1974.
7. Ojalvo, I. U., "Improved Solution for Ill-conditioned Algebraic Equations by Epsilon-decomposition," AIAA Journal, Vol. 29, No. 12, Dec., 1991.
8. Chen, T. L. C., Pizzolato, S., Twomey, W. J., "Application of Nonlinear Programming Techniques to Dynamic Correlation and Design of Helicopter Structures," Proceedings of the 46th Annual Forum and Technology Display of the American Helicopter Society, May 1990.
9. Niebanck, C. F., "Progress in the Application of a Non-linear Programming Methodology to the Design of a Low-vibration Airframe", Proceedings of the AHS National Technical Specialist's Meeting "Rotorcraft Structures Technology for the 1990's and Beyond", Williamsburg, Virginia, October 28-31, 1991.

REPORT DOCUMENTATION PAGEForm Approved
OMB No. 0704-0188

Public reporting burden for this collection of information is estimated to average 1 hour per response, including the time for reviewing instructions, searching existing data sources, gathering and maintaining the data needed, and completing and reviewing the collection of information. Send comments regarding this burden estimate or any other aspect of this collection of information, including suggestions for reducing this burden, to Washington Headquarters Services, Directorate for Information Operations and Reports, 1215 Jefferson Davis Highway, Suite 1204, Arlington, VA 22202-4302, and to the Office of Management and Budget, Paperwork Reduction Project (0704-0188), Washington, DC 20503.

1. AGENCY USE ONLY (Leave blank)		2. REPORT DATE January 1993	3. REPORT TYPE AND DATES COVERED Conference Publication	
4. TITLE AND SUBTITLE A Government/Industry Summary of the Design Analysis Methods for Vibrations (DAMVIBS) Program			5. FUNDING NUMBERS WU 505-63-36-01	
6. AUTHOR(S) Raymond G. Kvaternik (Compiler)				
7. PERFORMING ORGANIZATION NAME(S) AND ADDRESS(ES) NASA Langley Research Center Hampton, VA 23681-0001			8. PERFORMING ORGANIZATION REPORT NUMBER	
9. SPONSORING/MONITORING AGENCY NAME(S) AND ADDRESS(ES) National Aeronautics and Space Administration Washington, DC 20546-0001			10. SPONSORING/MONITORING AGENCY REPORT NUMBER NASA CP-10114	
11. SUPPLEMENTARY NOTES A compilation of papers presented in the special session "Finite Element Analysis of Rotorcraft Vibrations" at the 33rd Structures, Structural Dynamics and Materials Conference, April 13-15, 1992, Dallas, Texas				
12a. DISTRIBUTION/AVAILABILITY STATEMENT Unclassified-Unlimited Subject Category 39			12b. DISTRIBUTION CODE	
13. ABSTRACT (Maximum 200 words) The NASA Langley Research Center in 1984 initiated a rotorcraft structural dynamics program, designated DAMVIBS (Design Analysis Methods for VIBrationS), with the objective of establishing the technology base needed by the rotorcraft industry for developing an advanced finite-element-based dynamics design analysis capability for vibrations. An assessment of the program showed that the DAMVIBS Program has resulted in notable technical achievements and major changes in industrial design practice, all of which have significantly advanced the industry's capability to use and rely on finite-element-based dynamics analyses during the design process. A special session on finite element analysis of rotorcraft vibrations was held at the AIAA 33rd Structures, Structural Dynamics and Materials Conference, April 13-15, 1992, in Dallas, Texas to collectively summarize the accomplishments and contributions of the industry participants in the DAMVIBS Program. The special session included 5 papers. The first paper was an overview of the program from the perspective of the NASA manager of the program. The subsequent papers presented more detailed technical summaries of the specific accomplishments of the four industry participants as viewed by their program managers. This document is a compilation of the papers presented in that special session.				
14. SUBJECT TERMS airframe finite element modeling; rotorcraft airframe vibrations; coupled rotor-airframe vibrations; airframe structural optimization			15. NUMBER OF PAGES 58	
			16. PRICE CODE A04	
17. SECURITY CLASSIFICATION OF REPORT Unclassified	18. SECURITY CLASSIFICATION OF THIS PAGE Unclassified	19. SECURITY CLASSIFICATION OF ABSTRACT	20. LIMITATION OF ABSTRACT	