

**ULTRA-STABLE, LOW PHASE NOISE DIELECTRIC RESONATOR
STABILIZED OSCILLATORS
FOR MILITARY AND COMMERCIAL SYSTEMS**

N93-22179
330-33

150.74

P.7

**Muhammad Mizan, Thomas Higgins, Dana Sturzebecher
Army Research Laboratory, E&PS Directorate,
AMSRL-EP-MA, Fort Monmouth, N.J. 07703-5601.**

ABSTRACT

EPDS has designed, fabricated and tested, ultra-stable, low phase noise microwave dielectric resonator oscillators (DROs) at S, X, Ku, and K-bands, for potential application to high dynamic range and low radar cross section target detection radar systems. The phase noise and the temperature stability surpass commercially available DROs. Low phase noise signals are critical for CW doppler radars, at both very close-in and large offset frequencies from the carrier. The oscillators were built without any temperature compensation techniques and exhibited a temperature stability of 25 parts per million (ppm) over an extended temperature range. The oscillators are lightweight, small and low cost compared to BAW & SAW oscillators, and can impact commercial systems such as telecommunications, built-in-test equipment, cellular phone and satellite communications systems. The key to obtaining this performance was a high Q factor resonant structure (RS) and careful circuit design techniques. The high Q RS consists of a dielectric resonator (DR) supported by a low loss spacer inside a metal cavity. The S and the X-band resonant structures demonstrated loaded Q values of 20,300 and 12,700, respectively.

INTRODUCTION

Systems with stringent performance requirements can benefit from the ultra-stable, low phase noise microwave dielectric resonator oscillators (DROs), at S, X, Ku, and K-bands, reported in this paper. The oscillators, which exhibited excellent temperature stability over extended temperature ranges, were built without any temperature compensation techniques. System designers now have the option of selecting fundamentally operating high frequency DROs without forfeiting critical performance. The key to obtaining this performance was a high Q factor resonant structure (RS) and careful RF circuit design. DROs will play an important role in future military and commercial systems because of their reliability, simple construction, small size, high efficiency, low cost and spurious-free RF output spectrum.

OSCILLATOR DESIGN

The analysis of basic feedback type of circuitry was first given by Leeson.¹ The feedback oscillator configuration allows the circuit designer to isolate low quality or faulty components by measuring the residual noise of the oscillator's components before they are employed in an oscillator circuit. Knowing the magnitude of residual noise of individual components, such as the loop amplifier, resonator and power divider, the absolute phase noise of an oscillator utilizing these components can be estimated.² Because of this advantage, the feedback loop (parallel feedback) oscillator configuration, shown in Figure 1, was chosen. Because of similarities in design, the X-band oscillator design is described in detail with only the performance of the S, Ku and K-band DROs reported, all being summarized in Table 1.

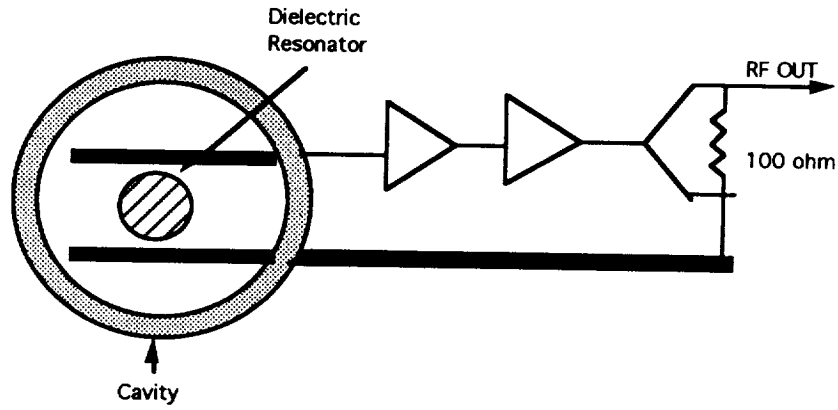

Figure 1. Parallel feedback configuration

DIELECTRIC RESONATOR LOADED CAVITY DESIGN

The cavity dimensions were chosen such that the TE_{010} mode of the resonator was well separated from the cavity modes. Also, the amount of coupling, and the positioning of the dielectric resonator (DR) in the cavity are very critical in obtaining optimum performance. A spacer made of a material with a low dielectric constant was used for mounting the DR inside the cavity, and is shown in Figure 2. Improper mounting will degrade the Q and increase vibration sensitivity.

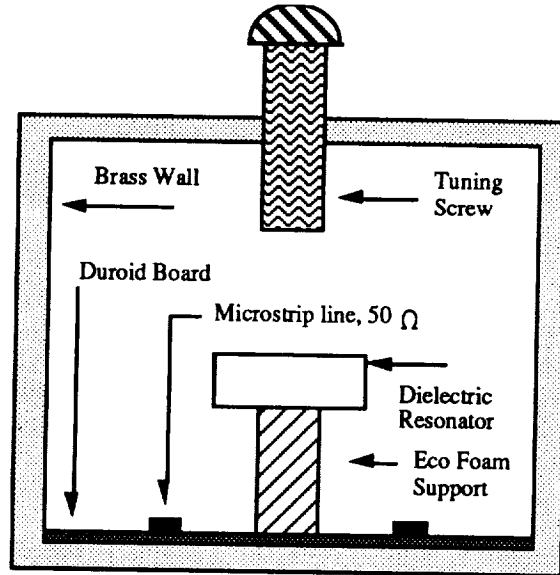

Figure 2. Cavity Configuration

The modes of the cylindrical brass cavity, in the absence of the DR, were analyzed using the cylindrical cavity resonant frequency formulas for TE_{nml} and TM_{nml} , which are given by³:

$$f_{nml} = \frac{c}{2\pi\sqrt{\mu_r\epsilon_r}} \sqrt{\left(\frac{p'_{nm}}{p}\right)^2 + \left(\frac{l\pi}{d}\right)^2} \quad \text{and} \quad f_{nml} = \frac{c}{2\pi\sqrt{\mu_r\epsilon_r}} \sqrt{\left(\frac{p_{nm}}{p}\right)^2 + \left(\frac{l\pi}{d}\right)^2} \quad (1)$$

The calculated modes were then verified by network analysis measurements. Figure 3 shows the air filled cavity mode resonances, which were identified as TE_{111} , TM_{010} and TM_{011} , at 8.765 GHz, 8.985 GHz and 10.415 GHz, respectively. These modes were excited by the 50 ohm microstrip transmission line located at the bottom of the cavity. Shown in Figure 4, is the response of the cavity in the presence of the DR and as expected, the cavity mode resonances shifted lower in frequency. Figure 4 also shows the separation between the $TE_{01\partial}$ mode and the cavity modes. The resonant frequency of the DR was very sensitive to movement of a metal screw, which tunes via fringing field perturbations. Figure 5 shows the behavior of the cavity modes as the tuning screw was plunged into the cavity from the top. The TM_{011} mode was also extremely sensitive to the tuning screw and completely overlaps the $TE_{01\partial}$ mode at some tuning positions. Figure 5 suggests that one has to be very careful with the tuning screw, because carelessness could result in operation on an undesired cavity mode.

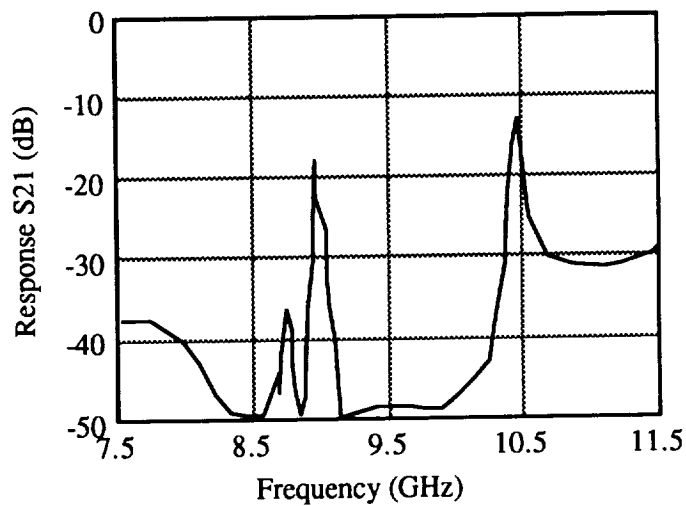

Figure 3. Air Filled Cavity Response

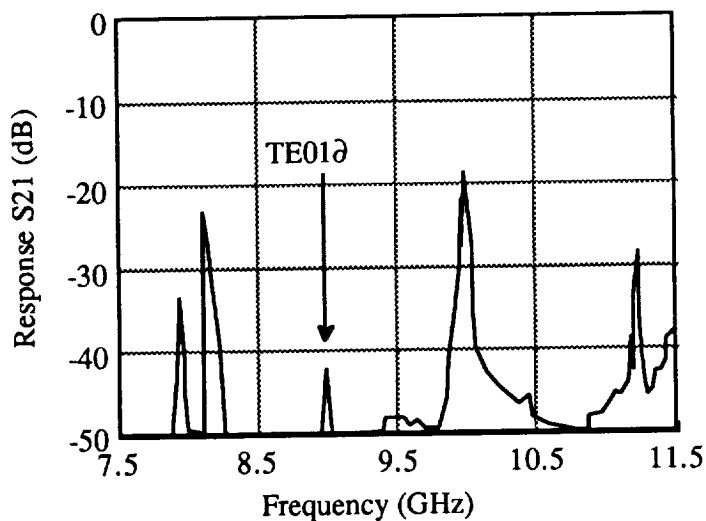

Figure 4. Response of Cavity with DR in Place

The loaded Q measurement for the X-band dielectric resonator is shown in Figure 6, showing a 3 dB bandwidth of 709 KHz at a center frequency of 9.043 GHz, which corresponds to a Q of 12,700. The insertion loss was about 12 dB. Higher loaded Q values were easily attainable by varying the position of the DR, however, at the cost of higher insertion loss. A Q as high as 18,000 was attained at X-band with 20 dB insertion loss, which if used in an oscillator configuration, would have required two additional gain stages to be overcome.

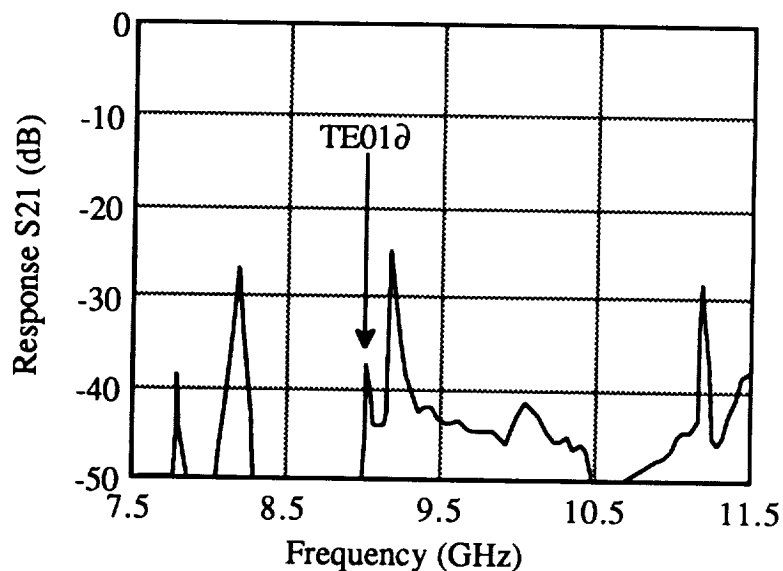

Figure 5. Cavity Response with Tuning Screw Movement

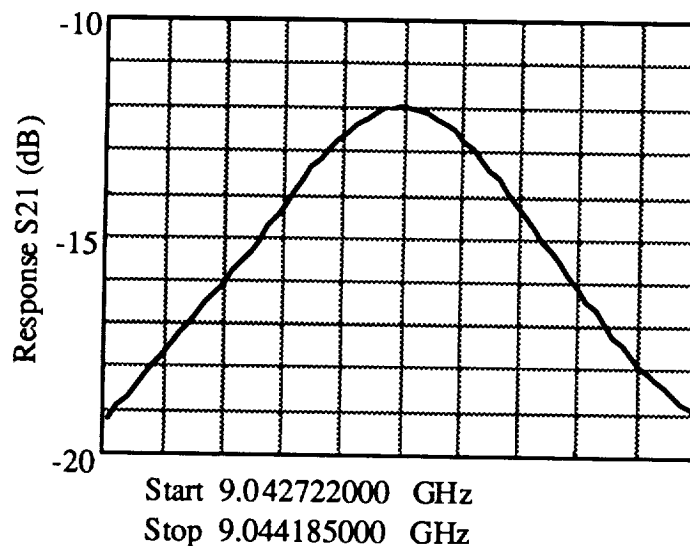

Figure 6. Response of the X-Band Resonant Structure

AMPLIFIER DESIGN

It is well known that bipolar junction transistor (BJT) amplifiers have much lower $1/f$ noise than GaAs MESFET amplifiers, and for this reason the S-band DRO utilized BJTs. At X-band there existed several different choices of active devices. The BJT was eliminated because of the much reduced gain at the higher frequencies, with the other alternatives being HEMTs, HBTs and MESFETs. Several amplifiers utilizing these devices were built and measured to determine which offered the lowest $1/f$ noise. An amplifier employing a Fujitsu FSX52WF MESFET was found to have the lowest $1/f$ noise at X-band, however the same device was unable to be used at Ku-band because of its low gain, so another Fujitsu device was identified for use.

The absolute phase noise of a DRO can be improved either by increasing the loaded Q factor of the RS and/or by lowering the $1/f$ noise of the oscillator's loop amplifier. Since the loaded Q is related to the insertion loss of the RS, additional gain would need to be designed into the loop amplifier in order to achieve higher Q factors, however too many gain stages in the loop amplifier would degrade the overall phase noise due to the addition of $1/f$ noise. A two stage amplifier was found to be the best compromise between a high loaded Q and the number of gain stages. With only one amplifier, the highest Q achievable was approximately 4,000. Whereas with two stages, the achievable Q was approximately 13,000. This is a factor of 3.25 improvement. It should be noted that a 6 dB improvement in overall phase noise is realized by doubling the loaded² Q , while there is only a 3 dB degradation in phase noise because of the added gain stage.

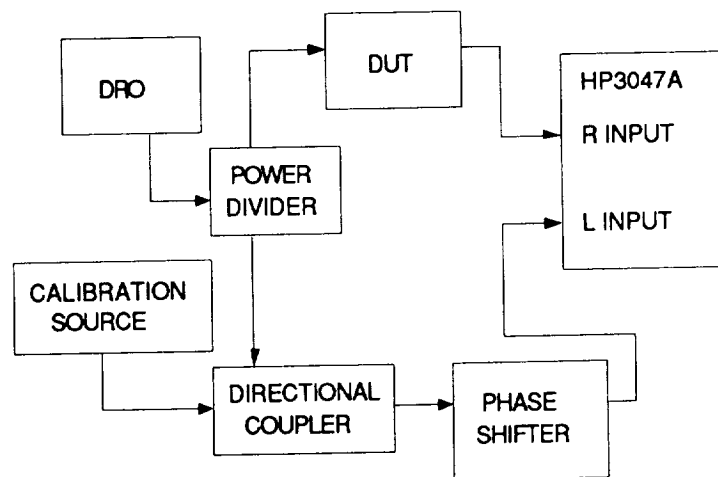

Figure 7. System Used to Measure $1/f$ Noise

The test setup used for measuring the amplifier $1/f$ noise is shown in Figure 7. The system is driven by a low noise DRO in order to get the best system noise floor. The system is capable of detecting a noise level of -140 dBc/Hz at 100 Hz offset from a 9 GHz carrier frequency. The residual phase noise of a single stage Fujitsu MESFET amplifier was measured, and found to be at or below the noise floor of -140 dBc/Hz. The drain bias had a significant effect on the $1/f$ noise, and it was found that the noise level improved as the drain current increased from its normal operating point. The X-band oscillator incorporated two of these amplifiers to overcome the insertion loss of the high loaded Q RS, which thereby offset the noise degradation of the additional gain stage.

The loop amplifiers for the other frequency bands were evaluated in the same manner as for X-band. The residual phase noise ($1/f$ noise) of the S-band BJT amplifier was and found to be at or below a noise floor level of -145 dBc/Hz.

RESULTS

The single side-band absolute phase noise of the 9 GHz two-stage MESFET DRO was measured by downconverting the test DRO to 153 MHz. The down conversion was achieved by mixing the 9 GHz DRO with a high-overtone bulk acoustic resonator (HBAR) oscillator. Then the measurement was made by phase locking the 153 MHz signal to a HP 8662A frequency synthesizer driven from an external 10 MHz VCXO. The measurement configuration is shown in Figure 8. The 9 GHz DRO exhibited a SSB phase noise level of -65 dBc/Hz at a 100 Hz carrier offset frequency, which is an improvement of 6-10 dBc/Hz over previously published data.

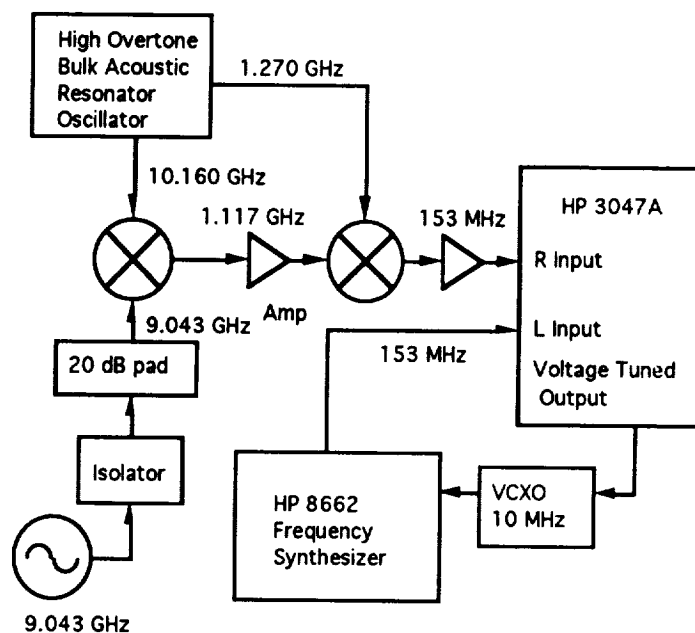

Figure 8. System Used to Measure Absolute Phase Noise

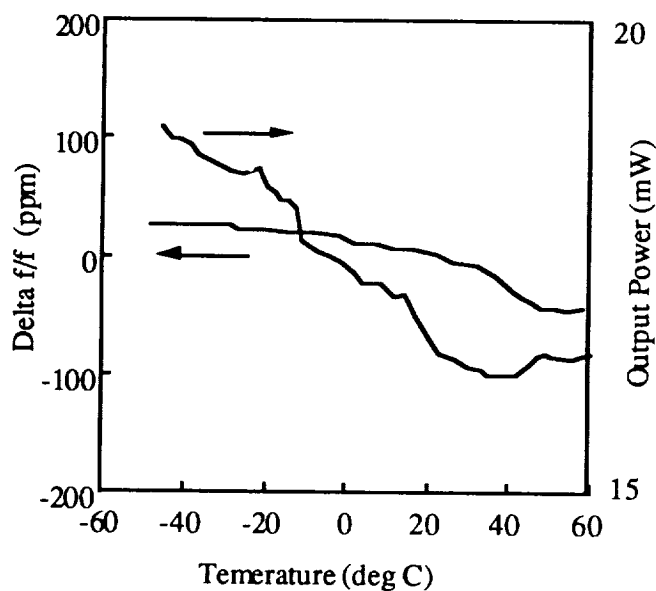

Figure 9. Power & Frequency Variation vs. Temperature of X-Band DRO

Frequency stability and RF output power vs. temperature was measured by using a computer controlled temperature chamber. The DRO was subjected to a temperature profile that began with a 15 minute soak at +55°C and then proceeded to drop at a one degree C per minute from +55°C to -45°C. The total frequency drift of the X-band DRO from -50°C to +20°C was only 25 ppm, and 65 ppm from -50°C to +50°C. Typical RF power output at room temperature was 16.5 mW, and the maximum variation over the full temperature range was 3 mW. The frequency and power vs temperature is shown in Figure 9. The frequency variation with bias voltage (voltage pushing) was found to less than 25 KHz/V over a 4 volt range. The DROs at the other operating frequencies were tested in the same manner, and all the results are summarized in Table 1.

CONCLUSION

Signals with low phase noise are critical for CW doppler radars, at both very close-in and large offset frequencies from the carrier. Design procedures have been presented here which show an improvement over previously published data for temperature stability (for uncompensated DROs) and phase noise.

Band	Frequency (GHz)	Insertion Loss dB	Q_L	Phase Noise @100 Hz dBc/Hz	Phase Noise @1 KHz dBc/Hz	Temp Stability ppm
S	2.091	21	20,300	-97	-127	150
X	9.043	12	12,700	-65	-93	65
Ku	15.900	12	5,800	-40	-70	99
K	24.973	To be determined				45

Table 1. Summary of Measured Results

REFERENCES

- [1] D. B. Leeson, "A Simple Model of Feedback Oscillator Noise Spectrum", Proceedings of the IEEE, Vol. 54, No. 2, pp. 329-330, February 1966
- [2] G. K. Montress and T. E. Parker, "Design Techniques for Achieving State-of-the-Art Oscillator Performance," Proceeding of 44th Annual Symposium on Frequency Control 1990, pp. 522-535. IEEE Catalog No. 90CH2818-3.
- [3] D. M. Pozar, Microwave Engineering Addison Wesley, 1990