

N 03 - 22567

A HYBRID VOICE/DATA MODULATION FOR THE VHF AERONAUTICAL CHANNELS

Dennis M. Akos
Ohio University
Athens, Ohio

SUMMARY

A method of improving the spectral efficiency of the existing Very High Frequency (VHF) Amplitude Modulation (AM) voice communication channels is proposed. The technique is to phase modulate the existing voice amplitude modulated carrier with digital data. This allows the transmission of digital information over an existing AM voice channel with no change to the existing AM signal format. There is no modification to the existing AM receiver to demodulate the voice signal and an additional receiver module can be added for processing of the digital data. The existing VHF AM transmitter requires only a slight modification for the addition of the digital data signal. The past work in the area is summarized and presented together with an improved system design and the proposed implementation.

INTRODUCTION

A system for weather data dissemination to aircraft was developed at Ohio University to improve weather uplink service to general aviation aircraft. This system obtained weather radar reflectivity patterns from the National Weather Service via telephone lines. This image is digitized, the data is compressed, modulated using Quadrature Phase Shift Keying (QPSK), and transmitted over a VHF aeronautical channel. In the aircraft, data is demodulated and processed so that the image can be displayed (ref. 1).

This system offers a potential improvement over the inadequate weather uplink service now in use. The remaining obstacle is in finding a channel in the already overcrowded frequency spectrum. A possible solution may be obtained through the use of a hybrid modulation, utilizing both amplitude and phase modulation on the same channel. Currently, voice communication between the ground and aircraft is accomplished using amplitude modulation of a VHF carrier. This carrier can be phase modulated with digital data such that minimal interference results between the two modulations. This allows reception of the existing AM voice signal with no receiver modification since the signal is transmitted on the carrier in the existing modulation format. The digital data can be extracted using the appropriate processing of this signal.

HYBRID MODULATION

A signal using both amplitude and phase modulation can be expressed by:

$$s(t) = A_c \cdot [1 + k_v \cdot m(t)] \cdot \cos [2\pi f_c t - \Phi(t)] \quad (1)$$

where $m(t)$ is the AM signal, $\Phi(t)$ is the phase modulation (PM) signal, A_c is the amplitude of the carrier, f_c is the carrier frequency, and k_v is the amplitude modulation index. Ideally, these two modulations are independent of one another. However, due to the band limiting necessary for transmission, an interference mechanism is introduced. A phase-modulated signal normally retains a constant amplitude. When this signal is filtered, removing the out-of-band spectral energy,

envelope variations result which will directly interfere with an AM signal (ref. 2). This can be verified by filtering a phase-modulated signal and comparing the envelope of the carrier of the pre-filtered and post-filtered signal. Figure 1 shows a phase modulated carrier while figure 2 shows this signal after filtering with a Butterworth band-pass filter. The plot represents a 10.2-kHz carrier, 200-kHz sampling frequency, Minimum Shift Keying (MSK) phase modulation at a data rate of 2400 bits/seconds, and a tenth order Butterworth filter with a passband extending from 9.0 kHz to 11.4 kHz (All filter transient effects have been truncated for clarity).

The filtered signal experiences envelope variations which would severely distort any additional amplitude modulation. It is necessary to examine further the degradation introduced so that it can be minimized for the implementation of the hybrid modulation.

CHANNEL STUDIES

The hybrid modulation was first studied by Benelli and Fantacci in 1982 and 1983 (refs. 3 and 4) to determine if it could be used to transmit digital information concerning air traffic control to enroute aircraft. A computer simulation was developed to test implementation of the hybrid modulation. The simulation consisted of phase modulating a carrier using random data bits and then amplitude modulating this same carrier with a simulated voice waveform. The signal was then filtered using specifications consistent with typical transmission and reception filters; that is a fourth-order Butterworth with a 3-dB bandwidth of ± 7.5 kHz and an eight-order Butterworth with a 3-dB bandwidth of ± 5 kHz, respectively. Filtering was performed in the frequency domain, with the nonlinear operations, such as modulation and demodulation, simulated in the time domain.

The simulation tested three digital phase modulations: Binary Phase Shift Keying (BPSK), QPSK, and MSK, at data rates between 300 and 2400 bits/second. The results concluded that MSK was the best choice for phase modulation in a hybrid signal. They also concluded that the combination AM-PM MSK provides acceptable performance with an AM signal-to-noise ratio (SNR) of at least 30 dB, up to a data rate of 2400 bits/seconds. The limiting factor on the data rate is the degradation of the voice SNR due to the envelope variation introduced by the removal of the high-frequency energy of the phase modulation. In the case of AM-PM BPSK, the maximum achievable data rate is 600 bits/second and with AM-PM QPSK the maximum is 1200 bits/second. This can be explained by examining the theoretical baseband power spectral densities (PSD) for each of the tested phase modulation methods, shown in figure 3.

As seen in the figure, the power in MSK is concentrated in a more narrow bandwidth than is the case for BPSK or QPSK. As a result, the filtering process eliminates less spectral energy and therefore yields less envelope variation. Likewise, the PSD is more compact for QPSK when compared to BPSK which explains why QPSK outperforms BPSK at equal data rates. Therefore the spectral efficiency of the digital phase modulation is a primary concern in the hybrid signal.

The main criteria used in judging the performance of a system is the degradation of the existing voice signal. This is the principle consideration since the addition of the digital data should be transparent to those using the AM communication channel. It is, however, important to evaluate the bit error rate (BER) of the possible combinations of AM and PM methods. This also was included in the initial work by Benelli and Fantacci (refs. 3 and 4). They concluded that the performance of the data channel is naturally degraded by the presence of the amplitude modulation. This is caused by the need to hard limit the hybrid signal and then filter the resulting waveform to remove the amplitude modulation for recovery of the digital data. They found that using an AM-PM MSK system, the BER degradation for the data channel shows a 2-4 dB loss as compared to the infinite bandwidth and constant envelope case. The 2-4 dB loss was considered an acceptable degradation. It should be noted that their model did not account for possible effects from the

Doppler shift of the carrier due to aircraft dynamics. This Doppler effect will introduce a frequency shift into the carrier which must be considered to ensure the feasibility of the hybrid modulation.

This hybrid modulation concept was also studied by Parker (ref. 1) for its potential as a method to uplink graphical weather information to enroute aircraft. Through analytical and simulation work, he also concluded that acceptable performance could be obtained for a hybrid modulation under the following conditions: (1) digital data transmitted using MSK at a maximum of 2400 bits/second, (2) voice signal transmitted using AM with an index of modulation limited to 0.7, (3) subject to Additive White Gaussian Noise (AWGN), and (4) transmitted and received by VHF AM communication equipment.

IMPROVEMENTS TO THE PROPOSED HYBRID MODULATION

Subsequent to the initial work by Benelli and Fantacci, a number of new continuous constant-amplitude phase modulation methods have been introduced (ref. 5). These methods improve upon MSK with a narrower power spectrum, lower spectral sidelobes, and reduced error probabilities. All of these properties would yield improved system performance in a hybrid modulation.

One such modulation which is becoming increasingly popular is Gaussian Minimum Shift Keying (GMSK), developed by Murota and Hirade for digital mobile radio applications (ref. 6). GMSK incorporates a Gaussian low-pass filter in order to smooth the phase transitions of MSK, thus yielding a narrower PSD by introducing memory into the bit transitions. The roll-off of the filter is adjusted using a parameter known as B_bT , where T is the bit period, and B_b is the 3 dB bandwidth of the Gaussian premodulation filter. Choosing a B_bT value is a tradeoff between spectral economy and receiver complexity. A high B_bT value will result in a very sharp transition band and will confine the phase transition for a single bit to slightly more than a single bit period. It can be shown that as B_bT increases to infinity, the GMSK system actually approaches MSK. A small B_bT value spreads a single phase transition over multiple bit periods, introducing a high degree of intersymbol interference, which requires a complex receiver structure to demodulate. Values of 0.25 and 0.5 for B_bT are becoming standard for the majority of GMSK implementations. The infinite response of the Gaussian filter must be truncated to an integer number of bit periods to provide a functional system.

Figures 4 through 7 compare a MSK signal and phase transitions to the equivalent GMSK signal and phase transition. The parameters for the plots are: carrier frequency of 2 Hz, bit rate of 2 bits/second, B_bT of 0.25 truncated to four bit periods, and the modulating bits 0100110. Both methods require a knowledge of bits beyond the seven modulating bits due to memory requirements. The additional bits are set to binary ones. The GMSK phase path has removed the discontinuities present in the phase path of the MSK signal and thus the spectral efficiency of GMSK is superior to MSK. A closed-form expression for the PSD of GMSK has not yet been derived due to the complexity of the modulation. It is, however, possible to sample a GMSK waveform and estimate the power spectral density using numerical techniques. Applying this to both a MSK and GMSK waveform will allow a comparison to be made. The PSDs are presented in figures 8, 9 and 10 with 95% confidence intervals shown as dashed lines. The plots were produced using a sampling frequency of 19.2 kHz, a carrier frequency of 4.8 kHz, approximately 500 equally likely random data bits, and a bit rate of 2400 bits/second. It is obvious that the spectral efficiencies of GMSK are superior to MSK at both B_bT equal to 0.5 and 0.25. Based on the spectral properties of the digital phase modulations, it would appear that GMSK would be a superior choice for use in the hybrid signal.

A possible problem, not previously considered in the implementation of an AM-PM MSK system, is the ability to maintain a constant carrier frequency in the transmitter. One requirement of a MSK signal is that the carrier frequency must be an exact integer multiple of one-quarter the bit rate ($f_c = n \cdot B_T/4$, where n is an integer). If this requirement is not met, the phase will not be continuous at bit transitions (ref. 7). Using an in-phase/quadrature modulation method to generate the MSK signal will force phase continuity, but will introduce envelope variations which will directly interfere with the AM signal. This is demonstrated in figures 11 and 12 where an MSK signal is generated with a bit rate of 2400 bits/second and carrier frequency of 9 kHz ($n = 15$) and 9.1 kHz ($n = 15.33$).

It follows that the transmitter in an AM-PM MSK must generate a constant carrier frequency to ensure a constant envelope for the AM modulation. For the case of a VHF channel phase modulated using MSK at 2400 bits/second ($n = 600$), the transmitter must hold a stable frequency within ± 50 Hz to ensure acceptable envelope variations. This would require a modification to the existing transmitters which are in use today due to their relaxed stability specifications.

An AM-PM GMSK system is not subject to such strict requirements since the phase transitions for GMSK are continuous due to the memory introduced through filtering. As a result, GMSK is not only more spectrally efficient than MSK, but it is tolerant of typical transmitter drift as well.

AM-PM GMSK SIMULATION

In order to demonstrate the superiority of the AM-PM GMSK system, a computer simulation was developed. Initial work on the GMSK system was concentrated on studying the degradation to the existing voice signal. This is the primary concern for two reasons: 1) the modification to the channel should appear transparent to existing AM users and 2) the BER of the data channel is closely associated with the receiver implementation.

The simulation was based on calculating the mean squared error introduced into the AM voice data by the bandlimiting necessary for transmission of the hybrid signal. The simulation was performed at baseband since the unmodulated carrier is not affected by the filtering process. The hybrid modulated signal given by equation (1) can be transformed into the in-phase and quadrature representation using trigonometric identities:

$$s(t) = A_c [1 + k_v m(t)] [\cos(\Phi(t)) \cos(2\pi f_c t) + \sin(\Phi(t)) \sin(2\pi f_c t)] \quad (2)$$

Again, since the filters are centered about the carrier frequency and no distortion is introduced into the AM signal through the filtering of the carrier, it can be excluded from the simulation. It is, however, important to note that AM interference will be introduced when the carrier frequency is not matched to the bit rate when using MSK to generate $\Phi(t)$. It is now possible to conduct the simulation at the sampling frequency necessary for the AM signal provided the filters are modified accordingly. The resulting baseband signal to be used in the simulation is expressed in equation (3).

$$s_b(t) = A_c [1 + k_v m(t)] [\cos(\Phi(t)) + \sin(\Phi(t))] \quad (3)$$

In addition to the reduced complexity, the removal of the carrier also allows the AM signal, $m(t)$, to be extracted exactly after processing. First, the signal must be factored into the in-phase and quadrature components.

$$s_1(t) = A_c [1 + k_v m(t)] [\cos(\Phi(t))] \quad (4)$$

$$s_Q(t) = A_c [1 + k_v m(t)] [\sin (\Phi(t))] \quad (5)$$

$$s_b(t) = s_I(t) + s_Q(t) \quad (6)$$

The individual components now can be processed separately as each will add distortion to the AM signal. After processing, the resulting AM portion of the signal can be extracted exactly by applying a trigonometric identity, shown in equation (7).

$$A_c [1 + k_v m(t)] = \sqrt{(s_I(t))^2 + \sqrt{(s_Q(t))^2}} \quad (7)$$

Although not true demodulation, the AM signal is recovered with degradation caused only by the addition and filtering of the phase modulation.

It has been determined previously that AM degradation due to MSK is acceptable up to a bit rate of 2400 bits/second. Thus, this system can be used as a reference for testing. The simulation program measures distortion by calculating mean squared error. MSK, GMSK 0.5, and GMSK 0.25 are evaluated at bit rates ranging from 1200 to 5000 bits/second with the results plotted in figure 13. The reference point of 2400 bit/second is marked on the MSK curve as well as the data rates for GMSK 0.5 and GMSK 0.25 which would introduce the same error into the AM signal. The results clearly show that GMSK with either B_bT values is superior to MSK for minimal voice degradation.

PROPOSED IMPLEMENTATION OF A HYBRID SYSTEM

As discussed earlier, existing AM transmitters must be modified to allow for the transmission of the hybrid signal. The required modification is straight-forward, provided that the phase modulation is implemented in the in-phase and quadrature format as presented in equation (2). Using this methodology, the phase modulation can be accomplished by adding an additional component between the generation of the carrier and the amplitude modulation, as presented in figure 14. The boxed component is available on the market as a standard vector modulator. The difficulty remaining is the generation of the $\cos(\Phi(t))$ and $\sin(\Phi(t))$ signals. A similar modulator is presented by Davarian and Sumida (ref. 8) where the actual phase modulation signals, $\cos(\Phi(t))$ and $\sin(\Phi(t))$, are generated using a digital signal processor (DSP) and D/A converters. This is necessary due to the complexity of the phase transitions for GMSK. Currently, an existing VHF AM transmitter at Ohio University is being modified to produce the VHF AM/PM transmitter. The vector modulator is being used with a programmable floating-point DSP to perform the modification. The current DSP program generates approximately 25 data points per bit of the phase modulation signals. This digital signal is processed using an D/A which then supplies the analog signal to the vector modulator.

The BER for the data channel is highly dependent upon receiver design. Although a simple MSK demodulation method will work, the BER can be improved by applying a more sophisticated receiver structure. Receiver design for GMSK has been and continues to be an active area of research. A major reason for this is that GMSK has been chosen by the European Conference of Postal and Telecommunication Administration as the modulation method for the Pan-European Cellular Radio System. Various receiver structures have been proposed and are currently under investigation as to their performance in the hybrid modulation. It is expected that the AM-PM GMSK system should provide superior BER performance. This reasoning is based on the fact that much less of the spectral energy of the phase modulated signal is lost through the filtering process. The GMSK receiver should also prove its superiority in dealing with the presence of a Doppler shift in the receiver carrier, a source of error not fully investigated in the AM-PM MSK model. The receiver models being tested for implementation in the hybrid system are based on those designed for the Pan-European Cellular Radio System which are designed for mobile communications

(refs. 9 and 10). The effects of Doppler shift are minimized through incoherent detection and differential detection. These techniques can be applied to the hybrid system to improve performance.

CONCLUSIONS

The proposed AM-PM GMSK system has shown significant improvements over an AM-PM MSK system in terms of degradation to the existing voice signal and ability to deal with Doppler shift. Current work involves the actual modification of an existing VHF AM transmitter for testing of the hybrid signal in both time and frequency domains. Work has also been initiated on the testing of various receiver models to determine achievable BER for the signal. The AM-PM GMSK system should allow for the transmission of digital data over an existing voice channel. The primary advantage of this system is that the AM signal format is undisturbed and will be transparent to those using the channel only for the reception of the AM signal. The data can be demodulated using a second receiver which will process the same signal to extract the digital information. This not only offers a solution to the placement of the digital weather information channel in the existing spectrum, but opens up a wide range of applications for the transmission of digital data over existing AM channels.

REFERENCES

1. Parker, Craig B.: Weather Data Dissemination to Aircraft. NASA Conference Publication 3063, 1990.
2. Mathwich, H. Robert, Balcewicz, Joseph F., and Hecht, Martin: The Effect of Tandem Band and Amplitude Limiting on the Eb/No Performance of Minimum Shift Keying. IEEE Transactions on Communications, Vol. COM-22, No. 10, October 1974.
3. Benelli, G.: VHF Radio Link for Ground-Air-Ground Communications Using an Integrated Voice-Data Modulation. Electronic Letters, Vol. 18, No. 13, June 24, 1982.
4. Benelli, G. and Fantacci, R.: An Integrated Voice-Data Communication System for VHF Links. IEEE Transactions on Communications, Vol. COM-29, No. 7, December 1983.
5. Sundberg, Carl-Erik: Continuous Phase Modulation. IEEE Communications Magazine, Vol. 24, No. 4, April 1986.
6. Murota, Kazuaki and Hirade, Kenkichi: GMSK Modulation for Digital Mobile Radio Telephony. IEEE Transactions on Communications, Vol. COM-29, No. 7, July 1981.
7. Pasupathy, Subbarayan: Minimum Shift Keying: A Spectrally Efficient Modulation. IEEE Communication Magazine, Vol. 17, No. 4, July 1979.
8. Davarian, Faramaz and Sumida, Joe T.: A Multipurpose Digital Modulator. IEEE Communications Magazine, Vol. 27, No. 2, February 1989.
9. Cavers, James K.: Decision Directed Timing Recovery for Incoherent Detection of GTFM/GMSK. IEEE Vehicular Technology Conference 37th, June 1987.
10. Yongacoglu, A., Makrakis, D., Ohnishi, H., and Feher, K.: New Receiver for Differential Detection of GMSK. IEEE Global Telecommunications Conference, December 1986.

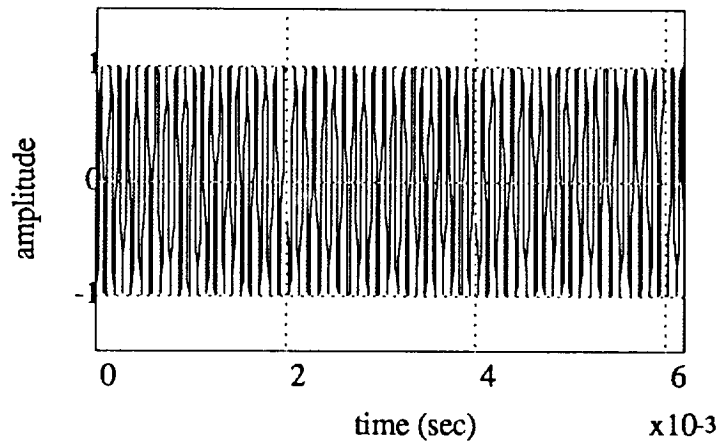

Figure 1. Constant envelope of an unfiltered MSK waveform.

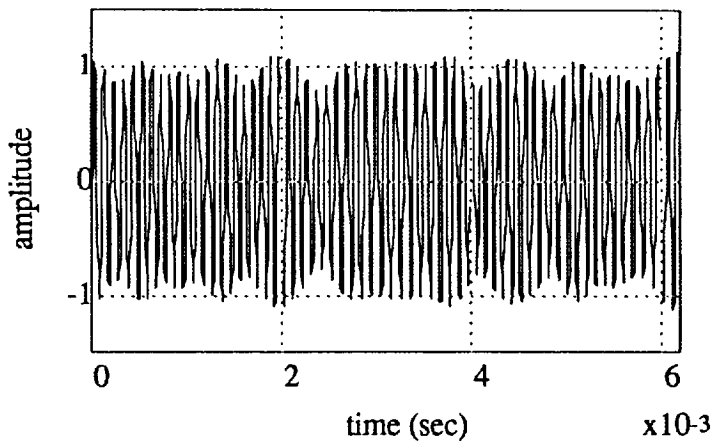

Figure 2. Envelope variations in a MSK waveform as a result of filtering.

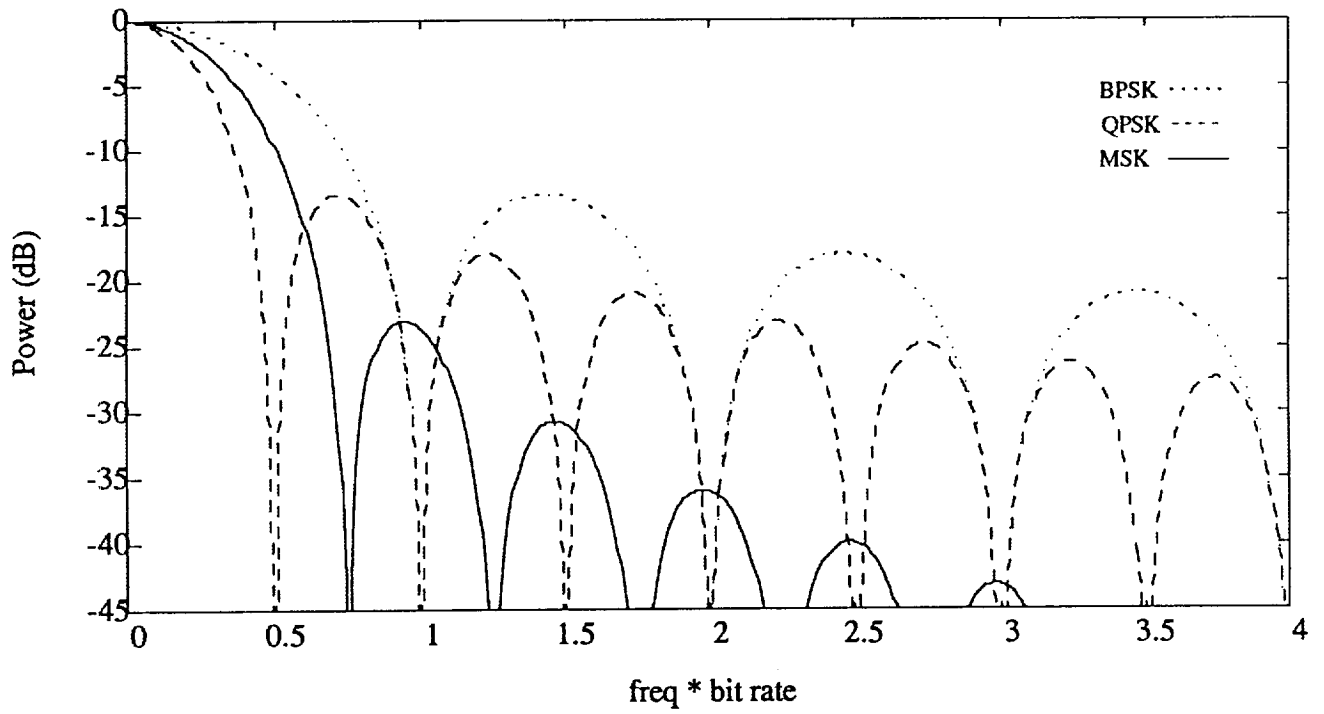

Figure 3. Power spectral densities for BPSK, QPSK, & MSK.

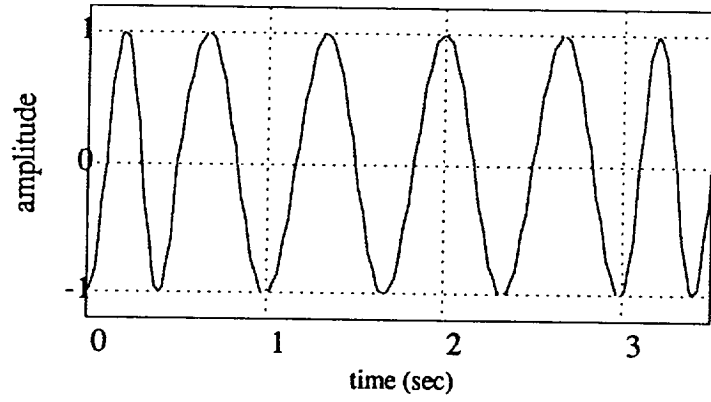

Figure 4. MSK waveform.

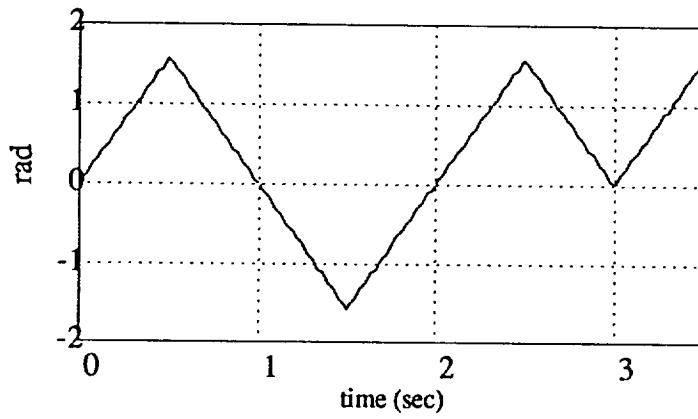

Figure 5. MSK phase transitions.

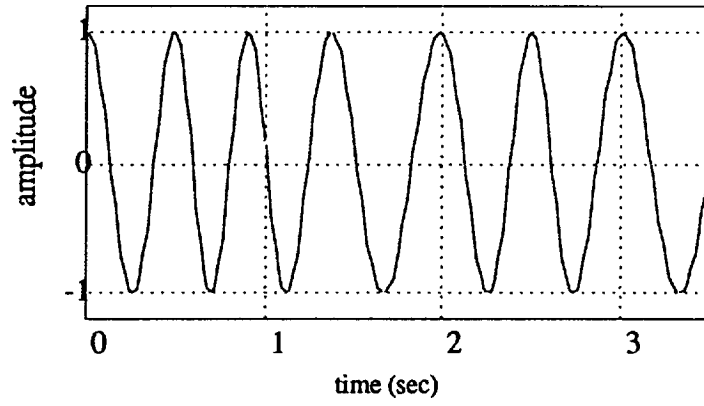

Figure 6. GMSK-0.25 waveform.

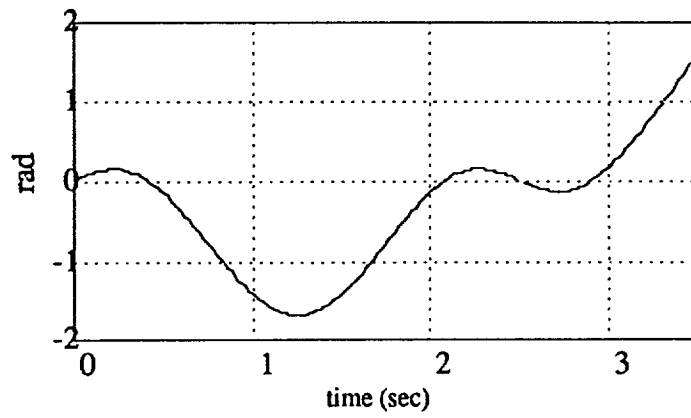

Figure 7. GMSK-0.25 phase transitions.

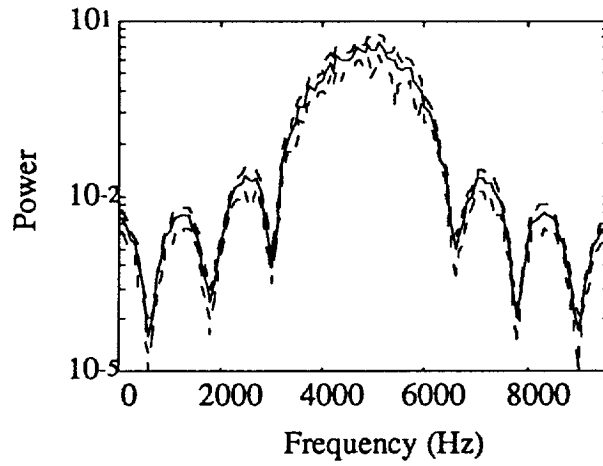

Figure 8. Numerical representation of the PSD for MSK.

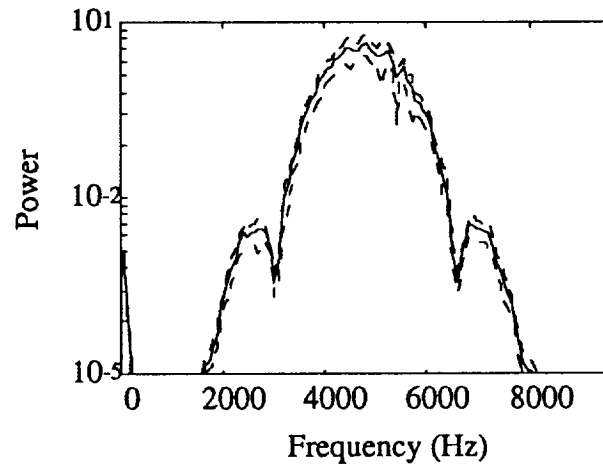

Figure 9. Numerical representation of the PSD for GMSK-0.50.

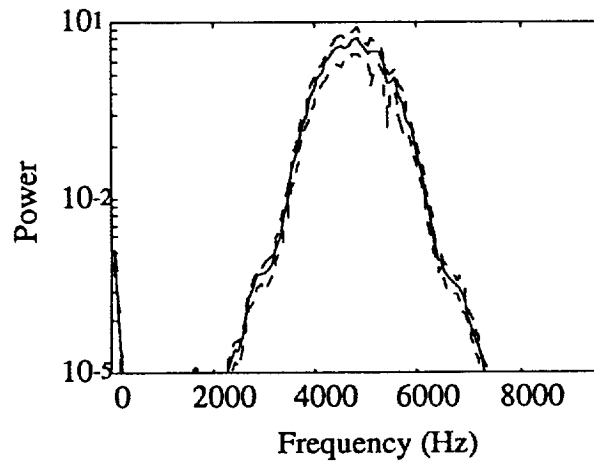

Figure 10. Numerical representation of the PSD for GMSK-0.25.

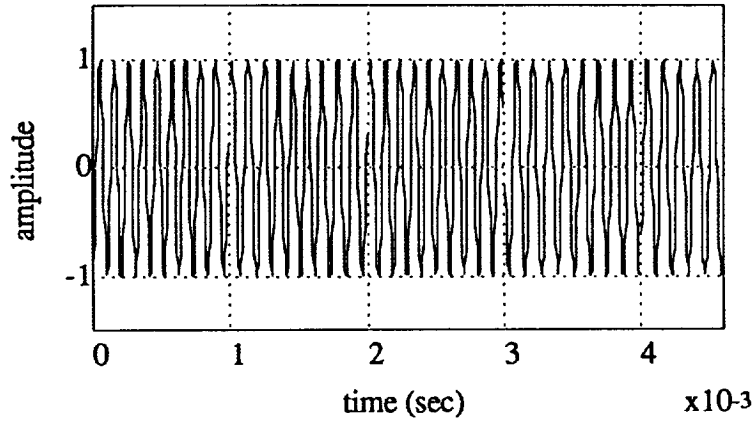

Figure 11. MSK waveform with $f_c = 9$ kHz.

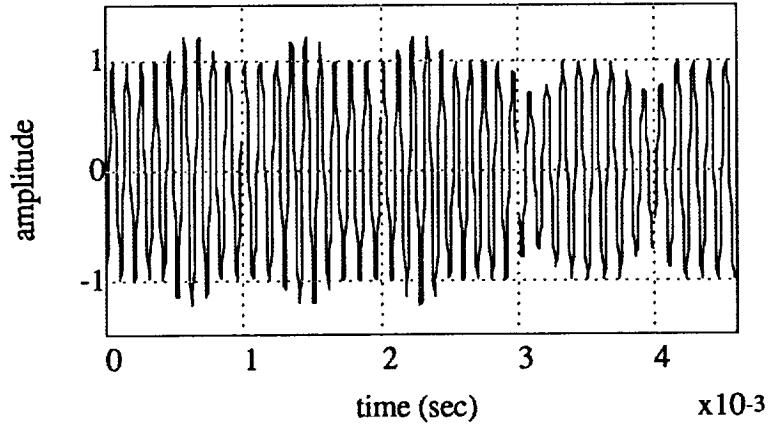

Figure 12. MSK waveform with $f_c = 9.1$ kHz.

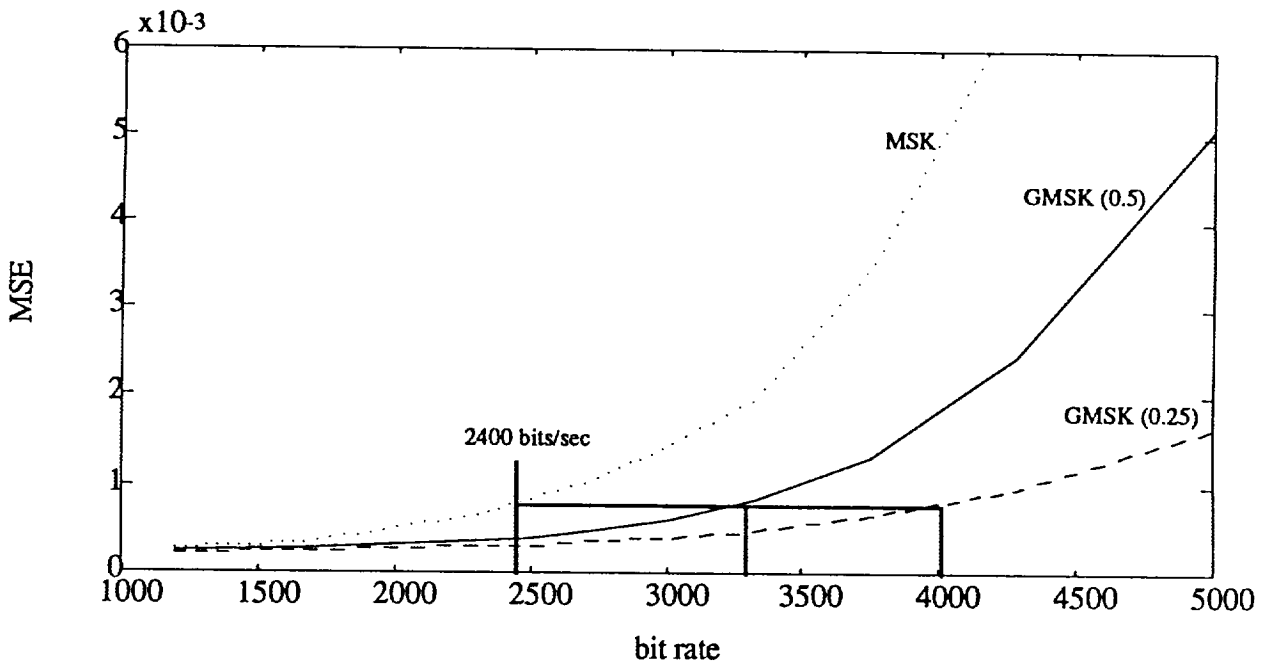

Figure 13. Mean squared error introduced into the AM signal.

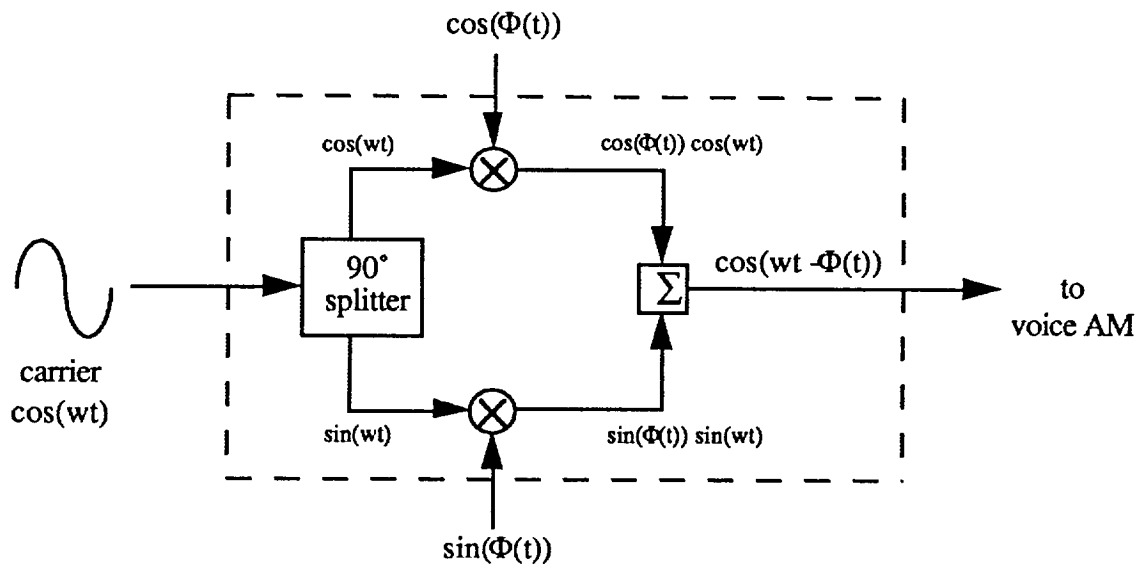

Figure 14. Transmitter modification for hybrid signal generation.

