

N 37
1.1.22
P.128

NASA Contractor Report 191075

Blade Assessment for Ice Impact (BLASIM) User's Manual, Version 1.0

E.S. Reddy and G.H. Abumeri
Sverdrup Technology, Inc.
Lewis Research Center Group
Brook Park, Ohio

April 1993

Prepared for
Lewis Research Center
Under Contracts NAS3-25266



(NASA-CR-191075) BLADE ASSESSMENT
FOR ICE IMPACT (BLASIM). USER'S
MANUAL, VERSION 1.0 (Sverdrup
Technology) 128 p

N93-24102

Unclass

G3/39 0157622

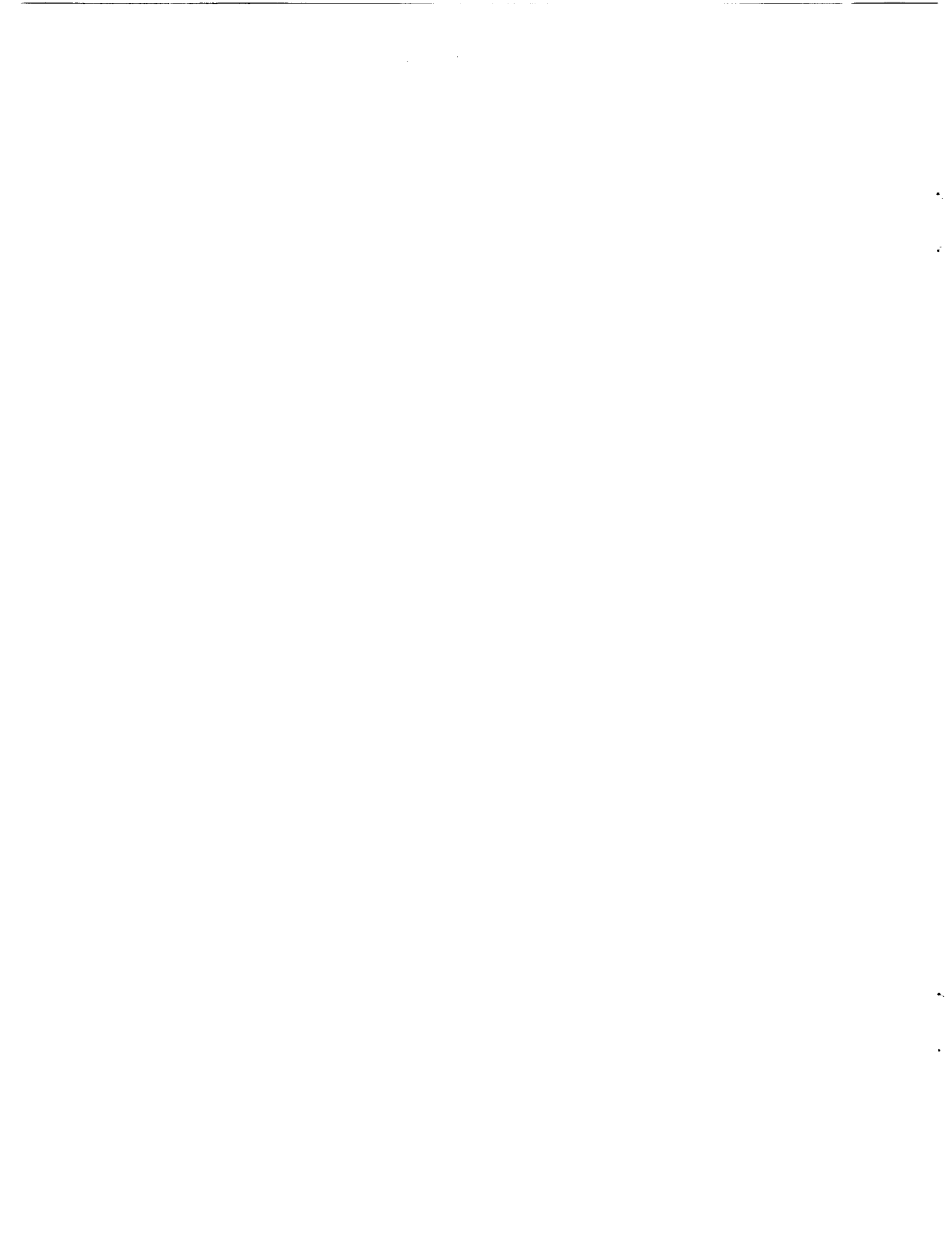

TABLE OF CONTENTS

<u>Section</u>	<u>Page</u>
SUMMARY	
1.0 BLASIM PROGRAM DESCRIPTION	1.1
1.1 Introduction	1.1
1.2 Analyses Capabilities	1.1
1.3 Organization of the Manual.....	1.2
2.0 INPUT FILE GENERATION AND EXECUTION	2.1
2.1 BLASIM Input File Generation	2.1
2.2 Running the BLASIM Code.....	2.9
2.2.1 How to Run BLASIM on VAX.....	2.9
2.2.2 How to Run BLASIM on CRAY XMP.....	2.10
2.2.3 How to Run BLASIM on IRIS Workstation.....	2.11
2.3 Description of Input File	2.11
2.3.1 DATA BLOCK A: Geometry and Analysis Data	2.11
2.3.2 DATA BLOCK B: Approximate Model Input.....	2.22
2.3.3 DATA BLOCK C: Boundary Condition Data	2.45
2.3.4 DATA BLOCK D: Pressure Data.....	2.49
2.3.5 DATA BLOCK E: Fatigue Life Data (Goodman Diagram).....	2.51
3.0 VALIDATION TEST CASES	3.1
3.1 SR3 Propfan Blade Under Centrifugal Loading.....	3.1
3.2 SR3 Propfan Blade Under Uniform Pressure Loading.....	3.4
3.3 SR2 Propfan Blade Under Centrifugal Loading.....	3.8
3.4 Free Vibration Analysis of an SR3 Propfan Blade.....	3.11
4.0 REFERENCES	4.1
APPENDIX A: ICE IMPACT ANALYSIS OF SR-2 BLADE.....	A.1
A.1 Problem Description	A.1
A.2 Input File	A.2
A.3 Output File (Unit 30)	A.8
A.4 Modal Analysis Results (Unit 45)	A.15

A.5	Parametric Study	A.22
APPENDIX B: FIBER-MATRIX OPTION USAGE.....		B.1
B.1	Introduction	B.1
B.2	Interactive Session	B.1
B.3	Input File	B.5
B.4	ICAN Data Bank	B.8

INDEX

LIST OF FIGURES

<u>Figure</u>	<u>Page</u>
1.1. A Schematic of Ice Impact on an Engine Blade	1.2
1.2. Approximate Analysis Modules in the Ice Impact Code	1.3
1.3. General Flow Diagram of the BLASIM Code	1.4
2.1. Ice Impact Input and Output Files	2.1
2.2. Input Blade Details of an Unswept SR-2 Blade.....	2.2
2.3. Definition of Angle ALPHA	2.15
2.4. 1x2y Airfoil Section Coordinate Input.....	2.17
2.5. Finite Element Mesh of the Blade Model.....	2.19
2.6. Blade Root Angle and Neck Description.....	2.20
2.7. Location of the Worst Vibratory and Steady Stress Combination on..... the Modified Goodman Diagram	2.24
2.8. Typical Station Locations for Airfoil Maximum	2.26
Thickness Starting Values	
2.9. Resonance Diagram for a Successfully Tuned Blade.....	2.29
2.10. Geometry of Foreign Object Impact on the Blade.....	2.30
2.11. Local Foreign Object Damage Model.....	2.33
2.12. Unidirectionally Reinforced Lamina.....	2.34
2.13. Dimensions and Layup Associated With a Hollow Blade Design.....	2.37
2.14. Layup Associated with a Superhybrid Blade Design.....	2.38
2.15. Layer Configuration of a Composite Blade.....	2.39
2.16. Dimensions Associated With a Local Increased Density Blade.....	2.43
3.1. Geometry and Finite Element Mesh of the Propfan Blade	3.1
3.2a. Displacements Comparison of BLASIM and MSC/NASTRAN Results.....	3.3
3.2b. Stress Comparison of BLASIM and MSC/NASTRAN Results	3.4
3.3a. Displacement Comparison of BLASIM and MSC/NASTRAN Results.....	3.7
3.3b. Stress Comparison of BLASIM and MSC/NASTRAN Results	3.8
3.4. Finite Element Mesh of the SR2 Composite Propfan Blade	3.8
3.5. Displacements Comparison of BLASIM and MSC/NASTRAN Results.....	3.10

LIST OF FIGURES (Continued)

<u>Figure</u>	<u>Page</u>
A.1. Planform of the SR-2 Unswept Blade with Finite Element Grid	A.1
A.2. Results of Dynamic Analysis for an SR2 Titanium Blade Prior to Ice Impact	A.21
A.3. Results of Dynamic Analysis for an SR2 Titanium Blade After First Ice Impact	A.21
A.4. Variation of Average Leading Edge Strain and Impact Angle with Ice Speed	A.22

BLADE ASSESSMENT FOR ICE IMPACT (BLASIM)

E.S. Reddy and G.H. Abumeri
Sverdrup Technology, Inc.
Lewis Research Center Group
Brook Park, Ohio 44142

SECTION 1.0

BLASIM PROGRAM DESCRIPTION

1.1 Introduction

When aircraft flies through clouds of super-cooled water droplets, ice formation occurs on forward facing structural components. One such components is the engine inlet. With time, the ice accretes on the inlet and eventually sheds due to structural vibrations (Figure 1.1). As a result, blocks of ice traveling at high speed impacts the engine blades rotating at high RPM. This process may cause severe damage to the blade and subsequently to the engine. Hence, it is necessary to assess the damage due to ice impact.

1.2 Analyses Capabilities

BLASIM utilizes a computationally efficient coarse mesh with 55 nodes and 80 triangular plate finite elements. The plate bending element is very similar to the NASTRAN TRIA3 element [1]. Several types of loading are available in the program. The type of loadings are: pressure, temperature, moisture and centrifugal. The analyses types are: local and root ice impact damage, local and root Foreign Object Damage (FOD), static, dynamic, resonance margin calculations, flutter, and fatigue (Figure 1.2). Also, the code can perform these analyses with consecutive (identical) ice impacts with geometry update after each impact. A general flow diagram of the BLASIM code is given in Figure 1.3. The technical details of the analyses used in the code are discussed in Reference [2].

The code can analyze solid, hollow, superhybrid and composite blades. The solid blade is made up of a single material where as hollow and superhybrid blades are constructed with prescribed composite layout. The composite blade can have a maximum of seven different material layers with twenty five composite plies. The properties of a composite blade can be specified by inputting one of two options: individual ply properties or fiber/matrix combinations. When the second option is selected, BLASIM utilizes ICAN (Integrated Composite ANalyzer [3]) to generate the temperature/moisture dependent ply properties of the composite blade.

Two types of geometry input can be given: NASTRAN type finite element grid or airfoil coordinates. This option increases the flexibility of the program. Also, the input to the code can be generated through an interactive process with varied levels of sophistication, i.e., by selecting one of the built in symmetric airfoils at 4 or more stations, or providing user's own finite element grid of the blade through a file.

1.3 Organization of the Manual

Section 2.0 of this manual describes the input generation and execution of the BLASIM program. It includes input data for ice impact analysis example. Section 3.0 lists several validation cases to demonstrate the use and reliability of the code. The references are given in Section 4.0. An example of ice impact and parametric study results are given in Appendix A. The option to use fiber-matrix properties instead of ply properties is demonstrated in Appendix B.

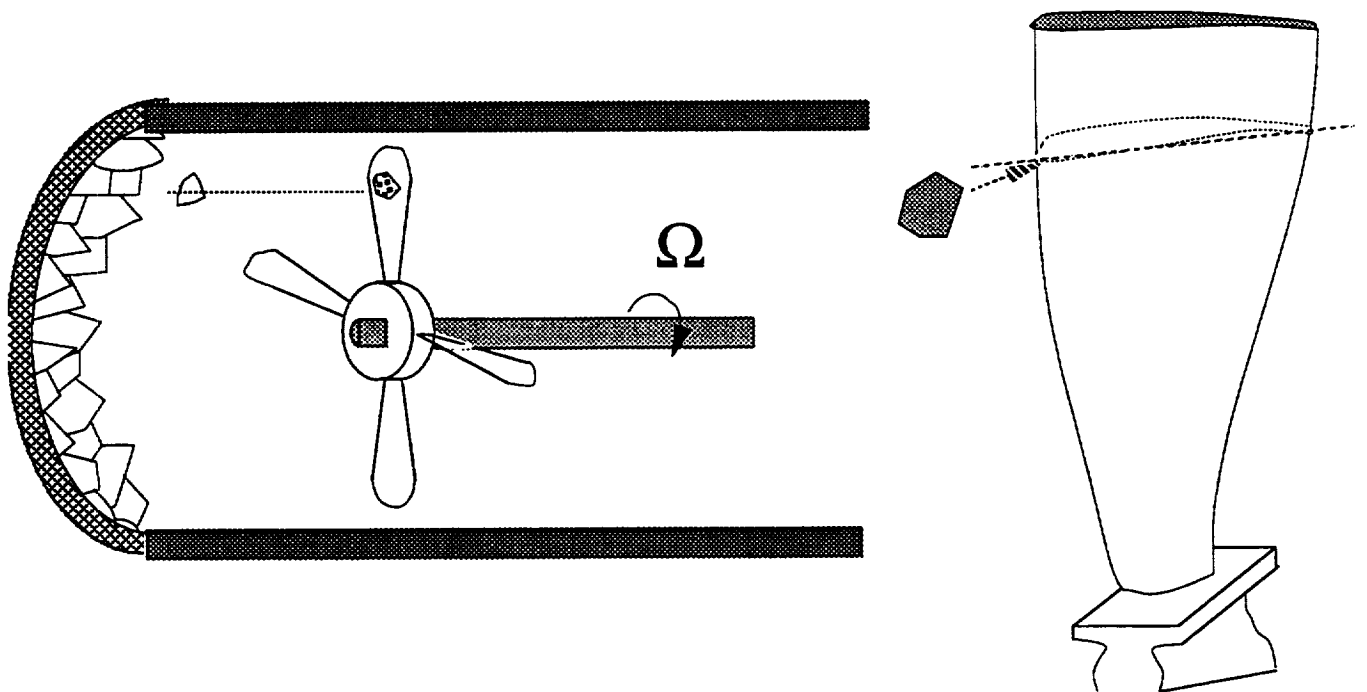

Figure 1.1. A Schematic of Ice Impact on an Engine Blade

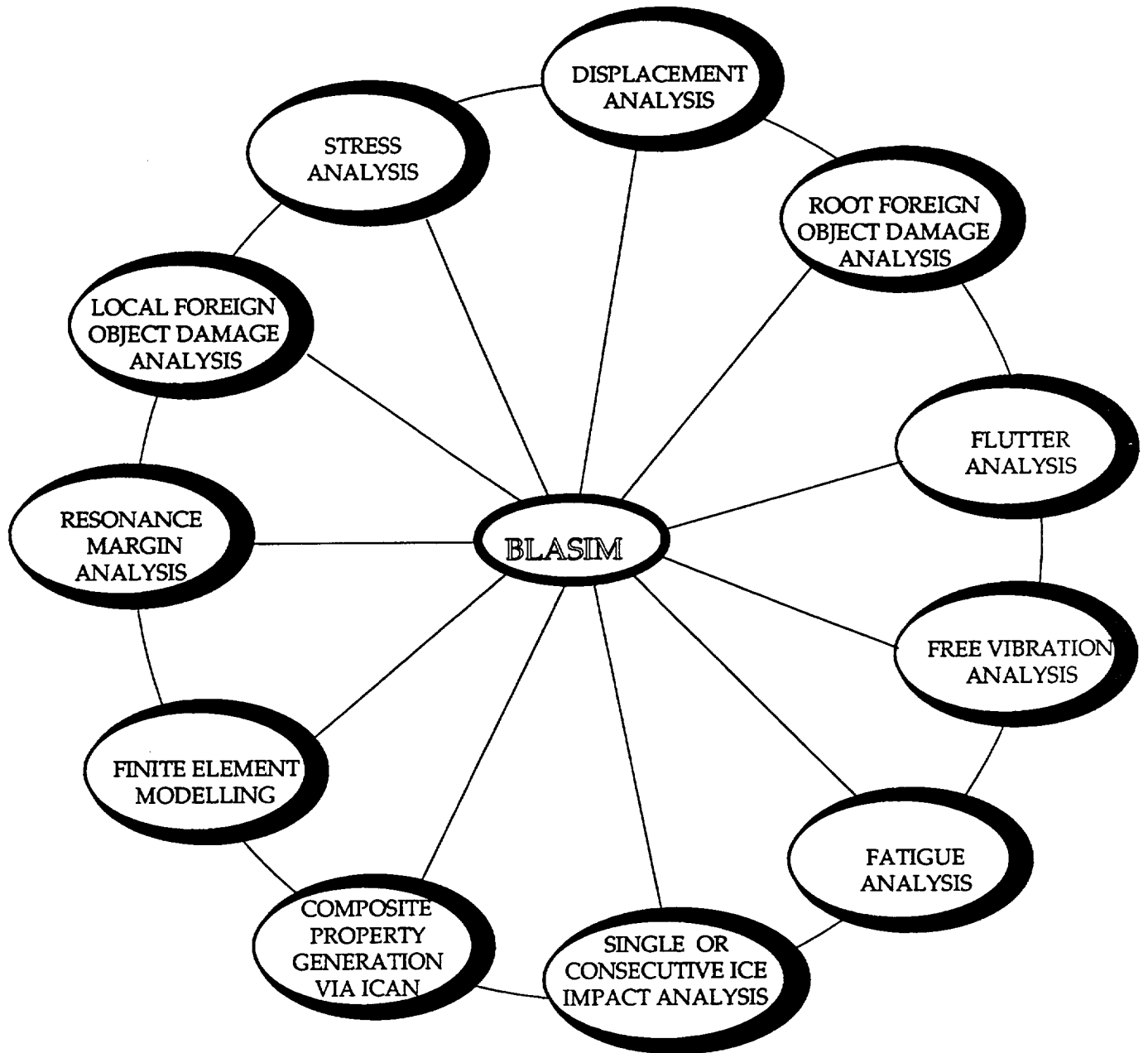

Figure 1.2. Approximate Analysis Modules in the Ice Impact Code

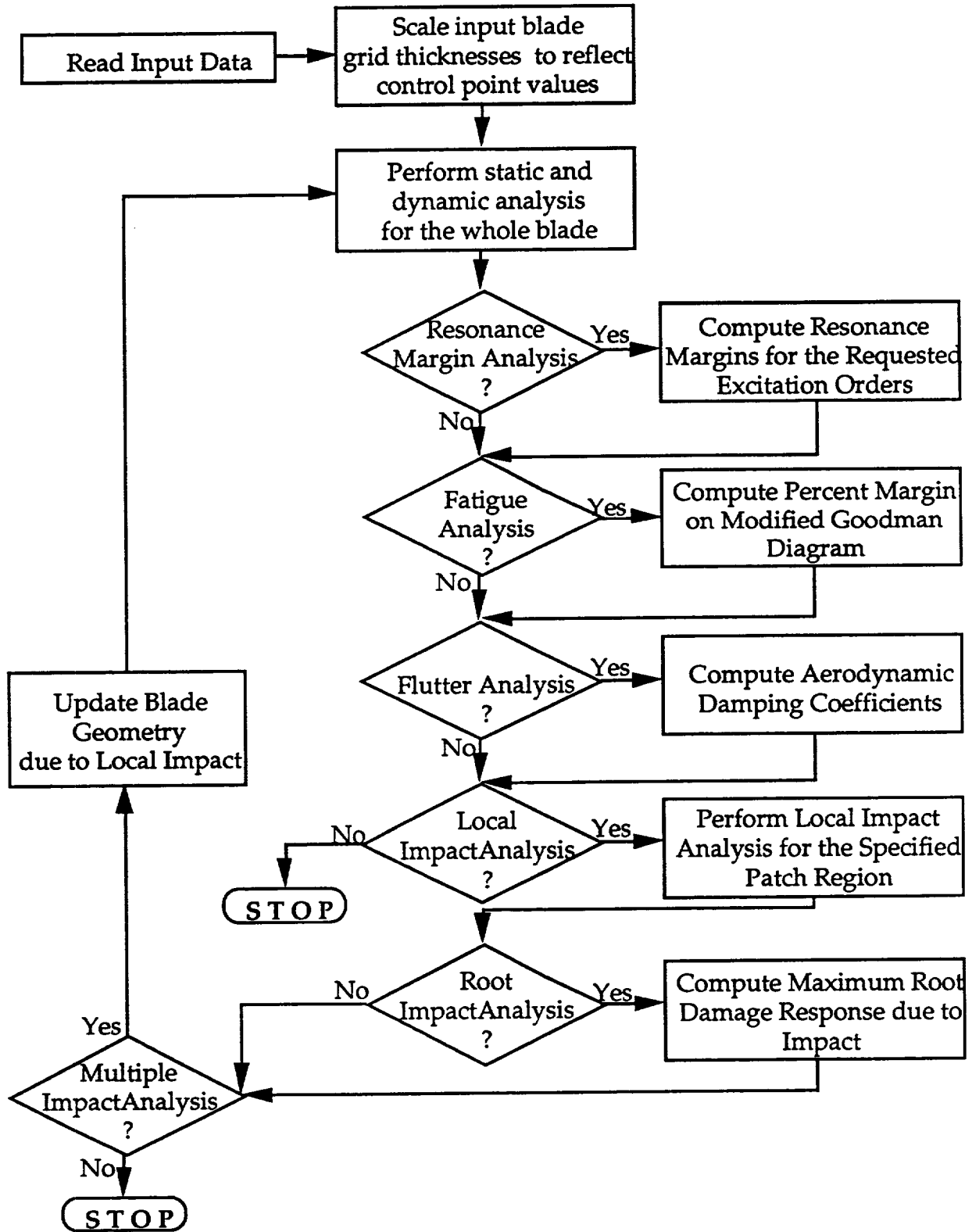

Figure 1.3. General Flow Diagram of the BLASIM Code

SECTION 2.0

INPUT FILE GENERATION AND EXECUTION

2.1 BLASIM Input File Generation

The first step required for using the BLASIM code is to setup an input file. The input and output files needed and generated by the code are shown in Figure 2.1.

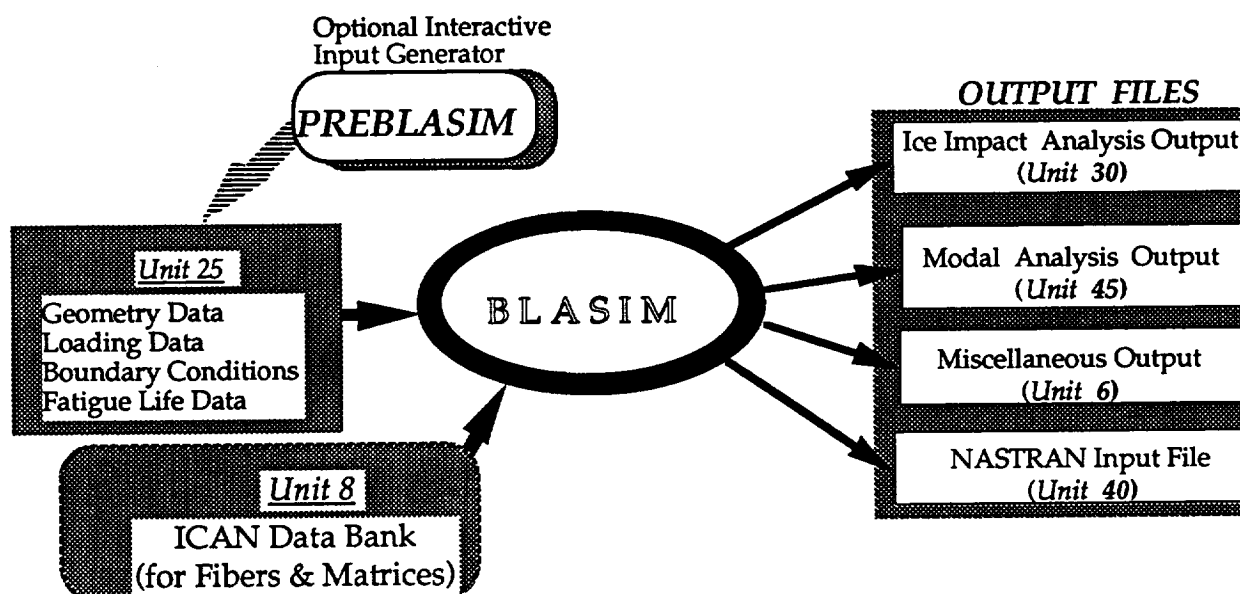

Figure 2.1. Ice Impact Input and Output Files

The input file, *BLASIM.INP*, can be generated either manually or interactively. To construct the data file manually, the format of data blocks described in later sections must be used. Interactive data file generation can be carried out by executing the preprocessor PREBLASIM. The preprocessor is written in FORTRAN and must be compiled and linked as described below depending on the computer system.

<i>System</i>	<i>Compilation</i>	<i>linking</i>
VAX	<i>fort preblasim.f</i>	<i>link preblasim</i>
CRAY	<i>cft77 -dp -ev preblasim.f</i>	<i>segldr -o preblasim.exe preblasim.o</i>
IRIS Workstation	<i>f77 -c -static preblasim.f</i>	<i>f77 -o preblasim.exe preblasim.o</i>

The preprocessor accepts the geometry of the blade in any one of the following three forms:

- (a) NASTRAN type finite element grid input file as described in Section 2.3 (CARD A6a).

The table below summarizes the data that need to be prepared by the user before running the interactive program which generates the BLASIM input file.

Sl. No.	Input Variable	Value	Sl. No.	Input Variable	Value
1	Number of blades:	8	24	Station # 4 stagger angle:	40.1°
2	Blade speed :	3000 rpm	25	Ice piece size:	0.65"x0.65"x0.65"
3	Blade root angle :	-35°	26	Ice velocity :	50 knots
4	Broach angle :	0°	27	Impact region lower limit:	0.5
5	Root thickness:	1.08"	28	Impact region upper limit:	0.9
6	Airfoil type selected:	2	29	Redline speed :	3100 rpm
7	Number of airfoil stations:	4	30	Minimum cruise speed :	2900 rpm
8	Dist. to blade attachment:	2.06"	31	Number of excitation orders:	3
9	Station # 1 radius:	2.778"	32	Excitation numbers:	1 2 3
10	Station # 1 chord length:	1.023"	33	Type of blade (solid):	0
11	Station # 1 thickness(% of chord):	15	34	E ₁₁ :	0.165E+8 psi
12	Station # 1 stagger angle :	3.642°	35	E ₂₂ :	0.165E+8 psi
13	Station # 2 radius:	6.389"	36	Poisson's ratio V :	0.3
14	Station # 2 chord length:	3.65"	37	G ₁₂ :	0.634E+7 psi
15	Station # 2 thickness(% of chord):	15	38	Density of Titanium:	4.4E-4 lb.sec ² /in ⁴
16	Station # 2 stagger angle :	25.53°	39	Blade cross section offsets :	0.0
17	Station # 3 radius:	10.447"	40	Strength X1T in 1-1 :	74000 psi
18	Station # 3 chord length:	3.35"	41	Strength X1C in 1-1 :	74000 psi
19	Station # 3 thickness(% of chord):	15	42	Strength X2T in 2-2 :	74000 psi
20	Station # 3 stagger angle :	36.44°	43	Strength X2C in 2-2 :	74000 psi
21	Station # 4 radius:	12.25"	44	Shear strength in 1-2:	44000 psi
22	Station # 4 chord length:	1.23"	45	Shear strength in 2-1 :	44000 psi
23	Station # 4 thickness(% of chord):	15	46	# of consecutive impacts	1

The interactive session on a VAX computer screen for the sample SR2 blade discussed earlier is listed here. A new user is advised to run PREBLASIM as the interactive process greatly simplifies the input generation.

```

BBBBBB LL      AAAAAA SSSSSS IIIIIIII MM MM
BB BB LL      AA AA SS      II MMM MMM
BB BB LL      AA AA SS      II MM MM MM
BBBBBB LL      AAAAAAA SSSSSS II MM MM
BB BB LL      AA AA SS      II MM MM
BB BB LL      AA AA SS      II MM MM
BBBBBB LLLLLLL AA AA SSSSSS IIIIIIII MM MM

```

Preprocessor for
BLade ASsessment for Ice iMpack

This Module Will Automatically Generate Input File for BLASIM Program. The Blade Geometry May be Defined in One of the Following Forms: a) Provide the Blade Finite Element Nodal Coordinates and their Thicknesses Thru a File, b) Supply the Airfoil Coordinates Thru a File, c) Select one of the Built-in NACA Airfoils. Any Wrong Entries or Defaulted Data May be Changed by Editing the Input File Created by the Program. To Find the Data Card Number, Variable Name and its Description, See Appendix A of the BLASIM User's Manual.

....hit return to continue....

A Summary of the Information Needed to Run the BLASIM Interactive Program is Given Here:

Description of Entry	CARD #
1. Definition of Blade Geometry, Choices are:	
a. Finite element coordinates & Thicknesses	A6a
b. Airfoil Coordinates & Stagger Angles	A6,A7,A8
c. Construction of Blade With Built-in Airfoil Models	None
2. Number of Blades & Operating Speed	A10,A3
3. Blade Root Angle & Thickness, Broach Angle	A9
4. Option for Local & Root Ice Impact Analysis	B1a,B6b
5. Option for Flutter Analysis	B1a,B3,B4
6. Option for Forcing Function Calculation	B1a
7. Redline & Minimum Cruise Speeds	B5
8. Number of Excitation Orders & Order Number	B5
9. Blade Type & Elastic Material Properties	B1a,B8,B11
10. Pressure Data (Optional)	D2
11. Fatigue Life Data (Optional)	E

....hit return to continue....

Enter Title of the Problem :
sr2 modified titanium blade

The terms in Bold are User's Entries

Blade Description and Analyses Options

This is the First Section of the Input File. The Blade Geometry Speed, and Analyses Options are Defined Here. The User is Expected to Provide the Blade Finite Element Nodal or Airfoil Coordinates Thru a Data File or Select an Airfoil Model to Construct the Blade. See the User's Manual For More Details.

Airfoil or Finite Element Input (A/F)? :a
Enter Number of Blades, and Blade Speed (rpm):8 3000
Enter Blade Root Angle (Deg.), Root Thickness, and
Broach Angle (Deg., See Fig. 7 of User Manual):-35 1.08 0.0

Three Airfoil Models are Available for Selection to Construct the Blade Accordingly. These Airfoil Models are Listed Below:

1. NACA 1-series Airfoil with Maximum Thickness Expressed as a Percent of the Chord. The Percentages Allowed are: 6, 9, 12, 15, 18, and 21. The Commonly Used Section of this Family Have Minimum Pressure at 0.6 of the Chord from the Leading Edge and Referred to as NACA 16-series section.
2. NACA Four-Digit Airfoil Model With Maximum Thickness Expressed as a Percent of the Chord. The Percentages that May be Selected are: 6, 9, 12, 15, 18, 21, and 24.
3. NACA 7-series With a Basic Thickness of 15%. The Model Available Here Has a Minimum Pressure at 0.4 of the Chord on Both the Upper and Lower Surfaces.

Do You Want to Construct Your Blade With Any of the Available Airfoil Models? (Enter Yes or No):y

Select the Airfoil Model Desired

Enter 1 for NACA 1-series Airfoil Type
" 2 for NACA Four-Digit Airfoil Type
" 3 for NACA 7-series Airfoil Type:3

Note: A Minimum of 4 Airfoil Stations are Required to Define
----: the Blade. Always, the First Airfoil is the Starting
Station Number at Which Blade Description Begins.
The Last Airfoil is for the Tip Station. The Blade
Attachment is Described Separately.

Enter No. of Spanwise Input Airfoil Stations :4

Enter the Distance from the the Engine Center
to the Blade Attachment :2.06

Enter Chord Length for Blade Station # 1: 1.023

Enter the Angle Between Plane of Rotation of Rotor Stage
and Chord Normal (Degrees) and the Distance From the
Engine Center Line for Blade Station # 1: 3.642 2.778

Enter Chord Length for Blade Station # 2: 3.65

Enter the Angle Between Plane of Rotation of Rotor Stage
and Chord Normal (Degrees) and the Distance From the
Engine Center Line for Blade Station # 2: 25.53 6.389

Enter Chord Length for Blade Station # 3: 3.35

Enter the Angle Between Plane of Rotation of Rotor Stage
and Chord Normal (Degrees) and the Distance From the
Engine Center Line for Blade Station # 3: 36.44 10.447

Enter Chord Length for Blade Station # 4: 1.23

Enter the Angle Between Plane of Rotation of Rotor Stage
and Chord Normal (Degrees) and the Distance From the
Engine Center Line for Blade Station # 4: 40.1 12.25

Do You want to scale the Input Blade Thicknesses
Along the Span (Enter Yes or No):n

Do You Need Local Ice Impact Damage Analysis?
(Enter Yes or No) :y

Do You Need Root Ice Damage Analysis?
(Enter Yes or No) :y

Enter Ice Piece Length, Width, and Thickness (inches) :0.65 0.65 0.65
Enter Ice Velocity (knots) :50

Ice Density is Defaulted to 8.42E-05 (lb.sec**2/in**4)
Enter Density Now or Hit Return to Accept Default Value:
Enter Starting and Ending Ice Impact Location
Along the Span as Fractions for Impact Modelling:0.5 0.9

Enter the Number of Consecutive Ice Impacts
(It Includes Geometry Update Following Each Impact): 1

Do You Need Flutter Analysis?
(Enter Yes or No) :n

Do You Need Resonance Margin Analysis?
(Enter Yes or No) :y

Do you Need Forcing Function Calculated?
(Enter Yes or No) :n

Enter Redline and Minimum Cruise Speeds (RPM) :3100 2900
Enter Number of Excitation Orders (max. 5):3
Enter 3 Excitation Order Nos. (1,2,3, etc.) :1 2 3

Enter Code for Type of Blade Construction
(0:solid; 1:hollow; 2:superhybrid; 3:composite) :0

Enter E11, E22, Nu12, G12, and Density
for Solid Blade:16.5e06 16.5e06 0.30 6.34e06 0.000444

Enter Ultimate Strengths (psi): Tension-11,
Compression-11, Tension-22, Compression-22, and
Shear-12 for Solid Blade:74000 74000 74000 74000 44000

The Blade Offsets are defined as..
x = ACLX*Z + BCLX*Z**2 + CCLX*Z**3

$y = ACLY*Z + BCLY*Z**2 + CCLY*Z**3$
 where Z is spanwise variable
 y is chordwise variable
 and x is transverse variable

The Offsets are Defaulted to Zero, to Accept the Default Values Hit Return or Enter Now ACLX, BCLX, CCLX, ACLY, BCLY, and CCLY:

Pressure Data

This is the Third Section of the Input File Where Pressure Loading Data are Defined. If Pressure Loading is Applied, the User Has the Option of Either Providing Data Thru a File or Entering a Uniform Pressure in This Section. Refer to the User's Manual for Details.

Is there Any Pressure Loading (Enter Yes or No):n

Fatigue Life Data

This Section of the Input File is for Fatigue Data. If Fatigue Analysis is Desired, then Data Such as Static and Dynamic Stress Limits are Entered Here. Refer to the User's Manual for Details.

Do You Need to Enter Fatigue life Data for Forcing Function Calculation? (Enter Yes or No):n

Boundary Conditions Data

Boundary Conditions Data Are Defaulted, i.e., All Degrees of Freedom at the Blade Root are Restrained. To Change the Defaulted Boundary Conditions, Refer to the User Manual, Section 2.0

The Input File Required to Run the BLASIM Code is Generated Under the Name BLASIM.INP. Use the Command or Job File Given in the User's Manual to Run the Code on VAX or CRAY XMP.

Following the interactive session, a file named BLASIM.INP is created. This file is the input to the BLASIM code.

Listing of BLASIM.INP

```

sr2 modified titanium blade
AIRFOIL COORDINATES TYPE                                CARD A2
3000.0                                                    CARD A3
5                                                         2.0          CARD A4
2.060                                                     26           CARD A5
0.000  0.005  0.008  0.013  0.026  0.051  0.077  0.102  0.153CARD A6
0.205  0.256  0.307  0.358  0.409  0.460  0.512  0.563  0.614CARD A6
0.665  0.716  0.767  0.818  0.870  0.921  0.972  1.023          CARD A6
0.000  0.012  0.015  0.018  0.025  0.035  0.042  0.049  0.058CARD A7
0.065  0.071  0.074  0.076  0.077  0.075  0.072  0.067  0.062CARD A7
0.056  0.048  0.040  0.031  0.021  0.012  0.005  0.000          CARD A7
  
```

```

0.000 -0.012 -0.015 -0.018 -0.025 -0.035 -0.042 -0.049 -0.058CARD A8
-0.065 -0.071 -0.074 -0.076 -0.077 -0.075 -0.072 -0.067 -0.062CARD A8
-0.056 -0.048 -0.040 -0.031 -0.021 -0.012 -0.005 0.000 CARD A8
2.778 3.64 26 CARD A5
0.000 0.005 0.008 0.013 0.026 0.051 0.077 0.102 0.153CARD A6
0.205 0.256 0.307 0.358 0.409 0.460 0.512 0.563 0.614CARD A6
0.665 0.716 0.767 0.818 0.870 0.921 0.972 1.023 CARD A6
0.000 0.012 0.015 0.018 0.025 0.035 0.042 0.049 0.058CARD A7
0.065 0.071 0.074 0.076 0.077 0.075 0.072 0.067 0.062CARD A7
0.056 0.048 0.040 0.031 0.021 0.012 0.005 0.000 CARD A7
0.000 -0.012 -0.015 -0.018 -0.025 -0.035 -0.042 -0.049 -0.058CARD A8
-0.065 -0.071 -0.074 -0.076 -0.077 -0.075 -0.072 -0.067 -0.062CARD A8
-0.056 -0.048 -0.040 -0.031 -0.021 -0.012 -0.005 0.000 CARD A8
6.389 25.53 26 CARD A5
0.000 0.018 0.027 0.046 0.091 0.183 0.274 0.365 0.548CARD A6
0.730 0.913 1.095 1.278 1.460 1.643 1.825 2.008 2.190CARD A6
2.372 2.555 2.738 2.920 3.103 3.285 3.467 3.650 CARD A6
0.000 0.044 0.052 0.066 0.090 0.125 0.151 0.173 0.207CARD A7
0.233 0.252 0.265 0.272 0.274 0.267 0.256 0.240 0.221CARD A7
0.199 0.173 0.143 0.110 0.076 0.044 0.016 0.000 CARD A7
0.000 -0.044 -0.052 -0.066 -0.090 -0.125 -0.151 -0.173 -0.207CARD A8
-0.233 -0.252 -0.265 -0.272 -0.274 -0.267 -0.256 -0.240 -0.221CARD A8
-0.199 -0.173 -0.143 -0.110 -0.076 -0.044 -0.016 0.000 CARD A8
10.447 36.44 26 CARD A5
0.000 0.017 0.025 0.042 0.084 0.168 0.251 0.335 0.502CARD A6
0.670 0.837 1.005 1.172 1.340 1.507 1.675 1.842 2.010CARD A6
2.177 2.345 2.513 2.680 2.848 3.015 3.182 3.350 CARD A6
0.000 0.040 0.048 0.060 0.082 0.115 0.139 0.159 0.190CARD A7
0.214 0.231 0.243 0.250 0.251 0.245 0.235 0.221 0.203CARD A7
0.183 0.159 0.131 0.101 0.070 0.040 0.015 0.000 CARD A7
0.000 -0.040 -0.048 -0.060 -0.082 -0.115 -0.139 -0.159 -0.190CARD A8
-0.214 -0.231 -0.243 -0.250 -0.251 -0.245 -0.235 -0.221 -0.203CARD A8
-0.183 -0.159 -0.131 -0.101 -0.070 -0.040 -0.015 0.000 CARD A8
12.250 40.10 26 CARD A5
0.000 0.006 0.009 0.015 0.031 0.062 0.092 0.123 0.185CARD A6
0.246 0.308 0.369 0.431 0.492 0.553 0.615 0.677 0.738CARD A6
0.799 0.861 0.923 0.984 1.046 1.107 1.168 1.230 CARD A6
0.000 0.015 0.018 0.022 0.030 0.042 0.051 0.058 0.070CARD A7
0.079 0.085 0.089 0.092 0.092 0.090 0.086 0.081 0.075CARD A7
0.067 0.058 0.048 0.037 0.026 0.015 0.005 0.000 CARD A7
0.000 -0.015 -0.018 -0.022 -0.030 -0.042 -0.051 -0.058 -0.070CARD A8
-0.079 -0.085 -0.089 -0.092 -0.092 -0.090 -0.086 -0.081 -0.075CARD A8
-0.067 -0.058 -0.048 -0.037 -0.026 -0.015 -0.005 0.000 CARD A8
-35.0 1.080 2.778 0.0 8.0 CARD A9
2 0 5 0 1 1 0 0 1 1.02300 1 CARD A10
.0001.0001.0001.0001.0001.0000 CARD B1a
2 0.1535 5 0.1845 CARD B1b
3100.000 2900.000 3 1 2 3 CARD B2
0.65000 0.65000 0.65000 50.00000 0.000084 0.00001 0.00000 CARD B5
0.50000 0.90000 16 40 1 CARD B6b
0.165E+08 0.165E+08 0.30000 0.634E+07 0.00044 CARD B7
0.0000 0.0000 0.0000 0.0000 0.0000 0.0000 CARD B8
0.740E+05 0.740E+05 0.740E+05 0.740E+05 0.440E+05 0.440E+05 CARD B9e
CARD B11

```

A small section of the output written to FORTRAN logical unit 30 (see Figure 2.1) is shown below:

** * * * * Tip Displacements * * * * *

Max Tip Extension 0.0063
Max In Plane Displ 0.6615 0.3303

* * * * Resonance Margin Information * * * * *

Frequencies At 3000.0 rpm 69.49 227.33 244.48
Frequencies At 3300.0 rpm 75.14 231.24 245.13
Red Line Speed-rpm = 3100.0 Min Cruise Speed-rpm = 2900.0

* * * * Ice Impact Input and Derived Parameters * * * * *

Blade velocity at impact radius 2644.50 in/sec
Ice velocity 1012.69 in/sec (50.00 knots)
Ice equivalent radius 0.40 inch
Local impact reference node 16
Global corresponding impact node 11
Impact radius at reference node 8.42 inch
Impact angle 9.79 degrees
Stagger angle 30.75 degrees
Density 0.840E-04 lbm.sec²/in⁴

* * * * Local Ice Impact Output * * * * *

Maximum Leading Edge Strain % 0.96368E-04
Time Of Occurence 0.19000E-03

2.2 Running the BLASIM Code

The BLASIM code can be run on the VAX, CRAY XMP and IRIS workstation. The procedure required in order to use the BLASIM code on these systems is given in this section.

2.2.1 How to Run BLASIM on VAX

The first step is to compile and link the BLASIM program to create an executable named BLASIM.EXE. The following commands are issued interactively:

```
$ FORT BLASIM          (Compilation command)
$ LINK BLASIM          (Linking command)
```

A command file named *BLASIM.COM* that can be used to run the BLASIM code is listed below:

```

$ ASSIGN BLASIM.INP      FOR025
$ ASSIGN BLASIM.OUT      FOR030
$ ASSIGN  MISCL.OUT     FOR006
$ RUN  BLASIM.EXE
$ DEASSIGN FOR006
$ DEASSIGN FOR025
$ DEASSIGN FOR026
$ DEASSIGN FOR030
$ EXIT

```

The following command is issued to execute the code in the batch mode:

```
$ SUBMIT BLASIM.COM
```

When the execution of the program is completed, the output files, as named in the command file, can be reviewed by the user.

2.2.2 How to Run BLASIM on CRAY XMP

The procedure used here is very similar to the one described in section 2.2.1. The difference here is that a job file named *BLASIM.JOB* is required to be submitted from a front end computer system such as VAX (to CRAY). The listing of *BLASIM.JOB* is given below:

```

# USER=myuserid PW=myuserpwd (Define userid and user password)
# QSUB-r BLASIM (Define the job file name)
# QSUB -nr
# QSUB -nc
# QSUB-q batch
# QSUB-lt 30 (Specify the amount of CPU allowed)
# QSUB-lm 2.0Mw (Specify the amount of memory required)
# QSUB-eo
set -vxk
cd
mkdir impact (Creates a directory called 'impact')
cd impact (Go to the directory impact is available)
ja (Start collecting job statistics)
fetch blasim.f -t'blasim.for' (Fetch BLASIM FORTRAN source code to CRAY)
cft77 -dp -ev blasim.f (Compile BLASIM to create an object file)
segldr -o blasim.exe blasim.o (Link BLASIM to create BLASIM.EXE)
fetch fort.25 -t'blasim.inp' (Fetch BLASIM.INP after preparing it)
blasim.exe > miscl.out (Activate the execution of the code)
dispose fort.30 -t'blasim.out' (Dispose the ice impact information file)
ja -s (print job statistics)
exit

```

Note that the contents in the parenthesis describe the various commands in the job file. The compilation and linking of the BLASIM code is required only the first time the code is used. Afterwards the executable file '*BLASIM.EXE*' can be used every time an analysis run is desired.

2.2.3 How to Run BLASIM on IRIS Workstation

The commands on IRIS workstation are similar to CRAY and are given below.

```
f77 -c -static blasim.f      (Compile BLASIM to create an object file)
f77 -o blasim.exe blasim.o  (Link BLASIM to create BLASIM.EXE)
cp blasim.inp fort.25      (copy BLASIM.INP to FORTRAN unit 25)
blasim.exe > miscl.out     (Activate the execution of the code)
```

2.3 Description of Input File

Due to the modular construction of the BLASIM program, data of the input file has been broken down into five separate data blocks: 1) geometry and analysis data, 2) approximate model input, 3) boundary conditions data, 4) pressure data, and 5) fatigue life data. The pressure data are needed only if there is a pressure loading. Also, the fatigue life data are required in the input file if fatigue analysis is to be performed. The boundary conditions of the blade are defaulted by restraining all degrees of freedom at the root, and they are needed in the input file only if the user decides to modify these conditions. All the types of data discussed above can be included in *BLASIM.INP* either by using the interactive program PREBLASIM or manually. The format and the contents of various data blocks are described below.

2.3.1 DATA BLOCK A: Geometry and Analysis Data

This block contains airfoil coordinate data and other airfoil information, analysis speed, etc.

CARD A1

Contents: Title

1	2	3	4	5	6	7
			ITTLE			
70						
SR-2 UNSWEPT BLADE EXAMPLE						

<u>Field</u>	<u>Item</u>	<u>Format</u>	<u>Description</u>
1-7	ITTLE	A	Descriptive title.

CARD A2

Contents: Geometry Input Mode

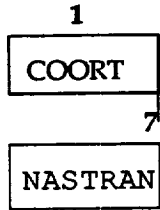

<u>Field</u>	<u>Item</u>	<u>Format</u>	<u>Description</u>
1	COORT	A7	This option specifies the type of geometry desired by the user. Enter: 'NASTRAN' for NASTRAN type geometry or 'AIRFOIL' for airfoil coordinates.

CARD A3

Contents: RPM, No. of Frequencies and RPM Increment

1	2	3	4	5	6
RPM				ROOT	DRPM
8			32	40	48
4000.0				3.0	400.0

<u>Field</u>	<u>Item</u>	<u>Format</u>	<u>Description</u>
1	RPM	F	Analysis speed, RPM. This is the speed desired for flutter stability evaluation.
5	ROOT	F	Number of frequencies desired, maximum of 5.
6	DRPM	F	Delta RPM. This RPM increment is added to the input RPM and another frequency is calculated at the higher speed for the purpose of computing the sensitivity of the natural frequencies to speed. 1000.0 is suggested.

CARD A4

Contents: Blade Station Definition

1	2	3	4	5	6	7	8
NSTA							BRS
2						54	62
11							2.0

<u>Field</u>	<u>Item</u>	<u>Format</u>	<u>Description</u>
1	NSTA	I	Number of spanwise coordinate input stations for blade geometry input description, a maximum of 11 stations can be used.
2	BRS	F	Starting station number at which blade description begins.

CARD A5 (Required if Airfoil Coordinates are used on Card A2)

Contents: Blade Station Radius, Chord Angle, Coordinate Instruction. Input Cards A6, A7 and A7 for Each Blade Station.

1	2	3	4	5	6	7	8	9	10
R				ALPHA					NO
8			26	32				57	61
2.6				3.64					9

Field	Item	Format	Description
1	R	F	Distance from the engine center line to the blade station, inches. The first input station should be the blade attachment, the last the tip station. (Figure 2.6)
5	ALPHA	F	Angle between plane of rotation of rotor stage and chord normal ($y=0$), degrees. (Figure 2.3)
10	NO	F	The number of coordinate stations along the chord used to describe the airfoil profile. Maximum of 53 points. 30-50 are recommended.

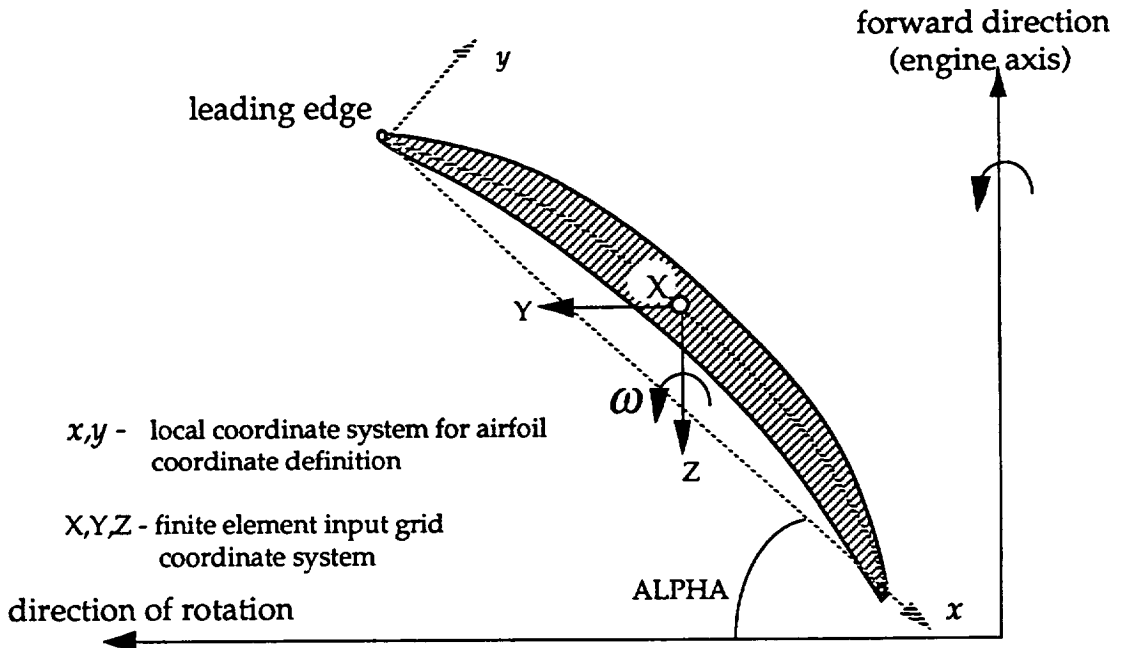

Figure 2.3. Definition of Angle ALPHA

CARDS A6, A7, AND A8 (Required if Airfoil Option is Input on Card A2)

Contents: Airfoil Coordinates

These cards follow Cards A5 at each station. Input x values first, then upper y's, then lower y's (Figure 2.4). For a solid or hollow airfoil with a conventional parallelogram neck geometry to serve as the transition between airfoil root and dovetail attachment, the coordinates of the first station will be ignored. The coordinates for station 1 must be input, however, usually using the station 2 coordinates. BLASIM will build a model of the neck, shown in Figure 2.5, from information included on Card A9. For an airfoil with no platform and a contoured neck, such as the superhybrid blade, the neck is treated as an extension of the airfoil, and thus proper section 1 coordinates are required.

When using the interactive program PREBLASIM which generates BLASIM.INP automatically, the user must prepare the airfoil coordinates in a separate file with a format as indicated below in this card description. If the airfoil generator option in PREBLASIM is used, then the user will not be required to provide this airfoil coordinate file.

	1	2	3	4	5	6	7	8	9
A6:	X(1)	X(2)	X(3)	...					
	8	16	24	32	40	48	56	64	72
A7:	YU(1)	YU(2)	YU(3)	...					
	8	16	24	32	40	48	56	64	72
A8:	YL(1)	YL(2)	YL(3)	...					
	8	16	24	32	40	48	56	64	72
	0.000	0.128	0.256	0.384	0.512	0.639	0.767	0.895	1.023
	0.000	0.103	0.122	0.120	0.108	0.089	0.065	0.036	0.000
	0.000	-0.103	-0.122	-0.120	-0.108	-0.089	-0.065	-0.036	0.000

<u>Field</u>	<u>Item</u>	<u>Format</u>	<u>Description</u>
9 values per card. Fields of 8.	X	F	The x coordinates of the blade cross section given in ascending order for NO points in inches (Figure 2.4).

Start each set on a card.	YU	F	The upper y coordinates of the blade cross section corresponding to the x coordinates in inches (Figure 2.4).
	YL	F	The lower y coordinates of the blade cross section corresponding to the x coordinates in inches (Figure 2.4).

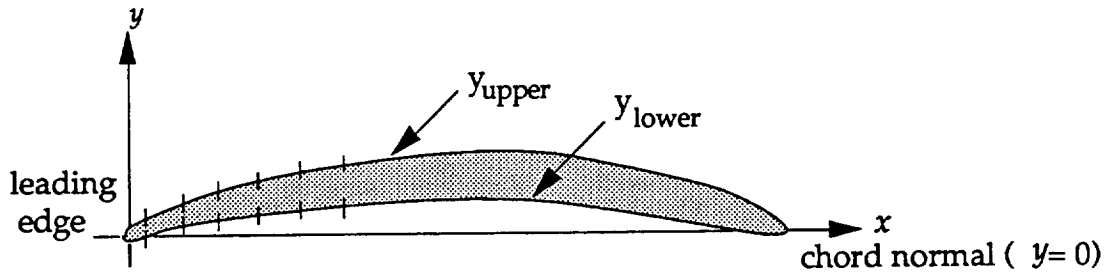

Figure 2.4. 1x2y Airfoil Section Coordinate Input

CARDS A6a, A7a, A8a (Required if NASTRAN Type Geometry is Used, Card A2)

Contents: NASTRAN Blade Geometry Description

This card replaces card A6, A7, and A8. Unlike NASTRAN, BLASIM ignores the mnemonic and assumes that 55 grid cards will follow. Standard NASTRAN format is used.

CARD A6a

When the NASTRAN type coordinates option is selected, the user must prepare an input file with format as indicated below.

1	2	3	4	5	6	7
GRID	N		XN	YN	ZN	THCK
8	16	24	32	40	48	56
GRID	1		2.0600	0.0000	-0.4710	0.7267

<u>Field</u>	<u>Item</u>	<u>Format</u>	<u>Description</u>
1	GRID	A8	not used
2	N	I8	Grid point ID
4 - 6	XGRID(I,J,K)	3F8.5	Grid point coordinates
7	THCK	F8.5	Grid point thickness

Notes:

1. The NASTRAN model used in BLASIM consists of 80 triangular elements. The element connectivity is generated automatically in the code (Figure 2.5).
2. If the interactive input generator PREBLASIM is used to construct the input file *BLASIM.INP*, the NASTRAN grid cards (coordinates) must be made available through a file with a known format (see example in Appendix A).

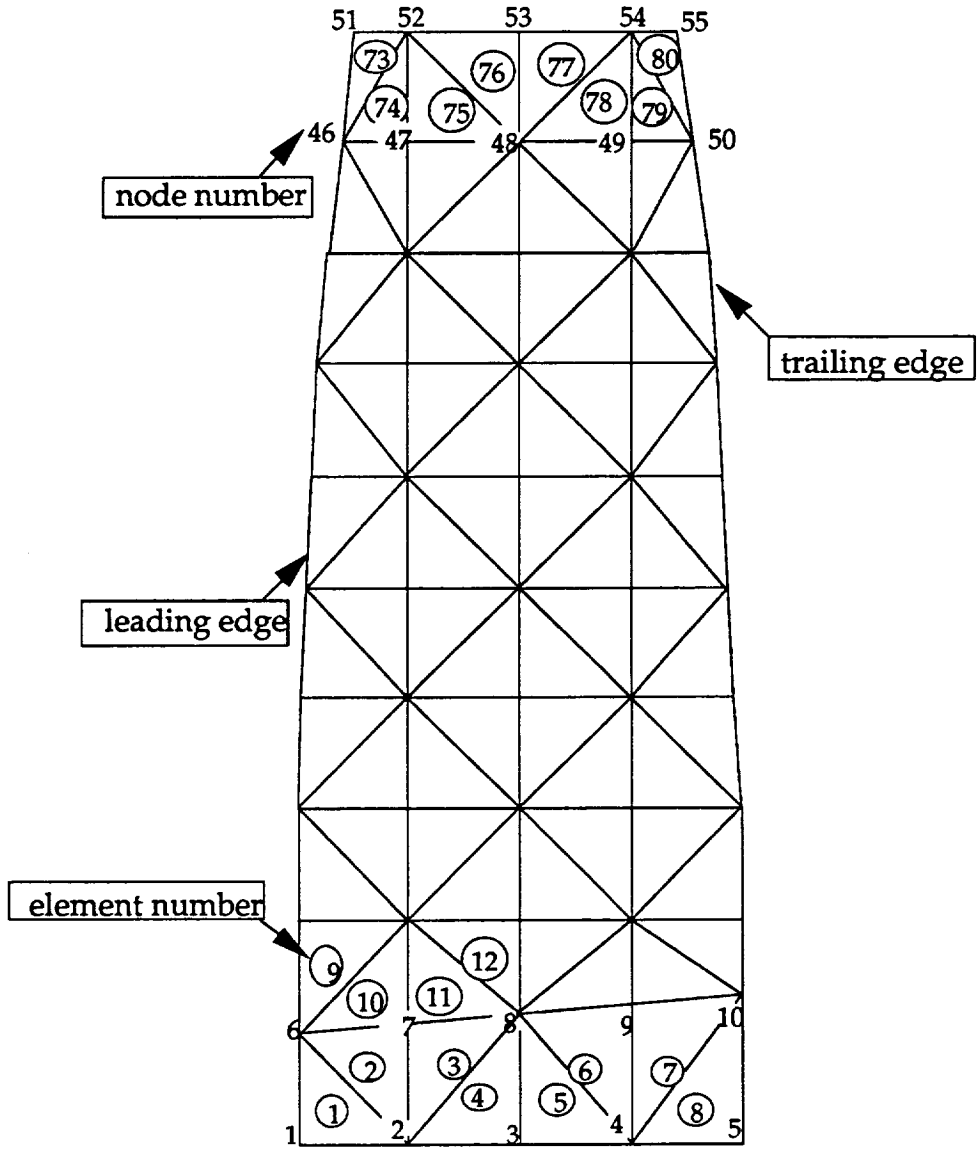

Figure 2.5. Finite Element Mesh of the Blade Model

CARD A9

Contents: Blade Root Angle. Neck Description.
 Card is required but ignored if NASTRAN type geometry is used on Card A2.

1	2	3	4	5
	THER	TROOT	RROOT	BRANG
8	16	24	32	40
	15.0	1.08	2.778	0.0

Field	Item	Format	Description
1	THER	F	Blade root angle, degrees. This is the angle between the blade platform and the engine center line. Positive counterclockwise.
2	TROOT	F	Thickness of blade neck, inches.
3	RROOT	F	Radius of first airfoil station, inches. This radius is the radius at the half-chord point of the airfoil root. RROOT does not have to correspond to an airfoil 1X2Y coordinate input station radius, but must lie between R(1) and R(NSTA).
4	BRANG	F	Broach angle, the angle between the center line of the broach slot and an axial plane, degrees.

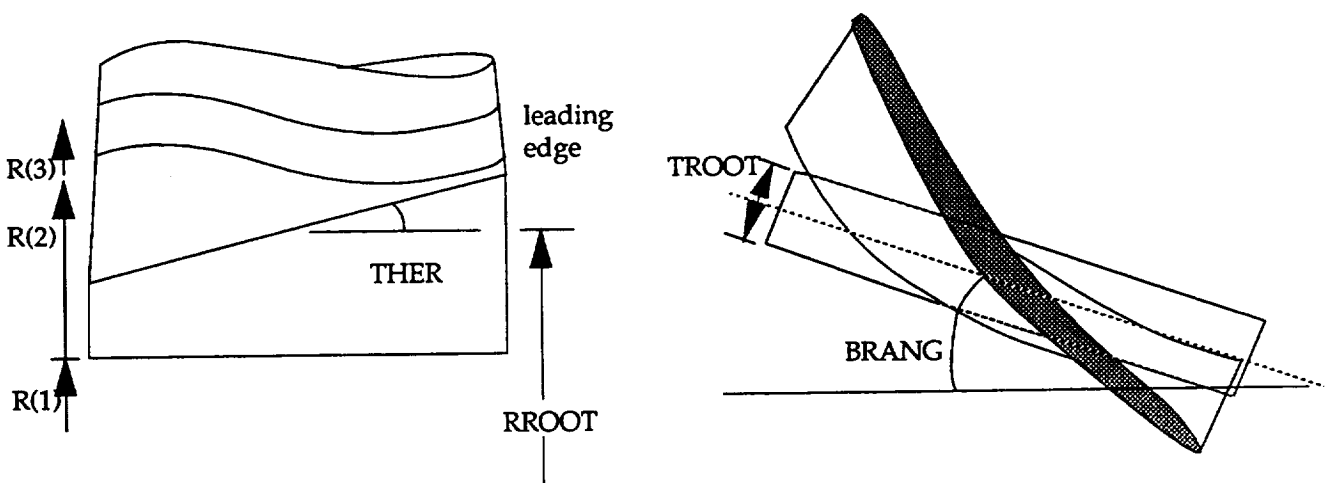

Figure 2.6. Blade Root Angle and Neck Description

CARD A10

Contents: Number of Blades

1	2	3	4	5	6	7
						BLADES
8	16	24	32	40	48	56
						8.0

<u>Field</u>	<u>Item</u>	<u>Format</u>	<u>Description</u>
7	BLADES	F	Number of Blades.

2.3.2 DATA BLOCK B: Approximate Model Input

This block contains additional approximate model input, scaling factors for geometry, etc.

CARD B1a

Contents: Problem Definition

1	2	3	4	5	6	7	8	9	10	11
NTIS	NRF	NRFOD	NCD	NLAYER	NRTFOD	NRESFF	NTIPMD	ICEPACT	BRSV	INDFL
5	10	15	20	25	30	35	40	45	55	60
5	0	5	0	1	1	0	0		1.02307	1

<u>Field</u>	<u>Item</u>	<u>Format</u>	<u>Description</u>
1	NTIS	I	Number of thickness input stations, maximum of 11, minimum of 2. Suggested value is 5.
2	NRF	I	Number of roots calculated by flutter analysis, maximum of 5.
3	NRFOD	I	Number of roots for both local and root foreign object damage (FOD) analysis. Suggested value is 5. If = 0, FOD/Ice Impact analysis is not made.
4	NCD	I	Defines the blade type: = 0: solid (isotropic/orthotropic) = 1: hollow = 2: superhybrid = 3: composite
5	NMATRL	I	Number of layers for blade. If NCD=0: enter 1 If NCD=1: enter 2 If NCD=2: enter 4 If NCD=3, NMATRL is the number of constituents in the composite (maximum of 7).
6	NRTFOD	I	Root foreign object damage option: = 0: not calculated = 1: calculated

7	NRESFF	I	Resonance margin criteria: = 0: resonance margins calculated = 1: forcing function calculated = 2: both of the above
---	--------	---	---

Notes:

1. Excitation orders for which margins are calculated are input on Card B5.
2. If NRESFF=1, minimum resonance margin will be based on maximum permissible vibratory and steady stress combination on the blade which satisfies the Modified Goodman Diagram (Figure 2.7).
3. When NRESFF=2, the limiting case (either the specified resonance margin or maximum permissible blade stress) will govern.

8	NTIPMD	I	Tipmode search (required if a tip plate vibratory mode constraint is desired):
---	--------	---	--

= 0: no search
 = 1: number of modes tested for tip (5 maximum)
 Note: if NTIPMD > 0 and no tipmodes are found, tipmode defaults to fifth mode.

9	ICEPACT	I	= 0: ice impact analysis is not performed. = 1: ice impact analysis performed.
---	---------	---	---

10	BRSV	F	Root chord length for which optimization will begin, inches. All coordinate input will be scaled by BRSV/coordinate input root chord.
----	------	---	---

11	INDFL	I	Index for failure criterion selection: = 1: Modified Distortion Energy (MDE) criterion = 2: Hoffman failure criterion
----	-------	---	---

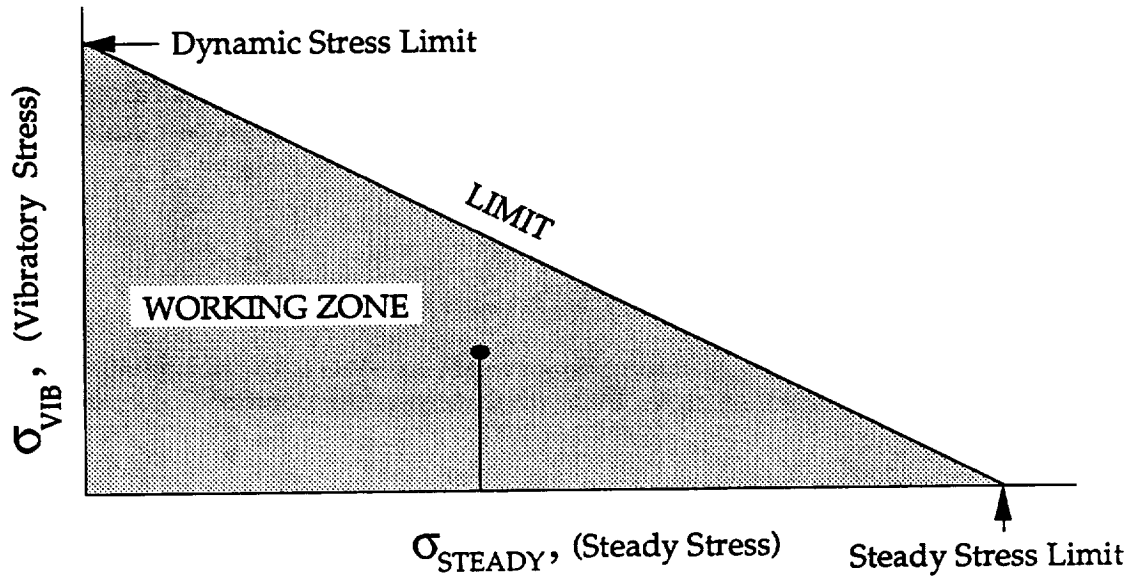

Figure 2.7. Location of the Worst Vibratory and Steady Stress Combination on the Modified Goodman Diagram

CARD B1b

Contents: Frequency Correction Factors

1	2	3	4	5	6
CF1	CF2	CF3	CF4	CF5	CFT
5	10	15	20	25	30
1.000	1.000	1.000	1.000	1.000	1.000

<u>Field</u>	<u>Item</u>	<u>Format</u>	<u>Description</u>
1	CF1	F	First mode correction factor. Default = 1.0. $CF = \frac{\text{Refined Analysis Frequency}}{\text{Approximate Analysis Frequency}}$
2	CF2	F	Second mode correction factor. Default = 1.0.
3	CF3	F	Third mode correction factor. Default = 1.0.
4	CF4	F	Fourth mode correction factor. Default = 1.0.
5	CF5	F	Fifth mode correction factor. Default = 1.0.
6	CFT	F	Tipmode correction factor. Default = 1.0.

CARD B2

Contents: Airfoil Coordinate Input in Data Block A Will be Scaled to Reflect These Starting Values of Maximum Thickness.

1	2	3	4	NTIS times							
IST(1)	VALT(1)	IST(2)	VALT(2)							
2	10	12	20								
2	0.8927	5	0.1447	7	0.0837	9	0.0576	11	0.0336		

Field	Item	Format	Description
1	IST(1)	I	Station number (as referenced to Block B).
2	VALT(1)	F	Thickness, inches.

Alternate NTIS Times

Note: IST(NTIS) must correspond to the blade tip.

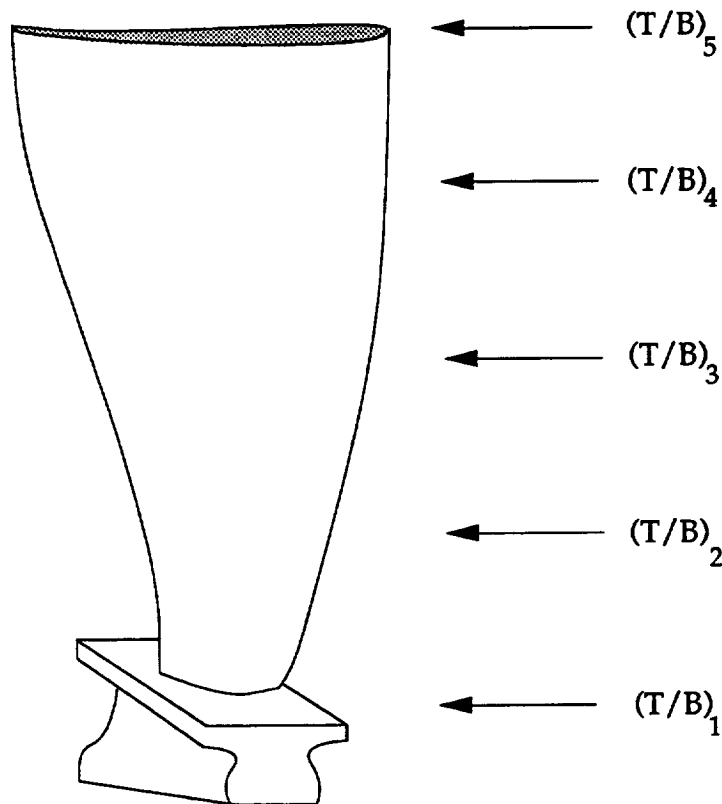

Figure 2.8. Typical Station Locations for Airfoil Maximum Thickness Starting Values

CARD B3 (Required If NRF > O on Card B1a)

Contents: Supersonic flutter analysis input control.

1	2	3	4
	TEMPST		NAC
10	20	35	40
	100.0		1

<u>Field</u>	<u>Item</u>	<u>Format</u>	<u>Description</u>
2	TEMPST	F	Inlet static temperature, °F.
4	NAC	I	Number of aerodynamic stations. Note: At present, only one station is allowed.

CARD B4 (Required If NRF > 0 on Card Bla)

Contents: Aerodynamic Data for Flutter Calculation. Input NAC Times.

1	2	3	4
VOM(I)	ARAD(I)		STPRS(I)
10	20	30	40
2.0	12.25		14.0

<u>Field</u>	<u>Item</u>	<u>Format</u>	<u>Description</u>
1	VOM(I)	F	Relative Inlet Mach Number (strictly > 1.0).
2	ARAD(I)	F	Corresponding radius in inches.
3	STPRS(I)	F	Inlet static pressure, lbf/ft ² .

CARD B5

Contents: Speed and Excitation Orders for Resonance Margin Calculation

1	2	3	4	5	NORD times	
SPDRL	SPDMC	NORD	IOR(1)	IOR(2)	
10	20	25	30	35		
4100.0	3900.9	3	1	2	3	

Field	Item	Format	Description
1	SPDRL	F	Redline speed, RPM.
2	SPDMC	F	Minimum cruise speed, RPM.
3	NORD	I	Number of excitation orders input, maximum of 5.
4	IOR(I) I = 1, NORD	I	Order number.

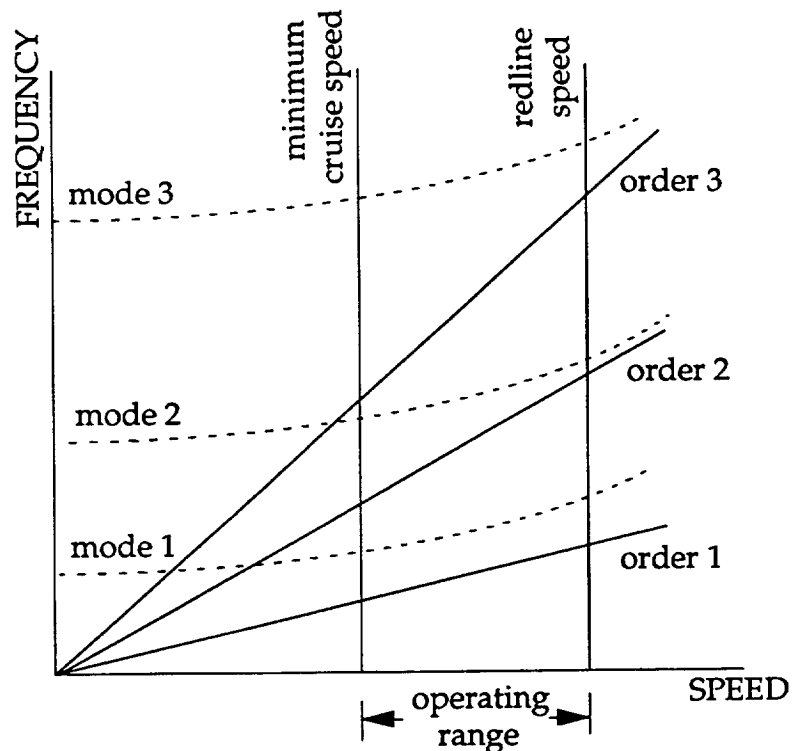

Figure 2.9. Resonance Diagram for a Successfully Tuned Blade
(No Response Crossings Within 5 Percent of the Speed
Operating Range)

CARD B6a (Required If NRFOD > 0 and ICEPACT=0 on Card Bla)

Contents: Local Foreign Object Damage Input

1	2	3	4	5	6
R	VP	THETA	RHO	TSTEP	BETA
10	20	30	40	50	60
0.5	2000.0	30.0	0.000076	0.00001	0.0

Field	Item	Format	Description
1	R	F	Bird radius, inches.
2	VP	F	Bird velocity, inches/sec.
3	THETA	F	Impact angle relative to ALPHA on Card B5, radians (see Figure 2.10). THETA can be calculated as follows: $\text{THETA} = \text{ALPHA (at impact radius)} - \Phi$ where $\Phi = \text{TAN}^{-1}((60 * V_P) / (2\pi * \text{blade impact radius} * \text{RPM}))$.
4	RHO	F	Bird density, lb.sec ² /in ⁴ .
5	TSTEP	F	Timestep, in seconds. 1x10 ⁻⁵ recommended.
6	BETA	F	Modal damping, 0.0 is recommended.

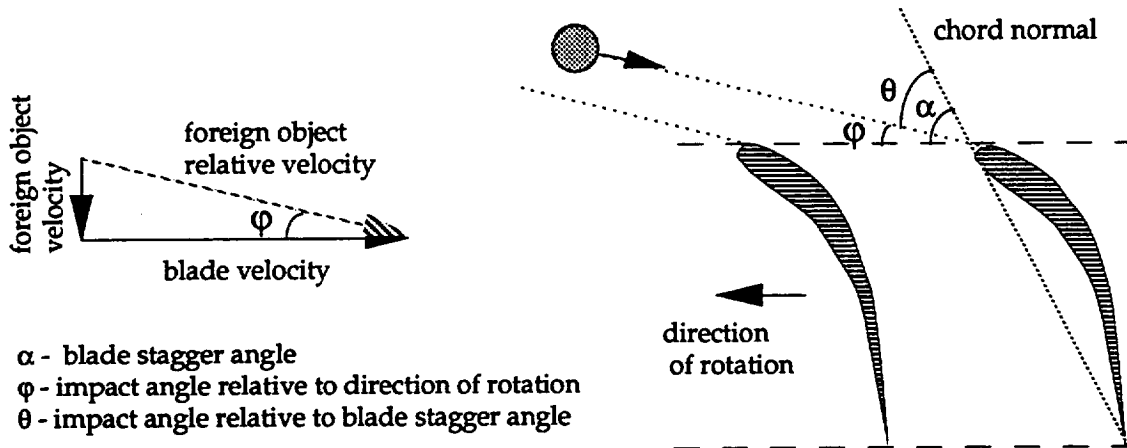

Figure 2.10. Geometry of Foreign Object Impact on the Blade

CARD B6b (Required If NRFOD > 0 and ICEPACT=1 on Card Bla)

Contents: Ice Impact Analysis

1	2	3	4	5	6	7
ALNGTH	AWIDTH	ATHICK	VP	RHO	TSTEP	BETA
10	20	30	40	50	60	70
0.700	0.700	0.700	100.00	0.000084	0.00001	0.0

<u>Field</u>	<u>Item</u>	<u>Format</u>	<u>Description</u>
1	ALNGTH	F	Length of ice block, inches.
2	AWIDTH	F	Width of ice block, inches.
3	ATHICK	F	Thickness of ice block, inches.
4	VP	F	Ice velocity, knots.
5	RHO	F	Ice density, lb.sec ² /in ⁴ .
6	TSTEP	F	Time step, in seconds, 1x10 ⁻⁰⁵ recommended
7	BETA	F	Modal damping, 0.0 is recommended.

Notes:

Although the input required for defining the ice size is in terms of length, width, and thickness, BLASIM computes an equivalent radius of the spherical ice, and calls the Foreign Object Damage (FOD) routines. A schematic of a spherical ice impacting on a blade is shown in Figure 2.10. The impact force is a function of the foreign object velocity as well as the blade velocity.

CARD B7 (Required If NRFOD > 0 on Card Bla)

Contents: Foreign Object Damage Input (continued)

1	2	3	4	5
FACT1	FACT2	NREF	NSTEP	NIMPACT
10	20	25	30	40
0.500	0.900	16	40	1

<u>Field</u>	<u>Item</u>	<u>Format</u>	<u>Description</u>
1	FACT1	F	Starting point along the span for impact modeling expressed as a fraction. (Figure 2.11)
2	FACT2	F	Ending point along the span for impact modeling expressed as a fraction. (Figure 2.11)
3	NREF	I	Leading edge impact node for local foreign object damage. Normally use 16. (Figure 2.11)
4	NSTEP	I	Number of timesteps required. 40 is suggested.
5	NIMPACT	I	Number of consecutive ice impacts desired with geometry update. The code provides output for pre-and-post ice impact conditions for the requested analyses.

Notes:

Figure 2.11 shows the local mesh used for ice impact analysis. The region between closest global stations to FACT1 and FACT2 will be subdivided into 7 equal stations with 35 nodes. The schematic of a typical re-meshed region is in Figure 2.11. If the impact node is 16, impact will take place approximately half way between FACT1 and FACT2. For example, if FACT1=0.5 and FACT2=0.9, the impact will be at the closest node to 0.7 (70%). It is important to note that the impact node is in the local system.

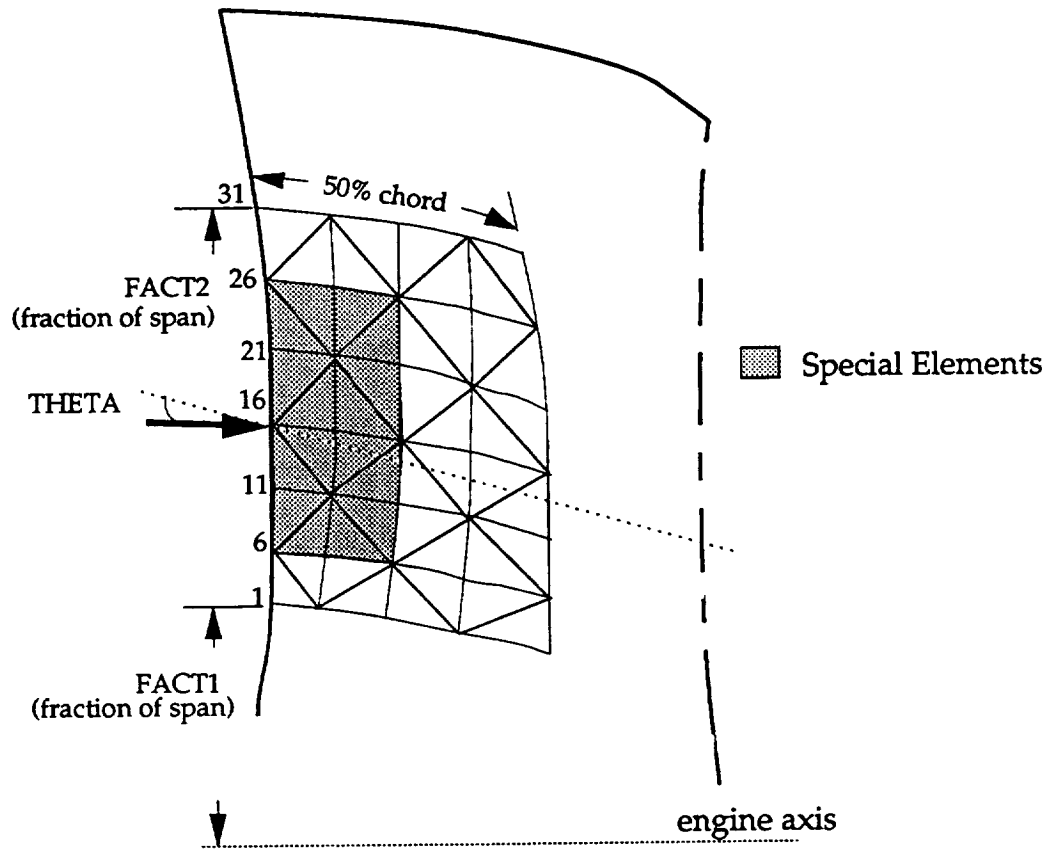

Figure 2.11. Local Foreign Object Damage Model

CARD B8a (Required Only If Composite Ply Properties are Input)

Contents: Material Properties (Input NMATRL Values)

1	2	3	4	5
E11(I)	E22(I)	V12(I)	G12(I)	RH(I)
10	20	30	40	50
0.165E8	0.165E8	0.300	0.634E7	0.00044

<u>Field</u>	<u>Item</u>	<u>Format</u>	<u>Description</u>
1	E11(I)	E	Youngs modulus in primary (1-1) direction, psi.
2	E22(I)	E	Youngs modulus in secondary (2-2) direction, psi.
3	V12(I)	F	Poissons ratio.
4	G12(I)	E	Shear modulus, psi.
5	RH(I)	F	Mass density, lb sec ² /in ⁴ .

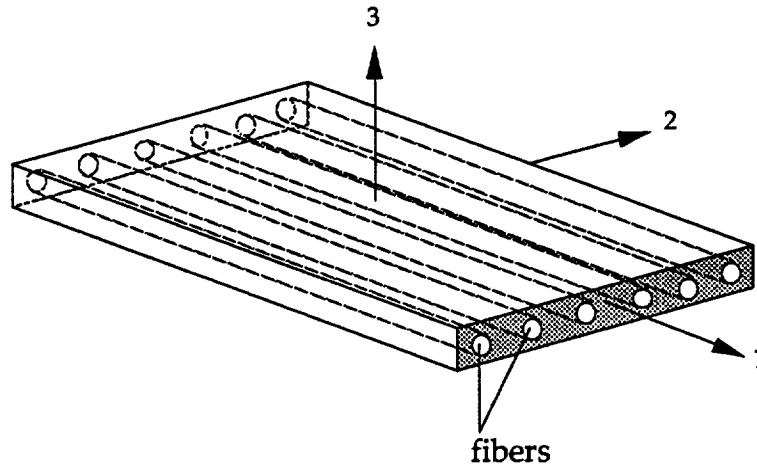

Figure 2.12. Unidirectionally Reinforced Lamina

CARD B8b (Required If NCD=3 and Fiber-Matrix Combinations are Input)

Contents: Specification of fiber/matrix combinations (Input NMATRL Values)

1	2	3	4	5	6	7	8
A1	FBR(I)	MTR(I)	FVR(I)	VD(I)	TU(I)	TC(I)	PMOIST(I)
7	14	18	26	34	42	50	58

MATCARD	T300	EPOC	0.4	0.0	70	70	1.0
---------	------	------	-----	-----	----	----	-----

<u>Field</u>	<u>Item</u>	<u>Format</u>	<u>Description</u>
1	A1	A7	Must Enter MATCARD.
2	FBR(I)	A4	Keyword for fiber, see list below.
3	MTR(I)	A4	Keyword for matrix, see list below.
4	FVR(I)	F	Fiber volume ratio.
5	VD(I)	F	Void volume ratio.
6	TU(I)	F	Use temperature.
7	TC(I)	F	Cure temperature.
8	PMOIST(I)	F	Percent moisture per weight.

Notes:

The ICAN code [3] uses a dedicated Data Bank containing properties for a large number of fibers and matrices. A complete listing of the Data Bank can be found in Section B.4 of Appendix B. Some of the popular fibers and matrices are listed below for user's convenience.

<i>Fiber Keyword</i>	<i>Description</i>	<i>Matrix Keyword</i>	<i>Description</i>
T300	Graphite	EPOC	Epoxy
P100	Graphite (High Modulus)	IMLS	Inter. Modulus Low Strength
HMSF	Surface Fiber (High Modulus)	IMHS	Inter. Modulus High Strength
SGLA	S-Glass	HMHS	High Modulus High Strength
EGLA	E-Glass	POLY	Polyimide
SW4M	Stainless Steel Wire	SSLA	Stainless Steel
TITF	Titanium	TIT6	Titanium
TUNG	Tungsten	FECR	Superalloy
SICA	Silicon Carbide on Alum.	ALTX	Aluminum
BOR5	Boron (5 Mil. Diameter)	BORM	Boron

CARD B9 (Required If NCD = 1 on Card Bla)

Contents: Data Associated With a Hollow Blade Design

1	2	3	4	5	6	7
DLE	DTE	DROOT	DDTIP	TTI	TLT	BTA
10	20	30	40	50	60	70
0.2500	0.500	3.00	7.00	0.0005	0.0005	0.00

<u>Field</u>	<u>Item</u>	<u>Format</u>	<u>Description</u>
1	DLE	F	Distance to hole from leading edge, inches.
2	DTE	F	Distance to hole from trailing edge, inches.
3	DROOT	F	Distance to hole from airfoil root, inches.
4	DTIP	F	Distance to hole from airfoil, tip, inches.
5	TTI	F	Thickness of skin, inches.
6	TLT	F	Thickness of inlay, inches.
7	BTA	F	Inlay fiber angle, degrees.

Notes:

Figure 2.13 shows the dimensions and layup associated with a hollow blade design. Two sets of material properties are required for the hollow blade: the first material defines the skin properties and the second defines the inlay properties. BLASIM treats the hollow section as a third material by defining a material of a very low modulus and high strength. If PREBLASIM is used to generate BLASIM input file, the material properties of a hollow blade are automatically written in the input file.

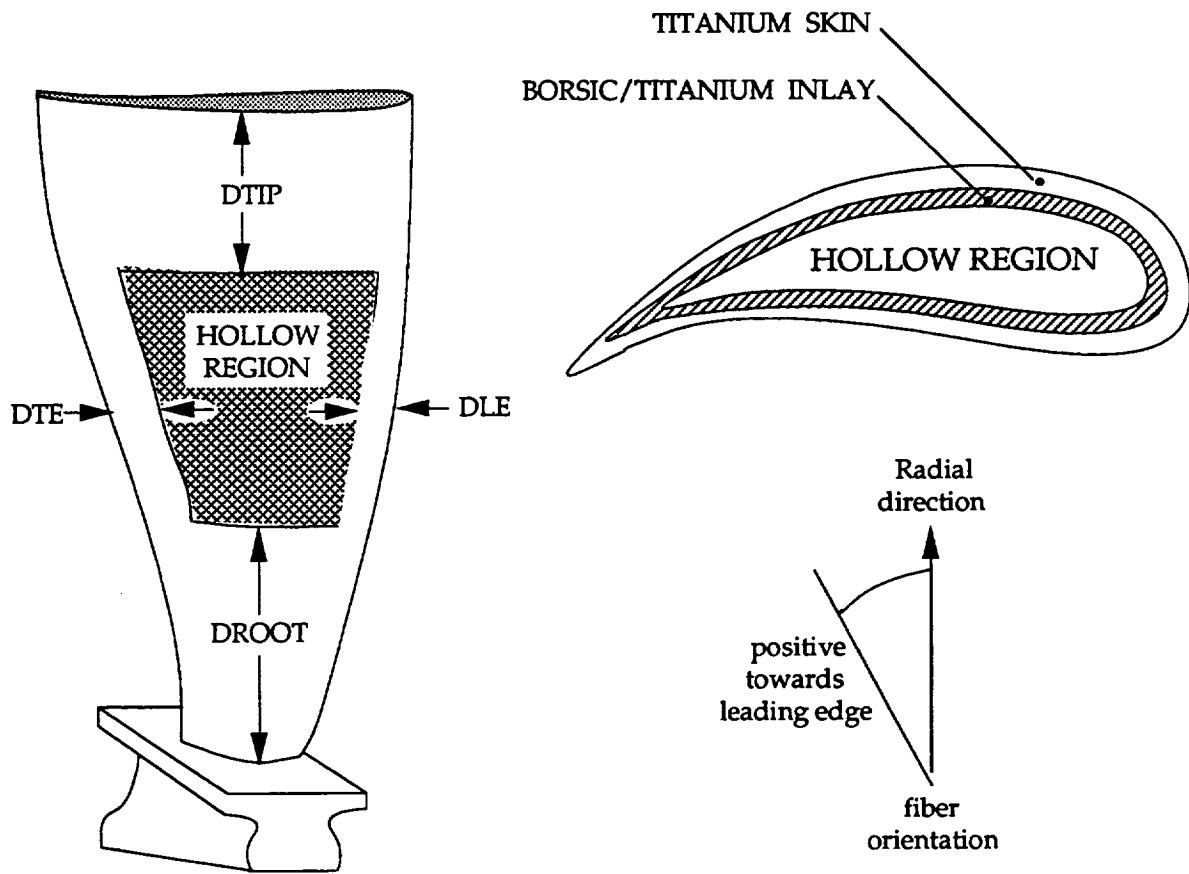

Figure 2.13. Dimensions and Layup Associated With a Hollow Blade Design

CARD B9a (Required If NCD = 2 on Card Bla)

Contents: Data Associated with a Superhybrid Blade Design.

1	2	3	4	5	6
TIS	TIC	PCBA	BAA	GEA	AMPA
10	20	30	40	50	60
0.005	0.005	50.0	0.0	0.0	0.0

<u>Field</u>	<u>Item</u>	<u>Format</u>	<u>Description</u>
1	TIS	F	Skin thickness, inches.
2	TIC	F	Center thickness, inches.
3	PCBA	F	Outer composite percent (remaining is inner composite).
4	BAA	F	Outer composite fiber angle, degrees.
5	GEA	F	Inner composite fiber angle, degrees.
6	AMPA	F	Added mass patch option. If AMPA = 0: No added mass. If AMPA > 0: Added mass option active, and AMPA reflects mass per inch ² , lb.sec ² /in ⁴ .

Notes:

Figure 2.14 shows the layup associated with a superhybrid blade design where four materials are required. If PREBLASIM is used to generate BLASIM input file, the material properties of a superhybrid blade are automatically written in the input file.

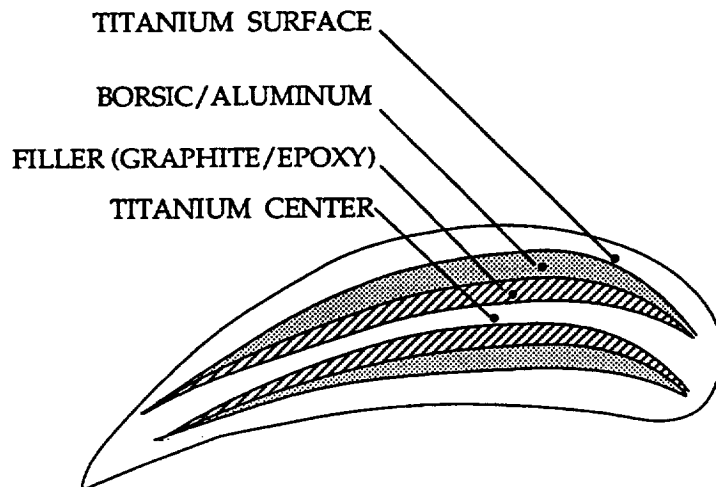

Figure 2.14. Layup Associated with a Superhybrid Blade Design

CARD B9b (Required If NCD = 3 on Card Bla)

Contents: Layer Thickness for Composite Blade Design.

1	2	3	4	5	6	7
THKDST(1)	THKDST(2)	THKDST(3)	THKDST(4)	THKDST(5)	THKDST(6)	THKDST(7)
8	16	24	32	40	48	56
0.005	0.005	0.005	0.005			

Field	Item	Format	Description
1-7	THKDST	F	Initial layer thickness, inches (Figure 2.15).

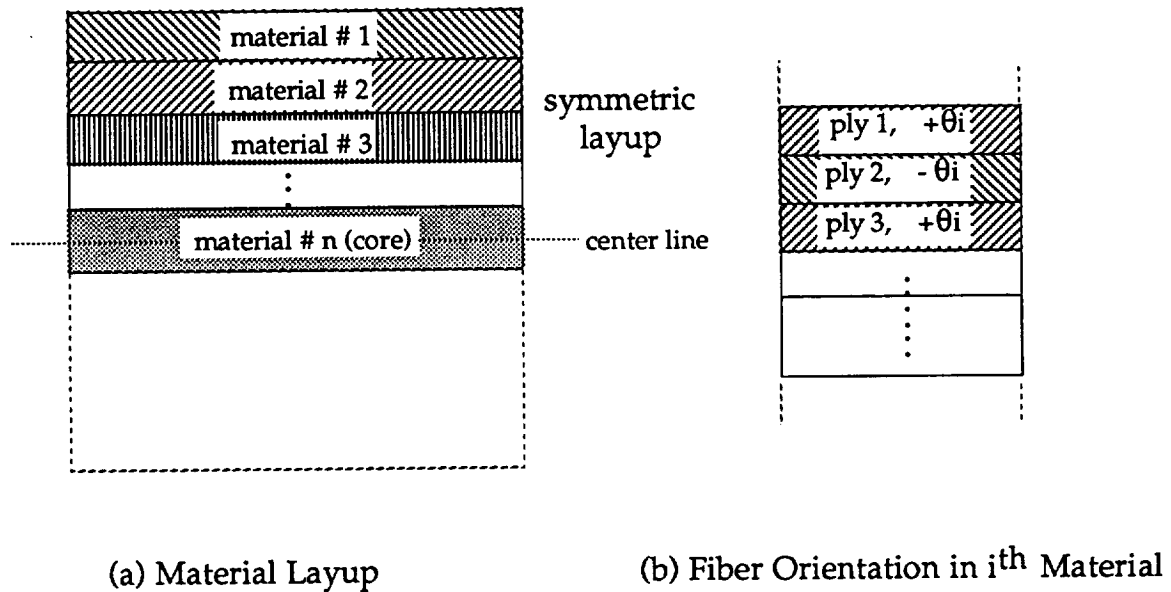

Figure 2.15. Layer Configuration of a Composite Blade

CARD B9c (Required If NCD = 3 on Card Bla)

Contents: Ply Angles for Composite Blade Design.

1	2	3	4	5	6	7
PLYDST(1)	PLYDST(2)	PLYDST(3)	PLYDST(4)	PLYDST(5)	PLYDST(6)	PLYDST(7)
8	16	24	32	40	48	56
0.000	45.0	-45.0	0.000			

<u>Field</u>	<u>Item</u>	<u>Format</u>	<u>Description</u>
1-7	PLYDST	F	First ply angles for I th composite material, degrees (Figure 2.15).

CARD B9d (Required If NCD = 3 on Card Bla)

Contents: Ply thickness for composite blade design.

1	2	3	4	5	6	7
THKLYR(1)	THKLYR(2)	THKLYR(3)	THKLYR(4)	THKLYR(5)	THKLYR(6)	THKLYR(7)
8	16	24	32	40	48	56
0.005	0.005	0.005	0.005			

<u>Field</u>	<u>Item</u>	<u>Format</u>	<u>Description</u>
1-7	THKLYR	F	Ply thickness of I th composite material, inches (Figure 2.15).

Notes:

(a) Material Layer Configuration

The program computes the number of plies of each material needed to make the layer thickness of material i equal THKDST (i) (Figure 2.15a).

1. In any given element, if the element total thickness can accommodate 1, 2, 3,...,n-1 materials to their specified maximum limit, the remaining thickness is assigned to the nth material (core).
2. If the total thickness can not accommodate all the material layers to their limit, plies are deleted from the material layers in the order (n-1), (n-2), ... 2. In otherwords, material 1 is always present and plies in (n-1)th material are deleted first.
3. If the element thickness is less than the twice the thickness of material 1 (skin), element thickness is adjusted to be equal to that value.

(b) Fiber Orientation

The layup is assumed symmetrical with angles *alternating* in sign starting from the specified value *within a material layer* (Figure 2.15b).

CARD B9e

Contents: Blade cross-section offsets.

1	2	3	4	5	6
ACLX	BCLX	CCLX	ACLY	BCLY	CCLY
8	16	24	32	40	48
0.000	0.000	0.000	0.000	0.000	0.000

<u>Field</u>	<u>Item</u>	<u>Format</u>	<u>Description</u>
1	ACLX	F	See below
2	BCLX	F	"
3	CCLX	F	"
4	ACLY	F	"
5	BCLY	F	"
6	CCLY	F	"

Notes:

Offsets of spanwise cross-sections from a straight line perpendicular to a straight line perpendicular to the engine axis are defined by:

$$x = ACLX * Z + BCLX * Z^2 + CCLX * Z^3$$

$$y = ACLY * Z + BCLY * Z^2 + CCLY * Z^3$$

where Z is a spanwise variable, y is chordwise, and x is transverse.

CARD B10 (Required If AMPA ≠ 0 on Card B9a)

Contents: Local Increased Density Input

1	2	3	4
ADLE	ADTE	ADROOT	ADTIP
10	20	30	40
0.250	0.500	3.00	7.00

<u>Field</u>	<u>Item</u>	<u>Format</u>	<u>Description</u>
1	ADLE	F	Distance to patch from leading edge, inches.
2	ADTE	F	Distance to patch from trailing edge, inches.
3	ADROOT	F	Distance to patch from blade root, inches.
4	ADTIP	F	Distance to patch from blade tip, inches.

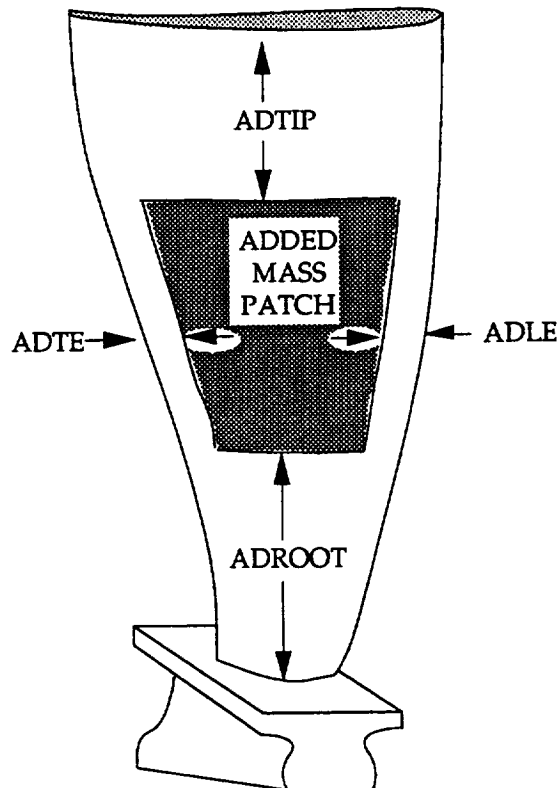

Figure 2.16. Dimensions Associated With a Local Increased Density Blade

CARD B11

Contents: Material Strength Limits. Input NMATRL Values.

1	2	3	4	5	6
X1T(I)	X1C(I)	X2T(I)	X2C(I)	S6P(I)	S6M(I)
10	20	30	40	50	60
7.4E05	7.4E05	7.4E05	7.4E05	4.4E04	4.4E04

<u>Field</u>	<u>Item</u>	<u>Format</u>	<u>Description</u>
1	X1T	E	Ultimate tensile strength in fiber direction, psi.
2	X1C	E	Ultimate compressive strength in fiber direction, psi.
3	X2T	E	Ultimate tensile strength perpendicular to fiber direction, psi.
4	X2C	E	Ultimate compressive strength perpendicular to fiber direction, psi.
5	S6P	E	Ultimate shear strength in x-y direction, psi.
6	S6M	E	Ultimate shear strength in y-x direction, psi.

Notes:

1. Input all strengths with positive value.
2. S6P and S6M are usually equal.

2.3.3 DATA BLOCK C: Boundary Condition Data

The boundary conditions and Guyan reduction data are defaulted in BLASIM. The degrees of freedom at the root of the blade are restrained. This block is included in BLASIM.INP if the user decides to modify the boundary conditions and Guyan reduction data.

CARD C1

Contents: Title

1
A
23
BOUNDARY CONDITION DATA

<u>Field</u>	<u>Item</u>	<u>Format</u>	<u>Description</u>
1	A	A23	must enter BOUNDARY CONDITION DATA

CARD C2

Contents: Boundary condition data

1	2	3	4	5	6	7	8	9	
A1	I1	A3	A4	I2	A5	I3	A6	I4	
8	16	24	32	40	48	56	64	72	
BCS SET		1	SUPPRESS	DOFS	123456	NODES	1	THRU	5

<u>Field</u>	<u>Item</u>	<u>Format</u>	<u>Description</u>
1	A1	A8	Boundary data mnemonic, see below.
2	I1	I8	Optional identification.
3-4	A3-A4	A16	Mnemonic, see below.
5	I2	I8	Suppressed degrees of freedom.
6	A5	A8	Mnemonic
7	I3	I8	Starting node to which boundary condition apply.
8	A6	A8	Mnemonic.
9	I4	I8	Final node to which boundary conditions apply.

Of the first mnemonic (BCS SET) , only the initial B is required.

CARD C3

Contents: Analysis set data indicator.

1
A
32
ASET DATA (GUYAN REDUCTION)

<u>Field</u>	<u>Item</u>	<u>Format</u>	<u>Description</u>
1	A	A32	Item indicates beginning of analysis set (ASET) data. The first character must be A. Suggestion: ASET DATA (Guyan Reduction).

CARD C4

Contents: Analysis Set Data

1	2	3	4	5	6	7	8	9	10
A1	A2	I1	A3	I2	I3	I4	I5	I6	I7
8	16	24	32	40	48	56	64	72	80
ANALYZE	DOFS	2	NODES	21	23	25	31	33	35

<u>Field</u>	<u>Item</u>	<u>Format</u>	<u>Description</u>
1-2	A1-A2	A16	Mnemonic
3	I1	I8	Analyzed degree of freedom at nodes.
4	A3	A8	Mnemonic
5-10	I2-I7	6I8	Nodes at which degrees of freedom in field 3 are analyzed

Input two C4 cards. Each analysis set must contain six nodes. The total number of analysis degrees of freedom must equal 24. All mnemonics are optional.

2.3.4 DATA BLOCK D: Pressure Data

This block is to be included in *BLASIM.INP* if the pressure load is applied.

CARD D1

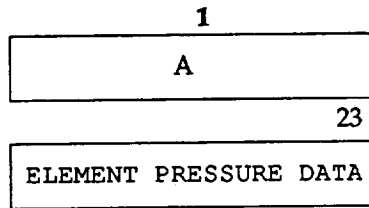

<u>Field</u>	<u>Item</u>	<u>Format</u>	<u>Description</u>
1	A	A21	must enter ELEMENT PRESSURE DATA

CARD D2

1	2	3
A1	A2	PR
8	16	24
PRESSURE	1	5.0

<u>Field</u>	<u>Item</u>	<u>Format</u>	<u>Description</u>
1	A1-A2	A16	Any 16 character mnemonic
2	PR	F8	Net pressure on element

Enter one D2 card per element (total of 80). Fields A1-A2 may be used to identify card type and element number

2.3.5 DATA BLOCK E: Fatigue Life Data (Goodman Diagram)

This block is to be included in *BLASIM.INP* if fatigue life analysis is desired.

CARD E1

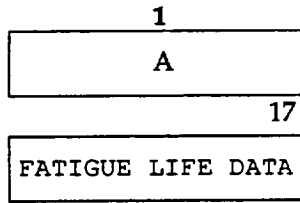

<u>Field</u>	<u>Item</u>	<u>Format</u>	<u>Description</u>
1	A	A32	must enter FATIGUE LIFE DATA

CARD E2

A	STL
16	24
STATIC	130000.

<u>Field</u>	<u>Item</u>	<u>Format</u>	<u>Description</u>
1	A	A8	Any 8 character mnemonic
2	STL	F8	Static limit

CARD E3

1	2
A	DNL
16	24
DYNAMIC	130000

<u>Field</u>	<u>Item</u>	<u>Format</u>	<u>Description</u>
1	A	A8	Any 8 character mnemonic
2	DNL	F8	Dynamic Limit

CARD E4

1	2
A	MULT
16	24
MULTIPLE	0.000

<u>Field</u>	<u>Item</u>	<u>Format</u>	<u>Description</u>
1	A	A8	Any 8 character mnemonic
2	MULT	F8	Multiple of static pressure used to compute forcing function

CARD E5

1	2
A	TMLT
16	24
TMELT	2000.0

<u>Field</u>	<u>Item</u>	<u>Format</u>	<u>Description</u>
1	A	A8	Any 8 character mnemonic
2	TMLT	F8	Melting Temperature

CARD E6

1	2
A	TREF
8	16
TREF	100.0

<u>Field</u>	<u>Item</u>	<u>Format</u>	<u>Description</u>
1	A	A8	Any 8 character mnemonic
2	TREF	F8	Reference Temperature

CARD E7

1	2
A	TR
8	16
TROOT	100.0

<u>Field</u>	<u>Item</u>	<u>Format</u>	<u>Description</u>
1	A	A8	Any 8 character mnemonic
2	TR	F8	Root (current) Temperature

CARD E8

1	2
A	EXP
8	16

EXP	1.0
-----	-----

<u>Field</u>	<u>Item</u>	<u>Format</u>	<u>Description</u>
1	A	A8	Any 8 character mnemonic
2	EXP	F8	Exponent

CARD E9

1	2
A	FRCFN
8	16
FRCFN	2.0

<u>Field</u>	<u>Item</u>	<u>Format</u>	<u>Description</u>
1	A	A8	Any 8 character mnemonic
2	FRCFN	F8	Forcing function factor

SECTION 3.0

VALIDATION TEST CASES

Four validation test cases for the static and modal analyses capabilities of BLASIM are included in this section. The results from static analysis are compared to MSC/NASTRAN [5] while the results from modal analysis are compared to MSC/NASTRAN, MARC [6], and MHOST [7].

3.1 SR3 Propfan Blade Under Centrifugal Loading

In this test case, a propfan blade made of aluminum material is subjected to centrifugal loading of 2000 rpm. Figure 3.1 shows the geometry and finite element grid of the SR3 propfan blade used. The blade has a uniform thickness of 0.2 inches.

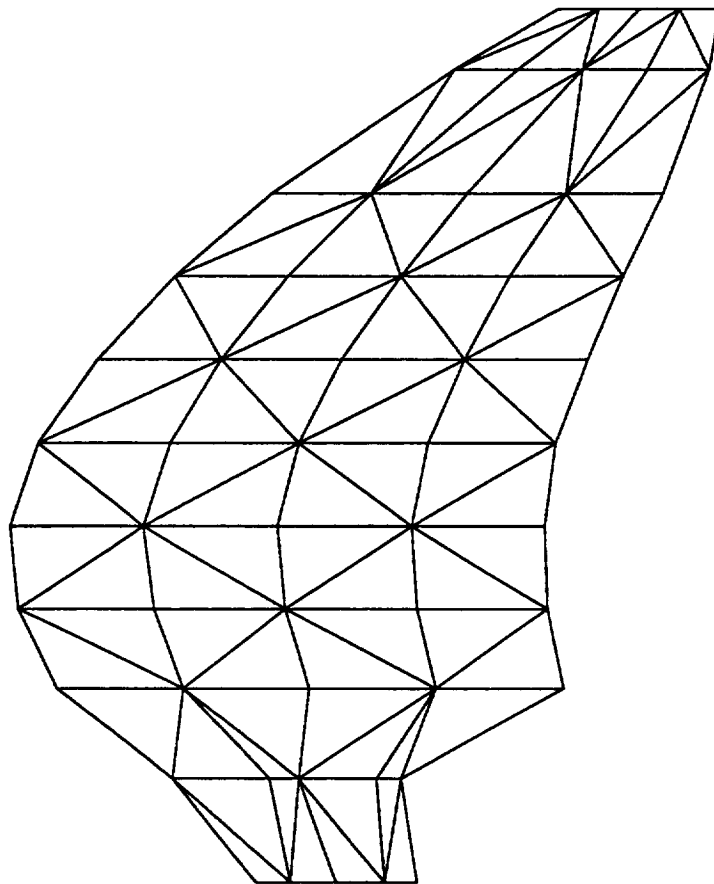

Figure 3.1. Geometry and Finite Element Mesh of the SR3 Propfan Blade

```

0.0 0.200 0.000 0.0
8.0
5 0 0 0 1 0 0 0 0 1.98764 1
1.0001.0001.0001.0001.0001.000
2 0.2000 5 0.2000 7 0.2000 9 0.200011 0.2000
2500.000 1500.000 5 1 2 3 4 5
0.100E+08 0.100E+08 0.30000 0.385E+07 0.00025
0.0000 0.0000 0.0000 0.0000 0.0000 0.0000
0.400E+05 0.400E+05 0.400E+05 0.400E+05 0.220E+05 0.220E+05

```

```

CARD A9
CARD A10
CARD B1a
CARD B1b
CARD B2
CARD B5
CARD B8
CARD B9e
CARD B11

```

The case discussed here was also solved using MSC/NASTRAN. The results from both programs, BLASIM and MSC/NASTRAN are in very good agreement. Figure 3.2(a,b) shows a comparison plots of the displacement and stress results.

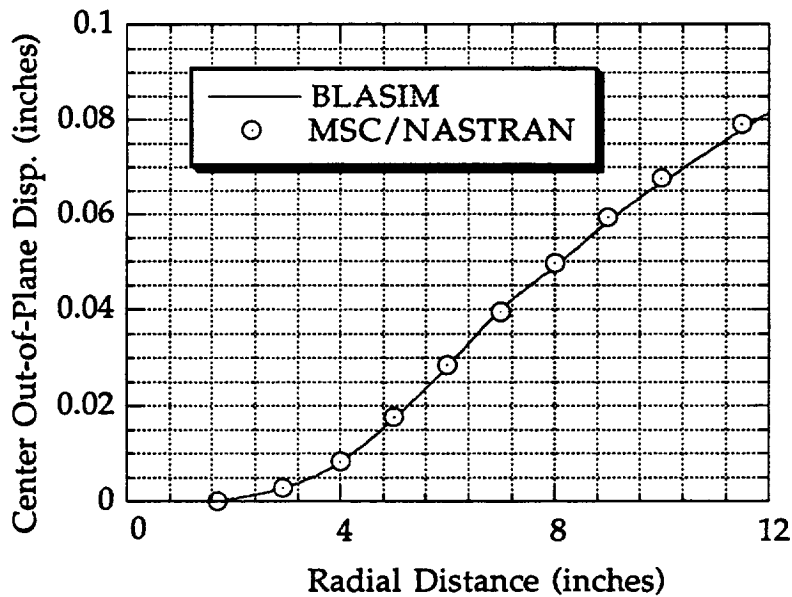

Figure 3.2a. Displacements Comparison of BLASIM and MSC/NASTRAN Results (Static Analysis - Centrifugal Loading)

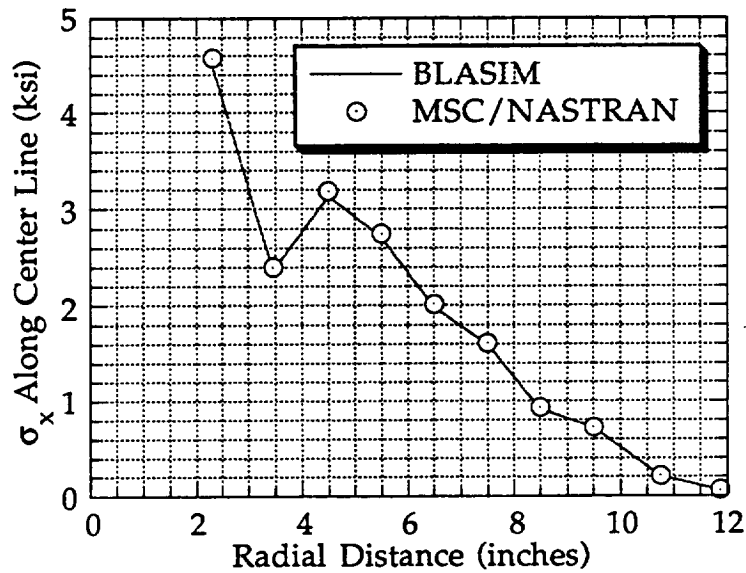

Figure 3.2b. Stress Comparison of BLASIM and MSC/NASTRAN Results (Static Analysis - Centrifugal Loading)

3.2 SR3 Propfan Blade Under Uniform Pressure Loading

The same propfan blade is used in this case with a uniform pressure of 1 psi applied on all elements. The input file to the BLASIM code is listed below:

```

sr3 swept propfan aluminum blade , pressure load only
NASTRAN GEOMETRY TYPE                                CARD A2
1.0                                                    CARD A3
5.0 1.0                                              CARD A4
2.0
1
GRID      1      1.7000  0.0427 -0.6987  0.2000    CARD A6a
GRID      2      1.7000  0.0244 -0.3992  0.2000    CARD A6a
GRID      3      1.7000  0.0000  0.0000  0.2000    CARD A6a
GRID      4      1.7000 -0.0244  0.3992  0.2000    CARD A6a
GRID      5      1.7000 -0.0427  0.6987  0.2000    CARD A6a
GRID      6      2.9300 -0.1929 -1.4174  0.2000    CARD A6a
GRID      7      2.9300 -0.1015 -0.5853  0.2000    CARD A6a
GRID      8      2.9300 -0.0724 -0.3390  0.2000    CARD A6a
GRID      9      2.9300  0.0087  0.3512  0.2000    CARD A6a
GRID     10      2.9300  0.0291  0.5578  0.2000    CARD A6a
GRID     11      4.0000 -0.6293 -2.4260  0.2000    CARD A6a
GRID     12      4.0000 -0.3548 -1.3261  0.2000    CARD A6a
GRID     13      4.0000 -0.1202 -0.2297  0.2000    CARD A6a
GRID     14      4.0000  0.0895  0.8650  0.2000    CARD A6a
GRID     15      4.0000  0.2999  1.9609  0.2000    CARD A6a
GRID     16      5.0000 -0.9226 -2.7414  0.2000    CARD A6a
GRID     17      5.0000 -0.5450 -1.5921  0.2000    CARD A6a
GRID     18      5.0000 -0.2151 -0.4479  0.2000    CARD A6a
GRID     19      5.0000  0.0718  0.6946  0.2000    CARD A6a
GRID     20      5.0000  0.3207  1.8349  0.2000    CARD A6a
GRID     21      6.0000 -1.1175 -2.8284  0.2000    CARD A6a
GRID     22      6.0000 -0.6586 -1.6652  0.2000    CARD A6a
GRID     23      6.0000 -0.2516 -0.5063  0.2000    CARD A6a
GRID     24      6.0000  0.1137  0.6491  0.2000    CARD A6a

```

GRID	25	6.0000	0.4278	1.8035	0.2000	CARD A6a						
GRID	26	7.0000	-1.1571	-2.5743	0.2000	CARD A6a						
GRID	27	7.0000	-0.6398	-1.4487	0.2000	CARD A6a						
GRID	28	7.0000	-0.1763	-0.3284	0.2000	CARD A6a						
GRID	29	7.0000	0.2503	0.7908	0.2000	CARD A6a						
GRID	30	7.0000	0.6269	1.9067	0.2000	CARD A6a						
GRID	31	8.0000	-1.0395	-2.0722	0.2000	CARD A6a						
GRID	32	8.0000	-0.4805	-1.0092	0.2000	CARD A6a						
GRID	33	8.0000	0.0260	0.0507	0.2000	CARD A6a						
GRID	34	8.0000	0.4973	1.1084	0.2000	CARD A6a						
GRID	35	8.0000	0.9197	2.1632	0.2000	CARD A6a						
GRID	36	9.0000	-0.7514	-1.3955	0.2000	CARD A6a						
GRID	37	9.0000	-0.1736	-0.4223	0.2000	CARD A6a						
GRID	38	9.0000	0.3542	0.5477	0.2000	CARD A6a						
GRID	39	9.0000	0.8482	1.5146	0.2000	CARD A6a						
GRID	40	9.0000	1.2962	2.4797	0.2000	CARD A6a						
GRID	41	10.0000	-0.2627	-0.5530	0.2000	CARD A6a						
GRID	42	10.0000	0.3006	0.2949	0.2000	CARD A6a						
GRID	43	10.0000	0.8169	1.1409	0.2000	CARD A6a						
GRID	44	10.0000	1.3065	1.9844	0.2000	CARD A6a						
GRID	45	10.0000	1.7529	2.8262	0.2000	CARD A6a						
GRID	46	11.5000	0.9192	1.0088	0.2000	CARD A6a						
GRID	47	11.5000	1.3469	1.5671	0.2000	CARD A6a						
GRID	48	11.5000	1.7427	2.1232	0.2000	CARD A6a						
GRID	49	11.5000	2.1224	2.6784	0.2000	CARD A6a						
GRID	50	11.5000	2.4765	3.2322	0.2000	CARD A6a						
GRID	51	12.2500	1.7253	1.9169	0.2000	CARD A6a						
GRID	52	12.2500	2.0074	2.2667	0.2000	CARD A6a						
GRID	53	12.2500	2.2727	2.6154	0.2000	CARD A6a						
GRID	54	12.2500	2.5290	2.9628	0.2000	CARD A6a						
GRID	55	12.2500	2.7682	3.3100	0.2000	CARD A6a						
	0.0	0.200	0.000	0.0		CARD A9						
				8.0		CARD A10						
	5	0	0	0	1	0	0	0	0	1.98764	1	CARD B1a
	1.0001	0.0001	0.0001	0.0001	0.0001	0.0001	0.0001	0.0001	0.0001			CARD B1b
	2	0.2000	5	0.2000	7	0.2000	9	0.2000	11	0.2000		CARD B2
	2500.000	1500.000	5	1	2	3	4	5				CARD B5
	0.100E+08	0.100E+08	0.30000	0.385E+07	0.00025							CARD B8
	0.0000	0.0000	0.0000	0.0000	0.0000	0.0000						CARD B9e
	0.400E+05	0.400E+05	0.400E+05	0.400E+05	0.220E+05	0.220E+05						CARD B11

ELEMENT PRESSURE DATA

PRESSURE	1	-1.0
PRESSURE	2	-1.0
PRESSURE	3	-1.0
PRESSURE	4	-1.0
PRESSURE	5	-1.0
PRESSURE	6	-1.0
PRESSURE	7	-1.0
PRESSURE	8	-1.0
PRESSURE	9	-1.0
PRESSURE	10	-1.0
PRESSURE	11	-1.0
PRESSURE	12	-1.0
PRESSURE	13	-1.0
PRESSURE	14	-1.0
PRESSURE	15	-1.0
PRESSURE	16	-1.0
PRESSURE	17	-1.0
PRESSURE	18	-1.0
PRESSURE	19	-1.0

PRESSURE	20	-1.0
PRESSURE	21	-1.0
PRESSURE	22	-1.0
PRESSURE	23	-1.0
PRESSURE	24	-1.0
PRESSURE	25	-1.0
PRESSURE	26	-1.0
PRESSURE	27	-1.0
PRESSURE	28	-1.0
PRESSURE	29	-1.0
PRESSURE	30	-1.0
PRESSURE	31	-1.0
PRESSURE	32	-1.0
PRESSURE	33	-1.0
PRESSURE	34	-1.0
PRESSURE	35	-1.0
PRESSURE	36	-1.0
PRESSURE	37	-1.0
PRESSURE	38	-1.0
PRESSURE	39	-1.0
PRESSURE	40	-1.0
PRESSURE	41	-1.0
PRESSURE	42	-1.0
PRESSURE	43	-1.0
PRESSURE	44	-1.0
PRESSURE	45	-1.0
PRESSURE	46	-1.0
PRESSURE	47	-1.0
PRESSURE	48	-1.0
PRESSURE	49	-1.0
PRESSURE	50	-1.0
PRESSURE	51	-1.0
PRESSURE	52	-1.0
PRESSURE	53	-1.0
PRESSURE	54	-1.0
PRESSURE	55	-1.0
PRESSURE	56	-1.0
PRESSURE	57	-1.0
PRESSURE	58	-1.0
PRESSURE	59	-1.0
PRESSURE	60	-1.0
PRESSURE	61	-1.0
PRESSURE	62	-1.0
PRESSURE	63	-1.0
PRESSURE	64	-1.0
PRESSURE	65	-1.0
PRESSURE	66	-1.0
PRESSURE	67	-1.0
PRESSURE	68	-1.0
PRESSURE	69	-1.0
PRESSURE	70	-1.0
PRESSURE	71	-1.0
PRESSURE	72	-1.0
PRESSURE	73	-1.0

PRESSURE	74	-1.0
PRESSURE	75	-1.0
PRESSURE	76	-1.0
PRESSURE	77	-1.0
PRESSURE	78	-1.0
PRESSURE	79	-1.0
PRESSURE	80	-1.0

Figure 3.3 (a,b) shows the comparison plots of the displacement and stress results.

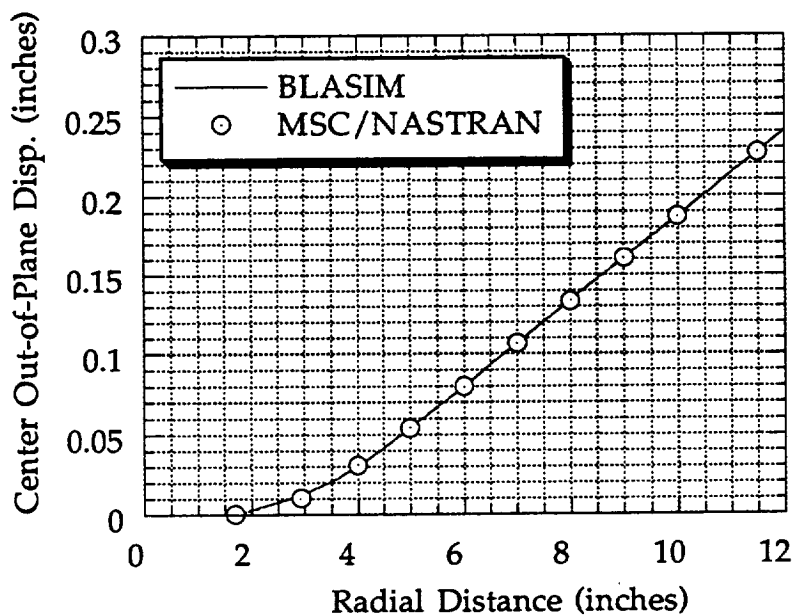

Figure 3.3a. Displacement Comparison of BLASIM and MSC/NASTRAN Results (Static Analysis - Pressure Loading)

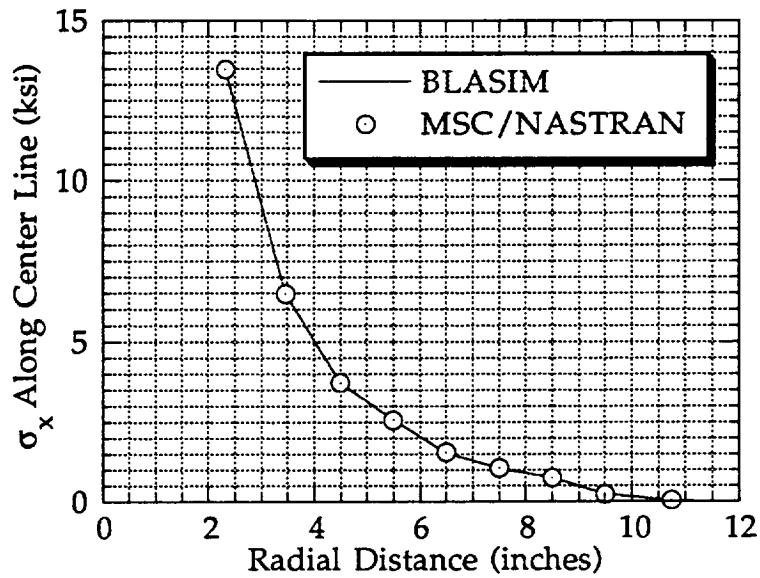

Figure 3.3b. Stress Comparison of BLASIM and MSC/NASTRAN Results (Static Analysis - Pressure Loading)

3.3 SR2 Propfan Blade Under Centrifugal Loading

An SR2 composite propfan blade (Figure 3.4) constructed with [0,±45,0] Titanium/Graphite-Epoxy/Titanium and subjected to a centrifugal load of 3000 rpm is analyzed using BLASIM and MSC/NASTRAN.

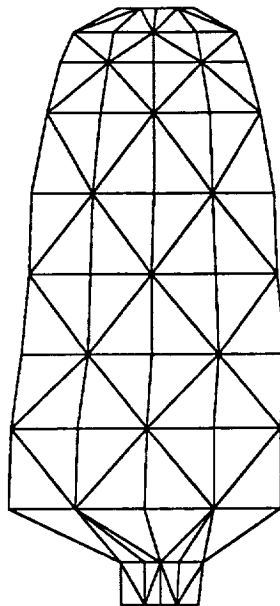

Figure 3.4. Finite Element Mesh of the SR2 Composite Propfan Blade

.0001.0001.0001.0001.0001.000												CARD B1b
2 0.8927 5 0.1447 7 0.0837 9 0.057611 0.0336												CARD B2
3200.000 2800.000 3 1 2 3												CARD B5
16.5E06 16.5E06 0.3000 6.40E06 .000440												CARD B8
32.0E06 1.0E+06 0.2500 0.70E06 .000150												CARD B8
32.0E06 1.0E+06 0.2500 0.70E06 .000150												CARD B8
16.5E06 16.5E06 0.3000 6.40E06 .000440												CARD B8
0.005 0.005 0.005 0.005												CARD B9b
0.000 +45.0 -45.0 0.000												CARD B9c
0.005 0.005 0.005 0.005												CARD B9d
0.000 0.000 0.000 0.000 0.000 0.000												CARD B9e
7.40E4 7.40E4 7.40E4 7.40E4 4.40E4 4.40E4												CARD B11
17.50E4 17.5E04 5.0E03 5.0E03 10.0E3 10.0E3												CARD B11
17.50E4 17.5E04 5.0E03 5.0E03 10.0E3 10.0E3												CARD B11
7.40E4 7.40E4 7.40E4 7.40E4 4.40E4 4.40E4												CARD B11

The displacements obtained from BLASIM are compared to those provided by MSC/NASTRAN. The displacement results show very good agreement and are presented in Figure 3.5.

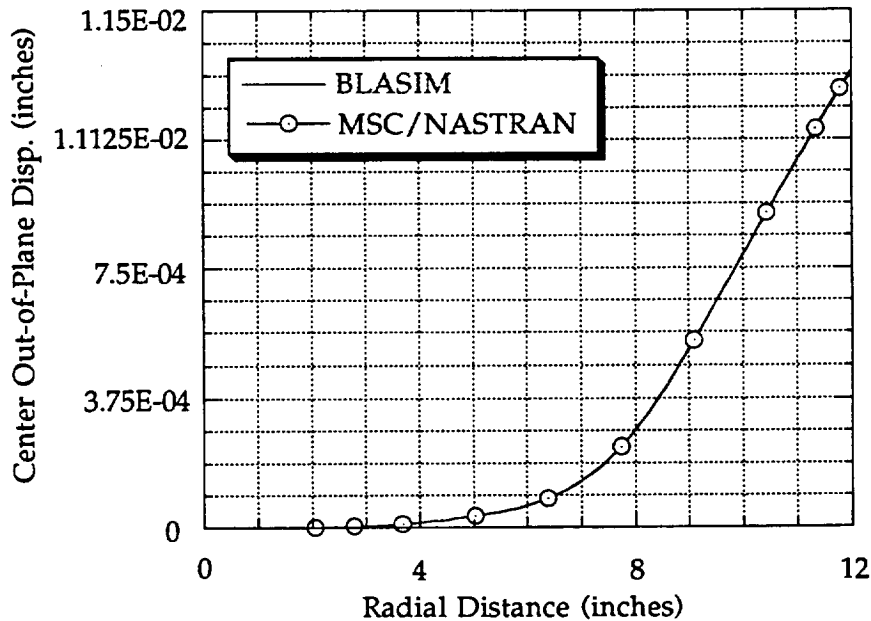

Figure 3.5. Displacements Comparison of BLASIM and MSC/NASTRAN Results (Static Analysis - Centrifugal Loading)

The stresses at the root of the blade obtained from BLASIM and MSC/NASTRAN are presented in the following table:

Source	Root Stress (psi)
BLASIM	883.93
MSC/NASTRAN	884.20

3.4 Free Vibration Analysis of an SR3 Propfan Blade

A free vibration analysis was conducted on the propfan blade used in Sections 3.1 and 3.2 to extract the first three natural frequencies. The results are compared to the solution provided by MSC/NASTRAN, MARC and MHOST. The BLASIM natural frequencies (cycles/sec) are in very good agreement with the ones from other finite element programs. A summary of the results is given:

Mode #	BLASIM	MSC/NASTRAN	MARC	MHOST
1	52.30	51.89	51.00	49.58
2	228.74	226.95	251.57	206.10
3	403.52	400.35	447.20	402.80

Notes:

The discrepancies for the second and third modes in the above table are due to the following:

1. BLASIM and MSC/NASTRAN use lumped mass method.
2. MARC and MHOST use consistent mass method.
3. BLASIM, MSC/NASTRAN, and MARC models consisted of 80 triangular elements while the MHOST model consisted of 40 quadrilateral elements.

SECTION 4.0

REFERENCES

1. MacNeal, R. H.: A Simple Quadrilateral Shell Element. *Computers and Structures*, vol. 8, Pergamon Press, Great Britain, 1978, pp. 175-183.
2. Brown, K.: Structural Tailoring of Engine Blades (STAEBL), Theoretical Manual, NASA Contractor Report CR-175112.
3. Murthy, P. L. N.; and Chamis, C. C.: Integrated Composite Analyzer (ICAN), Users and Programmers Manual. NASA TP2515, 1986.
4. Abbott, I. H. and Von Doenhoff, A. E.: *Theory of Wing Sections*. Dover Publications, Inc., New York, 1959, page 113.
5. MSC/NASTRAN, Version 65C, User's Manual. The MacNeal-Schwendler Corporation, 1987.
6. MARC, User Information Manual, MARC Analysis Corporation, 1988.
7. The MHOST Finite Element Program, Volume II-User's Manual, NASA CR-182235, 1989.

APPENDIX A

ICE IMPACT ANALYSIS OF SR-2 BLADE

A.1 Problem Description

The SR-2 unswept titanium propfan blade under centrifugal load of 4000 rpm and uniform pressure of 5 psi is considered for analysis using BLASIM. Static, modal, ice impact, flutter, and fatigue analyses capabilities are demonstrated in this problem. The blade is subject to a single ice impact at approximately 70% of the span. The ice speed is 100 knots and its dimensions are 0.7"x0.7"x0.7". Flutter analysis is conducted at a Mach number of 1.1 with a temperature of 32 F and a pressure of one atmosphere. The fatigue analysis input parameters selected for this case include static and dynamic stress limits of 75000 and 30000 psi, respectively, with a forcing function of 1.0.

In the input file, the geometry is defined using the finite element grid. A schematic of the planform of the blade with finite element grid is shown in the Figure A.1. The listing of the complete input is given in the next section.

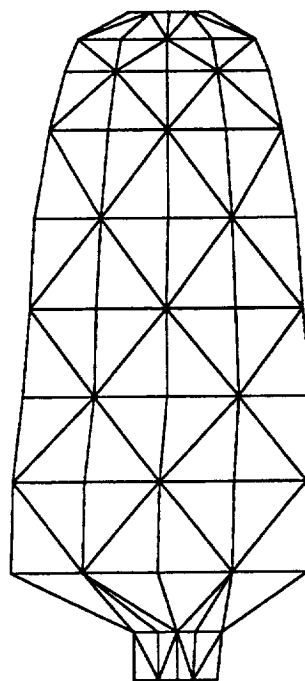

Figure A.1 Planform of the SR-2 Unswept Blade with Finite Element Grid

A.2 Input File

The interactive input generator PREBLASIM is used to create the input file to BLASIM, BLASIM.INP. Since the finite element grid option is used, a file named GRID.DAT containing the grid coordinates and thicknesses is prepared.

A listing of GRID.DAT is given below:

GRID	1	2.0600	0.0000	-0.4710	0.7267
GRID	2	2.0600	0.0000	-0.1980	1.0125
GRID	3	2.0600	0.0000	0.0000	1.0857
GRID	4	2.0600	0.0000	0.1980	1.0125
GRID	5	2.0600	0.0000	0.4710	0.7267
GRID	6	2.7780	0.0650	-0.5500	0.6666
GRID	7	2.7780	0.0510	-0.2190	0.7926
GRID	8	2.7780	0.0240	-0.0200	0.8927
GRID	9	2.7780	-0.0030	0.1980	0.8587
GRID	10	2.7780	0.0000	0.4710	0.7465
GRID	11	3.6840	0.4940	-1.5130	0.0990
GRID	12	3.6840	0.2030	-0.6550	0.2737
GRID	13	3.6840	-0.0540	0.1990	0.3339
GRID	14	3.6840	-0.2780	1.0540	0.2339
GRID	15	3.6840	-0.4710	1.9120	0.0774
GRID	16	5.0360	0.6530	-1.5240	0.0688
GRID	17	5.0360	0.2770	-0.6760	0.1804
GRID	18	5.0360	-0.0700	0.1680	0.2059
GRID	19	5.0360	-0.3900	1.0150	0.1343
GRID	20	5.0360	-0.6840	1.8630	0.0356
GRID	21	6.3890	0.7950	-1.5640	0.0486
GRID	22	6.3890	0.3580	-0.7400	0.1198
GRID	23	6.3890	-0.0450	0.0810	0.1447
GRID	24	6.3890	-0.4260	0.9020	0.1122
GRID	25	6.3890	-0.7760	1.7250	0.0340
GRID	26	7.7420	0.8840	-1.4970	0.0362
GRID	27	7.7420	0.4030	-0.7110	0.0891
GRID	28	7.7420	-0.0490	0.0750	0.1064
GRID	29	7.7420	-0.4800	0.8600	0.0835
GRID	30	7.7420	-0.8830	1.6460	0.0260
GRID	31	9.0940	0.9510	-1.4200	0.0285
GRID	32	9.0940	0.4400	-0.6750	0.0702
GRID	33	9.0940	-0.0500	0.0680	0.0837
GRID	34	9.0940	-0.5250	0.8120	0.0651
GRID	35	9.0940	-0.9780	1.5560	0.0207
GRID	36	10.4470	0.9680	-1.2870	0.0233
GRID	37	10.4470	0.4570	-0.6140	0.0575
GRID	38	10.4470	-0.0450	0.0570	0.0684
GRID	39	10.4470	-0.5400	0.7290	0.0533
GRID	40	10.4470	-1.0260	1.4020	0.0173
GRID	41	11.3480	0.8950	-1.1220	0.0193
GRID	42	11.3480	0.4270	-0.5380	0.0484
GRID	43	11.3480	-0.0370	0.0450	0.0576
GRID	44	11.3480	-0.4980	0.6290	0.0449
GRID	45	11.3480	-0.9550	1.2130	0.0148
GRID	46	11.7990	0.8050	-0.9800	0.0137
GRID	47	11.7990	0.3860	-0.4710	0.0366
GRID	48	11.7990	-0.0310	0.0370	0.0435
GRID	49	11.7990	-0.4460	0.5450	0.0341
GRID	50	11.7990	-0.8600	1.0540	0.0107
GRID	51	12.2500	0.3810	-0.4520	0.0082
GRID	52	12.2500	0.1830	-0.2180	0.0283

```

GRID      53      12.2500 -0.0140  0.0170  0.0336
GRID      54      12.2500 -0.2110  0.2510  0.0265
GRID      55      12.2500 -0.4080  0.4850  0.0066

```

Instructions for using PREBLASIM are given in section 2.1 of this manual. The interactive session as displayed on a computer screen when running PREBLASIM is listed below:

9-18-1992

09:22:07

```

BBBBBBB LL      AAAAAA  SSSSSS  IIIIIIII MM  MM
BB  BB LL      AA  AA  SS      II  MM MM MM
BB  BB LL      AA  AA  SS      II  MM MM MM
BBBBBBB LL      AAAAAAAA SSSSSS  II  MM MM MM
BB  BB LL      AA  AA      SS  II  MM  MM
BB  BB LL      AA  AA      SS  II  MM  MM
BBBBBBB LLLLLLLL AA  AA  SSSSSS  IIIIIIII MM  MM

```

Preprocessor for
BLades ASsessment for ice IMPact

This Module Will Automatically Generate Input File for BLASIM Program. The Blade Geometry May be Defined in One of the Following Forms: a) Provide the Blade Finite Element Nodal Coordinates and their Thicknesses Thru a File, b) Supply the Airfoil Coordinates Thru a File, c) Select one of the Built-in NACA Airfoils. Any Wrong Entries or Defaulted Data May be Changed by Editing the Input File Created by the Program. To Find the Data Card Number, Variable Name and its Description, See Appendix A of the BLASIM User's Manual.

....hit return to continue....

Summary of the Information Needed to Run the BLASIM Interactive Program is Given Here:

Description of Entry	CARD #
1. Definition of Blade Geometry, Choices are:	
a. Finite element coordinates & Thicknesses	A6a
b. Airfoil Coordinates & Stagger Angles	A6,A7,A8
c. Construction of Blade With Built-in Airfoil Models	None
2. Number of Blades & Operating Speed	A10,A3
3. Blade Root Angle & Thickness, Broach Angle	A9
4. Option for Local & Root Ice Impact Analysis	B1a,B6b
5. Option for Flutter Analysis	B1a,B3,B4
6. Option for Forcing Function Calculation	B1a
7. Redline & Minimum Cruise Speeds	B5
8. Number of Excitation Orders & Order Number	B5
9. Blade Type & Elastic Material Properties	B1a,B8,B11
10. Pressure Data (Optional)	D2
11. Fatigue Life Data (Optional)	E

....hit return to continue....

Enter Title of the Problem :
SR2 Unswept Titanium Blade

The Terms in Bold are User's Entries

Blade Description and Analyses Options

This is the First Section of the Input File. The Blade Geometry Speed, and Analyses Options are Defined Here. The User is Expected to Provide the Blade Finite Element Nodal or Airfoil Coordinates Thru a Data File or Select an Airfoil Model to Construct the Blade. See the User's Manual For More Details.

Airfoil or Finite Element Input (A/F)? :**F**
Enter format of the Grid coord. (x,y,z & thickness):**24x,4f8.4**
Enter Geometry Filename :**grid.dat**
Enter Number of Blades, and Blade Speed (rpm):**8 4000**

Do You want to scale the Input Blade Thicknesses
Along the Span (Enter Yes or No):**n**

Enter Blade Description Starting Station # :**2**

Do You Need Local Ice Impact Damage Analysis?
(Enter Yes or No) :**y**
Do You Need Root Ice Damage Analysis?
(Enter Yes or No) :**y**
Enter Ice Piece Length, Width, and Thickness (inches) :**0.7 0.7 0.7**
Enter Ice Velocity (knots) :**100**

Ice Density is Defaulted to 8.42E-05 (lb.sec**2/in**4)
Enter Density Now or Hit Return to Accept Default Value:
Enter Starting and Ending Ice Impact Location
Along the Span as Fractions for Impact Modelling:**0.5 0.9**
Enter the Number of Consecutive Ice Impacts
(It Includes Geometry Update Following Each Impact):**1**

Do You Need Flutter Analysis?
(Enter Yes or No) :**y**
Enter No. Roots Calculated by Flutter Analysis :**5**
Enter Inlet Static Temperature (deg. F), and
Inlet Static Pressure (lbf/ft**2) :**32 2117**
Enter Relative Inlet Mach Number (> 1), and
Corresponding radius (inches) :**1.1 12.25**

Do You Need Resonance Margin Analysis?
(Enter Yes or No) :**y**

Do you Need Forcing Function Calculated?
(Enter Yes or No) :**y**
Enter Redline and Minimum Cruise Speeds (RPM) :**4100 3900**
Enter Number of Excitation Orders (max. 5):**3**
Enter 3 Excitation Order Nos. (1,2,3, etc.) :**1 2 3**

Enter Code for Type of Blade Construction
(0:solid; 1:hollow; 2:superhybrid; 3:composite) :**0**

Enter E11, E22, Nu12, G12, and Density
for Solid Blade:**16.5e06 16.5e06 0.3 6.34e06 0.00044**

Enter Ultimate Strengths (psi): Tension-11,
Compression-11, Tension-22, Compression-22, and
Shear-12 for Solid Blade:**74000 74000 74000 74000 44400**

The Blade Offsets are defined as..

$$x = ACLX*Z + BCLX*Z**2 + CCLX*Z**3$$

$$y = ACLY*Z + BCLY*Z**2 + CCLY*Z**3$$

where Z is spanwise variable

y is chordwise variable

and x is transverse variable

The Offsets are Defaulted to Zero, to Accept the Default Values Hit Return or Enter Now ACLX, BCLX, CCLX, ACLY, BCLY, and CCLY:

Pressure Data

This is the Third Section of the Input File Where Pressure Loading Data are Defined. If Pressure Loading is Applied, the User Has the Option of Either Providing Data Thru a File or Entering a Uniform Pressure in This Section. Refer to the User's Manual for Details.

Is there Any Pressure Loading (Enter Yes or No):y

Will the Pressure Data Be Supplied Thru a Data File
(Enter Yes or No) :n

The Pressure Entered Here is Uniform For All Elements
Enter the Value of the Element Pressure:5

Fatigue Life Data

This Section of the Input File is for Fatigue Data. If Fatigue Analysis is Desired, then Data Such as Static and Dynamic Stress Limits are Entered Here. Refer to the User's Manual for Details.

Do You Need to Enter Fatigue life Data for Forcing
Function Calculation? (Enter Yes or No):y
Enter Static and Dynamic Stress Limits (psi):75000 30000
Enter Multiple of Static Pressure:0
Enter Root Current, Reference, and Melting Temperatures (F):100 100 2000
Enter the Exponent:1
Enter Forcing Function Factor: 1

Boundary Conditions Data

Boundary Conditions Data Are Defaulted, i.e., All Degrees of Freedom at the Blade Root are Restrained. To Change the Defaulted Boundary Conditions, Refer to the User Manual, Section 2.0

The Input File Required to Run the BLASIM Code is Generated Under the Name BLASIM.INP. Use the Command or Job File Given in the User's Manual to Run the Code on VAX or CRAY XMP.

The input file generated by PREBLASIM and used directly to run BLASIM is listed below:

```

SR2 Unswept Titanium Blade
NASTRAN GEOMETRY TYPE                                CARD A2
4000.0                                                CARD A3
1                                                    CARD A4
2.0                                                CARD A6a
GRID      1      2.0600  0.0000 -0.4710  0.7267    CARD A6a
GRID      2      2.0600  0.0000 -0.1980  1.0125    CARD A6a
GRID      3      2.0600  0.0000  0.0000  1.0857    CARD A6a
GRID      4      2.0600  0.0000  0.1980  1.0125    CARD A6a
GRID      5      2.0600  0.0000  0.4710  0.7267    CARD A6a
GRID      6      2.7780  0.0650 -0.5500  0.6666    CARD A6a
GRID      7      2.7780  0.0510 -0.2190  0.7926    CARD A6a
GRID      8      2.7780  0.0240 -0.0200  0.8927    CARD A6a
GRID      9      2.7780 -0.0030  0.1980  0.8587    CARD A6a
GRID     10      2.7780  0.0000  0.4710  0.7465    CARD A6a
GRID     11      3.6840  0.4940 -1.5130  0.0990    CARD A6a
GRID     12      3.6840  0.2030 -0.6550  0.2737    CARD A6a
GRID     13      3.6840 -0.0540  0.1990  0.3339    CARD A6a
GRID     14      3.6840 -0.2780  1.0540  0.2339    CARD A6a
GRID     15      3.6840 -0.4710  1.9120  0.0774    CARD A6a
GRID     16      5.0360  0.6530 -1.5240  0.0688    CARD A6a
GRID     17      5.0360  0.2770 -0.6760  0.1804    CARD A6a
GRID     18      5.0360 -0.0700  0.1680  0.2059    CARD A6a
GRID     19      5.0360 -0.3900  1.0150  0.1343    CARD A6a
GRID     20      5.0360 -0.6840  1.8630  0.0356    CARD A6a
GRID     21      6.3890  0.7950 -1.5640  0.0486    CARD A6a
GRID     22      6.3890  0.3580 -0.7400  0.1198    CARD A6a
GRID     23      6.3890 -0.0450  0.0810  0.1447    CARD A6a
GRID     24      6.3890 -0.4260  0.9020  0.1122    CARD A6a
GRID     25      6.3890 -0.7760  1.7250  0.0340    CARD A6a
GRID     26      7.7420  0.8840 -1.4970  0.0362    CARD A6a
GRID     27      7.7420  0.4030 -0.7110  0.0891    CARD A6a
GRID     28      7.7420 -0.0490  0.0750  0.1064    CARD A6a
GRID     29      7.7420 -0.4800  0.8600  0.0835    CARD A6a
GRID     30      7.7420 -0.8830  1.6460  0.0260    CARD A6a
GRID     31      9.0940  0.9510 -1.4200  0.0285    CARD A6a
GRID     32      9.0940  0.4400 -0.6750  0.0702    CARD A6a
GRID     33      9.0940 -0.0500  0.0680  0.0837    CARD A6a
GRID     34      9.0940 -0.5250  0.8120  0.0651    CARD A6a
GRID     35      9.0940 -0.9780  1.5560  0.0207    CARD A6a
GRID     36     10.4470  0.9680 -1.2870  0.0233    CARD A6a
GRID     37     10.4470  0.4570 -0.6140  0.0575    CARD A6a
GRID     38     10.4470 -0.0450  0.0570  0.0684    CARD A6a
GRID     39     10.4470 -0.5400  0.7290  0.0533    CARD A6a
GRID     40     10.4470 -1.0260  1.4020  0.0173    CARD A6a
GRID     41     11.3480  0.8950 -1.1220  0.0193    CARD A6a
GRID     42     11.3480  0.4270 -0.5380  0.0484    CARD A6a
GRID     43     11.3480 -0.0370  0.0450  0.0576    CARD A6a
GRID     44     11.3480 -0.4980  0.6290  0.0449    CARD A6a
GRID     45     11.3480 -0.9550  1.2130  0.0148    CARD A6a
GRID     46     11.7990  0.8050 -0.9800  0.0137    CARD A6a
GRID     47     11.7990  0.3860 -0.4710  0.0366    CARD A6a
GRID     48     11.7990 -0.0310  0.0370  0.0435    CARD A6a
GRID     49     11.7990 -0.4460  0.5450  0.0341    CARD A6a
GRID     50     11.7990 -0.8600  1.0540  0.0107    CARD A6a
GRID     51     12.2500  0.3810 -0.4520  0.0082    CARD A6a
GRID     52     12.2500  0.1830 -0.2180  0.0283    CARD A6a
GRID     53     12.2500 -0.0140  0.0170  0.0336    CARD A6a
GRID     54     12.2500 -0.2110  0.2510  0.0265    CARD A6a
GRID     55     12.2500 -0.4080  0.4850  0.0066    CARD A6a
0.0      1.086      0.000      0.0                                CARD A9

```

												8.0	CARD A10
5	3	5	0	1	1	2	0	1	1.02307	1			CARD B1a
.0001	.0001	.000											CARD B1b
2	0.8927	5	0.1447	7	0.0837	9	0.057611	0.0336					CARD B2
		32.00000					1						CARD B3
1.10000	12.25000				2117.00000								CARD B4
4100.000	3900.000		3	1	2	3							CARD B5
0.70000	0.70000	0.70000	100.00000	0.000084	0.00001	0.00000							CARD B6b
0.50000	0.90000	16	40	1									CARD B7
0.165E+08	0.165E+08	0.30000	0.634E+07	0.00044									CARD B8
0.0000	0.0000	0.0000	0.0000	0.0000	0.0000	0.0000							CARD B9e
0.740E+05	0.740E+05	0.740E+05	0.740E+05	0.740E+05	0.444E+05	0.444E+05							CARD B11

ELEMENT PRESSURE DATA

PRESSURE	5.00												CARD D2
PRESSURE	5.00												CARD D2
PRESSURE	5.00												CARD D2
PRESSURE	5.00												CARD D2
PRESSURE	5.00												CARD D2
PRESSURE	5.00												CARD D2
PRESSURE	5.00												CARD D2
PRESSURE	5.00												CARD D2
PRESSURE	5.00												CARD D2
PRESSURE	5.00												CARD D2
PRESSURE	5.00												CARD D2
PRESSURE	5.00												CARD D2
PRESSURE	5.00												CARD D2
PRESSURE	5.00												CARD D2
PRESSURE	5.00												CARD D2
PRESSURE	5.00												CARD D2
PRESSURE	5.00												CARD D2
PRESSURE	5.00												CARD D2
PRESSURE	5.00												CARD D2
PRESSURE	5.00												CARD D2
PRESSURE	5.00												CARD D2
PRESSURE	5.00												CARD D2
PRESSURE	5.00												CARD D2
PRESSURE	5.00												CARD D2
PRESSURE	5.00												CARD D2
PRESSURE	5.00												CARD D2
PRESSURE	5.00												CARD D2
PRESSURE	5.00												CARD D2
PRESSURE	5.00												CARD D2
PRESSURE	5.00												CARD D2
PRESSURE	5.00												CARD D2
PRESSURE	5.00												CARD D2
PRESSURE	5.00												CARD D2
PRESSURE	5.00												CARD D2
PRESSURE	5.00												CARD D2
PRESSURE	5.00												CARD D2
PRESSURE	5.00												CARD D2
PRESSURE	5.00												CARD D2
PRESSURE	5.00												CARD D2
PRESSURE	5.00												CARD D2
PRESSURE	5.00												CARD D2
PRESSURE	5.00												CARD D2
PRESSURE	5.00												CARD D2
PRESSURE	5.00												CARD D2
PRESSURE	5.00												CARD D2
PRESSURE	5.00												CARD D2
PRESSURE	5.00												CARD D2
PRESSURE	5.00												CARD D2
PRESSURE	5.00												CARD D2

```

PRESSURE            5.00                    CARD D2
PRESSURE            5.00                    CARD D2
PRESSURE            5.00                    CARD D2
PRESSURE            5.00                    CARD D2
PRESSURE            5.00                    CARD D2
PRESSURE            5.00                    CARD D2
PRESSURE            5.00                    CARD D2
PRESSURE            5.00                    CARD D2
PRESSURE            5.00                    CARD D2
PRESSURE            5.00                    CARD D2
PRESSURE            5.00                    CARD D2
PRESSURE            5.00                    CARD D2
PRESSURE            5.00                    CARD D2
PRESSURE            5.00                    CARD D2
PRESSURE            5.00                    CARD D2
PRESSURE            5.00                    CARD D2
PRESSURE            5.00                    CARD D2
PRESSURE            5.00                    CARD D2
PRESSURE            5.00                    CARD D2
PRESSURE            5.00                    CARD D2
PRESSURE            5.00                    CARD D2
PRESSURE            5.00                    CARD D2
PRESSURE            5.00                    CARD D2
PRESSURE            5.00                    CARD D2
PRESSURE            5.00                    CARD D2
PRESSURE            5.00                    CARD D2
PRESSURE            5.00                    CARD D2
PRESSURE            5.00                    CARD D2
PRESSURE            5.00                    CARD D2
PRESSURE            5.00                    CARD D2
PRESSURE            5.00                    CARD D2
PRESSURE            5.00                    CARD D2
FATIGUE LIFE DATA
STATIC LIMIT        75000.0                 CARD E2
DYNAMIC LIMIT       30000.0                 CARD E3
MULTIPLE            0.0                    CARD E4
TMELT                2000.0                 CARD E5
TREF                 100.0                 CARD E6
TCURRENT            100.0                 CARD E7
EXPONENT             1.0                    CARD E8
FORCE                1.0                    CARD E9

```

A.3 Output File (Unit 30)

The output file generated by BLASIM and containing static, modal, ice impact, flutter, and fatigue output is given here. BLASIM provides analysis information prior and following each impact. This capability shows to what extent the characteristics of the blade have been altered due to ice impact.

```

BBBBBBB LL      AAAAAA SSSSSS IIIIIIII MM MM
BB  BB LL      AA AA SS          II  MMM MMM
BB  BB LL      AA AA SS          II  MM MM MM
BBBBBBB LL      AAAAAAAA SSSSSS II  MM MM
BB  BB LL      AA AA          SS  II  MM MM
BB  BB LL      AA AA          SS  II  MM MM
BBBBBBB LLLLLLL AA AA  SSSSSS IIIIIIII MM MM

```

BLade ASsessment for Ice iMpect

* * * * Initial Blade Geometry * * * *

```

Grid #      X      Y      Z      Thickness
-----  -----  -----  -----  -----

```

1	2.0600	0.0000	-0.4710	0.7267
2	2.0600	0.0000	-0.1980	1.0125
3	2.0600	0.0000	0.0000	1.0857
4	2.0600	0.0000	0.1980	1.0125
5	2.0600	0.0000	0.4710	0.7267
6	2.7780	0.0650	-0.5500	0.6666
7	2.7780	0.0510	-0.2190	0.7926
8	2.7780	0.0240	-0.0200	0.8927
9	2.7780	-0.0030	0.1980	0.8587
10	2.7780	0.0000	0.4710	0.7465
11	3.6840	0.4940	-1.5130	0.0990
12	3.6840	0.2030	-0.6550	0.2737
13	3.6840	-0.0540	0.1990	0.3339
14	3.6840	-0.2780	1.0540	0.2339
15	3.6840	-0.4710	1.9120	0.0774
16	5.0360	0.6530	-1.5240	0.0688
17	5.0360	0.2770	-0.6760	0.1804
18	5.0360	-0.0700	0.1680	0.2059
19	5.0360	-0.3900	1.0150	0.1343
20	5.0360	-0.6840	1.8630	0.0356
21	6.3890	0.7950	-1.5640	0.0486
22	6.3890	0.3580	-0.7400	0.1198
23	6.3890	-0.0450	0.0810	0.1447
24	6.3890	-0.4260	0.9020	0.1122
25	6.3890	-0.7760	1.7250	0.0340
26	7.7420	0.8840	-1.4970	0.0362
27	7.7420	0.4030	-0.7110	0.0891
28	7.7420	-0.0490	0.0750	0.1064
29	7.7420	-0.4800	0.8600	0.0835
30	7.7420	-0.8830	1.6460	0.0260
31	9.0940	0.9510	-1.4200	0.0285
32	9.0940	0.4400	-0.6750	0.0702
33	9.0940	-0.0500	0.0680	0.0837
34	9.0940	-0.5250	0.8120	0.0651
35	9.0940	-0.9780	1.5560	0.0207
36	10.4470	0.9680	-1.2870	0.0233
37	10.4470	0.4570	-0.6140	0.0575
38	10.4470	-0.0450	0.0570	0.0684
39	10.4470	-0.5400	0.7290	0.0533
40	10.4470	-1.0260	1.4020	0.0173
41	11.3480	0.8950	-1.1220	0.0193
42	11.3480	0.4270	-0.5380	0.0484
43	11.3480	-0.0370	0.0450	0.0576
44	11.3480	-0.4980	0.6290	0.0449
45	11.3480	-0.9550	1.2130	0.0148
46	11.7990	0.8050	-0.9800	0.0137
47	11.7990	0.3860	-0.4710	0.0366
48	11.7990	-0.0310	0.0370	0.0435
49	11.7990	-0.4460	0.5450	0.0341
50	11.7990	-0.8600	1.0540	0.0107
51	12.2500	0.3810	-0.4520	0.0082
52	12.2500	0.1830	-0.2180	0.0283
53	12.2500	-0.0140	0.0170	0.0336
54	12.2500	-0.2110	0.2510	0.0265
55	12.2500	-0.4080	0.4850	0.0066

```

** * * * * Tip Displacements * * * * *
Untwist          -1.1088

Uncamber         -0.3939
Max Tip Extension 0.0123
Max In Plane Displ 0.7026 0.1287

```

*** Resonance Margin Information ***
 Frequencies At 4000.2 rpm 157.48 489.16 761.59
 Frequencies At 4400.4 rpm 165.92 497.73 763.45

Red Line Speed-rpm = 4100.0 Min Cruise Speed-rpm = 3900.0

Frequency-cps (Red Line)	Frequency-cps (Min Cruise)	Margin (Red Line)	Margin (Min Cruise)	Margin (Max)	Excit. Order	Root Number
0.15955E+03	0.15543E+03	0.13349E+01	-0.13912E+01	0.13349E+01	1	1
0.15955E+03	0.15543E+03	0.16744E+00	-0.19560E+00	0.16744E+00	2	1
0.15955E+03	0.15543E+03	-0.22171E+00	0.20293E+00	0.20293E+00	3	1
0.49123E+03	0.48712E+03	0.61888E+01	-0.64941E+01	0.61888E+01	1	2
0.49123E+03	0.48712E+03	0.25944E+01	-0.27471E+01	0.25944E+01	2	2
0.49123E+03	0.48712E+03	0.13963E+01	-0.14980E+01	0.13963E+01	3	2
0.76204E+03	0.76115E+03	0.10152E+02	-0.10710E+02	0.10152E+02	1	3
0.76204E+03	0.76115E+03	0.45759E+01	-0.48550E+01	0.45759E+01	2	3
0.76204E+03	0.76115E+03	0.27172E+01	-0.29033E+01	0.27172E+01	3	3

***** Forced Response Output *****

*** At Minimum Cruise Speed of 3900.0 rpm ***

Root #	Order #	Steady Stress	Vibratory Stress	Allowed Vibratory Stress	PMGD
1	1	0.59837E+04	0.24555E+04	0.27607E+05	0.08895
1	2	0.59837E+04	0.20604E+04	0.27607E+05	0.07463
1	3	0.59837E+04	0.20366E+04	0.27607E+05	0.07377
2	1	0.23358E+04	0.22138E+04	0.29066E+05	0.07617
2	2	0.23358E+04	0.70496E+03	0.29066E+05	0.02425
2	3	0.23358E+04	0.67168E+03	0.29066E+05	0.02311
3	1	0.48133E+04	0.36208E+02	0.28075E+05	0.00129
3	2	0.48133E+04	0.25450E+02	0.28075E+05	0.00091
3	3	0.48133E+04	0.22648E+02	0.28075E+05	0.00081

*** At Redline (Max.) Speed of 4100.0 rpm ***

Root #	Order #	Steady Stress	Vibratory Stress	Allowed Vibratory Stress	PMGD
1	1	0.59837E+04	0.23549E+04	0.27607E+05	0.08530
1	2	0.59837E+04	0.19585E+04	0.27607E+05	0.07094
1	3	0.59837E+04	0.19341E+04	0.27607E+05	0.07006
2	1	0.23358E+04	0.24639E+04	0.29066E+05	0.08477
2	2	0.23358E+04	0.69798E+03	0.29066E+05	0.02401
2	3	0.23358E+04	0.66238E+03	0.29066E+05	0.02279
3	1	0.48133E+04	0.31913E+02	0.28075E+05	0.00114
3	2	0.48133E+04	0.25833E+02	0.28075E+05	0.00092
3	3	0.48133E+04	0.22749E+02	0.28075E+05	0.00081

Maximum Forced Response Margins For Each Mode

Mode	Margin
1	0.0889
2	0.0848
3	0.0013

***** FLUTTER OUTPUT *****

NASA FLUTTER ANALYSIS

MODE	CRIT. NODAL DIA.	AERO. DAMPING COEF.
1	-1	0.75980E+02
2	1	0.27765E+02

3 3 0.13432E+03

*** STRESS OUTPUT ***

ROOT STRESS (PSI) = 0.59837E+04

NUMBER OF BLADES = 0.80000E+01

Blade Analysis Due To The First Ice Impact

*** Ice Impact Location ***

Local Region Close To 50.00% Of The span Is At Radius = 7.742 inch
Local Region Close To 90.00% Of The Span Is At Radius = 11.348 inch

*** Ice Impact Analysis Local Coordinates and Thickness ***

Local Grid #	X	Y	Z	Thickness
1	7.7420	0.8840	-1.4970	0.0388
2	7.7420	0.6427	-1.1088	0.0718
3	7.7420	0.4068	-0.7174	0.0953
4	7.7420	0.1762	-0.3228	0.1094
5	7.7420	-0.0490	0.0750	0.1142
6	8.3425	0.9167	-1.4671	0.0334
7	8.3427	0.6681	-1.0866	0.0618
8	8.3428	0.4242	-0.7032	0.0821
9	8.3429	0.1847	-0.3169	0.0943
10	8.3429	-0.0501	0.0722	0.0983
11	8.9437	0.9447	-1.4303	0.0293
12	8.9437	0.6905	-1.0591	0.0543
13	8.9437	0.4400	-0.6855	0.0720
14	8.9438	0.1931	-0.3095	0.0827
15	8.9438	-0.0502	0.0689	0.0862
16	9.5455	0.9672	-1.3856	0.0264
17	9.5450	0.7092	-1.0258	0.0489
18	9.5447	0.4538	-0.6641	0.0649
19	9.5447	0.2011	-0.3004	0.0745
20	9.5447	-0.0491	0.0650	0.0776
21	10.1473	0.9744	-1.3258	0.0242
22	10.1463	0.7167	-0.9813	0.0449
23	10.1458	0.4606	-0.6354	0.0596
24	10.1456	0.2061	-0.2883	0.0684
25	10.1456	-0.0468	0.0601	0.0711
26	10.7480	0.9527	-1.2399	0.0220
27	10.7472	0.7026	-0.9177	0.0410
28	10.7467	0.4533	-0.5947	0.0544
29	10.7465	0.2048	-0.2709	0.0623
30	10.7465	-0.0428	0.0535	0.0648
31	11.3474	0.8951	-1.1221	0.0193
32	11.3474	0.6613	-0.8309	0.0363
33	11.3474	0.4281	-0.5393	0.0484
34	11.3474	0.1953	-0.2474	0.0555
35	11.3474	-0.0370	0.0450	0.0576

*** Ice Impact Input and Derived Parameters ***

Blade velocity at impact radius 3998.41 in/sec
Ice velocity 2025.37 in/sec (100.00 knots)
Ice equivalent radius 0.43 inch
Local impact reference node 16

Global corresponding impact node 31
 Impact radius at reference node 9.55 inch
 Impact angle 28.12 degrees
 Stagger angle 54.99 degrees
 Density 0.840E-04 lbm.sec^2/in^4

*** Out-of-Plane Impact Displacements ***

Local Grid #	Displacement	Local Grid #	Displacement
1	0.000000	2	0.000000
3	0.000000	4	0.000000
5	0.000000	6	-0.004714
7	0.015953	8	0.018654
9	0.009488	10	0.000000
11	-0.014553	12	0.023231
13	0.031157	14	0.015600
15	0.000000	16	-0.021353
17	0.024818	18	0.041884
19	0.020296	20	0.000000
21	-0.021474	22	0.026737
23	0.043128	24	0.021075
25	0.000000	26	-0.016921
27	0.025133	28	0.031741
29	0.016112	30	0.000000
31	0.000000	32	0.000000
33	0.000000	34	0.000000
35	0.000000		

*** Local Ice Impact Output ***

Maximum Leading Edge Strain % 0.10370E+01
 Time Of Occurence 0.21000E-03

*** Updated Blade Geometry Due To The First Ice Impact ***

Grid #	X	Y	Z	Thickness
1	2.0600	0.0000	-0.4710	0.7267
2	2.0600	0.0000	-0.1980	1.0125
3	2.0600	0.0000	0.0000	1.0857
4	2.0600	0.0000	0.1980	1.0125
5	2.0600	0.0000	0.4710	0.7267
6	2.7780	0.0650	-0.5500	0.6666
7	2.7780	0.0510	-0.2190	0.7926
8	2.7780	0.0240	-0.0200	0.8927
9	2.7780	-0.0030	0.1980	0.8587
10	2.7780	0.0000	0.4710	0.7465
11	3.6840	0.4940	-1.5130	0.2090
12	3.6840	0.2030	-0.6550	0.5779
13	3.6840	-0.0540	0.1990	0.7050
14	3.6840	-0.2780	1.0540	0.4939
15	3.6840	-0.4710	1.9120	0.1634
16	5.0360	0.6530	-1.5240	0.1420
17	5.0360	0.2770	-0.6760	0.3723
18	5.0360	-0.0700	0.1680	0.4250
19	5.0360	-0.3900	1.0150	0.2772
20	5.0360	-0.6840	1.8630	0.0735
21	6.3890	0.7950	-1.5640	0.0486
22	6.3890	0.3580	-0.7400	0.1198
23	6.3890	-0.0450	0.0810	0.1447

24	6.3890	-0.4260	0.9020	0.1122
25	6.3890	-0.7760	1.7250	0.0340
26	7.7420	0.8840	-1.4970	0.0388
27	7.7420	0.4030	-0.7110	0.0956
28	7.7420	-0.0490	0.0750	0.1142
29	7.7420	-0.4800	0.8600	0.0896
30	7.7420	-0.8830	1.6460	0.0279
31	9.0952	0.9377	-1.4292	0.0285
32	9.0927	0.4686	-0.6557	0.0702
33	9.0940	-0.0500	0.0680	0.0837
34	9.0940	-0.5250	0.8120	0.0651
35	9.0940	-0.9780	1.5560	0.0207
36	10.4481	0.9528	-1.2986	0.0232
37	10.4458	0.4870	-0.5915	0.0572
38	10.4470	-0.0450	0.0570	0.0680
39	10.4470	-0.5400	0.7290	0.0530
40	10.4470	-1.0260	1.4020	0.0172
41	11.3480	0.8950	-1.1220	0.0193
42	11.3480	0.4270	-0.5380	0.0484
43	11.3480	-0.0370	0.0450	0.0576
44	11.3480	-0.4980	0.6290	0.0449
45	11.3480	-0.9550	1.2130	0.0148
46	11.7990	0.8050	-0.9800	0.0144
47	11.7990	0.3860	-0.4710	0.0384
48	11.7990	-0.0310	0.0370	0.0456
49	11.7990	-0.4460	0.5450	0.0357
50	11.7990	-0.8600	1.0540	0.0112
51	12.2500	0.3810	-0.4520	0.0082
52	12.2500	0.1830	-0.2180	0.0283
53	12.2500	-0.0140	0.0170	0.0336
54	12.2500	-0.2110	0.2510	0.0265
55	12.2500	-0.4080	0.4850	0.0066

* * * * Root Ice Impact output * * * *

Root ice impact response (Mod. dist. crit.) 0.001
 At element number 15
 At layer number 1

** * * * * Tip Displacements * * * * *

Untwist -0.5961
 Uncamber -0.8136
 Max Tip Extension 0.0106
 Max In Plane Displ 0.6185 0.1189

* * * * Resonance Margin Information * * * *

Frequencies At 4000.2 rpm 159.07 518.40 759.46
 Frequencies At 4400.4 rpm 167.29 526.10 761.30

Red Line Speed-rpm = 4100.0 Min Cruise Speed-rpm = 3900.0

Frequency-cps (Red Line)	Frequency-cps (Min Cruise)	Margin (Red Line)	Margin (Min Cruise)	Margin (Max)	Excit. Order	Root Number
0.16108E+03	0.15707E+03	0.13573E+01	-0.14165E+01	0.13573E+01	1	1
0.16108E+03	0.15707E+03	0.17867E+00	-0.20825E+00	0.17867E+00	2	1
0.16108E+03	0.15707E+03	-0.21422E+00	0.19450E+00	0.19450E+00	3	1
0.52026E+03	0.51657E+03	0.66136E+01	-0.69472E+01	0.66136E+01	1	2
0.52026E+03	0.51657E+03	0.28068E+01	-0.29736E+01	0.28068E+01	2	2
0.52026E+03	0.51657E+03	0.15379E+01	-0.16491E+01	0.15379E+01	3	2
0.75990E+03	0.75902E+03	0.10120E+02	-0.10677E+02	0.10120E+02	1	3

0.75990E+03	0.75902E+03	0.45602E+01	-0.48386E+01	0.45602E+01	2	3
0.75990E+03	0.75902E+03	0.27068E+01	-0.28924E+01	0.27068E+01	3	3

***** Forced Response Output *****

*** At Minimum Cruise Speed of 3900.0 rpm ***

Root #	Order #	Steady Stress	Vibratory Stress	Allowed Vibratory Stress	PMGD
1	1	0.59757E+04	0.25063E+04	0.27610E+05	0.09078
1	2	0.59757E+04	0.21080E+04	0.27610E+05	0.07635
1	3	0.59757E+04	0.20881E+04	0.27610E+05	0.07563
2	1	0.23320E+04	0.21161E+04	0.29067E+05	0.07280
2	2	0.23320E+04	0.70120E+03	0.29067E+05	0.02412
2	3	0.23320E+04	0.67406E+03	0.29067E+05	0.02319
3	1	0.48062E+04	0.89648E+02	0.28078E+05	0.00319
3	2	0.48062E+04	0.58194E+02	0.28078E+05	0.00207
3	3	0.48062E+04	0.52939E+02	0.28078E+05	0.00189

*** At Redline (Max.) Speed of 4100.0 rpm ***

Root #	Order #	Steady Stress	Vibratory Stress	Allowed Vibratory Stress	PMGD
1	1	0.59757E+04	0.24085E+04	0.27610E+05	0.08723
1	2	0.59757E+04	0.20073E+04	0.27610E+05	0.07270
1	3	0.59757E+04	0.19867E+04	0.27610E+05	0.07196
2	1	0.23320E+04	0.23522E+04	0.29067E+05	0.08092
2	2	0.23320E+04	0.69562E+03	0.29067E+05	0.02393
2	3	0.23320E+04	0.66645E+03	0.29067E+05	0.02293
3	1	0.48062E+04	0.78288E+02	0.28078E+05	0.00279
3	2	0.48062E+04	0.58967E+02	0.28078E+05	0.00210
3	3	0.48062E+04	0.53177E+02	0.28078E+05	0.00189

Maximum Forced Response Margins For Each Mode

Mode	Margin
1	0.0908
2	0.0809
3	0.0032

***** FLUTTER OUTPUT *****

NASA FLUTTER ANALYSIS

MODE	CRIT. NODAL DIA.	AERO. DAMPING COEF.
1	-1	0.44625E+02
2	0	0.84673E+01
3	3	0.14345E+03

***** STRESS OUTPUT *****

ROOT STRESS (PSI) = 0.59757E+04

NUMBER OF BLADES = 0.80000E+01

A.4 Modal Analysis Results (Unit 45)

The modal analysis results are written to a file on logical unit 45. These data can be used to evaluate the mode shapes for pre-and-post-ice impact conditions. A listing of the modal analysis output file is given in this section. For each mode, the natural frequency and the global modal displacements T1, T2, and T3 (i.e. u, v, and w) are provided. The modal output file for the example used in this appendix is listed below:

```

MODAL PRINT FOR ROOT NUMBER 1      FREQUENCY (CPS)= 0.15748E+03
      GRID #      T1      T2      T3      PRE-IMPACT
1      0.00000 0.00000 0.00000
2      0.00000 0.00000 0.00000
3      0.00000 0.00000 0.00000
4      0.00000 0.00000 0.00000
5      0.00000 0.00000 0.00000
6      -0.00002 0.00012 0.00000
7      -0.00002 0.00015 0.00000
8      0.00000 0.00015 0.00000
9      0.00001 0.00015-0.00001
10     0.00001 0.00014-0.00001
11     -0.00046 0.00047-0.00015
12     -0.00016 0.00091 0.00000
13     0.00006 0.00097 0.00002
14     0.00021 0.00072-0.00006
15     0.00028 0.00017-0.00018
16     -0.00093 0.00374 0.00043
17     -0.00031 0.00444 0.00071
18     0.00014 0.00435 0.00066
19     0.00045 0.00373 0.00045
20     0.00066 0.00269 0.00010
21     -0.00254 0.01407 0.00343
22     -0.00072 0.01586 0.00467
23     0.00029 0.01570 0.00461
24     0.00087 0.01300 0.00332
25     0.00092 0.00720 0.00087
26     -0.00876 0.07407 0.03113
27     -0.00323 0.08015 0.03475
28     0.00073 0.07574 0.03221
29     0.00342 0.06246 0.02503
30     0.00364 0.03740 0.01225
31     -0.02219 0.23290 0.11633
32     -0.00945 0.23361 0.11694
33     0.00137 0.22121 0.10869
34     0.01008 0.19369 0.09102
35     0.01514 0.15449 0.06715
36     -0.03997 0.48077 0.26241
37     -0.01861 0.47185 0.25557
38     0.00170 0.45284 0.24129
39     0.02028 0.42070 0.21758
40     0.03639 0.37607 0.18536
41     -0.04677 0.68560 0.39000
42     -0.02222 0.66896 0.37664
43     0.00153 0.65069 0.36209
44     0.02440 0.62103 0.33868
45     0.04630 0.58718 0.31221
46     -0.04640 0.78782 0.45365
47     -0.02240 0.77290 0.44137
48     0.00128 0.75516 0.42682
49     0.02445 0.73028 0.40648
50     0.04716 0.70077 0.38248

```

51 -0.02410 0.87958 0.50825
 52 -0.01172 0.87098 0.50099
 53 0.00020 0.86136 0.49292
 54 0.01228 0.85127 0.48445
 55 0.02438 0.83963 0.47464

MODAL PRINT FOR ROOT NUMBER 2 FREQUENCY (CPS)= 0.48916E+03

GRID #	T1	T2	T3	PRE-IMPACT
1	0.00000	0.00000	0.00000	
2	0.00000	0.00000	0.00000	
3	0.00000	0.00000	0.00000	
4	0.00000	0.00000	0.00000	
5	0.00000	0.00000	0.00000	
6	0.00036	-0.00067	0.00021	
7	0.00020	-0.00081	0.00021	
8	0.00002	-0.00084	0.00018	
9	-0.00018	-0.00085	0.00022	
10	-0.00028	-0.00078	0.00024	
11	0.00355	-0.00307	0.00149	
12	0.00128	-0.00493	0.00082	
13	-0.00051	-0.00532	0.00072	
14	-0.00193	-0.00447	0.00097	
15	-0.00307	-0.00239	0.00144	
16	0.00589	-0.01968	0.00020	
17	0.00228	-0.02182	-0.00116	
18	-0.00087	-0.02170	-0.00120	
19	-0.00342	-0.02030	-0.00066	
20	-0.00534	-0.01729	0.00044	
21	0.01161	-0.06629	-0.01398	
22	0.00435	-0.06402	-0.01324	
23	-0.00117	-0.06463	-0.01347	
24	-0.00562	-0.06055	-0.01157	
25	-0.00826	-0.05614	-0.01006	
26	0.02542	-0.20986	-0.07675	
27	0.01014	-0.19204	-0.06597	
28	-0.00218	-0.18586	-0.06269	
29	-0.01264	-0.18432	-0.06169	
30	-0.01988	-0.17938	-0.05888	
31	0.03761	-0.37512	-0.15559	
32	0.01572	-0.32231	-0.11872	
33	-0.00262	-0.32024	-0.11688	
34	-0.02122	-0.34357	-0.13163	
35	-0.04402	-0.42074	-0.17897	
36	0.01638	-0.16401	0.01891	
37	0.00696	-0.13698	0.03912	
38	-0.00201	-0.15109	0.02837	
39	-0.01323	-0.20771	-0.01312	
40	-0.02916	-0.31198	-0.08805	
41	-0.00785	0.21035	0.31284	
42	-0.00440	0.21306	0.31483	
43	-0.00160	0.19093	0.29717	
44	-0.00046	0.12044	0.24143	
45	-0.00265	0.01442	0.15853	
46	-0.01929	0.44082	0.49442	
47	-0.01041	0.44327	0.49626	
48	-0.00144	0.41674	0.47443	
49	0.00626	0.35143	0.42102	
50	0.01195	0.25415	0.34216	
51	-0.01665	0.71077	0.70819	
52	-0.00880	0.69860	0.69792	
53	-0.00216	0.67750	0.68017	
54	0.00494	0.65270	0.65941	
55	0.01186	0.61818	0.63036	

MODAL PRINT FOR ROOT NUMBER 3 FREQUENCY (CPS)= 0.76159E+03

GRID #	T1	T2	T3	PRE-IMPACT
--------	----	----	----	------------

1	0.00000	0.00000	0.00000
2	0.00000	0.00000	0.00000
3	0.00000	0.00000	0.00000
4	0.00000	0.00000	0.00000
5	0.00000	0.00000	0.00000
6	0.00016	0.00007	0.00011
7	0.00004	-0.00011	0.00011
8	-0.00006	-0.00021	0.00010
9	-0.00010	-0.00032	0.00010
10	-0.00010	-0.00044	0.00011
11	0.00157	0.00232	0.00160
12	0.00043	-0.00003	0.00076
13	-0.00031	-0.00175	0.00031
14	-0.00071	-0.00322	-0.00001
15	-0.00093	-0.00474	-0.00033
16	0.00196	0.00462	0.00454
17	0.00051	-0.00083	0.00229
18	-0.00076	-0.00622	0.00003
19	-0.00154	-0.01107	-0.00180
20	-0.00174	-0.01427	-0.00272
21	0.00354	0.03480	0.02534
22	0.00022	0.00487	0.00757
23	-0.00207	-0.01516	-0.00168
24	-0.00314	-0.03410	-0.00992
25	-0.00211	-0.06158	-0.02389
26	-0.00198	0.15977	0.10590
27	-0.00292	0.06568	0.04925
28	-0.00553	-0.02289	-0.00243
29	-0.00723	-0.10338	-0.04761
30	-0.00752	-0.18413	-0.08829
31	-0.02088	0.49142	0.35050
32	-0.00946	0.18971	0.13862
33	-0.01044	-0.01118	0.00749
34	-0.01227	-0.19509	-0.10826
35	-0.02683	-0.45654	-0.27181
36	-0.01776	0.56023	0.43906
37	-0.01571	0.26403	0.21614
38	-0.01551	-0.02659	-0.00141
39	-0.01812	-0.27463	-0.18478
40	-0.01525	-0.42590	-0.29263
41	-0.02837	0.76944	0.63851
42	-0.01787	0.27606	0.24139
43	-0.02064	-0.09531	-0.05182
44	-0.02427	-0.41860	-0.30483
45	-0.03800	-0.76126	-0.57546
46	-0.02316	0.64933	0.55859
47	-0.01935	0.22027	0.20913
48	-0.02136	-0.15321	-0.09551
49	-0.02853	-0.48293	-0.36291
50	-0.03811	-0.76599	-0.58968
51	-0.02063	0.17390	0.18158
52	-0.01938	-0.02689	0.01380
53	-0.02238	-0.22158	-0.14692
54	-0.02563	-0.41094	-0.30391
55	-0.03388	-0.58416	-0.44748

MODAL PRINT FOR ROOT NUMBER 1 FREQUENCY (CPS)= 0.15907E+03

GRID #	T1	T2	T3	POST-IMPACT
1	0.00000	0.00000	0.00000	
2	0.00000	0.00000	0.00000	
3	0.00000	0.00000	0.00000	
4	0.00000	0.00000	0.00000	
5	0.00000	0.00000	0.00000	
6	-0.00002	0.00013	0.00000	
7	-0.00002	0.00016	0.00000	

8	0.00000	0.00016	0.00000
9	0.00002	0.00016	-0.00001
10	0.00001	0.00015	-0.00001
11	-0.00049	0.00050	-0.00017
12	-0.00017	0.00098	0.00000
13	0.00007	0.00105	0.00002
14	0.00022	0.00078	-0.00006
15	0.00029	0.00019	-0.00020
16	-0.00100	0.00403	0.00046
17	-0.00034	0.00478	0.00076
18	0.00016	0.00469	0.00071
19	0.00049	0.00403	0.00048
20	0.00070	0.00292	0.00011
21	-0.00269	0.01492	0.00357
22	-0.00079	0.01711	0.00503
23	0.00033	0.01692	0.00496
24	0.00094	0.01410	0.00362
25	0.00097	0.00804	0.00109
26	-0.00930	0.08053	0.03372
27	-0.00372	0.08732	0.03792
28	0.00085	0.08201	0.03495
29	0.00381	0.06869	0.02772
30	0.00413	0.04319	0.01469
31	-0.01981	0.24203	0.12077
32	-0.01525	0.24573	0.12258
33	0.00185	0.23708	0.11604
34	0.01103	0.21040	0.09886
35	0.01648	0.16993	0.07428
36	-0.03594	0.49683	0.26850
37	-0.02626	0.49247	0.26595
38	0.00265	0.47931	0.25526
39	0.02168	0.44643	0.23102
40	0.03794	0.39603	0.19461
41	-0.04645	0.69514	0.39025
42	-0.02079	0.68151	0.37929
43	0.00269	0.67299	0.37250
44	0.02574	0.64626	0.35134
45	0.04789	0.61059	0.32351
46	-0.04513	0.78758	0.44532
47	-0.02092	0.78019	0.43947
48	0.00249	0.77270	0.43337
49	0.02569	0.75192	0.41632
50	0.04844	0.72196	0.39187
51	-0.02266	0.88366	0.50351
52	-0.01029	0.87931	0.49993
53	0.00147	0.87396	0.49542
54	0.01347	0.86729	0.48978
55	0.02562	0.85729	0.48132

MODAL PRINT FOR ROOT NUMBER 2 FREQUENCY (CPS)= 0.51840E+03

GRID #	T1	T2	T3	POST-IMPACT
1	0.00000	0.00000	0.00000	
2	0.00000	0.00000	0.00000	
3	0.00000	0.00000	0.00000	
4	0.00000	0.00000	0.00000	
5	0.00000	0.00000	0.00000	
6	0.00045	-0.00079	0.00027	
7	0.00024	-0.00096	0.00026	
8	0.00003	-0.00099	0.00023	
9	-0.00021	-0.00099	0.00027	
10	-0.00035	-0.00091	0.00030	
11	0.00424	-0.00376	0.00177	
12	0.00154	-0.00582	0.00102	
13	-0.00060	-0.00621	0.00092	
14	-0.00232	-0.00516	0.00122	

15	-0.00374-0.00269	0.00177
16	0.00697-0.02326	-0.00018
17	0.00272-0.02552	-0.00119
18	-0.00099-0.02521	-0.00118
19	-0.00405-0.02342	-0.00049
20	-0.00642-0.01987	0.00080
21	0.01326-0.07627	-0.01569
22	0.00511-0.07392	-0.01485
23	-0.00117-0.07410	-0.01491
24	-0.00650-0.06870	-0.01246
25	-0.01016-0.06387	-0.01060
26	0.02803-0.22966	-0.08280
27	0.01080-0.21241	-0.07179
28	-0.00176-0.20263	-0.06588
29	-0.01372-0.19637	-0.06218
30	-0.02275-0.19032	-0.05883
31	0.04321-0.43497	-0.17827
32	0.01808-0.34544	-0.12530
33	-0.00034-0.31907	-0.10696
34	-0.02124-0.33577	-0.11799
35	-0.04765-0.42721	-0.17351
36	0.03056-0.26494	-0.03703
37	0.00389-0.13760	0.04767
38	0.00280-0.10979	0.07131
39	-0.01099-0.16269	0.03285
40	-0.03148-0.29721	-0.06402
41	0.00419	0.06815 0.21481
42	0.00767	0.16339 0.29090
43	0.00494	0.22326 0.33819
44	0.00289	0.18346 0.30612
45	-0.00163	0.07431 0.22131
46	-0.00481	0.28541 0.38313
47	0.00120	0.38576 0.46644
48	0.00549	0.44358 0.51388
49	0.01051	0.41678 0.49142
50	0.01341	0.31972 0.41203
51	-0.00554	0.65371 0.67988
52	0.00075	0.68523 0.70681
53	0.00531	0.70119 0.71987
54	0.01090	0.70638 0.72385
55	0.01739	0.68969 0.70944

MODAL PRINT FOR ROOT NUMBER 3 FREQUENCY (CPS)= 0.75946E+03

GRID #	T1	T2	T3	POST-IMPACT
1	0.00000	0.00000	0.00000	
2	0.00000	0.00000	0.00000	
3	0.00000	0.00000	0.00000	
4	0.00000	0.00000	0.00000	
5	0.00000	0.00000	0.00000	
6	0.00025-0.00012	0.00014		
7	0.00010-0.00035	0.00014		
8	-0.00005-0.00046	0.00012		
9	-0.00013-0.00056	0.00013		
10	-0.00015-0.00067	0.00015		
11	0.00250	0.00140	0.00193	
12	0.00077-0.00144	0.00091		
13	-0.00044-0.00327	0.00042		
14	-0.00119-0.00453	0.00016		
15	-0.00169-0.00551	-0.00004		
16	0.00355-0.00107	0.00427		
17	0.00115-0.00696	0.00181		
18	-0.00097-0.01234	-0.00047		
19	-0.00246-0.01694	-0.00220		
20	-0.00320-0.01948	-0.00287		
21	0.00689	0.01419	0.01986	

22	0.00143-0.01164	0.00415
23	-0.00239-0.03197	-0.00512
24	-0.00461-0.05034	-0.01300
25	-0.00454-0.07803	-0.02712
26	0.00367 0.11950	0.09278
27	-0.00075 0.03562	0.04220
28	-0.00634-0.05240	-0.00959
29	-0.00922-0.13111	-0.05403
30	-0.01064-0.21103	-0.09432
31	-0.01139 0.48411	0.34378
32	-0.01125 0.16245	0.14397
33	-0.01176-0.03577	0.00367
34	-0.01410-0.22039	-0.11235
35	-0.03024-0.48931	-0.28045
36	-0.01321 0.61937	0.48174
37	-0.01872 0.25440	0.24318
38	-0.01688-0.03426	0.00637
39	-0.01969-0.28852	-0.18121
40	-0.01685-0.44046	-0.28938
41	-0.02677 0.76262	0.64777
42	-0.01826 0.28840	0.26582
43	-0.02190-0.08267	-0.02714
44	-0.02557-0.41766	-0.28963
45	-0.03915-0.76656	-0.56524
46	-0.02304 0.65950	0.58150
47	-0.02029 0.24984	0.24762
48	-0.02256-0.12253	-0.05625
49	-0.02929-0.46370	-0.33324
50	-0.03865-0.75937	-0.57036
51	-0.02264 0.23394	0.24501
52	-0.02102 0.03405	0.07788
53	-0.02356-0.16377	-0.08585
54	-0.02628-0.35771	-0.24679
55	-0.03405-0.53717	-0.39571

The blade and the first three natural mode shapes before and after first ice impact are shown in Figures A.2 and A.3 respectively. As described earlier in Section 2.0, the finite element mesh of the blade consists of 11 spanwise and 5 chordwise stations. However, for the sake of clarity, 21x9 grid lines are shown in the mode shapes after interpolation of modal displacements.

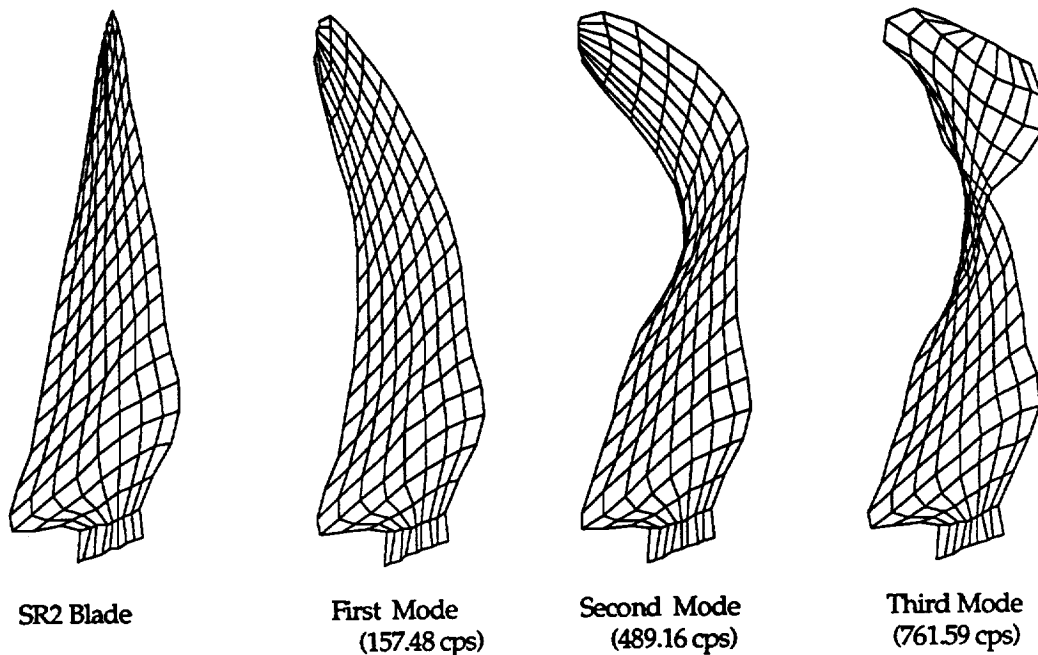

Figure A.2 Results of Dynamic Analysis from SR2 Titanium Blade Prior to Ice Impact

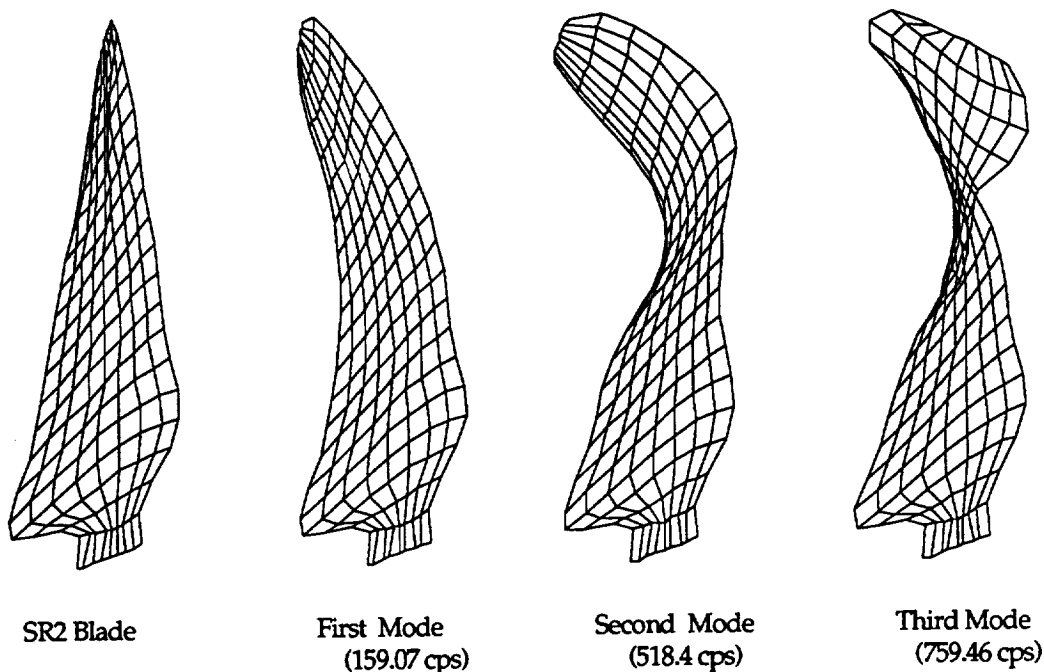

Figure A.3 Results of Dynamic Analysis from SR2 Titanium Blade After First Ice Impact

A.5 Parametric Study

For the SR-2 unswept titanium blade, parametric study is performed at 4000 rpm by varying ice speed. The average leading edge strain and the impact angle (relative to the chord) are plotted as a function of the ice speed in the Figure A.2.

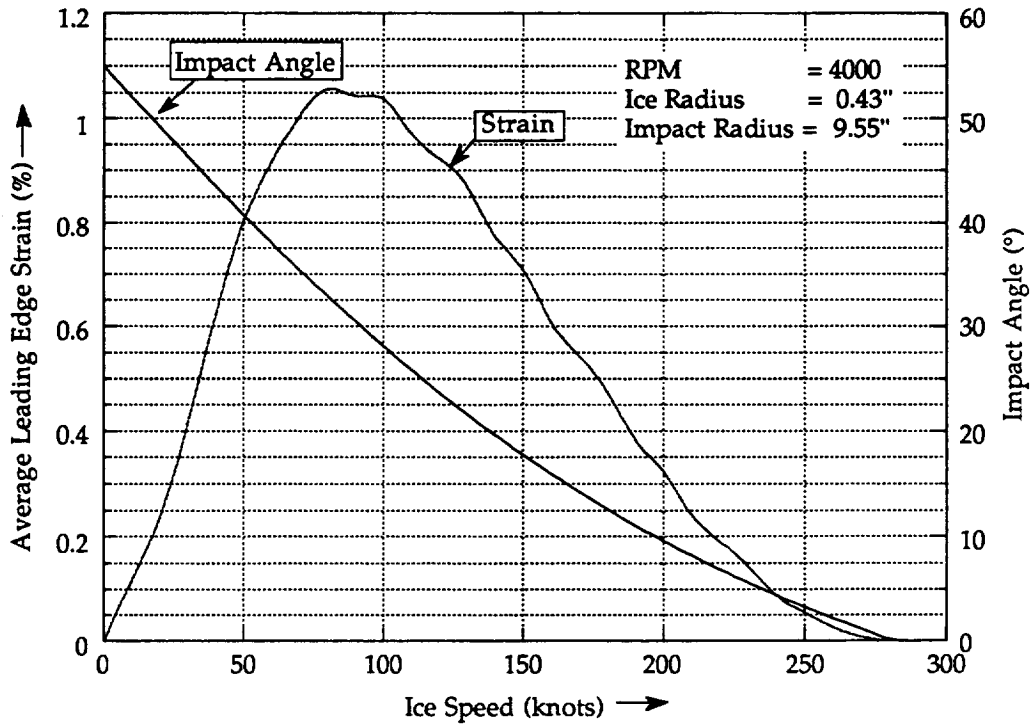

Figure A.4 Variation of Average Leading Edge Strain and Impact Angle with Ice Speed

APPENDIX B

FIBER-MATRIX OPTION USAGE

B.1 Introduction

For the composite blade, the ply properties can be input directly or determined based on the given fiber-matrix combination. In this appendix, the usage of the fiber-matrix option is demonstrated. BLASIM uses ICAN (Integrated Composite ANalyzer) to generate the ply properties. The material properties of fiber and matrices are picked from a dedicated Data Bank (See Section B.4). This data base reduces the burden on the user in preparing the necessary data for the constituent properties.

An SR2 composite blade is used to demonstrate the usage of ICAN. The blade is subjected to centrifugal load of 4000 rpm and uniform pressure of 3 psi. The ice impact conditions are the same as those used in Section A.1. Three fibers and matrices combinations are entered with keywords as described in the table below:

<u>Material</u>	<u>Keyword</u>
Titanium Fiber	TITF
Graphite Fiber	T300
Titanium matrix	TIT6
Epoxy Matrix	EPOC

B.2 Interactive Session

The BLASIM interactive input generator, PREBLASIM, is used to create the input file for this demonstration case. The finite element grid file used here is the same as the one listed in Section A.2. The interactive session as displayed on a computer screen when running PREBLASIM is listed below:

```
BBBBBBB LL          AAAAAA SSSSSS IIIIIIII MM MM
BB BB LL          AA AA SS          II MM MM MM
BB BB LL          AA AA SS          II MM MM MM
BBBBBBB LL          AAAAAAAA SSSSSS II MM MM MM
BB BB LL          AA AA SS          II MM MM
BB BB LL          AA AA SS          II MM MM
BBBBBBB LLLLLLLL AA AA SSSSSS IIIIIIII MM MM
```

Preprocessor for
Blades ASsessment for ice IMPact

This Module Will Automatically Generate Input File for BLASIM Program. The Blade Geometry May be Defined in One of the Following Forms: a) Provide the Blade Finite Element Nodal Coordinates and their Thicknesses Thru a File, b) Supply the Airfoil Coordinates Thru a File, c) Select one of the Built-in NACA Airfoils. Any Wrong Entries or Defaulted Data May be Changed by Editing the Input File Created by the Program. To

Find the Data Card Number, Variable Name and its Description,
See Appendix A of the BLASIM User's Manual.

....hit return to continue....

Summary of the Information Needed to Run the BLASIM Interactive
Program is Given Here:

Description of Entry	CARD #
1. Definition of Blade Geometry, Choices are:	
a. Finite element coordinates & Thicknesses	A6a
b. Airfoil Coordinates & Stagger Angles	A6,A7,A8
c. Construction of Blade With Built-in Airfoil Models	None
2. Number of Blades & Operating Speed	A10,A3
3. Blade Root Angle & Thickness, Broach Angle	A9
4. Option for Local & Root Ice Impact Analysis	B1a,B6b
5. Option for Flutter Analysis	B1a,B3,B4
6. Option for Forcing Function Calculation	B1a
7. Redline & Minimum Cruise Speeds	B5
8. Number of Excitation Orders & Order Number	B5
9. Blade Type & Elastic Material Properties	B1a,B8,B11
10. Pressure Data (Optional)	D2
11. Fatigue Life Data (Optional)	E

....hit return to continue....

Enter Title of the Problem :
SR2 Modified Composite Blade

The Terms in Bold are User's Entries

Blade Description and Analyses Options

This is the First Section of the Input File. The Blade Geometry
Speed, and Analyses Options are Defined Here. The User is Expected
to Provide the Blade Finite Element Nodal or Airfoil Coordinates
Thru a Data File or Select an Airfoil Model to Construct the Blade.
See the User's Manual For More Details.

Airfoil or Finite Element Input (A/F)? :f
Enter format of the Grid coord. (x,y,z & thickness):**24x,4f8.4**
Enter Geometry Filename :**grid.dat**
Enter Number of Blades, and Blade Speed (rpm):**8 4000**

Do You want to scale the Input Blade Thicknesses
Along the Span (Enter Yes or No):n

Enter Blade Description Starting Station # :2

Do You Need Local Ice Impact Damage Analysis?
(Enter Yes or No) :y

Do You Need Root Ice Damage Analysis?
(Enter Yes or No) :y

Enter Ice Piece Length, Width, and Thickness (inches) :**0.7 0.7 0.7**
Enter Ice Velocity (knots) :**100**

Ice Density is Defaulted to 8.42E-05 (lb.sec**2/in**4)

Enter Density Now or Hit Return to Accept Default Value:
 Enter Starting and Ending Ice Impact Location
 Along the Span as Fractions for Impact Modelling:0.5 0.9

Enter the Number of Consecutive Ice Impacts
 (It Includes Geometry Update Following Each Impact):1
 Do You Need Flutter Analysis?

(Enter Yes or No) :y

Enter No. Roots Calculated by Flutter Analysis :5

Enter Inlet Static Temperature (deg. F), and
 Inlet Static Pressure (lbf/ft**2) :32 2117

Enter Relative Inlet Mach Number (> 1), and
 Corresponding radius (inches) :1.1 12.25

Do You Need Resonance Margin Analysis?

(Enter Yes or No) :y

Do you Need Forcing Function Calculated?

(Enter Yes or No) :y

Enter Redline and Minimum Cruise Speeds (RPM) :4200 3800

Enter Number of Excitation Orders (max. 5):3

Enter 3 Excitation Order Nos. (1,2,3, etc.) :1 2 3

Enter Code for Type of Blade Construction
 (0:solid; 1:hollow; 2:superhybrid; 3:composite):3

Enter No. of Materials (max.: 7) :3

For Composite Blade Option in BLASIM, Select One of the
 Following:

- 1. Supply Material Elastic Properties
- or 2. Generate Material Elastic Properties Using ICAN
 (Integrated Composite ANalyzer) Based on Specified
 Fiber and Matrix

Enter Choice:2

The Table Below Lists the Fiber and Matrix Types Available
 in the ICAN Data Bank. The Properties for Each Composite will
 be Determined Based on the Selected Fiber/Matrix Combinations.

Fiber Keyword & Description	Matrix Keyword & Description
T300 Graphite	EPOC Epoxy
P100 Graphite (High Modulus)	IMLS Inter. Mod. Low Str.
HMSF Surface Fiber (High Mod.)	IMHS Inter. Mod. High Str.
SGLA S-Glass	HMHS High Mod. High Str.
EGLA E-Glass	POLY Polyimide
SW4M Stainless Steel Wire	SSLA Stainless Steel
TITF Titanium	TIT6 Titanium
TUNG Tungsten	FECR Superalloy
SICA Silicon Carbide on Alum.	ALTX Aluminum
BOR5 Boron (5 Mil. Diameter)	BORM Boron

Note: Keywords for Fiber and Matrix Can be Entered in
 Lower or Upper Case.

Enter Keyword for the Fiber for Material # 1:t300
Enter Keyword for the Matrix for Material # 1:tit6
Enter the Fiber Volume Ratio for Material # 1:0.4
Enter the Void Volume Ratio for Material # 1:0
Enter the Use and Cure Temperatures for Material # 1:70 70
Enter the Percentage of Moisture Content by Weight for
Material # 1: 0.0

Enter Keyword for the Fiber for Material # 2:t300
Enter Keyword for the Matrix for Material # 2:epoc
Enter the Fiber Volume Ratio for Material # 2:0.4
Enter the Void Volume Ratio for Material # 2:0
Enter the Use and Cure Temperatures for Material # 2:70 70
Enter the Percentage of Moisture Content by Weight for
Material # 2: 0.0

Enter Keyword for the Fiber for Material # 3:titf
Enter Keyword for the Matrix for Material # 3:tit6
Enter the Fiber Volume Ratio for Material # 3:0.4
Enter the Void Volume Ratio for Material # 3:0
Enter the Use and Cure Temperatures for Material # 3:70 70
Enter the Percentage of Moisture Content by Weight for
Material # 3: 0.0

Note: the Blade Cross Section is made of
---- Symmetric Composite and Material Layers
are Numbered from Outside to Inside

For Composite Blade ---

Enter Thickness of Material # 1 :0.005
Enter Thickness of Material # 2 :0.02
Enter Thickness of Material # 3 :0.005

Enter First Ply Orientation in Material # 1 :0
Enter First Ply Orientation in Material # 2 :45
Enter First Ply Orientation in Material # 3 :0

Enter Ply Thickness in Material # 1 :0.005
Enter Ply Thickness in Material # 2 :0.02
Enter Ply Thickness in Material # 3 :0.005

The Blade Offsets are defined as..

$$x = ACLX*Z + BCLX*Z**2 + CCLX*Z**3$$

$$y = ACLY*Z + BCLY*Z**2 + CCLY*Z**3$$

where Z is spanwise variable

y is chordwise variable

and x is transverse variable

The Offsets are Defaulted to Zero, to Accept the
Default Values Hit Return or Enter Now ACLX, BCLX,
CCLX, ACLY, BCLY, and CCLY:

Pressure Data

This is the Third Section of the Input File Where Pressure Loading
Data are Defined. If Pressure Loading is Applied, the User Has the
Option of Either Providing Data Thru a File or Entering a Uniform

Pressure in This Section. Refer to the User's Manual for Details.

Is there Any Pressure Loading (Enter Yes or No):y

Will the Pressure Data Be Supplied Thru a Data File
(Enter Yes or No) :n

The Pressure Entered Here is Uniform For All Elements
Enter the Value of the Element Pressure:3

Fatigue Life Data

This Section of the Input File is for Fatigue Data. If Fatigue Analysis is Desired, then Data Such as Static and Dynamic Stress Limits are Entered Here. Refer to the User's Manual for Details.

Do You Need to Enter Fatigue life Data for Forcing Function Calculation? (Enter Yes or No):y
Enter Static and Dynamic Stress Limits (psi):75000 30000
Enter Multiple of Static Pressure:0
Enter Root Current, Reference, and Melting Temperatures (F):70 70 2000
Enter the Exponent:1
Enter the Forcing Function:1

Boundary Conditions Data

Boundary Conditions Data Are Defaulted, i.e., All Degrees of Freedom at the Blade Root are Restrained. To Change the Defaulted Boundary Conditions, Refer to the User Manual, Section 2.0

The Input File Required to Run the BLASIM Code is Generated Under the Name BLASIM.INP. Use the Command or Job File Given in the User's Manual to Run the Code on VAX or CRAY XMP.

B.3 Input File

The input file generated by PREBLASIM for this demonstration case is listed here:

```
SR2 Modified Composite Blade
NASTRAN GEOMETRY TYPE
  4000.0          3.0  400.0
11              2.0
GRID      .1      2.0600  0.0000 -0.4710  0.7267
GRID      2      2.0600  0.0000 -0.1980  1.0125
GRID      3      2.0600  0.0000  0.0000  1.0857
GRID      4      2.0600  0.0000  0.1980  1.0125
GRID      5      2.0600  0.0000  0.4710  0.7267
GRID      6      2.7780  0.0650 -0.5500  0.6666
GRID      7      2.7780  0.0510 -0.2190  0.7926
GRID      8      2.7780  0.0240 -0.0200  0.8927
GRID      9      2.7780 -0.0030  0.1980  0.8587
GRID     10      2.7780  0.0000  0.4710  0.7465
GRID     11      3.6840  0.4940 -1.5130  0.0990
GRID     12      3.6840  0.2030 -0.6550  0.2737
GRID     13      3.6840 -0.0540  0.1990  0.3339
GRID     14      3.6840 -0.2780  1.0540  0.2339
GRID     15      3.6840 -0.4710  1.9120  0.0774
CARD A2
CARD A3
CARD A4
CARD A6a
CARD A6a
CARD A6a
CARD A6a
CARD A6a
CARD A6a
CARD A6a
CARD A6a
CARD A6a
CARD A6a
CARD A6a
CARD A6a
CARD A6a
CARD A6a
CARD A6a
CARD A6a
CARD A6a
```

GRID	16	5.0360	0.6530	-1.5240	0.0688							CARD A6a
GRID	17	5.0360	0.2770	-0.6760	0.1804							CARD A6a
GRID	18	5.0360	-0.0700	0.1680	0.2059							CARD A6a
GRID	19	5.0360	-0.3900	1.0150	0.1343							CARD A6a
GRID	20	5.0360	-0.6840	1.8630	0.0356							CARD A6a
GRID	21	6.3890	0.7950	-1.5640	0.0486							CARD A6a
GRID	22	6.3890	0.3580	-0.7400	0.1198							CARD A6a
GRID	23	6.3890	-0.0450	0.0810	0.1447							CARD A6a
GRID	24	6.3890	-0.4260	0.9020	0.1122							CARD A6a
GRID	25	6.3890	-0.7760	1.7250	0.0340							CARD A6a
GRID	26	7.7420	0.8840	-1.4970	0.0362							CARD A6a
GRID	27	7.7420	0.4030	-0.7110	0.0891							CARD A6a
GRID	28	7.7420	-0.0490	0.0750	0.1064							CARD A6a
GRID	29	7.7420	-0.4800	0.8600	0.0835							CARD A6a
GRID	30	7.7420	-0.8830	1.6460	0.0260							CARD A6a
GRID	31	9.0940	0.9510	-1.4200	0.0285							CARD A6a
GRID	32	9.0940	0.4400	-0.6750	0.0702							CARD A6a
GRID	33	9.0940	-0.0500	0.0680	0.0837							CARD A6a
GRID	34	9.0940	-0.5250	0.8120	0.0651							CARD A6a
GRID	35	9.0940	-0.9780	1.5560	0.0207							CARD A6a
GRID	36	10.4470	0.9680	-1.2870	0.0233							CARD A6a
GRID	37	10.4470	0.4570	-0.6140	0.0575							CARD A6a
GRID	38	10.4470	-0.0450	0.0570	0.0684							CARD A6a
GRID	39	10.4470	-0.5400	0.7290	0.0533							CARD A6a
GRID	40	10.4470	-1.0260	1.4020	0.0173							CARD A6a
GRID	41	11.3480	0.8950	-1.1220	0.0193							CARD A6a
GRID	42	11.3480	0.4270	-0.5380	0.0484							CARD A6a
GRID	43	11.3480	-0.0370	0.0450	0.0576							CARD A6a
GRID	44	11.3480	-0.4980	0.6290	0.0449							CARD A6a
GRID	45	11.3480	-0.9550	1.2130	0.0148							CARD A6a
GRID	46	11.7990	0.8050	-0.9800	0.0137							CARD A6a
GRID	47	11.7990	0.3860	-0.4710	0.0366							CARD A6a
GRID	48	11.7990	-0.0310	0.0370	0.0435							CARD A6a
GRID	49	11.7990	-0.4460	0.5450	0.0341							CARD A6a
GRID	50	11.7990	-0.8600	1.0540	0.0107							CARD A6a
GRID	51	12.2500	0.3810	-0.4520	0.0082							CARD A6a
GRID	52	12.2500	0.1830	-0.2180	0.0283							CARD A6a
GRID	53	12.2500	-0.0140	0.0170	0.0336							CARD A6a
GRID	54	12.2500	-0.2110	0.2510	0.0265							CARD A6a
GRID	55	12.2500	-0.4080	0.4850	0.0066							CARD A6a
		0.0	1.086	0.000	0.0							CARD A9
									8.0			CARD A10
	5	3	5	3	3	1	2	0	1	1.02307	1	CARD B1a
	.0001	.0001	.000									CARD B1b
	2	0.8927	5	0.1447	7	0.0837	9	0.057611	0.0336			CARD B2
			32.00000					1				CARD B3
	1.10000	12.25000						2117.00000				CARD B4
	4200.000	3800.000		3	1	2	3					CARD B5
	0.70000	0.70000		0.70000	100.00000	0.000084	0.00001	0.00000				CARD B6b
	0.50000	0.90000	16	40			1					CARD B7
MATCARD	TITFTIT6	0.40	0.00	70.00	70.00	0.00						CARD B8b
MATCARD	T300EPOC	0.40	0.00	70.00	70.00	0.00						CARD B8b
MATCARD	TITFTIT6	0.40	0.00	70.00	70.00	0.00						CARD B8b
	0.0050	0.0200	0.0050									CARD B9b
	0.0000	45.0000	0.0000									CARD B9c
	0.0050	0.0200	0.0050									CARD B9d
	0.0000	0.0000	0.0000	0.0000	0.0000	0.0000						CARD B9e
ELEMENT PRESSURE DATA												
PRESSURE		3.00										CARD D2
PRESSURE		3.00										CARD D2
PRESSURE		3.00										CARD D2
PRESSURE		3.00										CARD D2
PRESSURE		3.00										CARD D2
PRESSURE		3.00										CARD D2

PRESSURE	3.00	CARD D2
PRESSURE	3.00	CARD D2
PRESSURE	3.00	CARD D2
PRESSURE	3.00	CARD D2
PRESSURE	3.00	CARD D2
PRESSURE	3.00	CARD D2
PRESSURE	3.00	CARD D2
PRESSURE	3.00	CARD D2
PRESSURE	3.00	CARD D2
PRESSURE	3.00	CARD D2
PRESSURE	3.00	CARD D2
FATIGUE LIFE DATA		
STATIC LIMIT	75000.0	CARD E2
DYNAMIC LIMIT	30000.0	CARD E3
MULTIPLE	0.0	CARD E4
TMELT	2000.0	CARD E5
TREF	70.0	CARD E6
TCURRENT	70.0	CARD E7
EXPONENT	1.0	CARD E8
FORCING FUNCTION	1.0	CARD E9

The output file obtained by running BLASIM using this input file will be very similar to the one shown in Section A.3, hence it is not shown here.

B.4 ICAN Data Bank

The ICAN Data Bank is divided into two parts: fiber material properties and matrix material properties. The Data Bank that is currently available with the BLASIM code is listed below:

FIBER PROPERTIES

ADHX FIBER EQUIVALENT PROPERTIES OF ADHESIVE.

Number of fibers per end	Nf	1	number
Filament equivalent diameter	df	0.500E-03	inches
Weight density	Rhof	0.400E-01	lb/in**3
Normal moduli (11)	Ef11	0.300E+06	psi
Normal moduli (22)	Ef22	0.300E+06	psi
Poisson's ratio (12)	Nuf12	0.450E+00	non-dim
Poisson's ratio (23)	Nuf23	0.450E+00	non-dim
Shear moduli (12)	Gf12	0.103E+06	psi
Shear moduli (23)	Gf23	0.103E+06	psi
Thermal expansion coef. (11)	Alfaf11	0.570E-04	in/in/F
Thermal expansion coef. (22)	Alfaf22	0.570E-04	in/in/F
Heat conductivity (11)	Kf11	0.125E+01	BTU-in/hr/in**2/F
Heat conductivity (22)	Kf22	0.125E+01	BTU-in/hr/in**2/F
Heat capacity	Cf	0.250E+00	BTU/lb/F
Fiber tensile strength	SfT	0.800E+04	psi
Fiber compressive strength	SfC	0.150E+05	psi

ADHF FIBER EQUIVALENT PROPERTIES OF ADHESIVE.

Number of fibers per end	Nf	1	number
Filament equivalent diameter	df	0.500E-03	inches
Weight density	Rhof	0.400E-01	lb/in**3
Normal moduli (11)	Ef11	0.300E+06	psi
Normal moduli (22)	Ef22	0.300E+06	psi
Poisson's ratio (12)	Nuf12	0.450E+00	non-dim
Poisson's ratio (23)	Nuf23	0.450E+00	non-dim
Shear moduli (12)	Gf12	0.103E+06	psi
Shear moduli (23)	Gf23	0.103E+06	psi
Thermal expansion coef. (11)	Alfaf11	0.360E-04	in/in/F
Thermal expansion coef. (22)	Alfaf22	0.360E-04	in/in/F
Heat conductivity (11)	Kf11	0.125E+01	BTU-in/hr/in**2/F

Heat conductivity (22)	Kf22	0.125E+01	BTU-in/hr/in**2/F
Heat capacity	Cf	0.250E+00	BTU/lb/F
Fiber tensile strength	SfT	0.710E+04	psi
Fiber compressive strength	SfC	0.140E+05	psi

HALF

Number of fibers per end	Nf	10000	number
Filament equivalent diameter	df	0.300E-03	inches
Weight density	Rhof	0.815E-03	lb/in**3
Normal moduli (11)	Ef11	0.890E+05	psi
Normal moduli (22)	Ef22	0.371E+05	psi
Poisson"s ratio (12)	Nuf12	0.300E+00	non-dim
Poisson"s ratio (23)	Nuf23	0.300E+00	non-dim
Shear moduli (12)	Gf12	0.114E+05	psi
Shear moduli (23)	Gf23	0.171E+05	psi
Thermal expansion coef. (11)	Alfaf11	0.126E-04	in/in/F
Thermal expansion coef. (22)	Alfaf22	0.126E-04	in/in/F
Heat conductivity (11)	Kf11	0.518E-01	BTU-in/hr/in**2/F
Heat conductivity (22)	Kf22	0.259E-01	BTU-in/hr/in**2/F
Heat capacity	Cf	0.220E+00	BTU/lb/F
Fiber tensile strength	SfT	0.400E+06	psi
Fiber compressive strength	SfC	0.400E+06	psi

F185 ISOTROPIC SOLID . MARCH 4, 1990.

Number of fibers per end	Nf	3000	number
Filament equivalent diameter	df	0.300E-03	inches
Weight density	Rhof	0.443E-01	lb/in**3
Normal moduli (11)	Ef11	0.491E+08	psi
Normal moduli (22)	Ef22	0.491E+08	psi
Poisson"s ratio (12)	Nuf12	0.300E+00	non-dim
Poisson"s ratio (23)	Nuf23	0.300E+00	non-dim
Shear moduli (12)	Gf12	0.189E+08	psi
Shear moduli (23)	Gf23	0.189E+08	psi
Thermal expansion coef. (11)	Alfaf11	0.219E-05	in/in/F
Thermal expansion coef. (22)	Alfaf22	0.219E-05	in/in/F
Heat conductivity (11)	Kf11	0.250E+00	BTU-in/hr/in**2/F
Heat conductivity (22)	Kf22	0.250E+00	BTU-in/hr/in**2/F
Heat capacity	Cf	0.125E+01	BTU/lb/F
Fiber tensile strength	SfT	0.650E+04	psi
Fiber compressive strength	SfC	0.210E+05	psi

F186 ISOTROPIC SOLID . MARCH 4, 1990.

Number of fibers per end	Nf	3000	number
Filament equivalent diameter	df	0.300E-03	inches
Weight density	Rhof	0.443E-01	lb/in**3
Normal moduli (11)	Ef11	0.243E+08	psi
Normal moduli (22)	Ef22	0.243E+08	psi
Poisson"s ratio (12)	Nuf12	0.300E+00	non-dim
Poisson"s ratio (23)	Nuf23	0.300E+00	non-dim
Shear moduli (12)	Gf12	0.935E+07	psi
Shear moduli (23)	Gf23	0.935E+07	psi
Thermal expansion coef. (11)	Alfaf11	0.345E-05	in/in/F
Thermal expansion coef. (22)	Alfaf22	0.345E-05	in/in/F
Heat conductivity (11)	Kf11	0.250E+00	BTU-in/hr/in**2/F
Heat conductivity (22)	Kf22	0.250E+00	BTU-in/hr/in**2/F
Heat capacity	Cf	0.125E+01	BTU/lb/F
Fiber tensile strength	SfT	0.650E+04	psi
Fiber compressive strength	SfC	0.210E+05	psi

T300 GRAPHITE FIBER.

Number of fibers per end	Nf	3000	number
Filament equivalent diameter	df	0.300E-03	inches
Weight density	Rhof	0.640E-01	lb/in**3
Normal moduli (11)	Ef11	0.320E+08	psi

Normal moduli (22)	Ef22	0.200E+07	psi
Poisson"s ratio (12)	Nuf12	0.200E+00	non-dim
Poisson"s ratio (23)	Nuf23	0.250E+00	non-dim
Shear moduli (12)	Gf12	0.130E+07	psi
Shear moduli (23)	Gf23	0.700E+06	psi
Thermal expansion coef. (11)	Alfaf11	-.550E-06	in/in/F
Thermal expansion coef. (22)	Alfaf22	0.560E-05	in/in/F
HEAT CONDUCTIVITY (11)	KF11	0.403E+03	BTU-IN/HR/IN**2/F
HEAT CONDUCTIVITY (22)	KF22	0.403E+02	BTU-IN/HR/IN**2/F
Heat capacity	Cf	0.170E+00	BTU/lb/F
Fiber tensile strength	SfT	0.350E+06	psi
Fiber compressive strength	SfC	0.300E+06	psi

DALE TO CHECK DALE BROWN'S DATA

Number of fibers per end	Nf	3000	number
Filament equivalent diameter	df	0.226E-03	inches
Weight density	Rhof	0.533E-01	lb/in**3
Normal moduli (11)	Ef11	0.807E+08	psi
Normal moduli (22)	Ef22	0.229E+08	psi
Poisson"s ratio (12)	Nuf12	0.197E+00	non-dim
Poisson"s ratio (23)	Nuf23	0.325E+00	non-dim
Shear moduli (12)	Gf12	0.420E+07	psi
Shear moduli (23)	Gf23	0.769E+06	psi
Thermal expansion coef. (11)	Alfaf11	0.238E-04	in/in/F
Thermal expansion coef. (22)	Alfaf22	0.183E-04	in/in/F
Heat conductivity (11)	Kf11	0.250E+03	BTU-in/hr/in**2/F
Heat conductivity (22)	Kf22	0.546E+03	BTU-in/hr/in**2/F
Heat capacity	Cf	0.145E+01	BTU/lb/F
Fiber tensile strength	SfT	0.539E+06	psi
Fiber compressive strength	SfC	0.256E+06	psi

MOD2 GRAPHITE FIBER - INTERMEDIATE MODULUS.

Number of fibers per end	Nf	10000	number
Filament equivalent diameter	df	0.300E-03	inches
Weight density	Rhof	0.630E-01	lb/in**3
Normal moduli (11)	Ef11	0.380E+08	psi
Normal moduli (22)	Ef22	0.110E+07	psi
Poisson"s ratio (12)	Nuf12	0.200E+00	non-dim
Poisson"s ratio (23)	Nuf23	0.250E+00	non-dim
Shear moduli (12)	Gf12	0.150E+07	psi
Shear moduli (23)	Gf23	0.800E+06	psi
Thermal expansion coef. (11)	Alfaf11	-.550E-06	in/in/F
Thermal expansion coef. (22)	Alfaf22	0.560E-05	in/in/F
HEAT CONDUCTIVITY (11)	KF11	0.403E+01	BTU-IN/HR/IN**2/F
HEAT CONDUCTIVITY (22)	KF22	0.403E+00	BTU-IN/HR/IN**2/F
Heat capacity	Cf	0.170E+00	BTU/lb/F
Fiber tensile strength	SfT	0.350E+06	psi
Fiber compressive strength	SfC	0.250E+06	psi

MOD1 GRAPHITE FIBER - HIGH MODULUS.

Number of fibers per end	Nf	10000	number
Filament equivalent diameter	df	0.300E-03	inches
Weight density	Rhof	0.720E-01	lb/in**3
Normal moduli (11)	Ef11	0.600E+08	psi
Normal moduli (22)	Ef22	0.900E+06	psi
Poisson"s ratio (12)	Nuf12	0.200E+00	non-dim
Poisson"s ratio (23)	Nuf23	0.250E+00	non-dim
Shear moduli (12)	Gf12	0.110E+07	psi
Shear moduli (23)	Gf23	0.700E+06	psi
Thermal expansion coef. (11)	Alfaf11	-.550E-06	in/in/F
Thermal expansion coef. (22)	Alfaf22	0.560E-05	in/in/F
HEAT CONDUCTIVITY (11)	KF11	0.403E+01	BTU-IN/HR/IN**2/F
HEAT CONDUCTIVITY (22)	KF22	0.403E+00	BTU-IN/HR/IN**2/F
Heat capacity	Cf	0.170E+00	BTU/lb/F

Fiber tensile strength	SfT	0.250E+06	psi
Fiber compressive strength	SfC	0.200E+06	psi
HMSF HIGH MODULUS SURFACE TREATED FIBER.			
Number of fibers per end	Nf	10000	number
Filament equivalent diameter	df	0.300E-03	inches
Weight density	Rhof	0.703E-01	lb/in**3
Normal moduli (11)	Ef11	0.550E+08	psi
Normal moduli (22)	Ef22	0.900E+06	psi
Poisson"s ratio (12)	Nuf12	0.200E+00	non-dim
Poisson"s ratio (23)	Nuf23	0.250E+00	non-dim
Shear moduli (12)	Gf12	0.110E+07	psi
Shear moduli (23)	Gf23	0.700E+06	psi
Thermal expansion coef. (11)	Alfaf11	-.550E-06	in/in/F
Thermal expansion coef. (22)	Alfaf22	0.560E-05	in/in/F
HEAT CONDUCTIVITY (11)	KF11	0.403E+01	BTU-IN/HR/IN**2/F
HEAT CONDUCTIVITY (22)	KF22	0.403E+00	BTU-IN/HR/IN**2/F
Heat capacity	Cf	0.170E+00	BTU/lb/F
Fiber tensile strength	SfT	0.280E+06	psi
Fiber compressive strength	SfC	0.200E+06	psi

HT-S			
Number of fibers per end	Nf	10000	number
Filament equivalent diameter	df	0.300E-03	inches
Weight density	Rhof	0.640E-01	lb/in**3
Normal moduli (11)	Ef11	0.320E+08	psi
Normal moduli (22)	Ef22	0.250E+07	psi
Poisson"s ratio (12)	Nuf12	0.200E+00	non-dim
Poisson"s ratio (23)	Nuf23	0.250E+00	non-dim
Shear moduli (12)	Gf12	0.150E+07	psi
Shear moduli (23)	Gf23	0.100E+07	psi
Thermal expansion coef. (11)	Alfaf11	-.550E-06	in/in/F
Thermal expansion coef. (22)	Alfaf22	0.560E-05	in/in/F
HEAT CONDUCTIVITY (11)	KF11	0.403E+01	BTU-IN/HR/IN**2/F
HEAT CONDUCTIVITY (22)	KF22	0.403E+00	BTU-IN/HR/IN**2/F
Heat capacity	Cf	0.170E+00	BTU/lb/F
Fiber tensile strength	SfT	0.350E+06	psi
Fiber compressive strength	SfC	0.300E+06	psi

AS-- GRAPHITE FIBER.			
Number of fibers per end	Nf	10000	number
Filament equivalent diameter	df	0.300E-03	inches
Weight density	Rhof	0.630E-01	lb/in**3
Normal moduli (11)	Ef11	0.310E+08	psi
Normal moduli (22)	Ef22	0.200E+07	psi
Poisson"s ratio (12)	Nuf12	0.200E+00	non-dim
Poisson"s ratio (23)	Nuf23	0.250E+00	non-dim
Shear moduli (12)	Gf12	0.200E+07	psi
Shear moduli (23)	Gf23	0.100E+07	psi
Thermal expansion coef. (11)	Alfaf11	-.550E-06	in/in/F
Thermal expansion coef. (22)	Alfaf22	0.560E-05	in/in/F
HEAT CONDUCTIVITY (11)	KF11	0.403E+01	BTU-IN/HR/IN**2/F
HEAT CONDUCTIVITY (22)	KF22	0.403E+00	BTU-IN/HR/IN**2/F
Heat capacity	Cf	0.170E+00	BTU/lb/F
Fiber tensile strength	SfT	0.400E+06	psi
Fiber compressive strength	SfC	0.400E+06	psi

BOR4 BORON FIBER - 4 MIL DIAMETER.			
Number of fibers per end	Nf	1	number
Filament equivalent diameter	df	0.400E-02	inches
Weight density	Rhof	0.950E-01	lb/in**3
Normal moduli (11)	Ef11	0.580E+08	psi
Normal moduli (22)	Ef22	0.580E+08	psi
Poisson"s ratio (12)	Nuf12	0.200E+00	non-dim

Poisson's ratio (23)	Nuf23	0.200E+00	non-dim
Shear moduli (12)	Gf12	0.242E+08	psi
Shear moduli (23)	Gf23	0.242E+08	psi
Thermal expansion coef. (11)	Alfaf11	0.280E-05	in/in/F
Thermal expansion coef. (22)	Alfaf22	0.280E-05	in/in/F
Heat conductivity (11)	Kf11	0.155E+01	BTU-in/hr/in**2/F
Heat conductivity (22)	Kf22	0.155E+01	BTU-in/hr/in**2/F
Heat capacity	Cf	0.310E+00	BTU/lb/F
Fiber tensile strength	SfT	0.600E+06	psi
Fiber compressive strength	SfC	0.700E+06	psi

SGLA S- GLASS FIBER.

Number of fibers per end	Nf	204	number
Filament equivalent diameter	df	0.360E-03	inches
Weight density	Rhof	0.900E-01	lb/in**3
Normal moduli (11)	Ef11	0.124E+08	psi
Normal moduli (22)	Ef22	0.124E+08	psi
Poisson's ratio (12)	Nuf12	0.200E+00	non-dim
Poisson's ratio (23)	Nuf23	0.200E+00	non-dim
Shear moduli (12)	Gf12	0.517E+07	psi
Shear moduli (23)	Gf23	0.517E+07	psi
Thermal expansion coef. (11)	Alfaf11	0.280E-05	in/in/F
Thermal expansion coef. (22)	Alfaf22	0.280E-05	in/in/F
HEAT CONDUCTIVITY (11)	KF11	0.625E+00	BTU-IN/HR/IN**2/F
HEAT CONDUCTIVITY (22)	KF22	0.625E+00	BTU-IN/HR/IN**2/F
Heat capacity	Cf	0.170E+00	BTU/lb/F
Fiber tensile strength	SfT	0.360E+06	psi
Fiber compressive strength	SfC	0.300E+06	psi

KEVL KEVLAR FIBER.

Number of fibers per end	Nf	580	number
Filament equivalent diameter	df	0.460E-03	inches
Weight density	Rhof	0.530E-01	lb/in**3
Normal moduli (11)	Ef11	0.220E+08	psi
Normal moduli (22)	Ef22	0.600E+06	psi
Poisson's ratio (12)	Nuf12	0.350E+00	non-dim
Poisson's ratio (23)	Nuf23	0.350E+00	non-dim
Shear moduli (12)	Gf12	0.420E+06	psi
Shear moduli (23)	Gf23	0.220E+06	psi
Thermal expansion coef. (11)	Alfaf11	-.220E-05	in/in/F
Thermal expansion coef. (22)	Alfaf22	0.300E-04	in/in/F
Heat conductivity (11)	Kf11	0.170E+01	BTU-in/hr/in**2/F
Heat conductivity (22)	Kf22	0.170E+01	BTU-in/hr/in**2/F
Heat capacity	Cf	0.250E+00	BTU/lb/F
Fiber tensile strength	SfT	0.400E+06	psi
Fiber compressive strength	SfC	0.750E+05	psi

BOR5 BORON FIBER - 5 MIL DIAMETER.

Number of fibers per end	Nf	1	number
Filament equivalent diameter	df	0.560E-02	inches
Weight density	Rhof	0.950E-01	lb/in**3
Normal moduli (11)	Ef11	0.580E+08	psi
Normal moduli (22)	Ef22	0.580E+08	psi
Poisson's ratio (12)	Nuf12	0.200E+00	non-dim
Poisson's ratio (23)	Nuf23	0.200E+00	non-dim
Shear moduli (12)	Gf12	0.242E+08	psi
Shear moduli (23)	Gf23	0.242E+08	psi
Thermal expansion coef. (11)	Alfaf11	0.280E-05	in/in/F
Thermal expansion coef. (22)	Alfaf22	0.280E-05	in/in/F
Heat conductivity (11)	Kf11	0.155E+01	BTU-in/hr/in**2/F
Heat conductivity (22)	Kf22	0.155E+01	BTU-in/hr/in**2/F
Heat capacity	Cf	0.310E+00	BTU/lb/F
Fiber tensile strength	SfT	0.600E+06	psi
Fiber compressive strength	SfC	0.700E+06	psi

BOR8 BORON FIBER - 8 MIL DIAMETER.

Number of fibers per end	Nf	1	number
Filament equivalent diameter	df	0.800E-02	inches
Weight density	Rhof	0.950E-01	lb/in**3
Normal moduli (11)	Ef11	0.580E+08	psi
Normal moduli (22)	Ef22	0.580E+08	psi
Poisson"s ratio (12)	Nuf12	0.200E+00	non-dim
Poisson"s ratio (23)	Nuf23	0.200E+00	non-dim
Shear moduli (12)	Gf12	0.242E+08	psi
Shear moduli (23)	Gf23	0.242E+08	psi
Thermal expansion coef. (11)	Alfaf11	0.280E-05	in/in/F
Thermal expansion coef. (22)	Alfaf22	0.280E-05	in/in/F
Heat conductivity (11)	Kf11	0.155E+01	BTU-in/hr/in**2/F
Heat conductivity (22)	Kf22	0.155E+01	BTU-in/hr/in**2/F
Heat capacity	Cf	0.310E+00	BTU/lb/F
Fiber tensile strength	SfT	0.600E+06	psi
Fiber compressive strength	SfC	0.700E+06	psi

EGLA E-GLASS FIBER.

Number of fibers per end	Nf	204	number
Filament equivalent diameter	df	0.360E-03	inches
Weight density	Rhof	0.900E-01	lb/in**3
Normal moduli (11)	Ef11	0.105E+08	psi
Normal moduli (22)	Ef22	0.105E+08	psi
Poisson"s ratio (12)	Nuf12	0.200E+00	non-dim
Poisson"s ratio (23)	Nuf23	0.200E+00	non-dim
Shear moduli (12)	Gf12	0.437E+07	psi
Shear moduli (23)	Gf23	0.437E+07	psi
Thermal expansion coef. (11)	Alfaf11	0.280E-05	in/in/F
Thermal expansion coef. (22)	Alfaf22	0.280E-05	in/in/F
HEAT CONDUCTIVITY (11)	KF11	0.625E+00	BTU-IN/HR/IN**2/F
HEAT CONDUCTIVITY (22)	KF22	0.625E+00	BTU-IN/HR/IN**2/F
Heat capacity	Cf	0.170E+00	BTU/lb/F
Fiber tensile strength	SfT	0.360E+06	psi
Fiber compressive strength	SfC	0.360E+06	psi

SW4M STAINLESS STEEL WIRE.

Number of fibers per end	Nf	1	number
Filament equivalent diameter	df	0.400E-02	inches
Weight density	Rhof	0.278E+00	lb/in**3
Normal moduli (11)	Ef11	0.290E+08	psi
Normal moduli (22)	Ef22	0.290E+08	psi
Poisson"s ratio (12)	Nuf12	0.300E+00	non-dim
Poisson"s ratio (23)	Nuf23	0.300E+00	non-dim
Shear moduli (12)	Gf12	0.112E+08	psi
Shear moduli (23)	Gf23	0.112E+08	psi
Thermal expansion coef. (11)	Alfaf11	0.560E-05	in/in/F
Thermal expansion coef. (22)	Alfaf22	0.560E-05	in/in/F
Heat conductivity (11)	Kf11	0.108E+03	BTU-in/hr/in**2/F
Heat conductivity (22)	Kf22	0.108E+03	BTU-in/hr/in**2/F
Heat capacity	Cf	0.120E+00	BTU/lb/F
Fiber tensile strength	SfT	0.160E+06	psi
Fiber compressive strength	SfC	0.160E+06	psi

TITF TITANIUM FIBER.

Number of fibers per end	Nf	1	number
Filament equivalent diameter	df	0.430E-02	inches
Weight density	Rhof	0.161E+00	lb/in**3
Normal moduli (11)	Ef11	0.166E+08	psi
Normal moduli (22)	Ef22	0.166E+08	psi
Poisson"s ratio (12)	Nuf12	0.305E+00	non-dim
Poisson"s ratio (23)	Nuf23	0.305E+00	non-dim
Shear moduli (12)	Gf12	0.636E+07	psi

Shear moduli (23)	Gf23	0.636E+07	psi
Thermal expansion coef. (11)	Alfaf11	0.571E-05	in/in/F
Thermal expansion coef. (22)	Alfaf22	0.571E-05	in/in/F
Heat conductivity (11)	Kf11	0.100E+01	BTU-in/hr/in**2/F
Heat conductivity (22)	Kf22	0.100E+01	BTU-in/hr/in**2/F
Heat capacity	Cf	0.127E+00	BTU/lb/F
Fiber tensile strength	SfT	0.120E+06	psi
Fiber compressive strength	SfC	0.120E+06	psi

ADH1 ADHESIVE.

Number of fibers per end	Nf	1	number
Filament equivalent diameter	df	0.360E-03	inches
Weight density	Rhof	0.420E-01	lb/in**3
Normal moduli (11)	Ef11	0.211E+06	psi
Normal moduli (22)	Ef22	0.211E+06	psi
Poisson"s ratio (12)	Nuf12	0.410E+00	non-dim
Poisson"s ratio (23)	Nuf23	0.410E+00	non-dim
Shear moduli (12)	Gf12	0.760E+06	psi
Shear moduli (23)	Gf23	0.760E+06	psi
Thermal expansion coef. (11)	Alfaf11	0.410E-04	in/in/F
Thermal expansion coef. (22)	Alfaf22	0.410E-04	in/in/F
Heat conductivity (11)	Kf11	0.126E+01	BTU-in/hr/in**2/F
Heat conductivity (22)	Kf22	0.126E+01	BTU-in/hr/in**2/F
Heat capacity	Cf	0.260E+00	BTU/lb/F
Fiber tensile strength	SfT	0.600E+04	psi
Fiber compressive strength	SfC	0.100E+05	psi

TUNG TUNGSTEN FIBER (W-1.5%THO2).

Number of fibers per end	Nf	1	number
Filament equivalent diameter	df	0.600E-02	inches
Weight density	Rhof	0.697E+00	lb/in**3
Normal moduli (11)	Ef11	0.521E+08	psi
Normal moduli (22)	Ef22	0.521E+08	psi
Poisson"s ratio (12)	Nuf12	0.290E+00	non-dim
Poisson"s ratio (23)	Nuf23	0.290E+00	non-dim
Shear moduli (12)	Gf12	0.202E+08	psi
Shear moduli (23)	Gf23	0.202E+08	psi
Thermal expansion coef. (11)	Alfaf11	0.244E-05	in/in/F
Thermal expansion coef. (22)	Alfaf22	0.244E-05	in/in/F
Heat conductivity (11)	Kf11	0.828E+01	BTU-in/hr/in**2/F
Heat conductivity (22)	Kf22	0.828E+01	BTU-in/hr/in**2/F
Heat capacity	Cf	0.316E-01	BTU/lb/F
Fiber tensile strength	SfT	0.355E+06	psi
Fiber compressive strength	SfC	0.355E+06	psi

SICA SICA FIBER (W-1.5%THO2).

Number of fibers per end	Nf	1	number
Filament equivalent diameter	df	0.600E-02	inches
Weight density	Rhof	0.697E+00	lb/in**3
Normal moduli (11)	Ef11	0.580E+08	psi
Normal moduli (22)	Ef22	0.580E+08	psi
Poisson"s ratio (12)	Nuf12	0.250E+00	non-dim
Poisson"s ratio (23)	Nuf23	0.250E+00	non-dim
Shear moduli (12)	Gf12	0.232E+08	psi
Shear moduli (23)	Gf23	0.232E+08	psi
Thermal expansion coef. (11)	Alfaf11	0.270E-05	in/in/F
Thermal expansion coef. (22)	Alfaf22	0.270E-05	in/in/F
Heat conductivity (11)	Kf11	0.828E+01	BTU-in/hr/in**2/F
Heat conductivity (22)	Kf22	0.828E+01	BTU-in/hr/in**2/F
Heat capacity	Cf	0.316E-01	BTU/lb/F
Fiber tensile strength	SfT	0.355E+06	psi
Fiber compressive strength	SfC	0.355E+06	psi

P-75 HIGH MODULUS GRAPHITE FIBER

Number of fibers per end	Nf	10000	number
Filament equivalent diameter	df	0.390E-03	inches
Weight density	Rhof	0.720E-01	lb/in**3
Normal moduli (11)	Ef11	0.750E+08	psi
Normal moduli (22)	Ef22	0.900E+06	psi
Poisson"s ratio (12)	Nuf12	0.200E+00	non-dim
Poisson"s ratio (23)	Nuf23	0.250E+00	non-dim
Shear moduli (12)	Gf12	0.110E+07	psi
Shear moduli (23)	Gf23	0.700E+06	psi
Thermal expansion coef. (11)	Alfaf11	-.700E-06	in/in/F
Thermal expansion coef. (22)	Alfaf22	0.560E-05	in/in/F
Heat conductivity (11)	Kf11	0.900E+02	BTU-in/hr/in**2/F
Heat conductivity (22)	Kf22	0.580E+02	BTU-in/hr/in**2/F
Heat capacity	Cf	0.170E+00	BTU/lb/F
Fiber tensile strength	SfT	0.225E+06	psi
Fiber compressive strength	SfC	0.100E+06	psi

P100 HIGH MODULUS GRAPHITE FIBER

Number of fibers per end	Nf	10000	number
Filament equivalent diameter	df	0.390E-03	inches
Weight density	Rhof	0.780E-01	lb/in**3
Normal moduli (11)	Ef11	0.105E+09	psi
Normal moduli (22)	Ef22	0.900E+06	psi
Poisson"s ratio (12)	Nuf12	0.200E+00	non-dim
Poisson"s ratio (23)	Nuf23	0.250E+00	non-dim
Shear moduli (12)	Gf12	0.110E+07	psi
Shear moduli (23)	Gf23	0.700E+06	psi
Thermal expansion coef. (11)	Alfaf11	-.900E-06	in/in/F
Thermal expansion coef. (22)	Alfaf22	0.560E-05	in/in/F
Heat conductivity (11)	Kf11	0.250E+02	BTU-in/hr/in**2/F
Heat conductivity (22)	Kf22	0.174E+01	BTU-in/hr/in**2/F
Heat capacity	Cf	0.170E+00	BTU/lb/F
Fiber tensile strength	SfT	0.325E+06	psi
Fiber compressive strength	SfC	0.200E+06	psi

SICA SILICON CARBIDE ON ALUMINUM. SEPT 7, 1987. (6)

Number of fibers per end	Nf	1	number
Filament equivalent diameter	df	0.560E-02	inches
Weight density	Rhof	0.110E+00	lb/in**3
Normal moduli (11)	Ef11	0.620E+08	psi
Normal moduli (22)	Ef22	0.620E+08	psi
Poisson"s ratio (12)	Nuf12	0.300E+00	non-dim
Poisson"s ratio (23)	Nuf23	0.300E+00	non-dim
Shear moduli (12)	Gf12	0.238E+08	psi
Shear moduli (23)	Gf23	0.238E+08	psi
Thermal expansion coef. (11)	Alfaf11	0.180E-05	in/in/F
Thermal expansion coef. (22)	Alfaf22	0.180E-05	in/in/F
Heat conductivity (11)	Kf11	0.750E+00	BTU-in/hr/in**2/F
Heat conductivity (22)	Kf22	0.750E+00	BTU-in/hr/in**2/F
Heat capacity	Cf	0.290E+00	BTU/lb/F
Fiber tensile strength	SfT	0.500E+06	psi
Fiber compressive strength	SfC	0.650E+06	psi

OVER END OF FIBER PROPERTIES

MATRIX PROPERTIES

DALM DALE BROWN'S MATRIX OCT. 24, 1990.

Weight density	Rhom	0.475E-01	lb/in**3
Normal modulus	Em	0.449E+06	psi
Poisson"s ratio	Num	0.186E+00	non-dim
Thermal expansion coef.	Alfa m	0.292E-04	in/in/F
Matrix heat conductivity	Km	0.453E+00	BTU-in/hr/in**2/F
Heat capacity	Cm	0.213E+00	BTU/lb/F
Matrix tensile strength	SmT	0.425E+05	psi

Matrix compressive strength	SmC	0.337E+05	psi
Matrix shear strength	SmS	0.271E+05	psi
Allowable tensile strain	eps mT	0.120E+00	in/in
Allowable compr. strain	eps mC	0.120E+00	in/in
Allowable shear strain	eps mS	0.120E+00	in/in
Allowable torsional strain	eps mTOR	0.120E+00	in/in
Void heat conductivity	kv	0.190E-01	BTU-in/hr/in**2/F
Glass transition temperature	Tgdr	0.364E+03	F

BORM BORON MATRIX. AUG 22 1990 (3)

Weight density	Rhom	0.950E-01	lb/in**3
Normal modulus	Em	0.580E+08	psi
Poisson"s ratio	Num	0.200E+00	non-dim
Thermal expansion coef.	Alfa m	0.280E-05	in/in/F
Matrix heat conductivity	Km	0.155E+01	BTU-in/hr/in**2/F
Heat capacity	Cm	0.310E+00	BTU/lb/F
Matrix tensile strength	SmT	0.600E+06	psi
Matrix compressive strength	SmC	0.700E+06	psi
Matrix shear strength	SmS	0.100E+06	psi
Allowable tensile strain	eps mT	0.120E+00	in/in
Allowable compr. strain	eps mC	0.120E+00	in/in
Allowable shear strain	eps mS	0.120E+00	in/in
Allowable torsional strain	eps mTOR	0.120E+00	in/in
Void heat conductivity	kv	0.190E-01	BTU-in/hr/in**2/F
Glass transition temperature	Tgdr	0.180E+04	F

TI15 TITANIUM MATRIX. AUG 25, 1988. (3)

Weight density	Rhom	0.172E+00	lb/in**3
Normal modulus	Em	0.123E+08	psi
Poisson"s ratio	Num	0.320E+00	non-dim
Thermal expansion coef.	Alfa m	0.450E-05	in/in/F
Matrix heat conductivity	Km	0.390E+00	BTU-in/hr/in**2/F
Heat capacity	Cm	0.120E+00	BTU/lb/F
Matrix tensile strength	SmT	0.130E+06	psi
Matrix compressive strength	SmC	0.130E+06	psi
Matrix shear strength	SmS	0.910E+05	psi
Allowable tensile strain	eps mT	0.120E+00	in/in
Allowable compr. strain	eps mC	0.120E+00	in/in
Allowable shear strain	eps mS	0.120E+00	in/in
Allowable torsional strain	eps mTOR	0.120E+00	in/in
Void heat conductivity	kv	0.190E-01	BTU-in/hr/in**2/F
Glass transition temperature	Tgdr	0.180E+04	F

ADHM EQUIVALENT MATRIX PROPS. FOR ADHESIVE.

Weight density	Rhom	0.400E-01	lb/in**3
Normal modulus	Em	0.300E+06	psi
Poisson"s ratio	Num	0.450E+00	non-dim
Thermal expansion coef.	Alfa m	0.360E-04	in/in/F
Matrix heat conductivity	Km	0.125E+01	BTU-in/hr/in**2/F
Heat capacity	Cm	0.250E+00	BTU/lb/F
Matrix tensile strength	SmT	0.710E+04	psi
Matrix compressive strength	SmC	0.140E+05	psi
Matrix shear strength	SmS	0.710E+04	psi
Allowable tensile strain	eps mT	0.810E-01	in/in
Allowable compr. strain	eps mC	0.150E+00	in/in
Allowable shear strain	eps mS	0.100E+00	in/in
Allowable torsional strain	eps mTOR	0.100E+00	in/in
Void heat conductivity	kv	0.225E+00	BTU-in/hr/in**2/F
Glass transition temperature	Tgdr	0.250E+03	F

ADHX EQUIVALENT MATRIX PROPS. FOR ADHESIVE.

Weight density	Rhom	0.400E-01	lb/in**3
Normal modulus	Em	0.300E+06	psi
Poisson"s ratio	Num	0.450E+00	non-dim

Thermal expansion coef.	Alfa m	0.570E-04	in/in/F
Matrix heat conductivity	Km	0.125E+01	BTU-in/hr/in**2/F
Heat capacity	Cm	0.250E+00	BTU/lb/F
Matrix tensile strength	SmT	0.800E+04	psi
Matrix compressive strength	SmC	0.150E+05	psi
Matrix shear strength	SmS	0.800E+04	psi
Allowable tensile strain	eps mT	0.810E-01	in/in
Allowable compr. strain	eps mC	0.150E+00	in/in
Allowable shear strain	eps mS	0.100E+00	in/in
Allowable torsional strain	eps mTOR	0.100E+00	in/in
Void heat conductivity	kv	0.225E+00	BTU-in/hr/in**2/F
Glass transition temperature	Tgdr	0.350E+03	F

HALM

Weight density	Rhom	0.815E-03	lb/in**3
Normal modulus	Em	0.890E+05	psi
Poisson"s ratio	Num	0.300E+00	non-dim
Thermal expansion coef.	Alfa m	0.126E-04	in/in/F
Matrix heat conductivity	Km	0.259E-01	BTU-in/hr/in**2/F
Heat capacity	Cm	0.220E+00	BTU/lb/F
Matrix tensile strength	SmT	0.800E+04	psi
Matrix compressive strength	SmC	0.150E+05	psi
Matrix shear strength	SmS	0.800E+04	psi
Allowable tensile strain	eps mT	0.810E-01	in/in
Allowable compr. strain	eps mC	0.150E+00	in/in
Allowable shear strain	eps mS	0.100E+00	in/in
Allowable torsional strain	eps mTOR	0.100E+00	in/in
Void heat conductivity	kv	0.225E+00	BTU-in/hr/in**2/F
Glass transition temperature	Tgdr	0.120E+04	F

ALT6 ALUMINUM MATRIX. DEC 16, 1987.

		(1)	
Weight density	Rhom	0.980E-01	lb/in**3
Normal modulus	Em	0.100E+08	psi
Poisson"s ratio	Num	0.300E+00	non-dim
Thermal expansion coef.	Alfa m	0.131E-04	in/in/F
Matrix heat conductivity	Km	0.866E+01	BTU-in/hr/in**2/F
Heat capacity	Cm	0.230E+00	BTU/lb/F
Matrix tensile strength	SmT	0.180E+05	psi
Matrix compressive strength	SmC	0.180E+05	psi
Matrix shear strength	SmS	0.120E+05	psi
Allowable tensile strain	eps mT	0.300E+00	in/in
Allowable compr. strain	eps mC	0.300E+00	in/in
Allowable shear strain	eps mS	0.300E+00	in/in
Allowable torsional strain	eps mTOR	0.300E+00	in/in
Void heat conductivity	kv	0.190E-01	BTU-in/hr/in**2/F
Glass transition temperature	Tgdr	0.108E+04	F

R934 SIMULATION OF 934 RESIN

Weight density	Rhom	0.470E-01	lb/in**3
Normal modulus	Em	0.560E+06	psi
Poisson"s ratio	Num	0.350E+00	non-dim
Thermal expansion coef.	Alfa m	0.360E-04	in/in/F
MATRIX HEAT CONDUCTIVITY	KM	0.104E+00	BTU-IN/HR/IN**2/F
Heat capacity	Cm	0.250E+00	BTU/lb/F
Matrix tensile strength	SmT	0.710E+04	psi
Matrix compressive strength	SmC	0.350E+05	psi
Matrix shear strength	SmS	0.500E+04	psi
Allowable tensile strain	eps mT	0.200E-01	in/in
Allowable compr. strain	eps mC	0.500E-01	in/in
Allowable shear strain	eps mS	0.350E-01	in/in
Allowable torsional strain	eps mTOR	0.350E-01	in/in
Void heat conductivity	kv	0.225E+00	BTU-in/hr/in**2/F
Glass transition temperature	Tgdr	0.392E+03	F

XXXX F185 NEAT RESIN CASTING. SEPT. 7, 1984.

Weight density	Rhom	0.443E-01	lb/in**3
Normal modulus	Em	0.400E+06	psi
Poisson"s ratio	Num	0.450E+00	non-dim
Thermal expansion coef.	Alfa m	0.570E-04	in/in/F
MATRIX HEAT CONDUCTIVITY	KM	0.104E+00	BTU-IN/HR/IN**2/F
Heat capacity	Cm	0.250E+00	BTU/lb/F
Matrix tensile strength	SmT	0.650E+04	psi
Matrix compressive strength	SmC	0.210E+05	psi
Matrix shear strength	SmS	0.650E+04	psi
Allowable tensile strain	eps mT	0.140E-01	in/in
Allowable compr. strain	eps mC	0.420E-01	in/in
Allowable shear strain	eps mS	0.320E-01	in/in
Allowable torsional strain	eps mTOR	0.380E-01	in/in
Void heat conductivity	kv	0.225E+00	BTU-in/hr/in**2/F
Glass transition temperature	Tgdr	0.420E+03	F

F185 NEAT RESIN CASTING. SEPT. 7, 1984.

Weight density	Rhom	0.443E-01	lb/in**3
Normal modulus	Em	0.491E+08	psi
Poisson"s ratio	Num	0.300E+00	non-dim
Thermal expansion coef.	Alfa m	0.219E-05	in/in/F
MATRIX HEAT CONDUCTIVITY	KM	0.104E+00	BTU-IN/HR/IN**2/F
Heat capacity	Cm	0.250E+00	BTU/lb/F
Matrix tensile strength	SmT	0.650E+04	psi
Matrix compressive strength	SmC	0.210E+05	psi
Matrix shear strength	SmS	0.650E+04	psi
Allowable tensile strain	eps mT	0.140E-01	in/in
Allowable compr. strain	eps mC	0.420E-01	in/in
Allowable shear strain	eps mS	0.320E-01	in/in
Allowable torsional strain	eps mTOR	0.380E-01	in/in
Void heat conductivity	kv	0.225E+00	BTU-in/hr/in**2/F
Glass transition temperature	Tgdr	0.420E+03	F

F186 NEAT RESIN CASTING. SEPT. 7, 1984.

Weight density	Rhom	0.443E-01	lb/in**3
Normal modulus	Em	0.243E+08	psi
Poisson"s ratio	Num	0.300E+00	non-dim
Thermal expansion coef.	Alfa m	0.345E-05	in/in/F
MATRIX HEAT CONDUCTIVITY	KM	0.104E+00	BTU-IN/HR/IN**2/F
Heat capacity	Cm	0.250E+00	BTU/lb/F
Matrix tensile strength	SmT	0.650E+04	psi
Matrix compressive strength	SmC	0.210E+05	psi
Matrix shear strength	SmS	0.650E+04	psi
Allowable tensile strain	eps mT	0.140E-01	in/in
Allowable compr. strain	eps mC	0.420E-01	in/in
Allowable shear strain	eps mS	0.320E-01	in/in
Allowable torsional strain	eps mTOR	0.380E-01	in/in
Void heat conductivity	kv	0.225E+00	BTU-in/hr/in**2/F
Glass transition temperature	Tgdr	0.420E+03	F

SPOX IMHS INTERMEDIATE MODULUS HIGH STRENGTH MATRIX.

Weight density	Rhom	0.443E-01	lb/in**3
Normal modulus	Em	0.500E+06	psi
Poisson"s ratio	Num	0.410E+00	non-dim
Thermal expansion coef.	Alfa m	0.570E-04	in/in/F
MATRIX HEAT CONDUCTIVITY	KM	0.104E+00	BTU-IN/HR/IN**2/F
Heat capacity	Cm	0.250E+00	BTU/lb/F
Matrix tensile strength	SmT	0.150E+05	psi
Matrix compressive strength	SmC	0.300E+05	psi
Matrix shear strength	SmS	0.150E+05	psi
Allowable tensile strain	eps mT	0.140E-01	in/in
Allowable compr. strain	eps mC	0.420E-01	in/in
Allowable shear strain	eps mS	0.320E-01	in/in

Allowable torsional strain	eps mTOR	0.380E-01	in/in
Void heat conductivity	kv	0.225E+00	BTU-in/hr/in**2/F
Glass transition temperature	Tgdr	0.420E+03	F

GK60 IMLS INTERMEDIATE MODULUS LOW STRENGTH MATRIX.

Weight density	Rhom	0.460E-01	lb/in**3
Normal modulus	Em	0.500E+06	psi
Poisson"s ratio	Num	0.410E+00	non-dim
Thermal expansion coef.	Alfa m	0.570E-04	in/in/F
MATRIX HEAT CONDUCTIVITY	KM	0.104E+00	BTU-IN/HR/IN**2/F
Heat capacity	Cm	0.250E+00	BTU/lb/F
Matrix tensile strength	SmT	0.700E+04	psi
Matrix compressive strength	SmC	0.210E+05	psi
Matrix shear strength	SmS	0.700E+04	psi
Allowable tensile strain	eps mT	0.140E-01	in/in
Allowable compr. strain	eps mC	0.420E-01	in/in
Allowable shear strain	eps mS	0.320E-01	in/in
Allowable torsional strain	eps mTOR	0.380E-01	in/in
Void heat conductivity	kv	0.225E+00	BTU-in/hr/in**2/F
Glass transition temperature	Tgdr	0.420E+03	F

EPOX IMHS INTERMEDIATE MODULUS HIGH STRENGTH MATRIX.

Weight density	Rhom	0.443E-01	lb/in**3
Normal modulus	Em	0.500E+06	psi
Poisson"s ratio	Num	0.350E+00	non-dim
Thermal expansion coef.	Alfa m	0.428E-04	in/in/F
MATRIX HEAT CONDUCTIVITY	KM	0.104E+00	BTU-IN/HR/IN**2/F
Heat capacity	Cm	0.250E+00	BTU/lb/F
Matrix tensile strength	SmT	0.150E+05	psi
Matrix compressive strength	SmC	0.350E+05	psi
Matrix shear strength	SmS	0.130E+05	psi
Allowable tensile strain	eps mT	0.200E-01	in/in
Allowable compr. strain	eps mC	0.500E-01	in/in
Allowable shear strain	eps mS	0.450E-01	in/in
Allowable torsional strain	eps mTOR	0.450E-01	in/in
Void heat conductivity	kv	0.225E+00	BTU-in/hr/in**2/F
Glass transition temperature	Tgdr	0.420E+03	F

ERLA HMHS HIGH MODULUS HIGH STRENGTH MATRIX.

Weight density	Rhom	0.450E-01	lb/in**3
Normal modulus	Em	0.750E+06	psi
Poisson"s ratio	Num	0.350E+00	non-dim
Thermal expansion coef.	Alfa m	0.400E-04	in/in/F
Matrix heat conductivity	Km	0.104E+00	BTU-in/hr/in**2/F
Heat capacity	Cm	0.250E+00	BTU/lb/F
Matrix tensile strength	SmT	0.200E+05	psi
Matrix compressive strength	SmC	0.500E+05	psi
Matrix shear strength	SmS	0.150E+05	psi
Allowable tensile strain	eps mT	0.200E-01	in/in
Allowable compr. strain	eps mC	0.500E-01	in/in
Allowable shear strain	eps mS	0.400E-01	in/in
Allowable torsional strain	eps mTOR	0.400E-01	in/in
Void heat conductivity	kv	0.225E+00	BTU-in/hr/in**2/F
Glass transition temperature	Tgdr	0.420E+03	F

POLY POLYIMIDE MATRIX.

Weight density	Rhom	0.440E-01	lb/in**3
Normal modulus	Em	0.500E+06	psi
Poisson"s ratio	Num	0.350E+00	non-dim
Thermal expansion coef.	Alfa m	0.200E-04	in/in/F
Matrix heat conductivity	Km	0.146E+00	BTU-in/hr/in**2/F
Heat capacity	Cm	0.250E+00	BTU/lb/F
Matrix tensile strength	SmT	0.150E+05	psi
Matrix compressive strength	SmC	0.300E+05	psi

Matrix shear strength	SmS	0.130E+05	psi
Allowable tensile strain	eps mT	0.200E-01	in/in
Allowable compr. strain	eps mC	0.400E-01	in/in
Allowable shear strain	eps mS	0.350E-01	in/in
Allowable torsional strain	eps mTOR	0.350E-01	in/in
Void heat conductivity	kv	0.225E+00	BTU-in/hr/in**2/F
Glass transition temperature	Tgdr	0.700E+03	F

ALTX ALUMINUM MATRIX.

Weight density	Rhom	0.950E-01	lb/in**3
Normal modulus	Em	0.100E+08	psi
Poisson"s ratio	Num	0.330E+00	non-dim
Thermal expansion coef.	Alfa m	0.129E-04	in/in/F
Matrix heat conductivity	Km	0.866E+01	BTU-in/hr/in**2/F
Heat capacity	Cm	0.230E+00	BTU/lb/F
Matrix tensile strength	SmT	0.520E+05	psi
Matrix compressive strength	SmC	0.520E+05	psi
Matrix shear strength	SmS	0.260E+05	psi
Allowable tensile strain	eps mT	0.520E-02	in/in
Allowable compr. strain	eps mC	0.520E-02	in/in
Allowable shear strain	eps mS	0.905E-02	in/in
Allowable torsional strain	eps mTOR	0.905E-02	in/in
Void heat conductivity	kv	0.225E+00	BTU-in/hr/in**2/F
Glass transition temperature	Tgdr	0.108E+04	F

TIT6 TITANIUM MATRIX.

Weight density	Rhom	0.161E+00	lb/in**3
Normal modulus	Em	0.165E+08	psi
Poisson"s ratio	Num	0.300E+00	non-dim
Thermal expansion coef.	Alfa m	0.570E-05	in/in/F
Matrix heat conductivity	Km	0.100E+01	BTU-in/hr/in**2/F
Heat capacity	Cm	0.127E+00	BTU/lb/F
Matrix tensile strength	SmT	0.120E+06	psi
Matrix compressive strength	SmC	0.120E+06	psi
Matrix shear strength	SmS	0.800E+05	psi
Allowable tensile strain	eps mT	0.730E-02	in/in
Allowable compr. strain	eps mC	0.730E-02	in/in
Allowable shear strain	eps mS	0.124E-01	in/in
Allowable torsional strain	eps mTOR	0.124E-01	in/in
Void heat conductivity	kv	0.225E+00	BTU-in/hr/in**2/F
Glass transition temperature	Tgdr	0.150E+04	F

TITX TITANIUM MATRIX.

Weight density	Rhom	0.161E+00	lb/in**3
Normal modulus	Em	0.130E+08	psi
Poisson"s ratio	Num	0.360E+00	non-dim
Thermal expansion coef.	Alfa m	0.540E-05	in/in/F
Matrix heat conductivity	Km	0.100E+01	BTU-in/hr/in**2/F
Heat capacity	Cm	0.127E+00	BTU/lb/F
Matrix tensile strength	SmT	0.120E+06	psi
Matrix compressive strength	SmC	0.120E+06	psi
Matrix shear strength	SmS	0.800E+05	psi
Allowable tensile strain	eps mT	0.730E-02	in/in
Allowable compr. strain	eps mC	0.730E-02	in/in
Allowable shear strain	eps mS	0.124E-01	in/in
Allowable torsional strain	eps mTOR	0.124E-01	in/in
Void heat conductivity	kv	0.225E+00	BTU-in/hr/in**2/F
Glass transition temperature	Tgdr	0.185E+04	F

EPOC EPOXY MATRIX.

Weight density	Rhom	0.440E-01	lb/in**3
Normal modulus	Em	0.500E+06	psi
Poisson"s ratio	Num	0.350E+00	non-dim
Thermal expansion coef.	Alfa m	0.360E-04	in/in/F

Matrix heat conductivity	Km	0.146E+00	BTU-in/hr/in**2/F
Heat capacity	Cm	0.250E+00	BTU/lb/F
Matrix tensile strength	SmT	0.150E+05	psi
Matrix compressive strength	SmC	0.250E+05	psi
Matrix shear strength	SmS	0.130E+05	psi
Allowable tensile strain	eps mT	0.200E-02	in/in
Allowable compr. strain	eps mC	0.500E-02	in/in
Allowable shear strain	eps mS	0.350E-02	in/in
Allowable torsional strain	eps mTOR	0.350E-02	in/in
Void heat conductivity	kv	0.225E+00	BTU-in/hr/in**2/F
Glass transition temperature	Tgdr	0.410E+03	F

SSAL STAINLESS STEEL MATRIX.

Weight density	Rhom	0.281E+00	lb/in**3
Normal modulus	Em	0.289E+08	psi
Poisson"s ratio	Num	0.300E+00	non-dim
Thermal expansion coef.	Alfa m	0.570E-05	in/in/F
Matrix heat conductivity	Km	0.158E+01	BTU-in/hr/in**2/F
Heat capacity	Cm	0.120E+00	BTU/lb/F
Matrix tensile strength	SmT	0.160E+06	psi
Matrix compressive strength	SmC	0.160E+06	psi
Matrix shear strength	SmS	0.120E+06	psi
Allowable tensile strain	eps mT	0.550E-02	in/in
Allowable compr. strain	eps mC	0.550E-02	in/in
Allowable shear strain	eps mS	0.104E-01	in/in
Allowable torsional strain	eps mTOR	0.104E-01	in/in
Void heat conductivity	kv	0.225E+00	BTU-in/hr/in**2/F
Glass transition temperature	Tgdr	0.266E+04	F

GV60

Weight density	Rhom	0.460E-01	lb/in**3
Normal modulus	Em	0.100E+04	psi
Poisson"s ratio	Num	0.410E+00	non-dim
Thermal expansion coef.	Alfa m	0.570E-04	in/in/F
Matrix heat conductivity	Km	0.104E+00	BTU-in/hr/in**2/F
Heat capacity	Cm	0.250E+00	BTU/lb/F
Matrix tensile strength	SmT	0.700E+04	psi
Matrix compressive strength	SmC	0.210E+05	psi
Matrix shear strength	SmS	0.700E+04	psi
Allowable tensile strain	eps mT	0.140E-01	in/in
Allowable compr. strain	eps mC	0.420E-01	in/in
Allowable shear strain	eps mS	0.320E-01	in/in
Allowable torsional strain	eps mTOR	0.380E-01	in/in
Void heat conductivity	kv	0.225E+00	BTU-in/hr/in**2/F
Glass transition temperature	Tgdr	0.410E+03	F

PMRP PMR POLYIMIDE MATRIX.

Weight density	Rhom	0.440E-01	lb/in**3
Normal modulus	Em	0.470E+06	psi
Poisson"s ratio	Num	0.360E+00	non-dim
Thermal expansion coef.	Alfa m	0.280E-04	in/in/F
Matrix heat conductivity	Km	0.146E+00	BTU-in/hr/in**2/F
Heat capacity	Cm	0.250E+00	BTU/lb/F
Matrix tensile strength	SmT	0.810E+04	psi
Matrix compressive strength	SmC	0.165E+05	psi
Matrix shear strength	SmS	0.810E+04	psi
Allowable tensile strain	eps mT	0.183E-01	in/in
Allowable compr. strain	eps mC	0.350E-01	in/in
Allowable shear strain	eps mS	0.500E-01	in/in
Allowable torsional strain	eps mTOR	0.500E-01	in/in
Void heat conductivity	kv	0.225E+00	BTU-in/hr/in**2/F
Glass transition temperature	Tgdr	0.700E+03	F

PM15 PMR POLYIMIDE MATRIX.

Weight density	Rhom	0.440E-01	lb/in**3
Normal modulus	Em	0.470E+06	psi
Poisson"s ratio	Num	0.360E+00	non-dim
Thermal expansion coef.	Alfa m	0.280E-04	in/in/F
Matrix heat conductivity	Km	0.146E+00	BTU-in/hr/in**2/F
Heat capacity	Cm	0.250E+00	BTU/lb/F
Matrix tensile strength	SmT	0.810E+04	psi
Matrix compressive strength	SmC	0.165E+05	psi
Matrix shear strength	SmS	0.810E+04	psi
Allowable tensile strain	eps mT	0.183E-01	in/in
Allowable compr. strain	eps mC	0.350E-01	in/in
Allowable shear strain	eps mS	0.500E-01	in/in
Allowable torsional strain	eps mTOR	0.500E-01	in/in
Void heat conductivity	kv	0.225E+00	BTU-in/hr/in**2/F
Glass transition temperature	Tgdr	0.600E+03	F

BERY BERYLLIUM MATRIX.

Weight density	Rhom	0.570E-01	lb/in**3
Normal modulus	Em	0.440E+08	psi
Poisson"s ratio	Num	0.100E+00	non-dim
Thermal expansion coef.	Alfa m	0.640E-05	in/in/F
Matrix heat conductivity	Km	0.968E+01	BTU-in/hr/in**2/F
Heat capacity	Cm	0.450E+00	BTU/lb/F
Matrix tensile strength	SmT	0.133E+06	psi
Matrix compressive strength	SmC	0.133E+06	psi
Matrix shear strength	SmS	0.770E+05	psi
Allowable tensile strain	eps mT	0.302E-02	in/in
Allowable compr. strain	eps mC	0.302E-02	in/in
Allowable shear strain	eps mS	0.385E-02	in/in
Allowable torsional strain	eps mTOR	0.385E-02	in/in
Void heat conductivity	kv	0.225E+00	BTU-in/hr/in**2/F
Glass transition temperature	Tgdr	0.234E+04	F

NM40

Weight density	Rhom	0.320E+00	lb/in**3
Normal modulus	Em	0.260E+08	psi
Poisson"s ratio	Num	0.300E+00	non-dim
Thermal expansion coef.	Alfa m	0.770E-05	in/in/F
Matrix heat conductivity	Km	0.126E+02	BTU-in/hr/in**2/F
Heat capacity	Cm	0.102E+00	BTU/lb/F
Matrix tensile strength	SmT	0.250E+05	psi
Matrix compressive strength	SmC	0.250E+05	psi
Matrix shear strength	SmS	0.144E+05	psi
Allowable tensile strain	eps mT	0.960E-03	in/in
Allowable compr. strain	eps mC	0.960E-03	in/in
Allowable shear strain	eps mS	0.144E-02	in/in
Allowable torsional strain	eps mTOR	0.144E-02	in/in
Void heat conductivity	kv	0.225E+00	BTU-in/hr/in**2/F
Glass transition temperature	Tgdr	0.410E+03	F

FMTH FM1000 ADHESIVE MATRIX.

Weight density	Rhom	0.420E-01	lb/in**3
Normal modulus	Em	0.210E+06	psi
Poisson"s ratio	Num	0.400E+00	non-dim
Thermal expansion coef.	Alfa m	0.400E-04	in/in/F
Matrix heat conductivity	Km	0.104E+00	BTU-in/hr/in**2/F
Heat capacity	Cm	0.260E+00	BTU/lb/F
Matrix tensile strength	SmT	0.600E+04	psi
Matrix compressive strength	SmC	0.100E+05	psi
Matrix shear strength	SmS	0.600E+04	psi
Allowable tensile strain	eps mT	0.286E-01	in/in
Allowable compr. strain	eps mC	0.476E+00	in/in
Allowable shear strain	eps mS	0.800E-01	in/in
Allowable torsional strain	eps mTOR	0.800E-01	in/in

Void heat conductivity	kv	0.225E+00	BTU-in/hr/in**2/F
Glass transition temperature	Tgdr	0.410E+03	F

LMLS LOW MODULUS LOW STRENGTH MATRIX.

Weight density	Rhom	0.420E-01	lb/in**3
Normal modulus	Em	0.320E+06	psi
Poisson"s ratio	Num	0.430E+00	non-dim
Thermal expansion coef.	Alfa m	0.570E-04	in/in/F
Matrix heat conductivity	Km	0.104E+00	BTU-in/hr/in**2/F
Heat capacity	Cm	0.250E+00	BTU/lb/F
Matrix tensile strength	SmT	0.800E+04	psi
Matrix compressive strength	SmC	0.150E+05	psi
Matrix shear strength	SmS	0.800E+04	psi
Allowable tensile strain	eps mT	0.810E-01	in/in
Allowable compr. strain	eps mC	0.150E+00	in/in
Allowable shear strain	eps mS	0.100E+00	in/in
Allowable torsional strain	eps mTOR	0.100E+00	in/in
Void heat conductivity	kv	0.225E+00	BTU-in/hr/in**2/F
Glass transition temperature	Tgdr	0.350E+03	F

IMLS INTERMEDIATE MODULUS LOW STRENGTH MATRIX.

Weight density	Rhom	0.460E-01	lb/in**3
Normal modulus	Em	0.500E+06	psi
Poisson"s ratio	Num	0.410E+00	non-dim
Thermal expansion coef.	Alfa m	0.570E-04	in/in/F
Matrix heat conductivity	Km	0.104E+00	BTU-in/hr/in**2/F
Heat capacity	Cm	0.250E+00	BTU/lb/F
Matrix tensile strength	SmT	0.700E+04	psi
Matrix compressive strength	SmC	0.210E+05	psi
Matrix shear strength	SmS	0.700E+04	psi
Allowable tensile strain	eps mT	0.140E-01	in/in
Allowable compr. strain	eps mC	0.420E-01	in/in
Allowable shear strain	eps mS	0.320E-01	in/in
Allowable torsional strain	eps mTOR	0.320E-01	in/in
Void heat conductivity	kv	0.225E+00	BTU-in/hr/in**2/F
Glass transition temperature	Tgdr	0.420E+03	F

IMHS INTERMEDIATE MODULUS HIGH STRENGTH MATRIX.

Weight density	Rhom	0.440E-01	lb/in**3
Normal modulus	Em	0.500E+06	psi
Poisson"s ratio	Num	0.350E+00	non-dim
Thermal expansion coef.	Alfa m	0.360E-04	in/in/F
Matrix heat conductivity	Km	0.104E+00	BTU-in/hr/in**2/F
Heat capacity	Cm	0.250E+00	BTU/lb/F
Matrix tensile strength	SmT	0.150E+05	psi
Matrix compressive strength	SmC	0.350E+05	psi
Matrix shear strength	SmS	0.130E+05	psi
Allowable tensile strain	eps mT	0.200E-01	in/in
Allowable compr. strain	eps mC	0.500E-01	in/in
Allowable shear strain	eps mS	0.350E-01	in/in
Allowable torsional strain	eps mTOR	0.350E-01	in/in
Void heat conductivity	kv	0.225E+00	BTU-in/hr/in**2/F
Glass transition temperature	Tgdr	0.420E+03	F

HMHS HIGH MODULUS HIGH STRENGTH MATRIX.

Weight density	Rhom	0.450E-01	lb/in**3
Normal modulus	Em	0.750E+06	psi
Poisson"s ratio	Num	0.350E+00	non-dim
Thermal expansion coef.	Alfa m	0.400E-04	in/in/F
Matrix heat conductivity	Km	0.104E+00	BTU-in/hr/in**2/F
Heat capacity	Cm	0.250E+00	BTU/lb/F
Matrix tensile strength	SmT	0.200E+05	psi
Matrix compressive strength	SmC	0.500E+05	psi
Matrix shear strength	SmS	0.150E+05	psi

Allowable tensile strain	eps mT	0.200E-01	in/in
Allowable compr. strain	eps mC	0.500E-01	in/in
Allowable shear strain	eps mS	0.400E-01	in/in
Allowable torsional strain	eps mTOR	0.400E-01	in/in
Void heat conductivity	kv	0.225E+00	BTU-in/hr/in**2/F
Glass transition temperature	Tgdr	0.420E+03	F

MAGN MAGNESIUM -- METAL MATRIX.AZ31B-H24

Weight density	Rhom	0.600E-01	lb/in**3
Normal modulus	Em	0.600E+07	psi
Poisson"s ratio	Num	0.300E+00	non-dim
Thermal expansion coef.	Alfa m	0.140E-04	in/in/F
Matrix heat conductivity	Km	0.667E+01	BTU-in/hr/in**2/F
Heat capacity	Cm	0.240E+00	BTU/lb/F
Matrix tensile strength	SmT	0.400E+05	psi
Matrix compressive strength	SmC	0.400E+05	psi
Matrix shear strength	SmS	0.250E+05	psi
Allowable tensile strain	eps mT	0.200E-01	in/in
Allowable compr. strain	eps mC	0.500E-01	in/in
Allowable shear strain	eps mS	0.400E-01	in/in
Allowable torsional strain	eps mTOR	0.400E-01	in/in
Void heat conductivity	kv	0.225E+00	BTU-in/hr/in**2/F
Glass transition temperature	Tgdr	0.105E+04	F

FECR SUPERALLOY (FE-25%CR-4%AL-1%Y) MATRIX

Weight density	Rhom	0.260E+00	lb/in**3
Normal modulus	Em	0.302E+08	psi
Poisson"s ratio	Num	0.300E+00	non-dim
Thermal expansion coef.	Alfa m	0.528E-05	in/in/F
Matrix heat conductivity	Km	0.125E+01	BTU-in/hr/in**2/F
Heat capacity	Cm	0.112E+00	BTU/lb/F
Matrix tensile strength	SmT	0.110E+06	psi
Matrix compressive strength	SmC	0.110E+06	psi
Matrix shear strength	SmS	0.660E+05	psi
Allowable tensile strain	eps mT	0.256E-02	in/in
Allowable compr. strain	eps mC	0.256E-02	in/in
Allowable shear strain	eps mS	0.154E-02	in/in
Allowable torsional strain	eps mTOR	0.154E-02	in/in
Void heat conductivity	kv	0.225E+00	BTU-in/hr/in**2/F
Glass transition temperature	Tgdr	0.105E+04	F

R930 SIMULATION OF 930 RESIN JULY 6,1990.

Weight density	Rhom	0.400E-01	lb/in**3
Normal modulus	Em	0.300E+06	psi
Poisson"s ratio	Num	0.450E+00	non-dim
Thermal expansion coef.	Alfa m	0.360E-04	in/in/F
Matrix heat conductivity	Km	0.104E+00	BTU-in/hr/in**2/F
Heat capacity	Cm	0.250E+00	BTU/lb/F
Matrix tensile strength	SmT	0.710E+04	psi
Matrix compressive strength	SmC	0.140E+05	psi
Matrix shear strength	SmS	0.710E+04	psi
Allowable tensile strain	eps mT	0.200E-01	in/in
Allowable compr. strain	eps mC	0.500E-01	in/in
Allowable shear strain	eps mS	0.350E-01	in/in
Allowable torsional strain	eps mTOR	0.350E-01	in/in
Void heat conductivity	kv	0.225E+00	BTU-in/hr/in**2/F
Glass transition temperature	Tgdr	0.220E+03	F

OVER END OF MATRIX PROPERTIES

INDEX

- Airfoil Coordinates, 2.2-2.6, 2.16-2.18
- Aset Data, 2.49

- Blade, composite, 2.23, 2.39-2.41
 - cross-section offsets, 2.42
 - hollow, 2.23, 2.37-2.38,
 - solid, 2.23
 - superhybrid, 2.23, 2.39
- BLASIM, 1.1-1.3,2.1-2.4,2.9-2.11,3.1-3.4,3.7-3.11,A.3
- Boundary conditions, 2.46-2.49

- Coordinates, Airfoil, 2.1-2.2, 2.16-2.18
 - NASTRAN, 2.1, 2.19
 - type, 2.13

- Failure criterion,
 - Modified Distortion Energy (MDE), 2.24
 - Hoffman, 2.24
- Fatigue, life data, 2.51-2.59
 - Goodman diagram, 2.25
 - forcing function, 2.24,2.60
- Finite element grid, 2.13, 2.19
- Flutter, 2.23,2.28-2.29,A.1,A.10,,A.14
- Foreign Object Damage (FOD),
 - local, 2.23-2.24,2.31
 - root, 2.23-2.24
- Frequency correction factors, 2.26

- ICAN, B.1-B.24

- Ice impact, input description, 2.32
 - option for analysis, 2.24
- Input, NASTRAN file, 2.1
 - generation, 2.1-2.7,A.1-A.5
 - listing, 2.7-2.9,A.6-A.8

- Mach number, 2.29
- Material properties, 2.35
- Modal analysis, A.15-A.21

- Output, 2.1
 - listing, 2.9,A.8-A.14

- Pressure data, 2.50-2.51

- Resonance margin, 2.24

REPORT DOCUMENTATION PAGEForm Approved
OMB No. 0704-0188

Public reporting burden for this collection of information is estimated to average 1 hour per response, including the time for reviewing instructions, searching existing data sources, gathering and maintaining the data needed, and completing and reviewing the collection of information. Send comments regarding this burden estimate or any other aspect of this collection of information, including suggestions for reducing this burden, to Washington Headquarters Services, Directorate for Information Operations and Reports, 1215 Jefferson Davis Highway, Suite 1204, Arlington, VA 22202-4302, and to the Office of Management and Budget, Paperwork Reduction Project (0704-0188), Washington, DC 20503.

1. AGENCY USE ONLY (Leave blank)		2. REPORT DATE April 1993	3. REPORT TYPE AND DATES COVERED Final Contractor Report	
4. TITLE AND SUBTITLE Blade Assessment Ice Impact (BLASIM) User's Manual, Version 1.0			5. FUNDING NUMBERS WU-505-62-OK C-NAS3-25266	
6. AUTHOR(S) E.S. Reddy and G.H. Abumeri				
7. PERFORMING ORGANIZATION NAME(S) AND ADDRESS(ES) Sverdrup Technology, Inc. Lewis Research Center Group 2001 Aerospace Parkway Brook Park, Ohio 44142			8. PERFORMING ORGANIZATION REPORT NUMBER E-7733	
9. SPONSORING/MONITORING AGENCY NAMES(S) AND ADDRESS(ES) National Aeronautics and Space Administration Lewis Research Center Cleveland, Ohio 44135-3191			10. SPONSORING/MONITORING AGENCY REPORT NUMBER NASA CR-191075	
11. SUPPLEMENTARY NOTES Project Manager, P.L.N. Murthy, Structures Division, (216) 433-3332.				
12a. DISTRIBUTION/AVAILABILITY STATEMENT Unclassified - Unlimited Subject Category 39			12b. DISTRIBUTION CODE	
13. ABSTRACT (Maximum 200 words) The BLASIM computer code can analyze solid, hollow, composite and superhybrid blades. The solid blade is made up of a single material where hollow, composite and superhybrid blades are constructed with prescribed composite layup. The properties of a composite blade can be specified by inputting one of two options: (1) individual ply properties, or (2) fiber/matrix combinations. When the second option is selected, BLASIM utilizes ICAN (Integrated Composite ANalyzer) to generate the temperature/moisture dependent ply properties of the composite blade. Two types of geometry input can be given: airfoil coordinates or NASTRAN type finite element model. These features increase the flexibility of the program. The user's manual provides sample cases to facilitate efficient use of the code while gaining familiarity.				
14. SUBJECT TERMS Composite; Hybrid; Superhybrid; Solid blades; Hollow blades; Fibers; Matrix temperature; Moisture; Finite element; Interactive; Batch			15. NUMBER OF PAGES 128	
			16. PRICE CODE A07	
17. SECURITY CLASSIFICATION OF REPORT Unclassified	18. SECURITY CLASSIFICATION OF THIS PAGE Unclassified	19. SECURITY CLASSIFICATION OF ABSTRACT Unclassified	20. LIMITATION OF ABSTRACT	