

**ORBIT DETERMINATION AND ORBIT CONTROL  
FOR THE EARTH OBSERVING SYSTEM (EOS) AM SPACECRAFT**

**Joseph R. Herberg  
General Electric Astro-Space Division**

**David C. Folta  
Flight Dynamics Analysis Branch  
Goddard Space Flight Center**

**N 98-24705**

154731

1. 16

**ABSTRACT**

Future NASA Earth Observing System (EOS) Spacecraft will make measurements of the earth's clouds, oceans, atmosphere, land and radiation balance. These EOS Spacecraft will be part of the NASA Mission to Planet Earth. This paper specifically addresses the EOS AM Spacecraft, referred to as "AM" because it has a sun-synchronous orbit with a 10:30 AM descending node. This paper describes the EOS AM Spacecraft mission orbit requirements, orbit determination, orbit control, and navigation system impact on earth based pointing. The EOS AM Spacecraft will be the first spacecraft to use the TDRSS Onboard Navigation System (TONS) as the primary means of navigation. TONS flight software will process one-way forward Doppler measurements taken during scheduled TDRSS contacts. An extended Kalman filter will estimate spacecraft position, velocity, drag coefficient correction, and ultrastable master oscillator frequency bias and drift. The TONS baseline algorithms, software, and hardware implementation are described in this paper. TONS integration into the EOS AM Spacecraft Guidance, Navigation and Control (GN&C) System, TONS assisted onboard time maintenance, and the TONS Ground Support System (TGSS) are also addressed.

---

This work was performed for the National Aeronautics and Space Administration (NASA) Goddard Space Flight Center (GSFC), Greenbelt, MD, under contract NAS5-32500.

## 1.0 INTRODUCTION AND BACKGROUND

Future NASA Earth Observing System (EOS) Spacecraft will make measurements of the earth's clouds, oceans, atmosphere, land and radiation balance. These EOS Spacecraft will be part of the NASA Mission to Planet Earth. This paper specifically addresses the EOS AM Spacecraft, referred to as "AM" because it has a sun-synchronous orbit with a 10:30 AM descending node. The EOS AM Spacecraft is shown in Figure 1. The first EOS AM Spacecraft is scheduled for launch in 1998. A second and third EOS AM Spacecraft will subsequently be launched in five year intervals. The five year mission life for each EOS AM Spacecraft will yield 15 years of continuous scientific observations. Normal command, telemetry, and primary science data return will be through the Tracking and Data Relay Satellite System (TDRSS). Additionally, a direct downlink capability will be provided to send science data directly to user ground stations.

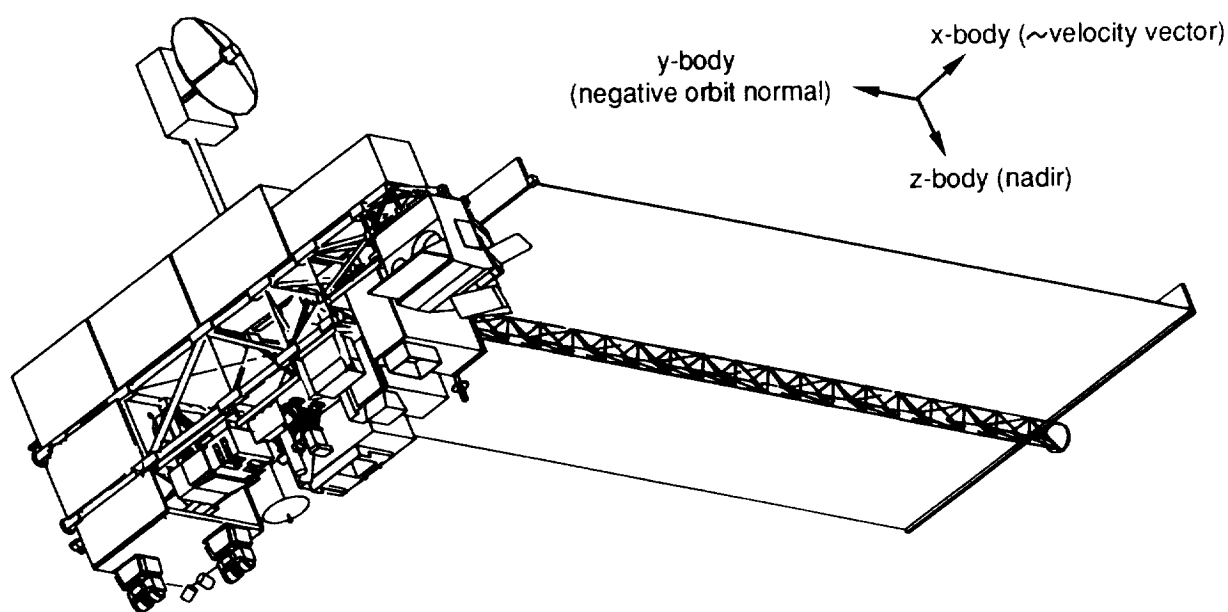

**Figure 1 : EOS AM Spacecraft**

Table 1 lists the EOS AM Spacecraft mission requirements that are related to orbit determination and orbit control. These requirements were derived from and are driven by instrument science requirements (Reference 1). Requirements include earth pointing knowledge and control, earth pointing jitter and stability, and navigation. Additional effort is in process to refine jitter and stability requirements, and to refine estimates of spacecraft performance with respect to jitter and stability. Jitter as used here refers to peak-to-peak spacecraft attitude motion over time periods required to image one pixel. Stability as used here refers to peak-to-peak spacecraft attitude motion over time periods required to image one scene composed of many pixels. The location of a pixel or scene on the surface of the earth is referred to as the geolocation. Navigation as used here refers to real-time onboard orbit determination. The EOS AM Spacecraft is currently baselined with a geocentric attitude, meaning the spacecraft z-body axis will point toward the center of the earth.

**Table 1 : EOS AM Spacecraft Mission Related Requirements (3-sigma)**

Parameter	Requirement
Repeating Ground Track	16 day repeat cycle, 233 orbits per cycle, +/- 20 kilometers at all latitudes
Sun-Synchronous Orbit	10:30 AM descending node, +/- 15 minutes, local mean solar time
Radial Orbit Position Repeatability	+/- 5 kilometers at a given latitude
Earth Pointing Knowledge	+/- 90 arc-seconds, per axis
Earth Pointing Control	+/- 150 arc-seconds, per axis
Earth Pointing Jitter and Stability (Requirements Definition in Progress)	Peak-to-peak, per axis, over time periods from less than 1 second up to 1000 seconds
Navigation Radial Position	+/- 150 meters
Navigation Intrack Position	+/- 150 meters
Navigation Crosstrack Position	+/- 150 meters
Navigation Crosstrack Velocity	+/- 0.160 meters/second
Time Knowledge	+/- 100 microseconds

Table 2 lists the mean orbit elements that satisfy the mission requirements in Table 1. This orbit is very similar to the Landsat-4/5 orbits and may use the same World Reference System (WRS) ground track. The repeating ground track period of 16 days and the sun-synchronous orbit require a mean semimajor axis of 7078 kilometers and a mean inclination of 98.2 degrees. The mean nodal period is 5933 seconds and the mean equatorial altitude is 705 kilometers. The sun-synchronous descending node time is specified with respect to a fictitious mean sun. The local true solar time will actually vary by as much as 16 minutes from the local mean solar time. Radial orbit position repeatability of +/- 5 kilometers requires a frozen orbit with a mean eccentricity of 0.0012 and a mean argument of perigee of 90 degrees.

**Table 2 : EOS AM Spacecraft Mean Orbit Elements**

Parameter	Value
Semimajor Axis	7078 kilometers
Inclination	98.2 degrees
Eccentricity	0.0012
Argument of Perigee	90 degrees
Descending Node	10:30 AM Sun-Synchronous

The EOS AM Spacecraft will use the TDRSS Onboard Navigation System (TONS) as its primary means of navigation. The Global Positioning System (GPS) had previously been considered as the source of measurements for the navigation system. GPS is a satellite based navigation system owned and operated by the Department of Defense (DoD). A TONS / GPS trade study addressed accuracy, power, weight, security, risk, and cost. A TONS implementation would require the addition of TONS software, and would use the S-band transponder and ultrastable oscillator already provided for communications and for ground based TDRSS tracking. A GPS implementation would require additional and redundant flight hardware including antennas, preamps, cabling, and receiver / processors. Performance analyses showed that both TONS and GPS could meet a +/-150 meter navigation requirement under nominal conditions. However, the cost and security concerns of the military version of GPS, and the inability to guarantee the performance of the civilian version of GPS during times of crises, were major factors in the decision to select TONS rather than GPS.

Section 2.0 of this paper describes how navigation errors affect attitude control and geolocation. Section 3.0 provides an overview of TONS and describes the TONS implementation baseline for the EOS AM Spacecraft. Section 4.0 discusses TONS interfaces with the real-time navigation and attitude control system. Example jitter and stability results are also presented in section 4.0. Section 5.0 describes the TONS ground support system and other ground system interfaces. Section 6.0 briefly describes orbit control. Section 7.0 provides a summary and conclusions.

## **2.0 NAVIGATION IMPACT ON ATTITUDE CONTROL AND GEOLOCATION**

The EOS AM Spacecraft navigation system will generate real-time estimates of spacecraft position and velocity. Near real-time position and velocity estimates will be obtained by processing TDRSS Doppler measurement data in an onboard extended Kalman filter. These estimates will then be propagated up to real-time and used to compute the commanded spacecraft body axis inertial attitude as illustrated in Figure 2 and detailed in the Appendix. Examples 1 and 2 in the Appendix show how navigation errors impact the commanded attitude on a per axis basis. TONS and the short term high rate propagator are described later in sections 3.0 and 4.0, respectively.

The EOS AM Spacecraft primary mode attitude determination system will generate real-time estimates of the actual spacecraft body axes inertial attitude. These estimates will be obtained by processing star tracker and rate gyro measurement data in an onboard extended Kalman filter. The attitude control system will compute an attitude error by taking the difference between the commanded attitude and the estimated attitude. The attitude control system will then drive this error toward zero by commanding reaction wheel or thruster torques. Errors in the navigation system will therefore result in errors in the actual spacecraft attitude.

A navigation error will also result in an error in the projection of the spacecraft position on to the surface of the earth, referred to as the subsatellite location knowledge error. The navigation induced subsatellite location knowledge error and the navigation induced attitude error are both illustrated in Figure 3 using the example of a 150 meter in-track position knowledge error. This 150 meter error will result in a 135 meter subsatellite location knowledge error. This 150 meter

error will also result in a 4.4 arc-second attitude error. The 4.4 arc-second attitude error contributes an additional 15 meters to the geolocation knowledge error as shown by example 3 in the Appendix. The total geolocation knowledge error from a 150 meter in-track position knowledge error is therefore 150 meters (135 meters + 15 meters).

A navigation correction will result in spacecraft attitude motion with respect to the desired spacecraft attitude. This attitude motion must be considered when evaluating jitter and stability. The 150 meter in-track position knowledge error is used here again as the example. Assume that the navigation error had grown to 150 meters, then a measurement was processed and the navigation error reduced to 0 meters. Although this situation represents a desirable correction to the navigation estimate, it results in a 4.4 arc-second change in the commanded spacecraft attitude with respect to the desired spacecraft attitude. The actual spacecraft attitude will then change by 4.4 arc-seconds with respect to the desired spacecraft attitude, as the attitude control system tracks this command. The 150 meter correction to the navigation estimate will therefore result in a 150 meter correction to geolocation knowledge, and a 15 meter correction to geolocation pointing.

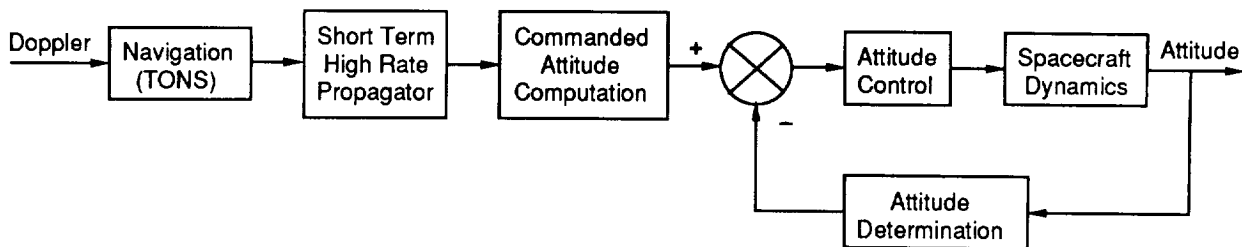

**Figure 2 : TONS / Attitude Control System Interface Block Diagram**

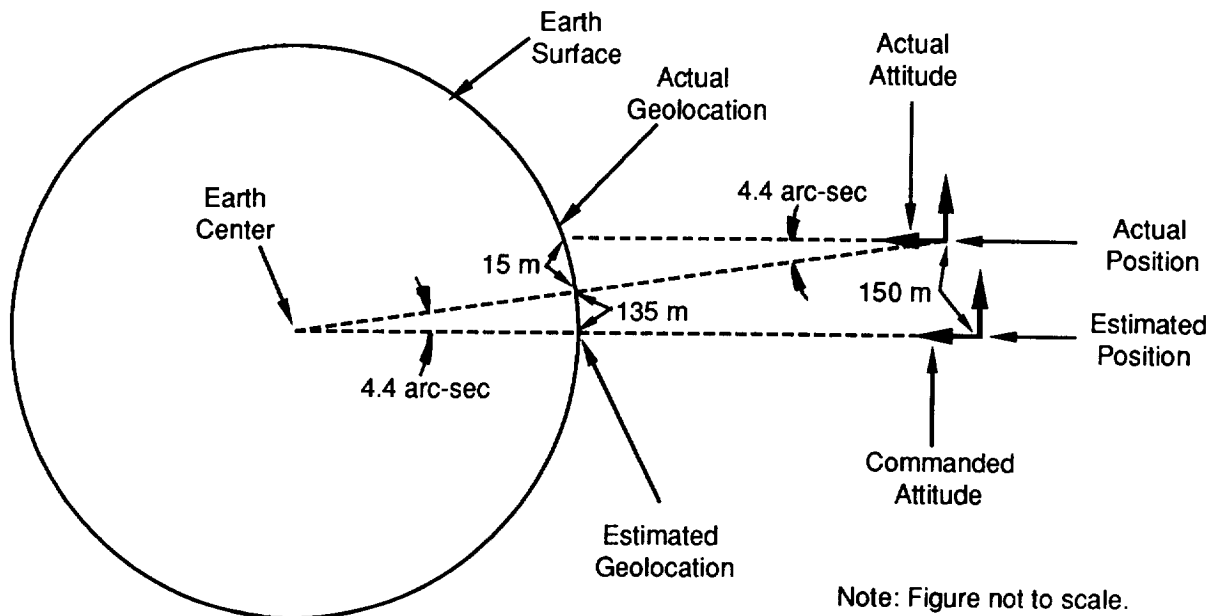

**Figure 3 : Geocentric Earth Based Pointing**

### 3.0 TDRSS ONBOARD NAVIGATION SYSTEM (TONS)

#### TONS Overview

There are two user implementations of TONS, referred to as TONS-I and TONS-II. TDRSS infrastructure currently supports a TONS-I user capability. During scheduled TDRSS communication contacts the TONS-I user extracts, time tags and processes one way forward S-Band (approximately 2106.4 MHz) Doppler measurements. White Sands Ground Terminal Doppler compensation is inhibited so that the user can extract valid Doppler measurements. A TONS-II user would also have access to the planned TDRS-II navigation beacon and would not require scheduled TDRSS services. The TONS-II navigation beacon will include a pseudorange measurement and a navigation message similar to GPS. TONS-II offers the following advantages over TONS-I: reduced TDRSS scheduled resources, near continuous Doppler tracking, more current and accurate TDRS ephemerides, and onboard time determination. The EOS AM Spacecraft is baselined with TONS-I and is expected to have provisions for TONS-II.

A TONS experiment will be performed in conjunction with the Explorer Platform (EP) / Extreme Ultraviolet Explorer (EUVE) mission to flight qualify TONS-I (References 2 and 3). Onboard Doppler extraction, onboard Doppler compensation, and TONS algorithms and software will be proven by this experiment. A GPS receiver / processor will also be flown on EP / EUVE for comparison purposes with TONS. EP / EUVE is currently scheduled for launch in May 1992. TONS data collection and analysis will continue for one year after launch. Lessons learned from the EP / EUVE experiment will be factored into the EOS AM Spacecraft implementation of TONS. Algorithms and software will be optimized for the EOS AM Spacecraft with respect to speed, accuracy and robustness. EOS AM Spacecraft unique features will also be added.

TONS uses an extended Kalman filter to measurement update the state vector estimate and the associated state error covariance matrix. The state vector includes user spacecraft position, velocity, drag coefficient correction, spacecraft ultrastable oscillator frequency bias and drift, and a spacecraft clock time bias. The state error covariance matrix represents the uncertainty in the state vector estimate. The filter computes measurement residuals by taking the difference between actual measurements and estimated measurements. The actual measurement is considered valid if it passes a 3-sigma or 4-sigma measurement residual edit test. The fraction of the measurement residual to be incorporated in the measurement update is a function of the uncertainty in the measurement, and the uncertainty in the current state vector estimate. Spacecraft position and velocity are propagated between measurement updates with a [30 x 30] earth gravity model, drag, solar gravity and lunar gravity. A physically connected state noise model (References 4 and 5) is used to account for uncertainties in the [30 x 30] earth gravity model.

The actual observation from the S-Band transponder is an accumulated Doppler cycle count. A Doppler cycle count difference is computed by taking the difference between two successive accumulated Doppler cycle counts, approximately 10 seconds apart. An average Doppler measurement is computed by dividing the Doppler cycle count difference by the 10 second integration time. The Doppler measurement is modeled in the TONS Kalman filter as a change in range over the 10 second integration time. The measurement model also includes the ultrastable

oscillator frequency bias and drift. TONS requires knowledge of TDRS positions when estimating Doppler measurements. TDRS state vectors will be uplinked daily and propagated in TONS-I with an [8 x 8] earth gravity model, lunar gravity, solar gravity and solar pressure. TDRS positions will be accurate to +/-150 meters (3-sigma) after a one day onboard propagation.

Current and near term TONS algorithm development studies are addressing covariance factorization for numerical stability (Reference 6), addition of a state vector element to model the time correlated measurement noise characteristics of TDRS ephemeris errors, refinements to the earth gravity state noise model, additional measurement residual edit tests, and thrust acceleration modeling during orbit maneuvers. Current and near term error analyses are addressing TDRSS scheduling sensitivities, the effects of a flight processor 48 bit word length, processing requirements for different sections of the EP / EUVE TONS software, ionospheric refraction during periods of high solar activity, and Doppler measurement time tag errors.

### EOS AM Spacecraft Implementation of TONS

The EOS AM Spacecraft will use TONS as the primary means of navigation. TONS performance will vary somewhat as a function of the number, duration, and location of TDRSS scheduled contacts, and the selection of TDRS East or TDRS West. Nominal EOS AM Spacecraft performance analyses have assumed one 20 minute contact every 99 minute orbit. On average, TONS must therefore propagate its state vector estimate and state error covariance matrix for 79 minutes between measurement updates. EOS AM Spacecraft performance assessments for TONS are based on TONS-I (Reference 7). Performance estimates ranged from a best case of 16 meters (1-sigma), to a worst case of 35 meters (1-sigma) for the case of high drag and degraded TDRSS scheduling. The nominal performance estimate is 25 meters (1-sigma).

Communication and navigation requirements will both be factored into the EOS AM Spacecraft TDRSS scheduling process. Multiple shorter duration contacts, e.g., two 10 minute contacts instead of one 20 minute contact, are preferable for navigation because (1) they are easier to optimally schedule than one long contact, (2) they provide the opportunity to observe different parts of the orbit, and (3) they reduce the propagation time between measurement updates. Navigation requirements will be specified by geometric criteria that maximize Doppler observability and minimize ionospheric refraction. Doppler observability is maximized for the radial and in-track directions when the scheduled TDRS is in the EOS AM Spacecraft orbit plane. Ionospheric refraction is minimized by avoiding long, low altitude, signal paths through the earth's atmosphere. In general, geometric requirements for TONS are similar to those for standard ground based orbit determination with TDRSS.

The EOS AM Spacecraft has one 4.5 foot diameter Ku/S-Band high gain antenna, one zenith facing S-Band omni antenna, and one nadir facing S-Band omni antenna. The TONS-I Doppler measurement can be obtained via the high gain antenna with S-Band Multiple Access (SMA) service or S-Band Single Access (SSA) service, or via the zenith S-Band omni antenna with SSA service. Link margin analysis has shown that the TDRS-II navigation beacon could be obtained via the EOS AM Spacecraft high gain antenna.

TONS software will be located in the EOS AM Spacecraft Control Computer (SCC) as shown in the TONS functional interface block diagram in Figure 4. Attitude determination, attitude control, delta-v control, high gain antenna control, solar array drive control, and navigation are all elements of the EOS AM Spacecraft Guidance, Navigation and Control (GN&C) System. The SCC will be a MIL STD 1750A instruction set architecture computer. SCC processing and memory requirements include allocations for TONS Ada flight software, based on EP / EUVE TONS software (Reference 2) with modest growth provisions for EOS AM Spacecraft unique features.

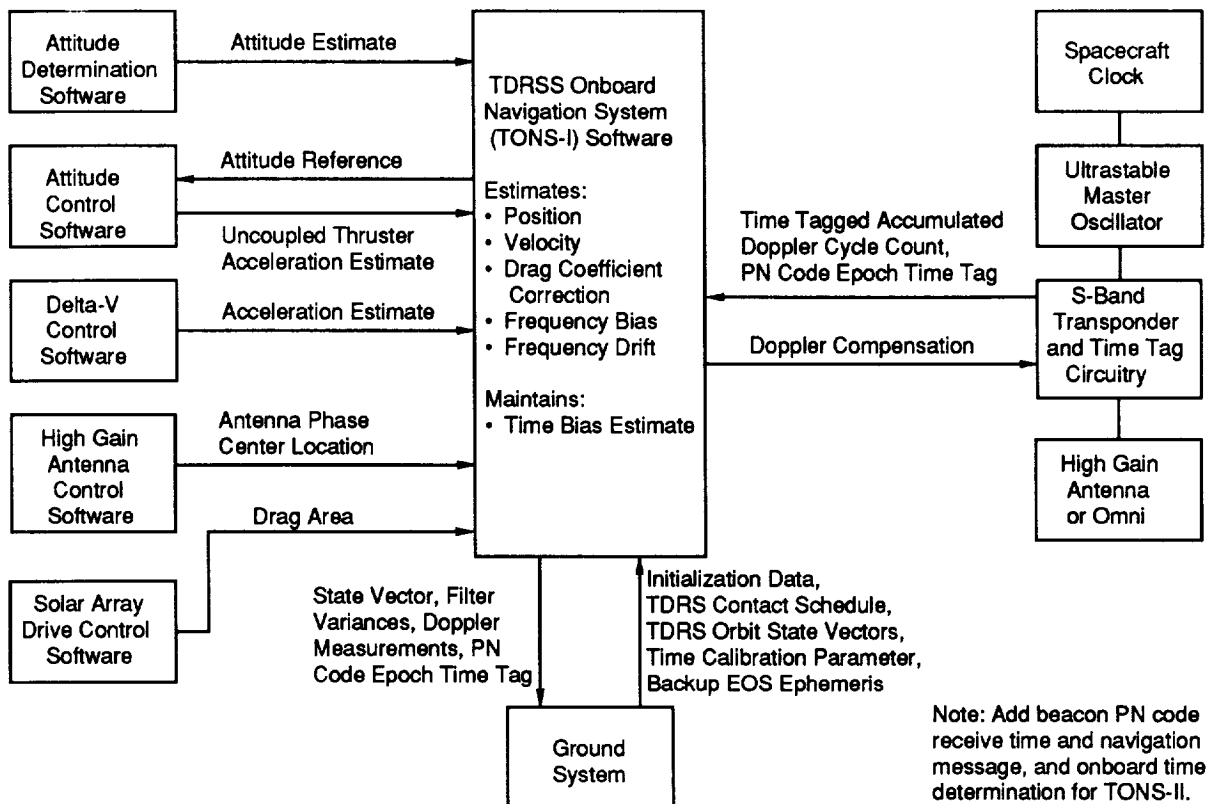

**Figure 4 : TONS / EOS AM Spacecraft Functional Interface Block Diagram**

The EOS AM Spacecraft baseline has a 20 MHz ultrastable master oscillator that provides commonality in reference frequencies for the Command and Data Handling subsystem and the Communication subsystem. The drift in the ultrastable master oscillator will be less than 1.0E-10 parts per day. Short term stability will be approximately 1.0E-12 parts over 10 seconds. The Command and Data Handling subsystem will use the 20 MHz frequency to derive the 1 MHz spacecraft clock. The 20 MHz master oscillator will also be used to derive a 5 MHz frequency for the S-band transponder. The S-Band transponder will be a third generation transponder with a built-in Doppler extraction function. The S-Band transponder will control the Doppler integration interval within an accuracy of +/- 25 nanoseconds. The S-Band transponder will have access to the spacecraft time and frequency bus and will generate time tags for the Doppler measurement.



The EOS AM Spacecraft requires accurate onboard time for (1) time tagging Doppler measurement data for TONS, (2) incorporating uplinked TDRS state vectors and initial EOS state vectors in TONS, (3) time tagging spacecraft position, velocity, attitude, and other data in the spacecraft ancillary telemetry stream, and (4) time tagging instrument science data. The spacecraft time knowledge requirement is +/- 100 microseconds. Actual time knowledge accuracy may vary from +/-5 to +/-30 microseconds, depending upon the accuracy and frequency of ground based spacecraft clock calibrations. TONS-I Doppler only measurements can not estimate the spacecraft clock time bias, but TONS-I frequency bias and drift estimates can be integrated to maintain an onboard software estimate of the spacecraft clock time bias. Preliminary analyses have shown that TONS-I can maintain the time bias estimate within a few microseconds of its uplinked value for days to weeks. Ground based spacecraft clock calibration is described briefly in section 5.0.

In the event of TDRSS contact outages, TONS will continue to propagate an accurate EOS AM Spacecraft state vector and accurate TDRS state vectors. Additionally, a backup onboard ephemeris will be provided for the EOS AM Spacecraft. This ephemeris will be sufficient for S-Band high gain antenna pointing and will also be used periodically in the flight software Fault Detection, Isolation, and Recovery (FDIR) logic for TONS. The TONS position estimate and the backup onboard ephemeris will be differenced, and a flag set if this difference exceeds the accuracy of the backup onboard ephemeris. If this flag is set, the ground system will be notified so that appropriate action can be taken. Various backup ephemeris representations are presently being considered. TONS estimates of the ultrastable master oscillator frequency bias and drift, drag coefficient correction, and time bias could also be compared onboard with uplinked backups.

TONS is not required to meet EOS AM Spacecraft mission requirements during propulsive orbit and attitude maneuvers. Additional TDRSS contacts will be requested during and after these maneuvers for monitoring and tracking. As shown in Figure 4, TONS will have knowledge of thrust accelerations acting on the spacecraft center of mass. TONS will maintain a valid state vector estimate and state error covariance matrix during drag makeup maneuvers. Future analyses will determine if the +/-150 meter navigation requirement can be maintained during drag makeup maneuvers, and if not, the time required to reconverge.

#### **4.0 TONS REAL-TIME INTERFACE**

As discussed in section 2.0 and shown in the Appendix, real-time position and velocity estimates will be used to generate the commanded spacecraft attitude. This section discusses the interface between TONS and the EOS AM Spacecraft real-time navigation and attitude control system. Simulation programs and simulation results are presented as necessary to understand the associated jitter and stability issues. TONS accuracy estimates were presented in section 3.0.

A TONS truth model simulation, a TONS filter model simulation, and an example TONS real-time interface simulation were used to generate the jitter and stability results in this section. These simulations are currently being used for real-time navigation sensitivity studies and for TONS real-time interface algorithm development. The TONS filter model algorithms and simulation results are similar to those in Reference 7.

The TONS truth model simulation used the Artificial Satellite Analysis Program (ASAP), (Reference 8) to generate simulated truth trajectories for the EOS AM Spacecraft, TDRS East, and TDRS West. The EOS AM Spacecraft trajectory was generated with a [36 x 36] GEM-T1 earth gravity model, solar gravity, lunar gravity, solar pressure and drag. Atmospheric density was based on the Jacchia J70 model with a Solar Flux (F10.7) of 230 and a Geomagnetic Activity Index (Ap) of 400. TDRS truth trajectories and TDRS filter trajectories were generated with 150 meter errors similar to those in Reference 7. The TONS "average Doppler" measurement was modeled in the TONS truth model as a "range difference + integrated frequency error range difference equivalent". Units are therefore expressed in meters rather than Hz. The simulated observation was corrupted with timewise uncorrelated Gaussian noise with a 1-sigma value of 0.0141 meters at each sample time. Because the average Doppler measurement (range difference) involves two independent samples, the measurement noise is statistically greater by the square root of two and would be 0.020 meters. Assuming no cycle slips, the measurement noise is actually correlated in a desirable fashion from one measurement to the next. Simulated measurements include the effects of the ultrastable master oscillator frequency bias and drift. The simulated frequency drift was 1.0E-10 parts per day.

The TONS filter model simulation used a ten element state vector (XYZ position, XYZ velocity, drag coefficient correction, oscillator frequency bias, oscillator frequency drift, and a time bias). A fourth order Runge-Kutta integrator was used with a 10 second time step. The TONS state vector estimate and the state error covariance matrix were always propagated to the measurement start time, then to the measurement stop time, but never ahead of the start time in order to prevent backward integration when estimating the measurement. The acceleration model used a [22 x 22] GEM-10B earth gravity model and an exponential atmospheric density model. Position and velocity state noise were modeled in the radial, intrack, and crosstrack directions. In comparison to the simulated truth measurement noise of 0.020 meters, the filter measurement noise value was set high at 0.142 meters to compensate for the unmodeled TDRS ephemeris biases. The oscillator frequency drift and the drag coefficient correction were modeled in the filter as first order Gauss-Markov variables with time constants of 100,000 seconds. The oscillator frequency bias was modeled as the integral of the oscillator frequency drift. The time bias was modeled as the integral of the normalized frequency bias and drift. No effort was made to optimally tune the filter.

The TONS real-time interface simulation used the example timeline and algorithms in Figure 5. Simulated measurements were processed every 10 seconds. A short term high rate propagator took the latest near real-time TONS estimate, measurement updated or not, propagated it forward in time and blended it in with the real-time navigation estimate. The commanded spacecraft attitude was then computed. A third order Taylor series integrator and a J2 earth gravity model were used to propagate the TONS estimate up to real-time. The Taylor series integrator, acceleration and its derivatives were taken from Reference 9. The propagated estimate was blended into the real-time system over a 10 second period in 0.5 second increments. The Taylor series integrator only required one evaluation of acceleration and its derivatives at the start of the 10 second blending interval for all twenty 0.5 second increments. The example interface algorithm in Figure 5 introduced an error less than 0.1 meters in position and less than 0.005 meters/second in velocity. A [4x4] earth gravity model could be used in the acceleration computation to improve accuracy.

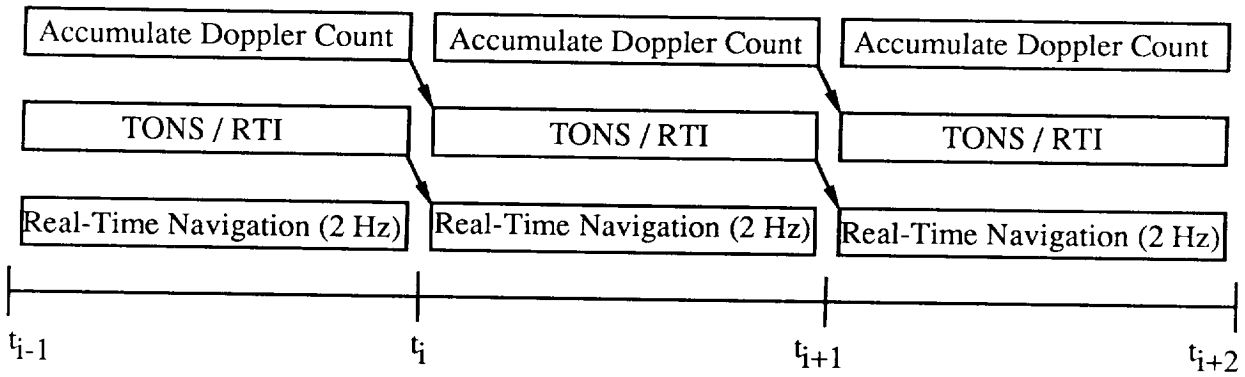

TONS / RTI Software Processing Every 10 Second Cycle ( $t_{i+1} - t_i = 10$  seconds)

- TONS    Receive time tagged accumulated Doppler cycle count  $N_i$ .
- TONS    Compute Doppler cycle count difference:  $\Delta N_i = N_i - N_{i-1}$ . Count  $N_{i-1}$  and time  $t_{i-1}$  known from previous cycle.
- TONS    Propagate TONS state estimate and covariance:  $\hat{x}_{i-1} \rightarrow \hat{x}_i^-$ ;  $P_{i-1} \rightarrow P_i^-$ . TONS state estimate  $\hat{x}_{i-1}$  and covariance  $P_{i-1}$  known from previous cycle.
- TONS    Estimate measurement using TONS state estimates  $\hat{x}_{i-1}$  and  $\hat{x}_i^-$ , then perform edit test.
- TONS    Measurement update TONS state estimate and covariance:  $\hat{x}_i^- \rightarrow \hat{x}_i^+$ ;  $P_i^- \rightarrow P_i^+$ .
- RTI    Propagate TONS state estimate using Taylor series integrator\*:  $\hat{x}_i^+ \rightarrow \tilde{x}_{i+1}'$ .
- RTI    Compute available correction to real-time state estimate:  $\Delta \tilde{x}_{i+1} = [\tilde{x}_{i+1}' - \tilde{x}_{i+1}]$ . Real-time estimate  $\tilde{x}_{i+1}$  is known from previous cycle.
- RTI    Compute real-time state estimates  $\tilde{x}_{i+1+1/20}, \dots, \tilde{x}_{i+2}$  using Taylor series integrator\* with one evaluation of acceleration and its derivatives for time  $t_{i+1}$ :  

$$[\tilde{x}_{i+1} + \Delta \tilde{x}_{i+1} \cdot j/20] \rightarrow \tilde{x}_{i+1+j/20} \quad j = 1, 2, \dots, 20.$$

---

\*Third order Taylor series integrator propagates position ( $\bar{R}$ ) and velocity ( $\dot{\bar{R}}$ ) from any time step (k) to (k+1). Acceleration ( $\ddot{\bar{R}}$ ) and its derivatives include the  $J_2$  earth zonal harmonic.

$$\bar{R}(k+1) = \bar{R}(k) + \dot{\bar{R}}(k) \Delta T + \frac{\ddot{\bar{R}}(k) \Delta T^2}{2} + \frac{\dddot{\bar{R}}(k) \Delta T^3}{6}.$$

$$\dot{\bar{R}}(k+1) = \dot{\bar{R}}(k) + \ddot{\bar{R}}(k) \Delta T + \frac{\dddot{\bar{R}}(k) \Delta T^2}{2} + \frac{\ddddot{\bar{R}}(k) \Delta T^3}{6}.$$

---

**Figure 5 : Example Real-Time Interface (RTI) for TONS**

Simulation results were generated using a two day TDRSS contact schedule that had 20 minutes of geometrically favorable contact with a TDRS every orbit (Reference 7). Simulated errors were computed by comparing simulated filter estimates with simulated truth data. The intrack position error was larger than the radial and crosstrack position errors. A representative one day simulated intrack position error profile is shown in Figure 6. The 1-sigma values from the filter state error covariance matrix were consistent with the simulated errors for all state vector elements.

Peak navigation transients occur during TONS measurement updates as can be seen in Figures 6 and 7 at time [45 hours : 11 minutes = 2711 minutes]. The intrack position error and the associated filter state error covariance matrix had both grown for 79 minutes since the last TONS measurement update at time [43 hours : 52 minutes = 2632 minutes]. At time [45 hours : 11 minutes = 2711 minutes] a measurement was obtained and a 40 meter correction made to the intrack position estimate. Although this 40 meter change is a correction to the TONS intrack position estimate, its effects must be considered in jitter and stability analyses. If incorporated immediately, the 40 meter correction would result in a 1.2 arc-second step change in the commanded pitch attitude. If blended in smoothly over the next 10 seconds as shown in Figure 8, this would result in a 0.12 arc-second per second ramp change in the commanded pitch attitude. Note that the TONS measurement update valid at time [2711 minutes : 00 seconds] was not incorporated into the real-time system until time [2711 minutes : 10.5 seconds].

Figure 8 also shows the approximate attitude control system / spacecraft rigid body response to a navigation transient. This dynamic response is very approximate and is shown here for illustration only. The dynamic response was modeled as a second order system with an undamped natural frequency of 0.14 radians / second and a damping ratio of 0.6. Jitter and stability can be evaluated from the simulated attitude control system response in Figure 8. As an example, the peak-to-peak attitude error change was 0.7 arc-seconds over 10 seconds. A longer blending time will result in a smaller rate of change. Blending the 1.2 arc-second command in over 60 seconds resulted in a peak-to-peak attitude error change of 0.2 arc-seconds over 10 seconds. Navigation transients will be incorporated into the EOS AM Spacecraft attitude control system simulation in the future.

Analysis to date has demonstrated the feasibility of interfacing TONS with the EOS AM Spacecraft real-time navigation / attitude control system. Future studies will address longer blending times and other interface algorithms. For example, the TONS integrator and force model could be used to propagate a state vector ahead of real-time, then real-time data obtained by interpolation. Final algorithm selection will depend upon spacecraft jitter and stability requirements, TONS Doppler measurement processing rate and propagation step size (e.g. every 10 seconds vs. every 60 seconds), and associated accuracy vs. processing trades.

## **5.0 TONS GROUND SYSTEM INTERFACE**

The TONS Ground Support System (TGSS) will be used to perform quality assurance checking of downlinked TONS state vectors, support initial on-orbit filter tuning, evaluate performance, provide diagnostic assistance, and verify flight software updates. The TGSS is currently independent of standard GSFC Flight Dynamics Facility (FDF) operations such as orbit

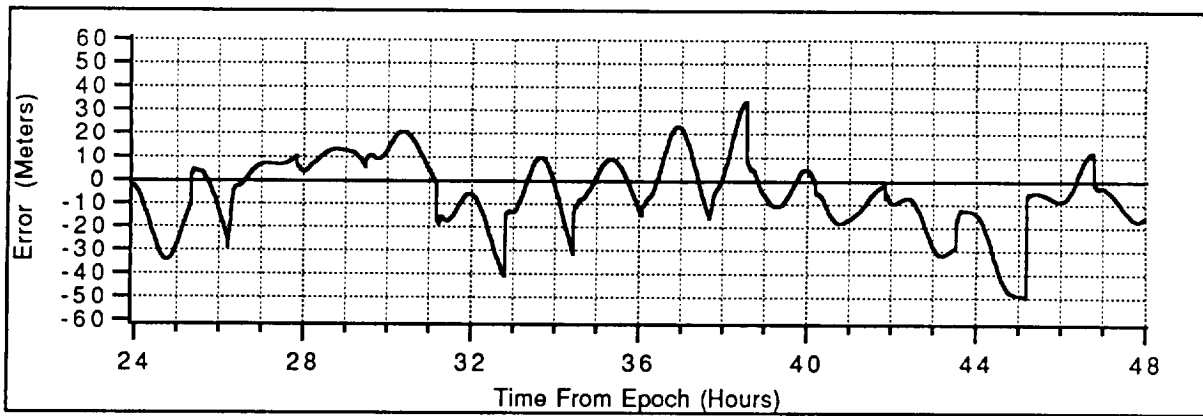

Figure 6 : TONS Intrack Position Error

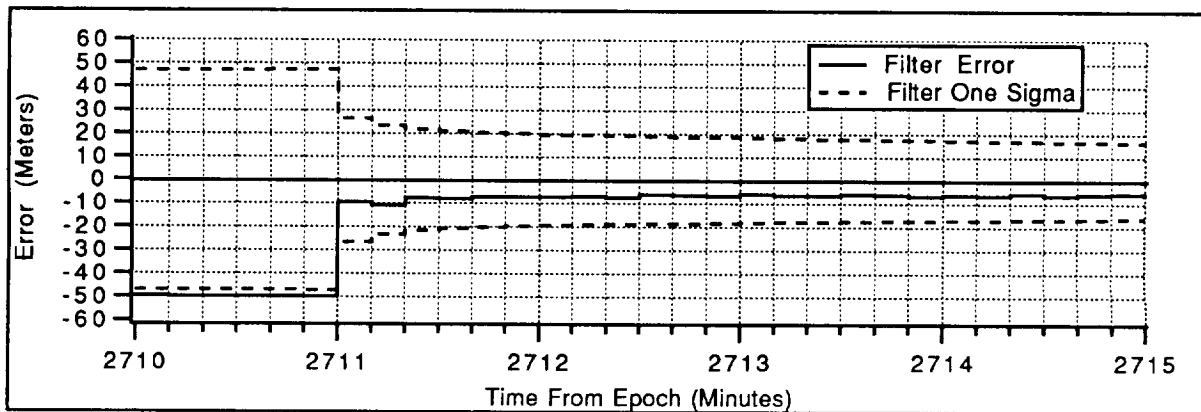

Figure 7 : TONS Intrack Position Error Transient

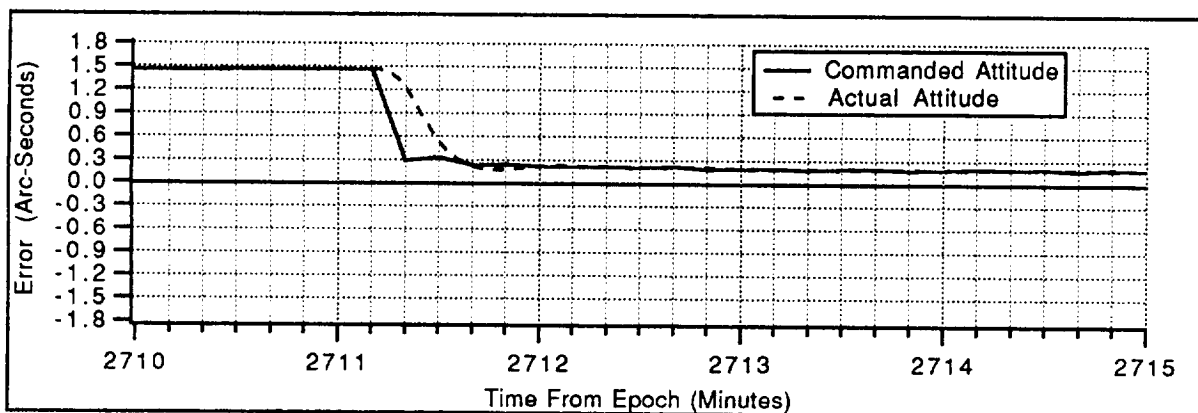

Figure 8 : Approximate Pitch Axis Response

determination and ephemeris generation. The TGSS will be independent of the EOS AM Spacecraft Operations Center which will factor navigation requirements into the TDRSS scheduling process, perform spacecraft clock calibration, and handle normal command and telemetry.

Backup orbit determination and any ephemeris generation functions will be performed by the GSFC FDF. Two way coherent range and Doppler measurements, or one way return noncoherent Doppler measurements will be obtained via TDRSS tracking. Coherent and noncoherent measurements can be obtained simultaneously with TONS onboard Doppler extraction. Ground based measurements will be processed in a batch least squares process to generate an estimate of the spacecraft orbit state vector at a given epoch. This orbit state vector, a table of predicted state vectors, or a Fourier power series fit to a predicted ephemeris will then be uplinked to the EOS AM Spacecraft. This backup ephemeris data will be generated and uplinked as often as necessary depending upon the level of solar activity and drag. Ground based orbit determination results will be used in the TGSS for quality assurance checking of downlinked TONS state vectors.

The EOS AM Spacecraft will use the User Spacecraft Clock Calibration System (USCCS) developed for the Gamma Ray Observatory (GRO). The USCCS is a method designed for calibrating a spacecraft clock using TDRSS pseudo-random noise (PN) ranging epochs. The USCCS is expected to provide time calibration accuracy of approximately +/- 5 microseconds with respect to Universal Time Coordinated (UTC). The USCCS is described in Reference 10. EOS AM Spacecraft clock calibration will be performed by the EOS AM Spacecraft Operations Center in conjunction with the White Sands Ground Terminal. A brief description of the USCCS is given here: (1) The spacecraft S-band transponder extracts and time tags a PN code epoch from the TDRSS forward S-band signal. This time tag is based on the PN code epoch receive time as observed by the spacecraft clock; (2) This time tag is then sent to the ground system in spacecraft telemetry; (3) The ground system estimates the time at which the spacecraft should have received the PN code epoch, then computes the difference between the telemetered time tag and the ground predicted time tag. This difference is the clock calibration parameter; (4) This clock calibration parameter is then uplinked to the spacecraft.

Normal one per orbit navigation telemetry will include time tagged state vector estimates and filter variances, time tagged Doppler measurements, the number of edited Doppler measurements, a flag to indicate if the filter position or velocity variances exceeded pre-specified limits, a flag to indicate if the TONS state estimate exceeded a pre-specified tolerance when compared with the backup onboard ephemeris, and a flag to indicate if other TONS state vector elements exceeded a pre-specified tolerance when compared with onboard backup values. When requested for initial filter tuning, performance evaluation, or diagnostics, telemetry will also include measurement data quality, time tagged filter measurement residuals, and time tagged state error covariance matrices.

Normal one per day navigation commands and data will include TDRS state vectors, a backup EOS ephemeris, a backup for other TONS state vector elements, and a time calibration parameter. As necessary, commands and data will also include an initial state vector estimate and initial state error covariance matrix for TONS, filter tuning parameters for TONS, TDRS contact schedules, flags indicating TDRS orbit adjusts, flags indicating EOS AM Spacecraft orbit and attitude maneuvers, a solar activity parameter, major changes to spacecraft mass, and flight software updates.

Ground based post-processing could be a solution for instruments that might desire non-real-time accuracies significantly better than +/-150 meters. Ground based post-processing has the following advantages in comparison to onboard real-time navigation: (1) Real-time estimates are based on measurement data up to the current time. Post-processed estimates can include additional "future" measurement data when the epoch of interest is centered within the fit interval. In other words, today's estimate of the orbit state vector at yesterday's epoch can be better than yesterday's estimate of the orbit state vector at yesterday's epoch; (2) Ground based computers have more processing and data storage capability than flight computers. This allows for the use of more sophisticated models and algorithms; (3) Ground based post-processing can incorporate additional measurement data types not available to the onboard navigation system, such as two way range data; (4) Ground based post-processing can incorporate today's knowledge of yesterday's solar activity; (5) Ground based post-processing allows for manual inspecting and editing of potentially bad measurements.

## 6.0 ORBIT CONTROL

The GSFC FDF will perform orbit maneuver prediction and orbit maneuver planning. Orbit maneuvers include initial mission orbit acquisition, drag makeup, frozen orbit maintenance, inclination correction, and end-of-life safe re-entry if required. Maneuver command tables will be generated at the GSFC FDF and uplinked via the EOS AM Spacecraft Operations Center. The maneuver planning algorithm considers uncertainties in orbit determination, maneuver execution, and orbit propagation. The maneuver plan will include burn start time, total required  $\Delta V$ , and estimated burn duration. The onboard system will compute the delivered  $\Delta V$  open loop and stop the burn when the commanded  $\Delta V$  has been achieved. The closed loop attitude control system will fire thrusters as necessary to maintain attitude control. TONS state vectors will be used by the GSFC FDF for orbit maintenance maneuvers.

The EOS AM Spacecraft will be launched with an expendable launch vehicle from the Vandenberg Air Force Base in California. The launch vehicle will inject the EOS AM Spacecraft into an orbit with a 300 kilometer perigee altitude and a 705 kilometer apogee altitude. The target apogee altitude may be biased low to account for launch vehicle dispersions, and apogee altitude increases during the mission orbit acquisition sequence. The EOS AM Spacecraft will use its hydrazine based propulsion system to boost up to the mission orbit. The target inclination may also be biased to maximize the time to the first inclination correction maneuver (Reference 11).

Atmospheric drag will cause a decay in semimajor axis. This will result in a decrease in the nodal period and a drift in the ground track. Drag makeup maneuvers will be required to reset the semimajor axis and thus maintain the ground track within the +/- 20 kilometer tolerance. The time between drag makeup maneuvers will vary with the level of solar activity. The time between maneuvers is expected to vary from approximately 7 days to approximately 3 months.

A frozen orbit minimizes altitude variations at any given latitude. The orbit is frozen when secular perturbations due to even zonal harmonics are balanced by long period perturbations due to odd zonal harmonics in the earth's gravity field. This condition exists for the EOS AM Spacecraft orbit

when the mean eccentricity is approximately 0.0012 and the mean argument of perigee is approximately 90 degrees. Once initially acquired, the frozen orbit can be maintained by optimally locating drag makeup burns so as to provide maximum correction to the eccentricity vector. The nominal orbit will have altitudes that range from approximately 705 kilometers at the equator to approximately 732 kilometers near the south pole. Altitude variations due to drag and a non-ideal frozen orbit will result in few kilometers of altitude variation, within the +/-5 kilometer tolerance.

Solar gravity causes a secular decrease in mean inclination for a 10:30 AM descending node orbit. This results in a drift in the descending node time. The time to the first inclination correction maneuver will depend upon the initial inclination and the initial ascending node. If the ideal combination is achieved during launch or during mission orbit acquisition, inclination corrections can be postponed for 5 years (Reference 11). Inclination corrections could typically be expected every few years. Inclination must also be controlled to maintain the ground track at high latitude. Note that inclination corrections require a 90 degree yaw maneuver.

NASA requires that space debris and effects of re-entering space hardware be minimized (Reference 12). EOS is addressing these requirements through detailed break-up / passive re-entry analyses (and design modifications as necessary). This approach meets NASA requirements and requires less propellant and operational complexity than other options (i.e., powered disposal or safe orbit).

## 7.0 SUMMARY AND CONCLUSIONS

1. This paper has summarized the orbit determination and orbit control baseline for the EOS AM Spacecraft. This paper has shown how the TDRSS Onboard Navigation System (TONS) can be integrated into the EOS AM Spacecraft Guidance, Navigation, and Control System. Current and future analyses and design studies have been addressed.
2. Onboard navigation will improve real-time geolocation knowledge and control when compared to previous ephemeris upload methods. Accurate navigation data will be available in the spacecraft telemetry stream and in the direct downlink to user ground stations.
3. Onboard navigation will also reduce the magnitude of geolocation jitter and stability when compared to the magnitude of ephemeris upload transients that typically occur once per day. Blending can be used to further reduce the magnitude of navigation induced transients.

### **Acknowledgements**

The authors wish to acknowledge the following individuals for their contributions to this paper: Jerry Teles and Cheryl Gramling of the NASA Goddard Space Flight Center; Terry Ford and Paul Miller of the General Electric Astro-Space Division. The authors also wish to acknowledge the following individuals for their contributions and discussions on TONS: Anne Long of Computer Sciences Corporation; and Bryant Elrod of Stanford Telecom.



## References

1. Linder, D., *EOS Observatory Pointing and Orbit Requirements*, Prepared for the NASA Goddard Space Flight Center EOS AM Spacecraft Project by the GE Astro-Space Division, EOS-DN-SE&I-020, November 11, 1991.
2. Gramling, Cheryl J., Hart, Roger C., *Onboard Configuration and Operation of the TDRSS Onboard Navigation System (TONS)*, AAS paper 92-010, Presented at 15th Annual AAS Guidance and Control Conference at Keystone Colorado, February 8-12, 1992.
3. Gramling, C. J., et al., *Preliminary Navigation Accuracy Analysis for the TDRSS Onboard Navigation System (TONS) Experiment on EP / EUVE*, NASA GSFC Flight Mechanics / Estimation Theory Symposium, May 21-23, 1991.
4. Wright, J. R., *Sequential Orbit Determination with Auto-Correlated Gravity Modeling Errors*, Journal of Guidance and Control, Vol. 4, No. 3, page 304, 1981, AIAA 80-0239R.
5. Long, A. C., et. al., *TONS Experiment Flight Software Mathematical Specification, Revision 2*, 554-FDD-91/105, Prepared for the NASA Goddard Space Flight Center by Computer Sciences Corporation, June 1991.
6. Bierman, G. J., *Factorization Methods for Discrete Sequential Estimation*, Academic Press, Inc., 1977.
7. Elrod, B., et al., *Earth Observing System (EOS), Analysis of Navigation Performance Using the TDRSS Onboard Navigation System (TONS)*, 544-FDD-91/155, Prepared for the NASA Goddard Space Flight Center by Stanford Telecom, November 1991.
8. Kwok, J. H., *The Artificial Satellite Analysis Program (ASAP)*, Version 2.0, Jet Propulsion Laboratory, April 20, 1987.
9. Lear, William M., *Kalman Filtering Techniques*, JSC-20688, Prepared for the NASA Johnson Space Flight Center, September 1985.
10. *User Spacecraft Clock Calibration System (USCCS) User's Guide*, 531-TR-001, Prepared for the NASA Goddard Space Flight Center by Fredrick Herold and Associates, Inc., October 9, 1991.
11. Folta, D., Kraft, L., NASA Goddard Space Flight Center, *Methodology for the Passive Control of Orbital Inclination and Mean Local Time to Meet Sun-Synchronous Orbit Requirements*, AAS / AIAA Space Flight Mechanics Meeting, Paper # AAS-92-143, Colorado Springs, Colorado, February 24-26, 1992.
12. National Aeronautics and Space Administration (NASA), Office of Safety and Mission Quality, Code Q, *NASA Management Instruction (NMI) : Safety Policy for Space Debris*, Draft, November 11, 1991.

## Appendix : Commanded Body Axes Attitude and Examples

The commanded spacecraft body axes unit vectors ( $\bar{x}_b, \bar{y}_b, \bar{z}_b$ ) are computed using the spacecraft position vector ( $\bar{R}$ ) and velocity vector ( $\dot{\bar{R}}$ ) as shown below. A commanded attitude matrix [A], a direction cosine matrix, can be formed from ( $\bar{x}_b, \bar{y}_b, \bar{z}_b$ ). All vectors are defined in an earth centered inertial coordinate system.

$$\bar{z}_b = -\bar{R}/|\bar{R}| ; \bar{y}_b = -\bar{R} \times \dot{\bar{R}}/|\bar{R} \times \dot{\bar{R}}| ; \bar{x}_b = \bar{y}_b \times \bar{z}_b.$$

( $\bar{x}_b, \bar{y}_b, \bar{z}_b$ ) origin is at the spacecraft center of mass.

$\bar{z}_b$  axis is (+) in the nadir direction. A small rotation about  $\bar{z}_b$  is referred to as yaw.

$\bar{y}_b$  axis is (+) in the direction opposite to the orbital angular momentum vector. A small rotation about  $\bar{y}_b$  is referred to as pitch.

$\bar{x}_b$  axis completes the right handed orthogonal coordinate system, and is not necessarily aligned with the velocity vector direction. A small rotation about  $\bar{x}_b$  is referred to as roll.

### Example 1

A 150 meter intrack position knowledge error results in a commanded pitch attitude error of approximately 4.4 arc-seconds as shown below, using the 7,083,000 meter orbit radius. The same results apply for a crosstrack position error and the resulting commanded roll attitude error.

$$\frac{150 \text{ meters}}{7,083,000 \text{ meters}} \times \frac{(180)(3600) \text{ arc-seconds}}{\pi \text{ radians}} = 4.4 \text{ arc-seconds.}$$

### Example 2

A 0.160 meter / second crosstrack velocity knowledge error results in a commanded yaw attitude error of approximately 4.4 arc-seconds as shown below, using the 7502 meter / second orbit velocity. The crosstrack velocity knowledge error is an error in the knowledge of the velocity vector direction, not an error in the knowledge of the velocity vector magnitude.

$$\frac{0.160 \text{ meters / second}}{7502 \text{ meters / second}} \times \frac{(180)(3600) \text{ arc-seconds}}{\pi \text{ radians}} = 4.4 \text{ arc-seconds.}$$

### Example 3

A 4.4 arc-second pitch or roll attitude error results in a geolocation pointing error of approximately 15 meters as shown below, using the 705,000 meter orbit altitude. A yaw error will rotate an instrument scene, but it will not result in a geolocation pointing error by itself.

$$4.4 \text{ arc-seconds} \times \frac{\pi \text{ radians}}{(180)(3600) \text{ arc-seconds}} \times 705,000 \text{ meters} = 15 \text{ meters.}$$