

4-2075
E7445

NASA Technical Memorandum 106093
AIAA-93-1152

Contributions of Microgravity Test Results to the Design of Spacecraft Fire Safety Systems

Robert Friedman
National Aeronautics and Space Administration
Lewis Research Center
Cleveland, Ohio

and

David L. Urban
Sverdrup Technology, Inc.
Lewis Research Center Group
Brook Park, Ohio

Prepared for the
AHS/ASEE Second Aerospace Design Conference
sponsored by the American Institute of Aeronautics and Astronautics
Irvine, California, February 16-19, 1993



CONTRIBUTIONS OF MICROGRAVITY TEST RESULTS TO THE DESIGN OF SPACECRAFT FIRE-SAFETY SYSTEMS

Robert Friedman
National Aeronautics and Space Administration
Lewis Research Center
Cleveland, Ohio 44135

David L. Urban
Sverdrup Technology, Inc.
Lewis Research Center Group
Brook Park, Ohio 44142

SUMMARY

Experiments conducted in spacecraft and drop towers show that thin-sheet materials have reduced flammability ranges and flame-spread rates under quiescent low-gravity environments (microgravity) compared to normal gravity. Furthermore, low-gravity flames may be suppressed more easily by atmospheric dilution or decreasing atmospheric total pressure than their normal-gravity counterparts. The addition of a ventilating air flow to the low-gravity flame zone, however, can greatly enhance the flammability range and flame spread. These results, along with observations of flame and smoke characteristics useful for microgravity fire-detection "signatures", promise to be of considerable value to spacecraft fire-safety designs. The paper summarizes the fire detection and suppression techniques proposed for the Space Station *Freedom* and discusses both the application of low-gravity combustion knowledge to improve fire protection and the critical needs for further research.

INTRODUCTION

In the confined quarters of orbiting spacecraft, fire is a greatly feared hazard. Thus, fire prevention is strongly emphasized in human-crew space flight, and potentially flammable materials and ignition sources are strictly limited and controlled (ref. 1). Despite these measures, at least three minor fire-threatening incidents involving electrical short circuits or component overheating have been reported on Shuttle missions (ref. 2). Momentary

breakdowns of this nature can be tolerated, however, because, in the enclosed space of the Shuttle, prompt action by the crew can prevent the initiation and spread of fire and confine the damage to the affected component.

Fire protection for the Shuttle includes smoke detectors and extinguishers, whose designs are adapted from those of conventional aircraft and ground fire-protection systems. Shuttle fire-safety requirements thus do not necessarily respond to the special characteristics of low-gravity fires (ref. 3). This recognized need will create opportunities for applications of combustion-science knowledge to spacecraft fire-safety designs and operations, particularly those for future improvements and for the protection of the forthcoming Space Station *Freedom* (ref. 4). The direct application of scientific and engineering data to spacecraft systems is always complicated by severe constraints on mass, volume, and power availability. Nevertheless, these data offer a promise of fire-safety techniques that are more responsive to possible fire incidents, more efficient in operation, and less prone to false alarms.

It is the purpose of this paper, therefore, to present microgravity research data on material flammability, fire characteristics, flame spread, and extinguishment in the space environment. The paper will also review the proposed fire-safety strategies, designs, and operations for the Space Station *Freedom*. The discussion will suggest potential applications of the data and identify unresolved fire-safety design issues and the research required for their resolution.

COMBUSTION IN MICROGRAVITY

Normal-gravity combustion is strongly affected by the buoyant upward flow of hot, low-density combustion products and the entrainment of fresh air it induces. This natural-convective motion enhances mass and heat transfer to replenish the oxygen supply, remove the combustion products, and transport energy into and away from the flame zone. In the low-gravity (microgravity) environment of orbiting spacecraft, natural convection is greatly reduced, if not negligible. The assumption of a non-convective, "zero-gravity" environment is a great convenience to many fundamental combustion theories, because the omission of the gravitational force aids in the study of the effects of certain processes — for example, diffusion, conduction, radiation, and thermocapillarity — that are often overwhelmed by the buoyant flows promoted by normal gravity.

With respect to spacecraft fire safety, it is important to recognize that the near-absence of natural convection will affect not only the flame spread and flammability of fuels in low gravity but also the characteristics of the flame itself. These flame and combustion-product properties determine fire "signatures" for early-warning detection, as well as the response to extinguishment and fire controls.

While analytical models provide valuable insights into the nature of microgravity fires, experimental data that verify the model predictions are essential. The opportunities to conduct microgravity-combustion experiments on space missions have been infrequent. Instead, most low-gravity combustion research must be performed in ground-based, free-fall facilities, such as drop towers or aircraft flying parabolic trajectories (ref. 5).

MICROGRAVITY COMBUSTION-SCIENCE RESEARCH RESULTS

Material Flammability in Low Gravity

Skylab test results. The first quantitative experiments on fires under low gravity and reasonable time durations were the 1974 material-flammability

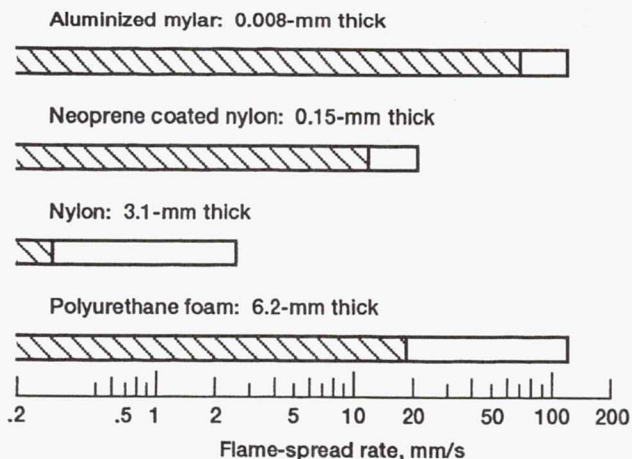

Figure 1.—Flame-spread rates for spacecraft materials, from Skylab zero-gravity flammability tests under an atmosphere of 65-vol. % O_2 in N_2 at 36-kPa total pressure. Shaded bars are microgravity rates; open extensions are corresponding normal-gravity rates.

tests conducted on Skylab (the first U.S. space station), reported by Kimzey (ref. 6). Representative spacecraft materials, including aluminized Mylar, Nylon, neoprene-coated Nylon, polyurethane foam, and paper were ignited in the Skylab atmosphere of 65 vol% O_2 in N_2 at 36-kPa total pressure. The flame-spread rate of the burning materials was calculated by comparison of the flame-front position from successive motion-picture frames. Fig. 1 summarizes the flame-spread results for four of the materials. The normal-gravity reference data were taken under differing flame-spread orientations of upward, downward, and 45° downward. Hence, only qualitative conclusions are possible, but the results with each material indicate that the microgravity flame-spread rates are consistently less than those in normal gravity by factors of the order of 0.15 to 0.60.

In addition to the flame-spread data, the Skylab experiments provided two observations of fire extinguishment that are still of interest for current applications:

- Extinguishment by water is possible, provided the application is controlled and adequate. If insufficient water strikes a burning material, it causes a flare-up that can scatter burning material.

- Extinguishment by vacuum is effective, and the flame is extinguished when the available oxygen decreases sufficiently. A significant side effect is the flame intensification that develops temporarily because of the induced air flow during the initial moments of venting.

Solid Surface Combustion Experiment results.

Recent tests, in a project called the Solid Surface Combustion Experiment (SSCE), have been conducted on selected Shuttle missions, starting with STS-41 in October 1990. The objective of the SSCE is to determine the flame-spread rates, flame characteristics, and heat-transfer rates of sheets of practical materials in a sealed chamber under several low-gravity atmospheric conditions (ref. 7). Fig. 2 shows the trend of microgravity flame-spread rates over thin paper sheets at three total pressures for an atmosphere of 50% O₂ in N₂. The investigators attribute the increase in flame-spread rate with total pressure primarily to an increase in flame radiation to the fuel surface (ref. 8).

Drop-tower experiment results. To date, quantitative data on microgravity flammability from drop-tower tests are available only for thermally thin fuels, that is, those which are essentially isothermal in depth. This is due to the limited microgravity time. It must be recognized, however, that practical spacecraft materials are often thick.

Fig. 3 presents the results of drop-tower studies on microgravity flammability of thin paper wipes (refs. 9 and 10). Two fuel thicknesses were created by single and double layers of the same paper-wipe material. The single-thickness fuel is barely flammable in air, with a limiting oxygen concentration for flame spread (LOC) of 21 vol% O₂; the double-thickness fuel is non-flammable in air, with an LOC of 26% O₂. Corresponding values of the LOC for both thicknesses under normal gravity (downward burning) is at 16.5% O₂.

The data of fig. 3 also indicate that, for initially quiescent environments, normal-gravity flames spread more rapidly than microgravity flames. The induced buoyant flow is sufficient to introduce fresh

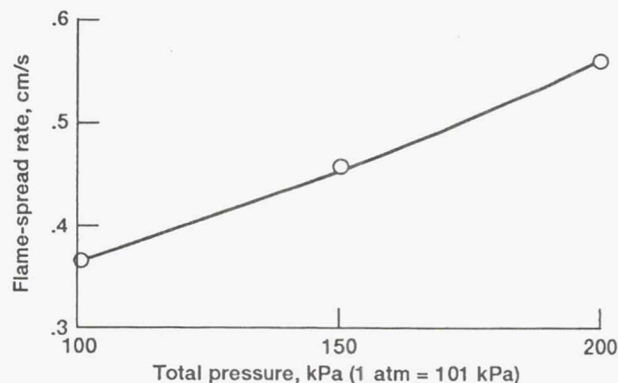

Figure 2.—Effect of total pressure at 50% O₂ on flame-spread rates of thin paper. Data from solid surface combustion experiment (SSCE).

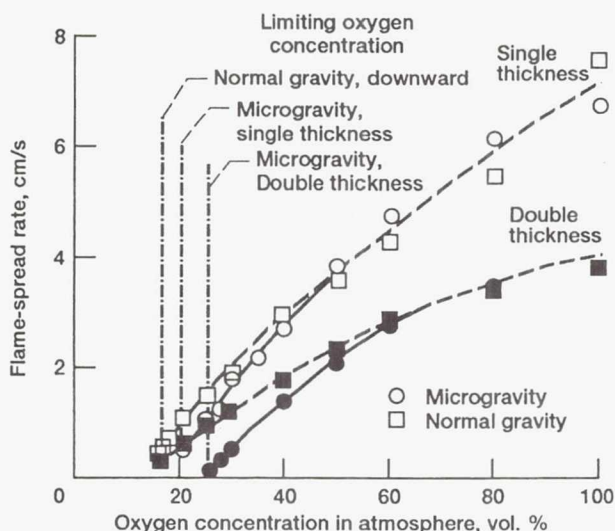

Figure 3.—Flame-spread rates for thin paper fuels (reference single thickness of 0.076 mm) at 101-kPa pressure.

oxidizer to the flame zone, and the controlling (limiting) mechanism for flame spread is gas-phase conduction (ref. 11). Within experimental scatter, however, the spread rate is independent of gravity for oxygen concentrations greater than about 50%. At these levels, the oxygen supply for this fuel is sufficient, and the microgravity flame spread is no longer limited by oxygen transport but is controlled by gas conduction as in normal gravity. The ratio of single- to double-thickness flame-spread rates for thermally thin fuels in normal gravity is typically constant, inversely proportional to the thickness (the lines appear to converge in the linear plot of fig. 3). At low-oxygen-concentration microgravity

conditions, however, the inverse ratio of flame-spread rates with thickness is greater; and this ratio increases as the limiting oxygen concentration is approached.

Velocity and Convective Effects

The material-flammability tests discussed in the previous sections were conducted under quiescent conditions, a state truly obtainable only in negligible gravity, since normal-gravity buoyancy always establishes an appreciable combustion-product flow. The spacecraft environment, however, is likely to induce some forced convection through the usual ventilation and air circulation under almost all operating conditions. Although this air flow is at a very low velocity, it can have a substantial influence on microgravity flammability.

Fig. 4 shows drop-tower experimental data on the effects of forced air flows on microgravity flammability and flame-spread rates. The fuels were single thicknesses of paper wipes. Microgravity tests were conducted with superimposed air flows of the order of 5 to 6 cm/s both opposed to and in-line with (cocurrent) the flame-spread direction (refs. 11 to 13). At low-oxygen-concentration atmospheres, fig. 4 shows that air flows in either direction increase the microgravity flame-spread rates above those for quiescent conditions. Reference curves for downward burning (opposed flow) normal-gravity and quiescent microgravity flame spread are also included in the figure. The flammability range for the microgravity flames with opposed air flow extends to atmospheres with near 15 vol%-O₂ concentrations, well below the LOC of 21% O₂ observed for the quiescent case. The cocurrent-flow flammability range appears to extend to even lower oxygen concentrations (ref. 13). Unstable flame length makes the cocurrent-flow flammability range determined in short-duration tests uncertain, however. Flammability-range data for corresponding conditions of cocurrent flow in normal gravity are not yet available.

Flame Characteristics

The most likely fire situation in spacecraft is that of ignition and combustion of solid surfaces, typified

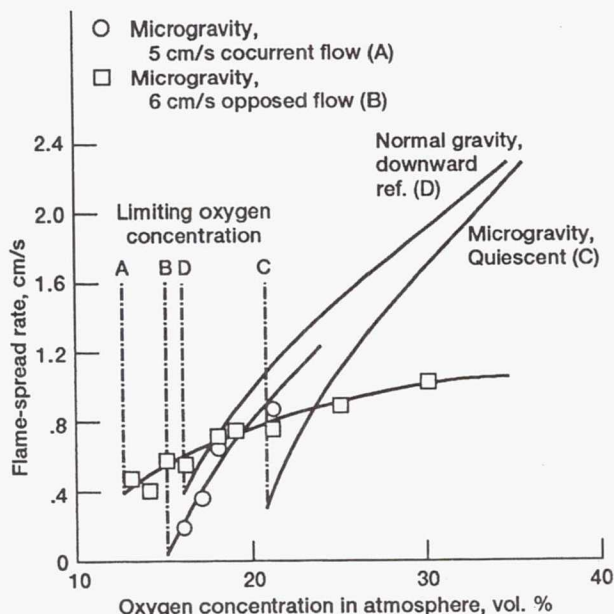

Figure 4.—Flame-spread rates for thin paper under microgravity with air flow cocurrent and opposed to flame spread at 101 kPa pressure.

by wire insulations or thin sheets of paper, cloth, or plastics. Photographs from solid-surface flammability tests have provided evidence that the microgravity flame spreading over a thin surface appears detached from the surface, forming two lobes, one on either side of the pyrolyzing solid (refs. 3 and 11). The flame progresses uniformly without flickering unless the flow is unsteady. With increasing opposed-flow velocities or atmospheric-oxygen concentrations, the microgravity flame decreases in width and moves closer to the fuel surface.

Recognition of the distinctive appearance of the microgravity flame is necessary to establish alarm sensitivities for flame and perhaps smoke detectors in spacecraft.

Fire Suppression

The observations of the effects of extinguishment by water or by venting to vacuum in the Skylab experiment have been cited in an earlier section of this paper. Other tests have simulated suppression conditions on a small scale by drop-tower microgravity-combustion experiments conducted with substituted atmospheric diluents or with decreased atmospheric total pressure.

Atmospheric dilution. Drop-tower combustion tests of thin paper wipes were conducted under atmospheres in which helium, argon, and carbon dioxide were substituted for nitrogen (ref. 14). Since each of these diluents has differing thermal properties of conductivity and heat capacity, they influence the flame-zone temperature and reaction rates in varying ways. Fig. 5 presents data comparing microgravity flammability and flame-spread rates under carbon dioxide-oxygen atmospheres to those under nitrogen-oxygen atmospheres (ref. 15). Results show, first, that the substitution of carbon dioxide as the atmospheric diluent for nitrogen greatly diminishes the flammable range; the limiting oxygen concentration for combustion is increased from 21 vol% to near 35%. Second, the flame-spread rates at low oxygen concentrations are lower for the carbon dioxide-diluent atmosphere than for the nitrogen atmosphere.

In the experiments summarized by fig. 5, each test condition was established by maintaining a constant oxygen quantity equivalent to a 21-kPa partial pressure (the normal sea-level value) and adding diluent to achieve the desired oxygen concentration. The total pressure thus varies from 101 kPa at 21% O₂ to 21 kPa at 100% O₂. The 30%-O₂ condition (72-kPa total pressure) represents the proposed atmosphere for the buildup stages of the Space Station *Freedom*. The data show that, for this atmosphere, the experimental flame-spread rate is greater than that for a 21%-O₂-in-N₂ atmosphere (air) by a factor of about 1.9. On the other hand, under a carbon dioxide-diluent atmosphere, the *Freedom* oxygen concentration is outside of the paper-fuel flammability limit and represents a non-flammable (also non-life-supportive) atmosphere.

The application of the dilution results of fig. 5 to predict spacecraft fire suppression by carbon dioxide flooding must be treated with caution. The tests determined whether flame spread can occur under each prescribed atmosphere, not whether the atmosphere will extinguish an already established fire in air. No tests were conducted with mixed diluents, for example, 50% CO₂ and N₂, to represent realistic suppressant-flooding atmospheres.

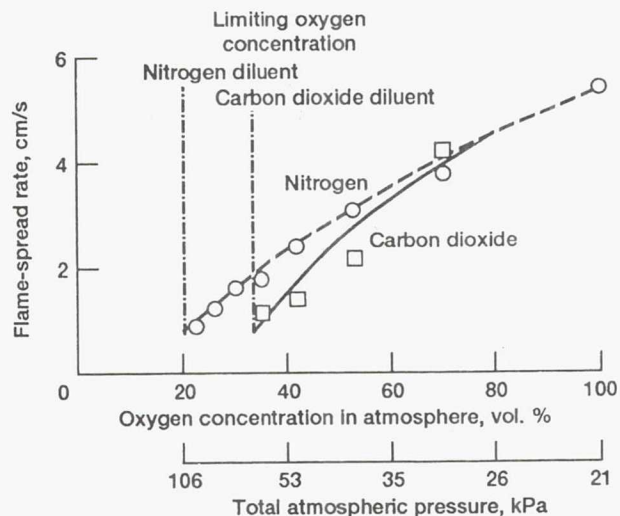

Figure 5.—Effect of carbon dioxide substitution for nitrogen diluent on microgravity flammability of thin paper fuels. Atmospheres have O₂ content fixed at 21 kPa for all cases.

Depressurization. Suggestions are frequently made to investigate atmospheric venting to the vacuum of space to extinguish a difficult fire in spacecraft (ref. 4). Flammability and flame spread depend to a large degree on the atmospheric oxygen concentration, rather than on the oxygen quantity, or partial pressure; and reduction of the total pressure by venting does not alter the composition of the residual atmosphere. Hence, fires can persist as total pressure is lowered, until a condition is reached where the mass transport, through natural convection or other processes, is too low to replenish the flame with oxygen. This may require venting to near-vacuum final conditions.

No data are available on the effect of depressurization on flame suppression in microgravity, other than the single small-scale test in Skylab, cited in an earlier section of this paper (ref. 6). Some related information, however, is available from recent NASA drop-tower tests (J.L. Strom, unpublished data). A series of experiments investigated the flammability of thin cellulose-membrane fuels, under successive atmospheric conditions of decreasing initial total pressure, each identified as a percentage of a reference total pressure, namely, the *Freedom* atmosphere of 30% O₂ at 72-kPa total pressure. Results are summarized in fig. 6. Under normal gravity, the flame-spread rate for successive reduced-total-pressure conditions diminishes

slightly, and a pressure limit of flammability (PLF) is noted at 13% of the original total pressure. For microgravity, flame-spread rate is much more sensitive to the reductions in total pressure, and the PLF is at 78% of the original pressure. The greater sensitivity of the flame to total-pressure reduction is most likely due to the lack of natural-convective mass transport of oxidizer in microgravity.

Although of qualitative significance, the tests cited in fig. 6 do not simulate the suppression of established flames by depressurization, nor do they reproduce the dynamics of air flow induced by depressurization. The observation of venting in Skylab indicated that the depressurization-induced flow causes a flame to flare up, and presumably spread faster, before it succumbs to the reduced total-pressure environment.

FIRE-SAFETY APPLICATIONS TO SPACECRAFT

The Space Station *Freedom*

Fire-safety designs are actively in progress for the protection of the Space Station *Freedom*. *Freedom* will be an aggregation of self-sustaining inhabited volumes and auxiliary platforms placed in a permanent low-earth orbit. The space station provides the opportunity for expansion of life-science studies, microgravity science and technology, earth observations, space-probe launching, and satellite servicing. The initial concern for fire safety is in the protection of the Man-Tended Configuration (MTC), the minimum assembly of components necessary to sustain human activities within the station (ref. 16). *Freedom* will be occupied by the crew only during the Shuttle-tended periods from the MTC until the final configuration of the Permanently Manned Capability. During this period, the module atmosphere will be 30 vol% O₂ in N₂ at a total pressure of 72 kPa to permit egress for space-suited extravehicular activities, without the need for prebreathing to avoid decompression sickness (ref. 17). The enriched-oxygen atmosphere will be retained in the modules during the untended periods between assembly phases.

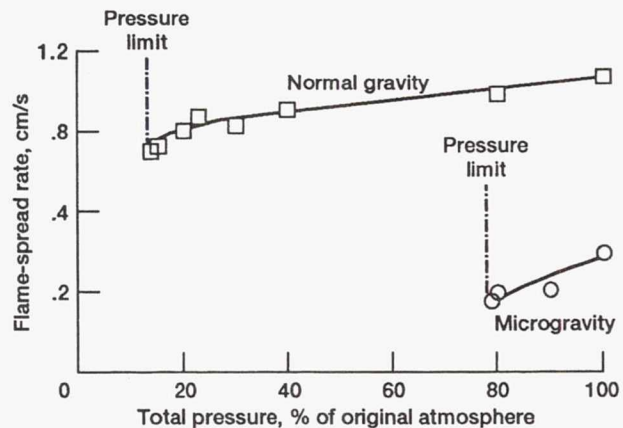

Figure 6.—Effect of total pressure reduction on flammability of thin cellulose fuels. Original atmosphere (100%) is 30-vol. % O₂ in N₂ at 72-kPa total pressure.

The major pressurized, inhabited component at MTC is the laboratory module (fig. 7). In the module, surrounding the central aisle space are racks for payload, control, and storage. The four sectors filling the spaces between the racks, running the length of the module, called standoffs, are used for interconnecting plumbing and wiring. The racks with electrical power (essentially all), standoffs, central core, and the longitudinal end-cone closures will each have dedicated fire detection and suppression provisions.

Fire Prevention

The selection of materials for use in the habitable volumes of spacecraft is based on a prescribed criterion of non-flammability, specifically, flame-spread resistance (ref. 18). Since acceptance testing in low gravity is obviously not feasible, tests conducted in conventional, normal-gravity environments must be interpreted to predict performance in microgravity. For many years, this normal-gravity acceptability had the assurance that flame-spread rates were always lower in microgravity than in normal gravity, an assumption supported by the Skylab material-flammability experiment data (fig. 1).

Because of the known enhancement of microgravity flammability by ventilating flows, the safety factor afforded by normal-gravity testing is now suspect (ref. 1). In addition, there are other microgravity-combustion phenomena that can influence

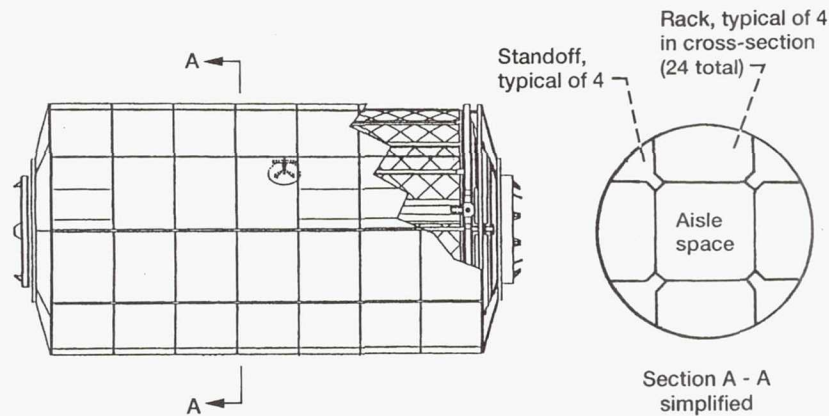

Figure 7.—Freedom laboratory module.

the flammability of materials, including the increased likelihood of smoldering, the long-term persistence of flammable aerosols, and fire spread by radial expulsion of hot particles from melting plastics (refs. 4 and 19). Even flammability rankings of materials determined by comparative testing in normal gravity may be reversed for microgravity conditions (ref. 20). Furthermore, many necessary spacecraft items (including paper, fabrics, and some commercial components) cannot pass any fire-spread acceptance test, and material-usage agreements are necessary to prescribe the quantity limitations and storage conditions of these materials.

Fire Detection

Although fire prevention is emphasized in human-crew spacecraft, one must assume some probability of breakdowns and fire "incidents". Thus, the total program of spacecraft fire protection includes the responsive measures of fire detection, suppression, and post-fire restoration.

Fig. 8 illustrates a mockup of the smoke detector in development for the Space Station *Freedom*. The detector is to be mounted in a duct installed in each protected element, sampling the air flow generated by an exhaust fan. The detector operates on the principle of light scattering by aerosol particles. A beam from a laser source in the upper housing is directed through the light-path chamber and is reflected by mirrors to a photodiode sensor in the

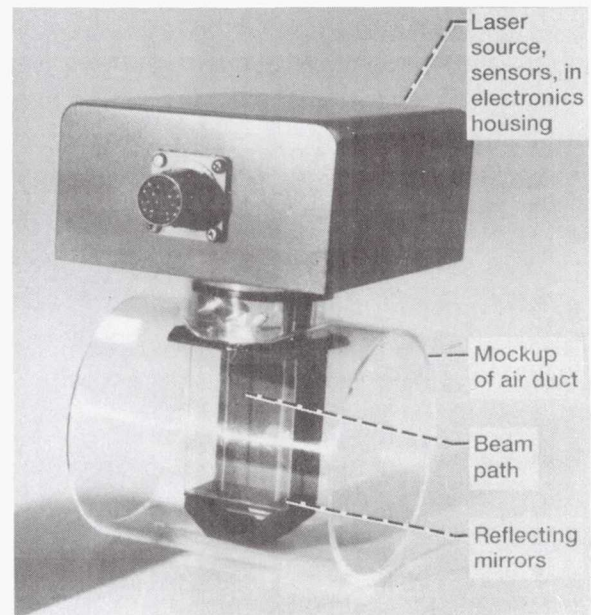

Figure 8.—Model of photoelectric smoke detector for Freedom (Allied Signal Aerospace design).

same upper housing. The sensor is off-axis; hence, it receives radiation and responds with a signal only if the direct beam is scattered by smoke particles in the sampled stream. An additional in-line sensor is available for monitoring a direct beam for built-in testing.

Freedom requirements establish alarm-response levels at minimum values of light obscuration and particle density (ref. 4). The *Freedom* alarm sensitivity is believed to be conservative, representing barely visible smoke from smoldering or fires, although the trade-off of adequate sensitivity to false-alarm rejection is unresolved. These minima

are available only from normal-gravity experience, of course (ref. 21). Preliminary data on smoke emissions in microgravity indicate that soot-aggregate size may be typically larger than those in normal gravity. This is believed due to the increase in residence time through elimination of buoyant flow (D.W. Griffin, Sverdrup Technology, Inc., private communication).

The *Freedom* fire protection will also include flame detectors, located in each end cone. The flame detectors will be radiation sensors, tuned to ultraviolet and visible-light wavelength bands. Minimum alarm-response sensitivities are established, which are conservative values based on airplane standards. No data are available yet on typical microgravity flame emissions and spectral qualities.

Fire Suppression

Fig. 9 is a schematic representation of the proposed carbon dioxide suppression system for *Freedom*. Each of two standoff-mounted tanks contain 2.7 kg of agent; and either tank can release agent in sufficient quantity to flood any protected zone, to a concentration of 50% CO₂, through perforated distributor tubes. During untended periods, the fixed suppression system will release agent either upon a ground signal or a confirmed fire alarm from the space station.

The *Freedom* modules will also have two portable carbon dioxide fire extinguishers, accessible at each end-cone location. The portable fire extinguishers will each have the same agent capacity as the fixed storage tanks. The combination of fixed and portable extinguishing systems provides four independent opportunities for fire fighting during crew-tended periods. Each protected element will have a fire-detection and suppression panel (FDS) (shown in fig. 9), which has a port to accommodate the nozzle of the fire extinguisher for access to the interior of the enclosed volume.

Eventually, microgravity-combustion test results will contribute to the refinement of fire suppression in *Freedom*. There are already at least three concerns that can benefit from further research,

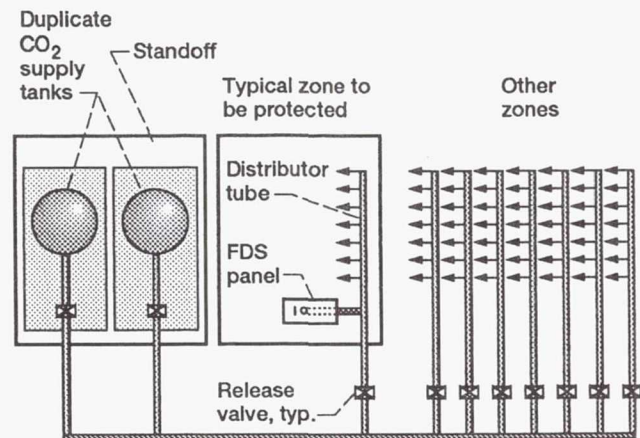

Figure 9.—Schematic of carbon dioxide suppression system proposed for *Freedom*.

namely, extinguishment efficiency in microgravity, toxic leakage of excess agent, and reignition of fires.

First, the response of the microgravity fire to the chemical or physical properties of the agent influences the efficiency and consequent minimum quantity of suppressant, in comparison to that required under normal gravity. A particular problem is in suppressing smoldering, or non-flaming combustion, which is believed to have some probability of occurrence in foam and other construction materials in spacecraft (ref. 1). Smoldering fires can be difficult to detect and difficult to access for suppression, and they threaten to generate toxic and corrosive by-products even if the smoldering fire never progresses into flaming.

A second concern is the toxic properties of the carbon dioxide agent in the module atmosphere. The requirement of flooding to a concentration of 50% CO₂ will overpressurize an affected element, requiring venting and some unavoidable leakage into the module that can easily exceed the allowable concentration limits of the atmosphere. Nontoxic alternatives, such as nitrogen or water, have been suggested; but all agents have recognized drawbacks in their practical application to spacecraft (ref. 4). The difficulty of dispensing liquid water in microgravity was one observation of the Skylab experiments (noted in an earlier section of this paper).

A third concern is the possibility of reignition after apparent extinguishment. Since heat transfer by natural convection in low gravity is negligible, fire-heated surfaces cool slowly. Premature cessation of agent application or attempts to cool with forced air flow may instead provide fresh oxidizer to the fire-heated surface to re-establish the fire, particularly in untended periods when the affected zone cannot be observed.

Post-Fire Restoration

In contrast to the Shuttle, where cleanup after minor incidents or fires can be accomplished on the ground after a mission is terminated, post-fire cleanup and restoration activities for *Freedom* must be conducted in orbit. There is not only the immediate problem of removal of atmospheric products and repair of component damage but also the long-term problem of recognizing and alleviating toxicity and corrosion from contamination that may be evident only after periods of days or longer after a fire.

For atmospheric restoration after any but minor fire situations, the removal of smoke aerosols, toxic combustion products, and excess carbon dioxide agent is far beyond the filtering and revitalization capacity of the *Freedom* Environmental Control and Life Support System. At least two cleanup approaches are under consideration. One concept is a permanent self-contained unit with filtering and adsorption beds maintained on-board and sized for emergency use after a fire (ref. 22). Mass, volume, and power limitations hamper the development of this system. A much simpler concept is that of venting the affected element to the vacuum of space using the existing suppressant-delivery system with its relief valve and vent. Engineering problems to be addressed in this design concept are those of dealing with orifice clogging from soot and smoke particles and release- or vent-valve damage from hot gas flow. Controlled-flow venting of individual elements for atmospheric cleanup is not to be confused with the rapid, large-scale module venting suggested for emergency fire suppression. The latter procedure has the undesirable feature, already noted in this paper, of temporary flame enhancement by induced flow.

Long-term corrosion of electronic and other components from post-fire residues is also recognized as a problem, but preventive or restorative approaches are not yet developed.

CRITICAL ISSUES FOR SPACECRAFT FIRE PROTECTION

Ideally, spacecraft fire protection must not compromise safety nor, at the same time, impede the full utilization of *Freedom*. Fire-protection designs, furthermore, are limited by space station requirements that control component mass, volume, and power and maintain strict quality-control standards. Nevertheless, the application of fundamental combustion-science knowledge will promote improved fire-safety efficiency and assurance. There are several design and operational issues in spacecraft fire safety can benefit from these research applications in the near future.

- The increased flammability of materials under the 30 vol%-O₂, 72-kPa total-pressure atmosphere for the assembly stages of the Space Station *Freedom* must be recognized. The reduced total pressure may decrease the flame-spread rate, but the higher oxygen concentration increases the rate to a much higher degree. Data from small-scale microgravity experiments indicate that flame-spread rates in *Freedom* atmospheres are greater by about a factor of two compared to those under air. Obviously, for the *Freedom* atmosphere, the number of acceptable materials will decrease; and the number of necessary waived materials will increase.

- Data from small-scale microgravity experiments indicate that flammability criteria must recognize, in addition, the enhanced flammability of representative materials under microgravity with imposed ventilation flows. Eventually, some means must be devised to interpret the extensive databank of acceptable materials established by normal-gravity testing in terms of flammability in microgravity with representative ventilation.

- Signature and alarm levels appropriate to the recognition of microgravity fire incidents must be

established, with a balance of high sensitivity to false-alarm rejection. Appropriate small-scale experiments on flame and emission characteristics are being initiated, but no quantitative data applicable to microgravity fire signatures are yet available. Qualitative observations indicate that these signatures can be considerably different from their normal-gravity counterparts.

- Minimum flooding concentrations, maximum release times, minimum suppressant-retention times, and failure-tolerant redundancies for fire-suppression systems must be determined. Data from small-scale microgravity experiments indicate that flame suppression may be more effective in low gravity, suggesting design economies. Confidence in applying this information awaits full-scale testing at representative spacecraft conditions, however.

CONCLUDING REMARKS

Experience has demonstrated that present fire protection of Shuttle is adequate, but future missions, particularly those of the Space Station *Freedom*, demand improved technologies. Fire-safety concepts can benefit greatly from the growing knowledge of low-gravity (microgravity) combustion science. Applications of this knowledge promise to help meet goals of minimum risk of fire loss, minimum interference with spacecraft operations, and minimum mass and power consumption. Examples of these applications include 1) material selection determined by predicted flammability assessments for ventilated microgravity environments, 2) single-failure-tolerant fire-detection systems with appropriate set points based on demonstrated characteristics of microgravity fires and emissions, 3) extinguishing agents selected for maximum effectiveness based on applications of microgravity suppression data, and 4) emergency, high-capacity environmental controls for post-fire cleanup and rehabilitation in orbit.

REFERENCES

1. Rodney, G.A.: Critical Safety Assurance Factors for Manned Spacecraft — A Fire Safety Perspective. IAF Paper 90-555, Nov. 1989.
2. Limero, T.; James, J.; Cromer, R.; and Beck, S.: A Combustion Products Analyzer for Contingency Use During Thermodegradation Events in Spacecraft. SAE Tech. Paper 911479, July 1991.
3. Friedman, R.; and Olson, S.L.: Fire Safety Applications for Spacecraft, in *Aircraft Fire Safety*, AGARD Conf. Publ. No. 467, Oct. 1989, pp. 15-1 to 15-15.
4. Friedman, R.; Sacksteder, K.R.; and Urban, D.: Risks, Designs, and Research for Fire Safety in Spacecraft. NASA TM 105317, Nov. 1991.
5. Lekan, J.: Microgravity Research in NASA Ground Based Facilities. AIAA Paper 89-0236, Jan. 1989.
6. Kimzey, J.H.: Skylab Experiment M479 Zero Gravity Flammability, in *Skylab Results*, Proc. Third Space Processing Symp., Vol. 1, NASA MSFC M-74-5 (NASA TM X-80252), Jan. 1974, pp. 115-130.
7. Vento, D.; Zavesky, R.; Sacksteder, K.; and Altenkirch, R.: The Solid Surface Combustion Space Shuttle Experiment Hardware Description and Ground-Based Test Results. AIAA Paper 89-0503, Jan. 1989.
8. Bullard, D.B.; Tang, L.; Altenkirch, R.A.; and Bhattacharjee, S.: Unsteady Flame Spread Over Solid Fuels in Microgravity. Paper presented at Comm. on Space Res., World Space Congr., Washington, Sept. 1992.
9. Olson, S.L.: The Effect of Microgravity on Flame Spread Over a Thin Fuel. NASA TM 100195, Dec. 1987.
10. Olson, S.L.; Ferkul, P.V.; and T'ien, J.S.: Near-Limit Flame Spread Over a Thin Solid Fuel in Microgravity. *Twenty-Second Symposium (International) on Combustion*, The Combustion Inst., Pittsburgh, 1989, pp. 1213-1222.

11. Olson, S.L.: Mechanisms of Microgravity Flame Spread Over a Thin Solid Fuel: Oxygen and Opposed Flow Effects. *Comb. Sci. and Tech.*, vol. 76, 1991, pp. 233-249.

12. Ferkul, P.V.: An Experimental Study of Opposed Flow Diffusion Flame Extinction Over a Thin Fuel in Microgravity. NASA CR 182185, Feb. 1989.

13. Grayson, G.; Sacksteder, K.R.; and T'ien, J.S.: An Experimental Study of Low Speed Concurrent-Flow Flame Spread over a Thin Fuel. Paper presented at the Combustion Inst., Central States Sec., Spring Tech. Mtg., April 1991.

14. Olson, S.L.; Stouffer, S.C.; and Grady, T.: Diluent Effects on Quiescent Microgravity Flame Spread over a Thin Solid Fuel. Paper presented at the Combustion Inst., Eastern States Sec., Fall Tech. Mtg., Oct.-Nov. 1989.

15. Friedman, R.; and Dietrich, D.L.: Fire Suppression in Human-Crew Spacecraft. *Jour. Applied Fire Science*, vol. 1, no. 3, 1990-1991, pp. 243-258.

16. Sendral, E.D.E.: Overview and Status of Space Station *Freedom* Modules. AIAA Paper 92-1307, March 1992.

17. McCarthy, K.B.; and Green, J.A.: The Effect of Reduced Cabin Pressure on the Crew and Life Support System. SAE Tech. Paper 911331, July 1991.

18. NASA Office of Safety and Mission Quality: Flammability, Odor, Offgassing, and Compatibility Requirements and Test Procedures for Materials in Environments That Support Combustion. NASA NHB 8060.1C, April 1991.

19. Olson, S.L.; and Sotos, R.G.: Combustion of Velcro in Low Gravity. NASA TM 88970, March 1987.

20. Tien, J.S.: The Possibility of Reversal of Material Flammability Ranking from Normal Gravity to Microgravity. *Comb. and Flame*, vol. 80, 1990, pp. 355-357.

21. Thomas, E.C.: Microgravity Fire Detection Problems — Fact of Fiction? SAE Tech. Paper 901215, July 1990.

22. Sribnik, F.; Birbara, P.J.; Faszczka, J.J.; and Nalette, T.A.: Smoke and Contaminant Removal System for Space Station. SAE Tech. Paper 901391, July 1990.

REPORT DOCUMENTATION PAGE

Form Approved
OMB No. 0704-0188

Public reporting burden for this collection of information is estimated to average 1 hour per response, including the time for reviewing instructions, searching existing data sources, gathering and maintaining the data needed, and completing and reviewing the collection of information. Send comments regarding this burden estimate or any other aspect of this collection of information, including suggestions for reducing this burden, to Washington Headquarters Services, Directorate for Information Operations and Reports, 1215 Jefferson Davis Highway, Suite 1204, Arlington, VA 22202-4302, and to the Office of Management and Budget, Paperwork Reduction Project (0704-0188), Washington, DC 20503.

1. AGENCY USE ONLY (Leave blank)	2. REPORT DATE March 1993	3. REPORT TYPE AND DATES COVERED Technical Memorandum	
4. TITLE AND SUBTITLE Contributions of Microgravity Test Results to the Design of Spacecraft Fire Safety Systems		5. FUNDING NUMBERS WU-323-53-62	
6. AUTHOR(S) Robert Friedman and David L. Urban		7. PERFORMING ORGANIZATION NAME(S) AND ADDRESS(ES) National Aeronautics and Space Administration Lewis Research Center Cleveland, Ohio 44135-3191	
8. PERFORMING ORGANIZATION REPORT NUMBER E-7445		9. SPONSORING/MONITORING AGENCY NAMES(S) AND ADDRESS(ES) National Aeronautics and Space Administration Washington, D.C. 20546-0001	
10. SPONSORING/MONITORING AGENCY REPORT NUMBER NASA TM-106093 AIAA-93-1152		11. SUPPLEMENTARY NOTES Prepared for the AHS/ASEE Second Aerospace Design Conference sponsored by the American Institute of Aeronautics and Astronautics, Irvine, California, February 16 - 19, 1993. Robert Friedman, NASA Lewis Research Center and David L. Urban, Sverdrup Technology, Inc., Lewis Research Center Group, 2001 Aerospace Parkway, Brook Park, Ohio 44142. Responsible person, Robert Friedman, (216) 433-5697.	
12a. DISTRIBUTION/AVAILABILITY STATEMENT Unclassified - Unlimited Subject Category 18		12b. DISTRIBUTION CODE	
13. ABSTRACT (Maximum 200 words) Experiments conducted in spacecraft and drop towers show that thin-sheet materials have reduced flammability ranges and flame-spread rates under quiescent low-gravity environments (microgravity) compared to normal gravity. Furthermore, low-gravity flames may be suppressed more easily by atmospheric dilution or decreasing atmospheric total pressure than their normal-gravity counterparts. The addition of a ventilating air flow to the low-gravity flame zone, however, can greatly enhance the flammability range and flame spread. These results, along with observations of flame and smoke characteristics useful for microgravity fire-detection "signatures", promise to be of considerable value to spacecraft fire-safety designs. The paper summarizes the fire detection and suppression techniques proposed for the Space Station Freedom and discusses both the application of low-gravity combustion knowledge to improve fire protection and the critical needs for further research.			
14. SUBJECT TERMS Aerospace safety; Combustion products; Extinguishing; Flammability; Fires; Reduced gravity; Smoke detectors; Space stations; Weightlessness			15. NUMBER OF PAGES 12
17. SECURITY CLASSIFICATION OF REPORT Unclassified			16. PRICE CODE A03
18. SECURITY CLASSIFICATION OF THIS PAGE Unclassified	19. SECURITY CLASSIFICATION OF ABSTRACT Unclassified	20. LIMITATION OF ABSTRACT	

National Aeronautics and
Space Administration

Lewis Research Center
Cleveland, Ohio 44135

Official Business
Penalty for Private Use \$300

FOURTH CLASS MAIL



ADDRESS CORRECTION REQUESTED

NASA
